



# element<sup>®</sup>

**GCE Group**  
**Zen-O with Clarity**

**SAR Evaluation Report # GCEG0001.1 Rev. 1**

**Evaluated to the following SAR specification:**

**FCC 2.1093:2018**



NVLAP Lab Code: 200630-0

*This report must not be used to claim product certification, approval, or endorsement by NVLAP, NIST, or any agency of the federal government of the United States of America. This Report shall not be reproduced, except in full without written approval of the laboratory.*

# CERTIFICATE OF TEST



**Last Date of Test: 2018/02/21**  
**GCE Group**  
**Model: Zen-O with Clarity**

## Applicable Standard

Test Description	Specification	Test Method	Pass/Fail
SAR Evaluation	FCC 2.1093:2018	IEEE Std 1528:2013, FCC KDB 447498 D01 v06 FCC KDB 941225 D01 v03r01 FCC KDB 941225 D05 v02r05 FCC KDB 616217 D04 v01r02 FCC KDB 865664 D01 v01r04 FCC KDB 865664 D02 v01r02	Pass

## Highest SAR Values:

Frequency Bands (GHz)	Body (W/kg)	Limit (W/kg)	Exposure Environment
	1g	1g	
GSM	1.50	1.6	General Population
PCS	1.41		

## Deviations From Test Standards

None

## Approved By:

*Don Facteau, Systems Architect*

# REVISION HISTORY



Revision Number	Description	Date	Page Number
01	Removed FCC 15.247:2018 from report and updated methods	2018/05/16	1, 2, 14-17, 19, 29, 30, 34
01	Deleted scaling factor formula from page	2018/05/16	8
01	More information provided about modification.	2018/05/16	10
01	Updated header value from mW/g to W/kg	2018/05/16	31, 35
01	Updated date format to ISO international date format of yyyy-mm-dd	2018/05/16	Various

# ACCREDITATIONS AND AUTHORIZATIONS



---

## United States

---

**FCC** - Designated by the FCC as a Telecommunications Certification Body (TCB). Certification chambers, Open Area Test Sites, and conducted measurement facilities are listed with the FCC.

**A2LA** - Accredited by A2LA to ISO / IEC 17065 as a product certifier. This allows Element to certify transmitters to FCC and IC specifications.

**NVLAP** - Each laboratory is accredited by NVLAP to ISO 17025

---

## Canada

---

**ISED** - Recognized by Innovation, Science and Economic Development Canada as a Certification Body (CB). Certification chambers and Open Area Test Sites are filed with ISED.

---

## European Union

---

**European Commission** – Within Element, we have a EU Notified Body validated for the EMCD and RED Directives.

---

## Australia/New Zealand

---

**ACMA** - Recognized by ACMA as a CAB for the acceptance of test data.

---

## Korea

---

**MSIT / RRA** - Recognized by KCC's RRA as a CAB for the acceptance of test data.

---

## Japan

---

**VCCI** - Associate Member of the VCCI. Conducted and radiated measurement facilities are registered.

---

## Taiwan

---

**BSMI** – Recognized by BSMI as a CAB for the acceptance of test data.

**NCC** - Recognized by NCC as a CAB for the acceptance of test data.

---

## Singapore

---

**IDA** – Recognized by IDA as a CAB for the acceptance of test data.

---

## Israel

---

**MOC** – Recognized by MOC as a CAB for the acceptance of test data.

---

## Hong Kong

---

**OFCA** – Recognized by OFCA as a CAB for the acceptance of test data.

---

## Vietnam

---

**MIC** – Recognized by MIC as a CAB for the acceptance of test data.

---

## SCOPE

For details on the Scopes of our Accreditations, please visit:

<http://portlandcustomer.element.com/ts/scope/scope.htm>

<http://gsi.nist.gov/global/docs/cabs/designations.html>

# FACILITIES



<b>California</b> Labs OC01-17 41 Tesla Irvine, CA 92618 (949) 861-8918	<b>Minnesota</b> Labs MN01-10 9349 W Broadway Ave. Brooklyn Park, MN 55445 (612)-638-5136	<b>New York</b> Labs NY01-04 4939 Jordan Rd. Elbridge, NY 13060 (315) 554-8214	<b>Oregon</b> Labs EV01-12 6775 NE Evergreen Pkwy #400 Hillsboro, OR 97124 (503) 844-4066	<b>Texas</b> Labs TX01-09 3801 E Plano Pkwy Plano, TX 75074 (469) 304-5255	<b>Washington</b> Labs NC01-05 19201 120 <sup>th</sup> Ave NE Bothell, WA 98011 (425)984-6600
<b>NVLAP</b>					
NVLAP Lab Code: 200676-0	NVLAP Lab Code: 200881-0	NVLAP Lab Code: 200761-0	NVLAP Lab Code: 200630-0	NVLAP Lab Code:201049-0	NVLAP Lab Code: 200629-0
<b>Innovation, Science and Economic Development Canada</b>					
2834B-1, 2834B-3	2834E-1, 2834E-3	N/A	2834D-1, 2834D-2	2834G-1	2834F-1
<b>BSMI</b>					
SL2-IN-E-1154R	SL2-IN-E-1152R	N/A	SL2-IN-E-1017	SL2-IN-E-1158R	SL2-IN-E-1153R
<b>VCCI</b>					
A-0029	A-0109	N/A	A-0108	A-0201	A-0110
<b>Recognized Phase I CAB for ACMA, BSMI, IDA, KCC/RRA, MIC, MOC, NCC, OFCA</b>					
US0158	US0175	N/A	US0017	US0191	US0157

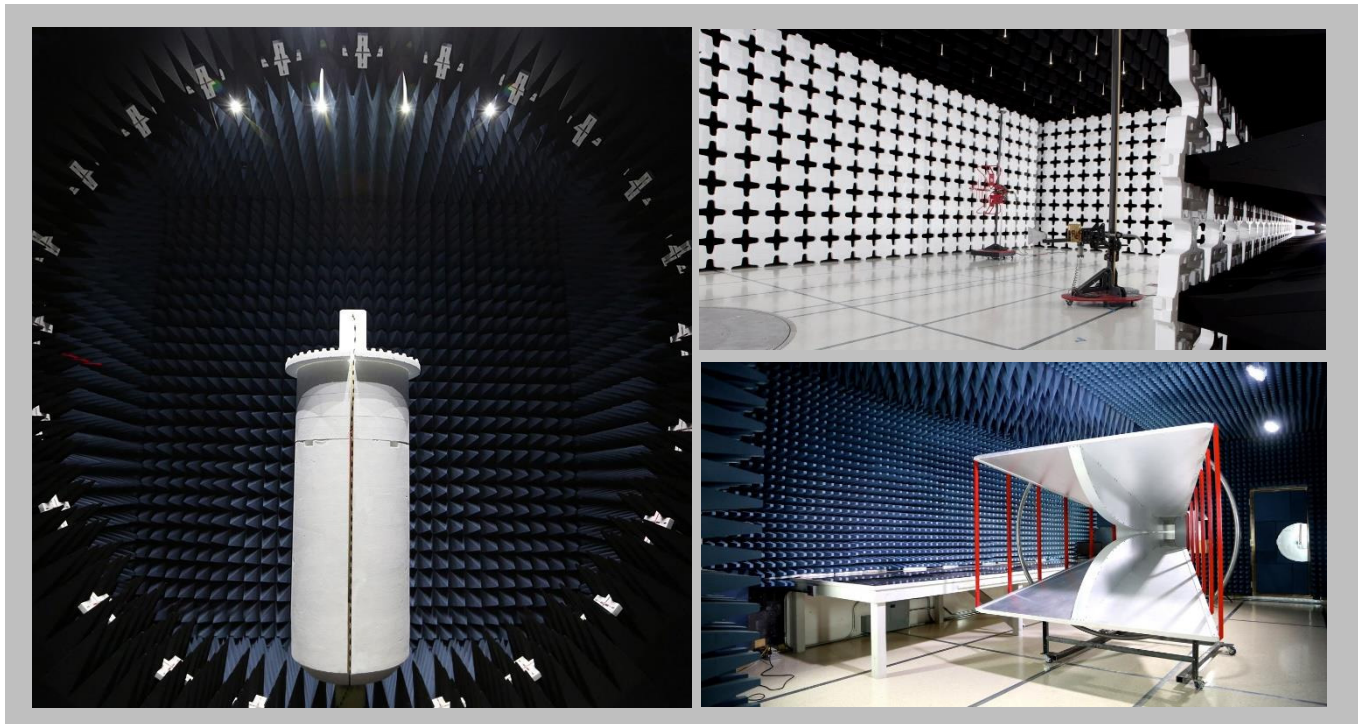



# PRODUCT DESCRIPTION

## Client and Equipment Under Test (EUT) Information

<b>Company Name:</b>	GCE Group
<b>Address:</b>	100 Empress Park Penny Lane
<b>City, State, Zip:</b>	Haydock, WA11 9DB
<b>Test Requested By:</b>	Will Turner
<b>Model:</b>	Zen-O with Clarity
<b>First Date of Test:</b>	2018/02/07
<b>Last Date of Test:</b>	2018/02/21
<b>Receipt Date of Samples:</b>	2018/01/26
<b>Equipment Design Stage:</b>	Production
<b>Equipment Condition:</b>	No Damage
<b>Purchase Authorization:</b>	Verified

## Information Provided by the Party Requesting the Test

### Functional Description of the EUT:

Zen-O with Clarity portable oxygen concentrator is designed to enable patients with respiratory disorders such as chronic obstructive pulmonary disease (COPD), to better manage their oxygen therapy within and outside their homes. The device is wearable, powered by the onboard Lithium Ion battery packs or via the mains / DC incoming power using the supplied PSU converter 'brick'. The additional Clarity functionality adds to the existing Zeno product with remote asset tracking via cloud access and Bluetooth accessory connectivity, using GSM & PCS cellular radio, WiFi (802.11bg), GPS and Bluetooth Low Energy radio modules.

Zen-O™ weighs just 4.66 kg and can deliver up to 2 liters per minute of oxygen in either pulse or continuous flow. Zen-O is supplied with variety of accessories, including a carry bag and a pull cart for increased mobility. The carrying case and cart were not used during testing, due to it increasing the distance from the device to the end user.

Frequency ranges of each radio in the device:

- a. Cell: 824 – 849 MHz
- b. PCS: 1850 – 1910 MHz

# PRODUCT DESCRIPTION

## Location of transmit antenna(s):

Cell/PCS  
Antenna

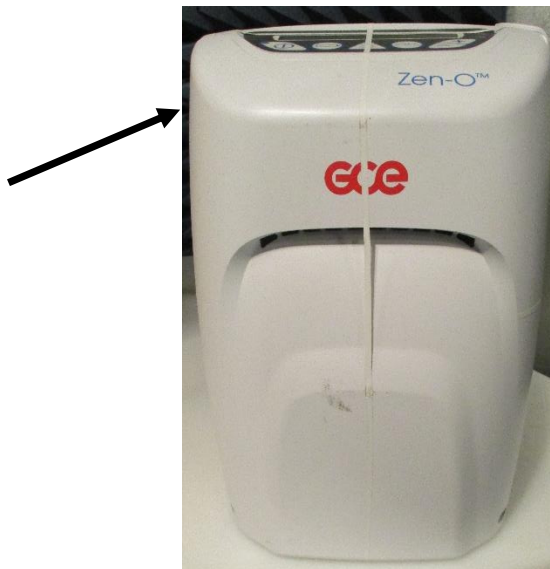

## Testing Locations

Top, back and left of device were tested as the EUTs antennas are located on the left side near the top.

An optional backpack is available for sale with the EUT. Since the backpack does not have any metal, testing was done with a 0 cm spacing to the phantom to show a worst case scenario.

The EUT is meant to only be used against the body and no provisions to be used against the head. EUT was tested in its only operating configuration.

## Simultaneous Transmission

The EUT does not have simultaneous transmission capability.



# PRODUCT DESCRIPTION

## Testing Objective:

To demonstrate compliance of only the Cellular radio with the SAR requirements of FCC 2.1093:2018

## Scaling:

Per FCC KDB 447498, the measured SAR values were scaled to the maximum tune-up tolerance limit. The results are referred to as the “Reported SAR” values. The following formula was used to calculate the linear SAR scaling factor:

$$\text{SAR scaling factor} = 10^{((\text{Maximum Rated Power (dBm)} - \text{Measured Power (dBm)}) / 10)}$$

$$\text{Cell GHz SAR scaling factor} = ( 29.5 - 29.5 ) / 10 = 1$$

$$\text{PCS SAR scaling factor} = ( 27.5 - 27.5 ) / 10 = 1$$

## Duty Cycle

The EUT was transmitting at nearly 100% duty cycle.



# CONFIGURATIONS



## Configuration GCEG0001- 1

EUT			
Description	Manufacturer	Model/Part Number	Serial Number
Portable Oxygen Concentrator	Gas Control Equipment	RS-00500C	ZE100961

## Configuration GCEG0001- 2

EUT			
Description	Manufacturer	Model/Part Number	Serial Number
Portable Oxygen Concentrator	Gas Control Equipment	RS-00500C	ZE100966

# MODIFICATIONS



## Equipment Modifications

Item	Date	Test	Modification	Note	Disposition of EUT
1	2018/02/07	Output Power	Tested as delivered to Test Station.	No EMI suppression devices were added or modified during this test.	EUT remained at Element following the test.
2	2018/02/15	SAR Evaluation	Modified from delivered configuration.	Cel power was reduced by 4dB and PCS power was reduced by 2dB to meet the limits. The EUT was above the limits at the original power setting, Modifications approved by Will Turner	EUT remained at Element following the test.
3	2018/02/21	SAR Evaluation	Tested as delivered to Test Station.	No EMI suppression devices were added or modified during this test.	Scheduled testing was completed.

# TISSUE – EQUIVALENT LIQUID DESCRIPTION



## Characterization of tissue-equivalent liquid dielectric properties

Per IEEE 1528: 2013, Section 5.3.2, the permittivity and conductivity of the tissue material should be measured at least within 24 hours of any full-compliance test. The measured values must be within +/- 5% of the target values. The temperature variation in the liquid during SAR measurements must be within +/- 2 degrees C of that recorded when the dielectric properties were measured.

The dielectric parameters of the tissue-equivalent liquids were measured within 24 hours of the start of testing using the SPEAG DAKS:200 dielectric assessment kit. The dielectric measurements were made across the frequency range of the liquid. The attached data sheets show that the dielectric parameters of the liquid were within the required 5% tolerances.

## Target values of dielectric parameters

Per KDB 865664 D01 v01r04, Appendix A:

“The head tissue dielectric parameters recommended by IEEE Std 1528-2013 have been incorporated in the following table. These head parameters are derived from planar layer models simulating the highest expected SAR for the dielectric properties and tissue thickness variations in a human head. Other head and body tissue parameters that have not been specified in IEEE Std 1528 are derived from tissue dielectric parameters computed from the 4-Cole-Cole equations described above and extrapolated according to the head parameters specified in IEEE Std 1528.”

Target Frequency (MHz)	Head		Body	
	$\epsilon_r$	$\sigma$ (S/m)	$\epsilon_r$	$\sigma$ (S/m)
150	52.3	0.76	61.9	0.80
300	45.3	0.87	58.2	0.92
450	43.5	0.87	56.7	0.94
835	41.5	0.90	55.2	0.97
900	41.5	0.97	55.0	1.05
915	41.5	0.98	55.0	1.06
1450	40.5	1.20	54.0	1.30
1610	40.3	1.29	53.8	1.40
1800 – 2000	40.0	1.40	53.3	1.52
2450	39.2	1.80	52.7	1.95
3000	38.5	2.40	52.0	2.73
5800	35.3	5.27	48.2	6.00

( $\epsilon_r$  = relative permittivity,  $\sigma$  = conductivity and  $\rho = 1000 \text{ kg/m}^3$ )

# TISSUE – EQUIVALENT LIQUID DESCRIPTION



## Composition of Ingredients for Liquid Tissue Phantoms

Element uses tissue-equivalent liquids prepared by SPEAG and confirmed by them to be within +/- 5% from the target values. Their recipes are based upon the following formulations as found in IEEE 1528:2013 Annex C (head) and IEC 62209-2:2010 Annex E (body):

The following tissue formulations are provided for reference only as some of the parameters have not been thoroughly verified. The composition of ingredients may be modified accordingly to achieve the desired target tissue parameters required for routine SAR evaluation:

### HEAD

**Table C.1—Suggested recipes for achieving target dielectric parameters:  
300 MHz to 900 MHz**

Frequency (MHz)	300	450	450	450	835	835	900	900	900	900
Reference	[B118]	[B118]	[B172]	[B74]	[B118]	[B74]	[B118]	[B196]	[B172]	[B74]
<b>Ingredients (% by weight)</b>										
1,2-Propanediol	—	—	—	—	—	—	—	64.81	—	—
Bactericide	0.19	0.19	0.50	—	0.10	—	0.10	—	0.50	—
Diacetin	—	—	48.90	—	—	—	—	—	49.20	—
DGBE	—	—	—	—	—	—	—	—	—	—
HEC	0.98	0.98	—	—	1.00	—	1.00	—	—	—
NaCl	5.95	3.95	1.70	1.96	1.45	1.25	1.48	0.79	1.10	1.35
Sucrose	55.32	56.32	—	—	57.00	—	56.50	—	—	—
Triton X-100	—	—	—	—	—	—	—	—	—	—
Tween 20	—	—	—	49.51	—	48.39	—	—	—	48.34
Water	37.56	38.56	48.90	48.53	40.45	50.36	40.92	34.40	49.20	50.31

**Table C.2—Suggested recipes for achieving target dielectric parameters:  
1450 MHz to 2000 MHz**

Frequency (MHz)	1450	1800	1800	1800	1800	1800	1900	1900	1950	2000
Reference	[B118]	[B118]	[B196]	[B196]	[B172]	[B74]	[B118]	[B196]	[B74]	[B118]
<b>Ingredients (% by weight)</b>										
1,2-Propanediol	—	—	—	—	—	—	—	—	—	—
Bactericide	—	—	—	—	0.50	—	—	—	—	—
Diacetin	—	—	—	—	49.43	—	—	—	—	—
DGBE	45.51	47.00	13.84	44.92	—	—	44.92	13.84	45.00	50.00
HEC	—	—	—	—	—	—	—	—	—	—
NaCl	0.67	0.36	0.35	0.18	0.64	0.50	0.18	0.35	—	—
Sucrose	—	—	—	—	—	—	—	—	—	—
Triton X-100	—	—	30.45	—	—	—	—	30.45	—	—
Tween 20	—	—	—	—	—	45.27	—	—	—	—
Water	53.82	52.64	55.36	54.90	49.43	54.23	54.90	55.36	55.00	50.00

# TISSUE – EQUIVALENT LIQUID DESCRIPTION



**Table C.3—Suggested recipes for achieving target dielectric parameters:  
2100 MHz to 5800 MHz**

Frequency (MHz)	2100	2100	2450	2450	3000	5200	5800
Reference	[B118]	[B196]	[B196]	[B172]	[B196]		
<b>Ingredients (% by weight)</b>							
1,2-Propanediol	—	—	—		—	—	—
Bactericide	—	—	—	0.50	—	—	—
Diacetin	—	—	—	49.75	—	—	—
DGBE	50.00	7.99	7.99	—	7.99	—	—
HEC	—	—	—	—	—	—	—
NaCl	—	0.16	0.16	—	0.16	—	—
Sucrose	—	—	—	—	—	—	—
Triton X-100	—	19.97	19.97	—	19.97	17.24	17.24
Diethylenglycol monohexylether	—	—	—	—	—	17.24	17.24
Water	50.00	71.88	71.88	49.75	71.88	65.52	65.52

## **BODY**

Frequency (MHz)	30	50		144		450		835	900	
Recipe source number	3	3	2	2	3	2	4	2	2	4
<b>Ingredients (% by weight)</b>										
Deionised water	48,30	48,30	53,53	55,12	48,30	48,53	56	50,36	50,31	56
Tween			44,70	43,31		49,51		48,39	48,34	
Oxidised mineral oil							44			44
Diethylenglycol monohexylether										
Triton X-100										
Diacetin	50,00	50,00			50,00					
DGBE										
NaCl	1,60	1,60	1,77	1,57	1,60	1,96		1,25	1,35	
Additives and salt	0,10	0,10			0,10					

Frequency (MHz)	1 800		2 450	4 000	5 000	5 200	5 800	6 000
Recipe source number	2	4	4	4	4	1	1	4
<b>Ingredients (% by weight)</b>								
Deionised water	54,23	56	56	56	56	65,53	65,53	56
Tween	45,27							
Oxidised mineral oil		44	44	44	44			44
Diethylenglycol monohexylether						17,24	17,24	
Triton X-100						17,24	17,24	
Diacetin								
DGBE								
NaCl	0,50							
Additives and salt								



# TISSUE – EQUIVALENT LIQUID

Date:	2018/02/16	Temperature:	21.3°C
Tissue:	Body, MSL1900, 1900MHz	Liquid Temperature:	21.6°C
Tested By:	Travis Pow	Relative Humidity:	33.6%
Job Site:	EV08	Bar. Pressure:	1030 mb

## TEST SPECIFICATIONS

Specification:	Method:
FCC 2.1093:2018	IEEE Std 1528:2013, FCC KDB 865664 D01 v01r04 FCC KDB 865664 D02 v01r02

## RESULTS

Frequency (MHz)	Actual Values		Target Values		Deviation (%)	
	Relative Permittivity	Conductivity	Relative Permittivity	Conductivity	Relative Permittivity	Conductivity
1900	55.08	1.538	53.3	1.52	-3.34	-1.18

Frequency (MHz)	Relative Permittivity	Conductivity
800	58.77	0.483
840	58.72	0.506
880	58.6	0.538
930	58.41	0.575
970	58.26	0.605
1020	58.15	0.645
1060	58.02	0.679
1110	57.82	0.72
1150	57.65	0.75
1190	57.56	0.786
1240	57.39	0.834
1280	57.23	0.866
1330	57.01	0.916
1370	56.9	0.951
1420	56.82	0.999
1460	56.71	1.045
1510	56.5	1.095
1550	56.33	1.137
1590	56.2	1.181
1640	56.05	1.239
1680	55.86	1.28
1730	55.65	1.337
1770	55.55	1.378
1820	55.44	1.44
1860	55.23	1.492
1900	55.08	1.538
1910	55.06	1.548
1950	54.9	1.592
1990	54.75	1.643

# TISSUE – EQUIVALENT LIQUID



Date:	2018/02/16	Temperature:	21.3°C
Tissue:	Body, MSL900, 900MHz	Liquid Temperature:	22°C
Tested By:	Travis Pow	Relative Humidity:	33.6%
Job Site:	EV08	Bar. Pressure:	1030 mb

## TEST SPECIFICATIONS

Specification:	Method:
FCC 2.1093:2018	IEEE Std 1528:2013, FCC KDB 865664 D01 v01r04 FCC KDB 865664 D02 v01r02

## RESULTS

Frequency (MHz)	Actual Values		Target Values		Deviation (%)	
	Relative Permittivity	Conductivity	Relative Permittivity	Conductivity	Relative Permittivity	Conductivity
900	57.06	1.03	55.0	1.05	-3.75	1.9

Frequency (MHz)	Relative Permittivity	Conductivity
800	57.79	0.924
840	57.62	0.961
880	57.27	1.008
900	57.06	1.03
930	56.79	1.061
970	56.45	1.104
1020	56.07	1.161
1060	55.73	1.207
1110	55.28	1.264
1150	54.96	1.304
1190	54.68	1.352
1240	54.28	1.414
1280	53.96	1.465
1330	53.5	1.523
1370	53.14	1.565
1420	52.85	1.627
1460	52.59	1.684
1510	52.2	1.746
1550	51.89	1.796
1590	51.62	1.848
1640	51.27	1.916
1680	50.96	1.962
1730	50.54	2.026
1770	50.31	2.073
1820	50.02	2.144
1860	49.7	2.202
1910	49.42	2.269
1950	49.19	2.318
1990	48.94	2.375



# TISSUE – EQUIVALENT LIQUID

Date:	2018/02/21	Temperature:	22.1°C
Tissue:	Body, MSL900, 900MHz	Liquid Temperature:	21.6°C
Tested By:	Travis Pow	Relative Humidity:	27.5%
Job Site:	EV08	Bar. Pressure:	1030 mb

## TEST SPECIFICATIONS

Specification:	Method:
FCC 2.1093:2018	IEEE Std 1528:2013, FCC KDB 865664 D01 v01r04 FCC KDB 865664 D02 v01r02

## RESULTS

Frequency (MHz)	Actual Values		Target Values		Deviation (%)	
	Relative Permittivity	Conductivity	Relative Permittivity	Conductivity	Relative Permittivity	Conductivity
900	56.76	1.037	55.0	1.05	-3.2	1.24

Frequency (MHz)	Relative Permittivity	Conductivity
800	57.76	0.927
840	57.31	0.969
880	56.98	1.015
900	56.76	1.037
930	56.46	1.068
970	56.11	1.109
1020	55.74	1.164
1060	55.39	1.211
1110	54.91	1.268
1150	54.54	1.307
1190	54.29	1.349
1240	53.93	1.416
1280	53.55	1.466
1330	53.11	1.526
1370	52.79	1.57
1420	52.43	1.629
1460	52.15	1.681
1510	51.74	1.738
1550	51.45	1.78
1590	51.2	1.83
1640	50.91	1.898
1680	50.55	1.948
1730	50.21	2.011
1770	49.98	2.056
1820	49.71	2.126
1860	49.36	2.182
1910	49.01	2.248
1950	48.74	2.292
1990	48.46	2.344



# TISSUE – EQUIVALENT LIQUID



WSTE.2016.12.19

Date:	2018/02/21	Temperature:	22.1°C
Tissue:	Body, MSL1900, 1900MHz	Liquid Temperature:	21.6°C
Tested By:	Travis Pow	Relative Humidity:	27.5%
Job Site:	EV08	Bar. Pressure:	1030 mb

## TEST SPECIFICATIONS

Specification:	Method:
FCC 2.1093:2018	IEEE Std 1528:2013, FCC KDB 865664 D01 v01r04 FCC KDB 865664 D02 v01r02

## RESULTS

Frequency (MHz)	Actual Values		Target Values		Deviation (%)	
	Relative Permittivity	Conductivity	Relative Permittivity	Conductivity	Relative Permittivity	Conductivity
1900	51.91	1.51	53.3	1.52	2.61	0.66

Frequency (MHz)	Relative Permittivity	Conductivity
800	55.9	0.478
840	55.76	0.506
880	55.67	0.538
930	55.42	0.575
970	55.25	0.604
1020	55.16	0.642
1060	55.01	0.676
1110	54.79	0.717
1150	54.61	0.745
1190	54.53	0.775
1240	54.42	0.827
1280	54.24	0.868
1330	53.96	0.912
1370	53.78	0.947
1420	53.61	0.994
1460	53.49	1.037
1510	53.26	1.083
1550	53.09	1.119
1590	52.99	1.16
1640	52.85	1.216
1680	52.64	1.256
1730	52.44	1.309
1770	52.33	1.346
1820	52.23	1.408
1860	52.05	1.462
1900	51.91	1.51
1910	51.88	1.521
1950	51.71	1.561
1990	51.54	1.607

# SAR SYSTEM VERIFICATION DESCRIPTION



## REQUIREMENT

Per IEEE 1528, Section 8.2.1, “System checks are performed prior to compliance tests and the results must always be within  $\pm 10\%$  of the target value corresponding to the test frequency, liquid, and the source used. The target values are 1 g or 10 g averaged SAR values measured on systems having current system validation and calibration status, and using the system check setup as shown in Figure 14. These target values should be determined using a standard source.”

## TEST DESCRIPTION

Within 24 hours of a measurement, then every 72 hours thereafter, Element used the system validation kit (calibrated reference dipole) to test whether the system was operating within its specifications. The validation was performed in the indicated bands by making SAR measurements of the reference dipole with the phantom filled with the tissue-equivalent liquid. First, a signal generator and power amplifier were used to produce a 100mW level as measured with a power meter at the antenna terminals of the dipole (X). Then, the reference dipole was positioned below the bottom of the phantom and centered with its axis parallel to the longest side of the phantom. A low loss and low relative permittivity spacer was used to establish the correct distance between the center axis of the reference dipole and the liquid.

For the reference dipoles, the spacing distance  $s$  is given by:

$s = 15\text{mm}$ ,  $\pm 0.2\text{mm}$  for  $300\text{MHz} \leq f \leq 1000 \text{ MHz}$ :

$s = 10\text{mm}$ ,  $\pm 0.2\text{mm}$  for  $1000\text{MHz} \leq f \leq 6000\text{MHz}$

The measured 1 g and 10 g spatial average SAR values were normalized to a 1W dipole input power for comparison to the calibration data. The results are summarized in the attached table. The deviation is less than 10% in all cases, indicating that the system performance check was within tolerance.

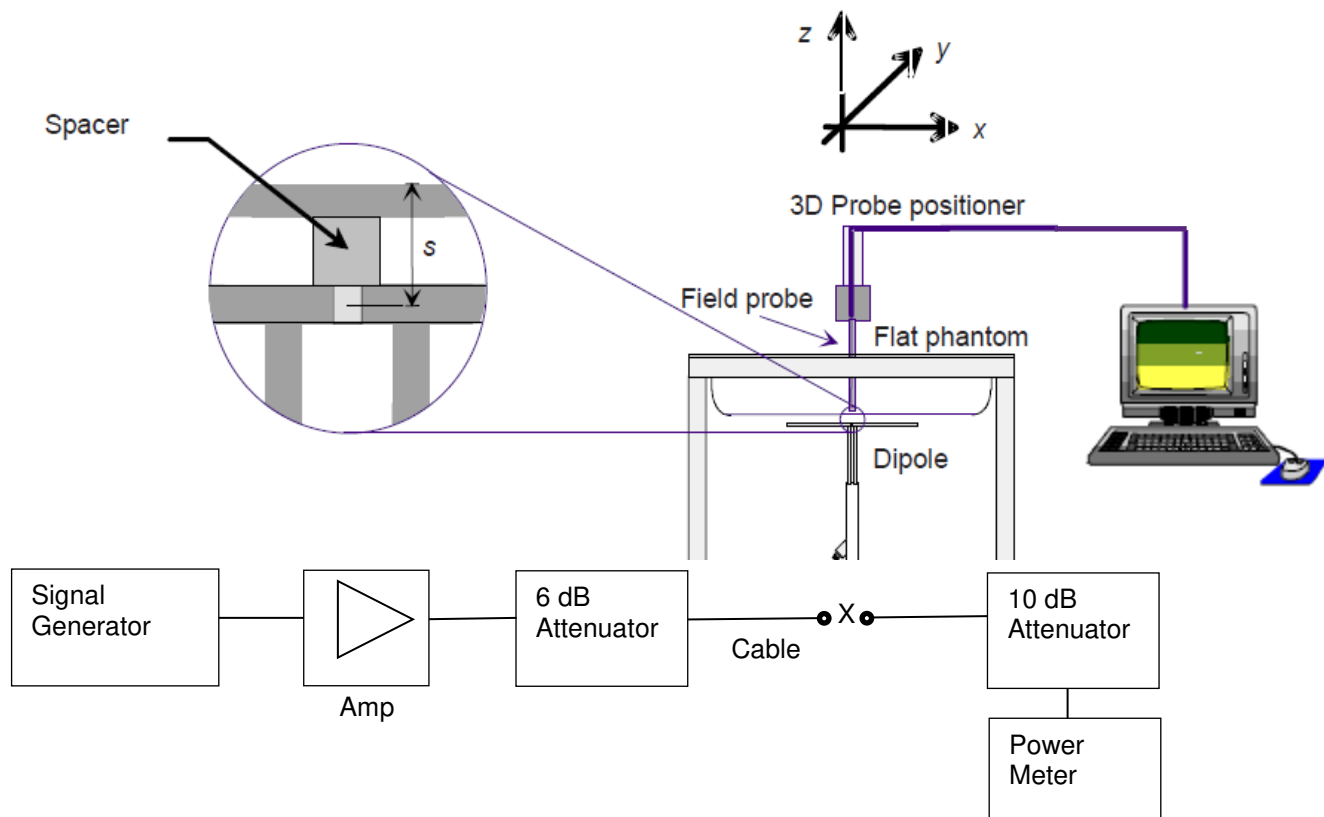

# SAR SYSTEM VERIFICATION



## TEST SPECIFICATIONS

<b>Specification:</b>	<b>Method:</b>
FCC 2.1093:2018	IEEE Std 1528:2013, FCC KDB 865664 D01 v01r04 FCC KDB 865664 D02 v01r02

## RESULTS

Date	Liquid part number and frequency	Conducted Power into the Dipole (dBm)	Correction Factor	Measured		Normalized to 1W		Target (Normalized to 1W) Get from Dipole Calibration Certificate		% Difference	
				1g	10g	1g	10g	1g	10g	1g	10g
2018/02/09	MSL 1900 (1900 MHz)	20.00	10.00	4.07	2.15	40.70	21.50	40.60	21.40	0.25	0.47
2018/02/16	MSL 1900 (1900 MHz)	20.00	10.00	4.08	2.18	40.80	21.80	40.60	21.40	0.49	1.87
2018/02/21	MSL 900 (835 MHz)	20.00	10.00	0.98	0.65	9.80	6.53	9.54	6.23	2.73	4.82
2018/02/21	MSL 1900 (1900 MHz)	20.00	10.00	4.14	2.21	41.40	22.10	40.60	21.40	1.97	3.27

# SAR SYSTEM VERIFICATION



Tested By:	Ethan Schoonover	Room Temperature (°C):	21.6°C
Date:	2018/02/16	Liquid Temperature (°C):	21.6°C
Configuration:	None	Humidity (%RH):	34.5%
		Bar. Pressure (mb):	1030 mb

## MSL1900 System Check PCS1900 2-16-2018

**DUT: Dipole 1900 MHz D1900V2; Type: D1900V2; Serial: D1900V2**

Communication System: UID 0, CW (0); Communication System Band: D1900 (1900.0 MHz); Frequency: 1900 MHz; Communication System PAR: 0 dB; PMF: 1

Medium parameters used:  $\sigma = 0$  S/m,  $\epsilon_r = 1$ ;  $\rho = 1000$  kg/m<sup>3</sup>, Medium parameters used:  $f = 1900$  MHz;  $\sigma = 1.538$  S/m;  $\epsilon_r = 55.077$ ;  $\rho = 1000$  kg/m<sup>3</sup>

Phantom section: Flat Section

Measurement Standard: DASYS5 (IEEE/IEC/ANSI C63.19-2007)

DASY Configuration:

- Probe: ES3DV3 - SN3246; ConvF(4.88, 4.88, 4.88); Calibrated: 2017/11/13;
  - Modulation Compensation:
- Sensor-Surface: 0mm (Fix Surface), Sensor-Surface: 5mm (Mechanical Surface Detection),  $z = 102.0, 32.0$
- Electronics: DAE4 Sn1237; Calibrated: 2017/11/07
- Phantom: ELI v5.0; Type: QDOVA002AA;
- DASYS2 52.8.8(1258); SEMCAD X 14.6.10(7373)

**System Check/System Check/Z Scan (1x1x21):** Measurement grid:  $dx=20$ mm,  $dy=20$ mm,  $dz=5$ mm  
 Maximum value of Total (measured) = 53.99 V/m

**System Check/System Check/Zoom Scan (7x7x7) (7x7x7)/Cube 0:** Measurement grid:  $dx=5$ mm,  $dy=5$ mm,  $dz=5$ mm

Reference Value = 52.64 V/m; Power Drift = -0.02 dB

Peak SAR (extrapolated) = 7.24 W/kg



**SAR(1 g) = 4.08 W/kg; SAR(10 g) = 2.18 W/kg**

Maximum value of SAR (measured) = 4.13 W/kg

**System Check/System Check/Area Scan (71x101x1):** Interpolated grid:  $dx=1.000$  mm,  $dy=1.000$  mm

Maximum value of SAR (interpolated) = 4.19 W/kg

Maximum value of SAR (measured) = 4.48 W/kg

  
 Approved By

# SAR SYSTEM VERIFICATION



MSL1900 System Check PCS1900 2-16-2018

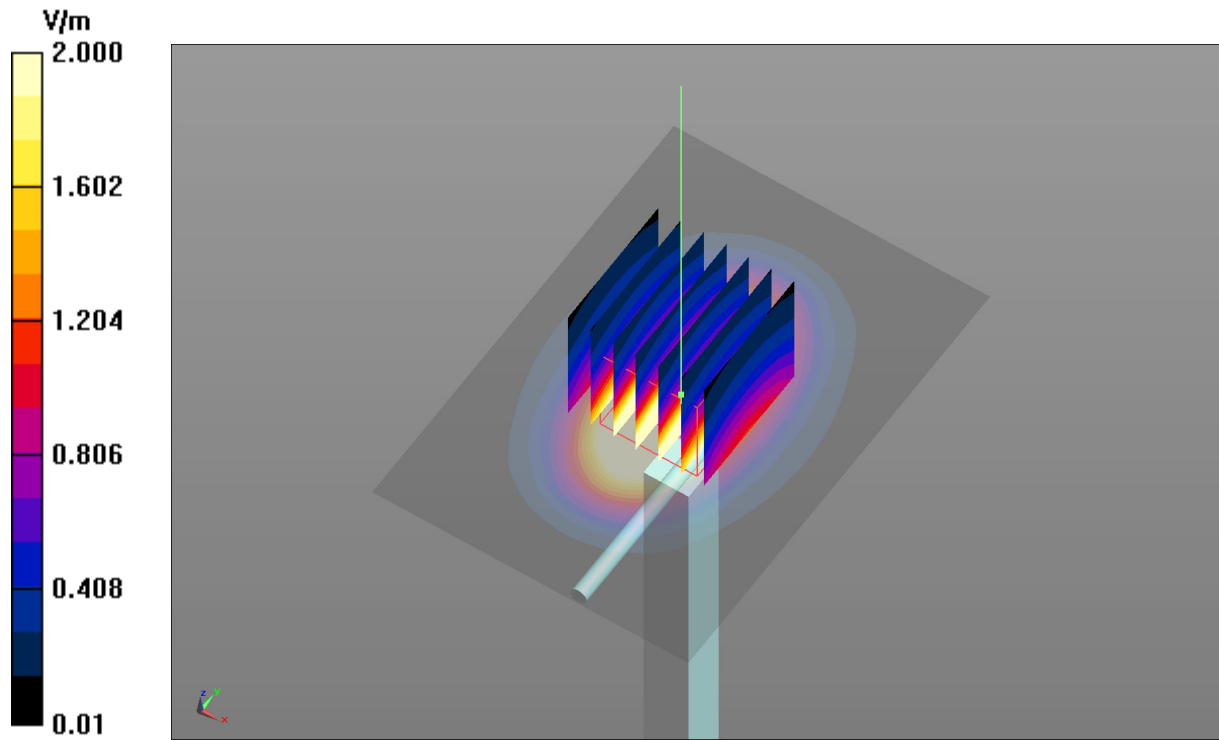

# SAR SYSTEM VERIFICATION



Tested By:	Ethan Schoonover	Room Temperature (°C):	21.6°C
Date:	2018/02/16	Liquid Temperature (°C):	21.6°C
Configuration:	None	Humidity (%RH):	34.5%
		Bar. Pressure (mb):	1030 mb

## MSL900 System Check\_835MHz GSM850 2018-02-16

**DUT: Dipole 835 MHz D835V2; Type: D835V2; Serial: D835V2**

Communication System: UID 10000, CW; Communication System Band: D835 (835.0 MHz); Frequency: 835 MHz; Communication System PAR: 0 dB; PMF: 1

Medium parameters used:  $\sigma = 0$  S/m,  $\epsilon_r = 1$ ;  $\rho = 1000$  kg/m<sup>3</sup>, Medium parameters used (interpolated):  $f = 835$  MHz;  $\sigma = 0.955$  S/m;  $\epsilon_r = 57.654$ ;  $\rho = 1000$  kg/m<sup>3</sup>

Phantom section: Flat Section

Measurement Standard: DASYS5 (IEEE/IEC/ANSI C63.19-2007)

DASY Configuration:

- Probe: ES3DV3 - SN3246; ConvF(6.31, 6.31, 6.31); Calibrated: 2017/11/13;
  - Modulation Compensation:
- Sensor-Surface: 0mm (Fix Surface), Sensor-Surface: 5mm (Mechanical Surface Detection),  $z = 102.0, 32.0$
- Electronics: DAE4 Sn1237; Calibrated: 2017/11/07
- Phantom: ELI v5.0; Type: QDOVA002AA;
- DASYS52 52.8.8(1258); SEMCAD X 14.6.10(7373)

**System Check/System Check/Z Scan (1x1x21):** Measurement grid:  $dx=20$ mm,  $dy=20$ mm,  $dz=5$ mm

[Info: Interpolated medium parameters used for SAR evaluation.](#)

Maximum value of Total (measured) = 32.30 V/m

**System Check/System Check/Zoom Scan (7x7x7) (7x7x7)/Cube 0:** Measurement grid:  $dx=5$ mm,  $dy=5$ mm,  $dz=5$ mm

Reference Value = 32.16 V/m; Power Drift = 0.05 dB

Peak SAR (extrapolated) = 1.44 W/kg

**SAR(1 g) = 0.989 W/kg; SAR(10 g) = 0.658 W/kg**

[Info: Interpolated medium parameters used for SAR evaluation.](#)

Maximum value of SAR (measured) = 0.992 W/kg

**System Check/System Check/Area Scan (71x101x1):** Interpolated grid:  $dx=1.000$  mm,  $dy=1.000$  mm

[Info: Interpolated medium parameters used for SAR evaluation.](#)

Maximum value of SAR (interpolated) = 0.989 W/kg

Maximum value of SAR (measured) = 0.997 W/kg

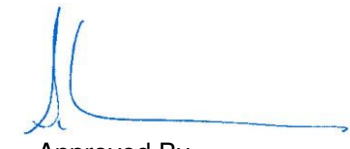
  
 Approved By

# SAR SYSTEM VERIFICATION



MSL900 System Check\_835MHz GSM850 2-16-2018

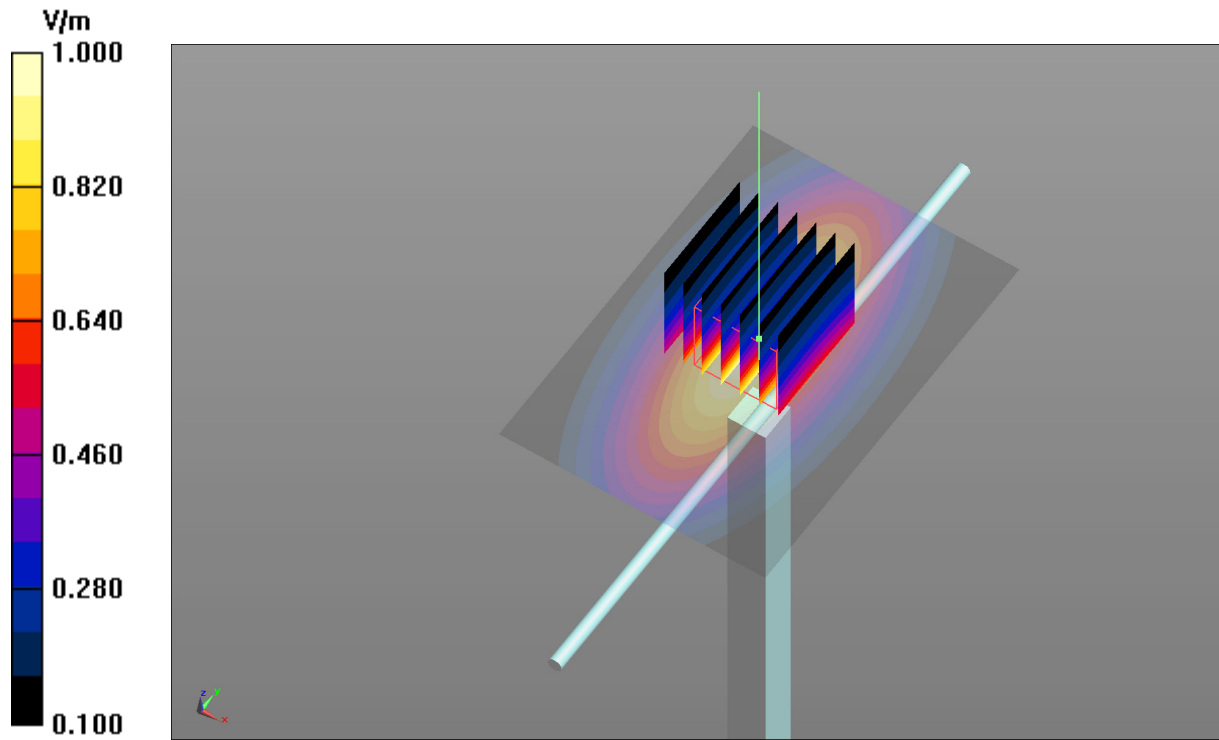

# SAR SYSTEM VERIFICATION



Tested By:	Ethan Schoonover	Room Temperature (°C):	22.1°C
Date:	2018/02/21	Liquid Temperature (°C):	21.6°C
Configuration:	None	Humidity (%RH):	27.4%
		Bar. Pressure (mb):	1029 mb

## MSL900 System Check\_835MHz GSM850 2018-02-21

**DUT: Dipole 835 MHz D835V2; Type: D835V2; Serial: D835V2 - SN:4D108**

Communication System: UID 10000, CW; Communication System Band: D835 (835.0 MHz); Frequency: 835 MHz; Communication System PAR: 0 dB; PMF: 1

Medium parameters used:  $\sigma = 0$  S/m,  $\epsilon_r = 1$ ;  $\rho = 1000$  kg/m<sup>3</sup>, Medium parameters used (interpolated):  $f = 835$  MHz;  $\sigma = 0.963$  S/m;  $\epsilon_r = 57.349$ ;  $\rho = 1000$  kg/m<sup>3</sup>

Phantom section: Flat Section

Measurement Standard: DASYS5 (IEEE/IEC/ANSI C63.19-2007)

DASY Configuration:

- Probe: ES3DV3 - SN3246; ConvF(6.31, 6.31, 6.31); Calibrated: 2017/11/13;
  - Modulation Compensation:
- Sensor-Surface: 0mm (Fix Surface), Sensor-Surface: 5mm (Mechanical Surface Detection),  $z = 102.0, 32.0$
- Electronics: DAE4 Sn1237; Calibrated: 2017/11/07
- Phantom: ELI v5.0; Type: QDOVA002AA;
- DASYS52 52.8.8(1258); SEMCAD X 14.6.10(7373)

**System Check/System Check/Z Scan (1x1x21):** Measurement grid: dx=20mm, dy=20mm, dz=5mm

[Info: Interpolated medium parameters used for SAR evaluation.](#)

Maximum value of Total (measured) = 33.65 V/m

**System Check/System Check/Zoom Scan (7x7x7) (7x7x7)/Cube 0:** Measurement grid: dx=5mm, dy=5mm, dz=5mm

Reference Value = 32.12 V/m; Power Drift = -0.01 dB

Peak SAR (extrapolated) = 1.42 W/kg

**SAR(1 g) = 0.980 W/kg; SAR(10 g) = 0.653 W/kg**

[Info: Interpolated medium parameters used for SAR evaluation.](#)



Maximum value of SAR (measured) = 0.984 W/kg

**System Check/System Check/Area Scan (71x101x1):** Interpolated grid: dx=1.000 mm, dy=1.000 mm

[Info: Interpolated medium parameters used for SAR evaluation.](#)

Maximum value of SAR (interpolated) = 0.979 W/kg

Maximum value of SAR (measured) = 1.09 W/kg



  
 Approved By



# SAR SYSTEM VERIFICATION

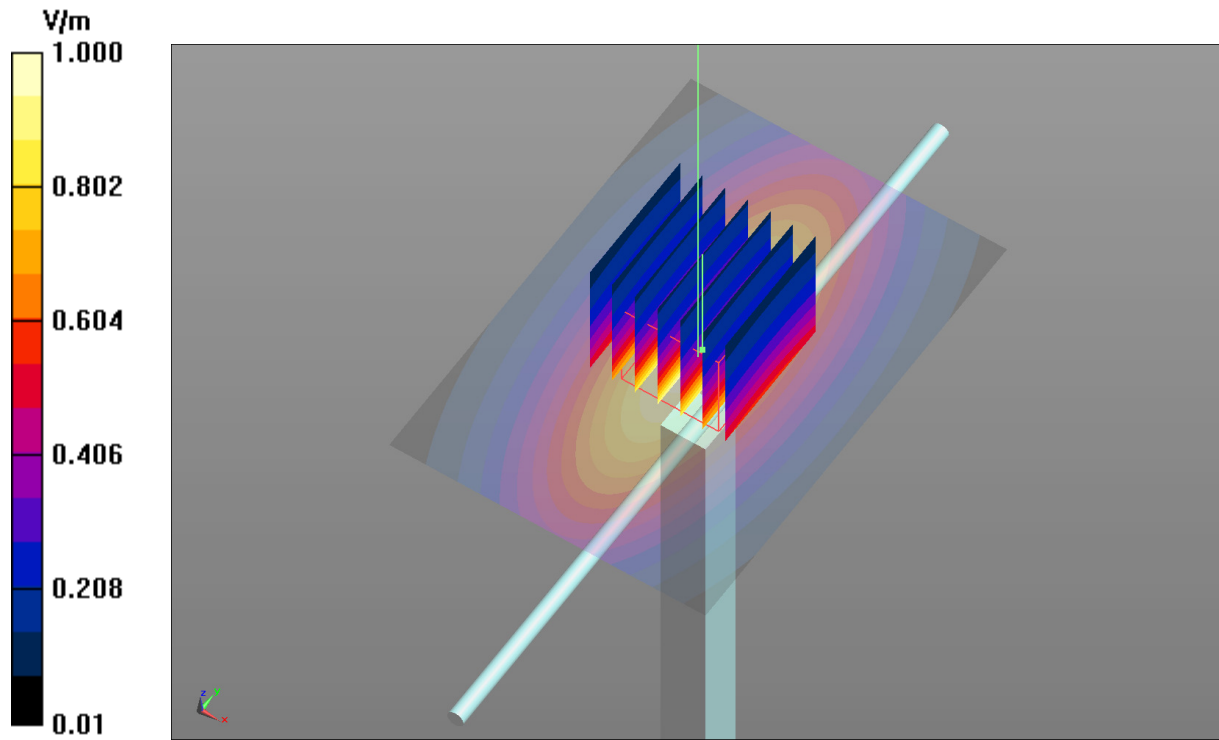

MSL900 System Check\_835MHz GSM850 2-21-2018



# SAR SYSTEM VERIFICATION



Tested By:	Ethan Schoonover	Room Temperature (°C):	22.1°C
Date:	2018/02/21	Liquid Temperature (°C):	21.6°C
Configuration:	None	Humidity (%RH):	27.4%
		Bar. Pressure (mb):	1029 mb

## MSL1900 System Check PCS1900 2018-02-21

**DUT: Dipole 1900 MHz D1900V2; Type: D1900V2; Serial: D1900V2 - SN:xxx**

Communication System: UID 10000, CW; Communication System Band: D1900 (1900.0 MHz); Frequency: 1900 MHz; Communication System PAR: 0 dB; PMF: 1

Medium parameters used:  $f = 1900$  MHz;  $\sigma = 1.57$  S/m;  $\epsilon_r = 51.05$ ;  $\rho = 1000$  kg/m<sup>3</sup>, Medium parameters used:  $\sigma = 0$  S/m,  $\epsilon_r = 1$ ;  $\rho = 1000$  kg/m<sup>3</sup>

Phantom section: Flat Section

Measurement Standard: DASYS5 (IEEE/IEC/ANSI C63.19-2007)

DASY Configuration:

- Probe: ES3DV3 - SN3246; ConvF(4.88, 4.88, 4.88); Calibrated: 2017/11/13;
  - Modulation Compensation:
- Sensor-Surface: 5mm (Mechanical Surface Detection), Sensor-Surface: 0mm (Fix Surface),  $z = 2.0, 32.0, 102.0$
- Electronics: DAE4 Sn1237; Calibrated: 2017/11/07
- Phantom: ELI v5.0; Type: QDOVA002AA;
- DASYS52 52.8.8(1258); SEMCAD X 14.6.10(7373)

**System Check/System Check/Area Scan (51x61x1):** Interpolated grid:  $dx=1.000$  mm,  $dy=1.000$  mm

Maximum value of SAR (interpolated) = 4.26 W/kg

**System Check/System Check/Zoom Scan (7x7x7) (7x7x7)/Cube 0:** Measurement grid:  $dx=5$ mm,  $dy=5$ mm,  $dz=5$ mm

Reference Value = 52.05 V/m; Power Drift = 0.06 dB

Peak SAR (extrapolated) = 7.38 W/kg



**SAR(1 g) = 4.14 W/kg; SAR(10 g) = 2.21 W/kg**

Maximum value of SAR (measured) = 4.18 W/kg

**System Check/System Check/Z Scan (1x1x21):** Measurement grid:  $dx=20$ mm,  $dy=20$ mm,  $dz=5$ mm

Maximum value of Total (measured) = 56.05 V/m

Maximum value of SAR (measured) = 4.93 W/kg

  
 Approved By

# SAR SYSTEM VERIFICATION



MSL1900 System Check PCS1900 2-21-2018

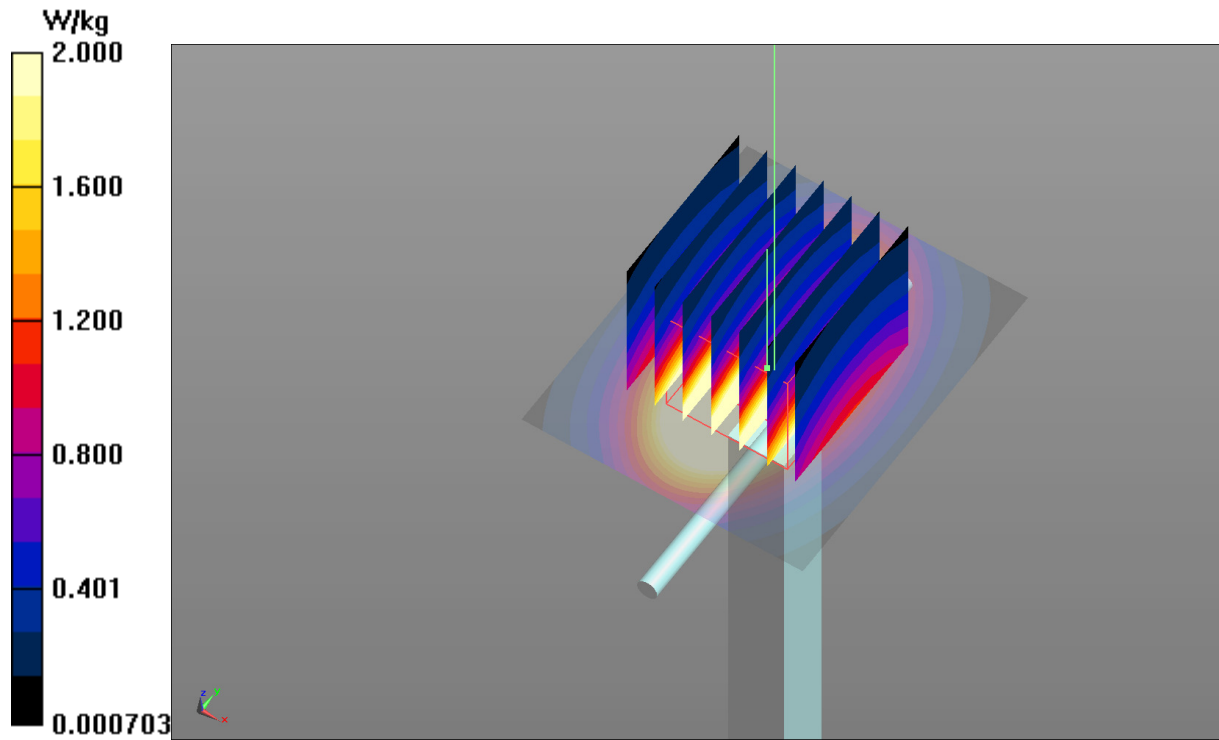



# OUTPUT POWER DESCRIPTION

## **835 MHz and 1900 MHz Bands**

Only the channels and modulation for each band that produced the highest report SAR in the original cellular filings were tested for this configuration.

Output power measurements are on the following pages.

# SAR OUTPUT POWER - GSM/PCS



XMI 2017.12.13

EUT: Zen-O with Clarity		Work Order: GCEG0001
Serial Number: ZE100966		Date: 2018-02-07
Customer: GCE Group		Temperature: 21.8 °C
Attendees: None		Humidity: 27.1% RH
Project: None		Barometric Pres.: 1025 mbar
Tested by: Travis Pow	Power: Battery	Job Site: EV06
<b>TEST SPECIFICATIONS</b>		
FCC 2.1093:2018		Test Method IEEE Std 1528:2013, FCC KDB 941225 D01 v03 FCC KDB 941225 D05 v02r03
<b>COMMENTS</b>		
None		
<b>DEVIATIONS FROM TEST STANDARD</b>		
None		
Configuration #	1	<i>Signature</i> 

GPRS/ 1 slot / GMSK (CS-4)				
Band	Channel	Frequency	Power RMS	Duty Cycle
GSM-850	128	824	29.5	11.1
	190	836.7	29.2	11.1
	251	849	29.1	11.1
PCS-1900	512	1850.2	27.0	12.0
	661	1880	27.3	12.0
	810	1910	27.5	12.0

GPRS/ 4 slot / GMSK (CS-4)				
Band	Channel	Frequency	Power RMS	Duty Cycle
GSM-850	128	824	29.4	44.5
	190	836.7	29.1	44.5
	251	849	29.0	44.5
PCS-1900	512	1850.2	26.8	44.5
	661	1880	27.2	44.5
	810	1910	27.4	44.5

# TEST RESULTS



---

## Test Configurations

### Test Locations

Top, back and left of device were tested as the EUTs antennas are located on the left side near the top.

An optional backpack is available for sale with the EUT. Since the backpack does not have any metal, testing was done with a 0 cm spacing to the phantom to show a worst case scenario.

The EUT is meant to only be used against the body and no provisions to be used against the head. EUT was tested in its only operating configuration.

---

## Summary

Per FCC KDB 447498, the measured SAR values were scaled to the maximum tune-up tolerance limit. The results are referred to as the “Reported SAR” values. The formula that was used to calculate the linear SAR scaling factor is located on page 8.

### Duty Cycle

The EUT was transmitting at nearly 100% duty cycle.

---

# SAR TEST DATA – GSM850



WSTD.2016.12.19

EUT:	Zen-O with Clarity	Work Order:	GCEG0001
Customer:	GCE Group	Job Site:	EV08
Attendees:	None	Customer Project:	None

## TEST SPECIFICATIONS

Specification:	Method:
FCC 2.1093:2018	IEEE Std 1528:2013, FCC KDB 447498 D01 v06 FCC KDB 941225 D01 v03r01 FCC KDB 941225 D05 v02r05 FCC KDB 616217 D04 v01r02 FCC KDB 865664 D01 v01r04 FCC KDB 865664 D02 v01r02

## COMMENTS

None

## DEVIATIONS FROM TEST STANDARD

None

## RESULTS

Test Configuration	Frequency Band	Transmit Frequency (MHz)	Transmit Channel	Modulation Scheme	Slot#	EUT Position	SAR Drift During Test (dB)	Measured 1g SAR Level (W/kg)	Measured 10g SAR Level (W/kg)	SAR Scaling Factor	Scaled 1g SAR Level (W/kg)	Scaled 10g SAR Level (W/kg)	Test#
Body	850 MHz	824	128	CS-4	1	Top	-0.02	0.012	0.008	1	0.012	0.008	10
Body	850 MHz	824	128	CS-4	1	Back	-0.12	0.017	0.012	1	0.017	0.012	11
Body	850 MHz	824	128	CS-4	1	Left	-0.04	1.44	0.917	1	1.44	0.917	12
Body	850 MHz	849	251	CS-4	1	Left	0.04	1.5	0.948	1	1.50	0.948	15
Body	850 MHz	836.7	190	CS-4	1	Left	-0.05	0.02	1.51	1	0.02	1.51	16

## REPEATABILITY

Test Configuration	Frequency Band	Transmit Frequency (MHz)	Transmit Channel	Modulation Scheme	Slot#	EUT Position	SAR Drift During Test (dB)	Measured 1g SAR Level (W/kg)	Measured 10g SAR Level (W/kg)	Repeat#
Body	850 MHz	836.7	190	CS-4	1	Left	0.02	1.51	0.963	1
Body	850 MHz	836.7	190	CS-4	1	Left	-1.77	1.51	0.971	2
Body	850 MHz	836.7	190	CS-4	1	Left	0.02	1.51	0.973	3

# SAR TEST DATA – GSM850



WSTD.2016.12.19

Tested By:	Travis Pow	Room Temperature (°C):	22.3°C
Date:	2018/02/21 11:43:02 AM	Liquid Temperature (°C):	21.6°C
Serial Number:	ZE100966	Humidity (%RH):	27.5%
Configuration:	GCEG0001-1	Bar. Pressure (mb):	1030 mb
Comments:	None		

## Test16 - Repeat 3

**DUT: GCEG0001; Type: D2450V2; Serial: D2450V2**

Communication System: UID 0, CW (0); Communication System Band: D835 (835.0 MHz); Frequency: 836.7 MHz; Communication System PAR: 0 dB; PMF: 1

Medium parameters used (interpolated):  $f = 836.7$  MHz;  $\sigma = 0.965$  S/m;  $\epsilon_r = 57.336$ ;  $\rho = 1000$  kg/m<sup>3</sup>, Medium parameters used:  $\sigma = 0$  S/m,  $\epsilon_r = 1$ ;  $\rho = 1000$  kg/m<sup>3</sup>

Phantom section: Flat Section

Measurement Standard: DASYS5 (IEEE/IEC/ANSI C63.19-2007)

DASY Configuration:

- Probe: ES3DV3 - SN3246; ConvF(6.31, 6.31, 6.31); Calibrated: 2017/11/13;
  - Modulation Compensation:
- Sensor-Surface: 3mm (Mechanical Surface Detection), Sensor-Surface: 0mm (Fix Surface),  $z = 2.0, 32.0, 107.0$
- Electronics: DAE4 Sn1237; Calibrated: 2017/11/07
- Phantom: ELI v5.0; Type: QDOVA002AA;
- DASYS52 52.8.8(1258); SEMCAD X 14.6.10(7373)

**Body/Body/Reference scan (71x111x1):** Interpolated grid:  $dx=3.000$  mm,  $dy=3.000$  mm

[Info: Interpolated medium parameters used for SAR evaluation.](#)

Maximum value of SAR (interpolated) = 2.11 W/kg

**Body/Body/Zoom Scan (5x5x7)/Cube 0:** Measurement grid:  $dx=8$ mm,  $dy=8$ mm,  $dz=5$ mm

Reference Value = 43.74 V/m; Power Drift = 0.02 dB

Peak SAR (extrapolated) = 2.32 W/kg

**SAR(1 g) = 1.51 W/kg; SAR(10 g) = 0.973 W/kg**

[Info: Interpolated medium parameters used for SAR evaluation.](#)

Maximum value of SAR (measured) = 1.73 W/kg

**Body/Body/Area scan (41x41x1):** Interpolated grid:  $dx=1.500$  mm,  $dy=1.500$  mm

[Info: Interpolated medium parameters used for SAR evaluation.](#)

Maximum value of SAR (interpolated) = 1.84 W/kg

**Body/Body/Z Scan (1x1x21):** Measurement grid:  $dx=20$ mm,  $dy=20$ mm,  $dz=5$ mm

[Info: Interpolated medium parameters used for SAR evaluation.](#)

Maximum value of Total (measured) = 35.19 V/m

Maximum value of SAR (measured) = 1.19 W/kg

Approved By



# SAR TEST DATA – GSM850



Test16 - Repeat 3

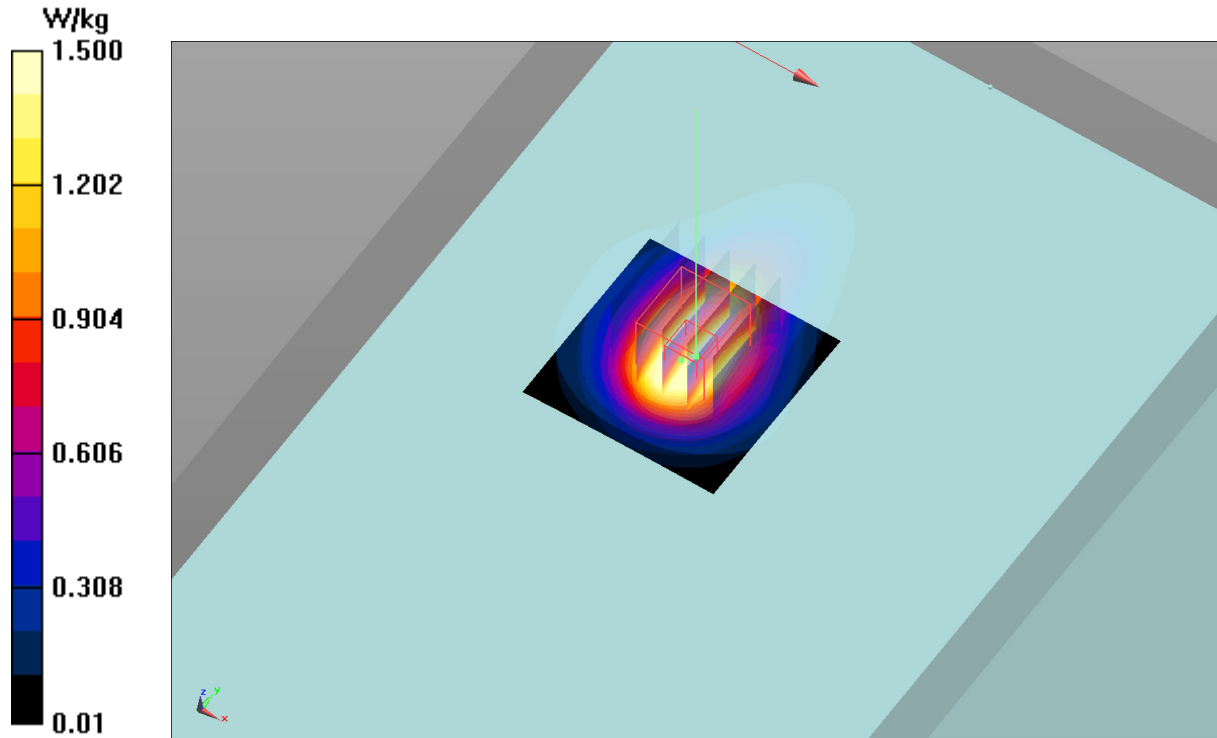

# SAR TEST DATA – GSM850

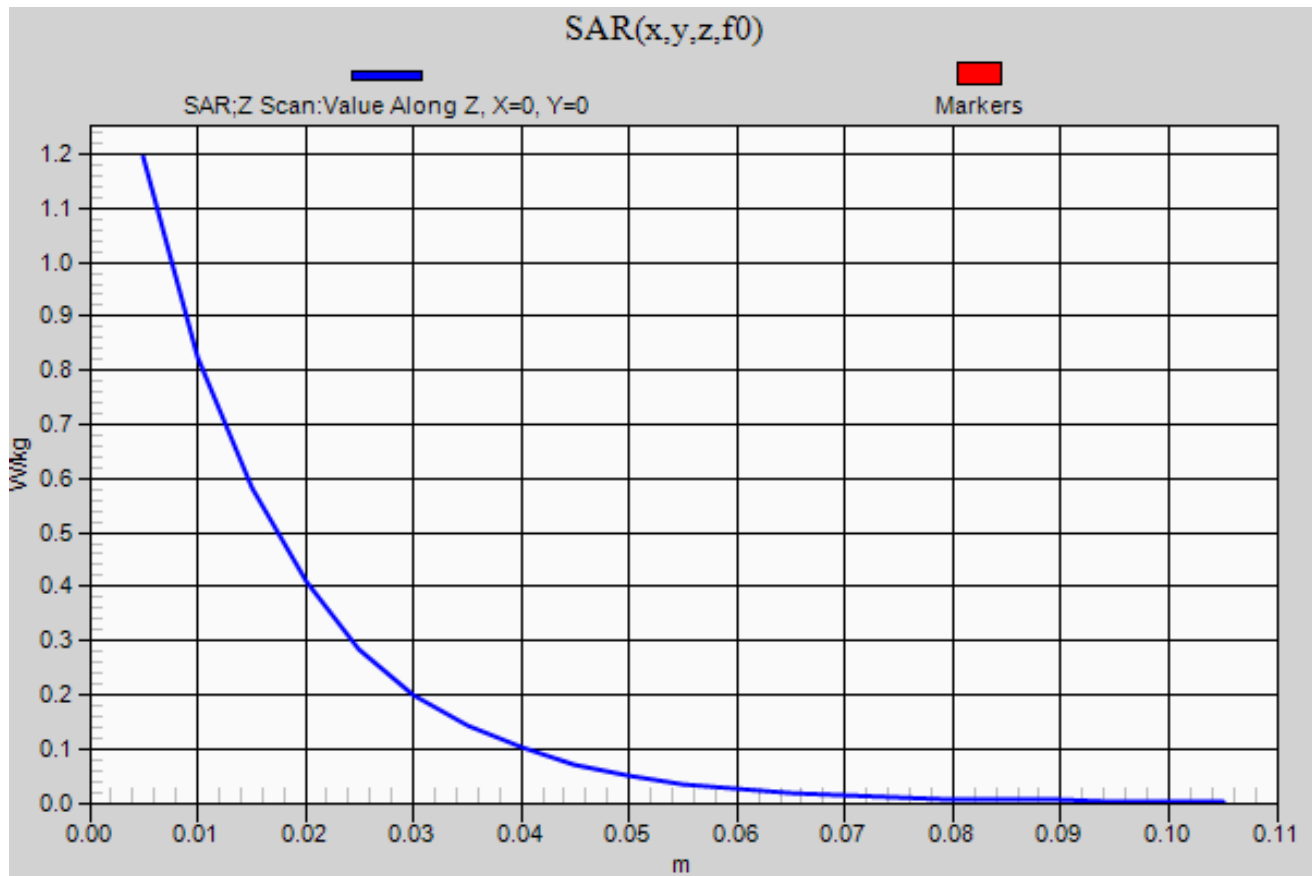

# SAR TEST DATA – PCS1900



WSTD.2016.12.19

EUT:	Zen-O with Clarity	Work Order:	GCEG0001
Customer:	GCE Group	Job Site:	EV08
Attendees:	None	Customer Project:	None

## TEST SPECIFICATIONS

Specification:	Method:
FCC 2.1093:2018	IEEE Std 1528:2013, FCC KDB 447498 D01 v06 FCC KDB 941225 D01 v03r01 FCC KDB 941225 D05 v02r05 FCC KDB 616217 D04 v01r02 FCC KDB 865664 D01 v01r04 FCC KDB 865664 D02 v01r02

## COMMENTS

None

## DEVIATIONS FROM TEST STANDARD

None

## RESULTS

Test Configuration	Frequency Band	Transmit Frequency (MHz)	Transmit Channel	Modulation Scheme	Slot#	EUT Position	SAR Drift During Test (dB)	Measured 1g SAR Level (W/kg)	Measured 10g SAR Level (W/kg)	SAR Scaling Factor	Scaled 1g SAR Level (W/kg)	Scaled 10g SAR Level (W/kg)	Test#
Body	1.9 GHz	1850	512	CS-4	1	Top	0.09	0.004	0.003	1	0.004	0.003	7
Body	1.9 GHz	1850	512	CS-4	1	Back	-8.94	0.005	0.003	1	0.005	0.003	8
Body	1.9 GHz	1850	512	CS-4	1	Left	-0.06	1.35	0.650	1	1.35	0.650	9
Body	1.9 GHz	1910	810	CS-4	1	Left	-0.07	1.41	0.665	1	1.41	0.665	13
Body	1.9 GHz	1880	661	CS-4	1	Left	-0.09	1.30	0.619	1	1.30	0.619	14

## REPEATABILITY

Test Configuration	Frequency Band	Transmit Frequency (MHz)	Transmit Channel	Modulation Scheme	Slot#	EUT Position	SAR Drift During Test (dB)	Measured 1g SAR Level (W/kg)	Measured 10g SAR Level (W/kg)	Repeat#
Body	1.9 GHz	1910	810	CS-4	1	Left	-0.13	1.41	0.658	1
Body	1.9 GHz	1910	810	CS-4	1	Left	-0.10	1.41	0.658	2
Body	1.9 GHz	1910	810	CS-4	1	Left	-0.15	1.41	0.658	3

# SAR TEST DATA – PCS1900



WSTD.2016.12.19

Tested By:	Travis Pow and Ethan Schoonover	Room Temperature (°C):	22.3°C
Date:	2018/02/15 2:59:24 PM	Liquid Temperature (°C):	22°C
Serial Number:	ZE100961	Humidity (%RH):	33%
Configuration:	GCEG0001-1	Bar. Pressure (mb):	1035 mb
Comments:	None		

## Test13

**DUT: GCEG0001; Type: D2450V2; Serial: D2450V2 -**

Communication System: UID 0, CW (0); Communication System Band: D1900 (1900.0 MHz); Frequency: 1910 MHz; Communication System PAR: 0 dB; PMF: 1

Medium parameters used:  $f = 1910$  MHz;  $\sigma = 1.548$  S/m;  $\epsilon_r = 55.058$ ;  $\rho = 1000$  kg/m<sup>3</sup>, Medium parameters used:  $\sigma = 0$  S/m,  $\epsilon_r = 1$ ;  $\rho = 1000$  kg/m<sup>3</sup>

Phantom section: Flat Section

Measurement Standard: DASYS (IEEE/IEC/ANSI C63.19-2007)

DASY Configuration:

- Probe: ES3DV3 - SN3246; ConvF(4.88, 4.88, 4.88); Calibrated: 2017/11/13;
  - Modulation Compensation:
- Sensor-Surface: 3mm (Mechanical Surface Detection), Sensor-Surface: 0mm (Fix Surface),  $z = 2.0, 32.0, 107.0$
- Electronics: DAE4 Sn1237; Calibrated: 2017/11/07
- Phantom: ELI v5.0; Type: QDOVA002AA;
- DASYS2 52.8.8(1258); SEMCAD X 14.6.10(7373)

**Body/Body/Reference scan (71x111x1):** Interpolated grid:  $dx=3.000$  mm,  $dy=3.000$  mm

Maximum value of SAR (interpolated) = 1.44 W/kg

**Body/Body/Zoom Scan (5x5x7)/Cube 0:** Measurement grid:  $dx=8$ mm,  $dy=8$ mm,  $dz=5$ mm

Reference Value = 35.78 V/m; Power Drift = -0.07 dB

Peak SAR (extrapolated) = 2.60 W/kg

**SAR(1 g) = 1.41 W/kg; SAR(10 g) = 0.665 W/kg**

Maximum value of SAR (measured) = 1.83 W/kg



**Body/Body/Area scan (41x41x1):** Interpolated grid:  $dx=1.500$  mm,  $dy=1.500$  mm

Maximum value of SAR (interpolated) = 1.78 W/kg

**Body/Body/Z Scan (1x1x21):** Measurement grid:  $dx=20$ mm,  $dy=20$ mm,  $dz=5$ mm

Maximum value of Total (measured) = 26.36 V/m

Maximum value of SAR (measured) = 1.08 W/kg

  
 Approved By

# SAR TEST DATA – PCS1900



Test13

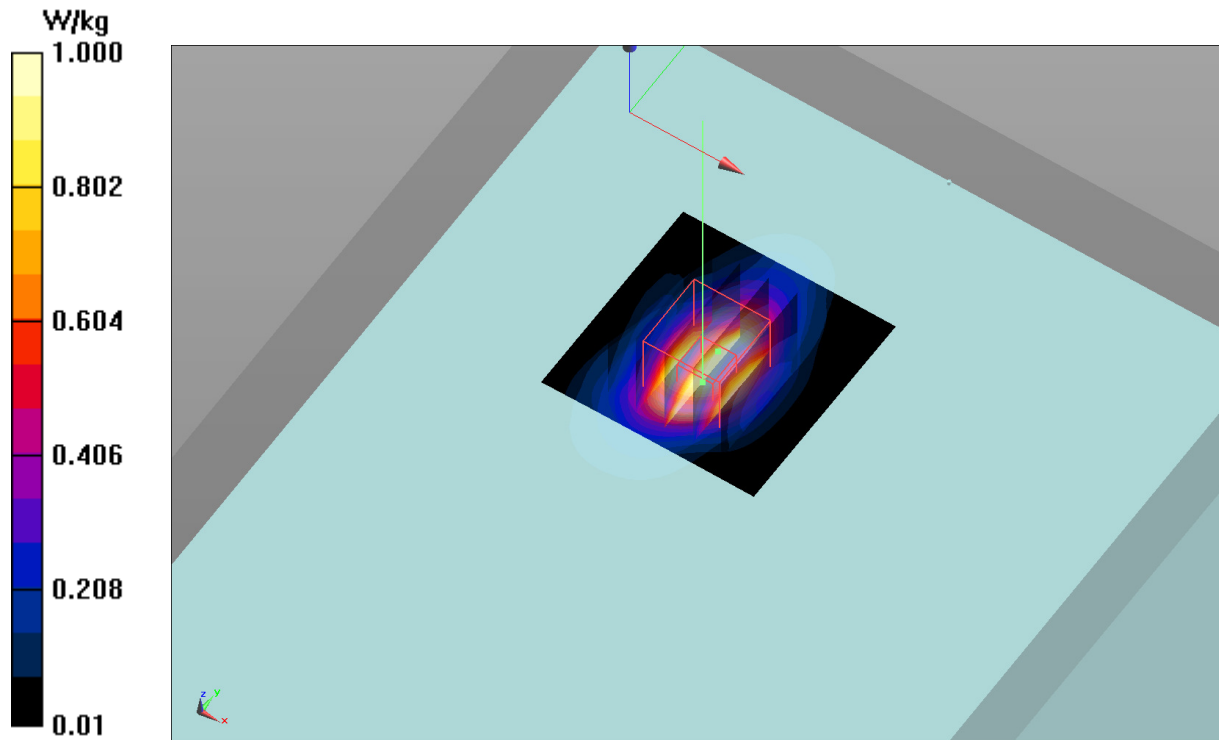

# SAR TEST DATA – PCS1900

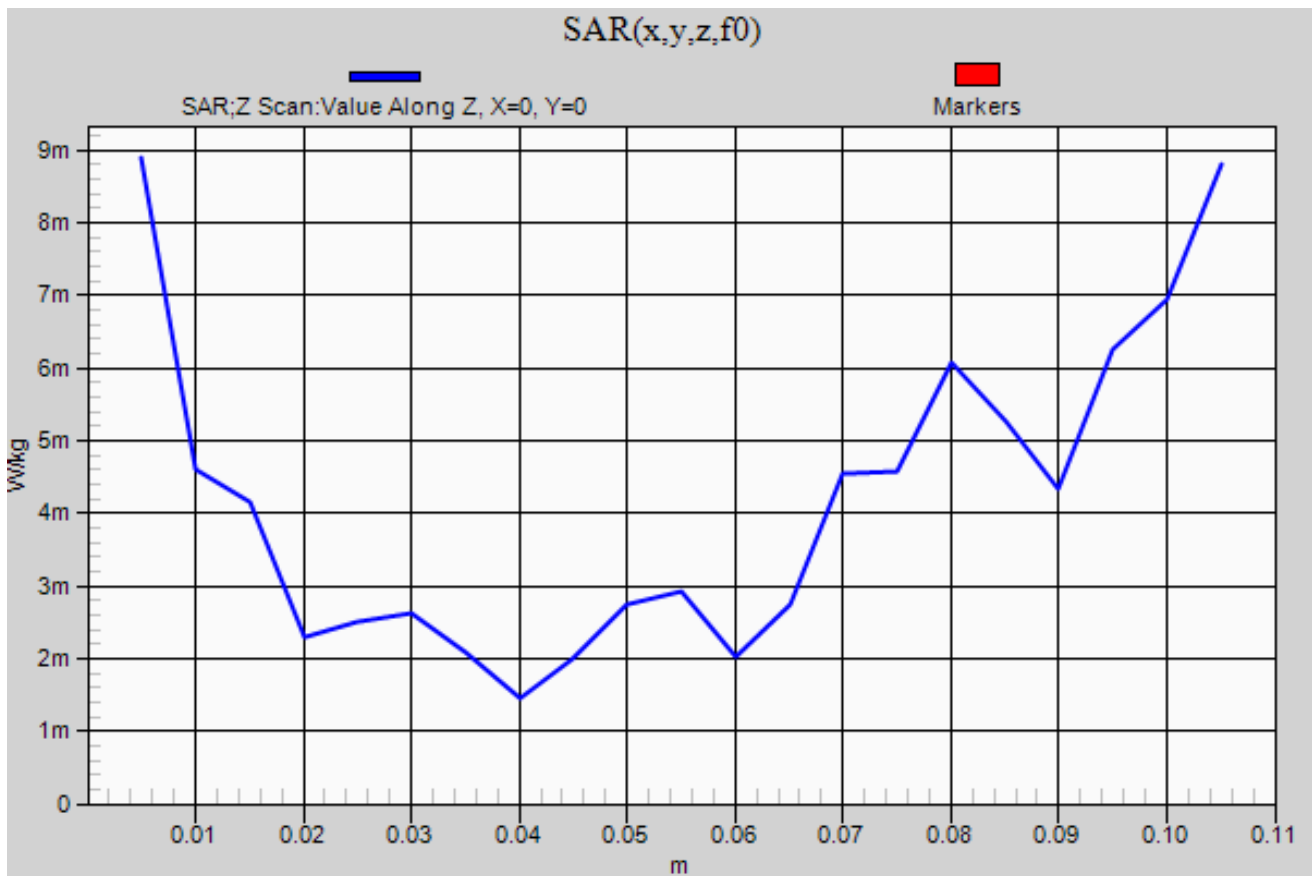

# SYSTEM AND TEST SITE DESCRIPTION



## SAR MEASUREMENT SYSTEM

### Schmid & Partner Engineering AG, DASY52

Element selected the leader in SAR evaluation systems to provide the measurement tools for this evaluation. SPEAG's DASY52 is the fastest and most accurate scanner on the market. It is fully compatible with all world-wide standards for transmitters operating at the ear or within 20cm of the body. It provides full compatibility with IEC 62209-1, IEC 62209-2, IEEE 1528 as well as national adaptations such as FCC OET-65c and Korean Std. MIC #2000-93

The DASY52 system for performing compliance tests consists of the following items:

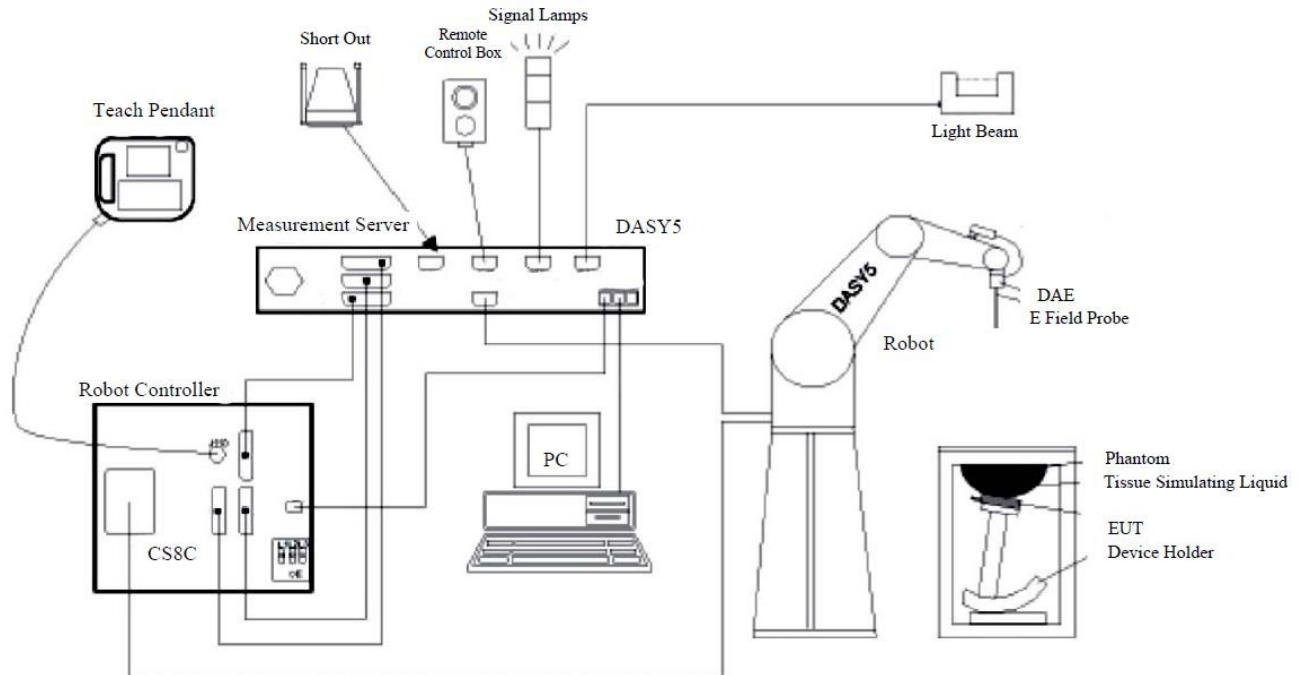

- A standard high precision 6-axis robot (Staubli TX=RX family) with controller, teach pendant and software. An arm extension for accommodating the data acquisition electronics (DAE).
- An isotropic field probe optimized and calibrated for the targeted measurement.
- A data acquisition electronics (DAE) which performs the signal amplification, signal multiplexing, AD-conversion, offset measurements, mechanical surface detection, collision detection, etc. The unit is battery powered with standard or rechargeable batteries. The signal is optically transmitted to the EOC.
- The Electro-optical converter (EOC) performs the conversion from optical to electrical signals for the digital communication to the DAE. To use optical surface detection, a special version of the EOC is required. The EOC signal is transmitted to the measurement server.
- The function of the measurement server is to perform the time critical tasks such as signal filtering, control of the robot operation and fast movement interrupts.
- The Light Beam used is for probe alignment. This improves the (absolute) accuracy of the probe positioning.
- A computer running WinXP and the DASY5 software.
- Remote control and teach pendant as well as additional circuitry for robot safety such as warning lamps, etc.
- The SAM twin phantom, oval flat phantom, device holder, tissue simulating liquids, and validation dipole kits.

# SYSTEM AND TEST SITE DESCRIPTION



## TEST SITE

### Element, Lab EV08

The SAR measurement system is located in a semi-anechoic chamber. This provides an ambient free environment that also eliminates reflections.

The chamber is 12 ft wide by 16 ft long x 8 ft high. A dedicated HVAC unit provides +/- 1 degree C temperature control.

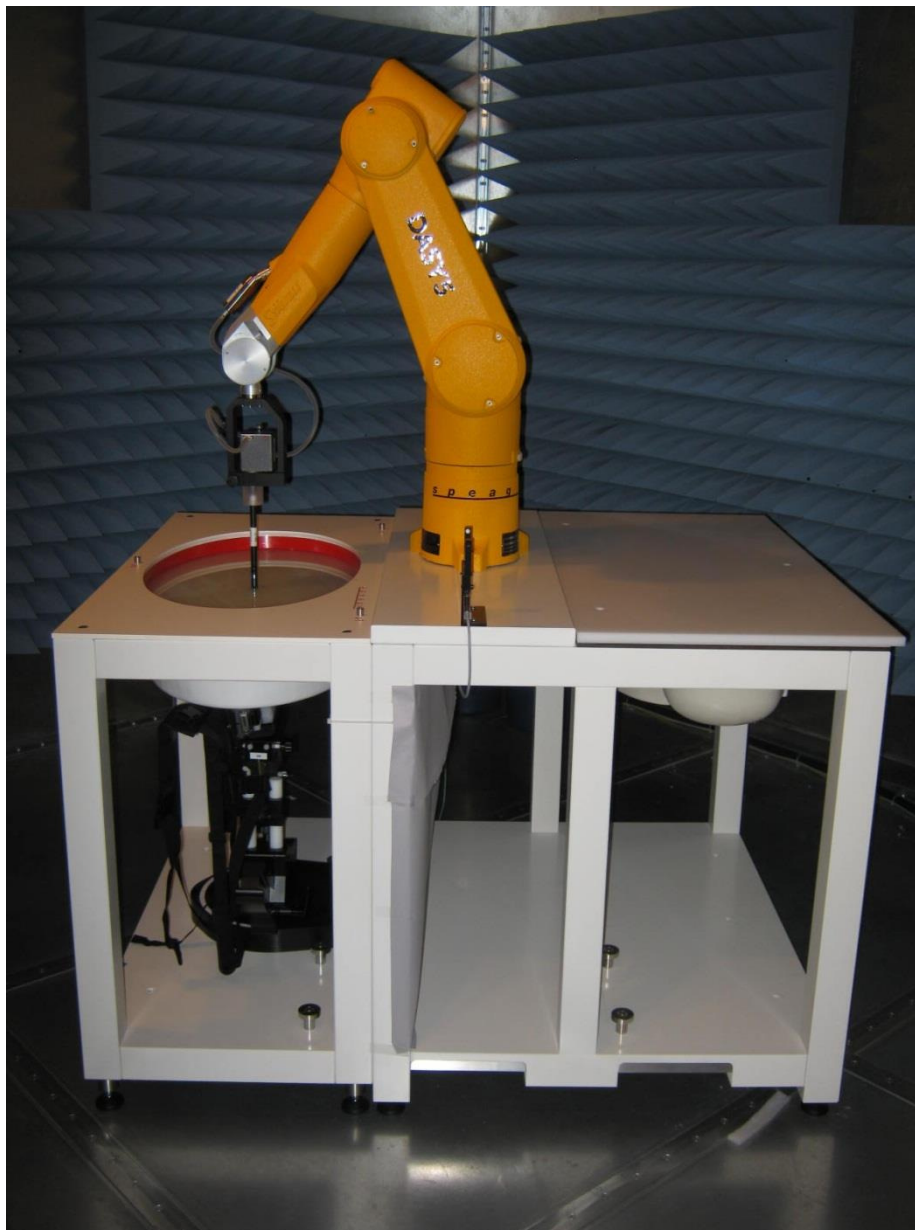



# TEST EQUIPMENT



WSEQ.2016.12.19

## TEST EQUIPMENT

Description	Manufacturer	Model	ID	Last Cal.	Interval
Amplifier	Mini Circuits	ZHL-5W-2G-S+	TRZ	NCR <sup>1</sup>	0 mo
Antenna - Dipole	SPEAG	D835V2	ADK	2017/11/09	12 mo
Antenna - Dipole	SPEAG	D900V2	ADP	2017/11/09	12 mo
Antenna - Dipole	SPEAG	D1900v2	ADO	2017/11/07	12 mo
DAE	SPEAG	SD 000 D04 EJ	SAH	2017/11/07	12 mo
Device Holder	SPEAG	N/A	SAW	NCR	0 mo
Dielectric Assessment Kit	SPEAG	DAKS:200	IPR	2016/03/17	36 mo
Generator - Signal	Agilent	V2920A	TIH	NCR	0 mo
Meter - Power	Agilent	N1913A	SQR	2017/10/12	12 mo
Power Sensor	Agilent	E9300H	SQO	2017/10/12	12 mo
Probe - Dielectric	SPEAG	DAKS-3.5	IPRA	2016/11/01	36 mo
Probe - SAR	SPEAG	ES3DV3	SAF	2017/11/13	12 mo
SAR - Tissue Test Solution	SPEAG	MSL 900	SAT	At start of testing	
SAR - Tissue Test Solution	SPEAG	MSL 1900	SAO	At start of testing	
SAR Test System	Staeubli	DAYS5	SAK	2016/11/01	36 mo
SAR Test System	SPEAG	QD OVA 001 BB	SAC	NCR	0 mo
Thermometer	Omega Engineering, Inc.	HH311	DUI	2018/02/15	36 mo
Thermometer	Omegaette	HH311	DTY	2018/01/05	36 mo
Universal Radio Communication Tester	Agilent	E5515C	BSV	NCR	0 mo

Note 1: The output of the signal generator / amplifier is verified with the calibrated power meter listed above.

# MEASUREMENT UNCERTAINTY



## MEASUREMENT UNCERTAINTY BUDGETS PER IEEE 1528:2013

### 300-3000 MHz Range

Uncertainty Component	Tolerance (+/- %)	Probability Distribution	Divisor	$c_i$ (1g)	$c_i$ (10g)	$u_i$ (1g) (+/-%)	$u_i$ (10g) (+/-%)	$v_i$
<b>Measurement System</b>								
Probe calibration (k=1)	5.5	normal	1	1	1	5.5	5.5	$\infty$
Axial isotropy	4.7	rectangular	1.732	0.707	0.707	1.9	1.9	$\infty$
Hemispherical isotropy	9.6	rectangular	1.732	0.707	0.707	3.9	3.9	$\infty$
Boundary effect	1.0	rectangular	1.732	1	1	0.6	0.6	$\infty$
Linearity	4.7	rectangular	1.732	1	1	2.7	2.7	$\infty$
System detection limits	1.0	rectangular	1.732	1	1	0.6	0.6	$\infty$
Readout electronics	0.3	normal	1	1	1	0.3	0.3	$\infty$
Response time	0.8	rectangular	1.732	1	1	0.5	0.5	$\infty$
Integration time	2.6	rectangular	1.732	1	1	1.5	1.5	$\infty$
RF ambient conditions - noise	1.7	rectangular	1.732	1	1	1.0	1.0	$\infty$
RF Ambient Reflections	0.0	rectangular	1.732	1	1	0.0	0.0	$\infty$
Probe positioner mechanical tolerance	0.4	rectangular	1.732	1	1	0.2	0.2	$\infty$
Probe positioner with respect to phantom shell	2.9	rectangular	1.732	1	1	1.7	1.7	$\infty$
Extrapolation, interpolation, and integration algorithms for max. SAR evaluation	1.0	rectangular	1.732	1	1	0.6	0.6	$\infty$
<b>Test Sample Related</b>								
Device Positioning	2.9	normal	1	1	1	2.9	2.9	145
Device Holder	3.6	normal	1	1	1	3.6	3.6	5
Power Drift	5.0	rectangular	1.732	1	1	2.9	2.9	$\infty$
<b>Phantom and tissue parameters</b>								
Phantom Uncertainty - shell thickness tolerances	4.0	rectangular	1.732	1	1	2.3	2.3	$\infty$
Liquid conductivity - deviation from target values	5.0	rectangular	1.732	0.64	0.43	1.8	1.2	$\infty$
Liquid conductivity - measurement uncertainty	6.5	normal	1	0.64	0.43	4.2	2.8	$\infty$
Liquid permittivity - deviation from target values	5.0	rectangular	1.732	0.6	0.49	1.7	1.4	$\infty$
Liquid permittivity - measurement uncertainty	3.2	normal	1	0.6	0.49	1.9	1.6	$\infty$
Combined Standard Uncertainty	RSS					11.2	10.6	387
Expanded Measurement Uncertainty (95% Confidence/	normal (k=2)					22.5	21.2	

**Calibration Laboratory of  
Schmid & Partner  
Engineering AG**  
Zeughausstrasse 43, 8004 Zurich, Switzerland



**S** Schweizerischer Kalibrierdienst  
**S** Service suisse d'étalonnage  
**C** Servizio svizzero di taratura  
**S** Swiss Calibration Service

Accredited by the Swiss Accreditation Service (SAS)  
The Swiss Accreditation Service is one of the signatories to the EA  
Multilateral Agreement for the recognition of calibration certificates

Accreditation No.: **SCS 0108**

Client **Element**

Certificate No. **D835V2-4d108\_Nov17**

## CALIBRATION CERTIFICATE

Object **D835V2 - SN:4d108**

Calibration procedure(s) **QA CAL-05.v9  
Calibration procedure for dipole validation kits above 700 MHz**

Calibration date: **November 09, 2017**

This calibration certificate documents the traceability to national standards, which realize the physical units of measurements (SI).  
The measurements and the uncertainties with confidence probability are given on the following pages and are part of the certificate.

All calibrations have been conducted in the closed laboratory facility: environment temperature ( $22 \pm 3$ )°C and humidity < 70%.

Calibration Equipment used (M&TE critical for calibration)

Primary Standards	ID #	Cal Date (Certificate No.)	Scheduled Calibration
Power meter NRP	SN: 104778	04-Apr-17 (No. 217-02521/02522)	Apr-18
Power sensor NRP-Z91	SN: 103244	04-Apr-17 (No. 217-02521)	Apr-18
Power sensor NRP-Z91	SN: 103245	04-Apr-17 (No. 217-02522)	Apr-18
Reference 20 dB Attenuator	SN: 5058 (20k)	07-Apr-17 (No. 217-02528)	Apr-18
Type-N mismatch combination	SN: 5047.2 / 06327	07-Apr-17 (No. 217-02529)	Apr-18
Reference Probe EX3DV4	SN: 7349	31-May-17 (No. EX3-7349_May17)	May-18
DAE4	SN: 601	26-Oct-17 (No. DAE4-601_Oct17)	Oct-18
Secondary Standards	ID #	Check Date (in house)	Scheduled Check
Power meter EPM-442A	SN: GB37480704	07-Oct-15 (in house check Oct-16)	In house check: Oct-18
Power sensor HP 8481A	SN: US37292783	07-Oct-15 (in house check Oct-16)	In house check: Oct-18
Power sensor HP 8481A	SN: MY41092317	07-Oct-15 (in house check Oct-16)	In house check: Oct-18
RF generator R&S SMT-06	SN: 100972	15-Jun-15 (in house check Oct-16)	In house check: Oct-18
Network Analyzer HP 8753E	SN: US37390585	18-Oct-01 (in house check Oct-17)	In house check: Oct-18

Calibrated by:	Name	Function	Signature
	Claudio Leubler	Laboratory Technician	
Approved by:	Katja Pokovic	Technical Manager	

Issued: November 9, 2017

This calibration certificate shall not be reproduced except in full without written approval of the laboratory.



Accredited by the Swiss Accreditation Service (SAS)  
The Swiss Accreditation Service is one of the signatories to the EA  
Multilateral Agreement for the recognition of calibration certificates

Accreditation No.: **SCS 0108**

**Glossary:**

TSL	tissue simulating liquid
ConvF	sensitivity in TSL / NORM x,y,z
N/A	not applicable or not measured

**Calibration is Performed According to the Following Standards:**

- IEEE Std 1528-2013, "IEEE Recommended Practice for Determining the Peak Spatial-Averaged Specific Absorption Rate (SAR) in the Human Head from Wireless Communications Devices: Measurement Techniques", June 2013
- IEC 62209-1, "Measurement procedure for the assessment of Specific Absorption Rate (SAR) from hand-held and body-mounted devices used next to the ear (frequency range of 300 MHz to 6 GHz)", July 2016
- IEC 62209-2, "Procedure to determine the Specific Absorption Rate (SAR) for wireless communication devices used in close proximity to the human body (frequency range of 30 MHz to 6 GHz)", March 2010
- KDB 865664, "SAR Measurement Requirements for 100 MHz to 6 GHz"

**Additional Documentation:**

- DASY4/5 System Handbook

**Methods Applied and Interpretation of Parameters:**

- Measurement Conditions:* Further details are available from the Validation Report at the end of the certificate. All figures stated in the certificate are valid at the frequency indicated.
- Antenna Parameters with TSL:* The dipole is mounted with the spacer to position its feed point exactly below the center marking of the flat phantom section, with the arms oriented parallel to the body axis.
- Feed Point Impedance and Return Loss:* These parameters are measured with the dipole positioned under the liquid filled phantom. The impedance stated is transformed from the measurement at the SMA connector to the feed point. The Return Loss ensures low reflected power. No uncertainty required.
- Electrical Delay:* One-way delay between the SMA connector and the antenna feed point. No uncertainty required.
- SAR measured:* SAR measured at the stated antenna input power.
- SAR normalized:* SAR as measured, normalized to an input power of 1 W at the antenna connector.
- SAR for nominal TSL parameters:* The measured TSL parameters are used to calculate the nominal SAR result.

The reported uncertainty of measurement is stated as the standard uncertainty of measurement multiplied by the coverage factor  $k=2$ , which for a normal distribution corresponds to a coverage probability of approximately 95%.

## Measurement Conditions

DASY system configuration, as far as not given on page 1.

<b>DASY Version</b>	DASY5	V52.10.0
<b>Extrapolation</b>	Advanced Extrapolation	
<b>Phantom</b>	Modular Flat Phantom	
<b>Distance Dipole Center - TSL</b>	15 mm	with Spacer
<b>Zoom Scan Resolution</b>	dx, dy, dz = 5 mm	
<b>Frequency</b>	835 MHz ± 1 MHz	

## Head TSL parameters

The following parameters and calculations were applied.

	Temperature	Permittivity	Conductivity
<b>Nominal Head TSL parameters</b>	22.0 °C	41.5	0.90 mho/m
<b>Measured Head TSL parameters</b>	(22.0 ± 0.2) °C	41.6 ± 6 %	0.92 mho/m ± 6 %
<b>Head TSL temperature change during test</b>	< 0.5 °C	---	---

## SAR result with Head TSL

<b>SAR averaged over 1 cm<sup>3</sup> (1 g) of Head TSL</b>	Condition	
SAR measured	250 mW input power	2.41 W/kg
SAR for nominal Head TSL parameters	normalized to 1W	<b>9.49 W/kg ± 17.0 % (k=2)</b>

<b>SAR averaged over 10 cm<sup>3</sup> (10 g) of Head TSL</b>	condition	
SAR measured	250 mW input power	1.55 W/kg
SAR for nominal Head TSL parameters	normalized to 1W	<b>6.12 W/kg ± 16.5 % (k=2)</b>

## Body TSL parameters

The following parameters and calculations were applied.

	Temperature	Permittivity	Conductivity
<b>Nominal Body TSL parameters</b>	22.0 °C	55.2	0.97 mho/m
<b>Measured Body TSL parameters</b>	(22.0 ± 0.2) °C	54.1 ± 6 %	1.01 mho/m ± 6 %
<b>Body TSL temperature change during test</b>	< 0.5 °C	---	---

## SAR result with Body TSL

<b>SAR averaged over 1 cm<sup>3</sup> (1 g) of Body TSL</b>	Condition	
SAR measured	250 mW input power	2.47 W/kg
SAR for nominal Body TSL parameters	normalized to 1W	<b>9.54 W/kg ± 17.0 % (k=2)</b>

<b>SAR averaged over 10 cm<sup>3</sup> (10 g) of Body TSL</b>	condition	
SAR measured	250 mW input power	1.60 W/kg
SAR for nominal Body TSL parameters	normalized to 1W	<b>6.23 W/kg ± 16.5 % (k=2)</b>

## Appendix (Additional assessments outside the scope of SCS 0108)

### Antenna Parameters with Head TSL

Impedance, transformed to feed point	51.4 $\Omega$ - 3.4 j $\Omega$
Return Loss	- 28.8 dB

### Antenna Parameters with Body TSL

Impedance, transformed to feed point	48.3 $\Omega$ - 5.8 j $\Omega$
Return Loss	- 24.2 dB

### General Antenna Parameters and Design

Electrical Delay (one direction)	1.393 ns
----------------------------------	----------

After long term use with 100W radiated power, only a slight warming of the dipole near the feedpoint can be measured.

The dipole is made of standard semirigid coaxial cable. The center conductor of the feeding line is directly connected to the second arm of the dipole. The antenna is therefore short-circuited for DC-signals. On some of the dipoles, small end caps are added to the dipole arms in order to improve matching when loaded according to the position as explained in the "Measurement Conditions" paragraph. The SAR data are not affected by this change. The overall dipole length is still according to the Standard.

No excessive force must be applied to the dipole arms, because they might bend or the soldered connections near the feedpoint may be damaged.

### Additional EUT Data

Manufactured by	SPEAG
Manufactured on	May 26, 2010

# DASY5 Validation Report for Head TSL

Date: 09.11.2017

Test Laboratory: SPEAG, Zurich, Switzerland

**DUT: Dipole 835 MHz; Type: D835V2; Serial: D835V2 - SN:4d108**

Communication System: UID 0 - CW; Frequency: 835 MHz

Medium parameters used:  $f = 835$  MHz;  $\sigma = 0.92$  S/m;  $\epsilon_r = 41.6$ ;  $\rho = 1000$  kg/m<sup>3</sup>

Phantom section: Flat Section

Measurement Standard: DASY5 (IEEE/IEC/ANSI C63.19-2011)

DASY52 Configuration:

- Probe: EX3DV4 - SN7349; ConvF(10.07, 10.07, 10.07); Calibrated: 31.05.2017;
- Sensor-Surface: 1.4mm (Mechanical Surface Detection)
- Electronics: DAE4 Sn601; Calibrated: 26.10.2017
- Phantom: Flat Phantom 4.9 (front); Type: QD 00L P49 AA; Serial: 1001
- DASY52 52.10.0(1446); SEMCAD X 14.6.10(7417)

## Dipole Calibration for Head Tissue/Pin=250 mW, d=15mm/Zoom Scan (7x7x7)/Cube 0:

Measurement grid: dx=5mm, dy=5mm, dz=5mm

Reference Value = 62.21 V/m; Power Drift = 0.00 dB

Peak SAR (extrapolated) = 3.79 W/kg

**SAR(1 g) = 2.41 W/kg; SAR(10 g) = 1.55 W/kg**

Maximum value of SAR (measured) = 3.30 W/kg

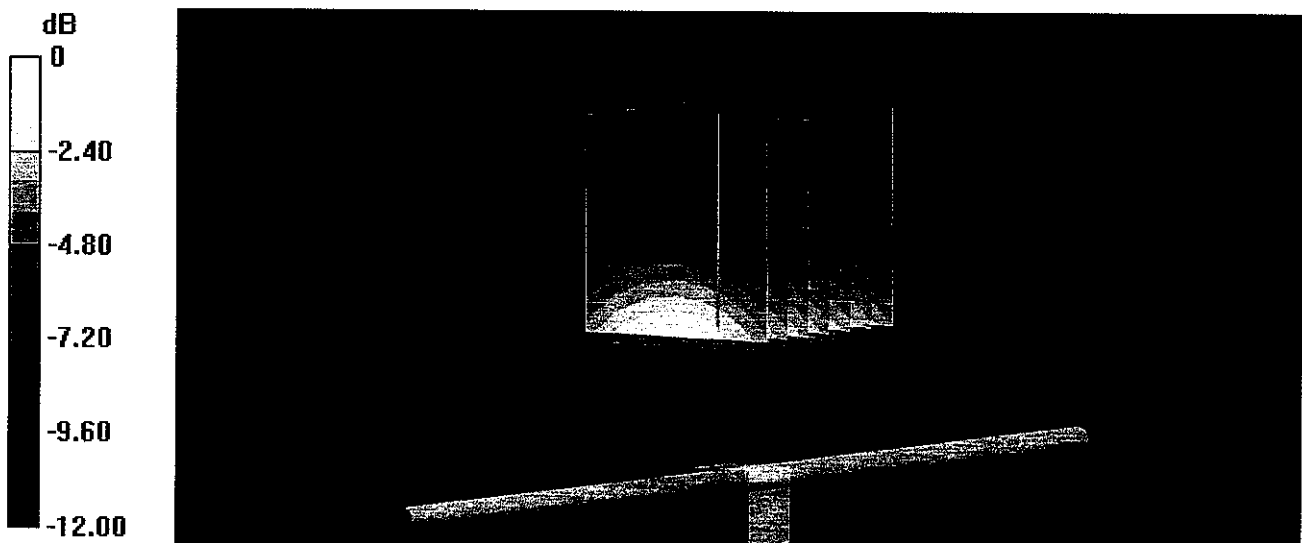

0 dB = 3.30 W/kg = 5.19 dBW/kg

# Impedance Measurement Plot for Head TSL

9 Nov 2017 12:52:24  
 CH1 S11 1 U FS 1: 51.367  $\Omega$  -3.3926  $\Omega$  56.183 pF 835.000 000 MHz

\*  
 De1  
 CA  
 Avg  
 16  
 H1d

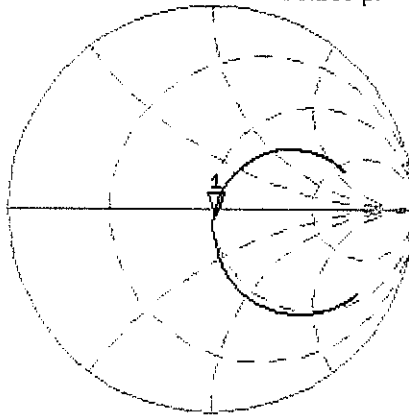

CH2 S11 LOG 5 dB/REF -20 dB 1: -28.850 dB 835.000 000 MHz

CA  
 Avg  
 16  
 H1d

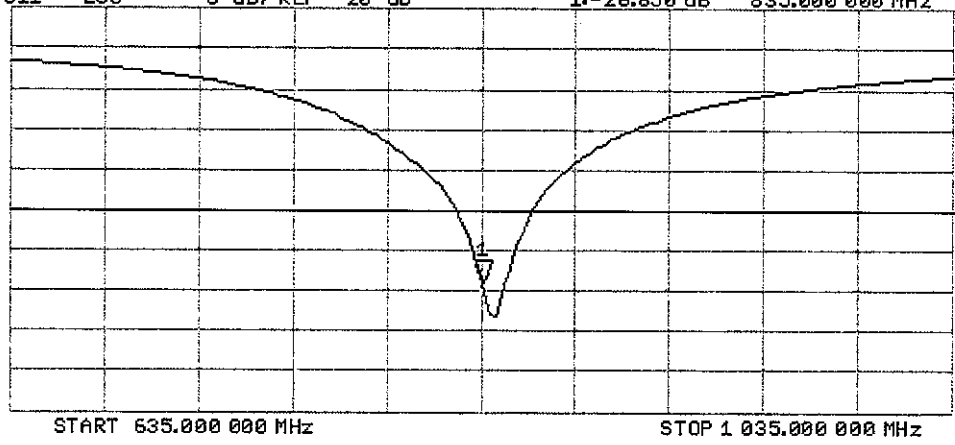



# DASY5 Validation Report for Body TSL

Date: 09.11.2017

Test Laboratory: SPEAG, Zurich, Switzerland

**DUT: Dipole 835 MHz; Type: D835V2; Serial: D835V2 - SN:4d108**

Communication System: UID 0 - CW; Frequency: 835 MHz

Medium parameters used:  $f = 835 \text{ MHz}$ ;  $\sigma = 1.01 \text{ S/m}$ ;  $\epsilon_r = 54.1$ ;  $\rho = 1000 \text{ kg/m}^3$

Phantom section: Flat Section

Measurement Standard: DASY5 (IEEE/IEC/ANSI C63.19-2011)

DASY52 Configuration:

- Probe: EX3DV4 - SN7349; ConvF(10.2, 10.2, 10.2); Calibrated: 31.05.2017;
- Sensor-Surface: 1.4mm (Mechanical Surface Detection)
- Electronics: DAE4 Sn601; Calibrated: 26.10.2017
- Phantom: Flat Phantom 4.9 (Back); Type: QD 00R P49 AA; Serial: 1005
- DASY52 52.10.0(1446); SEMCAD X 14.6.10(7417)

**Dipole Calibration for Body Tissue/Pin=250 mW, d=15mm/Zoom Scan (7x7x7)/Cube 0:**

Measurement grid:  $dx=5\text{mm}$ ,  $dy=5\text{mm}$ ,  $dz=5\text{mm}$

Reference Value = 60.00 V/m; Power Drift = -0.02 dB

Peak SAR (extrapolated) = 3.76 W/kg

**SAR(1 g) = 2.47 W/kg; SAR(10 g) = 1.6 W/kg**

Maximum value of SAR (measured) = 3.29 W/kg

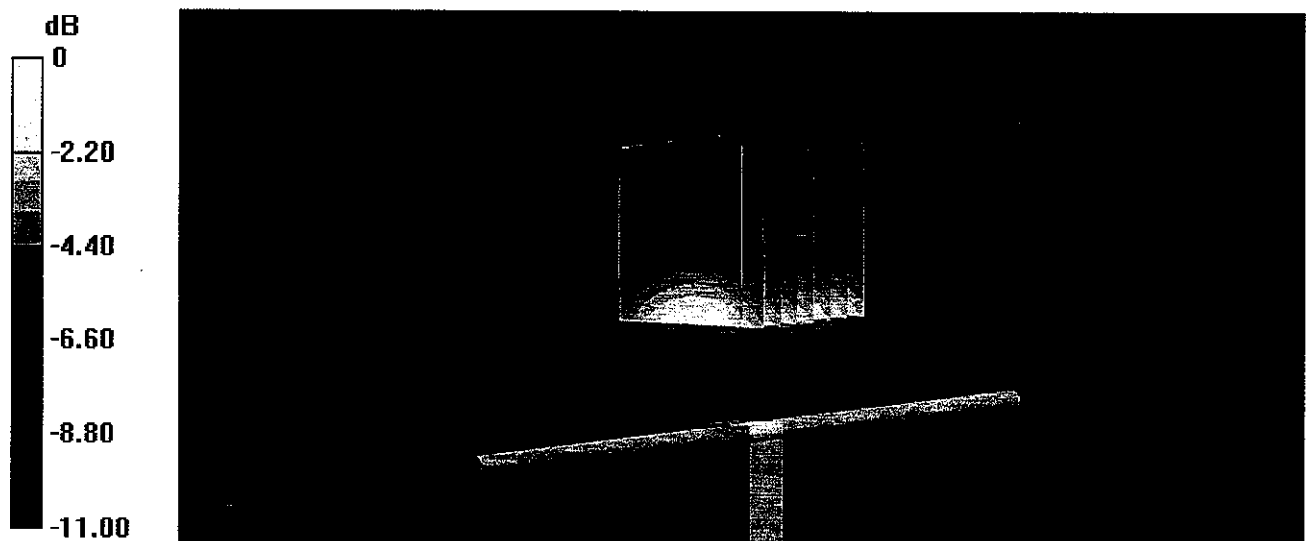

0 dB = 3.29 W/kg = 5.17 dBW/kg

# Impedance Measurement Plot for Body TSL

9 Nov 2017 12:51:44  
 [CH1] S11 1 U FS 1: 48.270  $\Omega$  -5.7930  $\Omega$  32.903 pF 835.000 000 MHz

\*  
 Del  
 CA  
 Avg  
 16  
 H1d

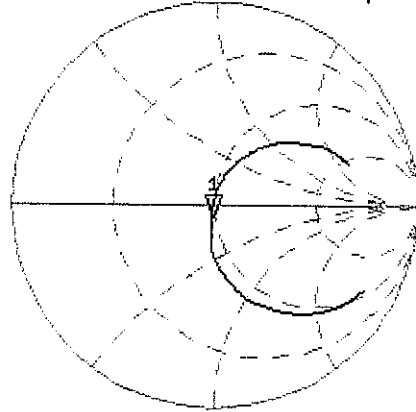

CH2 S11 LOG 5 dB/REF -20 dB 1:-24.237 dB 835.000 000 MHz

CA  
 Avg  
 16  
 H1d

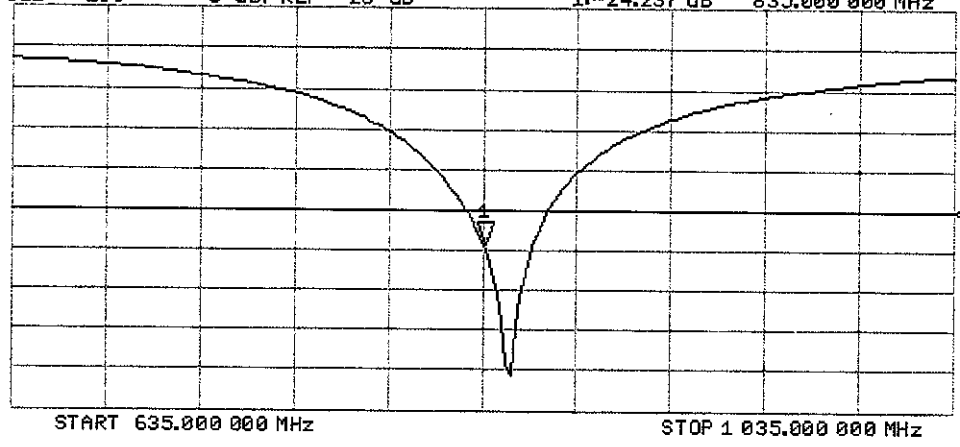

**Calibration Laboratory of**  
**Schmid & Partner**  
**Engineering AG**  
 Zeughausstrasse 43, 8004 Zurich, Switzerland



**S** Schweizerischer Kalibrierdienst  
**S** Service suisse d'étalonnage  
**C** Servizio svizzero di taratura  
**S** Swiss Calibration Service

Accredited by the Swiss Accreditation Service (SAS)  
 The Swiss Accreditation Service is one of the signatories to the EA  
 Multilateral Agreement for the recognition of calibration certificates

Accreditation No.: **SCS 0108**

Client **Element**

Certificate No: **D1900V2-5d131\_Nov17**

## CALIBRATION CERTIFICATE

Object **D1900V2 - SN:5d131**

Calibration procedure(s) **QA CAL-05.v9**  
**Calibration procedure for dipole validation kits above 700 MHz**

Calibration date: **November 07, 2017**

This calibration certificate documents the traceability to national standards, which realize the physical units of measurements (SI).  
 The measurements and the uncertainties with confidence probability are given on the following pages and are part of the certificate.

All calibrations have been conducted in the closed laboratory facility: environment temperature ( $22 \pm 3$ )°C and humidity < 70%.

Calibration Equipment used (M&TE critical for calibration)

Primary Standards	ID #	Cal Date (Certificate No.)	Scheduled Calibration
Power meter NRP	SN: 104778	04-Apr-17 (No. 217-02521/02522)	Apr-18
Power sensor NRP-Z91	SN: 103244	04-Apr-17 (No. 217-02521)	Apr-18
Power sensor NRP-Z91	SN: 103245	04-Apr-17 (No. 217-02522)	Apr-18
Reference 20 dB Attenuator	SN: 5058 (20k)	07-Apr-17 (No. 217-02528)	Apr-18
Type-N mismatch combination	SN: 5047.2 / 06327	07-Apr-17 (No. 217-02529)	Apr-18
Reference Probe EX3DV4	SN: 7349	31-May-17 (No. EX3-7349_May17)	May-18
DAE4	SN: 601	26-Oct-17 (No. DAE4-601_Oct17)	Oct-18

Secondary Standards	ID #	Check Date (in house)	Scheduled Check
Power meter EPM-442A	SN: GB37480704	07-Oct-15 (in house check Oct-16)	In house check: Oct-18
Power sensor HP 8481A	SN: US37292783	07-Oct-15 (in house check Oct-16)	In house check: Oct-18
Power sensor HP 8481A	SN: MY41092317	07-Oct-15 (in house check Oct-16)	In house check: Oct-18
RF generator R&S SMT-06	SN: 100972	15-Jun-15 (in house check Oct-16)	In house check: Oct-18
Network Analyzer HP 8753E	SN: US37390585	18-Oct-01 (in house check Oct-17)	In house check: Oct-18

Calibrated by: **Leif Klysner**      **Leif Klysner**      **Leif Klysner**  
 Name      Function      Signature  
 Laboratory Technician

Approved by: **Katja Pokovic**      **Katja Pokovic**  
 Name      Technical Manager

Issued: November 8, 2017

This calibration certificate shall not be reproduced except in full without written approval of the laboratory.



Accredited by the Swiss Accreditation Service (SAS)  
The Swiss Accreditation Service is one of the signatories to the EA  
Multilateral Agreement for the recognition of calibration certificates

Accreditation No.: **SCS 0108**

**Glossary:**

TSL	tissue simulating liquid
ConvF	sensitivity in TSL / NORM x,y,z
N/A	not applicable or not measured

**Calibration is Performed According to the Following Standards:**

- a) IEEE Std 1528-2013, "IEEE Recommended Practice for Determining the Peak Spatial-Averaged Specific Absorption Rate (SAR) in the Human Head from Wireless Communications Devices: Measurement Techniques", June 2013
- b) IEC 62209-1, "Measurement procedure for the assessment of Specific Absorption Rate (SAR) from hand-held and body-mounted devices used next to the ear (frequency range of 300 MHz to 6 GHz)", July 2016
- c) IEC 62209-2, "Procedure to determine the Specific Absorption Rate (SAR) for wireless communication devices used in close proximity to the human body (frequency range of 30 MHz to 6 GHz)", March 2010
- d) KDB 865664, "SAR Measurement Requirements for 100 MHz to 6 GHz"

**Additional Documentation:**

- e) DASY4/5 System Handbook

**Methods Applied and Interpretation of Parameters:**

- *Measurement Conditions:* Further details are available from the Validation Report at the end of the certificate. All figures stated in the certificate are valid at the frequency indicated.
- *Antenna Parameters with TSL:* The dipole is mounted with the spacer to position its feed point exactly below the center marking of the flat phantom section, with the arms oriented parallel to the body axis.
- *Feed Point Impedance and Return Loss:* These parameters are measured with the dipole positioned under the liquid filled phantom. The impedance stated is transformed from the measurement at the SMA connector to the feed point. The Return Loss ensures low reflected power. No uncertainty required.
- *Electrical Delay:* One-way delay between the SMA connector and the antenna feed point. No uncertainty required.
- *SAR measured:* SAR measured at the stated antenna input power.
- *SAR normalized:* SAR as measured, normalized to an input power of 1 W at the antenna connector.
- *SAR for nominal TSL parameters:* The measured TSL parameters are used to calculate the nominal SAR result.

The reported uncertainty of measurement is stated as the standard uncertainty of measurement multiplied by the coverage factor  $k=2$ , which for a normal distribution corresponds to a coverage probability of approximately 95%.

## Measurement Conditions

DASY system configuration, as far as not given on page 1.

DASY Version	DASY5	V52.10.0
Extrapolation	Advanced Extrapolation	
Phantom	Modular Flat Phantom	
Distance Dipole Center - TSL	10 mm	with Spacer
Zoom Scan Resolution	dx, dy, dz = 5 mm	
Frequency	1900 MHz $\pm$ 1 MHz	

## Head TSL parameters

The following parameters and calculations were applied.

	Temperature	Permittivity	Conductivity
Nominal Head TSL parameters	22.0 °C	40.0	1.40 mho/m
Measured Head TSL parameters	(22.0 $\pm$ 0.2) °C	39.5 $\pm$ 6 %	1.38 mho/m $\pm$ 6 %
Head TSL temperature change during test	< 0.5 °C	----	----

## SAR result with Head TSL

SAR averaged over 1 cm <sup>3</sup> (1 g) of Head TSL	Condition	
SAR measured	250 mW input power	10.1 W/kg
SAR for nominal Head TSL parameters	normalized to 1W	<b>40.6 W/kg <math>\pm</math> 17.0 % (k=2)</b>

SAR averaged over 10 cm <sup>3</sup> (10 g) of Head TSL	condition	
SAR measured	250 mW input power	5.27 W/kg
SAR for nominal Head TSL parameters	normalized to 1W	<b>21.2 W/kg <math>\pm</math> 16.5 % (k=2)</b>

## Body TSL parameters

The following parameters and calculations were applied.

	Temperature	Permittivity	Conductivity
Nominal Body TSL parameters	22.0 °C	53.3	1.52 mho/m
Measured Body TSL parameters	(22.0 $\pm$ 0.2) °C	54.1 $\pm$ 6 %	1.46 mho/m $\pm$ 6 %
Body TSL temperature change during test	< 0.5 °C	----	----

## SAR result with Body TSL

SAR averaged over 1 cm <sup>3</sup> (1 g) of Body TSL	Condition	
SAR measured	250 mW input power	9.88 W/kg
SAR for nominal Body TSL parameters	normalized to 1W	<b>40.6 W/kg <math>\pm</math> 17.0 % (k=2)</b>

SAR averaged over 10 cm <sup>3</sup> (10 g) of Body TSL	condition	
SAR measured	250 mW input power	5.27 W/kg
SAR for nominal Body TSL parameters	normalized to 1W	<b>21.4 W/kg <math>\pm</math> 16.5 % (k=2)</b>

## Appendix (Additional assessments outside the scope of SCS 0108)

### Antenna Parameters with Head TSL

Impedance, transformed to feed point	51.2 $\Omega$ + 5.4 j $\Omega$
Return Loss	- 25.2 dB

### Antenna Parameters with Body TSL

Impedance, transformed to feed point	46.5 $\Omega$ + 5.3 j $\Omega$
Return Loss	- 23.6 dB

### General Antenna Parameters and Design

Electrical Delay (one direction)	1.205 ns
----------------------------------	----------

After long term use with 100W radiated power, only a slight warming of the dipole near the feedpoint can be measured.

The dipole is made of standard semirigid coaxial cable. The center conductor of the feeding line is directly connected to the second arm of the dipole. The antenna is therefore short-circuited for DC-signals. On some of the dipoles, small end caps are added to the dipole arms in order to improve matching when loaded according to the position as explained in the "Measurement Conditions" paragraph. The SAR data are not affected by this change. The overall dipole length is still according to the Standard.

No excessive force must be applied to the dipole arms, because they might bend or the soldered connections near the feedpoint may be damaged.

### Additional EUT Data

Manufactured by	SPEAG
Manufactured on	April 14, 2010

# DASY5 Validation Report for Head TSL

Date: 07.11.2017

Test Laboratory: SPEAG, Zurich, Switzerland

**DUT: Dipole 1900 MHz; Type: D1900V2; Serial: D1900V2 - SN:5d131**

Communication System: UID 0 - CW; Frequency: 1900 MHz

Medium parameters used:  $f = 1900$  MHz;  $\sigma = 1.38$  S/m;  $\epsilon_r = 39.5$ ;  $\rho = 1000$  kg/m<sup>3</sup>

Phantom section: Flat Section

Measurement Standard: DASY5 (IEEE/IEC/ANSI C63.19-2011)

DASY52 Configuration:

- Probe: EX3DV4 - SN7349; ConvF(8.43, 8.43, 8.43); Calibrated: 31.05.2017;
- Sensor-Surface: 1.4mm (Mechanical Surface Detection)
- Electronics: DAE4 Sn601; Calibrated: 26.10.2017
- Phantom: Flat Phantom 5.0 (front); Type: QD 000 P50 AA; Serial: 1001
- DASY52 52.10.0(1446); SEMCAD X 14.6.10(7417)

## Dipole Calibration for Head Tissue/Pin=250 mW, d=10mm/Zoom Scan (7x7x7)/Cube 0:

Measurement grid: dx=5mm, dy=5mm, dz=5mm

Reference Value = 110.9 V/m; Power Drift = -0.04 dB

Peak SAR (extrapolated) = 19.0 W/kg

**SAR(1 g) = 10.1 W/kg; SAR(10 g) = 5.27 W/kg**

Maximum value of SAR (measured) = 15.7 W/kg

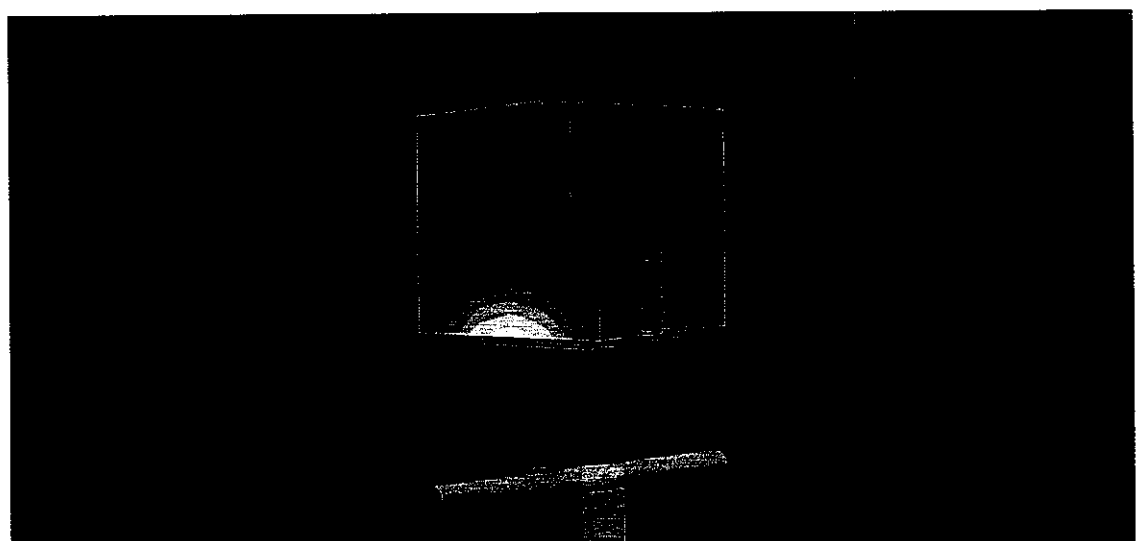

0 dB = 15.7 W/kg = 11.96 dBW/kg

# Impedance Measurement Plot for Head TSL

7 Nov 2017 09:01:33

CH1 S11 1 U FS 1: 51.154  $\Omega$  5.4141  $\Omega$  453.51 pF 1 900.000 000 MHz

\*  
Del  
CA  
Avg  
16  
H1d

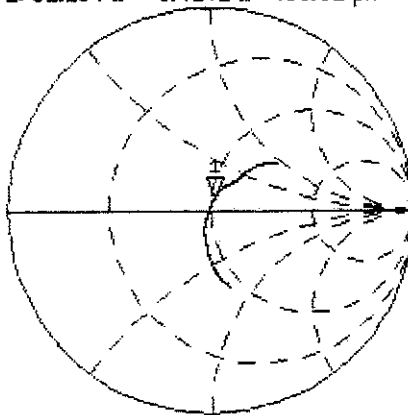

CH2 S11 LOG 5 dB/REF -20 dB 1:-25.250 dB 1 900.000 000 MHz

CA  
Avg  
16  
H1d

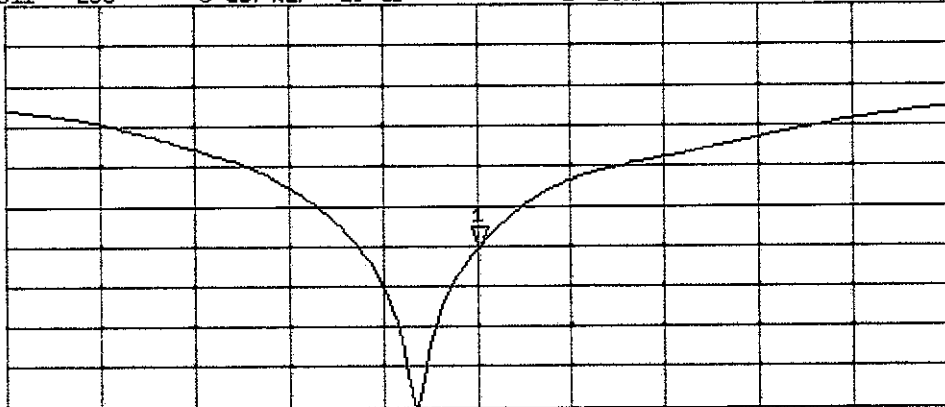

START 1 700.000 000 MHz

STOP 2 100.000 000 MHz



# DASY5 Validation Report for Body TSL

Date: 07.11.2017

Test Laboratory: SPEAG, Zurich, Switzerland

**DUT: Dipole 1900 MHz; Type: D1900V2; Serial: D1900V2 - SN:5d131**

Communication System: UID 0 - CW; Frequency: 1900 MHz

Medium parameters used:  $f = 1900$  MHz;  $\sigma = 1.46$  S/m;  $\epsilon_r = 54.1$ ;  $\rho = 1000$  kg/m<sup>3</sup>

Phantom section: Flat Section

Measurement Standard: DASY5 (IEEE/IEC/ANSI C63.19-2011)

DASY52 Configuration:

- Probe: EX3DV4 - SN7349; ConvF(8.2, 8.2, 8.2); Calibrated: 31.05.2017;
- Sensor-Surface: 1.4mm (Mechanical Surface Detection)
- Electronics: DAE4 Sn601; Calibrated: 26.10.2017
- Phantom: Flat Phantom 5.0 (back); Type: QD 000 P50 AA; Serial: 1002
- DASY52 52.10.0(1446); SEMCAD X 14.6.10(7417)

## Dipole Calibration for Body Tissue/Pin=250 mW, d=10mm/Zoom Scan (7x7x7)/Cube 0:

Measurement grid: dx=5mm, dy=5mm, dz=5mm

Reference Value = 105.1 V/m; Power Drift = -0.05 dB

Peak SAR (extrapolated) = 17.5 W/kg

**SAR(1 g) = 9.88 W/kg; SAR(10 g) = 5.27 W/kg**

Maximum value of SAR (measured) = 14.8 W/kg

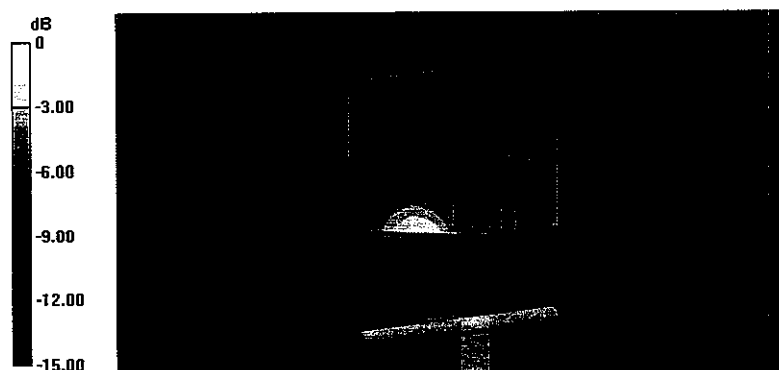

0 dB = 14.8 W/kg = 11.70 dBW/kg

# Impedance Measurement Plot for Body TSL

7 Nov 2017 09:00:39

CH1 S11 1 U FS 1: 46.480  $\Omega$  5.2832  $\Omega$  442.55 pF 1 900.000 000 MHz

\*  
De1  
C $\Delta$

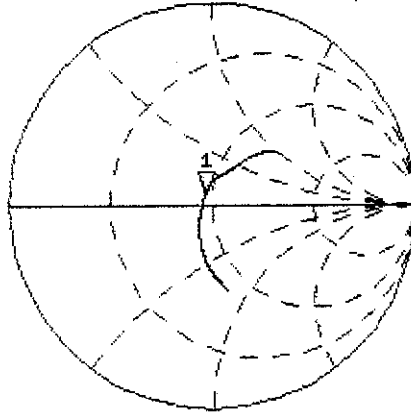

Avg  
15

H1d

CH2 S11 LOG 5 dB/REF -20 dB 1: -23.648 dB 1 900.000 000 MHz

C $\Delta$

Avg  
15

H1d

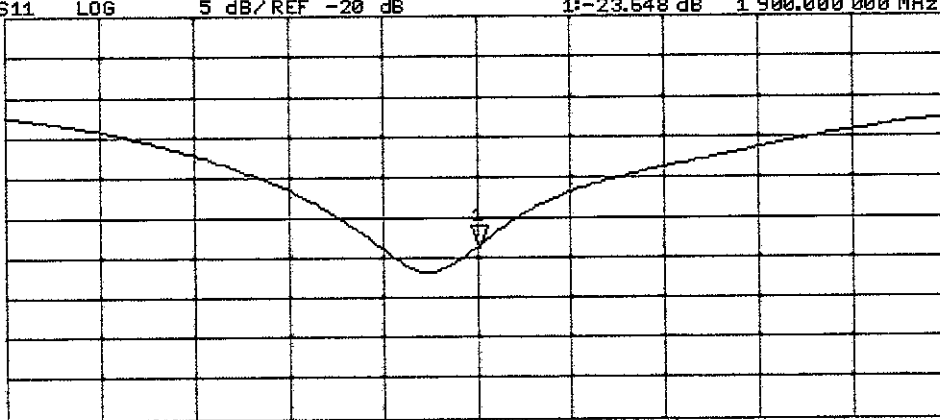

START 1 700.000 000 MHz

STOP 2 100.000 000 MHz

**Calibration Laboratory of  
Schmid & Partner  
Engineering AG**  
Zeughausstrasse 43, 8004 Zurich, Switzerland



**S** Schweizerischer Kalibrierdienst  
**C** Service suisse d'étalonnage  
**S** Servizio svizzero di taratura  
Swiss Calibration Service

Accredited by the Swiss Accreditation Service (SAS)  
The Swiss Accreditation Service is one of the signatories to the EA  
Multilateral Agreement for the recognition of calibration certificates

Accreditation No.: **SCS 0108**

Client **Element**

Certificate No: **ES3-3246\_Nov17**

**CALIBRATION CERTIFICATE**

Object **ES3DV3 - SN:3246**

Calibration procedure(s) **QA CAL-01.v9, QA CAL-12.v9, QA CAL-23.v5, QA CAL-25.v6  
Calibration procedure for dosimetric E-field probes**

Calibration date: **November 13, 2017**

This calibration certificate documents the traceability to national standards, which realize the physical units of measurements (SI).  
The measurements and the uncertainties with confidence probability are given on the following pages and are part of the certificate.

All calibrations have been conducted in the closed laboratory facility: environment temperature (22 ± 3)°C and humidity < 70%.

Calibration Equipment used (M&TE critical for calibration)

Primary Standards	ID	Cal Date (Certificate No.)	Scheduled Calibration
Power meter NRP	SN: 104778	04-Apr-17 (No. 217-02521/02522)	Apr-18
Power sensor NRP-Z91	SN: 103244	04-Apr-17 (No. 217-02521)	Apr-18
Power sensor NRP-Z91	SN: 103245	04-Apr-17 (No. 217-02525)	Apr-18
Reference 20 dB Attenuator	SN: S5277 (20x)	07-Apr-17 (No. 217-02528)	Apr-18
Reference Probe ES3DV2	SN: 3013	31-Dec-16 (No. ES3-3013_Dec16)	Dec-17
DAE4	SN: 660	7-Dec-16 (No. DAE4-660_Dec16)	Dec-17
Secondary Standards	ID	Check Date (in house)	Scheduled Check
Power meter E4419B	SN: GB41293874	06-Apr-16 (in house check Jun-16)	In house check: Jun-18
Power sensor E4412A	SN: MY41498087	06-Apr-16 (in house check Jun-16)	In house check: Jun-18
Power sensor E4412A	SN: 000110210	06-Apr-16 (in house check Jun-16)	In house check: Jun-18
RF generator HP 8648C	SN: US3642U01700	04-Aug-99 (in house check Jun-16)	In house check: Jun-18
Network Analyzer HP 8753E	SN: US37390585	18-Oct-01 (in house check Oct-17)	In house check: Oct-18

Calibrated by: **Claudio Leubler** (Name), **Laboratory Technician** (Function), [Signature] (Signature)

Approved by: **Katja Pokovic** (Name), **Technical Manager** (Function), [Signature] (Signature)

This calibration certificate shall not be reproduced except in full without written approval of the laboratory. Issued: November 15, 2017



Accredited by the Swiss Accreditation Service (SAS)  
The Swiss Accreditation Service is one of the signatories to the EA  
Multilateral Agreement for the recognition of calibration certificates

Accreditation No.: **SCS 0108**

**Glossary:**

TSL	tissue simulating liquid
NORM <sub>x,y,z</sub>	sensitivity in free space
ConvF	sensitivity in TSL / NORM <sub>x,y,z</sub>
DCP	diode compression point
CF	crest factor (1/duty_cycle) of the RF signal
A, B, C, D	modulation dependent linearization parameters
Polarization $\phi$	$\phi$ rotation around probe axis
Polarization $\vartheta$	$\vartheta$ rotation around an axis that is in the plane normal to probe axis (at measurement center), i.e., $\vartheta = 0$ is normal to probe axis
Connector Angle	information used in DASY system to align probe sensor X to the robot coordinate system

**Calibration is Performed According to the Following Standards:**

- a) IEEE Std 1528-2013, "IEEE Recommended Practice for Determining the Peak Spatial-Averaged Specific Absorption Rate (SAR) in the Human Head from Wireless Communications Devices: Measurement Techniques", June 2013
- b) IEC 62209-1, "Measurement procedure for the assessment of Specific Absorption Rate (SAR) from hand-held and body-mounted devices used next to the ear (frequency range of 300 MHz to 6 GHz)", July 2016
- c) IEC 62209-2, "Procedure to determine the Specific Absorption Rate (SAR) for wireless communication devices used in close proximity to the human body (frequency range of 30 MHz to 6 GHz)", March 2010
- d) KDB 865664, "SAR Measurement Requirements for 100 MHz to 6 GHz"

**Methods Applied and Interpretation of Parameters:**

- **NORM<sub>x,y,z</sub>**: Assessed for E-field polarization  $\vartheta = 0$  ( $f \leq 900$  MHz in TEM-cell;  $f > 1800$  MHz: R22 waveguide). NORM<sub>x,y,z</sub> are only intermediate values, i.e., the uncertainties of NORM<sub>x,y,z</sub> does not affect the E<sup>2</sup>-field uncertainty inside TSL (see below ConvF).
- **NORM(f)<sub>x,y,z</sub> = NORM<sub>x,y,z</sub> \* frequency\_response** (see Frequency Response Chart). This linearization is implemented in DASY4 software versions later than 4.2. The uncertainty of the frequency response is included in the stated uncertainty of ConvF.
- **DCP<sub>x,y,z</sub>**: DCP are numerical linearization parameters assessed based on the data of power sweep with CW signal (no uncertainty required). DCP does not depend on frequency nor media.
- **PAR**: PAR is the Peak to Average Ratio that is not calibrated but determined based on the signal characteristics
- **A<sub>x,y,z</sub>; B<sub>x,y,z</sub>; C<sub>x,y,z</sub>; D<sub>x,y,z</sub>; VR<sub>x,y,z</sub>**: A, B, C, D are numerical linearization parameters assessed based on the data of power sweep for specific modulation signal. The parameters do not depend on frequency nor media. VR is the maximum calibration range expressed in RMS voltage across the diode.
- **ConvF and Boundary Effect Parameters**: Assessed in flat phantom using E-field (or Temperature Transfer Standard for  $f \leq 800$  MHz) and inside waveguide using analytical field distributions based on power measurements for  $f > 800$  MHz. The same setups are used for assessment of the parameters applied for boundary compensation (alpha, depth) of which typical uncertainty values are given. These parameters are used in DASY4 software to improve probe accuracy close to the boundary. The sensitivity in TSL corresponds to NORM<sub>x,y,z</sub> \* ConvF whereby the uncertainty corresponds to that given for ConvF. A frequency dependent ConvF is used in DASY version 4.4 and higher which allows extending the validity from  $\pm 50$  MHz to  $\pm 100$  MHz.
- **Spherical isotropy (3D deviation from isotropy)**: in a field of low gradients realized using a flat phantom exposed by a patch antenna.
- **Sensor Offset**: The sensor offset corresponds to the offset of virtual measurement center from the probe tip (on probe axis). No tolerance required.
- **Connector Angle**: The angle is assessed using the information gained by determining the NORM<sub>x</sub> (no uncertainty required).

# Probe ES3DV3

## SN:3246

Manufactured: May 5, 2009  
Calibrated: November 13, 2017

**Calibrated for DASY/EASY Systems**  
(Note: non-compatible with DASY2 system!)

# DASY/EASY - Parameters of Probe: ES3DV3 - SN:3246

## Basic Calibration Parameters

	Sensor X	Sensor Y	Sensor Z	Unc (k=2)
Norm ( $\mu\text{V}/(\text{V}/\text{m})^2$ ) <sup>A</sup>	1.37	1.02	1.20	$\pm 10.1\%$
DCP (mV) <sup>B</sup>	100.0	99.9	100.2	

## Modulation Calibration Parameters

UID	Communication System Name		A	B	C	D	VR	Unc <sup>E</sup>
			dB	dB/ $\mu\text{V}$		dB	mV	(k=2)
0	CW	X	0.0	0.0	1.0	0.00	191.6	$\pm 3.5\%$
		Y	0.0	0.0	1.0		176.8	
		Z	0.0	0.0	1.0		198.6	

The reported uncertainty of measurement is stated as the standard uncertainty of measurement multiplied by the coverage factor k=2, which for a normal distribution corresponds to a coverage probability of approximately 95%.

<sup>A</sup> The uncertainties of Norm X,Y,Z do not affect the E<sup>2</sup>-field uncertainty inside TSL (see Pages 5 and 6).  
<sup>B</sup> Numerical linearization parameter: uncertainty not required.  
<sup>E</sup> Uncertainty is determined using the max. deviation from linear response applying rectangular distribution and is expressed for the square of the field value.

# DASY/EASY - Parameters of Probe: ES3DV3 - SN:3246

## Calibration Parameter Determined in Head Tissue Simulating Media

f (MHz) <sup>C</sup>	Relative Permittivity <sup>F</sup>	Conductivity (S/m) <sup>F</sup>	ConvF X	ConvF Y	ConvF Z	Alpha <sup>G</sup>	Depth <sup>G</sup> (mm)	Unc (k=2)
750	41.9	0.89	6.48	6.48	6.48	0.71	1.30	± 12.0 %
835	41.5	0.90	6.33	6.33	6.33	0.80	1.15	± 12.0 %
900	41.5	0.97	6.17	6.17	6.17	0.38	1.66	± 12.0 %
1750	40.1	1.37	5.44	5.44	5.44	0.46	1.50	± 12.0 %
1900	40.0	1.40	5.23	5.23	5.23	0.80	1.20	± 12.0 %

<sup>C</sup> Frequency validity above 300 MHz of ± 100 MHz only applies for DASY v4.4 and higher (see Page 2), else it is restricted to ± 50 MHz. The uncertainty is the RSS of the ConvF uncertainty at calibration frequency and the uncertainty for the indicated frequency band. Frequency validity below 300 MHz is ± 10, 25, 40, 50 and 70 MHz for ConvF assessments at 30, 64, 128, 150 and 220 MHz respectively. Above 5 GHz frequency validity can be extended to ± 110 MHz.

<sup>F</sup> At frequencies below 3 GHz, the validity of tissue parameters ( $\epsilon$  and  $\sigma$ ) can be relaxed to ± 10% if liquid compensation formula is applied to measured SAR values. At frequencies above 3 GHz, the validity of tissue parameters ( $\epsilon$  and  $\sigma$ ) is restricted to ± 5%. The uncertainty is the RSS of the ConvF uncertainty for indicated target tissue parameters.

<sup>G</sup> Alpha/Depth are determined during calibration. SPEAG warrants that the remaining deviation due to the boundary effect after compensation is always less than ± 1% for frequencies below 3 GHz and below ± 2% for frequencies between 3-6 GHz at any distance larger than half the probe tip diameter from the boundary.

## DASY/EASY - Parameters of Probe: ES3DV3 - SN:3246

### Calibration Parameter Determined in Body Tissue Simulating Media

f (MHz) <sup>C</sup>	Relative Permittivity <sup>F</sup>	Conductivity (S/m) <sup>F</sup>	ConvF X	ConvF Y	ConvF Z	Alpha <sup>G</sup>	Depth <sup>G</sup> (mm)	Unc (k=2)
450	56.7	0.94	7.44	7.44	7.44	0.13	1.90	± 13.3 %
750	55.5	0.96	6.54	6.54	6.54	0.54	1.41	± 12.0 %
835	55.2	0.97	6.31	6.31	6.31	0.79	1.19	± 12.0 %
900	55.0	1.05	6.27	6.27	6.27	0.80	1.11	± 12.0 %
1750	53.4	1.49	5.12	5.12	5.12	0.67	1.32	± 12.0 %
1900	53.3	1.52	4.88	4.88	4.88	0.40	1.78	± 12.0 %

<sup>C</sup> Frequency validity above 300 MHz of ± 100 MHz only applies for DASY v4.4 and higher (see Page 2), else it is restricted to ± 50 MHz. The uncertainty is the RSS of the ConvF uncertainty at calibration frequency and the uncertainty for the indicated frequency band. Frequency validity below 300 MHz is ± 10, 25, 40, 50 and 70 MHz for ConvF assessments at 30, 64, 128, 150 and 220 MHz respectively. Above 5 GHz frequency validity can be extended to ± 110 MHz.

<sup>F</sup> At frequencies below 3 GHz, the validity of tissue parameters ( $\epsilon$  and  $\sigma$ ) can be relaxed to ± 10% if liquid compensation formula is applied to measured SAR values. At frequencies above 3 GHz, the validity of tissue parameters ( $\epsilon$  and  $\sigma$ ) is restricted to ± 5%. The uncertainty is the RSS of the ConvF uncertainty for indicated target tissue parameters.

<sup>G</sup> Alpha/Depth are determined during calibration. SPEAG warrants that the remaining deviation due to the boundary effect after compensation is always less than ± 1% for frequencies below 3 GHz and below ± 2% for frequencies between 3-6 GHz at any distance larger than half the probe tip diameter from the boundary.



# Frequency Response of E-Field

(TEM-Cell:ifi110 EXX, Waveguide: R22)

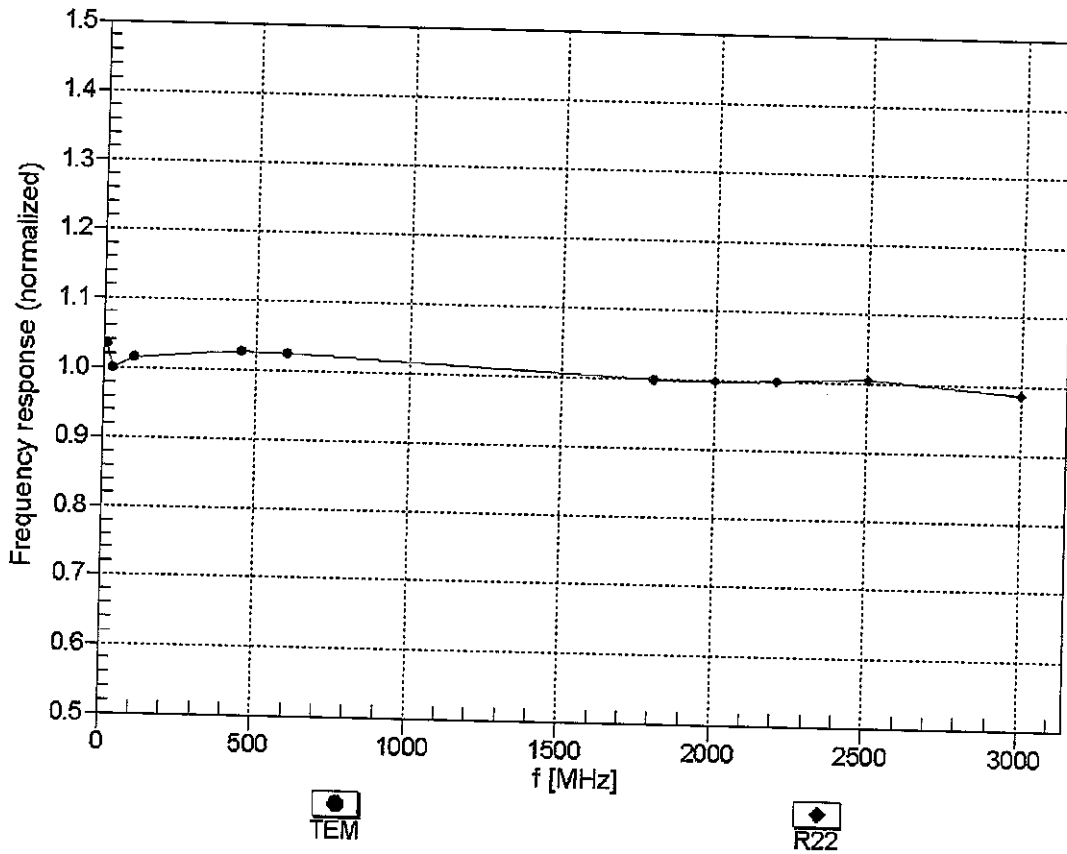

Uncertainty of Frequency Response of E-field:  $\pm 6.3\%$  (k=2)

### Receiving Pattern ( $\phi$ ), $\theta = 0^\circ$

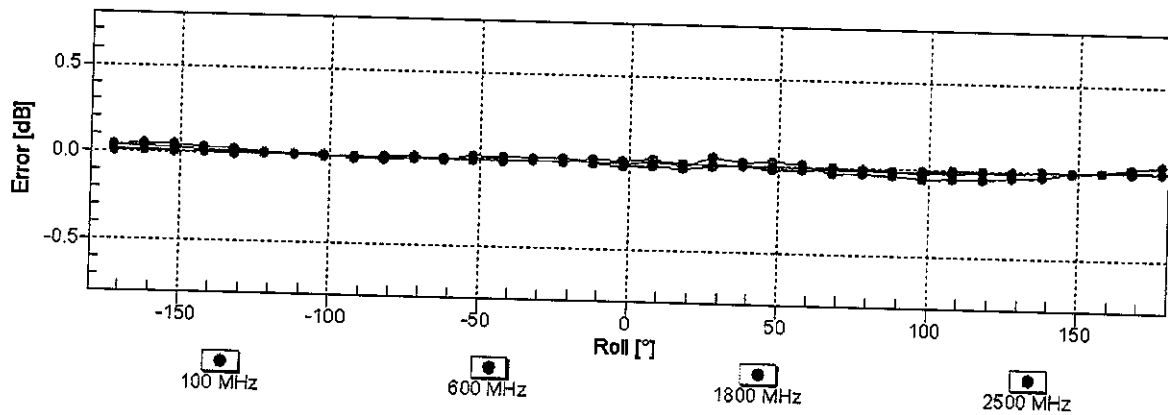
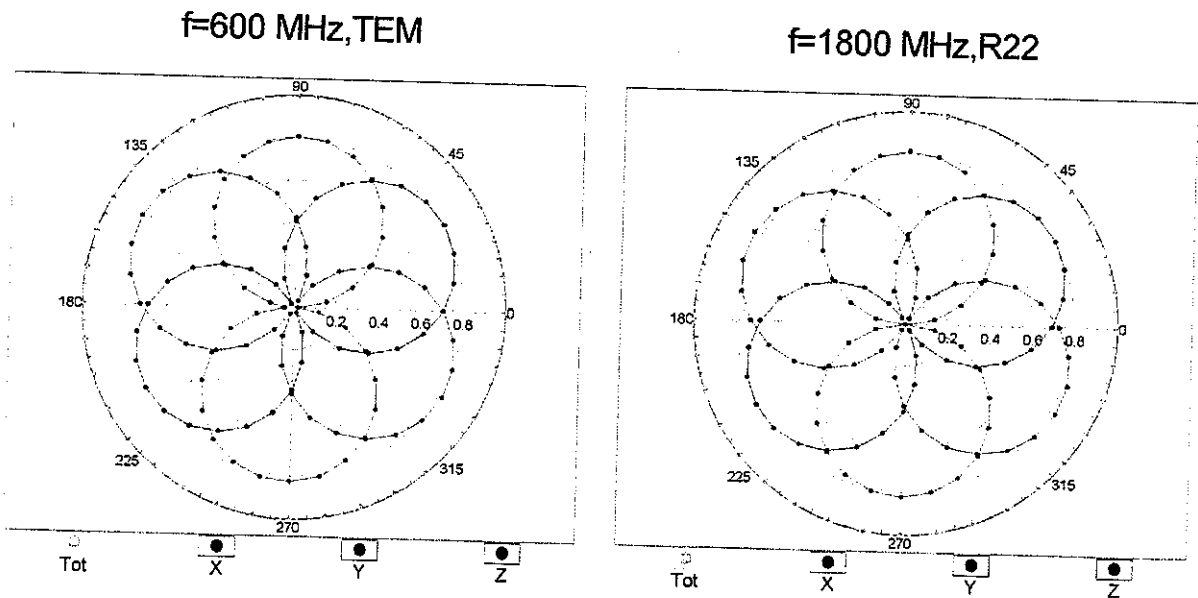

Uncertainty of Axial Isotropy Assessment:  $\pm 0.5\%$  ( $k=2$ )

### Dynamic Range $f(SAR_{head})$ (TEM cell , $f_{eval}= 1900$ MHz)

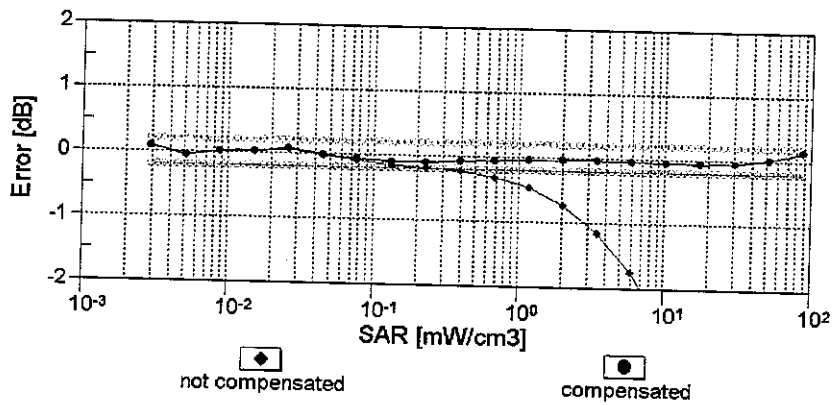
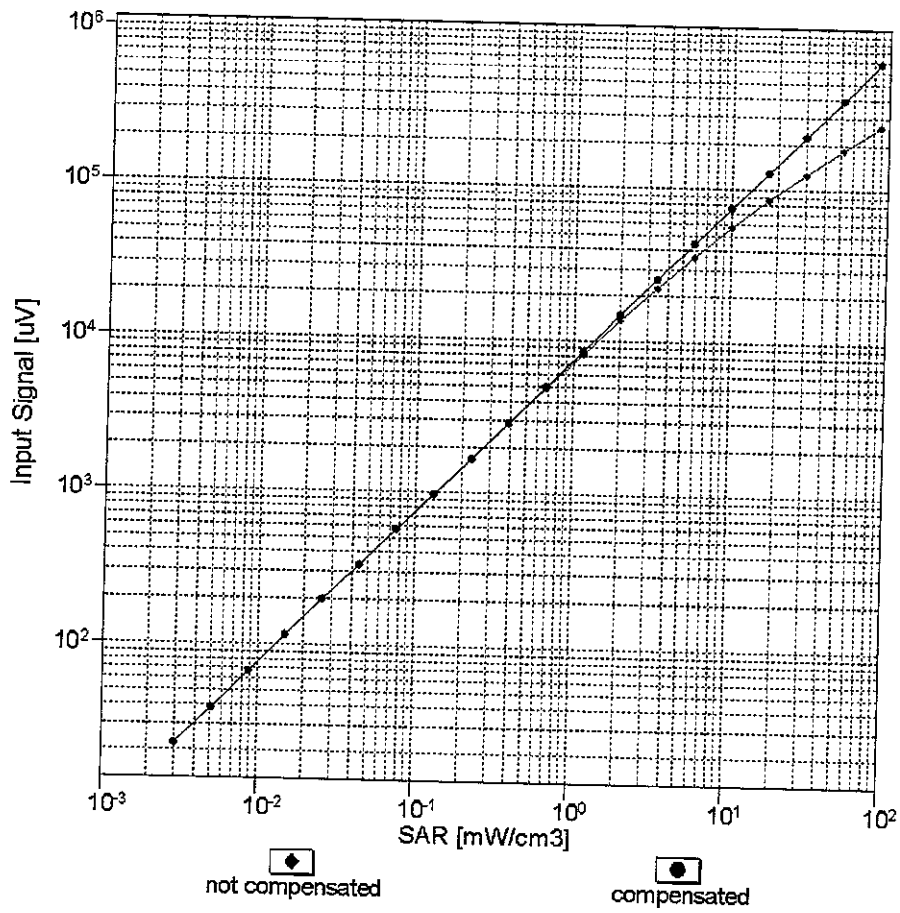

Uncertainty of Linearity Assessment:  $\pm 0.6\%$  (k=2)

# Conversion Factor Assessment

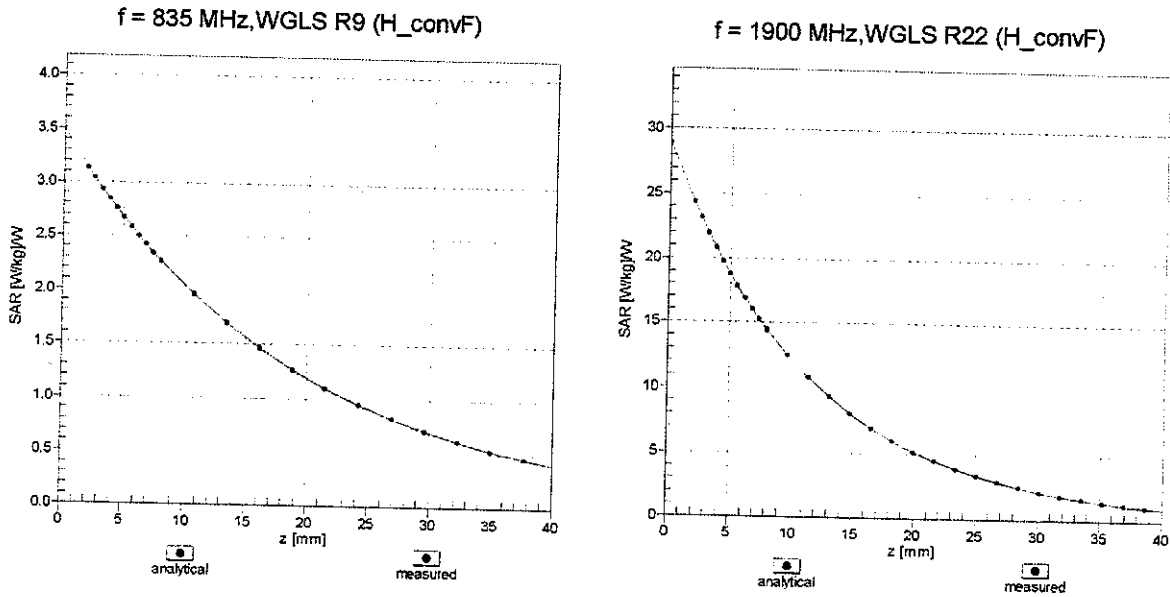

## Deviation from Isotropy in Liquid Error ( $\phi, \vartheta$ ), f = 900 MHz

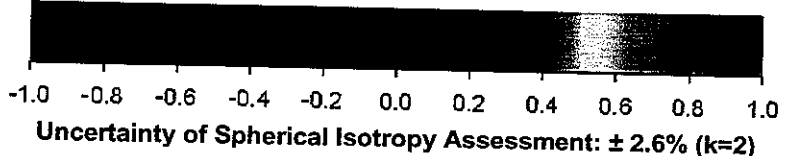
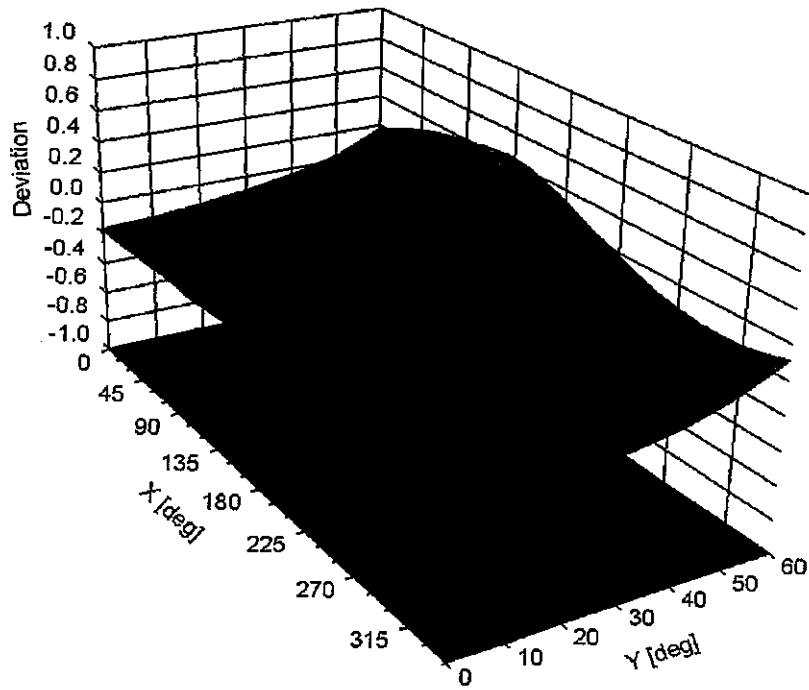

## DASY/EASY - Parameters of Probe: ES3DV3 - SN:3246

### Other Probe Parameters

Sensor Arrangement	Triangular
Connector Angle (°)	67.9
Mechanical Surface Detection Mode	enabled
Optical Surface Detection Mode	disabled
Probe Overall Length	337 mm
Probe Body Diameter	10 mm
Tip Length	10 mm
Tip Diameter	4 mm
Probe Tip to Sensor X Calibration Point	2 mm
Probe Tip to Sensor Y Calibration Point	2 mm
Probe Tip to Sensor Z Calibration Point	2 mm
Recommended Measurement Distance from Surface	3 mm