



TEST REPORT

No. 2014EMC0062

For

Client : Quectel Wireless Solutions Co. Ltd

Production : UMTS/HSDPA module

Model Name : UC15 Mini PCIe

Hardware Version: R1.0

Software Version: UC15AQR02A01E1G

FCC ID: XMR201404UC15M

Issued date: 2014-11-19

Note:

The test results in this test report relate only to the devices specified in this report. This report shall not be reproduced except in full without the written approval of ECIT Shanghai.

Test Laboratory:

ECIT Shanghai, East China Institute of Telecommunications

Add: 7F, G Area, No.668, Beijing East Road, Huangpu District, Shanghai, P. R. China

Tel: (+86)-021-63843300, E-Mail: welcome@ecit.org.cn



CONTENTS

1. TEST LABORATORY	3
1.1. TESTING LOCATION	3
1.2. TESTING ENVIRONMENT	3
1.3. PROJECT DATA	3
1.4. SIGNATURE	3
2. CLIENT INFORMATION	4
2.1. APPLICANT INFORMATION	4
2.2. MANUFACTURER INFORMATION	4
3. EQUIPMENT UNDER TEST (EUT) AND ANCILLARY EQUIPMENT (AE)	5
3.1. ABOUT EUT	5
3.2. INTERNAL IDENTIFICATION OF AE USED DURING THE TEST	5
4. REFERENCE DOCUMENTS.....	6
4.1. REFERENCE DOCUMENTS FOR TESTING	6
5. TEST RESULTS.....	7
5.1. SUMMARY OF TEST RESULTS.....	7
5.2. STATEMENTS.....	7
6. TEST EQUIPMENTS UTILIZED.....	8
6.1 RADIATED EMISSION EQUIPMENTS LIST	8
6.1 CE EQUIPMENTS LIST.....	8
7. SYSTEM CONFIGURATION DURING TEST	9
7.1 TEST MODE.....	9
7.2 CONNECTION DIAGRAM OF TEST SYSTEM.....	9
8. MEASUREMENT RESULTS	10
8.1 RADIATED EMISSION 30MHZ-12.75GHZ	10
8.2 CONDUCTED EMISSION.....	14

1. Test Laboratory

1.1. Testing Location

Company Name:	ECIT Shanghai, East China Institute of Telecommunications
Address:	7F, G Area, No. 668, Beijing East Road, Huangpu District, Shanghai, P. R. China
Postal Code:	200001
Telephone:	(+86)-021-63843300
Fax:	(+86)-021-63843301
FCC registration No:	489729

1.2. Testing Environment

Normal Temperature:	15-35°C
Relative Humidity:	30-60%

1.3. Project data

Project Leader:	Gong Yujuan
Testing Start Date:	2014-11-04
Testing End Date:	2014-11-14

1.4. Signature

You Jinjun
(Prepared this test report)

Yu Naiping
(Reviewed this test report)

Zheng Zhongbin
Director of the laboratory
(Approved this test report)



2. Client Information

2.1. Applicant Information

Company Name: Quectel Wireless Solutions Co. Ltd
Address /Post: Room 501, Building 13, No.99 Tianzhou Road, Xuhui District,
Shanghai,China
Country: China
Telephone: +86-21-51086236

2.2. Manufacturer Information

Company Name: Quectel Wireless Solutions Co. Ltd
Address /Post: Room 501, Building 13, No.99 Tianzhou Road, Xuhui District,
Shanghai,China
Country: China
Telephone: +86-21-51086236

3. Equipment under Test (EUT) and Ancillary Equipment (AE)

3.1. About EUT

EUT Description	UMTS/HSDPA module
Model name	UC15 Mini PCIe
Serial Number or IMEI	863835020007923
GSM Frequency Band	GSM850/GSM900/GSM1800/GSM1900
UMTS Frequency Band	WCDMA band II/WCDMA band V
HW Version	R1.0
SW Version	UC15AQR02A01E1G

3.2. Internal Identification of AE used during the test

AE ID*	Description	Model	SN
AE1	Adapter	P-050B	NA
AE2	Battery	H15287	EB09F000000E0000375T
AE3	Earphone	NA	NA
AE4	Data Cable	NA	NA
AE5	Desktop PC	OptiPlex 790 DT	X8RP1 A01 APCC
AE6	Notebook PC	ThinkPad T420i	P1-5LEBD
AE7	LAN Cable	NA	NA
AE8	VGA Cable	NA	NA
AE9	RS232 Cable	NA	NA
AE10	Keyboard	KB212-B	CN-0Y88XT-65890-12I-005Q-A00
AE11	Mouse	MS111-P	CN-011D3V-71581-19J-1A64

*AE ID: is used to identify the test sample in the lab internally.



4. Reference Documents

4.1. Reference Documents for testing

The following documents listed in this section are referred for testing.

Reference	Title	Version
FCC Part 15, Subpart B	Radio frequency devices	10-1-10 Edition
ANSI C63.4	Method of Measurement of Radio-Noise Emissions from Low-Voltage Electrical and Electronic Equipment in the Range of 9 kHz to 40 GHz	2009

5. Test Results

5.1. Summary of Test Results

Items	Test List	Clause in FCC rules	Verdict
1	Radiated Emission	15.109(a)	Pass
2	Conducted Emission	15.107(a)	Pass

5.2. Statements

The UC15 Mini PCIe supporting GSM850/GSM900/GSM1800/GSM1900 and WCDMA band II/V, manufactured by Quectel Wireless Solutions Co. Ltd is a new product for testing. ECIT only performed test cases which identified with Pass/Fail/Inc result in section 5.1.

ECIT has verified that the compliance of the tested device specified in section 3 of this test report is successfully evaluated according to the procedure and test methods as defined in type certification requirement listed in section 4 of this test report.

6. Test Equipments Utilized

6.1 Radiated Emission Equipments list

No	Name	Type	Series Number	Producer	Cal. Date	Cal. Period
1	Universal Radio Communication	CMU200	123102	R&S	2014-07-07	1 Year
2	Test Receiver	ESU40	100307	R&S	2014-07-25	1 Year
3	Trilog Antenna	VULB9163	19-162515	Schwarzbeck	2014-05-06	3 Year
4	Double Ridged Guide Antenna	ETS3117	135885	ETS	2014-11-05	3 Year

6.1 CE Equipments list

No	Name	Type	Series Number	Producer	Cal. Date	Cal. Period
1	Universal Radio Communication	CMU200	123124	R&S	2014-07-07	1 Year
2	Test Receiver	ESCI	101235	R&S	2014-07-07	1 Year
3	2-Line V-Network	ENV216	101380	R&S	2014-07-25	1 Year

7. System Configuration during Test

7.1 Test Mode

Test Item	Function Type
AC Conducted Emission	Mode 1: Idle + Earphone + USB cable (Data Link with PC) <Figure 1> Mode 2: Idle + Earphone + Adapter charging <Figure 2>
Radiated Emission	Mode 1: Idle + Earphone + USB cable (Data Link with PC) <Figure 1> Mode 2: Idle + Earphone + Adapter charging <Figure 2>
Remark: 1. All test modes are performed, only the worst cases test data are recorded in this report. 2. Data Link with PC means data application transferred mode between EUT and PC.	

7.2 Connection Diagram of Test System

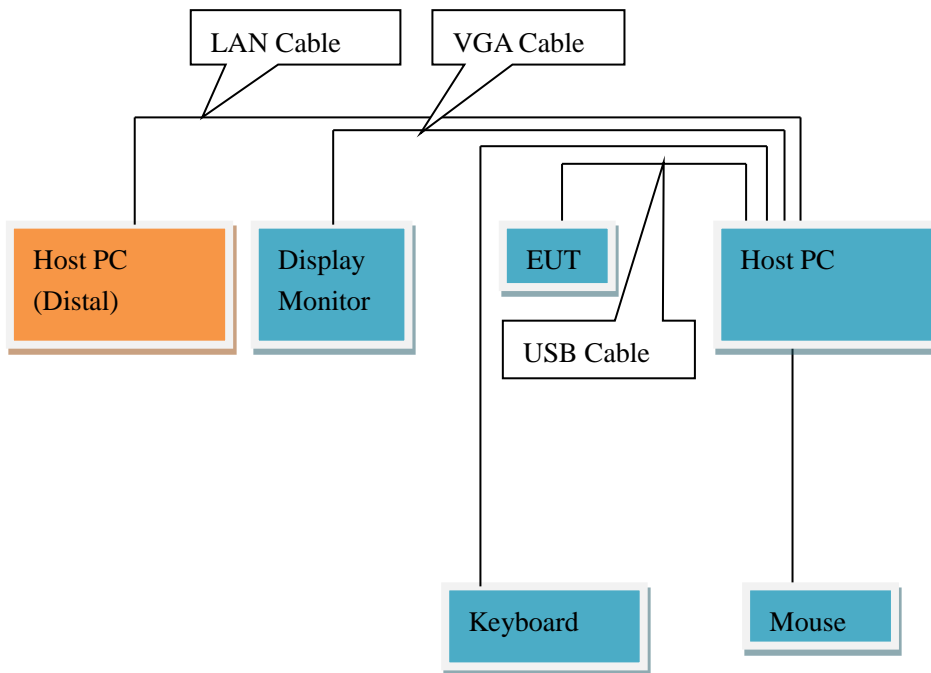

<Figure 1>



<Figure 2>

8. Measurement Results

Only the worst test result was shown in this report.

8.1 Radiated Emission 30MHz-12.75GHz

Method of Measurement

For 30-1000MHz, the EUT was placed on the top of a rotating 0.8-m table above the ground at a semi-anechoic chamber. The distance between the EUT and the received antenna was 3 meters. The table was rotated 360 degree and the received antenna mounted on a variable-height antenna tower was varied from 1m to 4m to find the maximum value of the field strength. Both horizontal and vertical polarizations of the antenna were set during the measurement. Tested in accordance with the procedures of ANSI C63.4-2009, section 8.3.

For 1000-12750MHz, The maximal emission value was acquired by adjusting the antenna height, The table was rotated 360 degree to determine the maximum value of the field strength. Both horizontal and vertical polarizations of the antenna were set during the measurement.

Limits for Radiated Emission at a measuring distance of 3m

Frequency Range (MHz)	Quasi-Peak (dBuV/m)
30-88	40
88-216	43.5
216-960	46
Above 960	54

Frequency Range (MHz)	Peak (dBuV/m)	Average (dBuV/m)
Above 1000	74	54

Test conditions

Frequency Range (MHz)	RBW/VBW	Sweep Time (s)
30-1000	120KHz/300KHz	5
1000-12750	1MHz/1MHz	10

Uncertainty Measurement

The measurement uncertainty is 3.92dB (k=1.96).

Test Results

Mode 1: Idle + Earphone + USB cable (Data Link with PC)

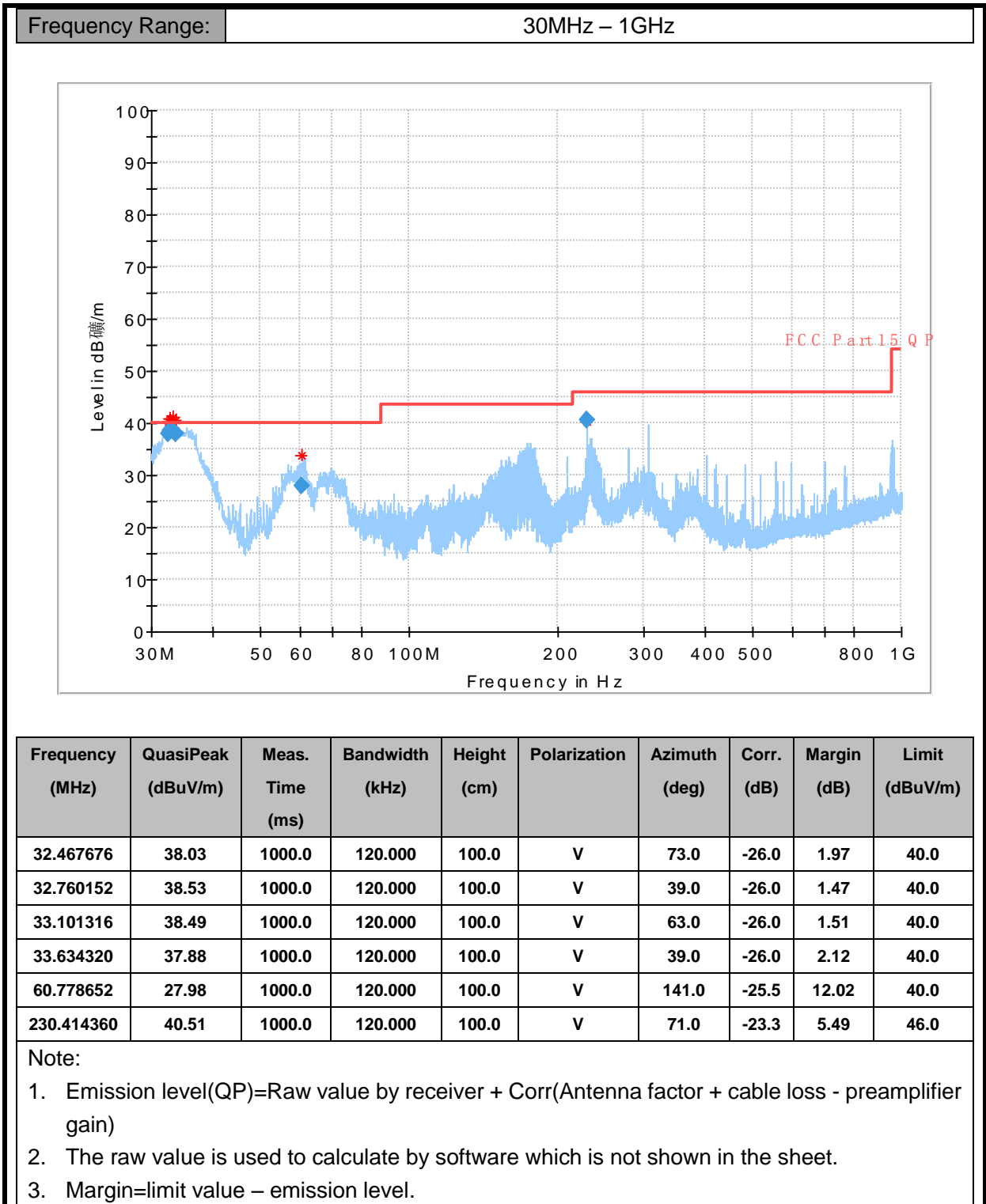

Mode 1: Idle + Earphone + USB cable (Data Link with PC)

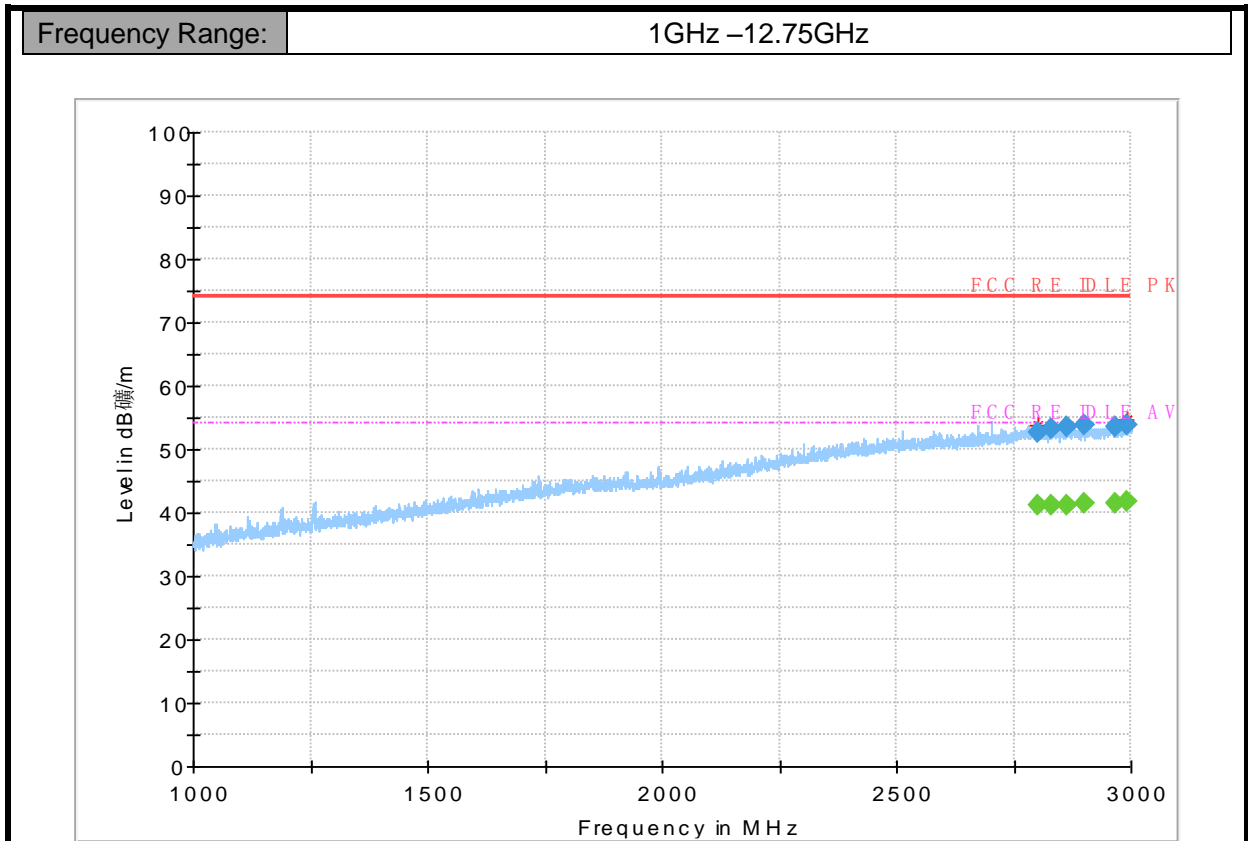

Final Result 1

Frequency (MHz)	MaxPeak (dBuV/m)	Meas. Time (ms)	Bandwidth (kHz)	Height (cm)	Polarization	Azimuth (deg)	Corr. (dB)	Margin (dB)	Limit (dBuV/m)
2799.6892	52.72	50.0	1000.000	155.0	H	7	10	21.28	74.0
2828.586	53.35	50.0	1000.000	155.0	V	7	10.1	20.65	74.0
2863.0384	53.6	50.0	1000.000	155.0	H	140	10.3	20.4	74.0
2900.7964	53.96	50.0	1000.000	155.0	H	110	10.5	20.04	74.0
2965.1156	53.53	50.0	1000.000	155.0	H	294	10.5	20.47	74.0
2991.5216	53.89	50.0	1000.000	155.0	V	3	10.9	20.11	74.0

Final Result 2

Frequency (MHz)	Average (dBuV/m)	Meas. Time (ms)	Bandwidth (kHz)	Height (cm)	Polarization	Azimuth (deg)	Corr. (dB)	Margin (dB)	Limit (dBuV/m)
2799.6892	41.19	50.0	1000.000	155.0	H	7	10	12.81	54.0
2828.586	41.21	50.0	1000.000	155.0	V	-7	10.1	12.79	54.0
2863.0384	41.31	50.0	1000.000	155.0	H	140	10.3	12.69	54.0
2900.7964	41.43	50.0	1000.000	155.0	H	110	10.5	12.57	54.0
2965.1156	41.49	50.0	1000.000	155.0	H	294	10.5	12.51	54.0
2991.5216	41.82	50.0	1000.000	155.0	V	-3	10.9	12.18	54.0

Note:

1. Emission level(peak or average)=Raw value by receiver + Corr(Antenna factor+ cable loss -

preamplifier gain)

2. The raw value is used to calculate by software which is not shown in the sheet.

Margin=limit value – emission level.

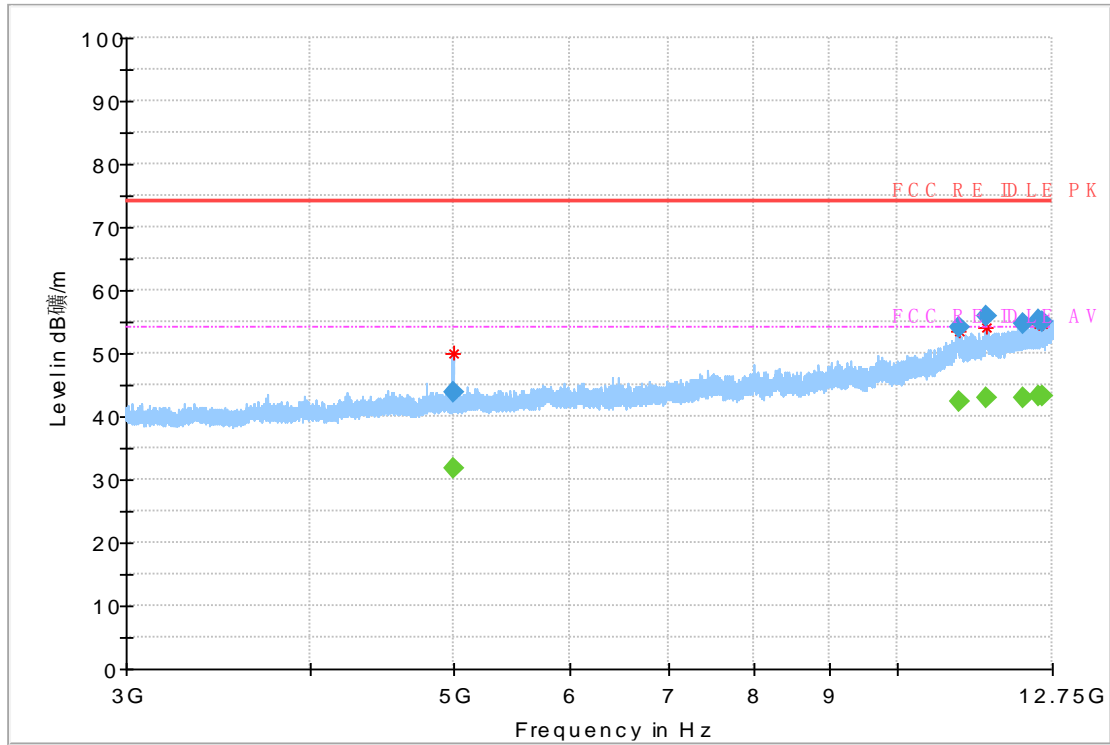

Final Result 1

Frequency (MHz)	MaxPeak (dBuV/m)	Meas. Time	Bandwidth (kHz)	Height (cm)	Polarization	Azimuth (deg)	Corr. (dB)	Margin (dB)	Limit (dBuV/m)
4999.1956	43.87	50.0	1000.000	155.0	V	206	11.0	30.13	74.0
11015.945	54.12	50.0	1000.000	155.0	V	230	14.3	19.88	74.0
11491.3195	56	50.0	1000.000	155.0	H	28	14.8	18	74.0
12175.7984	54.71	50.0	1000.000	155.0	V	0	14.8	19.29	74.0
12465.8743	55.32	50.0	1000.000	155.0	V	274	15.3	18.68	74.0
12555.9527	54.93	50.0	1000.000	155.0	V	238	15.5	19.07	74.0

Final Result 2

Frequency (MHz)	Average (dBuV/m)	Meas. Time	Bandwidth (kHz)	Height (cm)	Polarization	Azimuth (deg)	Corr. (dB)	Margin (dB)	Limit (dBuV/m)
4999.1956	31.82	50.0	1000.000	155.0	V	206	11.0	22.18	54.0
11015.945	42.29	50.0	1000.000	155.0	V	230	14.3	11.71	54.0
11491.3195	42.98	50.0	1000.000	155.0	H	28	14.8	11.02	54.0
12175.7984	42.89	50.0	1000.000	155.0	V	0	14.8	11.11	54.0
12465.8743	43.19	50.0	1000.000	155.0	V	274	15.3	10.81	54.0
12555.9527	43.33	50.0	1000.000	155.0	V	238	115.5	10.67	54.0

Note:

1. Emission level(peak or average)=Raw value by receiver + Corr(Antenna factor+ cable loss - preamplifier gain)
2. The raw value is used to calculate by software which is not shown in the sheet.

Margin=limit value – emission level.

8.2 Conducted Emission**Method of Measurement**

For equipment that is designed to be connected to the public utility (AC) power line, the radio frequency voltage that is conducted back onto the AC power line on any frequency or frequencies with the band 150 kHz to 30MHz shall not exceed the limits. Both lines of the power mains connected to the EUT were checked for maximum conducted interference. Tested in accordance with the procedures of ANSI C63.4-2009, section 7.3

Limit of Conducted Emission

Frequency Range (MHz)	Conducted Limit (dBuV)	
	Quasi-peak	Average
0.15-0.5	66 to 56*	56 to 46*
0.5-5	56	46
5-30	60	50

*Decreases with the logarithm of the frequency

Test Condition in Charging Mode

Voltage (V)	Frequency (Hz)	RBW	Sweep Time (s)
120	60	9 KHz	1

Uncertainty Measurement

The measurement uncertainty is 2.69dB (k=1.96).

Test Results

Mode 1: Idle + Earphone + USB cable (Data Link with PC)

Frequency Range:

150kHz – 30MHz

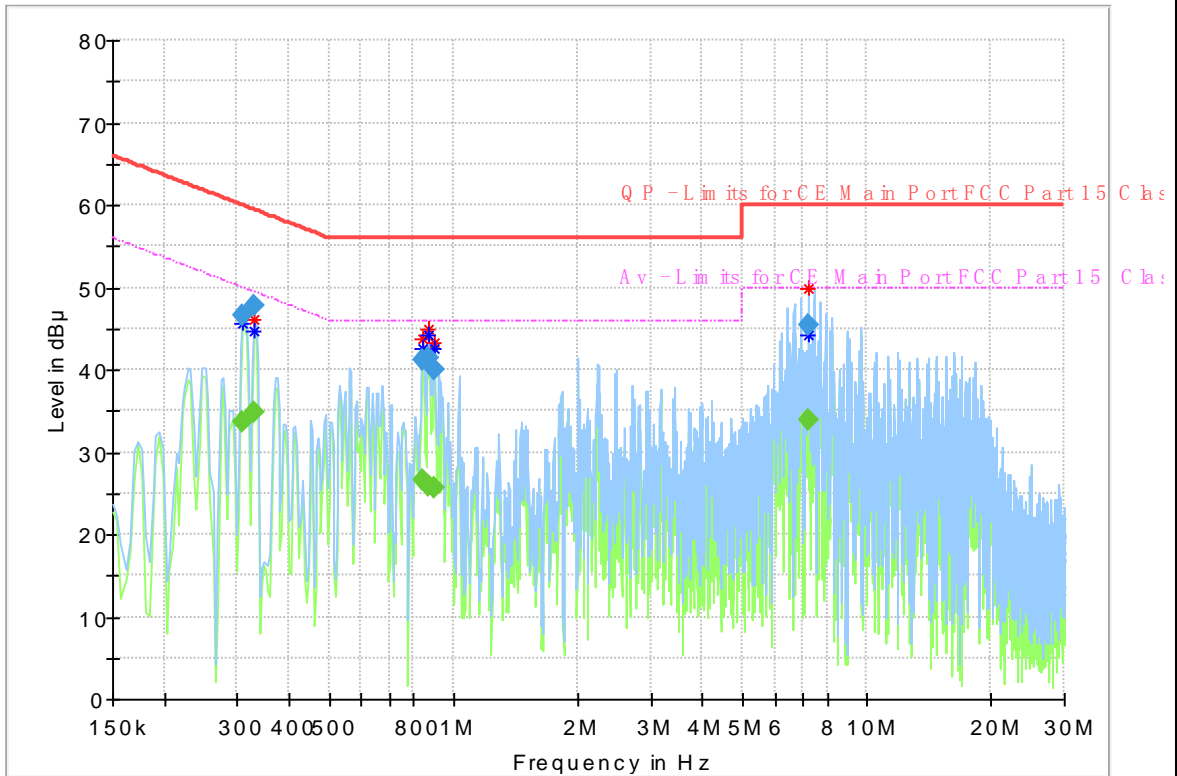

Frequency (MHz)	QuasiPeak (dB μ V)	Meas. Time	Bandwidth (kHz)	Filter	Line	Corr. (dB)	Margin (dB)	Limit (dB μ V)
0.310444	46.68	1000.0	9.000	On	L1	9.8	13.28	59.96
0.3291	47.87	1000.0	9.000	On	L1	9.8	11.6	59.47
0.840281	41.22	1000.0	9.000	On	L1	9.8	14.78	56
0.870131	41.35	1000.0	9.000	On	L1	9.8	14.65	56
0.899981	39.97	1000.0	9.000	On	L1	9.8	16.03	56
7.213256	45.43	1000.0	9.000	On	L1	9.8	14.57	60

Frequency (MHz)	Average (dB μ V)	Meas. Time	Bandwidth (kHz)	Filter	Line	Corr. (dB)	Margin (dB)	Limit (dB μ V)
0.310444	33.53	1000.0	9.000	On	L1	9.8	16.43	49.96
0.3291	34.81	1000.0	9.000	On	N	9.8	14.66	49.47
0.840281	26.62	1000.0	9.000	On	N	9.8	19.38	46
0.870131	25.92	1000.0	9.000	On	N	9.8	20.08	46
0.899981	25.57	1000.0	9.000	On	N	9.8	20.43	46
7.213256	33.92	1000.0	9.000	On	N	9.8	16.08	50

Note:

1. Emission level(quasi-peak or Average peak)=Raw value by receiver + Corr(Insertion loss+cable loss)



2. The raw value is used to calculate by software which is not shown in the sheet.
3. Margin=limit value – emission level.

*****End the Report*****