



# PRODUCT MANUAL FOR TORNADO X & TORNADO XR

FCC ID: XMK-MMXTRNXB002

Issue 1 – June 2021

*This document contains proprietary information and must not be provided or copied to third parties without express permission from Mimomax Wireless Ltd*

**mimomax**

**Mimomax Wireless Ltd**  
Issue 1 – June 2021  
Product Manual for Tornado X and Tornado XR  
Copyright © 2021 Mimomax Wireless Ltd.

#### **Disclaimer**

*While precaution has been taken in the preparation of this literature and it is believed to be correct at the time of issue, Mimomax Wireless Ltd assumes no liability for errors or omissions or for any damages resulting from the use of this information. Due to a policy of continuous technical improvement, the contents of this document and any specifications contained therein are subject to revision and may change without notice.*

## WARRANTY

**Mimomax Wireless Limited ("Mimomax")** warrants for a period of 12 months from the date of delivery that its hardware items ("**Equipment**") will be free from defects due to defective design, workmanship or materials subject the conditions below ("**Warranty**").

### CONDITIONS OF WARRANTY

This Warranty is strictly subject to the following conditions:

- (a) Mimomax will not be liable for breach of Warranty unless the customer (i) notifies Mimomax of the alleged defects within 30 days after the defect would have become reasonably apparent, and (ii) promptly returns the Equipment carriage paid with a full written report on the alleged defects.
- (b) The Warranty is not transferable.
- (c) Mimomax's liability under this Warranty is dependent on an assessment by Mimomax to determine and validate the defect in design, workmanship or materials.
- (d) The customer shall refund to Mimomax the cost to Mimomax of any replacement, repair or redelivery of any Equipment effected by Mimomax where the failure is not within the terms of this Warranty.
- (e) Mimomax does not guarantee that any service performed under this Warranty will be carried out within any particular timeframe.
- (f) To the fullest extent permitted by law, Mimomax's liability under this Warranty is limited to (at Mimomax's option) replacing or repairing the Equipment or the relevant part thereof without charge provided that its liability shall in no event exceed the purchase price of the Equipment or the relevant part thereof. Where Mimomax authorises the customer to undertake Warranty repairs, no reimbursement will be made in respect of labour.

### GENERAL EXCLUSIONS

Mimomax shall not be liable under this Warranty:

- (a) where the Equipment has not been stored, installed, maintained and used properly having regard in particular to Mimomax's and (if any) other agreed applicable specifications and instructions including (without limitation) in relation to the installation of engineering changes or enhancements;
- (b) where the Equipment has not been used in accordance with interference-free power, suitable environment (including but not limited to free from electronic or radio interference and pests) and correct maintenance of the Equipment;
- (c) for third party interference, fair wear and tear, abuse, damage or misuse, correction or repairs or modifications made other than by Mimomax or any repairs required due to events beyond the control of Mimomax;
- (d) for abnormal conditions (electrical, thermal, chemical or otherwise), including (without limitation) factors outside the operational parameters for the Equipment;
- (e) for any defect caused by or arising from use of any software not licensed or supplied by Mimomax, or otherwise caused by or arising from the customer's acts or omissions.

### LIMITATION OF LIABILITY

Except as set out in this Warranty and to the maximum extent permitted by law:

- (a) all warranties, conditions, liabilities and obligations with respect to any Mimomax product, software or services (including as to merchantability, description quality, or fitness for a specific purpose) are expressly excluded; and
- (b) Mimomax shall not be liable for any losses or damages (whether direct or indirect) including property damage or personal injury, consequential loss, economic loss or loss of profits or other economic advantage, however caused which may be suffered or incurred by the customer or any third person, or which may arise directly or indirectly out of or in respect of any Mimomax product, software or services or by reason of any act or omission on the part of Mimomax.

### CUSTOMER ACKNOWLEDGEMENT

The customer acknowledges that:

- (a) if the Consumer Guarantees Act 1993 ("**CGA**") applies, this Warranty shall be read subject to customer's rights under the CGA. Where the customer uses the Equipment for business purposes, the provisions of CGA, or any other relevant consumer protection legislation, shall not apply;
- (b) the Equipment is not designed or intended for use in on-line control of aircraft, air traffic, aircraft navigation or aircraft communications; intrinsically safe environments or in the design, construction, operation or maintenance of any nuclear facility. Mimomax disclaims any express or implied warranty of fitness for such uses. The customer will not use or resell Equipment for such purposes;
- (c) any software supplied by Mimomax cannot be tested in every possible permutation and accordingly Mimomax does not warrant that software supplied will be free of all defects or that its use will be uninterrupted.

# Table of Contents

1	Tornado X System Overview.....	9
1.1	Network Digital Links (NDL) .....	9
1.2	Multipoint Digital Links (MDL).....	10
1.3	Optimized Protection Variant (OPV).....	11
2	Safety Warnings.....	13
2.1	Modifications .....	13
2.2	Transmitter Antenna.....	13
2.2.1	Tornado X and Tornado XR 700MHz Transmitter Antenna.....	13
2.3	Safety Distance .....	13
2.3.1	Tornado X and Tornado XR 700MHz Safety Distance.....	13
2.4	FCC RF Exposure Statement.....	14
2.4.1	Tornado 700MHz FCC RF Exposure Statement .....	14
2.5	Electrical Safety Cable Screening .....	14
2.6	Mains Connection.....	15
2.7	FCC 15.19 Statement.....	15
2.8	FCC 15.105(b) Statement .....	15
3	Tornado Radio Unit Overview .....	16
3.1	Connectors.....	16
3.2	Digital Processing System.....	17
3.2.1	Power Supply .....	17
3.2.2	Central Processor Unit .....	17
3.2.3	FPGA .....	17
3.2.4	Receive Converters.....	18
3.2.5	Transmit Converters.....	18
3.2.6	Reference & Clock Synthesisers.....	18
3.2.7	Dual Ethernet .....	18
3.2.8	Dual Serial.....	18
3.2.9	GPIO .....	18
3.2.10	Alarm.....	18
3.2.11	Front Panel Leds.....	18
3.3	Receiver RF/IF Sections .....	19
3.3.1	Front End .....	19
3.3.2	Mixer and LO Buffer .....	19
3.3.3	IF and AGC Circuitry .....	19
3.3.4	Local Oscillator.....	19
3.4	Transmitter RF/IF Sections .....	19
3.4.1	Forward Signal Path.....	19
3.4.2	Feedback Signal Path .....	20
3.4.3	Local Oscillator.....	20
3.4.4	Internal Duplexer.....	20

4	Setting Up on the Bench .....	21
4.1	Testing the Network Setup .....	22
5	Configuration Control and Monitoring System (CCMS).....	24
6	Changing Operating Frequency and Power Calibration .....	25
6.1	Introduction .....	25
6.2	Equipment Required: Power Meter .....	25
6.3	Process Overview .....	25
6.4	CCMS Process.....	25
6.5	Power Calibration.....	27
6.5.1	Calibrating Tx (coarse step) .....	28
6.5.2	Calibrating Tx (fine step) .....	28
6.5.3	Complete Calibration of One Tx .....	29
6.5.4	Complete Both Transmitter Calibration .....	29
6.5.5	To Finish Power Calibration, click <i>Done</i> Calibration Fault.....	30
7	RSSI Calibration.....	31
7.1	RSSI Calibration.....	31
7.2	Reference Calibration.....	32
7.2.1	Equipment Required for Reference Calibration .....	32
7.2.2	How to Calibrate the Reference .....	32
8	Radio Reference Information .....	34
8.1	Mechanical Dimensions and Mounting.....	34
8.1.1	Dimensions .....	34
8.1.2	Mounting .....	35
8.2	Input and Output .....	40
8.2.1	Connectors.....	41
8.2.2	LED Behaviour .....	41
8.2.3	Essential Power Requirements .....	42
	Electrical Characteristics .....	45
8.2.4	Interface Ports.....	47
8.2.5	RF Specification .....	49
8.3	Installation .....	53
8.4	Compliances .....	55
9	Document History.....	56

## Abbreviations And Acronyms

AC	Alternating Current
ACMA	Australian Communications and Media Authority
ADC	Analogue to Digital Converter
ADPCM	Adaptive Differential Pulse Code Modulation
AFC	Automatic Frequency Control
AGC	Automatic Gain Control
ANT	Antenna
BER	Bit Error Rate
BRU	Base Radio Unit
BW	Bandwidth
CAT	Category
CCMS	Configuration Control & Monitoring Software
CODECS	Coder Decoder
CPU	Central Processing Unit
CRC	Cyclic Redundancy Check
CSV	Comma Separated Value
DAC	Digital to Analogue Converter
DC	Direct Current
DFE	Decision-Feedback Equalizer
DIF	Digital Interface
DPLXR	Duplexer
DPS	Digital Processing System
DRU	Diversity Radio Unit
DSP	Digital Signal Processing
DTE	Data Terminal Equipment
EF	Express Forward
EMC	Electromagnetic Compatibility
ERM	Electromagnetic Compatibility and Radio Spectrum Matters
ESD	Electrostatic Sensitive Device
ETSI	European Telecommunications Standards Institute
FCC	Federal Communications Commission
FIFO	First In, First Out
FPGA	Field-Programmable Gate Array
FTP	File Transfer Protocol
GND	Ground
GPS	Global Positioning System
GRE	Generic Routing Encapsulation
HPF	High Pass Filter
HSSI	High Speed Serial Interface

HTML	Hyper-Text Mark-Up Language
IF	Intermediate Frequency
IO	Input Output
IP	Internet Protocol
ITU	International Telecommunication Union
LED	Light Emitting Diode
LNA	Low Noise Amplifier
LO	Local Oscillator
LPF	Low Pass Filter
LRU	Link Radio Unit
MAC	Media Access Control
MCAM	Mimomax Cognisant Adaptive Modulation
MDAP	Mimomax Data Acceleration Protocols
MDIX	Medium Dependent Interface Crossover
MDL	Multipoint Digital Link
MIB	Management Information Base
MIMO	Multi Input Multi Output
MRAP	Mimomax Routing Adaptation Protocols
NDL	Network Digital Link
NIB	Network Interface Board
NTP	Network Time Protocol
OPV	Optimised Protection Variant
OSI	Open System Interconnection
OSPF	Open Shortest Path First
OTAC	Over the Air Configuration
OTAP	Over the Air Programming
PA	Power Amplifier
PC	Personal Computer
PCB	Printed Circuit Board
PECL	Positive Emitter-Coupled Logic
PG	Pulse Shaper Gain
PIF	Power Interface
PIN	P-Type, Intrinsic, N-Type
PLL	Phase Locked Loop
PMR	Private Mobile Radio
PSU	Power Supply Unit
QAM	Quadrature Amplitude Modulation
QPSK	Quadrature Phase-Shift Keying
RF	Radio Frequency
RFI	Radio Frequency Interference
RRU	Remote Radio Unit
RSSI	Received Signal Strength Indication

RTP	Real-Time Protocol
RU	Radio Unit
RX	Receive
SCADA	Supervisory Control and Data Acquisition
SEPIC	Single Ended Primary Inductor Converter
SFE	Software Feature Enabler
SMB	Sub miniature Version B
SNMP	Simple Network Management Protocol
SPI	Serial Peripheral Interface
SS	Synchronous Serial
TCP	Transmission Control Protocol
TTR	Time to Repair
TX	Transmit
UART	Universal Asynchronous Receiver/Transmitter
UDP	User Datagram Protocol
UHF	Ultra-High Frequency
USD	United States Dollar
VCO	Voltage Controlled Oscillator
VCTCXO	Voltage-Controlled Temperature-Compensated Crystal Oscillator
VRMS	Volts Root Mean Square
VRRP	Virtual Router Redundancy Protocol
VSWR	Voltage Standing Wave Ratio



## 1 TORNADO X SYSTEM OVERVIEW

Mimomax Tornado X delivers the next generation of high performance true MiMO narrowband remote radios for SCADA, Protection and Linking applications. The Tornado X is the market leader for narrowband throughput and functionality with a full duplex aggregate data rate of up to 640kb/s in 50kHz in its highest modulation mode.

Tornado X radios provide a radio wireless infrastructure for connecting devices used by various applications to form a network through which IP data, RS-232 serial data or RS485 synchronous serial data can seamlessly flow. Features include isolated power supply in Tornado X and non-isolated power supply in Tornado XR, full duplex operation with built in duplexers and supporting a combination of interfaces, with very high scalable data rates, remote over the air network management, optional SNMP, ModBus and DNP3 support and a very efficient random-access protocol.

Operating in the licensed frequency bands at 700MHz Upper A-Block, with a wide temperature operating range and optional waterproof outdoor mount. The Tornado X enables unrivalled performance while maintaining Mimomax's renowned reputation for reliability and operational efficiency.

There are two different form factors for Tornado X series: Tornado X and Tornado XR. Tornado X radio can be configured as Network Digital Links (NDL) and Multipoint Digital Links (MDL) and Optimized Protection Variant (OPV) of the NDL link. Tornado XR radio can only be configured as Multipoint Digital Links (MDL) remote. The one Tornado radio platform can be configured differently for the different roles required by these links through the enabling and disabling of features and functionalities.

### 1.1 NETWORK DIGITAL LINKS (NDL)

The Mimomax NDL is a highly reliable and robust point-to-point wireless linking solution designed to support PMR Linking, SCADA and Backhaul applications.

An NDL link is a simple point-to-point over-the-air connection between two Tornado X radios in NDL mode. One is configured as master, the other as slave. This link allows for very quick data transfer. Modulation can be fixed or adaptive.



*Simple NDL Link Diagram*

Utilizing the MiMO technology and full-duplex operation, this narrowband fixed wireless solution provides a reliable low-error data transport service. A number of internal interfaces are available to support various SCADA applications and also multichannel, conventional, analogue, simulcast, MPT, P25 and/or TETRA digital networks in trunked and simulcast configurations.

For PMR applications, a separate high-quality Network Interface Box (NIB) with up to 6 x 32k ADPCM audio channels plus 9k6 RS232 signalling channel, supports analogue networks.

Multiple links can be cascaded to cope with difficult terrain and very long paths. Different mounting options provide the much-needed flexibility for varied network requirements. Being fully compatible with the rest of the Mimomax product types, NDL can be incorporated into the Mimomax MDL (point-to-multipoint) linking solution.

NDL links are well-suited for providing backhaul links between sites in P25, DMR and MPT networks. Each link can carry multiple voice channels (the number varies with the modulation scheme) and have residual bandwidth for maintenance tasks. A high priority queue is available to provide EF priority to voice and other critical data over the link. The following diagram shows a simplified two-site trunked P25 network with an NDL link providing the backhaul between the remote site and the central site.

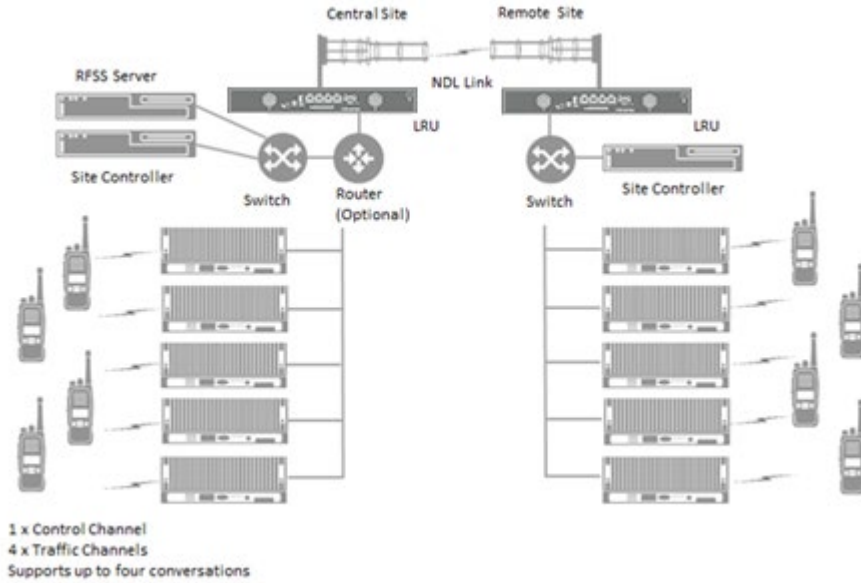

*Simplified Two-Site Trunked P25 Network*

## 1.2 MULTIPOINT DIGITAL LINKS (MDL)

The Mimomax MDL is a highly reliable and robust point-to-multipoint wireless linking solution designed for mission-critical Supervisory Control and Data Acquisition (SCADA) and Telemetry applications. It consists of one or more Base Radio Units (BRUs) where each BRU supports up to 354 active Remote Radio Units (RRUs) with largest settable RRU ID of 356. An exception to it is 4.6.x series which were limited to support up to 135 RRUs while still maintaining IDs settable between 3 and 356.

The Mimomax MDL supports both native IP and legacy Asynchronous Serial RS232 Remote Terminal Units (RTUs) by means of optional embedded Terminal Server software. A number of interfaces are available to support various applications. Additionally, the system is capable of supporting remote outstations simultaneously on different modulation schemes to accommodate various data rates and link paths.

Very high system gains and good receiver sensitivities mean that it is possible to achieve paths in excess of 100kms from high radio sites at full speed. Furthermore, any branch of MDL can be extended by using the Mimomax point-to-point Network Digital Link (NDL) radio communications solution.

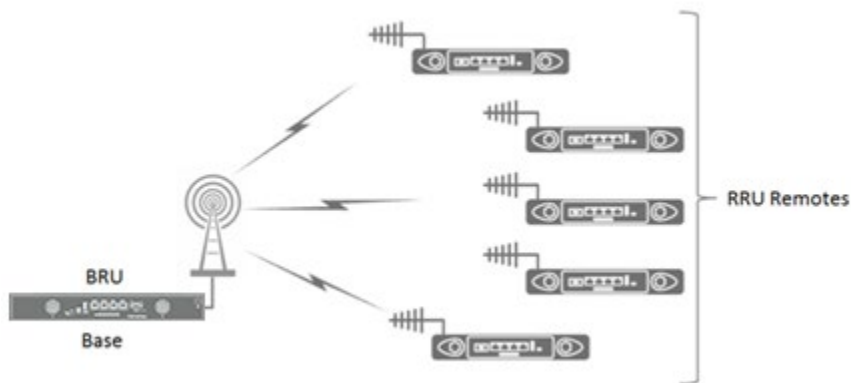

*Basic Point-to-Multipoint Linking Diagram*

SCADA networks can use MDL links to connect remote RTUs to the central SCADA master. These links can be cascaded with an NDL link to cope with difficult terrain or very long paths.

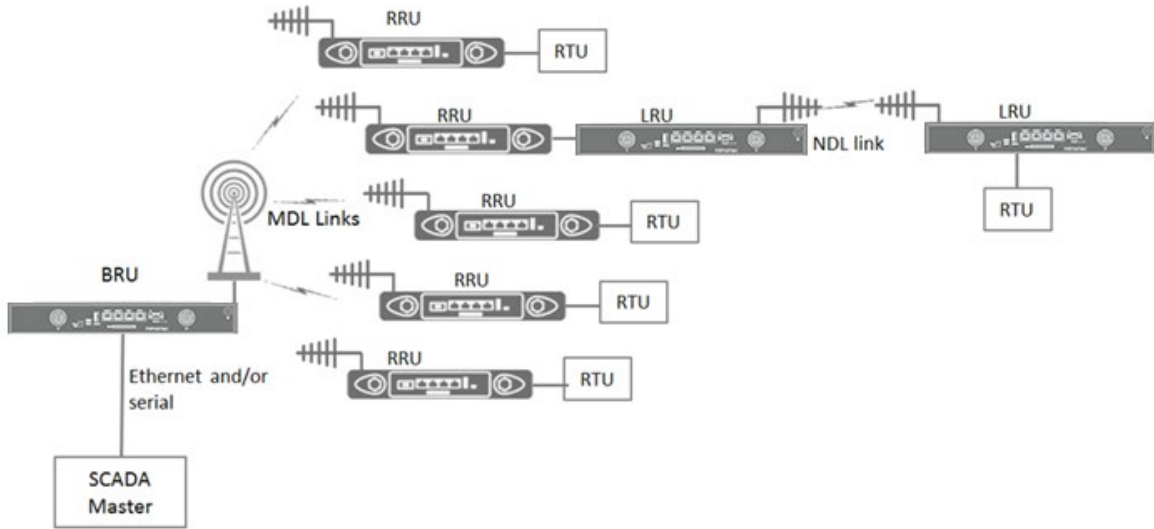

SCADA Network Example

### 1.3 OPTIMIZED PROTECTION VARIANT (OPV)

The Mimomax OPV is a highly intelligent point-to-point radio system that provides complete rural substation Teleprotection communications solution for both power line protection and SCADA applications. It is designed to meet CAT I, II and III protection levels. Hence, can be employed to link power line protection relays (e.g. General Electric L90) within critical network infrastructure.

In addition to providing a low latency, low jitter 64kbps protection channel, it also provides at least 64kbps Ethernet capacity over the same radio link. The protection relays typically use the radio link to exchange data packets at 64kbps, containing power system voltage and current magnitude and phase angle information. This information is used to determine whether there is an unexpected event or power loss on the line and to transmit information used to trip circuit breakers when a line fault is detected.

The interface required for the protection relays is typically synchronous serial using V11 (RS422), X-21 or G703 signaling at 64kbps transmission rate. However, a number of other synchronous serial interfaces can also be accommodated. Furthermore, multiple layers of security ensure that the mission-critical operations remain highly secure.

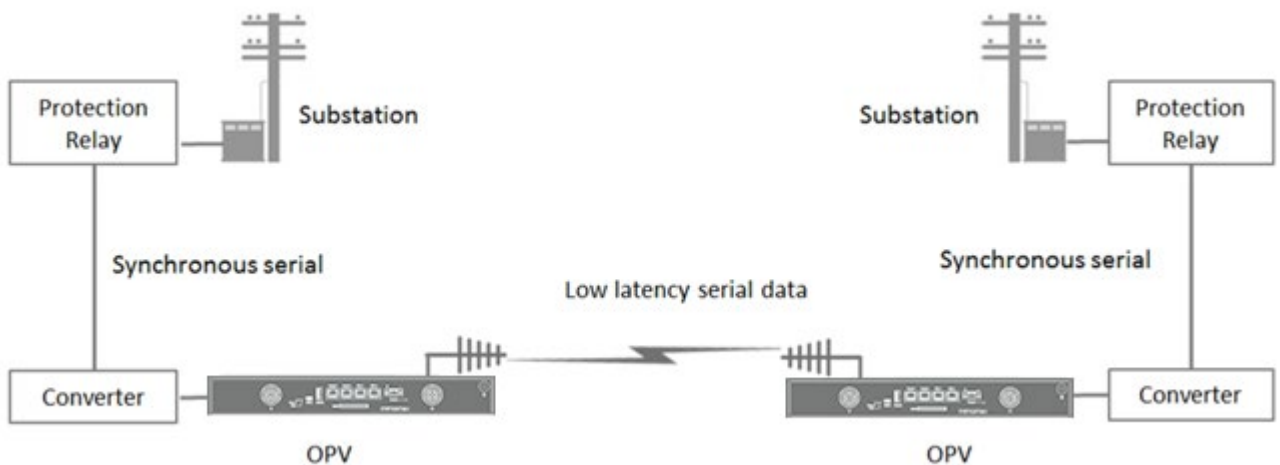

OPV Example Network Diagram

## Mimomax Tornado OPV-T Synchronous Serial Latency Table

Bandwidth	Modulation	X21 64kbps	X21 128kbps	X21 192kbps	X21 256kbps	RS422 64kbps	RS422 128kbps	RS422 192kbps	RS422 256kbps	C37.94	G703
50kHz	QPSK	4.6	4.5	-	-	4.4	4.5	-	-	5.3	5.2
	16QAM	2.9	2.8	2.8	2.7	3.0	2.8	2.6	2.7	3.7	3.5
	64QAM	2.4	2.2	2.2	2.2	2.3	2.2	2.2	2.2	3.1	2.9
	256QAM	2.1	1.9	1.9	1.9	2.2	1.9	1.9	1.8	2.7	2.6
25kHz	QPSK	9.0	-	-	-	9.0	-	-	-	9.5	9.5
	16QAM	5.5	5.0	-	-	5.5	5.0	-	-	5.9	5.9
	64QAM	4.5	4.4	4.2	-	4.5	4.4	4.2	-	4.8	4.8
	256QAM	4.0	3.8	3.6	3.6	4.0	3.8	3.6	3.6	4.3	4.3
12.5kHz	QPSK	-	-	-	-	-	-	-	-	-	-
	16QAM	10.7	-	-	-	10.7	-	-	-	11.0	11.0
	64QAM	8.0	-	-	-	8.0	-	-	-	9.0	9.0
	256QAM	7.5	7.2	-	-	7.5	7.2	-	-	8.0	8.0

Note 1: Latencies figures are in milliseconds

Note 2: Latencies figures are for a single radio hop and are one way (not round trip)

## 2 SAFETY WARNINGS

### 2.1 MODIFICATIONS

NOTE: THE GRANTEE IS NOT RESPONSIBLE FOR ANY CHANGES OR MODIFICATIONS NOT EXPRESSLY APPROVED BY THE PARTY RESPONSIBLE FOR COMPLIANCE. SUCH MODIFICATIONS COULD VOID THE USER'S AUTHORITY TO OPERATE THE EQUIPMENT.

### 2.2 TRANSMITTER ANTENNA

Under Industry Canada regulations, this radio transmitter may only operate using an antenna of a type and maximum (or lesser) gain approved for the transmitter by Industry Canada.

To reduce potential radio interference to other users, the antenna type and its gain should be so chosen that the equivalent isotropically radiated power (E.I.R.P.) is not more than that necessary for successful communication.

Conformément à la réglementation d'Industrie Canada, le présent émetteur radio peut fonctionner avec une antenne d'un type et d'un gain maximal (ou inférieur) approuvé pour l'émetteur par Industrie Canada.

Dans le but de réduire les risques de brouillage radioélectrique à l'intention des autres utilisateurs, il faut choisir le type d'antenne et son gain de sorte que la puissance isotrope rayonnée équivalente (E.I.R.P.) ne dépasse pas l'intensité nécessaire à l'établissement d'une communication satisfaisante.

#### 2.2.1 TORNADO X AND TORNADO XR 700MHZ TRANSMITTER ANTENNA

Below antennas from Mimomax Wireless are recommended to use with Tornado X and Tornado XR.

Dual Polarized Omni-Directional Antenna	8dBi, 2xN Female
Dual Polarized Compact Panel Antenna	8dBi, 2xN Female
Dual Polarized, MiMO Directional Panel Antenna	9dBi, 2xN Female
Compact Panel Antenna	9dBi, 2xN Female / 2x4.3-10 Female
Compact Panel Antenna	11dBi, 2xN Female / 2x4.3-10 Female
MiMO Low Profile Panel Antenna	12dBi, 2xN Female
MiMO Panel Antenna	16dBi, 2xN Female / 2x4.3-10 Female
MiMO Yagi Antenna (with optional Radome available)	12dBi, 2xN Female
Dual Polarized MiMO Yagi Antenna (with optional Radome available)	15dBi, 2xN Female

According to FCC compliance requirement on maximum E.R.P limitation specified in CFR47 part 27.50, an antenna with maximum gain of 28.06dBi or 12.83 dBi is allowed to use for 757-758MHz band and 787-788MHz band respectively. The use of other antennas with higher gain should be combined with tuning down the Tornado X or Tornado XR transmitter output power to appropriate level to assure the system E.R.P (or E.I.R.P) meets the FCC requirement.

### 2.3 SAFETY DISTANCE

Minimum Safe Distance from Antenna: To comply with safety requirements for human RF exposure in the USA, Canada and other countries, no person shall be permitted to remain in the vicinity of the antenna of an operational Mimomax Tornado system at distances closer than the following:

#### 2.3.1 TORNADO X AND TORNADO XR 700MHZ SAFETY DISTANCE

General Public/Uncontrolled Use: 0.84m when using an 16dBi Panel Antenna with a Mimomax Tornado X or Tornado XR radio.

The above distances are based on procedures defined by regulatory standards for equipment operating at maximum power and 100% duty cycle with a person located directly in front of the antenna in the main radiation lobe.

## **2.4 FCC RF EXPOSURE STATEMENT**

The transmitter must not be co-located or operated in conjunction with any other antenna or transmitter. The equipment complies with FCC RF radiation exposure limits set forth for an uncontrolled environment.

### **2.4.1 TORNADO 700MHZ FCC RF EXPOSURE STATEMENT**

This equipment should be installed and operated with a minimum distance of 105cm between the radiator and any part of your body.

## **2.5 ELECTRICAL SAFETY CABLE SCREENING**

Equipment connected to the protective earthing of the building installation through the mains connection or through other equipment with a connection to protective earthing - and to a cable distribution system using coaxial cable, may in some circumstances create a fire hazard. Connection to a cable distribution system has therefore to be provided through a device providing electrical isolation below a certain frequency range (galvanic isolator, see EN 60728-11).

NOTE: In Norway, due to regulation for installations of cable distribution systems, and in Sweden, a galvanic isolator shall provide electrical insulation below 5 MHz. The insulation shall withstand a dielectric strength of 1,5 kV r.m.s., 50 Hz or 60 Hz, for 1 min.

Utstyr som er koplet til beskyttelsesjord via nettplugg og/eller via annet jordtilkoplede utstyr - og er tilkoplede et kabel-TV nett, kan forårsake brannfare. For å unngå dette skal det ved tilkopling av utstyret til kabel-TV nettet installeres en galvanisk isolator mellom utstyret og kabel-TV nettet.

Utrustning som är kopplad till skyddsjord via jordat vägguttag och/eller via annan utrustning och samtidigt är kopplad till kabel-TV nät kan i vissa fall medföra risk för brand. För att undvika detta skall vid anslutning av utrustningen till kabel-TV nät galvanisk isolator finnas mellan utrustningen och kabel-TV nätet.

## 2.6 MAINS CONNECTION

The Mains connection of the supply providing the DC supply to the Mimomax Tornado X or XR unit shall be either:

- PERMANENTLY CONNECTED EQUIPMENT.
- PLUGGABLE EQUIPMENT TYPE B.
- Or equipment intended to be used in a RESTRICTED ACCESS LOCATION where equipotential bonding has been applied and which has provision for a permanently connected PROTECTIVE EARTHING CONDUCTOR and is provided with instructions for the installation of that conductor by a SERVICE PERSON.

## 2.7 FCC 15.19 STATEMENT

THIS DEVICE COMPLIES WITH PART 15 OF THE FCC RULES. OPERATION IS SUBJECT TO THE FOLLOWING TWO CONDITIONS: (1) THIS DEVICE MAY NOT CAUSE HARMFUL INTERFERENCE, AND (2) THIS DEVICE MUST ACCEPT ANY INTERFERENCE RECEIVED, INCLUDING INTERFERENCE THAT MAY CAUSE UNDESIRE OPERATION.

## 2.8 FCC 15.105(B) STATEMENT

Note: This equipment has been tested and found to comply with the limits for a Class B digital device, pursuant to part 15 of the FCC Rules. These limits are designed to provide reasonable protection against harmful interference in a residential installation. This equipment generates, uses and can radiate radio frequency energy and, if not installed and used in accordance with the instructions, may cause harmful interference to radio communications. However, there is no guarantee that interference will not occur in a particular installation. If this equipment does cause harmful interference to radio or television reception, which can be determined by turning the equipment off and on, the user is encouraged to try to correct the interference by one or more of the following measures:

- Reorient or relocate the receiving antenna.
- Increase the separation between the equipment and receiver.
- Connect the equipment into an outlet on a circuit different from that to which the receiver is connected.
- Consult the dealer or an experienced radio/TV technician for help.

### 3 TORNADO RADIO UNIT OVERVIEW

#### 3.1 CONNECTORS

The image below shows each of the different connectors. The Ethernet connectors are 10/100 Base-Tx connected to a two-port switch (either port can be used). The operating input voltage range of the power supply is 10.5 to 64 VDC. For Tornado X, the power supply must be able to supply at least 70 watts. For Tornado XR, the power supply must be able to supply at least 30 watts.

**Warning: Do not power up the radio unit without an RF load (attenuator or antenna) connected to each of the N connectors. Damage to the radio may occur otherwise.**

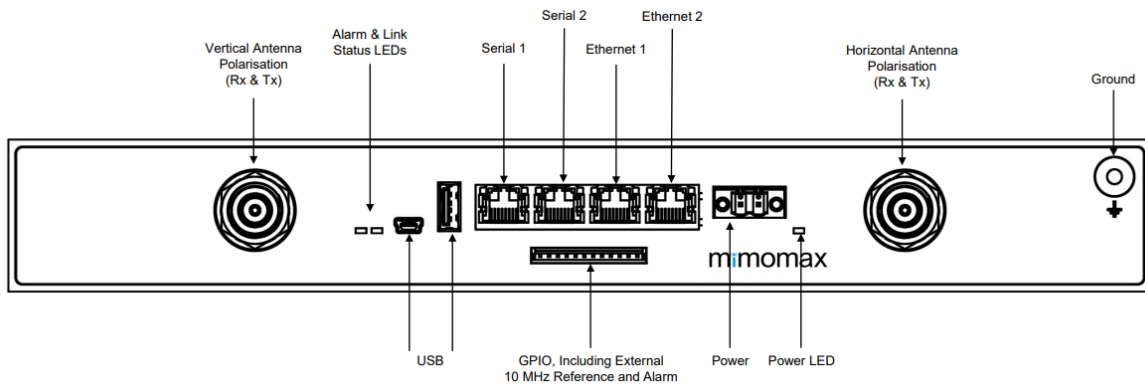

*Tornado X Connectors*

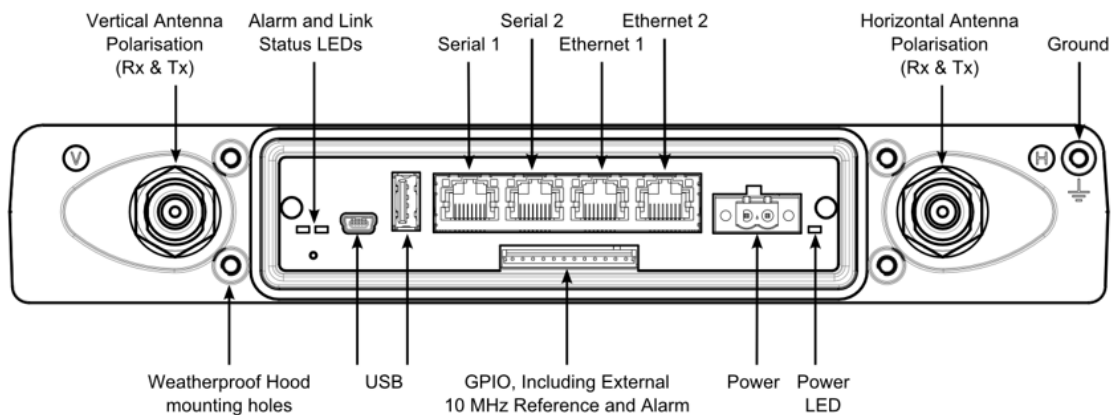

*Tornado XR Connectors*

Tornado X radio units can operate as either a Base Radio Unit (BRU) or Remote Radio Unit (RRU) as part of a Multi-point Digital Link (MDL) system or alternatively as a NDLE unit as part of a Network Digital Link (NDL) system.

Tornado XR radio unit can only operate as Remote Radio Unit (RRU) as part of a Multipoint Digital Link (MDL) system.

The actual mode of operation will depend on the Software Feature Enablers (SFEs) purchased and the product type configured.

An MDL system consists of one BRU, tuned to one Tx/Rx frequency pair, with a number of RRUs, all tuned to the corresponding, but opposite, Tx/Rx frequency pair. An NDL system consists of one 'master' NDL unit tuned to one frequency pair with its corresponding 'slave' unit tuned to the opposite pair.

Mimomax Tornado X and Tornado XR radios consist of the following modules.



- Digital Processing System (DPS)
- Transceiver (TRCVR)
- Duplexers (DPLXR)

These modules are described in detail in the sections that follow.

User data (Ethernet or serial) passes from the various interfaces into the Digital Processing System (DPS) where sophisticated processing takes place to code the data into a MIMO signal. This MIMO signal is created completely digitally inside the DPS. The DPS then generates two signals at an IF frequency. There are two uncorrelated signals because ultimately the signals will pass onto separate elements on the antenna. The Intermediate Frequency (IF) signals are then passed on to the Transmitter module which mixes the signals up to the desired frequency and also amplifies the signals to the required levels. The signals then pass through the duplexers. The duplexers are special filters which prevent the transmitted signals from feeding back into the receiver module. Next the signals are fed to the antenna.

The antenna is a special MIMO antenna which is able to transmit and receive on both the vertical and horizontal polarisations at the same time. The MIMO antennas are essentially two antennas in one.

On the receive path, the radio signals are picked up by the MIMO antenna and fed through the duplexers and into the receiver module. The receiver selects the radio frequency to receive and mixes this signal down to an IF. This IF signal is then sampled by Analogue to Digital Converters (ADCs) on the DPS module. The DPS module then performs very complex MIMO processing to decode the user data that was sent. This data is then passed to the appropriate interface.

## 3.2 DIGITAL PROCESSING SYSTEM

The DPS is the heart of the radio unit. It provides an accurate and stable 40MHz system reference clock from which all the required digital clocks and RF local oscillator frequencies for transmit and receive functions are derived. It processes signals that have been transmitted or received and provides overall control and monitoring to the rest of the system via the built-in Configuration, Control and Management Software CCMS software. Power supplies are also provided by the DPS.

### 3.2.1 POWER SUPPLY

The power supply operates off a 10.5 to 60 VDC input and generates stable 13.6V, 5.8V, 5.0V, 3.3V, 2.5V, 1.8V, 1.2V and 18V internal power supply rails, that all the other circuitry runs off.

The base station Tornado has an isolated input power supply, and the Remote Tornado has a non-isolated Power supply.

#### 3.2.1.1 Tornado X Radio

The input of the power supply is isolated from the rest of the circuitry and the chassis. Input voltage monitoring is provided via CCMS.

#### 3.2.1.2 Tornado XR Radio

The input of the power supply is non-isolated. Input voltage monitoring is provided via CCMS.

### 3.2.2 CENTRAL PROCESSOR UNIT

An ARM Cortex A8 based microcontroller is used as the CPU in the DPS board. It uses a reference clock of 26MHz. The CPU provides external device connectivity through the built-in and external peripherals.

The CPU runs a Linux embedded operating system which provides various services such as scheduling, process management, memory management, device and resource management, TCP/IP stacks and inter-networking, applications, user interface, system configuration and control etc. An integral part of the Linux operating system is the Mimomax specific network driver, which configures the radio unit as a standard Ethernet device.

### 3.2.3 FPGA

An Altera Cyclone IV Field Programmable Gate Array is used to implement the physical layer TX and Rx signal processing, MAC layer and signalling protocols on the serial interfaces.

### 3.2.4 RECEIVE CONVERTERS

The 45.1MHz analogue IF signals from each receiver channel are fed to a dual 10-bit ADC. The signals are sampled using a 40MHz clock which is generated from the 40MHz system reference clock. The digital outputs from the ADC are fed to the FPGA for processing.

### 3.2.5 TRANSMIT CONVERTERS

The digital transmit signals from the FPGA are fed to a dual 14-bit DAC which uses a clock frequency of 40MHz to produce the analogue IF signal for each transmitter channel. The IF output is 13.333333MHz. This is chosen in conjunction with the transmitter local oscillator frequency to minimise the generation of spurious frequencies in the transmitted RF output spectrum.

### 3.2.6 REFERENCE & CLOCK SYNTHESISERS

The main system reference clock consists of a low-noise, voltage-controlled, temperature-compensated, crystal oscillator (VCTCXO) operating at 40MHz. Factory calibration of this oscillator against an external GPS or other frequency reference is provided by means of a non-volatile sample-and-hold facility which adjusts the VCTCXO DC control voltage to set the frequency precisely to 40.0MHz. The VCTCXO may also be phase-locked to an external 10 MHz reference if required. If the external reference input is not in use the internal reference divided down to 10 MHz can be provided as an output. External reference in/out is provided via an isolated differential connection on the GPIO connector.

The 40MHz output from the VCTCXO is buffered and distributed to provide low-noise differential reference signals for the transmitter and receiver local oscillators, transmit DACs, receive ADCs and the FPGA.

The 40MHz output from the VCTCXO also feeds a PLL IC which generates a 26MHz clock for the CPU and a 25MHz clock for the Ethernet controller IC.

### 3.2.7 DUAL ETHERNET

The Ethernet is provided via a three-port managed Ethernet switch, one port is the internal connection to the CPU, and the other two ports are available on the RJ45 connectors labelled 'Eth1' and 'Eth2' on the front panel. The Ethernet ports are both 10/100BASE-Tx ports, supporting full and half duplex, flow control, auto MDI-X and auto negotiation.

### 3.2.8 DUAL SERIAL

The two serial ports, 'Serial 1' and 'Serial 2' on the front panel, operate as RS232 ports can either operate via a terminal server application (NDL and MDL) or providing a transparent end to end RS232 connection (NDL only). In a NDL system the serial ports are also able to provide X-21, RS422, G703, C37.94 or Mimomax HSSI2 via external interface converters.

### 3.2.9 GPIO

Four GPIO ports are provided, these are able to be open collector digital outputs capable of withstanding 70 VDC, and sinking up to 100mA. Or they can be used as either digital or analogue input ports, making use of a 12-bit Analogue to Digital converter. The direction and mode of each can be set independently.

### 3.2.10 ALARM

A single set of voltage free change over contacts are provided as an alarm indication, these are current limited to 750mA. The alarm port is also on the GPIO connector.

### 3.2.11 FRONT PANEL LEDS

LEDs on the front panel indicate Power, RF link status and Alarm. A green LED by the power connector is on when the internal 3.3 Volt power supply is on. A green LED labelled 'Link' is on when a RF link is active. A red LED labelled 'Alarm' flashes during boot up. It will also flash when the alarm is active.

### 3.3 RECEIVER RF/IF SECTIONS

The receiver has two identical channels, each with separate RF, mixer and IF stages. A common local oscillator feeds both channels simultaneously. RF input to each channel is by means of a PCB-mounted 50Ω SMB connector. With the exception of the VCO/synthesiser sections the descriptions below apply equally to either receiver channel.

#### 3.3.1 FRONT END

The Front End starts with the incoming signals fed through a band pass duplexer which provides effective rejection of out-of-band frequencies beyond the centre frequency (approximately +/-3MHz). Following the filter, is the receiver Low Noise Amplifier (LNA). This is followed by a fixed image reject filter to remove noise attributed to the LNA as the majority of image rejection comes from the internal duplexers.

#### 3.3.2 MIXER AND LO BUFFER

The RF signal from the front end is converted down to an Intermediate Frequency (IF) by means of a mixer and LO Buffer.

#### 3.3.3 IF AND AGC CIRCUITRY

The signal from the mixer feeds a 45.1MHz 4-pole crystal filter. It then passes via a buffer amplifier to a second IF filter which is a 2-pole crystal unit. This gives a total of 6 poles of analogue IF filtering. Primary rejection of adjacent channels is provided by post-IF DSP filtering further down the receive chain.

Following the second IF filter are two-stage variable-gain AGC amplifiers which provide >100dB effective gain adjustment, using a DC control voltage derived from a 10-bit DAC. The balanced output from the second stage amplifier is fed via an anti-aliasing band pass filter to an analogue-to-digital converter (ADC) and subsequent digital processing circuitry.

At maximum gain the 45.1MHz IF amplifier chain provides >90dB gain from 1st IF filter input to the balanced IF output (total receiver gain from RF input to IF output: >100dB). In operation, the post-IF receiver processing circuitry adjusts the AGC control voltage via the DAC to maintain the signal level into the receiver ADC within its linear operating region.

#### 3.3.4 LOCAL OSCILLATOR

The receiver local oscillator consists of a programmable fractional-N phase-locked loop (PLL) frequency synthesiser, using a stable reference frequency from an internal 40MHz temperature-compensated crystal oscillator located on the DPS PCB. The required local oscillator frequency (i.e. receive frequency minus 45.1MHz) is programmed by the unit central processing system which controls the synthesiser via a 3-wire serial interface bus. The frequency is settable in 6.25 kHz increments (5 kHz optional).

The synthesiser control loop incorporates a low noise op-amp active filter and level shifter, the output of which feeds the voltage-controlled oscillator (VCO). The VCO uses a LC resonator tuned by high-Q varicap diodes to minimise phase noise and jitter. The required local oscillator frequency ranges from 711.9 to 742.9MHz.

The output of the VCO passes through an RF cascade buffer IC, which amplifies the low-level signal from VCO whilst providing high reverse isolation to minimise any variations in VCO loading. The output feeds the splitter network and in turn feed the mixers of each receiver channel.

### 3.4 TRANSMITTER RF/IF SECTIONS

The transmitter has two channels, each with separate RF, up/down converter, and IF stages. The power supplies and stepped attenuator settings can be independently controlled. A common local oscillator feeds both channels simultaneously. RF output from each channel is by means of a PCB-mounted 50Ω SMB connector. With the exception of the VCO/synthesiser sections the descriptions below apply equally to either transmit channel.

#### 3.4.1 FORWARD SIGNAL PATH

The transmitter employs a fixed frequency 'direct IF' with single up conversion to the final RF. It includes fixed IF filters to attenuate DAC spurs. The mixer is a quadrature up converter and also provides an image reject function due to 90deg phase splitting of the input signal. The adjustment of gain is provided by a 1.5-33.5dB stepped attenuator programmable in 0.5dB steps. Power amplification follows consisting of devices biased to provide a reasonably linear characteristic to support the required modulation types. A directional coupler on the PA output provides a sample of the signal for the feedback path. The PA bias is controlled via DAC outputs. The PA bias

tracks temperature based on a predefined tracking curve. An ADC monitor measures PA final and drivers current, forward and reverse power. PA temperature is monitored for each channel by dedicated temperature sensors.

#### 3.4.2 FEEDBACK SIGNAL PATH

The RF signal from the directional coupler has adjustment of gain provided by a 1.5-33dB step attenuator programmable in 0.5dB steps. The RF signal is down converted to a 13.333333MHz IF feedback signal which is the same as the forward path signal. This IF signal is amplified and summed with the forward path to close the transmitter linearizer loop.

#### 3.4.3 LOCAL OSCILLATOR

The transmitter has two local oscillators, a main forward path LO and a reverse path LO which is synchronized with the main one. The main LO consists of a programmable fractional-N phase-locked loop (PLL) frequency synthesiser. This uses a stable reference frequency derived from the DPS 40MHz clock. The required local oscillator frequency (i.e. transmit frequency minus TX IF) is programmed via a serial interface bus from the DPS. The LO frequency can be set in 5 kHz increments. The secondary LO has an identical VCO as the main LO and a FPD as a discrete PLL block that controls the secondary VCO to generate appropriate frequency for Tx reverse path.

The main synthesizer control loop incorporates a low noise op-amp active filter and level shifter, the output of which feeds the voltage-controlled oscillator (VCO). The VCO uses a LC resonator tuned by high-Q varicap diodes to minimize phase noise and jitter. The required main local oscillator frequency range is 757MHz to 788MHz (31MHz total for 700MHz Tornado X and XR). The secondary LO FPD is disciplined by the main LO and a 13.333333MHz reference clock. The secondary LO frequency range is 743.666666MHz to 774.666666MHz.

The output of the VCOs passes through a resistive attenuator into a buffer amplifier which raises the power level. This is followed by two Wilkinson splitter networks, resulting in four 50Ω outputs. These outputs feed the up conversion and down conversion mixers for each of the two transmitter channels.

#### 3.4.4 INTERNAL DUPLEXER

The duplexer takes one receiver and one transmitter and duplexes them onto a single antenna port. Two duplexers are used in each radio unit. The antenna port connector is a waterproof N-type. Connections to the receiver and transmitter printed circuit assemblies are made internally via two 50Ω SMB connectors and interconnecting semi-flexible coax cables. Each duplexer has two band pass filters with notches.

Electrically the two duplexers in each radio unit are identical. Physically they are different and present almost a mirror image of the other. These are referred to as 'Channel 1' for polarization port H and 'Channel 2' for polarization port V. The duplexers cannot be swapped over.

## 4 SETTING UP ON THE BENCH

The radio units can be interconnected for bench-based testing or configuration. Attenuators with appropriate attenuation and power handling must be used. The RF wiring diagram shows the interconnection of attenuators, cables and splitters for a standard bench test.

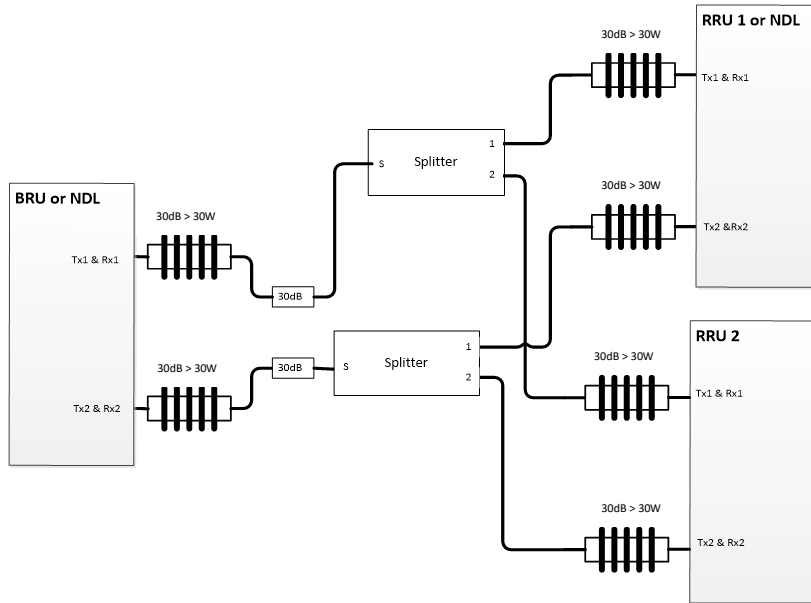

Note: If an NDL system or an MDL system with only one RRU is desired then the splitters, second RRU and corresponding attenuators can be omitted. Mimomax can supply a splitter that provides 4 ports and ~30dB attenuation.

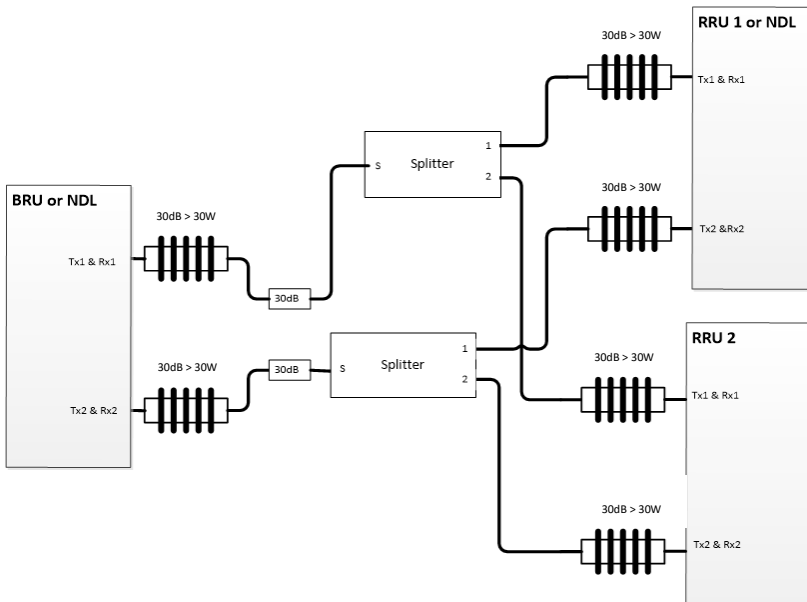

Recommended equipment:

- 6x high power RF attenuators (30 dB, >30 W)
- 2x low power RF attenuators (30dB, > 1W)
- 2x RF splitters
- Sufficient RF cables and adaptors to connect the above devices to the radio units

### 4.1 TESTING THE NETWORK SETUP

Once the RF setup has been completed the radio units can be powered up, networking on associated devices configured and the units logged into. Refer to the label located on the underside of the radio unit to identify the configured IP address and subnet mask. The image below shows an example IP diagram of the network in Router mode. The following one shows an example of same network in Bridged mode. We generally recommend setting up MDL in Bridged mode because the network settings are simpler however it depends on your IP planning for the multipoint network.

First, we connect to each radio unit locally. To do this, configure the IP address, subnet mask and gateway of the connected device or laptop. It is crucial that the laptops/devices are on the same subnet as the Tornado's and also that their gateway is set to the Tornado's IP address. This means you will need to reconfigure the IP information if moving the laptop between radio units.

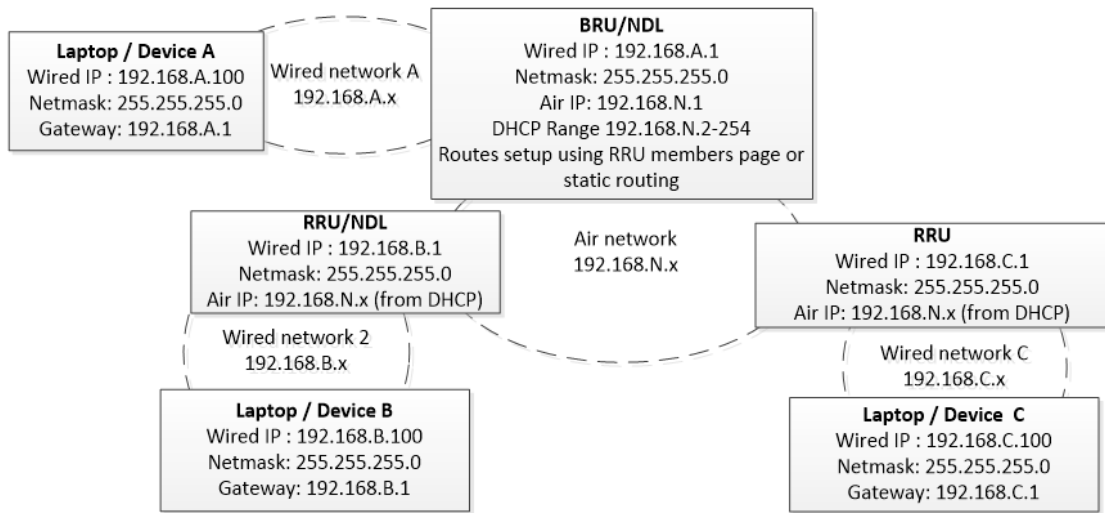

Example IP diagram using 192.168.x.x subnets (Routed mode)

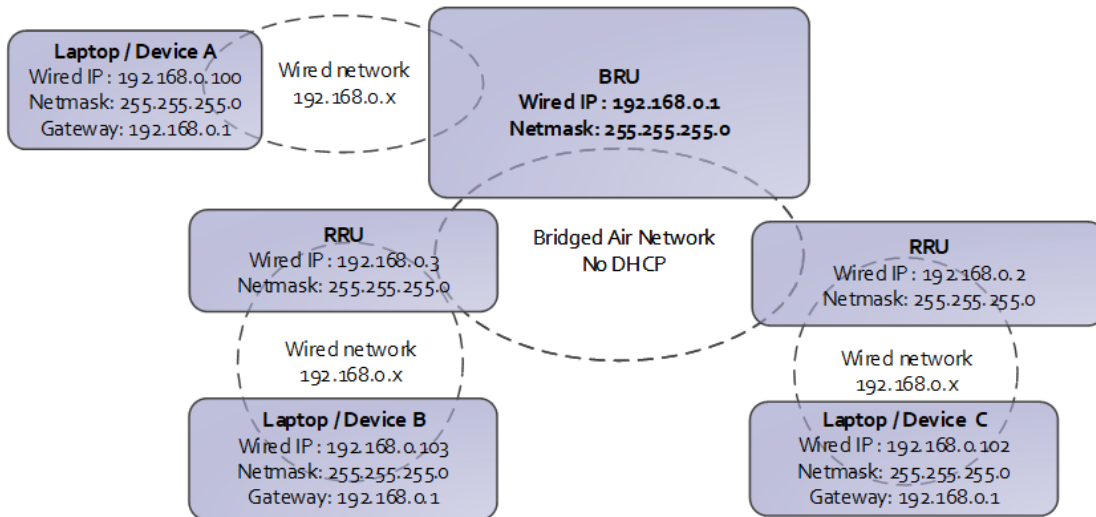

Example IP diagram using a single subnet (Bridged mode)

Next confirm network connectivity by pinging each radio unit from the connected laptop. If this is not successful, use ipconfig to check your networking settings. Once we have network connectivity with the local radio unit, type the appropriate IP address into your web browser to access the unit.

```
C:\>ipconfig
Windows IP Configuration

Ethernet adapter Local Area Connection 9:

    Connection-specific DNS Suffix  . : 
    Link-local IPv6 Address . . . . . : fe80::c5cd:db78:b35d:eccc%35
    IPv4 Address. . . . . : 192.168.0.15
    Subnet Mask . . . . . : 255.255.255.0
    Default Gateway . . . . . :
```

```
C:\>ping 192.168.0.1
Pinging 192.168.0.1 with 32 bytes of data:
Reply from 192.168.0.1: bytes=32 time=1ms TTL=64
Reply from 192.168.0.1: bytes=32 time=1ms TTL=64
Reply from 192.168.0.1: bytes=32 time=1ms TTL=64
Reply from 192.168.0.1: bytes=32 time=1ms TTL=64

Ping statistics for 192.168.0.1:
    Packets: Sent = 4, Received = 4, Lost = 0 (0% loss),
    Approximate round trip times in milli-seconds:
        Minimum = 1ms, Maximum = 1ms, Average = 1ms
```

*Figure 1 Ipconfig on the left (In this case the gateway has not been set properly!) and on the right Pinging 192.168.0.1 (the BRU) from Laptop A*

You are now ready to log in, configure, and monitor the system.

## 5 CONFIGURATION CONTROL AND MONITORING SYSTEM (CCMS)

CCMS is web-based software that enables you to connect to a Mimomax radio unit using a web browser such as Internet Explorer, Firefox or Chrome. No application other than a web browser needs to be installed on your PC or laptop. The radio unit serves up the CCMS web pages. For a full list of functions please refer to Mimomax's Tornado CCMS Manual.



## 6 CHANGING OPERATING FREQUENCY AND POWER CALIBRATION

### 6.1 INTRODUCTION

Changing operating frequencies of a Mimomax Tornado radio is done via the CCMS. The radio's power will need to be recalibrated and the internal duplexers also need to be re-tuned. Duplexer tuning is covered in Section 7.

### 6.2 EQUIPMENT REQUIRED: POWER METER

For accurate measurement of average power from Mimomax transmitters a thermistor bolometer type of power meter (e.g. HP435A or similar) is required. Other types of power meter may give inaccurate average power readings when used with Mimomax transmitters and may be suitable only for relative power measurement.

The transmitters are accurately set up in the factory to produce 2.5W (+34dBm) average power output. To avoid compromising spectral purity it is very important that the power output be set no higher than this.

### 6.3 PROCESS OVERVIEW

The process of changing frequencies can be seen below.

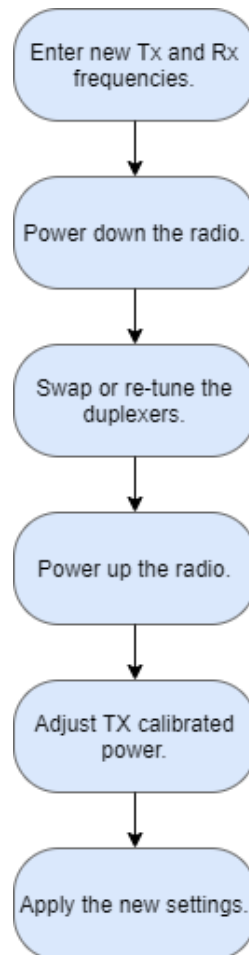

*Frequency change process*

### 6.4 CCMS PROCESS

To start the process, click on **RF TX and Rx**. This page displays the transmitter power level, TX and Rx frequencies. It is strongly advised to set the unit to +34dBm output power and to measure the transmit power before starting the process. This can be used as a reference power should you not have an accurate power meter. The units were factory calibrated to +34dBm, +/-0.2dB.

### Configure RF Transmitter & Receiver

Transmitter frequency (MHz)	<input type="text" value="787.95"/>
Receiver frequency (MHz)	<input type="text" value="757.05"/>
Transmitter power	<input type="text" value="34"/>
Transmitter power unit	<input type="text" value="dBm"/>
Duplexers	<input type="text" value="Internal"/>

### RSSI Attenuation

Rx1 RSSI Offset (dB)	<input type="text" value="0"/>
Rx1 RSSI Attenuation	<input type="text" value="Disabled"/>
Rx2 RSSI Offset (dB)	<input type="text" value="0"/>
Rx2 RSSI Attenuation	<input type="text" value="Disabled"/>

### Advanced Configuration

Tracking algorithm rate of adaptation	<input type="text" value="Normal"/>
Tracking algorithm adaptation delay	<input type="text" value="Disabled"/>
Retrain detection time (ms)	<input type="text" value="50"/>

### [Retune Frequencies](#)

Tx Synth: **Locked**  
 Rx Synth: **Not Locked**

*Configure RF CCMS Page*

To change the Tx and Rx frequencies on the radio, click **Retune Frequencies**. This will take you to a new page.

### Retune Frequencies

#### Current frequencies

Transmitter frequency (MHz)	787.95
Receiver frequency (MHz)	757.05

#### New frequencies

New transmitter frequency (MHz)	<input type="text" value="787.05"/>
New receiver frequency (MHz)	<input type="text" value="757.95"/>

*Retune Frequencies CCMS Page*

On this page, enter the new Tx and Rx frequencies. The above image shows an example of this. Afterwards, click **Next** to continue the process.

**Retune Frequencies**

New frequencies are valid. Press Next to continue.

You have entered new frequencies for which duplexer tuning is recommended.

**Current frequencies**

Transmitter frequency (MHz)      787.95  
 Receiver frequency (MHz)        757.05

**New frequencies**

New transmitter frequency (MHz)      
 New receiver frequency (MHz)       

Tx Raster test                            PASS

Rx Raster test                            PASS

Rx-Tx matching rasters                PASS

RF in-band test (757-788)            PASS

Duplexer sub-band test (757-788)   PASS

Tx-Rx (9 [MHz]) band split test     PASS

Skip shutdown and duplexer retuning

*Enter New Frequencies Page*

A warning appears that requests that the duplexers be re-tuned.

**6.5 POWER CALIBRATION**

The process for calibrating the transmitter power is described below.

The process for calibrating the power using CCMS is different from the process when using CLI in terms of what users can do. It is also a subject to constraints that the UI poses on the user.

The power meter should be connected to the Radio RF port that is to be calibrated via a 30dB 30W RF attenuator and the power meter should be configured with correct amplitude offset including the attenuation plus cable loss.

First select the **TX Power Calibration** from **Calibration** at the main menu. When done the following control is shown:

**Tx Power Calibration**

Press Start to initiate the Tx Power Calibration process. **Note that the transmitters will be turned off.**

Press **Start** to initiate the power calibration.

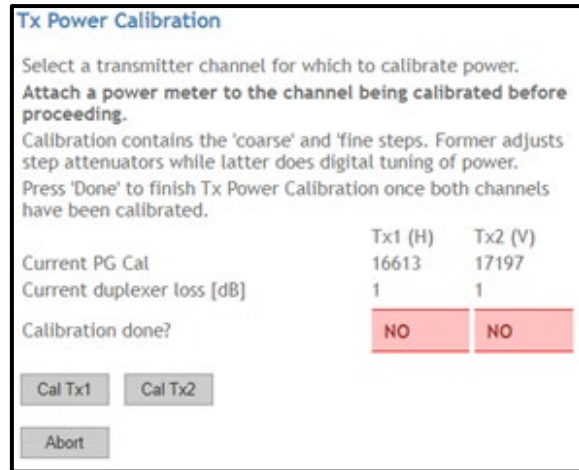

Proceed with **Cal Tx1** to calibrate the 1<sup>st</sup> transmitter or with **Cal Tx2** to calibrate the 2<sup>nd</sup> transmitter. These can be done in any order, but the following example will start with Tx1. The power at the current state is down and the carrier is turned **On** once one of these buttons is pressed.

### 6.5.1 CALIBRATING TX (COARSE STEP)

Once we press **Cal Tx1** the carrier power is turned on for transmitter 1 (transmitter 2 is Off) and user is ready to measure output power (uncalibrated output). The following page will allow to input the measured power and perform the 1st step of calibration (the coarse step),

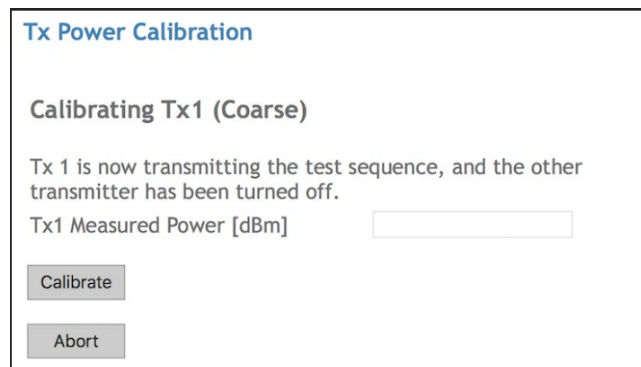

During this step, the duplexer loss in the RF EEPROM will be adjusted once **Calibrate** is pressed. This click will take the user to the 2nd calibration step, called the fine step.

### 6.5.2 CALIBRATING TX (FINE STEP)

The fine step is where the power is accurately adjusted using the PG - the digital gain and digital hardware method to control power. Click Calibrate on the following page to apply it,

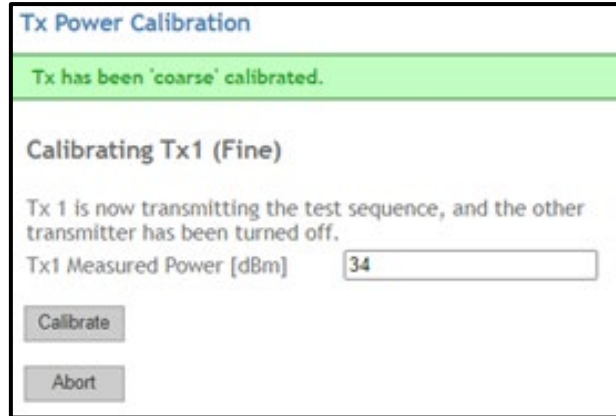

**6.5.3 COMPLETE CALIBRATION OF ONE TX**

Pressing **Calibrate** the 2nd time, finishes the adjustments and if successful, the following screen will be shown:

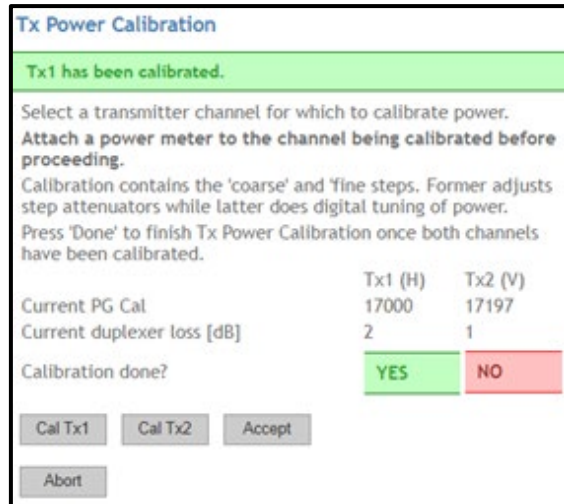

Users can abort the process at any time while still calibrating one of the Tx's by pressing the **Abort** button on this screen or on other process screens. The abort isn't permitted once both transmitters show a green YES on the last screen. This is one difference between CCMS and CLI: the CLI allows users to abort at any time unless you've already issued a confirm.

**6.5.4 COMPLETE BOTH TRANSMITTER CALIBRATION**

The next page shows up when both transmitters were successful in their calibration.

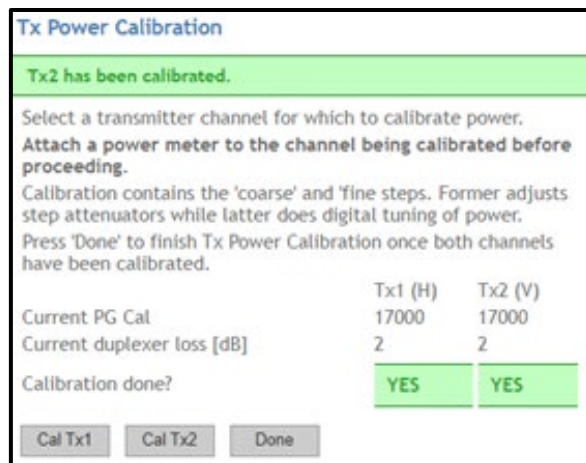

**6.5.5 TO FINISH POWER CALIBRATION, CLICK *DONE* CALIBRATION FAULT**

Sometimes, the calibration process can fail. This will occur if the PG is out of range at the fine step. The system checks the resulting PG against limits and the PG must be inside them for the calibration to pass. On failure of one of the transmitters the following page will be show:

**Tx Power Calibration**

**Tx1 has failed calibration! Pulse shaper gain was 8495. Abort**

Select a transmitter channel for which to calibrate power.  
**Attach a power meter to the channel being calibrated before proceeding.**  
 Calibration contains the 'coarse' and 'fine steps. Former adjusts step attenuators while latter does digital tuning of power.  
 Press 'Done' to finish Tx Power Calibration once both channels have been calibrated.

	Tx1 (H)	Tx2 (V)
Calibration done?	<b>NO</b>	<b>NO</b>

This will result in failure and user will need to abort by pressing the **Abort** button.

## 7 RSSI CALIBRATION

### 7.1 RSSI CALIBRATION

The Receiver RSSI may need be re-calibrated once the frequency of Transmitter and Receiver is swapped and the duplexer T/R end has been swapped.

A signal generator (analog) like Agilent E4432B or similar ones can be used for the RSSI calibration. And a 30dB attenuator (best to have 30W power handling) should be used in between the signal generator and the Radio RF port.

The RSSI and AGC control voltage are in linear relationship, as shown in formula 1.

$$\text{RSSI} = A \times \text{Vagc} + B \quad (1)$$

Where A represents the slope of the curve and B is the offset.

**NOTE:** The RSSI reading has an uncertainty of +/- 1.5dB

To find out A and B value we need two points (RSSI1, Vagc1) and (RSSI2, Vagc2), which are obtained by applying -40dBm and -60dbm signal at the receiver and recording the AGC voltage respectively.

RSSI calibration can be easily achieved by following the instructions step by step. Below is the summary of the procedure that is also shown on the RSSI Calibration page below (Calibration > RSSI Calibration).

1. Connect signal generator via a 30dB attenuator to Channel 1 RF port (receiver 1).
2. Set signal generator level so that -40dBm can be measured at the receiver input. Choose un-modulated carrier for the input signal.
3. Select Rx1 in the CCMS page.
4. Select -40dBm in the CCMS page.
5. Click Read in the CCMS page.
6. Set signal generator level so that -90dBm can be measured at the receiver input.
7. Select -60dBm in the CCMS page.
8. Click Read in the CCMS page.
9. Click Calculate in the CCMS page.
10. Set signal generator to -40dBm.
11. Click Calculate Offset in the CCMS page.
12. Click Save in the CCMS page.
13. Connect signal generator via a 30dB attenuator to Channel 2 RF port (receiver 2).
14. Repeat Step 2 to 12 for the Channel 2 receiver.
15. The following message will appear. Click **apply** to apply the new RSSI calibrations to the radio.

To apply the current changes please click the "Apply Changes" button on the "Control Panel" page or apply changes directly.

a.

**RSSI Calibration**

The calibration process for the RSSI:  
Calibrate to find two points A and B to create a RSSI curve using linear formula  $y=Ax+B$ .

1) Connect SigGen to a receiver.

**CAUTION! 30dB (>25W) power attenuator is recommended between the SigGen and the receiver as transmitter may operate and damage the SigGen.**

2) Set SigGen to obtain -40dBm and then -60dBm signal level at receiver, un-modulated carrier. While switching between receivers turn SigGen RF Off first and turn it on when cables are reconnected.  
First select -40dBm and press Read, then select -60dBm and press Read again before pressing Calculate!

3) Select receiver

4) Select input signal power

5) Click to read AGC value

AGC DAC Value (Lo)

AGC Digital DAC Value (Lo)

6) Repeat 4 and 5 for other power level when done for -40dBm.

7) Click to calculate

Calibration point A

Calibration point B

8) Set SigGen to obtain -40dBm at receiver, un-modulated carrier. Afterwards, press **Calculate Offset** to generate an RSSI offset from two readings.

Rx RSSI Reading (No Attenuation)

Rx RSSI Reading (Attenuation)

RSSI Offset

9) If all numbers look within range then click Save.  
This will save the values to the Configuration database.

10) Repeat for next receiver channel.

RSSI Calibration Page

## 7.2 REFERENCE CALIBRATION

For the radio to maintain an accurate frequency reference calibration of the radio's frequency reference is recommended to be checked after three years. This is only necessary on BRU and NDL units, RRU units lock their reference to the connected base. Because of this, this page is inaccessible on RRU units.

### 7.2.1 EQUIPMENT REQUIRED FOR REFERENCE CALIBRATION

- An accurate 10 MHz source is needed, with a level between -5 and +20 dBm
- A Mimomax GPIO/Ref/Alarm cable
- A connection to the radios CCMS

### 7.2.2 HOW TO CALIBRATE THE REFERENCE

1. Feed the 10 MHz source into the reference inputs of the GPIO/Ref/Alarm connector (Brown and Red wires on the Mimomax GPIO/Ref/Alarm cable). Note: the reference signal is differential, but it does not normally cause any problems if a non-differential signal is used, treat one of the differential connections as ground in this case.
2. In CCMS, navigate to 'Calibration' > 'Reference Calibration'.
3. Click 'Start'.

If the calibration is successful the message, 'A 10 MHz reference has been found. The calibration process was successful' will be displayed.



## Reference Calibration

Attach the 10MHz reference to the external reference input.

An accurate 10MHz source is needed, with a level between -5 and +20 dBm.

Use pins 2 and 3 of the GPIO/REF/ALARM connector.

Press Start to start the reference calibration process ...

Start

*Reference calibration*

## 8 RADIO REFERENCE INFORMATION

### 8.1 MECHANICAL DIMENSIONS AND MOUNTING

This section describes the dimensions of the Tornado radio unit and the various methods of mounting.

#### 8.1.1 DIMENSIONS

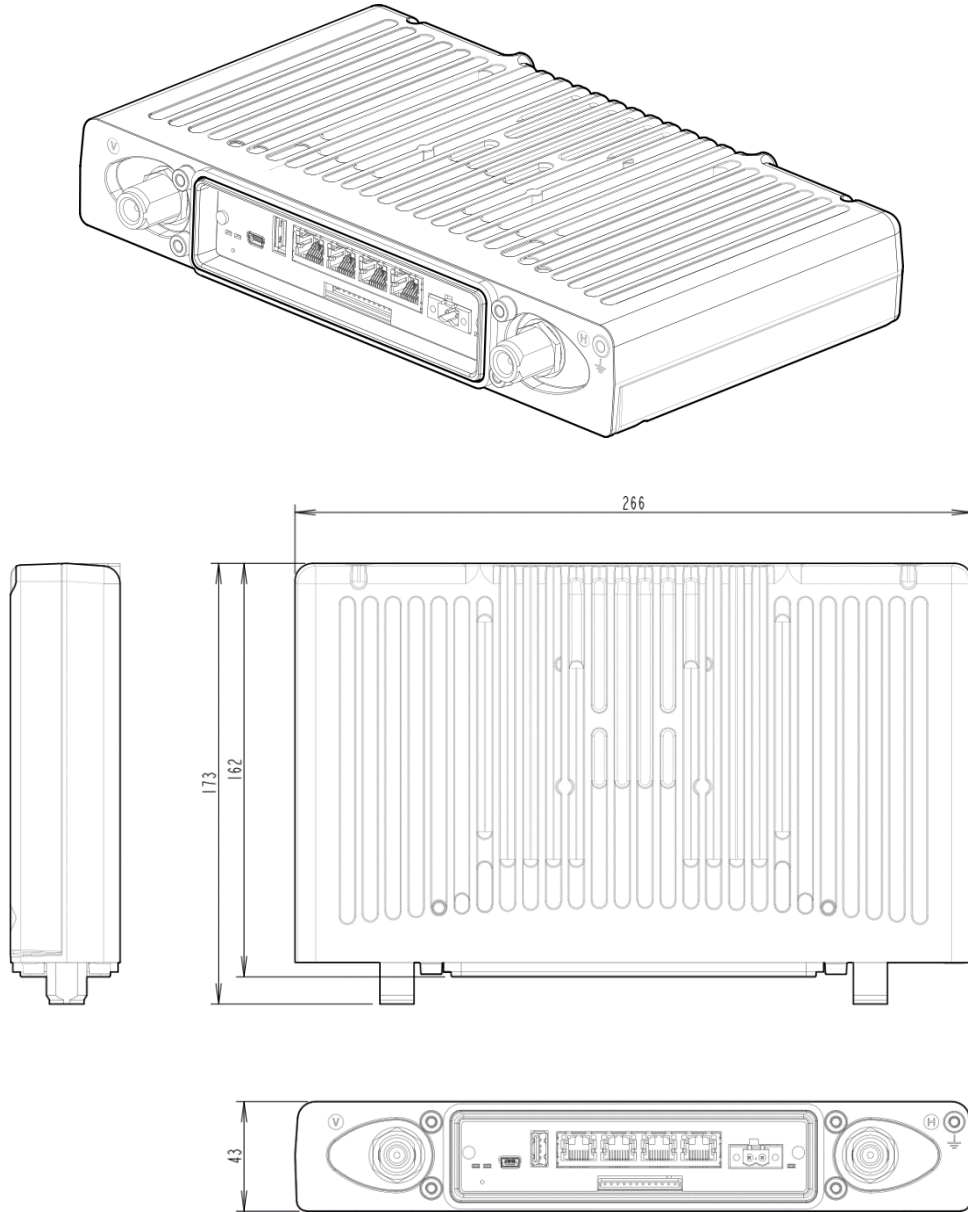

*Mechanical Dimensions for Tornado XR (All units are in mm)*

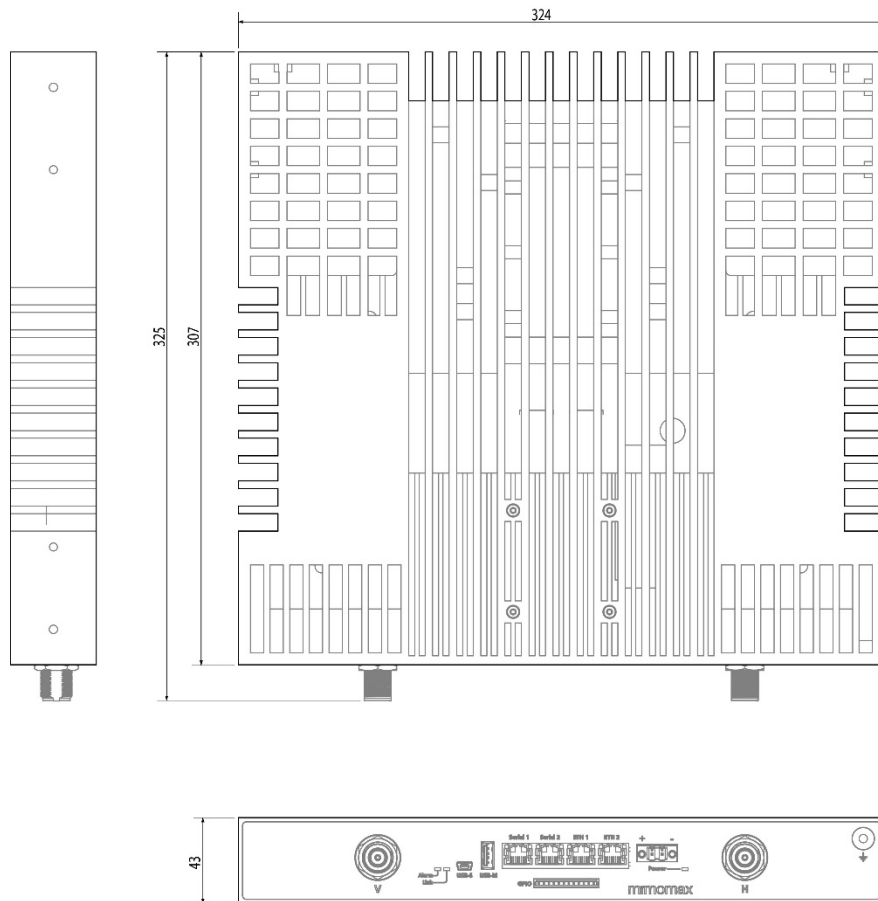
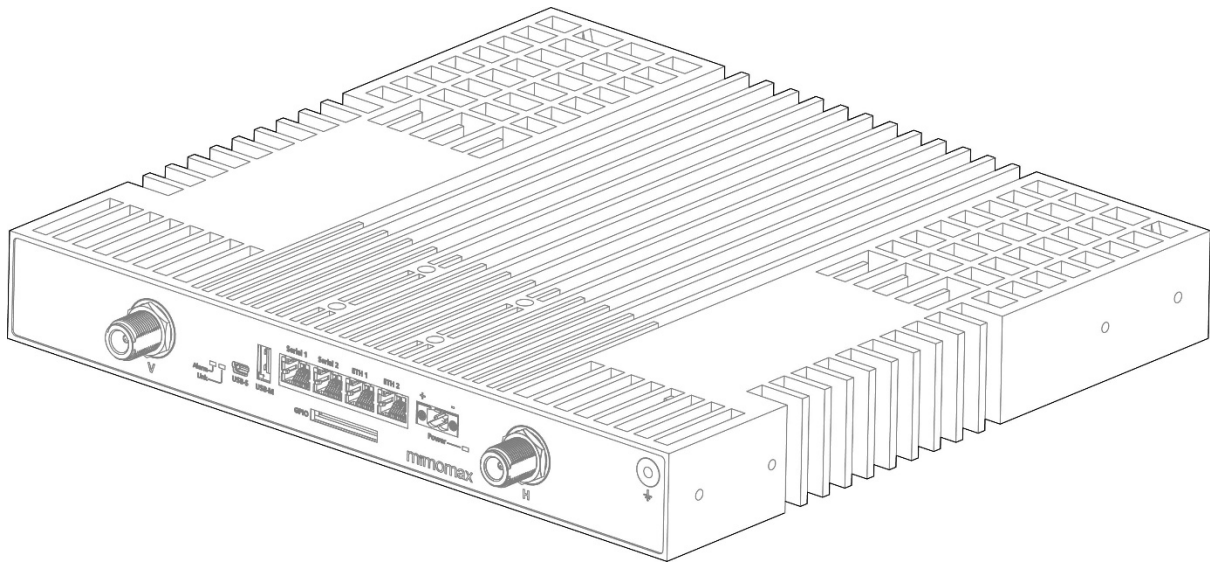

*Mechanical Dimensions for Tornado X (All units are in mm)*

### 8.1.2 MOUNTING

The radio unit can be mounted in Rack, Pole, Wall or DIN mount configurations. Each of these styles of mounting can be further customised further by collocating or separating aspects such as batteries and power supplies. There are advantages and disadvantages for each scenario.

### 8.1.2.1 Rack Mount

The Rack mount kit is designed to be used to mount the Tornado X and Tornado XR into a standard 19" rack enclosure, occupying 1U of rack height. Tools required are a #2 Philips screwdriver.

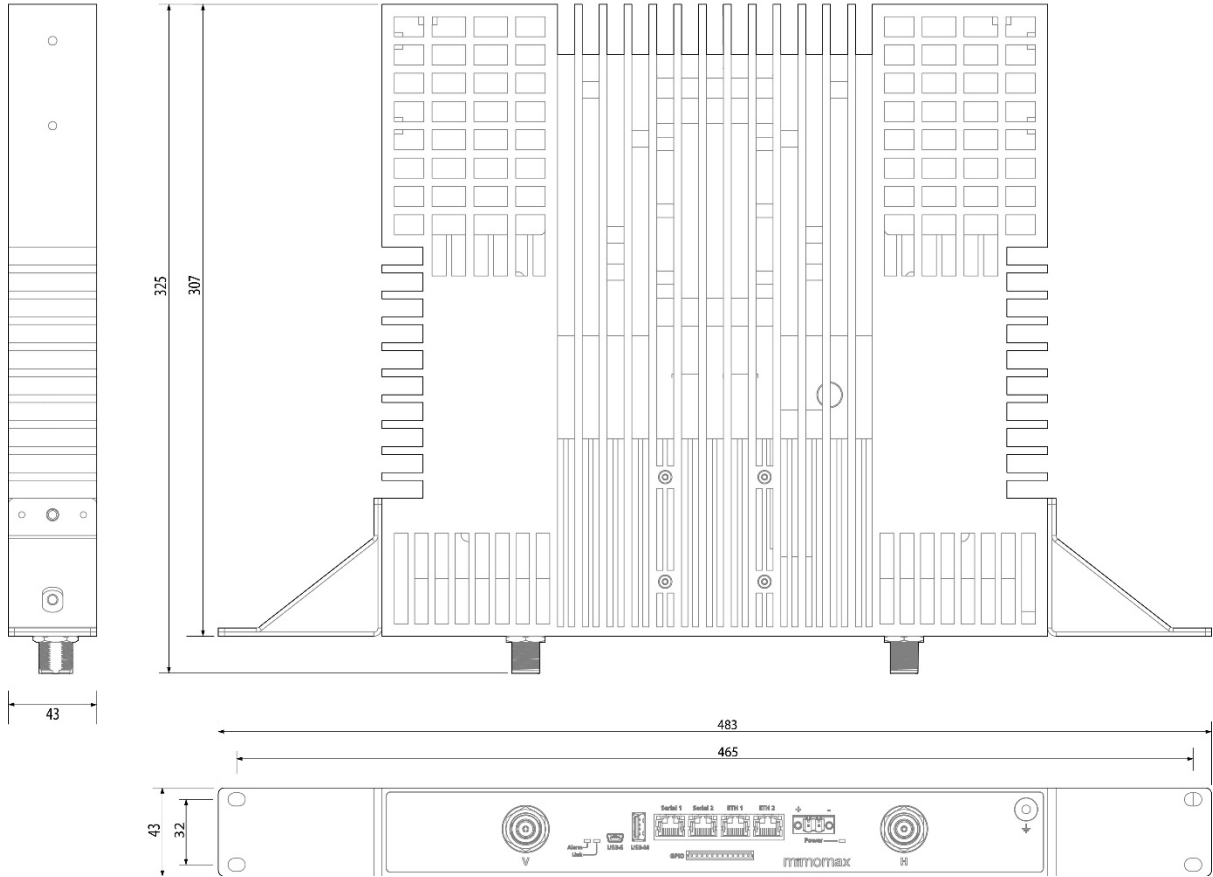

*Mechanical Dimensions for Tornado X with mounting brackets (All units are in mm)*

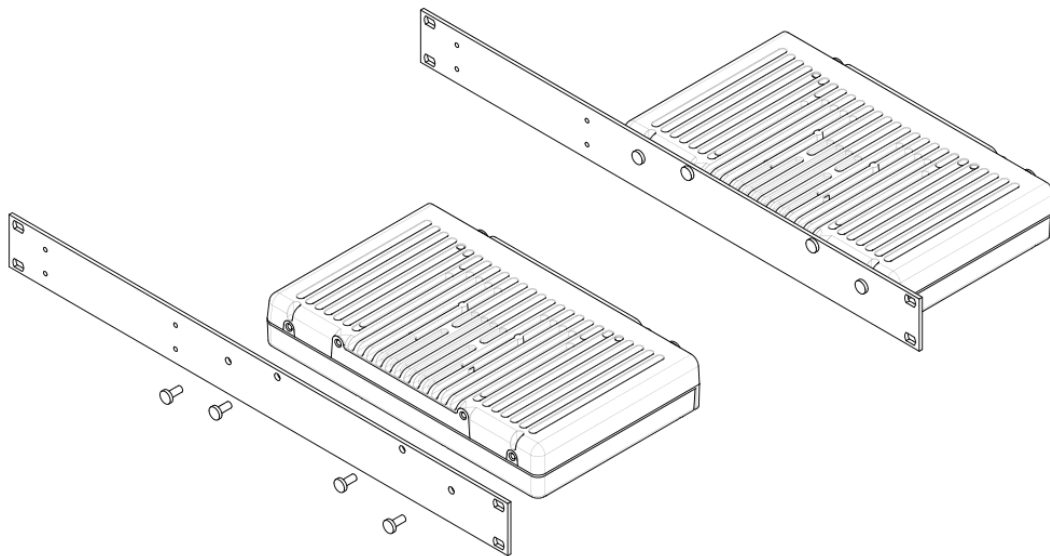

*Assembled and exploded view of the Tornado XR rack mount*

### 8.1.2.2 Pole Mount

The pole mount kit can be used to mount the tornado onto a pole with a diameter between 23 and 51 mm. If the tornado is mounted outside, then the weatherproof hood must be used. Tools required are a #2 Philips screwdriver and a 10 mm spanner.

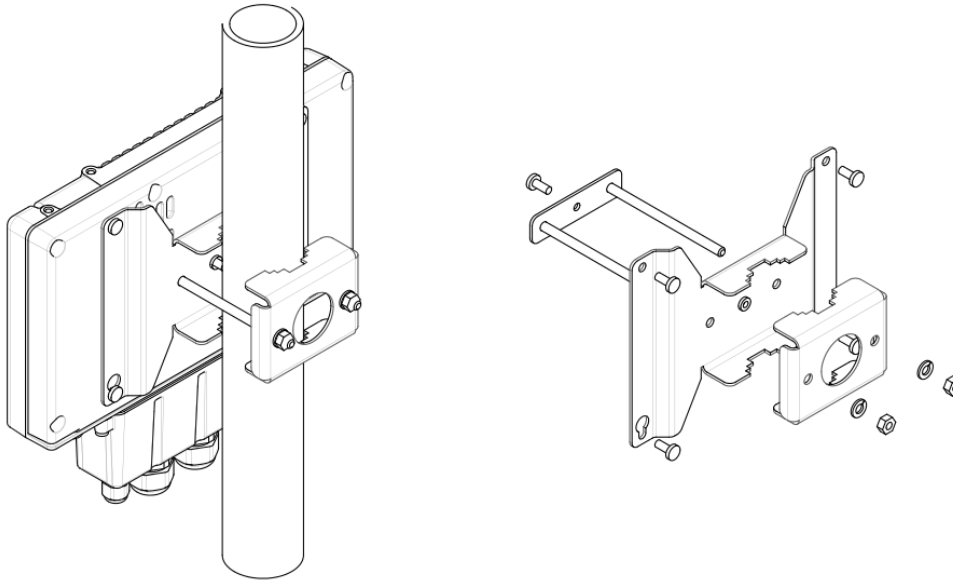

*Assembled and exploded view of the Tornado XR pole mount*

### 8.1.2.3 Wall Mount

The wall mount kit can be used to mount the Tornado XR to an existing structure, or even to a large diameter wooden pole. If the Tornado is mounted outside, then the weatherproof hood must be used.

Tools required are a #2 Philips screwdriver, and R2 square drive. The supplied wall screws are of 'Walldog' type. They do not require a drill bit for wood, but a 5mm drill bit will be required to insert the mounting screws into concrete, brick or stone. A 5.5mm masonry bit may be required for especially hard material.

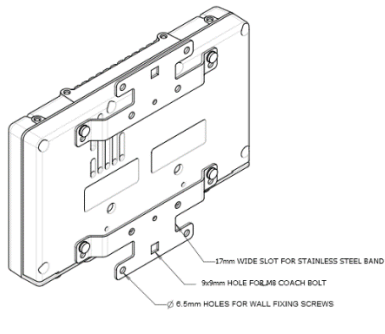

*Assembled and exploded view of the Tornado XR wall mount*

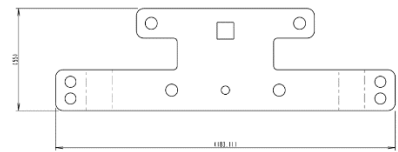

*Tornado XR Wall mount dimension (in mm)*

**8.1.2.4 DIN mount**

The Tornado can also be mounted to a Top hat style DIN rail (EN 50022). Tools required are a #2 Philips screwdriver.

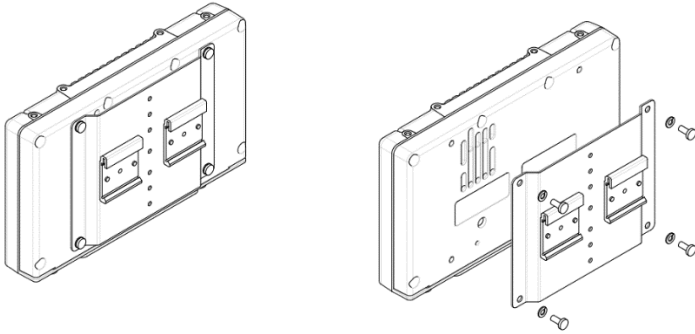

*Assembled and exploded view of the Tornado XR DIN mount*

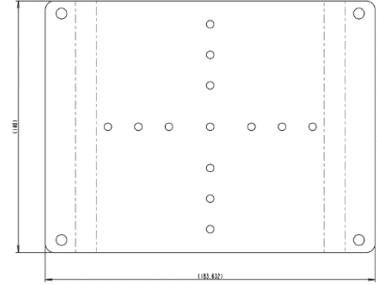

*Tornado XR DIN mount dimension (in mm)*

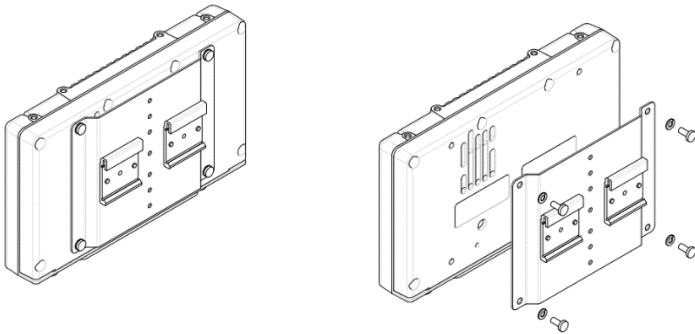

*Assembled and exploded view of the Tornado XR DIN mount*

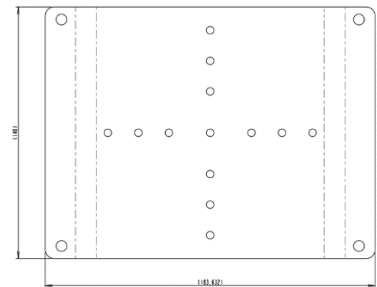

*Tornado XR DIN mount dimension (in mm)*

**8.1.2.5 Weatherproof hood**

The weatherproof hood can be used to protect the Tornado XR interfaces from dust or moisture ingress. It needs to be used whenever the unit is mounted in an outdoor environment or in adverse conditions.

When installing the hood, orientate it so that the power label on the hood is on the same side as power label on the radio unit. Do not over tighten the screws or glands. The Tornado XR then is to be mounted vertically with the glands oriented downwards, as seen below.

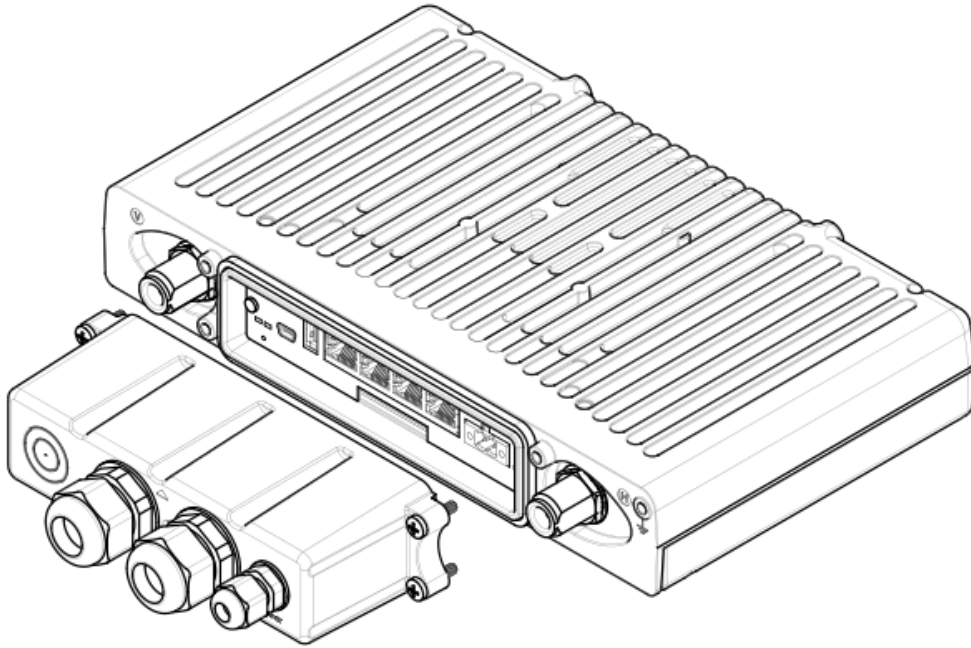

*Exploded view of the weatherproof hood*

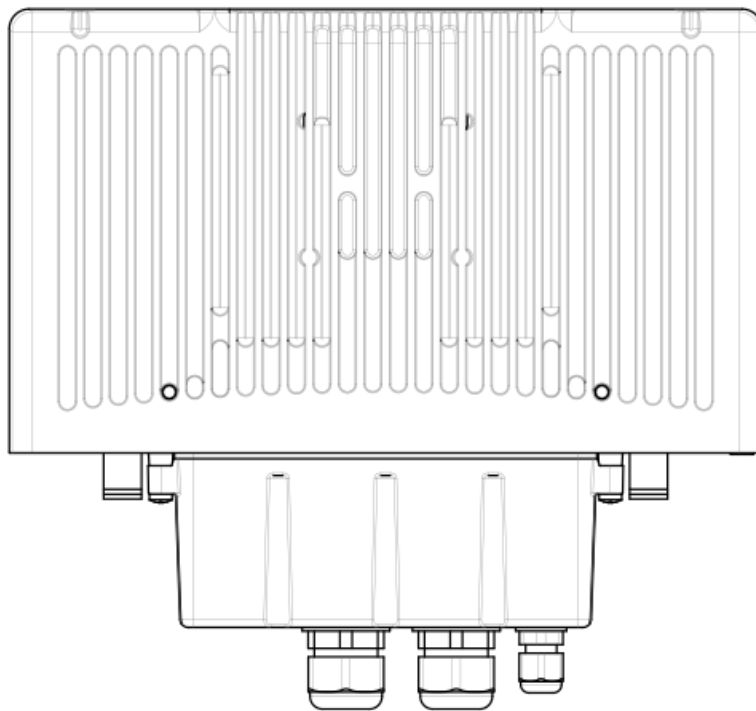

*Mounting orientation of the weatherproof hood*

#### **8.1.2.6 Mounting holes**

If other mounting options are desired, the mounting holes described as shown below can be used directly. Ensure that bolts of the correct diameter and depth are used, otherwise damage may occur.

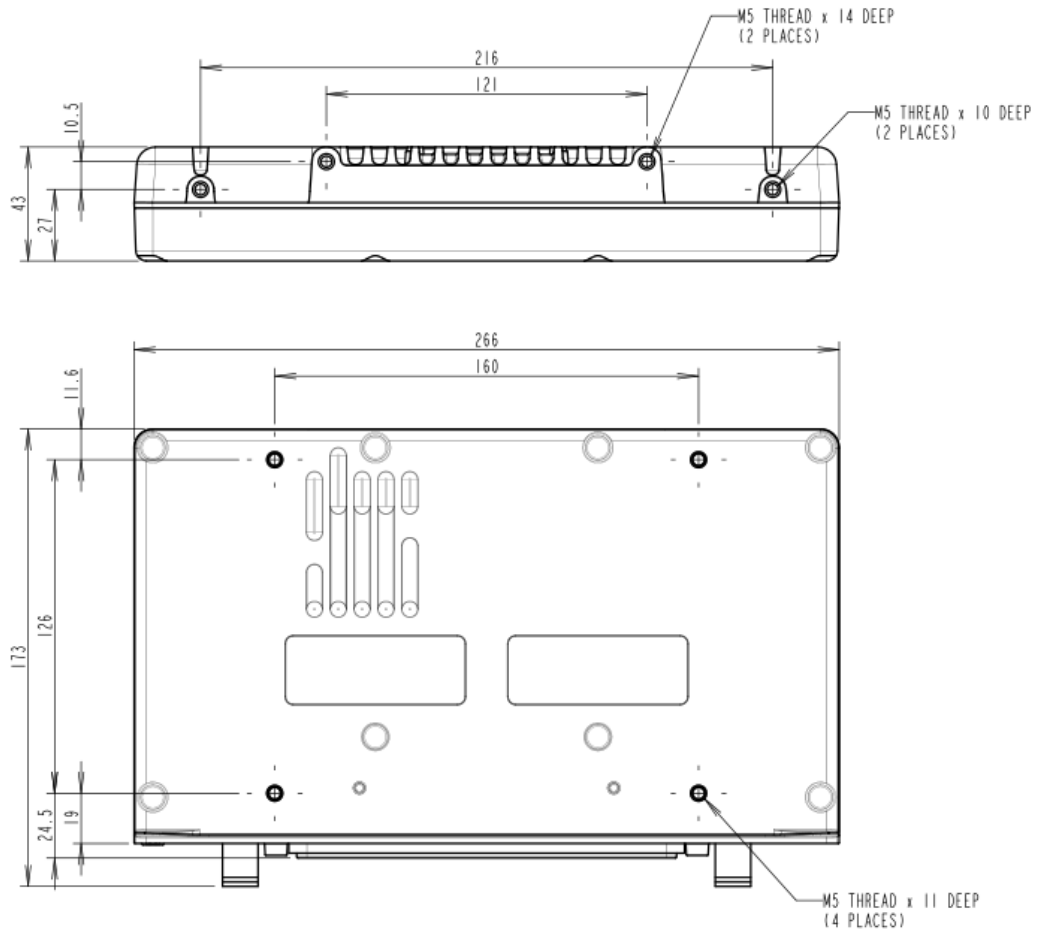

*Mounting hole size, depth and location*

## 8.2 INPUT AND OUTPUT

This section describes the general I/O of the device. It includes an overview of all connectors as well as LED's and other relevant electrical parameters. Refer to the Tornado serial manual for detailed information on the use of the serial interfaces.

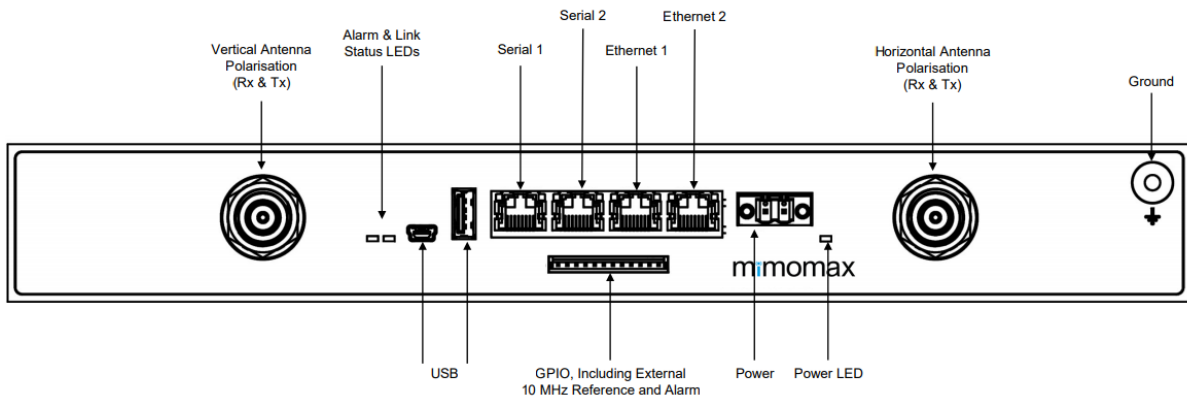



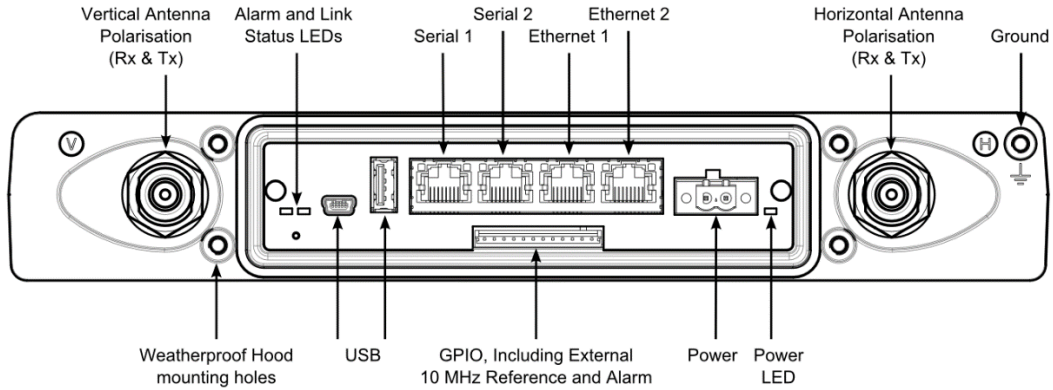

### Radio Connections and LEDs

#### 8.2.1 CONNECTORS

##### Antenna/Duplexer ports (2x N connectors)

The radio unit is a 2x2 MIMO unit with internal duplexers. This means each N connector is both a transmit and a receive port. In order to aid in diagnostics, the left port should be connected to the vertical antenna polarisation while the right port is connected to the horizontal polarisation.

*Be careful that feeders connected to the N connectors are not over tightened.*

##### Ethernet

Two shielded RJ45 sockets provide the Ethernet connection(s). Shielded cable is not normally required.

##### Serial

Two shielded RJ45 sockets provide serial port connection.

##### Power connector

A Phoenix Contact MSTB 2, 5 HC connector provides the Power Connection.

##### GPIO

A JST S12B-EH connector has the GPIO, Alarm and Reference connections.

##### Earth

A chassis earth point is provided.

##### USB host (USB-M)

An A-type USB connector provides the connection to the USB host port (software support will be developed in the future).

##### USB device (USB-S)

A mini B type USB connector provides the connection to the USB device port (software support in future).

#### 8.2.2 LED BEHAVIOUR

##### Power LED (Green)

The power LED is located on the right of the front panel. The LED lights up when power is applied.

##### Link LED (Green)

**NDL:** The Link LED lights up when an RF link is active.

**RRU:** The Link LED has four different modes of operation each indicating a different RF link state. It is off when the RRU is not detecting a signal from the BRU. It will flash with a 50 percent duty cycle at 1 Hz when the radio is synchronised with the BRU. A pattern of two flashes followed by a gap will repeat at 1 Hz once a downlink is established. And finally, it will be constantly on once a full duplex link is established.

**BRU:** The Link LED operates with a time out of approximately two minutes. Every time communication occurs between the BRU and one of its RRUs the timer will reset. Regular communication between the units will be indicated by this LED remaining on.

### Alarm LED (Red)

During boot up (proximally 10 seconds after power is applied) the LED will flash at a rate of 1Hz to indicate that the radio is in its boot up process.

Once boot up is complete, the LED will flash when the radio is in an Alarm state.

### Ethernet LEDs

Each Ethernet port has a green and an orange LED. The green LED flashes when the port is receiving data. The orange LED is off when the port is 10 Mbit/s and on when it is 100 Mbit/s.

## 8.2.3 ESSENTIAL POWER REQUIREMENTS

### 8.2.3.1 Voltage Range

The operating input voltage range of the power supply is 10.5 to 60 VDC. This means that the voltage must not rise above 60 VDC under idle conditions or fall below 10.5 VDC at full load.

### 8.2.3.2 Static Power Input

The typical power drawn when the transmitter is active is about 67.5W (maximum 73.5W). This occurs when the two transmitter channels are operating at full power.

**Note:** this assumes a 100% transmitter duty cycle as produced by the Base station radio. For the Remote radio, the duty cycle is 25% and the typical power drawn values become about 22.5W (maximum 28.5W) respectively.

The power drawn via the internal switching regulators is nearly independent of supply voltage, except for some additional converter loss at the top end of the voltage range, so that the input current to the RU is almost inversely proportional to supply voltage, e.g. approximately 8.1A at 10.5V or 1.5A at 56V. This needs to be considered when the power source is remote from the RU and cable loss is a factor.

Input Source Voltage (S)	Average Current in Amperes = $I_{avg} = 67.5/S$	Circuit Breaker Current in Amperes = $I_{mcb} = 1.5 \cdot I_{avg}$
10.5 Volts	6.4 Amps	12.1 Amps
24 Volts	2.8 Amps	5.2 Amps
48 Volts	1.4 Amps	2.7 Amps
56 Volts	1.2 Amps	2.2 Amps

Table 1: Current draw assuming 100% Transmitter Duty cycle and 80% Efficiency of Power Supply

Input Source Voltage (S)	Average Current in Amperes = $I_{avg} = 22.5/S$	Circuit Breaker Current in Amperes = $I_{mcb} = 1.5 \cdot I_{avg}$
10.5 Volts	2.1 Amps	2.4 Amps
24 Volts	0.9 Amps	1.1 Amps

48 Volts	0.5 Amps	0.6 Amps
56 Volts	0.4 Amps	0.5 Amps

*Table 2: Current draw assuming 20% Transmitter Duty cycle and 80% Efficiency of Power Supply*

### 8.2.3.3 Starting Current

As long as the power supply can supply the static power it should be able to provide sufficient current during start-up.

### 8.2.3.4 Supply Polarity (Isolated Power Supply)

In the Base station radio, both the positive and negative connections of the power supply are isolated from the case and other circuitry. This is not so for the Remote radio which has a non-isolated power supply.

The standard DC power cable supplied with an RU is twin 1.5mm (16AWG), approximately 2m long, terminated at the RU end with a Phoenix Contact MSTB 2,5 HC plug. This cable is wired to pins 1 (positive) and 2 (negative) of the plug, which employs screw terminal contacts.

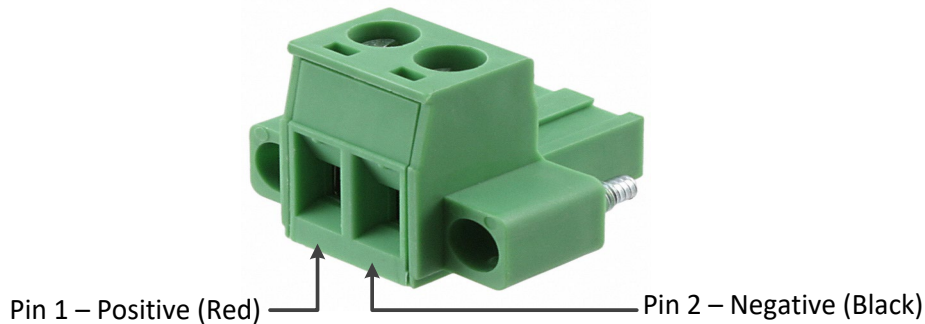

*Power supply connector*

### 8.2.3.5 Grounding

The radio unit case must be grounded through an external earth strap. Generally, this is done to the local rack frame, which in turn should be part of a well-designed station grounding system. This internal grounding is designed for EMC and transient protection currents. The RU casting is tapped to take a M4 x 8mm screw for grounding purpose.

### 8.2.3.6 Supply Noise

Regardless of the EMC provisions in the equipment, power wiring from the DC source should not be shared with other equipment that may introduce excessive noise. Nor should the power cables to the RU be run alongside cables that connect to other equipment that may produce high current noise or transients, e.g. power relays.

### 8.2.3.7 Operating from AC Mains:

AC-DC 'desktop' power supplies are available from Mimomax with the required power.

### 8.2.3.8 Choice of power supply cable size

The table below indicates the maximum length of cable that can be used for given supply voltages and cable sizes. It also includes the maximum loop resistance, so that other combinations can be checked.

Cable length was calculated for 80% power transfer efficiency (or 10.5 volts at the radio, in the case of a 12V supply) with a 68-watt load and supply  $V_{min}$ . The value used for resistivity of copper was at 70 Celsius. This table is a guide only. Always check the cable manufactures data before detailed engineering.

Supply voltage

<b>Cross sectional area (mm<sup>2</sup>)</b>	<i>Approx. AWG</i>	<b>12V</b> (Vmin = 11V)	<b>24V</b> (Vmin = 18V)	<b>48V</b> (Vmin = 36V)
<b>1.85</b>	14	3.5m	55m	175m
<b>2.5</b>	13	4.5m	75m	
<b>4<sup>1</sup></b>	10	7.2m		
<b>6<sup>1</sup></b>	8	11m		
<b>Max loop resistance</b>		0.06 Ω	1.0 Ω	3.2 Ω

*Table 3: Recommended maximum cable length for a given supply cable size*

Note 1: The Phoenix Contact MSTB 2,5 HC plug can support stranded wire with a cross sectional area between 0.2 mm<sup>2</sup> and 2.5 mm<sup>2</sup>. Longer cable runs will therefore need to use a distribution block, and cable with a smaller size for the final connection.

**ELECTRICAL CHARACTERISTICS**

<i>Parameter</i>	<i>Conditions</i>	<i>Min</i>	<i>Typical</i>	<i>Max</i>	<i>Units</i>
<b>Power supply</b>					
Input voltage	Normal operation	10.5		60	V
Power Consumption	Idle, Tx off		5.5	7.6	W
Power Consumption(Tornado X)	Tx Active 100%		67.5	73.5	W
Power Consumption(Tornado XR)	Tx Active 25%		22.5	28.5	W
<b>Ethernet</b>					
Tx Peak Differential voltage	100Base-Tx, 100 Ohm termination		1.00	1.05	V
Tx voltage imbalance	100Base-Tx, 100 Ohm termination			2	%
Tx Rise/Fall time	100Base-Tx	3		5	ns
Tx Rise/Fall imbalance	100Base-Tx	0		0.5	ns
Tx duty cycle distortion	100Base-Tx			+/- 0.5	ns
Tx Overshoot	100Base-Tx			5	%
Tx Output Jitter	100Base-Tx, Peak to Peak		0.7	1.4	ns
Tx Peak Differential voltage	10Base-T, 100 Ohm termination		2.4		V
Tx Output Jitter	10Base-T, Peak to Peak		1.4	11	ns
Rx Squelch Threshold	10Base-T, 5MHz square wave		400		mV
<b>Serial</b>					
Output Voltage swing	Loaded with 3kOhms to ground	+/- 5	+/- 5.4		V
Output short circuit current		-60		+60	mA
Input Voltage		-25		+25	V
Input Low Threshold	Temperature ambient = +25	0.8	1.5		V
Input High Threshold	Temperature ambient = +25		1.8	2.4	V
5VPC Output Current	200			200	mA
<b>GPIO</b>					
Input voltage	Input	-0.3		60	V

Current Sinking Capability	Output driving low		100	mA
Input Impedance			109	kOhms
<b>Alarm</b>				
Input current (max)			300	mA
Switching voltage (max)			33	VDC
<b>Reference input</b>				
Level		-5		+20 dBm
Frequency			10	MHz
<b>Reference output</b>				
Level			0	dBm
Frequency			10	MHz
<b>USB Host</b>				
VBus Output Current			400	mA
Input voltage	Voltage on Dm and Dp pins	-0.3		5.25 V
<b>USB Device</b>				
Input voltage	Voltage on Dm and Dp pins			5.25 V
Vbus	Voltage on VBus pin			5.5 V

Table 4: Electrical characteristics

## 8.2.4 INTERFACE PORTS

The radio unit has Ethernet and asynchronous serial interfaces as well as a General-Purpose Input/Output (GPIO). The GPIO connector incorporates an alarm and external reference. Various synchronous serial standards are also supported via external converter boxes. The serial pin out is briefly described in this document. Please refer to the Tornado serial manual for detailed information on configuring the unit's serial interfaces.

### 8.2.4.1 Ethernet

The radio unit has dual 10/100Base-Tx ports which are connected to the CPU via a managed switch. The ports support auto MDI-X, auto negotiation, half & full duplex operation and flow control. These parameters can be configured in the network section of CCMS.

### 8.2.4.2 Asynchronous Serial (RS232)

The Tornado RS232 pin out is as per the EIA/TIA – 561 standards. Note: this is different to older Mimomax products.

Signal Name	Pin number	Direction
Tx Data	6	In to radio
Rx Data	5	Out of radio
CTS	7	Out of Radio
RTS	8	In to Radio
Ground	4	n/a
5VDC	1	Out of Radio

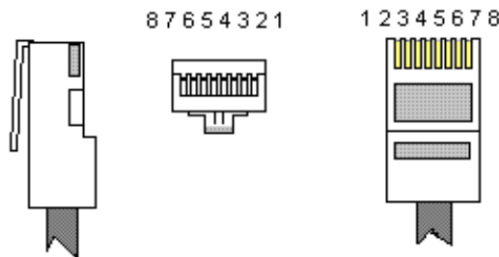

### 8.2.4.3 GPIO/Alarm/REF

The GPIO alarm and reference in/out signals are available via a 12-pin connector on the front of the tornado (see GPIO Connector below). A complete cable loom is available from Mimomax, or alternatively the female connector required is a JST HRP-12-S. For pinouts see Table 4: GPIO pin out.

Configuration of the GPIO should be performed using CCMS. See System > User GPIO for more information.

- The alarm provides both open and closed in alarm contacts and is isolated from the rest of the radio circuitry.
- The External reference input/output is an isolated differential pair.

GPIO as analog input:

- The GPIO signals are all referenced to the Radio ground. Their linear range is 0-12V, but they will survive up to 60V. An external series resistor can be used to provide a higher linear range using the following formula.

$$R_{ext} = (V_{max} - 12) * 109k / 12$$

- Where  $V_{max}$  is the maximum voltage that will be measured, 109k is the input impedance, and  $R_{ext}$  is an external series resistor between the voltage being measured and the tornado GPIO pin. Remember to round the resistor value up to the nearest resistor value above the calculated value.

- Next use the GPIO input calibration process to calibrate the system through the external resistor. This process will be based on a known voltage before the resistor.

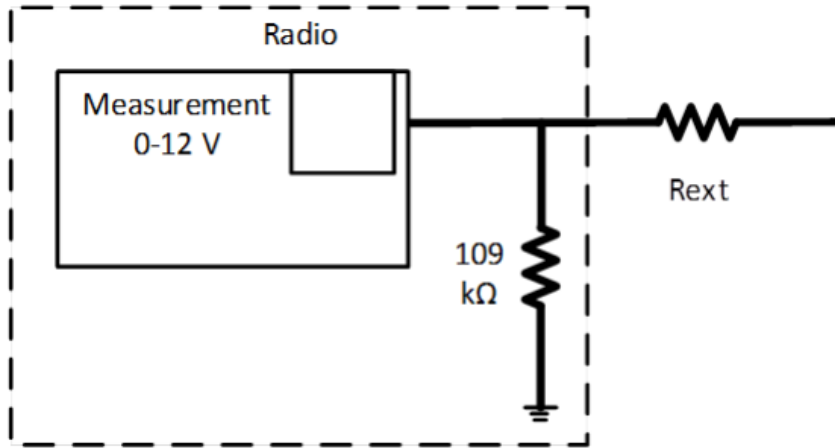

*GPIO Input Circuit*

GPIO as digital output:

- The GPIO pins provide an open collector output, which can be used to drive a relay or generate a level. The current can be up to 100 mA.

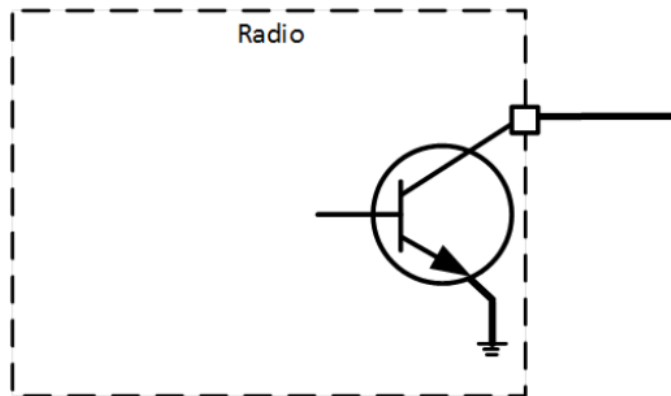

*GPIO Output Circuit*

Signal Name	Pin number	Colour on Mimomax cable
Not Connected	1	n/a
Ext Ref n	2	Brown
Ext Ref p	3	Red
GPIO Ground (Radio Ground)	4	Orange
GPIO_4	5	Yellow
GPIO_3	6	Green
GPIO_2	7	Blue
GPIO_1	8	Violet
Open in Alarm	9	Grey
Alarm Comm	10	White



Closed in Alarm	11	Black
Not Connected	12	n/a

Table 5: GPIO pin out

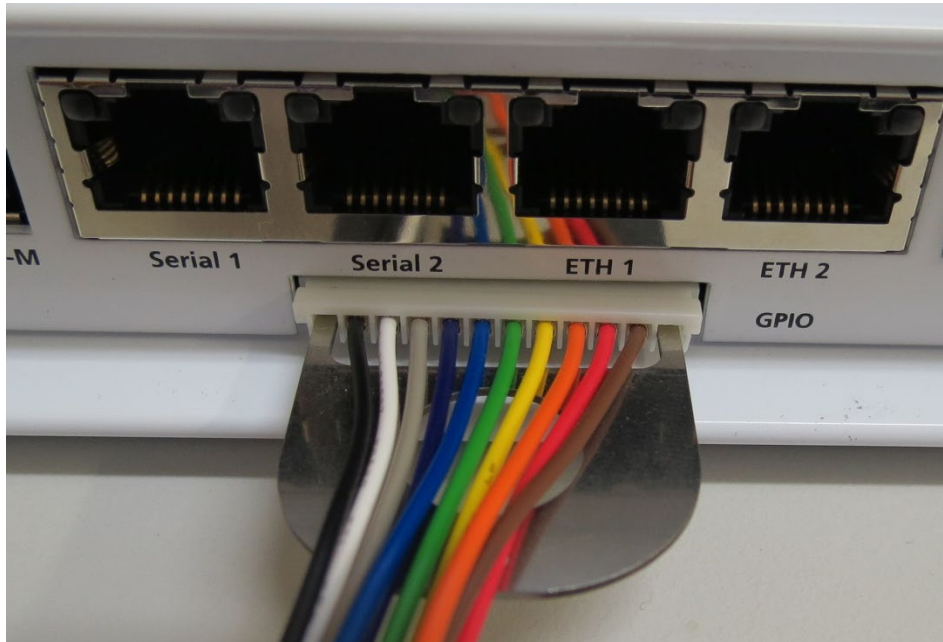

GPIO Connector

## 8.2.5 RF SPECIFICATION

### General

Configuration	2x2 MIMO	
Connector type	N-Type, 50 Ohms	
Ambient Temperature Range	-30°C to +60°C Horizontal mount, all products or -30°C +70 °C for a vertically mounted RRU	
Base Gross Data Rate (QPSK)	50 kHz	160 kbps Full-duplex
	25 kHz	80kbps Full-duplex
	12.5kHz	40kbps Full-duplex
Upgradable Gross Data Rate (16/64/256 QAM)	50 kHz	320/480/640 kbps Full-duplex
	25 kHz	160/240/320kbps Full-duplex
	12.5kHz	80/120/160kbps Full-duplex
Available Data Rate (QPSK/16/64/256 QAM)	50 kHz	132/262/410/548 kbps Full-duplex
	25 kHz	66/132/197/262 kbps Full-duplex

	12.5 kHz	33/66/98/131 kbps Full-duplex	
<b>Receiver</b>			
Modulation		QPSK/16/64/256QAM	
Number of MIMO Receivers		2	
Symbol Rate	50 kHz	2x40k symbols/sec	
	25 kHz	2x20k symbols/sec	
	12.5	2x10k	symbols/sec
Modulation sensitivity <sup>1</sup> for 10 <sup>-4</sup> BER	50 kHz	-111/-104/-98/-91 dBm	
	25 kHz	-114/-107/-101/-94dBm	
	12.5kHz	-117/-110/-104/-97dBm	
Modulation sensitivity <sup>1</sup> for 10 <sup>-7</sup> BER	50 kHz	-109/-102/-96/-89	dBm
	25 kHz	-112/-105/-99/-92dBm	
	12.5kHz	-116/-108/-102/-96dBm	
Frequency Range		757 to 758 and 787 to 788 MHz	
Frequency Step Size		5kHz & 6.25 kHz selectable	
Nominal Channel Bandwidth		12.5kHz, 25 kHz and 50kHz	
Maximum Signal Level		-10dBm/QPSK	
Absolute Maximum Input Level		+20dBm	
<b>Transmitter</b>			
Number of MIMO Transmitters		2	
Nominal load impedance		50 Ohms	
		Require better than 1.5:1 VSWR (-14 dB return loss)	
Modulation		QPSK/16/64/256QAM	
Symbol Rate	50 kHz	2x40 k symbols/s	
	25 kHz	2x20 k symbols/s	
	12.5kHz	2x10 k symbols/s	
RF Power Output		2 x +34 dBm average +/-1.5 dBm, (+2/-3 at Extreme Temp.)	

RF Power Control Range	>20 dB
RF Power Control Resolution	0.5 dB
Frequency Range	757 to 758 and 787 to 788 MHz
Frequency Accuracy and Stability	Better than +/-1 ppm

---

**Transmitter (continued)**

Adjacent Channel Power Ratio (ACPR)	>60 dB
Transient ACPR	>60 dB
Intermodulation Rejection	>70 dB
Tx Occupied BW	50 kHz    42 kHz
	25 kHz    21.1 kHz
	12.5 kHz    10.3 kHz

---

**Internal Duplexer**

Type	Bandpass
Tx/Rx Split	30 MHz (700 MHz)
Frequency Range	, 757-758MHz, 787-788MHz
Stop Band Attenuation	>75 dB (700 MHz)
Pass Band Bandwidth	3 MHz (-0.5 dB) (700MHz)

---

1. Sensitivity as specified includes forward error correction and internal duplexer loss. Note that systems employing adaptive modulation (e.g MDL or MCAM) will automatically reduce the modulation order at a signal level higher than the specified sensitivity level. This will maintain the lowest possible error rate.

*Table 6: RF characteristics*

### 8.2.5.1 Site Engineering

**For personal safety and equipment reliability reasons the following must be adhered to:**

#### Power supply

The equipment must be powered from a power supply complying with the requirements of IEC 60950-1 including compliance with sub clause 7.4 'Insulation between primary circuits and cable distribution systems'.

#### Grounding

On site ground networks must be created in accordance with ITU-T Recommendation K.27: Protection against Interference; Bonding Configuration and Earthing inside a telecommunications building.

### Equipment location

It is recommended that the radio unit is installed in a dry, dust-free room. If this is not possible then the waterproof boot must be fitted to protect the unit.

### Equipment ventilation

A thermal study should be carried out for each site to check and ensure that thermal conditions within the enclosures do not go beyond the radio units operating limit. If the temperature of the site is known to exceed the operating limits of the unit, then the enclosure must have an air conditioning, or a forced air system installed to stabilise these excursions.

### Lightning protection

Lightning protection is important to ensure the protection of the tower, antenna and the radio equipment hardware. Below shows the point earthing concept recommended.

The technique recommended to protect the radio unit, antenna, feeder and tower uses earthing kits in strategic places. The key points are: adjacent to the feeder connector at the antenna, where the feeder leaves the base of the tower and where the feeder enters the building structure. If earthing kits supplies are limited or connection to an earth point is difficult, then order of importance of the earthing locations is as follows:

- (a) For a top mounted antenna acting for lightning protection:
  - 1. At antenna connection point.
  - 2. At the tower base.
  - 3. At the entry to the building.
- (b) For a general mounting of antenna:
  - 1. At the entry to the building.
  - 2. At the tower base.
  - 3. At the antenna connector.

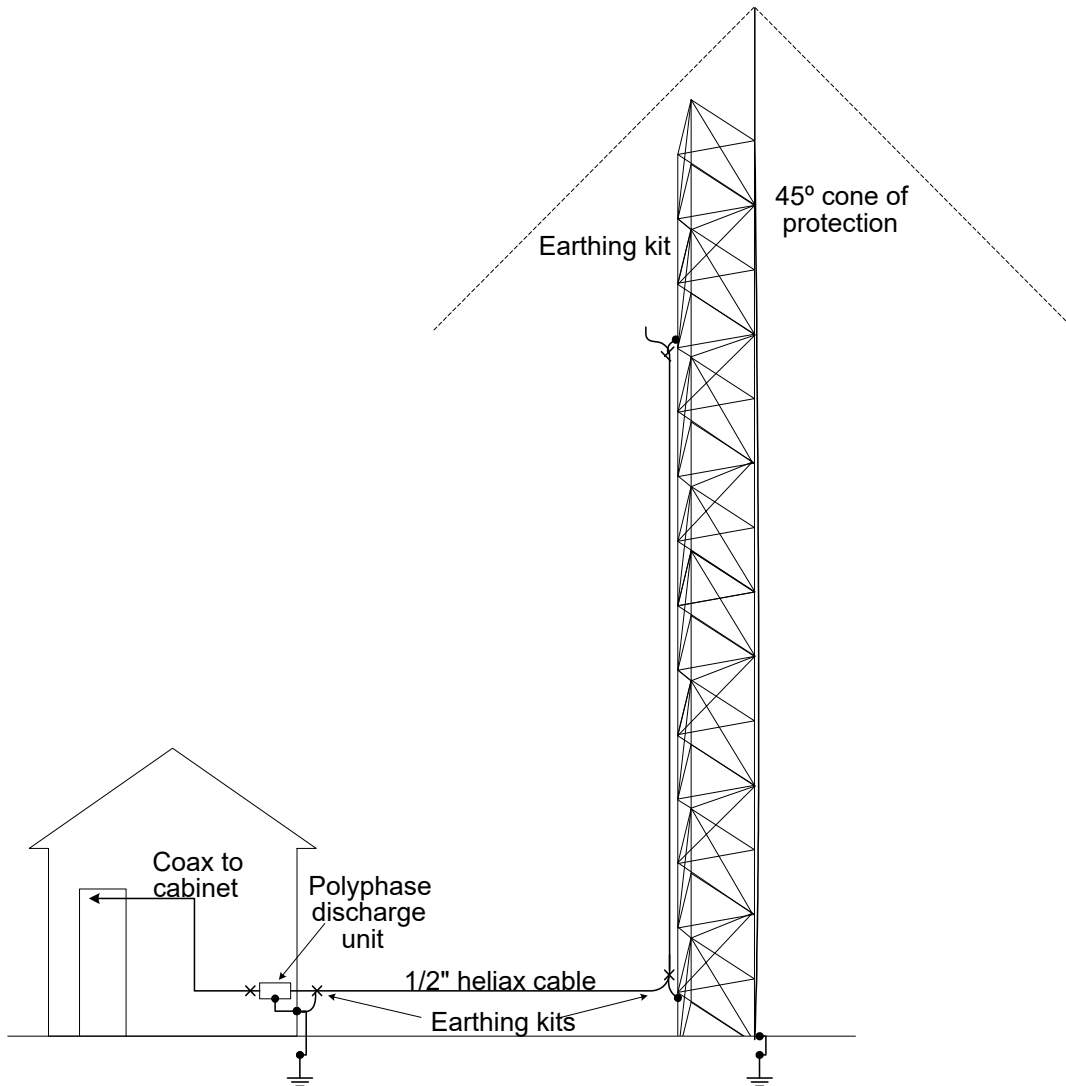

*Lightning protection*

A gas discharge unit is required to release high voltage charges developed between the cable inner and outer. There are two types available, a transmitting and a receiving variant. The transmitting variant is the larger. It is very important that these variants are not confused because the lower discharge potential rating for the receiver unit will be triggered by transmitting voltages. This will cause a high VSWR and poor performance.

**8.3 INSTALLATION**

Three styles of system installation are shown below. Of these, (a) has the lowest RF losses and the highest efficiency of power supply to the RU. However, mounting of the battery equipment up the pole may be considered a disadvantage from a mechanical or installation viewpoint. In (b), the RF losses are still low, but the DC power losses are highest, whilst in (c) the DC losses are minimised, and access is convenient but at the expense of RF performance. Option (b) may also be achieved using Power over Ethernet (PoE) which is described further in section 8.2.3.9.

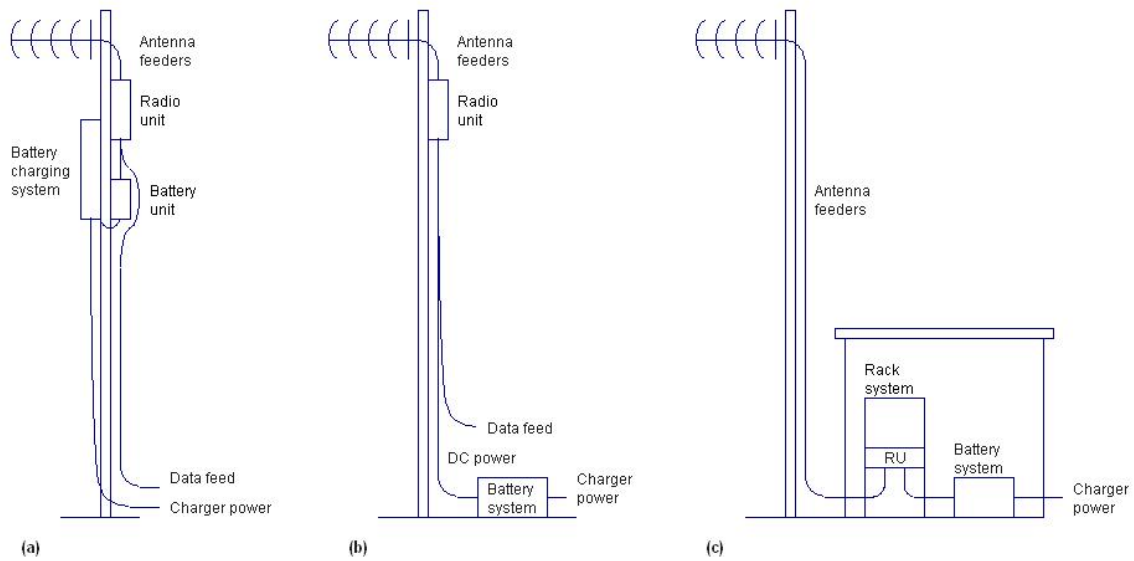

*Typical pole and rack mounting options for the radio unit*

Note: refer to section 8.2.6.1 for grounding and lightning protection considerations.

Regardless of the mounting configuration used, the appropriate site engineering must be undertaken. Site engineering must consider safety aspects such as grounding and lightning protection but also needs to take performance parameters such as antenna location, antenna separation and other RF sources. Please contact Mimomax if more information in these areas is required.

A comprehensive source of information and guidance on general site engineering issues has been published by ETSI: EG 200 053 v1.5.1, 2004/06 'Electromagnetic compatibility and Radio spectrum Matters (ERM); Radio site engineering for radio equipment and systems'. It is highly recommended that this freely available ETSI document be studied in detail, in conjunction with this manual.

## 8.4 COMPLIANCES

RF Bands	757-758 & 787-788 MHz
Radio Performance	FCC 47CFR part 27
EMC	FCC 47CFR part 15
Environmental	60950-22 Outdoor Safety
Safety	IEC 60950-1:2005, Am 1:2009, EN 62368-1:2014

*Table 7: Compliances*

## 9 DOCUMENT HISTORY

Issue #	Date	Description
1	13/April/2021	Update for Power Supply domain
	25/May/2021	Information for RF part updated
	10/June/2021	DC power updated