



TORNADO RADIO UNIT PRODUCT MANUAL

Issue 11 – [MONTH] 2021

This document contains proprietary information and must not be provided or copied to third parties without express permission from Mimomax Wireless Ltd

mimomax

Mimomax Wireless Ltd
Issue 11 – [MONTH] 2021
Product Manual for Tornado Radio Unit
Copyright © 2021 Mimomax Wireless Ltd.

Disclaimer

While precaution has been taken in the preparation of this literature and it is believed to be correct at the time of issue, Mimomax Wireless Ltd assumes no liability for errors or omissions or for any damages resulting from the use of this information. Due to a policy of continuous technical improvement, the contents of this document and any specifications contained therein are subject to revision and may change without notice.

WARRANTY

Mimomax Wireless Limited ("Mimomax") warrants for a period of 12 months from the date of delivery that its hardware items ("**Equipment**") will be free from defects due to defective design, workmanship or materials subject the conditions below ("**Warranty**").

CONDITIONS OF WARRANTY

This Warranty is strictly subject to the following conditions:

- (a) Mimomax will not be liable for breach of Warranty unless the customer (i) notifies Mimomax of the alleged defects within 30 days after the defect would have become reasonably apparent, and (ii) promptly returns the Equipment carriage paid with a full written report on the alleged defects.
- (b) The Warranty is not transferable.
- (c) Mimomax's liability under this Warranty is dependent on an assessment by Mimomax to determine and validate the defect in design, workmanship or materials.
- (d) The customer shall refund to Mimomax the cost to Mimomax of any replacement, repair or redelivery of any Equipment effected by Mimomax where the failure is not within the terms of this Warranty.
- (e) Mimomax does not guarantee that any service performed under this Warranty will be carried out within any particular timeframe.
- (f) To the fullest extent permitted by law, Mimomax's liability under this Warranty is limited to (at Mimomax's option) replacing or repairing the Equipment or the relevant part thereof without charge provided that its liability shall in no event exceed the purchase price of the Equipment or the relevant part thereof. Where Mimomax authorises the customer to undertake Warranty repairs, no reimbursement will be made in respect of labour.

GENERAL EXCLUSIONS

Mimomax shall not be liable under this Warranty:

- (a) where the Equipment has not been stored, installed, maintained and used properly having regard in particular to Mimomax's and (if any) other agreed applicable specifications and instructions including (without limitation) in relation to the installation of engineering changes or enhancements;
- (b) where the Equipment has not been used in accordance with interference-free power, suitable environment (including but not limited to free from electronic or radio interference and pests) and correct maintenance of the Equipment;
- (c) for third party interference, fair wear and tear, abuse, damage or misuse, correction or repairs or modifications made other than by Mimomax or any repairs required due to events beyond the control of Mimomax;
- (d) for abnormal conditions (electrical, thermal, chemical or otherwise), including (without limitation) factors outside the operational parameters for the Equipment;
- (e) for any defect caused by or arising from use of any software not licensed or supplied by Mimomax, or otherwise caused by or arising from the customer's acts or omissions.

LIMITATION OF LIABILITY

Except as set out in this Warranty and to the maximum extent permitted by law:

- (a) all warranties, conditions, liabilities and obligations with respect to any Mimomax product, software or services (including as to merchantability, description quality, or fitness for a specific purpose) are expressly excluded; and
- (b) Mimomax shall not be liable for any losses or damages (whether direct or indirect) including property damage or personal injury, consequential loss, economic loss or loss of profits or other economic advantage, however caused which may be suffered or incurred by the customer or any third person, or which may arise directly or indirectly out of or in respect of any Mimomax product, software or services or by reason of any act or omission on the part of Mimomax.

CUSTOMER ACKNOWLEDGEMENT

The customer acknowledges that:

- (a) if the Consumer Guarantees Act 1993 ("**CGA**") applies, this Warranty shall be read subject to customer's rights under the CGA. Where the customer uses the Equipment for business purposes, the provisions of CGA, or any other relevant consumer protection legislation, shall not apply;
- (b) the Equipment is not designed or intended for use in on-line control of aircraft, air traffic, aircraft navigation or aircraft communications; intrinsically safe environments or in the design, construction, operation or maintenance of any nuclear facility. Mimomax disclaims any express or implied warranty of fitness for such uses. The customer will not use or resell Equipment for such purposes;
- (c) any software supplied by Mimomax cannot be tested in every possible permutation and accordingly Mimomax does not warrant that software supplied will be free of all defects or that its use will be uninterrupted.

Table of Contents

- Abbreviations And Acronyms 6
- 1 Tornado System Overview 9
 - 1.1 Network Digital Links (NDL) 9
 - 1.2 Multipoint Digital Links (MDL)..... 10
 - 1.3 Optimised Protection Variant (OPV)..... 11
- 2 Safety Warnings..... 13
 - 2.1 Modifications 13
 - 2.2 Transmitter Antenna..... 13
 - 2.3 Safety Distance 13
 - 2.4 FCC RF Exposure Statement..... 14
 - 2.5 Electrical Safety Cable Screening 14
 - 2.6 Mains Connection..... 15
 - 2.7 FCC 15.19 statement 15
 - 2.8 FCC 15.105(b) statement..... 15
- 3 Tornado radio unit overview 16
 - 3.1 Connectors..... 16
 - 3.2 Digital Processing System..... 17
 - 3.2.1 Power Supply 17
 - 3.2.2 Central Processor Unit 17
 - 3.2.3 FPGA 17
 - 3.2.4 Receive Converters..... 17
 - 3.2.5 Transmit Converters..... 17
 - 3.2.6 Reference & Clock Synthesisers 17
 - 3.2.7 Dual Ethernet 17
 - 3.2.8 Dual Serial..... 18
 - 3.2.9 GPIO 18
 - 3.2.10 Alarm..... 18
 - 3.2.11 Front Panel Leds..... 18
 - 3.3 Receiver RF/IF Sections 18
 - 3.3.1 Front End 18
 - 3.3.2 Mixer And Lo Buffer 18
 - 3.3.3 If And Agc Circuitry 18
 - 3.3.4 Local Oscillator..... 18
 - 3.4 Transmitter RF/IF Sections 19
 - 3.4.1 Forward Signal Path..... 19
 - 3.4.2 Feedback Signal Path 19
 - 3.4.3 Local Oscillator..... 19
 - 3.4.4 Internal Duplexer..... 19

- 4 Setting Up on the Bench 20
 - 4.1 Testing The Network Setup 21
- 5 Configuration Control and Monitoring System (CCMS) 23
- 6 Changing Operating Frequency and Power Calibration 24
 - 6.1 Introduction 24
 - 6.2 Equipment Required: Power Meter 24
 - 6.3 Process Overview 24
 - 6.4 Ccms Process 24
 - 6.5 Power Calibration 25
 - 6.5.1 Calibrating Tx (Coarse Step) 26
 - 6.5.2 Calibrating Tx (Fine Step) 26
 - 6.5.3 Complete Calibration Of One Tx 27
 - 6.5.4 Complete Both Transmitter Calibration 27
 - 6.5.5 Calibration Fault 28
- 7 Duplexer Tuning Guide 29
 - 7.1 Duplexer Tuning 29
 - 7.2 400-470mhz Duplexer Tuning Guide 29
 - 7.3 400mhz Internal Duplexers 29
 - 7.3.1 Tools/Equipment Required 30
 - 7.3.2 Procedure 31
 - 7.4 Rssi Calibration 32
 - 7.5 Reference Calibration 34
 - 7.5.1 Equipment Required For Reference Calibration 34
 - 7.5.2 How To Calibrate The Reference 34
- 8 Radio Reference Information 35
 - 8.1 Mechanical Dimensions And Mounting 35
 - 8.1.1 Dimensions 35
 - 8.1.2 Mounting 35
 - 8.2 Input And Output 39
 - 8.2.1 Connectors 40
 - 8.2.2 Led Behaviour 40
 - 8.2.3 Essential Power Requirements 41
 - 8.2.4 Electrical Characteristics 44
 - 8.2.5 Interface Ports 46
 - 8.2.6 RF Specification 48
 - 8.3 Installation 52
 - 8.4 Compliances 54
- 9 DOCUMENT HISTORY 55

ABBREVIATIONS AND ACRONYMS

AC	Alternating Current
ACMA	Australian Communications and Media Authority
ADC	Analogue to Digital Converter
ADPCM	Adaptive Differential Pulse Code Modulation
AFC	Automatic Frequency Control
AGC	Automatic Gain Control
ANT	Antenna
BER	Bit Error Rate
BRU	Base Radio Unit
BW	Bandwidth
CAT	Category
CCMS	Configuration Control & Monitoring Software
CODECS	Coder Decoder
CPU	Central Processing Unit
CRC	Cyclic Redundancy Check
CSV	Comma Separated Value
DAC	Digital to Analogue Converter
DC	Direct Current
DFE	Decision-Feedback Equalizer
DIF	Digital Interface
DPLXR	Duplexer
DPS	Digital Processing System
DRU	Diversity Radio Unit
DSP	Digital Signal Processing
DTE	Data Terminal Equipment
EF	Express Forward
EMC	Electromagnetic Compatibility
ERM	Electromagnetic Compatibility and Radio Spectrum Matters
ESD	Electrostatic Sensitive Device
ETSI	European Telecommunications Standards Institute
FCC	Federal Communications Commission
FIFO	First In, First Out
FPGA	Field-Programmable Gate Array
FTP	File Transfer Protocol
GND	Ground
GPS	Global Positioning System
GRE	Generic Routing Encapsulation
HPF	High Pass Filter
HSSI	High Speed Serial Interface

HTML	Hyper-Text Mark-Up Language
IF	Intermediate Frequency
IO	Input Output
IP	Internet Protocol
ITU	International Telecommunication Union
LED	Light Emitting Diode
LNA	Low Noise Amplifier
LO	Local Oscillator
LPF	Low Pass Filter
LRU	Link Radio Unit
MAC	Media Access Control
MCAM	Mimomax Cognisant Adaptive Modulation
MDAP	Mimomax Data Acceleration Protocols
MDIX	Medium Dependent Interface Crossover
MDL	Multipoint Digital Link
MIB	Management Information Base
MIMO	Multi Input Multi Output
MRAP	Mimomax Routing Adaptation Protocols
NDL	Network Digital Link
NIB	Network Interface Board
NTP	Network Time Protocol
OPV	Optimised Protection Variant
OSI	Open System Interconnection
OSPF	Open Shortest Path First
OTAC	Over the Air Configuration
OTAP	Over the Air Programming
PA	Power Amplifier
PC	Personal Computer
PCB	Printed Circuit Board
PECL	Positive Emitter-Coupled Logic
PIF	Power Interface
PIN	P-Type, Intrinsic, N-Type
PLL	Phase Locked Loop
PMR	Private Mobile Radio
PSU	Power Supply Unit
QAM	Quadrature Amplitude Modulation
QPSK	Quadrature Phase-Shift Keying
RF	Radio Frequency
RFI	Radio Frequency Interference
RRU	Remote Radio Unit
RSSI	Received Signal Strength Indication
RTP	Real-Time Protocol

RU	Radio Unit
RX	Receive
SCADA	Supervisory Control and Data Acquisition
SEPIC	Single Ended Primary Inductor Converter
SFE	Software Feature Enabler
SMB	Sub miniature Version B
SNMP	Simple Network Management Protocol
SPI	Serial Peripheral Interface
SS	Synchronous Serial
TCP	Transmission Control Protocol
TTR	Time to Repair
TX	Transmit
UART	Universal Asynchronous Receiver/Transmitter
UDP	User Datagram Protocol
UHF	Ultra-High Frequency
USD	United States Dollar
VCO	Voltage Controlled Oscillator
VCTCXO	Voltage-Controlled Temperature-Compensated Crystal Oscillator
VRMS	Volts Root Mean Square
VRRP	Virtual Router Redundancy Protocol
VSWR	Voltage Standing Wave Ratio

1 TORNADO SYSTEM OVERVIEW

Mimomax Tornado delivers the next generation of high performance true MiMO narrowband remote radios for SCADA, Protection and Linking applications. The Tornado is the market leader for narrowband throughput and functionality with a full duplex aggregate one-way raw data rate of up to 960kb/s in 75kHz in its highest modulation mode.

Tornado radios provide a radio wireless infrastructure for connecting devices used by various applications to form a network through which IP data, RS-232 serial data or RS485 synchronous serial data can seamlessly flow. Features include isolated power supply with low power consumption, full duplex operation with built in duplexers and supporting a combination of interfaces, with very high scalable data rates, remote over the air network management, optional SNMP, ModBus and DNP3 support and a very efficient random-access protocol.

Operating in the licensed frequency bands between 400-470MHz & 806-960MHz, 700Mhz Upper A-Block and VHF, with a wide temperature operating range and optional waterproof outdoor mount. The Tornado enables unrivalled performance while maintaining Mimomax's renowned reputation for reliability and operational efficiency.

The Mimomax Tornado radio platform is configurable in three types of system linking, Network Digital Links (NDL), Multi-Point Digital Links (MDL) and an Optimised Protection Variant (OPV) of the NDL link. The one Tornado radio platform can be configured differently for the different roles required by these links through the enabling and disabling of features and functionalities.

1.1 NETWORK DIGITAL LINKS (NDL)

The Mimomax NDL is a highly reliable and robust point-to-point wireless linking solution designed to support PMR Linking, SCADA and Backhaul applications.

An NDL link is a simple point-to-point over-the-air connection between two Tornado radios in NDL mode. One is configured as master, the other as slave. This link allows for very quick data transfer. Modulation can be fixed or adaptive.



Simple NDL Link Diagram

Utilizing the MiMO technology and full-duplex operation, this narrowband fixed wireless solution provides a reliable low-error data transport service. A number of internal interfaces are available to support various SCADA applications and also multichannel, conventional, analogue, simulcast, MPT, P25 and/or TETRA digital networks in trunked and simulcast configurations.

For PMR applications, a separate high-quality Network Interface Box (NIB) with up to 6 x 32k ADPCM audio channels plus 9k6 RS232 signalling channel, supports analogue networks.

Multiple links can be cascaded to cope with difficult terrain and very long paths. Different mounting options provide the much-needed flexibility for varied network requirements. Being fully compatible with the rest of the Mimomax product types, NDL can be incorporated into the Mimomax MDL (point-to-multipoint) linking solution.

NDL links are well-suited for providing backhaul links between sites in P25, DMR and MPT networks. Each link can carry multiple voice channels (the number varies with the modulation scheme) and have residual bandwidth for maintenance tasks. A high priority queue is available to provide EF priority to voice and other critical data over the link. The following diagram shows a simplified two-site trunked P25 network with an NDL link providing the backhaul between the remote site and the central site.

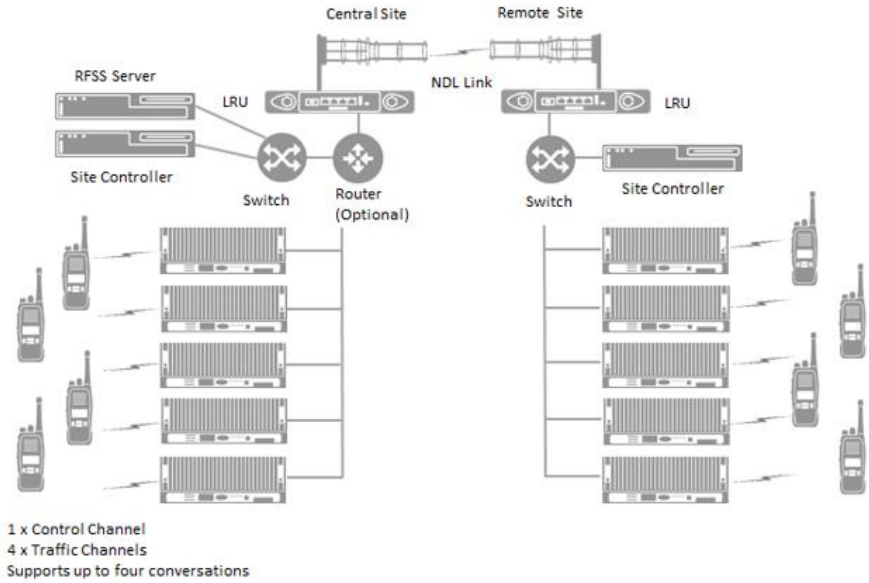

Simplified Two-Site Trunked P25 Network

1.2 MULTIPOINT DIGITAL LINKS (MDL)

The Mimomax MDL is a highly reliable and robust point-to-multipoint wireless linking solution designed for mission-critical Supervisory Control and Data Acquisition (SCADA) and Telemetry applications. It consists of one or more Base Radio Units (BRUs) where each BRU supports up to 354 active Remote Radio Units (RRUs) with largest settable RRU ID of 356. An exception to it is 4.6.x series which were limited to support up to 135 RRUs while still maintaining IDs settable between 3 and 356.

The Mimomax MDL supports both native IP and legacy Asynchronous Serial RS232 Remote Terminal Units (RTUs) by means of optional embedded Terminal Server software. A number of interfaces are available to support various applications. Additionally, the system is capable of supporting remote outstations simultaneously on different modulation schemes to accommodate various data rates and link paths.

Very high system gains and good receiver sensitivities mean that it is possible to achieve paths in excess of 100kms from high radio sites at full speed. Furthermore, any branch of MDL can be extended by using the Mimomax point-to-point Network Digital Link (NDL) radio communications solution.

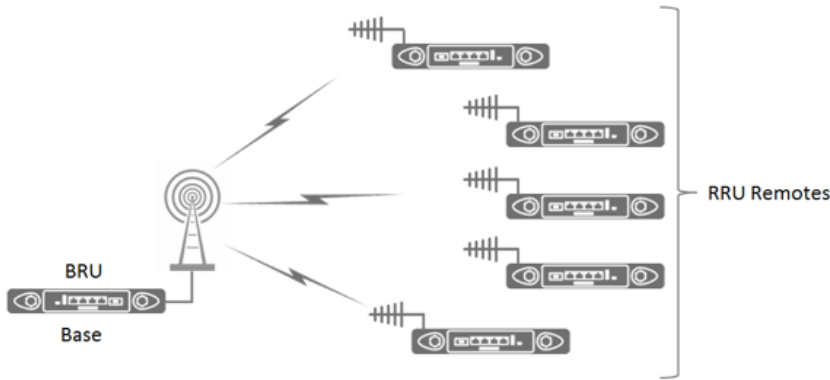

Basic Point-to-Multi-Point Linking Diagram

SCADA networks can use MDL links to connect remote RTUs to the central SCADA master. These links can be cascaded with an NDL link to cope with difficult terrain or very long paths.

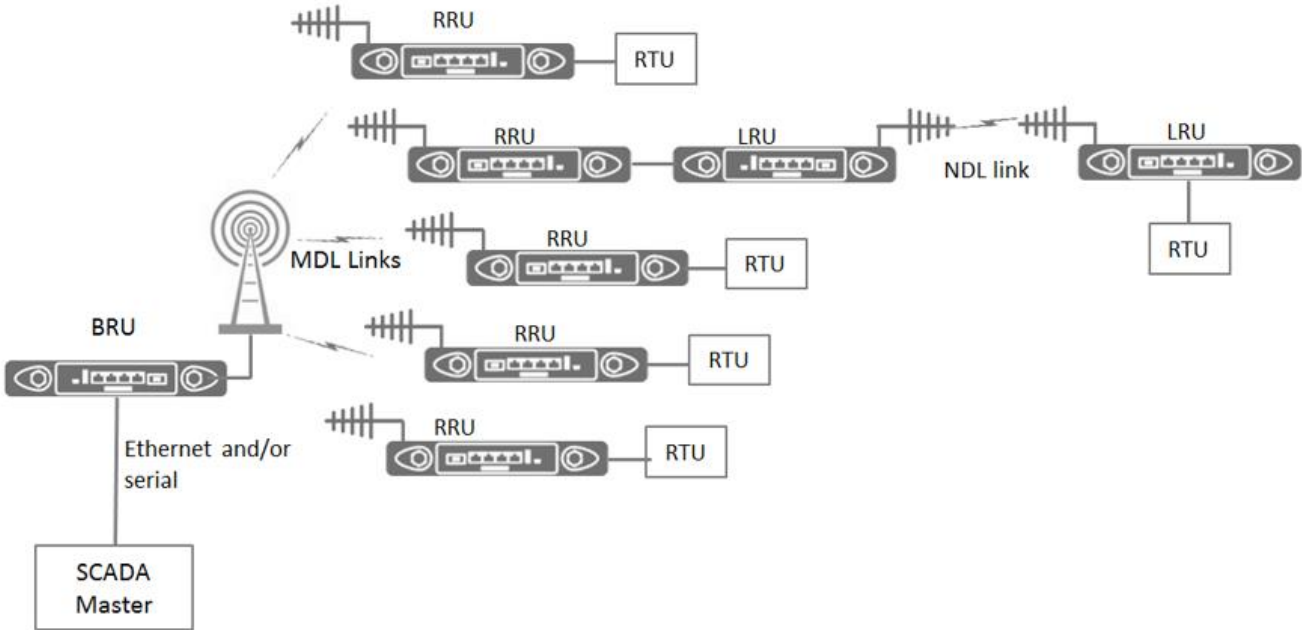

SCADA Network Example

1.3 OPTIMISED PROTECTION VARIANT (OPV)

The Mimomax OPV is a highly intelligent point-to-point radio system that provides complete rural substation Tele protection communications solution for both power line protection and SCADA applications. It is designed to meet CAT I, II and III protection levels. Hence, can be employed to link power line protection relays (e.g. General Electric L90) within critical network infrastructure.

In addition to providing a low latency, low jitter 64kbps protection channel, it also provides at least 64kbps Ethernet capacity over the same radio link. The protection relays typically use the radio link to exchange data packets at 64kbps, containing power system voltage and current magnitude and phase angle information. This information is used to determine whether there is an unexpected event or power loss on the line and to transmit information used to trip circuit breakers when a line fault is detected.

The interface required for the protection relays is typically synchronous serial using V11 (RS422), X-21 or G703 signaling at 64kbps transmission rate. However, a number of other synchronous serial interfaces can also be accommodated. Furthermore, multiple layers of security ensure that the mission-critical operations remain highly secure.

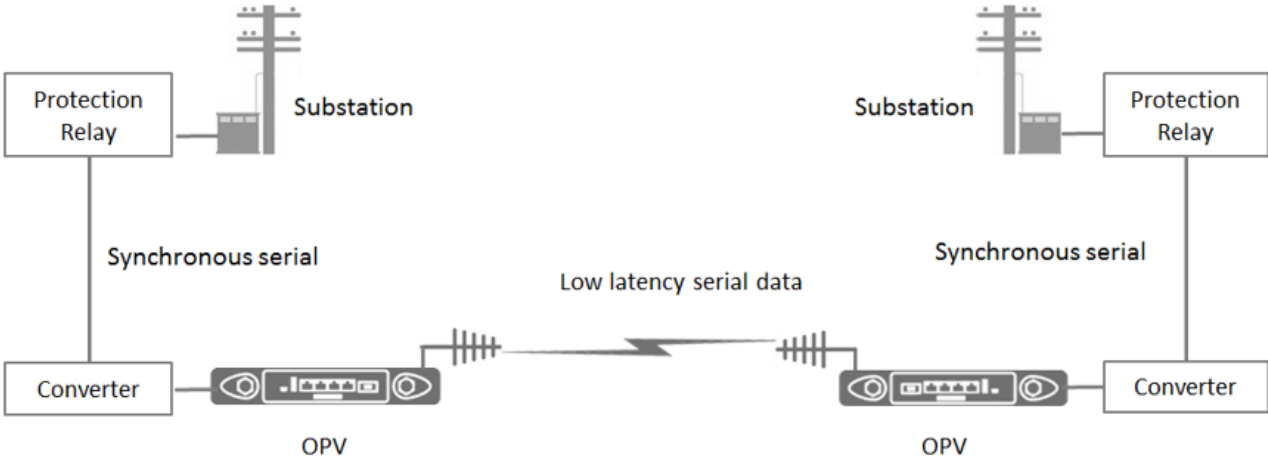

OPV Example Network Diagram

Mimomax Tornado OPV-T Synchronous Serial Latency Table

Bandwidth	Modulation	X21 64kbps	X21 128kbps	X21 192kbps	X21 256kbps	RS422 64kbps	RS422 128kbps	RS422 192kbps	RS422 256kbps	C37.94	G703
50kHz	QPSK	4.6	4.5	-	-	4.4	4.5	-	-	5.3	5.2
	16QAM	2.9	2.8	2.8	2.7	3.0	2.8	2.6	2.7	3.7	3.5
	64QAM	2.4	2.2	2.2	2.2	2.3	2.2	2.2	2.2	3.1	2.9
	256QAM	2.1	1.9	1.9	1.9	2.2	1.9	1.9	1.8	2.7	2.6
25kHz	QPSK	9.0	-	-	-	9.0	-	-	-	9.5	9.5
	16QAM	5.5	5.0	-	-	5.5	5.0	-	-	5.9	5.9
	64QAM	4.5	4.4	4.2	-	4.5	4.4	4.2	-	4.8	4.8
	256QAM	4.0	3.8	3.6	3.6	4.0	3.8	3.6	3.6	4.3	4.3
12.5kHz	QPSK	-	-	-	-	-	-	-	-	-	-
	16QAM	10.7	-	-	-	10.7	-	-	-	11.0	11.0
	64QAM	8.0	-	-	-	8.0	-	-	-	9.0	9.0
	256QAM	7.5	7.2	-	-	7.5	7.2	-	-	8.0	8.0

Note 1: Latencies figures are in milliseconds
 Note 2: Latencies figures are for a single radio hop and are one way (not round trip)

2 SAFETY WARNINGS

2.1 MODIFICATIONS

NOTE: THE GRANTEE IS NOT RESPONSIBLE FOR ANY CHANGES OR MODIFICATIONS NOT EXPRESSLY APPROVED BY THE PARTY RESPONSIBLE FOR COMPLIANCE. SUCH MODIFICATIONS COULD VOID THE USER'S AUTHORITY TO OPERATE THE EQUIPMENT.

2.2 TRANSMITTER ANTENNA

Under Industry Canada regulations, this radio transmitter may only operate using an antenna of a type and maximum (or lesser) gain approved for the transmitter by Industry Canada.

To reduce potential radio interference to other users, the antenna type and its gain should be so chosen that the equivalent isotropically radiated power (E.I.R.P.) is not more than that necessary for successful communication.

Conformément à la réglementation d'Industrie Canada, le présent émetteur radio peut fonctionner avec une antenne d'un type et d'un gain maximal (ou inférieur) approuvé pour l'émetteur par Industrie Canada.

Dans le but de réduire les risques de brouillage radioélectrique à l'intention des autres utilisateurs, il faut choisir le type d'antenne et son gain de sorte que la puissance isotrope rayonnée équivalente (P.I.R.E.) ne dépasse pas l'intensité nécessaire à l'établissement d'une communication satisfaisante.

2.2.1 TORNADO 700MHZ TRANSMITTER ANTENNA

According to FCC compliance requirement on maximum E.R.P limitation specified in part 27, an antenna with maximum gain of 38.06dBi or 22.83dBi is allowed to use for 757-758MHz band and 787-788MHz band respectively. The use of other antennas with higher gain should be combined with tuning down the Tornado transmitter output power to appropriate level to assure the system E.R.P (or E.I.R.P) meets the FCC requirement.

Selon l'exigence de conformité de la FCC sur la limite maximale de P.R.E spécifiée dans la partie 27, une antenne ayant un gain maximal de 38,06dBi ou 22,83dBi est autorisée pour la bande 757-758MHz et la bande 787-788MHz respectivement. L'utilisation d'autres antennes ayant un gain plus élevé devrait être combinée avec le réglage de la puissance de sortie de l'émetteur Tornado X au niveau approprié pour s'assurer que le système E.R.P. (ou E.I.R.P) répond aux exigences de la FCC.

Below antennas from Mimomax Wireless are recommended to use with Tornado

Dual Polarized Omni-Directional Antenna	8dBi, 2xN Female
Dual Polarized Compact Panel Antenna	8dBi, 2xN Female
Dual Polarized, MIMO Directional Panel Antenna	9dBi, 2xN Female
Compact Panel Antenna	9dBi, 2xN Female / 2x4.3-10 Female
Compact Panel Antenna	11dBi, 2xN Female / 2x4.3-10 Female
MIMO Low Profile Panel Antenna	12dBi, 2xN Female
MIMO Panel Antenna	16dBi, 2xN Female / 2x4.3-10 Female
MIMO Yagi Antenna (with optional Radome available)	12dBi, 2xN Female
MIMO Yagi Antenna (with optional Radome available)	15dBi, 2xN Female

2.3 SAFETY DISTANCE

Minimum Safe Distance from Antenna: To comply with safety requirements for human RF exposure in the USA, Canada and other countries, no person shall be permitted to remain in the vicinity of the antenna of an operational Mimomax Tornado system at distances closer than the following:

2.3.1 TORNADO 700MHZ SAFETY DISTANCE

General Public/Uncontrolled Use: 0.26m when using a 16dbi Panel Antenna with a Mimomax Tornado radio.

The above distances are based on procedures defined by regulatory standards for equipment operating at maximum power and 100% duty cycle with a person located directly in front of the antenna in the main radiation lobe.

2.4 FCC RF EXPOSURE STATEMENT

The transmitter must not be co-located or operated in conjunction with any other antenna or transmitter. The equipment complies with FCC RF radiation exposure limits set forth for an uncontrolled environment.

2.4.1 TORNADO 700MHZ FCC RF EXPOSURE STATEMENT

This equipment should be installed and operated with a minimum distance of 39cm between the radiator and any part of your body.

2.5 ELECTRICAL SAFETY CABLE SCREENING

Equipment connected to the protective earthing of the building installation through the mains connection or through other equipment with a connection to protective earthing - and to a cable distribution system using coaxial cable, may in some circumstances create a fire hazard. Connection to a cable distribution system has therefore to be provided through a device providing electrical isolation below a certain frequency range (galvanic isolator, see EN 60728-11).

NOTE: In Norway, due to regulation for installations of cable distribution systems, and in Sweden, a galvanic isolator shall provide electrical insulation below 5 MHz. The insulation shall withstand a dielectric strength of 1,5 kV r.m.s., 50 Hz or 60 Hz, for 1 min.

Utstyr som er koplet til beskyttelsesjord via nettplugg og/eller via annet jordtilkøpelt utstyr - og er tilkøpelt et kabel-TV nett, kan forårsake brannfare. For å unngå dette skal det ved tilkøpling av utstyret til kabel-TV nettet installeres en galvanisk isolator mellom utstyret og kabel-TV nettet.

Utrustning som är kopplad till skyddsjord via jordat vägguttag och/eller via annan utrustning och samtidigt är kopplad till kabel-TV nät kan i vissa fall medföra risk för brand. För att undvika detta skall vid anslutning av utrustningen till kabel-TV nät galvanisk isolator finnas mellan utrustningen och kabel-TV nätet.

2.6 MAINS CONNECTION

The Mains connection of the supply providing the DC supply to the Mimomax Tornado unit shall be either:

- PERMANENTLY CONNECTED EQUIPMENT.
- PLUGGABLE EQUIPMENT TYPE B.
- Or equipment intended to be used in a RESTRICTED ACCESS LOCATION where equipotential bonding has been applied and which has provision for a permanently connected PROTECTIVE EARTHING CONDUCTOR and is provided with instructions for the installation of that conductor by a SERVICE PERSON.

2.7 FCC 15.19 STATEMENT

THIS DEVICE COMPLIES WITH PART 15 OF THE FCC RULES. OPERATION IS SUBJECT TO THE FOLLOWING TWO CONDITIONS: (1) THIS DEVICE MAY NOT CAUSE HARMFUL INTERFERENCE, AND (2) THIS DEVICE MUST ACCEPT ANY INTERFERENCE RECEIVED, INCLUDING INTERFERENCE THAT MAY CAUSE UNDESIRE OPERATION.

2.8 FCC 15.105(B) STATEMENT

Note: This equipment has been tested and found to comply with the limits for a Class B digital device, pursuant to part 15 of the FCC Rules. These limits are designed to provide reasonable protection against harmful interference in a residential installation. This equipment generates, uses and can radiate radio frequency energy and, if not installed and used in accordance with the instructions, may cause harmful interference to radio communications. However, there is no guarantee that interference will not occur in a particular installation. If this equipment does cause harmful interference to radio or television reception, which can be determined by turning the equipment off and on, the user is encouraged to try to correct the interference by one or more of the following measures:

- Reorient or relocate the receiving antenna.
- Increase the separation between the equipment and receiver.
- Connect the equipment into an outlet on a circuit different from that to which the receiver is connected.
- Consult the dealer or an experienced radio/TV technician for help.

3 TORNADO RADIO UNIT OVERVIEW

3.1 CONNECTORS

The image below shows each of the different connectors. The Ethernet connectors are 10/100 Base-Tx connected to a two-port switch (either port can be used). The operating input voltage range of the power supply is 10.5 to 64 VDC. The power supply must be able to supply at least 30 watts.

Warning: Do not power up the radio unit without a load (attenuator or antenna) connected to each of the N connectors. Damage to the radio may occur otherwise.

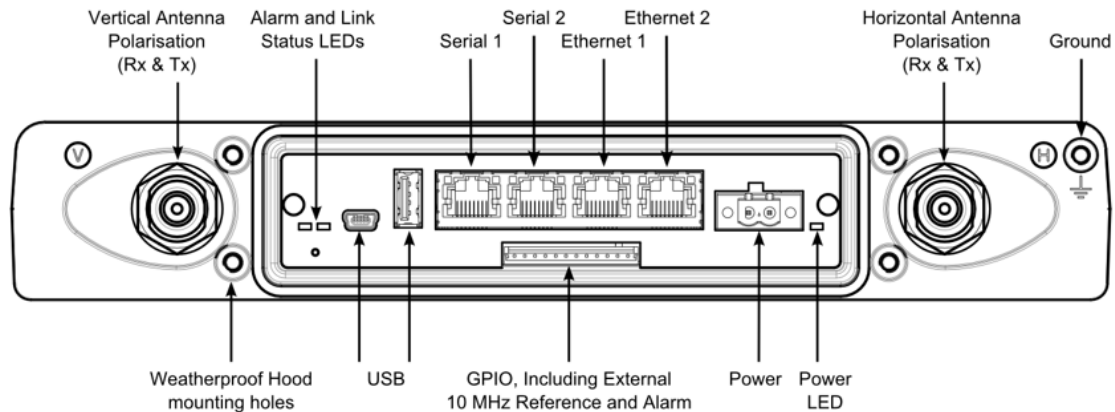

Connectors

Each radio unit can operate as either a Base Radio Unit (BRU) or Remote Radio Unit (RRU) as part of a Multi-point Digital Link (MDL) system or alternatively as a NDLE unit as part of a Network Digital Link (NDL) system. The actual mode of operation will depend on the Software Feature Enablers (SFEs) purchased and the product type configured.

A MDL system consists of one BRU, tuned to one Tx/Rx frequency pair, with a number of RRU's, all tuned to the corresponding, but opposite, Tx/Rx frequency pair. An NDL system consists of one 'master' NDL unit tuned to one frequency pair with its corresponding 'slave' unit tuned to the opposite pair.

Mimomax Tornado radios consist of the following modules.

- Digital Processing System (DPS)
- Transceiver (TRCVR)
- Duplexers (DPLXR)

These modules are described in detail in the sections that follow.

User data (Ethernet or serial) passes from the various interfaces into the Digital Processing System (DPS) where sophisticated processing takes place to code the data into a MIMO signal. This MIMO signal is created completely digitally inside the DPS. The DPS then generates two signals at an IF frequency. There are two signals because ultimately the signals will pass onto separate elements on the antenna. The Intermediate Frequency (IF) signals are then passed on to the Transmitter module which mixes the signals up to the desired frequency and also amplifies the signals to the required levels. The signals then pass through the duplexers. The duplexers are special filters which prevent the transmitted signals from feeding back into the receiver module. Next the signals are fed to the antenna.

The antenna is a special MIMO antenna which is able to transmit and receive on both the vertical and horizontal polarisations at the same time. The MIMO antennas are essentially two antennas in one.

On the receive path, the radio signals are picked up by the MIMO antenna and fed through the duplexers and into the receiver module. The receiver selects the radio frequency to receive and mixes this signal down to an IF. This IF signal is then sampled by Analogue to Digital Converters (ADCs) on the DPS module. The DPS module then performs very complex MIMO processing to decode the user data that was sent. This data is then passed to the appropriate interface.

3.2 DIGITAL PROCESSING SYSTEM

The DPS is the heart of the radio unit. It provides an accurate and stable 40MHz system reference clock from which all the required digital clocks and RF local oscillator frequencies for transmit and receive functions are derived. It processes signals that have been transmitted or received and provides overall control and monitoring to the rest of the system via the built-in Configuration, Control and Management Software CCMS software. Power supplies are also provided by the DPS.

3.2.1 POWER SUPPLY

The power supply operates off a 10.5 to 60 VDC input and generates stable 13.5V, 5.4V, 5.0V, 3.3V, 2.5V, 1.8V, 1.2V and 18V internal power supply rails, that all the other circuitry runs off. The input of the power supply is isolated from the rest of the circuitry and the chassis. Input voltage monitoring is provided via CCMS.

3.2.2 CENTRAL PROCESSOR UNIT

An ARM Cortex A8 based microcontroller is used as the CPU in the DPS board. It uses a reference clock of 26MHz. The CPU provides external device connectivity through the built-in and external peripherals.

The CPU runs a Linux embedded operating system which provides various services such as scheduling, process management, memory management, device and resource management, TCP/IP stacks and inter-networking, applications, user interface, system configuration and control etc. An integral part of the Linux operating system is the Mimomax specific network driver, which configures the radio unit as a standard Ethernet device.

3.2.3 FPGA

An Altera Cyclone IV Field Programmable Gate Array is used to implement the physical layer TX and Rx signal processing, MAC layer and signalling protocols on the serial interfaces.

3.2.4 RECEIVE CONVERTERS

The 45.1MHz analogue IF signals from each receiver channel are fed to a dual 10-bit ADC. The signals are sampled using a 40MHz clock which is generated from the 40MHz system reference clock. The digital outputs from the ADC are fed to the FPGA for processing.

3.2.5 TRANSMIT CONVERTERS

The digital transmit signals from the FPGA are fed to a dual 14-bit DAC which uses a clock frequency of 40MHz to produce the analogue IF signal for each transmitter channel. The IF output is 15.3835MHz. This is chosen in conjunction with the transmitter local oscillator frequency to minimise the generation of spurious frequencies in the transmitted RF output spectrum.

3.2.6 REFERENCE & CLOCK SYNTHESISERS

The main system reference clock consists of a low-noise, voltage-controlled, temperature-compensated, crystal oscillator (VCTCXO) operating at 40MHz. Factory calibration of this oscillator against an external GPS or other frequency reference is provided by means of a non-volatile sample-and-hold facility which adjusts the VCTCXO DC control voltage to set the frequency precisely to 40.0MHz. The VCTCXO may also be phase-locked to an external 10 MHz reference if required. If the external reference input is not in use the internal reference divided down to 10 MHz can be provided as an output. External reference in/out is provided via an isolated differential connection on the GPIO connector.

The 40MHz output from the VCTCXO is buffered and distributed to provide low-noise differential reference signals for the transmitter and receiver local oscillators, transmit DACs, receive ADCs and the FPGA.

The 40MHz output from the VCTCXO also feeds a PLL IC which generates a 26MHz clock for the CPU and a 25MHz clock for the Ethernet controller IC.

3.2.7 DUAL ETHERNET

The Ethernet is provided via a three-port managed Ethernet switch, one port is the internal connection to the CPU, and the other two ports are available on the RJ45 connectors labelled 'Eth1' and 'Eth2' on the front panel. The Ethernet ports are both 10/100BASE-Tx ports, supporting full and half duplex, flow control, auto MDI-X and auto negotiation.

3.2.8 DUAL SERIAL

The two serial ports, 'Serial 1' and 'Serial 2' on the front panel, operate as RS232 ports can either operate via a terminal server application (NDL and MDL) or providing a transparent end to end RS232 connection (NDL only). In a NDL system the serial ports are also able to provide X-21, RS422, G703, C37.94 or Mimomax HSSI2 via external interface converters.

3.2.9 GPIO

Four GPIO ports are provided, these are able to be open collector digital outputs capable of withstanding 70 VDC, and sinking up to 100mA. Or they can be used as either digital or analogue input ports, making use of a 12-bit Analogue to Digital converter. The direction and mode of each can be set independently.

3.2.10 ALARM

A single set of voltage free change over contacts are provided as an alarm indication, these are current limited to 750mA. The alarm port is also on the GPIO connector.

3.2.11 FRONT PANEL LEDS

LEDs on the front panel indicate Power, RF link status and Alarm. A green LED by the power connector is on when the internal 3.3 Volt power supply is on. A green LED labelled 'Link' is on when a RF link is active. A red LED labelled 'Alarm' flashes during boot up. It will also flash when the alarm is active.

3.3 RECEIVER RF/IF SECTIONS

The receiver has two identical channels, each with separate RF, mixer and IF stages. A common local oscillator feeds both channels simultaneously. RF input to each channel is by means of a PCB-mounted 50Ω SMB connector. With the exception of the VCO/synthesiser sections the descriptions below apply equally to either receive channel.

3.3.1 FRONT END

The Front End resides on the duplexer board. Incoming signals are fed through a band pass duplexer which provides effective rejection of out-of-band frequencies beyond the centre frequency (approximately +/-3MHz). Following the filter, is the receiver Low Noise Amplifier (LNA). This is followed by a fixed image reject filter to remove noise attributed to the LNA as the majority of image rejection comes from the internal duplexers.

3.3.2 MIXER AND LO BUFFER

The RF signal from the front end is converted down to an Intermediate Frequency (IF) by means of a mixer and LO Buffer.

3.3.3 IF AND AGC CIRCUITRY

The signal from the mixer feeds a 45.1MHz 4-pole crystal filter. It then passes via a buffer amplifier to a second IF filter which is a 2-pole crystal unit. This gives a total of 6 poles of analogue IF filtering. Primary rejection of adjacent channels is provided by post-IF DSP filtering further down the receive chain.

Following the second IF filter are two-stage variable-gain AGC amplifiers which provide >100dB effective gain adjustment, using a DC control voltage derived from a 10-bit DAC. The balanced output from the second stage amplifier is fed via an anti-aliasing band pass filter to an analogue-to-digital converter (ADC) and subsequent digital processing circuitry.

At maximum gain the 45.1MHz IF amplifier chain provides >90dB gain from 1st IF filter input to the balanced IF output (total receiver gain from RF input to IF output: >100dB). In operation, the post-IF receiver processing circuitry adjusts the AGC control voltage via the DAC to maintain the signal level into the receiver ADC within its linear operating region.

3.3.4 LOCAL OSCILLATOR

The receiver local oscillator consists of a programmable fractional-N phase-locked loop (PLL) frequency synthesiser, using a stable reference frequency from an internal 40MHz temperature-compensated crystal

oscillator located on the DPS PCB. The required local oscillator frequency (i.e. receive frequency minus 45.1MHz) is programmed by the unit central processing system which controls the synthesiser via a 3-wire serial interface bus. The frequency is settable in 6.25 kHz increments (5 kHz optional).

The synthesiser control loop incorporates a low noise op-amp active filter and level shifter, the output of which feeds the voltage-controlled oscillator (VCO). The VCO uses a LC resonator tuned by high-Q varicap diodes to minimise phase noise and jitter. The required local oscillator frequency ranges from 354.9 to 424.9MHz.

The output of the VCO passes through an RF cascade buffer IC, which amplifies the low-level signal from VCO whilst providing high reverse isolation to minimise any variations in VCO loading. The output feeds the splitter network and in turn feed the mixers of each receiver channel.

3.4 TRANSMITTER RF/IF SECTIONS

The transmitter has two channels, each with separate RF, up/down converter, and IF stages. The power supplies and stepped attenuator settings can be independently controlled. A common local oscillator feeds both channels simultaneously. RF output from each channel is by means of a PCB-mounted 50Ω SMB connector. With the exception of the VCO/synthesiser sections the descriptions below apply equally to either transmit channel.

3.4.1 FORWARD SIGNAL PATH

The transmitter employs a fixed frequency 'direct IF' with single up conversion to the final RF. It includes a fixed and manual tuned IF filters to attenuate DAC spurs. The mixer is a quadrature up converter and also provides an image reject function due to 90deg phase splitting of the input signal. The adjustment of gain is provided by a 1.5-33.5dB stepped attenuator programmable in 0.5dB steps. Power amplification follows consisting of devices biased to provide a reasonably linear characteristic to support the required modulation types. A directional coupler on the PA output provides a sample of the signal for the feedback path. The PA bias is controlled via DAC outputs. The PA bias tracks temperature based on a predefined tracking curve. An ADC monitor measures PA final and driver current, forward and reverse power. PA temperature is monitored for each channel by dedicated temperature sensors.

3.4.2 FEEDBACK SIGNAL PATH

The RF signal from the directional coupler has adjustment of gain provided by a 1.5-33dB step attenuator programmable in 0.5dB steps. An image reject mixer provides attenuation of any external signal on the down converter image frequency. The RF signal is down converted to a 15.3835MHz IF feedback signal which is the same as the forward path signal. This IF signal is amplified and summed with the forward path to close the loop.

3.4.3 LOCAL OSCILLATOR

The transmitter local oscillator consists of a programmable fractional-N phase-locked loop (PLL) frequency synthesiser. This uses a stable reference frequency derived from the DPS 40MHz clock. The required local oscillator frequency (i.e. transmit frequency minus TX IF) is programmed via a serial interface bus from the DPS. The LO frequency can be set in 5 kHz increments.

The synthesiser control loop incorporates a low noise op-amp active filter and level shifter, the output of which feeds the voltage-controlled oscillator (VCO). The VCO uses a LC resonator tuned by high-Q varicap diodes to minimise phase noise and jitter. The required local oscillator frequency range is 384.6165MHz to 454.6165MHz (70MHz total).

The output of the VCO passes through a resistive attenuator into a buffer amplifier which raises the power level. This is followed by two Wilkinson splitter networks, resulting in four 50Ω outputs. These outputs feed the up conversion and down conversion mixers for each of the two transmitter channels.

3.4.4 INTERNAL DUPLEXER

The duplexer takes one receiver and one transmitter and duplexes them onto a single antenna port. Two duplexers are used in each radio unit. The antenna port connector is a waterproof N-type. Connections to the receiver and transmitter printed circuit assemblies are made internally via two 50Ω SMB connectors and interconnecting semi-flexible coax cables. Each duplexer has two band pass filters with notches and an LNA for the receive path. The notch frequency of each element is tuned by a trimmer capacitor.

Electrically the two duplexers in each radio unit are identical. Physically they are different and present almost a mirror image of the other. These are referred to as 'Channel 1' and 'Channel 2'. The duplexers cannot be swapped over.

4 SETTING UP ON THE BENCH

The radio units can be interconnected for bench-based testing or configuration. Attenuators with the appropriate value and power handling must be used. The RF wiring diagram shows the interconnection of attenuators, cables and splitters for a standard bench test.

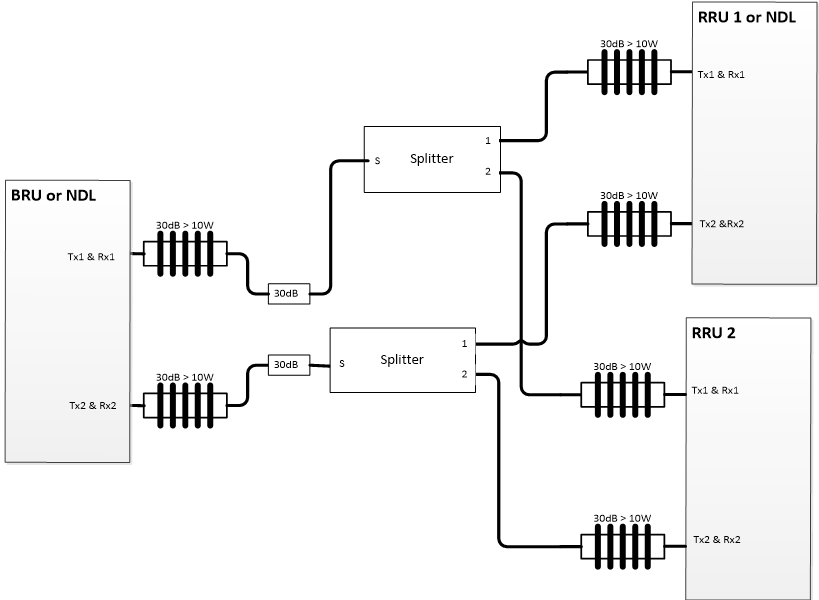

Note: If an NDL system or an MDL system with only one RRU is desired then the splitters, second RRU and corresponding attenuators can be omitted. Mimomax can supply a splitter that provides 4 ports and ~30dB attenuation.

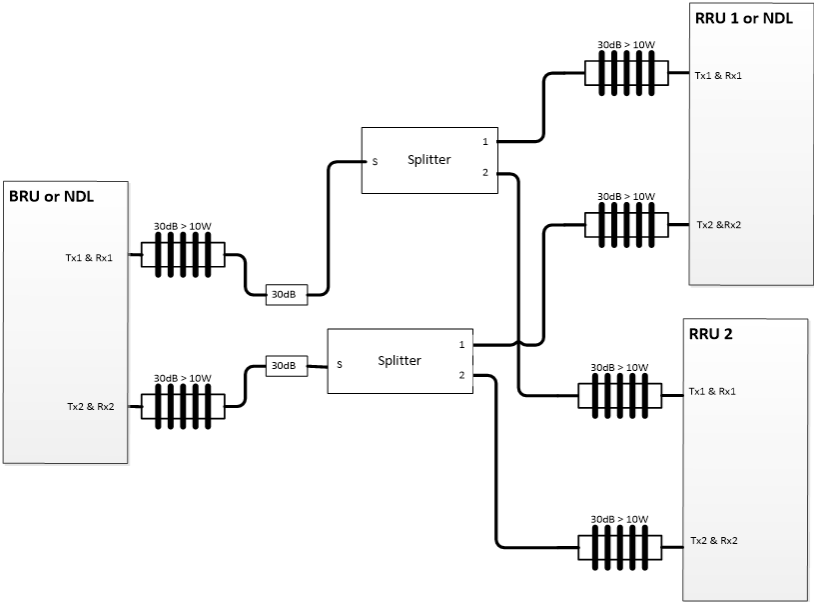

- Recommended equipment:
- 6x high power attenuators (30 dB, >10 W)
 - 2x low power attenuators (30dB)
 - 2x splitters
 - Sufficient cables and adaptors to connect the above devices to the radio units

4.1 TESTING THE NETWORK SETUP

Once the RF setup has been completed the radio units can be powered up, networking on associated devices configured and the units logged into. Refer to the label located on the underside of the radio unit to identify the configured IP address and subnet mask. The image below shows an example IP diagram of the network in Router mode. The following one shows an example of same network in Bridged mode. We generally recommend setting up MDL in Bridged mode because the network settings are simpler however it depends on your IP planning for the multipoint network.

First, we connect to each radio unit locally. To do this, configure the IP address, subnet mask and gateway of the connected device or laptop. It is crucial that the laptops/devices are on the same subnet as the Tornado's and also that their gateway is set to the Tornado's IP address. This means you will need to reconfigure the IP information if moving the laptop between radio units.

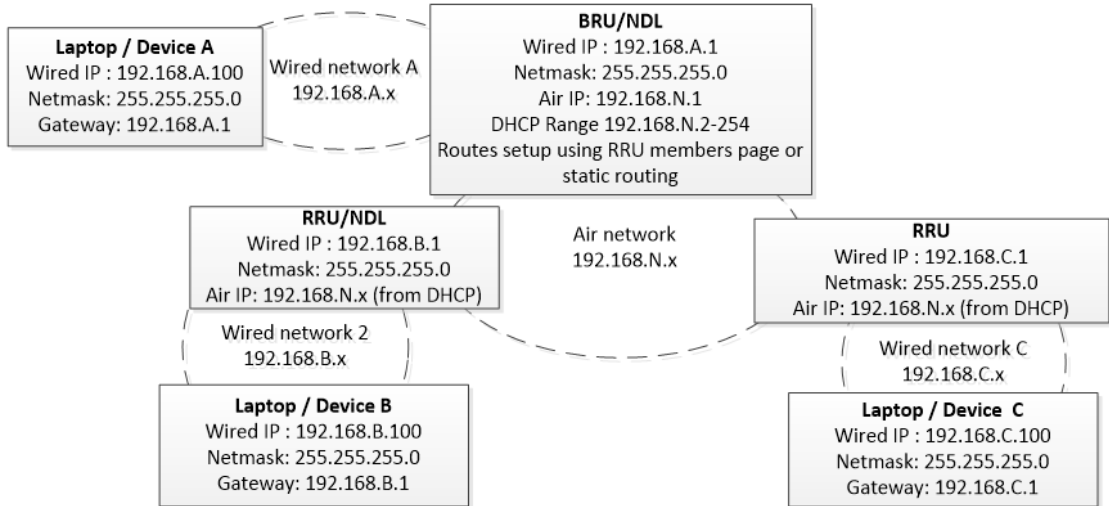

Example IP diagram using 192.168.x.x subnets (Routed mode)

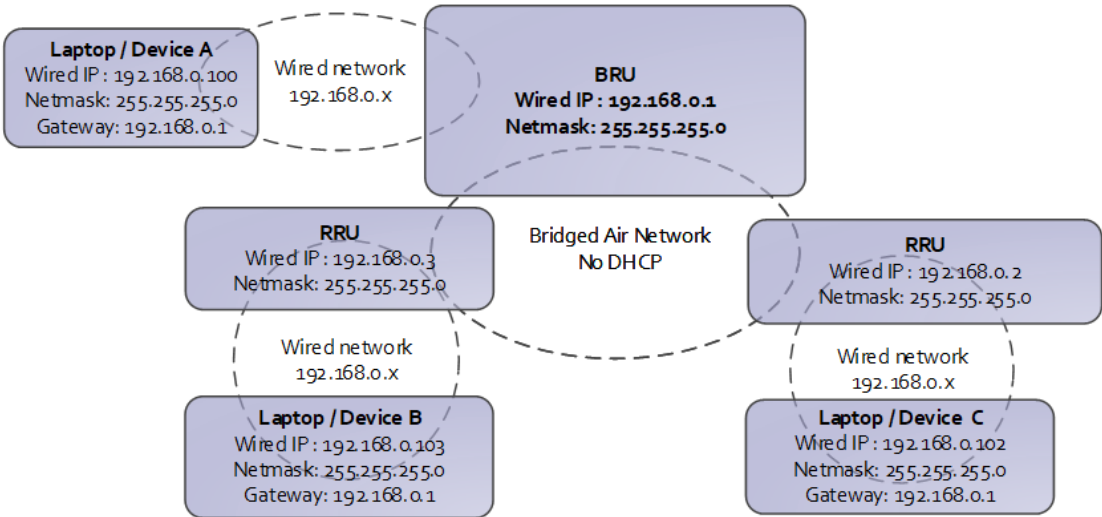

Example IP diagram using a single subnet (Bridged mode)

Next confirm network connectivity by pinging each radio unit from the connected laptop. If this is not successful, use ipconfig to check your networking settings. Once we have network connectivity with the local radio unit, type the appropriate IP address into your web browser to access the unit.

```
C:\>ipconfig

Windows IP Configuration

Ethernet adapter Local Area Connection 9:

    Connection-specific DNS Suffix  . : 
    Link-local IPv6 Address . . . . . : fe80::c5cd:db78:b35d:eccc%35
    IPv4 Address. . . . . : 192.168.0.15
    Subnet Mask . . . . . : 255.255.255.0
    Default Gateway . . . . . :
```

```
C:\>ping 192.168.0.1

Pinging 192.168.0.1 with 32 bytes of data:
Reply from 192.168.0.1: bytes=32 time=1ms TTL=64
Reply from 192.168.0.1: bytes=32 time=1ms TTL=64
Reply from 192.168.0.1: bytes=32 time=1ms TTL=64
Reply from 192.168.0.1: bytes=32 time=1ms TTL=64

Ping statistics for 192.168.0.1:
    Packets: Sent = 4, Received = 4, Lost = 0 (0% loss),
    Approximate round trip times in milli-seconds:
        Minimum = 1ms, Maximum = 1ms, Average = 1ms
```

Figure 1 Ipconfig on the left (In this case the gateway has not been set properly!) and on the right Pinging 192.168.0.1 (the BRU) from Laptop A

You are now ready to log in, configure, and monitor the system.

5 CONFIGURATION CONTROL AND MONITORING SYSTEM (CCMS)

CCMS is web-based software that enables you to connect to a Mimomax radio unit using a web browser such as Internet Explorer, Firefox or Chrome. No application other than a web browser needs to be installed on your PC or laptop. The radio unit serves up the CCMS web pages. For a full list of functions please refer to Mimomax's Tornado CCMS Manual.

6 CHANGING OPERATING FREQUENCY AND POWER CALIBRATION

6.1 INTRODUCTION

Changing operating frequencies of a Mimomax Tornado radio is done via the CCMS. The radio's power will need to be recalibrated and the internal duplexers also need to be re-tuned. Duplexer tuning is covered in Section 7.

6.2 EQUIPMENT REQUIRED: POWER METER

For accurate measurement of average power from Mimomax transmitters a thermistor bolometer type of power meter (e.g. HP435A or similar) is required. Other types of power meter may give inaccurate average power readings when used with Mimomax transmitters and may be suitable only for relative power measurement.

The transmitters are accurately set up in the factory to produce 250 mW average power output. To avoid compromising spectral purity it is very important that the power output be set no higher than this.

6.3 PROCESS OVERVIEW

The process of changing frequencies can be seen below.

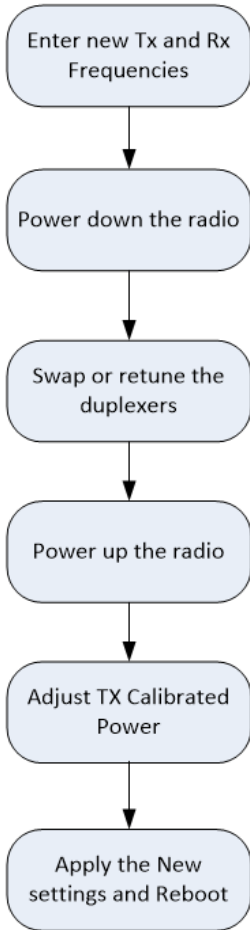

Frequency change process

6.4 CCMS PROCESS

To start the process, click on 'RF TX and Rx'. This page displays the transmitter power level, TX and Rx frequencies. It is strongly advised to set the unit to +24dBm output power and to measure the transmit power before starting the process. This can be used as a reference power should you not have an accurate power meter. The units were factory calibrated to +24dBm, +/-0.2dB.

Simply enter the new TX and Rx Frequencies and/or desired power. Enter save and follow the on screen instructions. The next page is shown below.

A warning appears that requests that the duplexers be re-tuned, and the unit rebooted. This warning will appear on all CCMS pages, and the transmitters will be shut down, until the unit is rebooted.

Configure RF Transmitter & Receiver

Transmitter frequency (MHz)	<input type="text" value="446.26825"/>
Receiver frequency (MHz)	<input type="text" value="441.2625"/>
Transmitter power	<input type="text" value="24"/>
Transmitter power unit	<input type="text" value="dBm"/>
Duplexers	<input type="text" value="Internal"/>

Advanced Configuration

Tracking algorithm rate of adaptation	<input type="text" value="Normal"/>
Tracking algorithm adaptation delay	<input type="text" value="Disabled"/>
Retrain detection time (ms)	<input type="text" value="50"/>

Tx Synth: Locked
Rx Synth: Locked

Configure RF CCMS Page

Once the unit has been rebooted a new warning will appear. It will warn that power calibration is required. Power Calibration should be performed only after Channel 1 and 2 duplexers have been retuned. Ensure that you connect your power meter to the Channel 1 Transmitter then select the Calibration link. Navigate through the drop-down menu to TX Power Calibration. The Channel 1 transmitter will turn on immediately when entering the TX Power Calibration Screen, so it is important to already have the power meter connected.

Configure RF Transmitter & Receiver

Warning: You have entered a frequency which might require duplexer retuning! The system has been decommissioned and unless powered down and retuned might cause impaired operation or permanent damage! Please reboot or shutdown and retune. New settings will be applied after boot-up. You must also re-calibrate Tx Power after boot-up

Transmitter frequency (MHz)	<input type="text" value="445.26875"/>
Receiver frequency (MHz)	<input type="text" value="441.2625"/>
Transmitter power	<input type="text" value="24"/>
Transmitter power unit	<input type="text" value="dBm"/>
Duplexers	<input type="text" value="Internal"/>

Transmitters are OFF
Tx Synth(445.26875): Locked
Rx Synth(441.2625): Locked

Enter New Frequencies Page

6.5 POWER CALIBRATION

The process for calibrating the transmitter power is described below. The process for calibrating the power using CCMS is different from the process when using CLI in terms of what users can do. It is also a subject to constraints

that the UI poses on the user. First select the **TX Power Calibration** from **Calibration** at the main menu. When done the following control is shown:

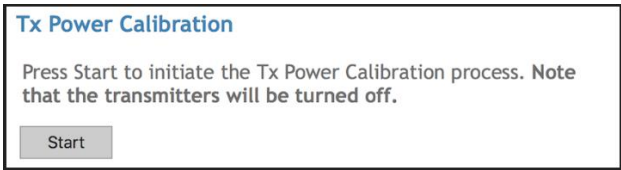

Press **start** to initiate the power calibration.

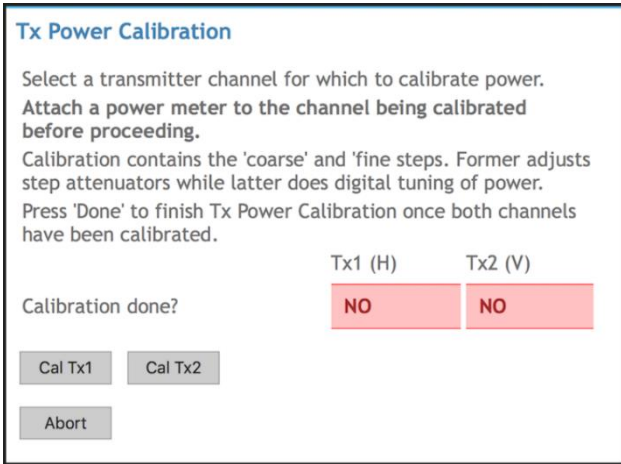

Proceed with **Cal Tx1** to calibrate the 1st transmitter or with **Cal Tx2** to do the 2nd one. The order isn't important. The power at the current state is down and the carrier is turned **On** once one of these buttons is pressed.

6.5.1 CALIBRATING TX (COARSE STEP)

Once we press **Cal Tx1** the carrier power is turned on for transmitter 1 (transmitter 2 is Off) and user is ready to measure output power (uncalibrated output). The following page will allow to input the measured power and perform the 1st step of calibration (the coarse step),

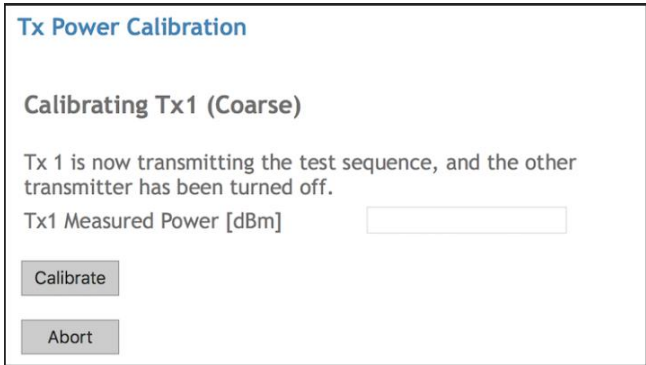

During this step the duplexer loss in the RF EEPROM will be adjusted once **Calibrate** is pressed. This click will take the user to the 2nd calibration step, called the fine step.

6.5.2 CALIBRATING TX (FINE STEP)

The fine step is where the power is accurately adjusted using the PG (aka Pulse Shaper Gain) - the digital gain and digital hardware method to control power. Click Calibrate on the following page to apply it,

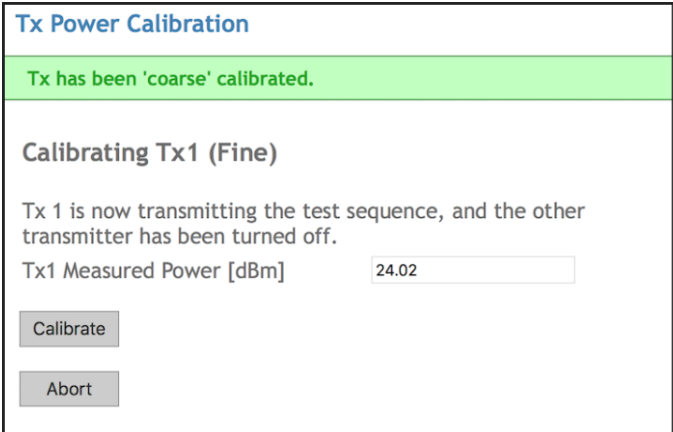

6.5.3 COMPLETE CALIBRATION OF ONE TX

Pressing **Calibrate** the 2nd time, finishes the adjustments and if successful, the following screen will be shown:

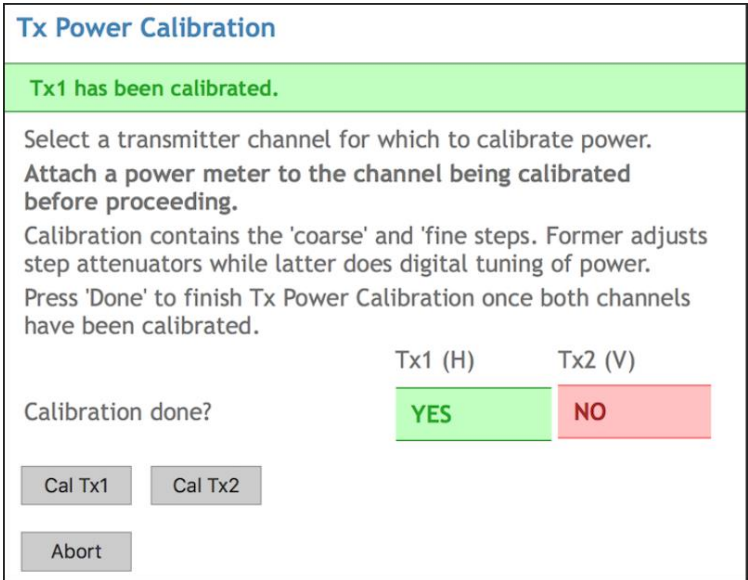

The user can abort the process at any time while still calibrating one of the Tx's by pressing the **Abort** button on this screen or on other process screens. The abort isn't permitted once both transmitters show a green YES on the last screen. This is one difference between CCMS and CLI which allows abort at any time unless you've already issued a confirm.

6.5.4 COMPLETE BOTH TRANSMITTER CALIBRATION

The next page shows up when both transmitters were successful in their calibration.

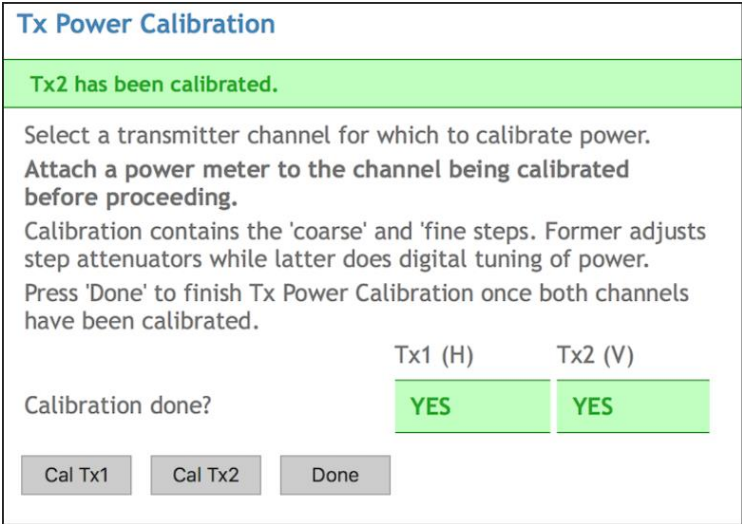

6.5.5 CALIBRATION FAULT

Sometimes, the calibration process can fail. This will occur if the PG is out of range at the fine step. The logic checks the resulting PG against limits and the PG must be inside them for the calibration to pass. On failure of one of the transmitters the following page will be show:

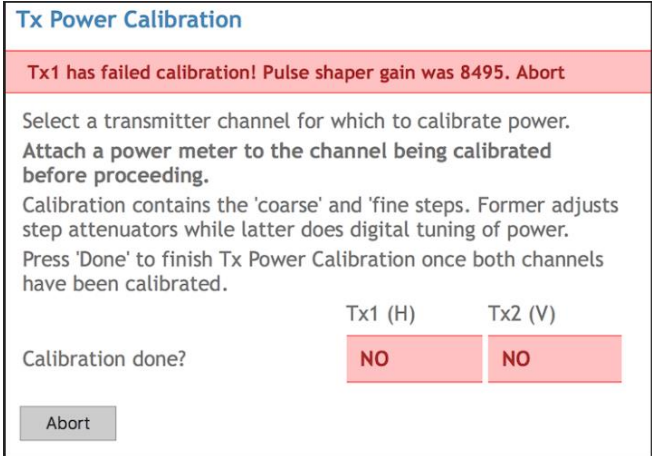

This will result in failure and user will need to abort by pressing the **Abort** button.

7 DUPLEXER TUNING GUIDE

The Mimomax Tornado radio unit has two transmitters and two receivers; these connect to two antenna ports via two duplexers.

The duplexer serves three primary functions.

- It allows one transmitter and one receiver to be connected to a single antenna port.
- It reduces the high-power transmitter signal getting into the sensitive receiver, and the received signal getting into the transmitter.
- In the case of the 400MHz Tornado duplexer, the Low Noise Amplifier for the Receive path has been integrated onto the duplexer printed circuit board.

This manual covers internal duplexer tuning for 400 – 470 MHz radios. 700 MHz radios do not require duplexer tuning and duplexers should not be tuned in the 900 MHz range. VHF radios do not have internal duplexers.

7.1 DUPLEXER TUNING

The 400-470 MHz internal duplexers are designed for a TX to Rx frequency difference of 5MHz or greater. The filters are band pass filters with tuneable notches at +/-the difference in frequency. Given that notches appear either side of the pass band, the duplexer can support TX high or TX low configurations. Note: TX high means the transmitter frequency is above the receive frequency. TX low means the transmitter frequency is below the receive frequency.

The 3dB pass band is nominally designed to be 3.5MHz. However this will vary slightly across the band. It will be slightly wider at the top of the band and narrower at the bottom of the band. The insertion loss is typically 3.4dB in the pass band. Insertion loss will vary across the band, being less at the top of the band and more at the bottom of the band. The Tx notch depth is designed to be >60dB at +/-5MHz. Note that this improves as the other path is tuned up and typically with both Tx and Rx tuned properly the notch depth will approach 65dB.

7.2 400-470 MHZ DUPLEXER TUNING GUIDE

NB: full anti-static precautions are to be taken.

7.3 400MHZ INTERNAL DUPLEXERS

The 400MHz duplexers are band pass duplexers with notches on each of the alternate signal paths. The transmitter path will have a notch tuned to the receiver frequency. The receiver path will have a notch tuned to the transmitter frequency. Each of these Duplexers is made up of ten tuneable elements, five for the transmitter path and five for the receiver path.

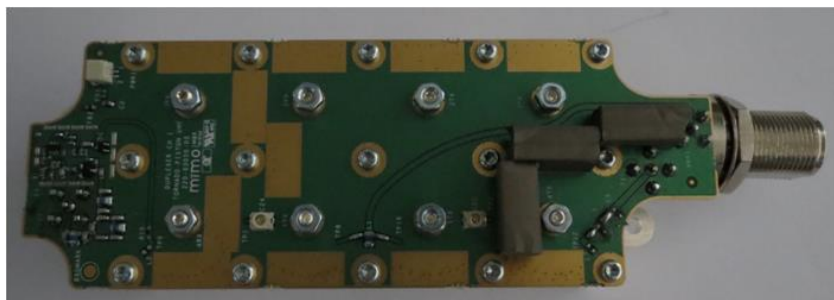

Top View of Channel 1 Duplexer

Channel 2 duplexers are electrically identical, however, from the top view they are considered almost symmetrical about the longest axis. The duplexers are mounted to pillars in the radio housing. M3x10mm T10 Torx head Taptite screws are used to secure the duplexer. The duplexer is further secured through fixing the N-Type connector to the front face of the chassis using the N-Type 19mm hex mounting nut and spring washer.

The duplexer electrically connects to the transmitter and receiver via semi-flexible coax. The coax is terminated in SMB female RF connectors to mate with the opposite gender on the RF and duplexer printed circuit boards. Due to mechanical constraints the duplexers cannot be interchanged between Channels 1 and 2.

The duplexers would be fitted in the chassis as seen below. The symmetry is more obvious from this view. As mentioned earlier, in addition to the normal duplexing function the LNA is integrated into the duplexer. The power supply (+5V) for channel 1 and 2 LNA's are provided by the red and black twisted cable seen connecting the top corner of the duplexers to the RF printed circuit board. In this view Channel 1 is seen on the left side of the radio and Channel 2 on the right. With the radio closed Channel 1 can always be identified as being closest to the green power connector. In addition, Channel 1 is associated with the horizontal polarisation which is indicated on the chassis by an 'H' next to the RF connector.

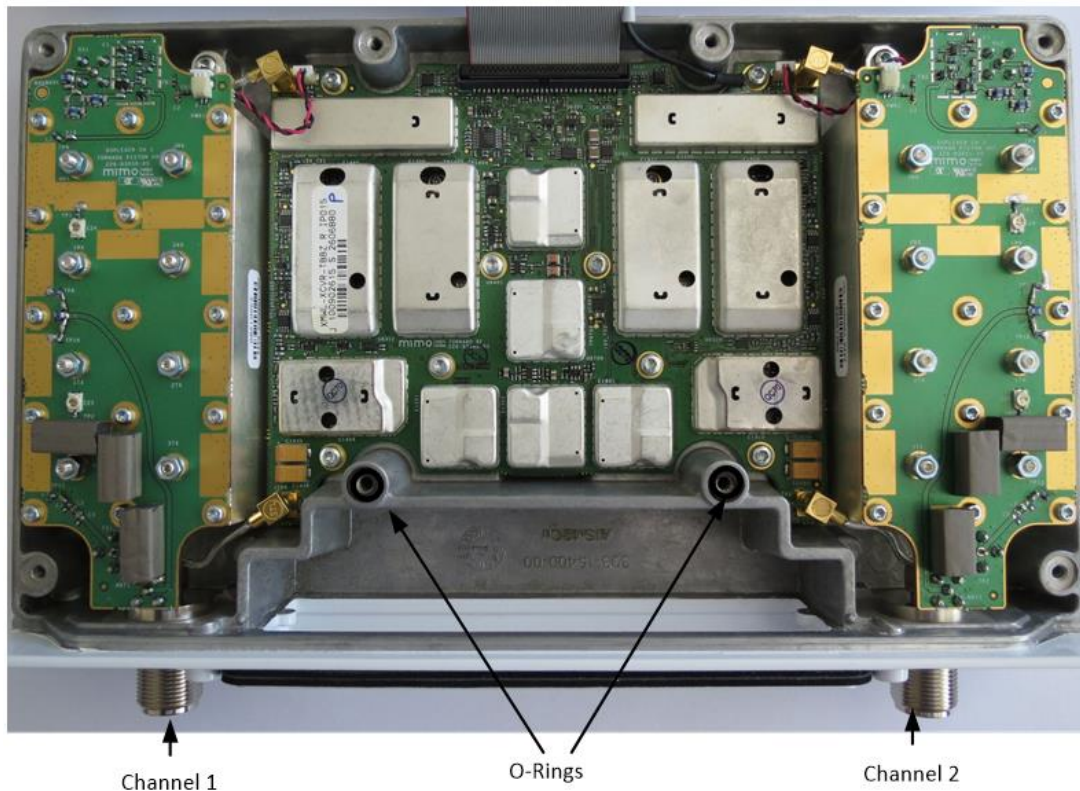

Mimomax Tornado Duplexers in Chassis

There are 3 sub-bands of duplexer to cover the entire 400-470MHz switching range. The sub-bands are 400 - 430MHz, 420 - 450MHz and 440 - 470MHz.

The chassis will need to be opened to gain access to the duplexer. The front panel will need to be removed first. The front panel is fixed to the chassis with two screws. A T8 Torx driver will be required to remove the screws. The eight screws in the chassis can then be removed using a T20 Torx driver. Water sealing within the chassis will need to be preserved. There is a main seal (not shown) that fits within the two halves of the chassis and two rubber O-rings that sit on pillars within the unit as shown above.

7.3.1 TOOLS/EQUIPMENT REQUIRED

- Network analyser or Spectrum analyser with tracking generator or other suitable frequency sweeping set up covering 400 ~ 470MHz
- +5V Power Supply (if removing duplexer from radio)
- Leads and adaptors to connect measuring equipment to type N female and type N Male and the load to SMB male
- 50ohm SMB load
- Fine blade tuning tool for Notch Trimmer, recommend Voltronics TT-400
- Long nose pliers for removing the RF semi-flexible coax connectors
- T6 Screwdriver for Tuning Slugs
- T8 Screwdriver for removing Front Panel

- T20 Screwdriver for removing Chassis Screws
- 5mm Spanner for Tightening Lock Nuts
- Callipers to check slug height
- T10 Screwdriver (if removing duplexer from chassis, duplexer mounting screws)
- N-Type 19mm Hex Socket (for removing duplexer from chassis, N-type nut removal)

7.3.2 PROCEDURE

1. Remove the 8x T20 screws from the perimeter of the radio.
2. Pull the 2 clamshell halves away from each other, separating them at the interface end and pivoting at the other end. Ensure that you don't lose the two small O-ring seals which sit on chassis pillars as shown above.
3. Disconnect the 4x SMB connectors from the RF Board. Long nose pliers are the best tool to remove the connectors otherwise it can be difficult to grip the connector. Don't simply pull or lever up the cable as this will damage the coax at the SMB interface. You can use the SMB connectors on the semi-flexible coax as the test interface by using the appropriate SMB male adapter. This can be more convenient than removing the entire duplexer from the chassis.
4. Calibrate/set up the network analyser to the desired frequency band. It helps to limit the source power to -15dBm so as not to overload the LNA in the Rx path.

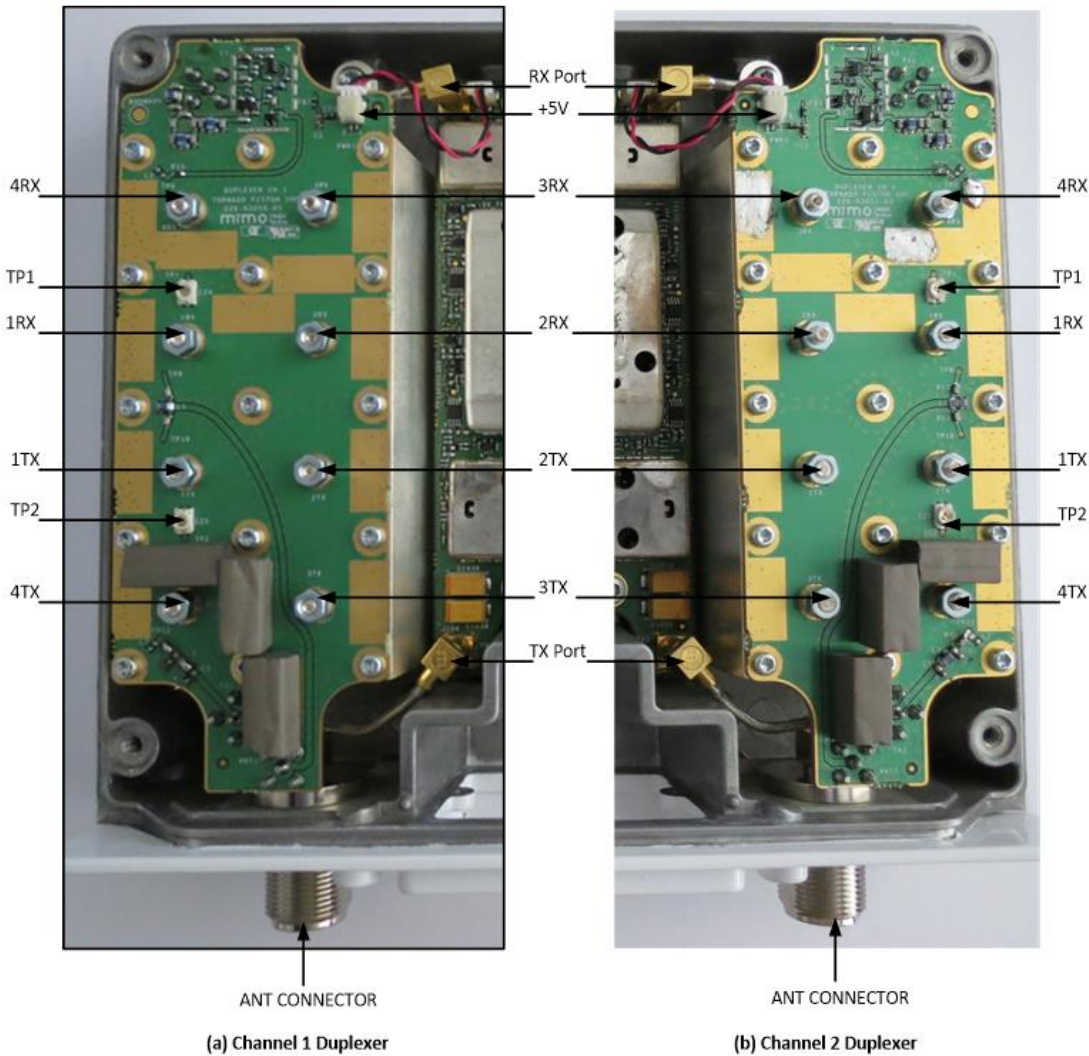

Channel 1 and 2 Duplexer

7.3.1.1 To Calibrate The TX Side

1. Refer to the above figure. Connect Port 1 to TX Port, connect Port 2 to Antenna Port, Connect 50ohm Load to Rx Port, Connect +5V (If you keep the duplexer in the chassis, with +5V connected, you can use the radio +5V by powering the radio unit during calibration).
2. Ensure TX and Rx duplexer is completely detuned away from the frequency of operation.
3. With TX frequency set to marker 1, Tune 2Tx to peak at marker 1 (note #TX represents the tuning slug and is marked on the printed circuit board). **When tuning ensure that the slug height is not greater than 5.6mm higher than the printed circuit board, otherwise the slug will contact the chassis.**
4. Tune 3TX peak such that two peaks are centred around Marker 1
5. Tune 1TX and 4TX such that the pass band (S21) and return loss (S11) are within acceptable limits. Acceptable limits will vary across the band. As a guide a pass band loss of approximately 3.4dB and return loss of greater than 18dB are considered acceptable.
6. Tune notch trimmer, TP2, such that Marker 2 is in the centre of the notch. You should target at least 60dB of notch rejection; however, this will increase to approximately 65dB of rejection when the Rx side is tuned.

7.3.1.2 To Calibrate The Rx Side

1. Ensure the source power from the VNA is less than -15dBm for the Rx port to avoid overloading the LNA on the duplexer printed circuit board.
2. Connect Port 1 to the Antenna Port, connect Port 2 to Rx Port, connect a 50ohm load to TX Port, Connect +5V.
3. Ensure Rx is completely detuned.
4. Tune 2RX to peak at Marker 2.
5. Tune 3RX to peak such that two peaks are centred around Marker 2.
6. Tune 1RX and 4RX such that the pass band (S21) and return loss (S11) are within acceptable limits. Acceptable limits will vary across the band. As a guide a pass band gain of approximately 10.5dB and return loss of greater than 15dB are considered acceptable.
7. Tune notch trimmer, TP1, such that Marker 1 is in the centre of notch. You should target at least 50dB of notch rejection. In addition to the gain of 10.5 the total notch rejection relative to the pass band will be greater than 60dB.
8. Recheck TX Tuning to ensure that the Rx hasn't upset the match and to confirm that the TX notch depth is approx. 65 dB or greater. If the TX match has changed it is likely that 1TX will need to be re-tuned to correct for the Rx interaction.
9. Once both channels have been re-tuned then reconnect the four duplexer coax cables to the RF board, reconnect +5V and assemble the chassis. **Ensure the two O-ring seals are fitted and the main radio seal around the perimeter of the unit is seated firmly in its channel on the digital side of the clam shell. Once the radio is reassembled proceed with power calibration as per Section 6.5.**

7.4 RSSI CALIBRATION

The RSSI and AGC control voltage are in linear relationship, as shown in formula 1.

$$\text{RSSI} = A \times \text{Vagc} + B \quad (1)$$

Where A represents the slope of the curve and B is the offset.

NOTE: The RSSI reading has an uncertainty of +/- 1.5dB

To find out A and B value we need two points (RSSI1, Vagc1) and (RSSI2, Vagc2), which are obtained by applying -40dBm and -60dbm signal at the receiver and recording the AGC voltage respectively.

RSSI calibration can be easily achieved by following the instructions step by step. Below is the summary of the procedure that is also shown on the RSSI Calibration page below (Calibration > RSSI Calibration).

1. Connect signal generator via a 30dB attenuator to Channel 1 receiver.
2. Set signal generator level so that -40dBm can be measured at the receiver input. Choose un-modulated carrier for the input signal.
3. Select Rx1 in the CCMS page.
4. Select -40dBm in the CCMS page.
5. Click Read in the CCMS page.
6. Set signal generator level so that -90dBm can be measured at the receiver input.
7. Select -60dBm in the CCMS page.
8. Click Read in the CCMS page.
9. Click Calculate in the CCMS page.
10. Click Save in the CCMS page.
11. Connect signal generator via a 30dB attenuator to Channel 2 receiver.
12. Repeat Step 2 to 10 for the Channel 2 receiver.

RSSI Calibration

The calibration process for the RSSI:

Calibrate to find two points A,B to create an RSSI curve using linear formula $y=Ax+B$ [V]

1) Connect SigGen to a receiver

CAUTION! 30dB (>25W) power attenuator is recommended between the SigGen and the receiver as transmitter may operate and damage the SigGen.

2) Set SigGen to obtain -50dBm and then -90dBm signal level at receiver, un-modulated carrier.

Select -50dBm then press Read, then select -90dBm and press read again before pressing Calculate!

3) Select receiver Rx2 ▾

4) Select input signal power -90dBm ▾

5) Click to read AGC value

AGC Lo value (V)

6) Repeat 4,5 for other power level if done for -50dBm

7) Click to calculate

Calibration point A (V)

Calibration point B (V)

8) If the numbers look within range then click Save.

This will save to the Configuration database.

9) Repeat for next receiver channel

RSSI Calibration Page

7.5 REFERENCE CALIBRATION

For the radio to maintain an accurate frequency reference calibration of the radio's frequency reference is recommended to be checked after three years.

7.5.1 EQUIPMENT REQUIRED FOR REFERENCE CALIBRATION

- An accurate 10 MHz source is needed, with a level between -5 and +20 dBm
- A Mimomax GPIO/Ref/Alarm cable
- A connection to the radios CCMS

7.5.2 HOW TO CALIBRATE THE REFERENCE

1. Feed the 10 MHz source into the reference inputs of the GPIO/Ref/Alarm connector (Brown and Red wires on the Mimomax GPIO/Ref/Alarm cable). Note: the reference signal is differential, but it does not normally cause any problems if a non-differential signal is used, treat one of the differential connections as ground in this case.
2. In CCMS, navigate to 'Calibration' > 'Reference Calibration'.
3. Click 'Start'.

If the calibration is successful the message, 'A 10 MHz reference has been found. The calibration process was successful' will be displayed.

Reference Calibration

Attach the 10MHz reference to the external reference input.
Use pins 10 and 11 of the GPIO/REF/ALARM connector.

Press Start to start the reference calibration process ...

Start

Reference calibration

8 RADIO REFERENCE INFORMATION

8.1 MECHANICAL DIMENSIONS AND MOUNTING

This section describes the dimensions of the Tornado radio unit and the various methods of mounting.

8.1.1 DIMENSIONS

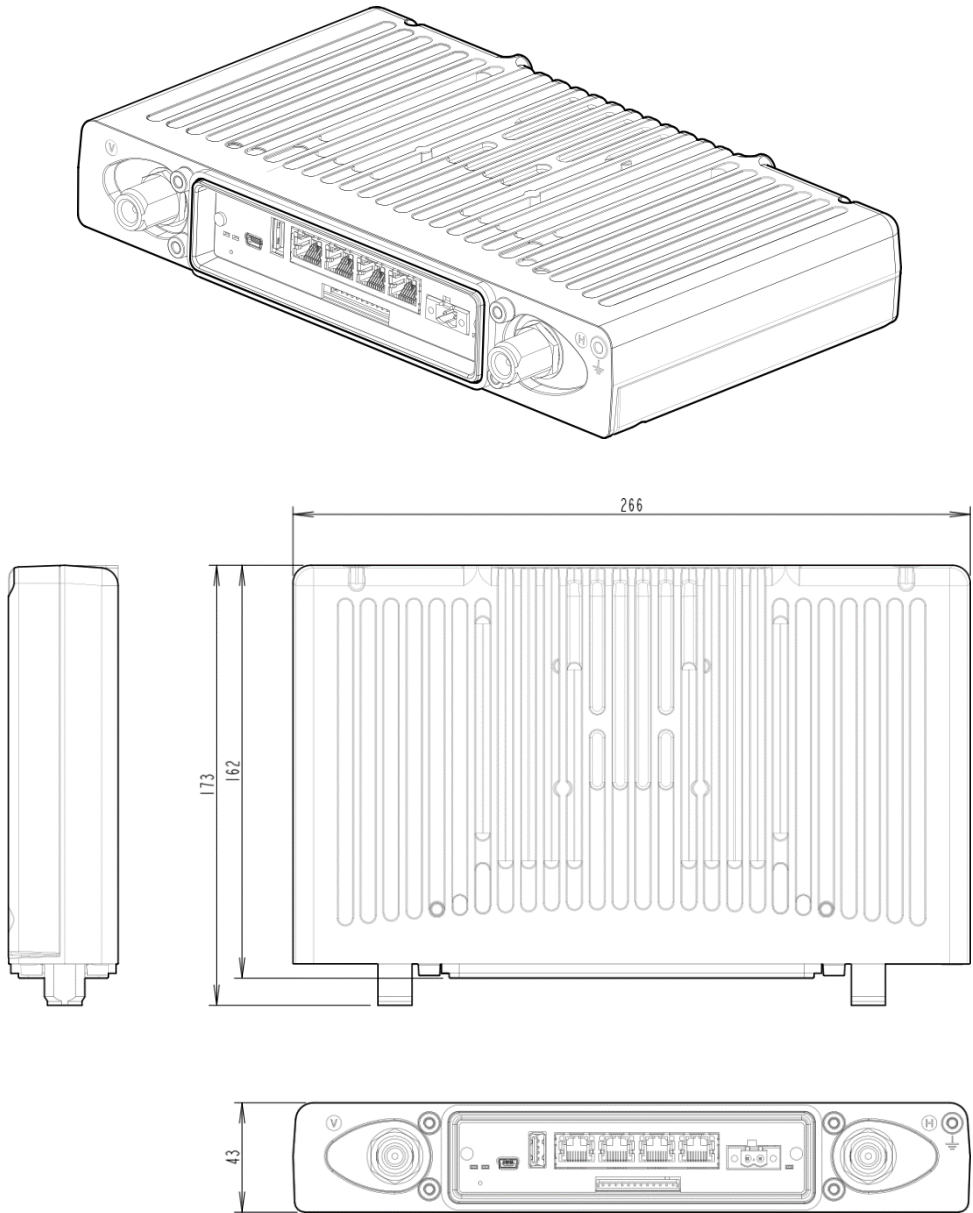

Mechanical Dimensions (All units are in mm)

8.1.2 MOUNTING

The radio unit can be mounted in Rack, Pole, Wall or DIN mount configurations. Each of these styles of mounting can be further customised further by collocating or separating aspects such as batteries and power supplies. There are advantages and disadvantages for each scenario.

8.1.1.1 Rack Mount

The Rack mount kit is designed to be used to mount the Tornado into a standard 19" rack enclosure, occupying 1U of rack height. Tools required are a #2 Philips screwdriver.

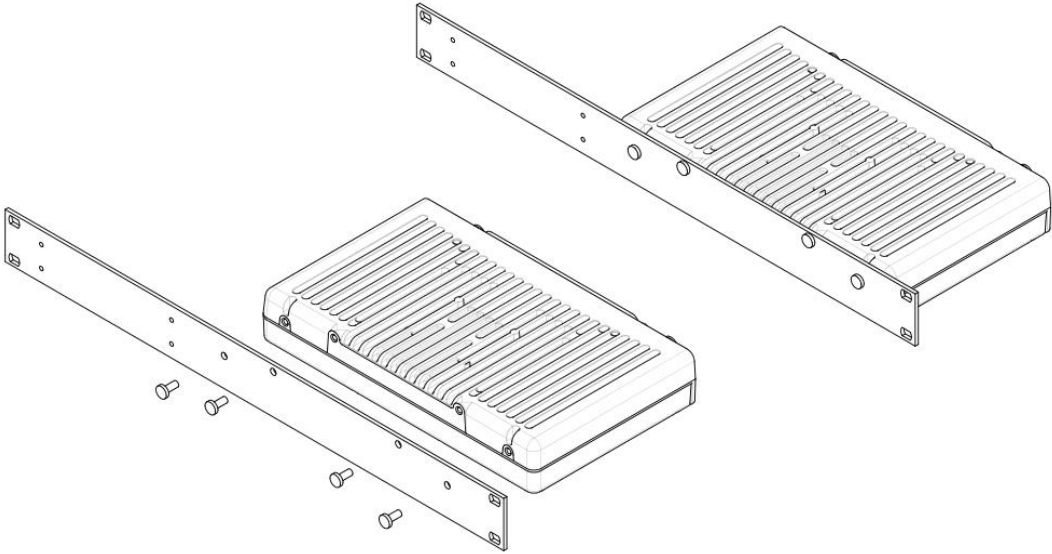

Assembled and exploded view of the Tornado rack mount

8.1.1.2 Pole Mount

The pole mount kit can be used to mount the tornado onto a pole with a diameter between 23 and 51 mm. If the tornado is mounted outside, then the weather proof hood must be used. Tools required are a #2 Philips screwdriver and a 10 mm spanner.

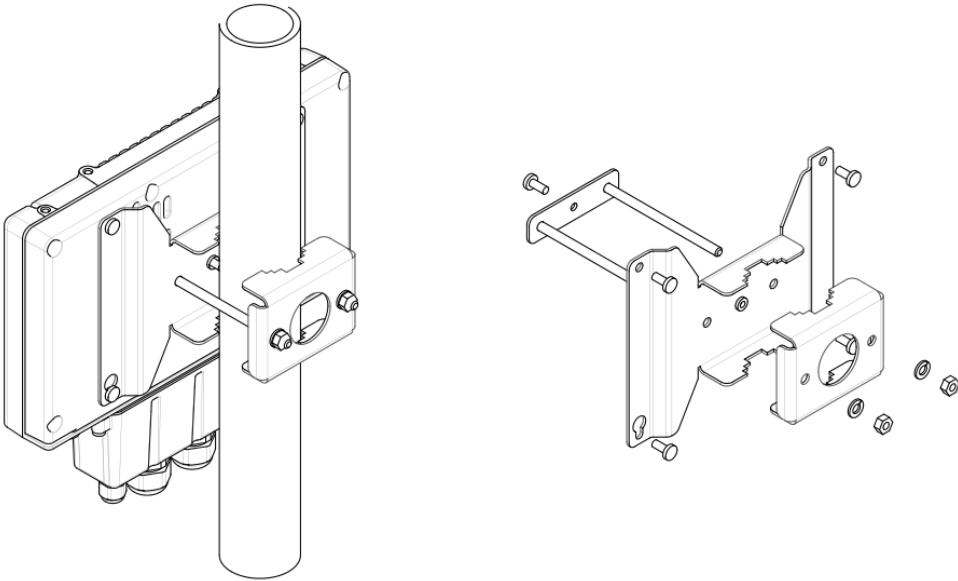

Assembled and exploded view of the Tornado pole mount

8.1.1.3 Wall Mount

The wall mount kit can be used to mount the Tornado to an existing structure, or even to a large diameter wooden pole. If the Tornado is mounted outside, then the weather proof hood must be used.

Tools required are a #2 Philips screwdriver, and R2 square drive. The supplied wall screws are of 'Walldog' type. They do not require a drill bit for wood, but a 5mm drill bit will be required to insert the mounting screws into concrete, brick or stone. A 5.5mm masonry bit may be required for especially hard material.

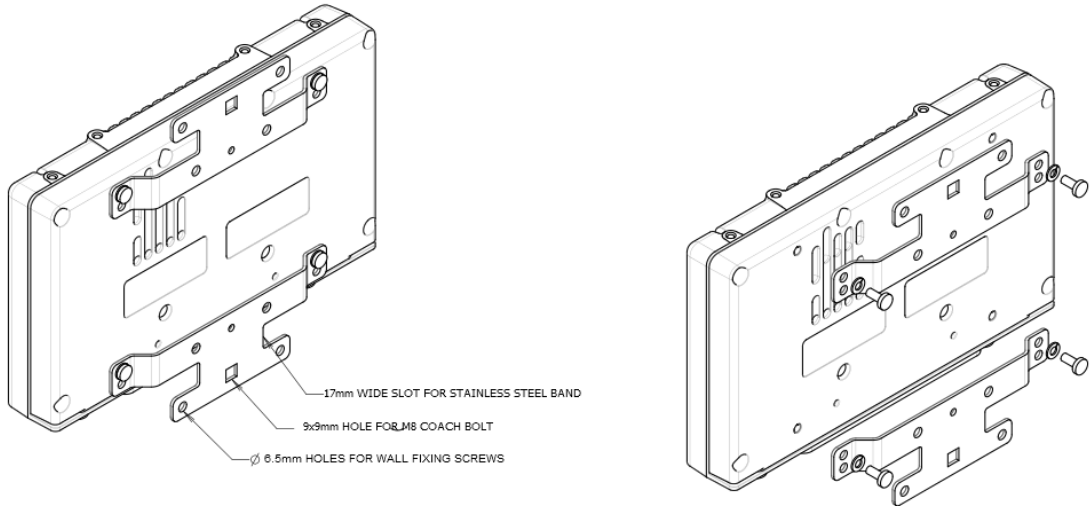

Assembled and exploded view of the Tornado wall mount

8.1.1.4 DIN mount

The Tornado can also be mounted to a Top hat style DIN rail (EN 50022). Tools required are a #2 Philips screwdriver.

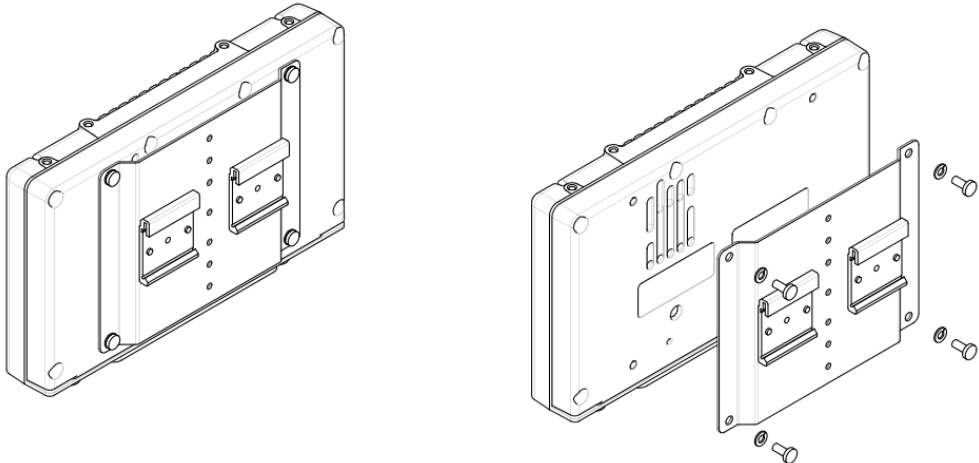

Assembled and exploded view of the Tornado DIN mount

8.1.1.5 Weatherproof hood

The weatherproof hood can be used to protect the Tornado interfaces from dust or moisture ingress. It needs to be used whenever the unit is mounted in an outdoor environment or in adverse conditions.

When installing the hood, orientate it so that the power label on the hood is on the same side as power label on the radio unit. Do not over tighten the screws or glands. The Tornado then is to be mounted vertically with the glands oriented downwards, as seen below.

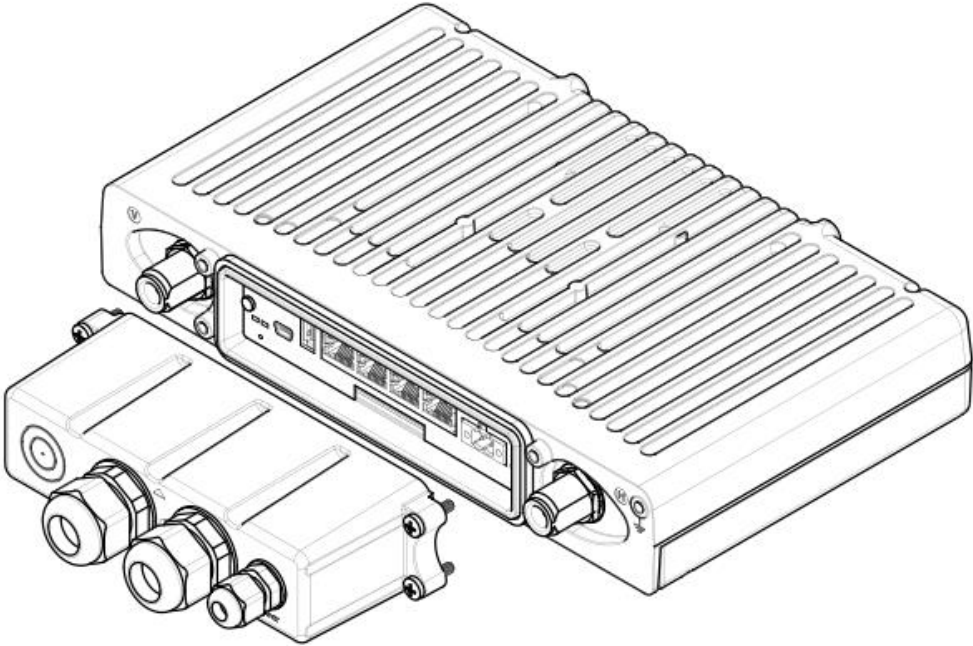

Exploded view of the weatherproof hood

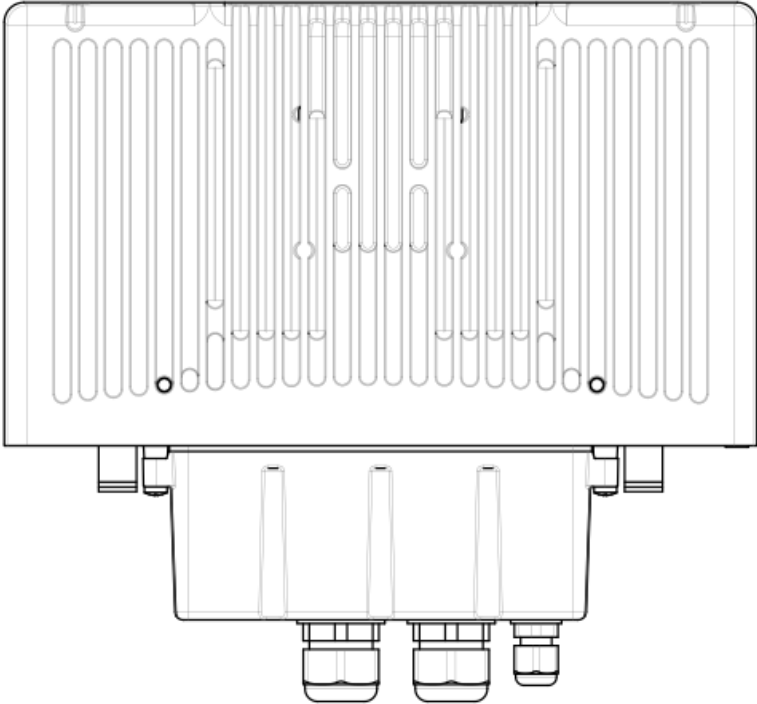

Mounting orientation of the weatherproof hood

8.1.1.6 Mounting holes

If other mounting options are desired, the mounting holes described as shown below can be used directly. Ensure that bolts of the correct diameter and depth are used, otherwise damage may occur.

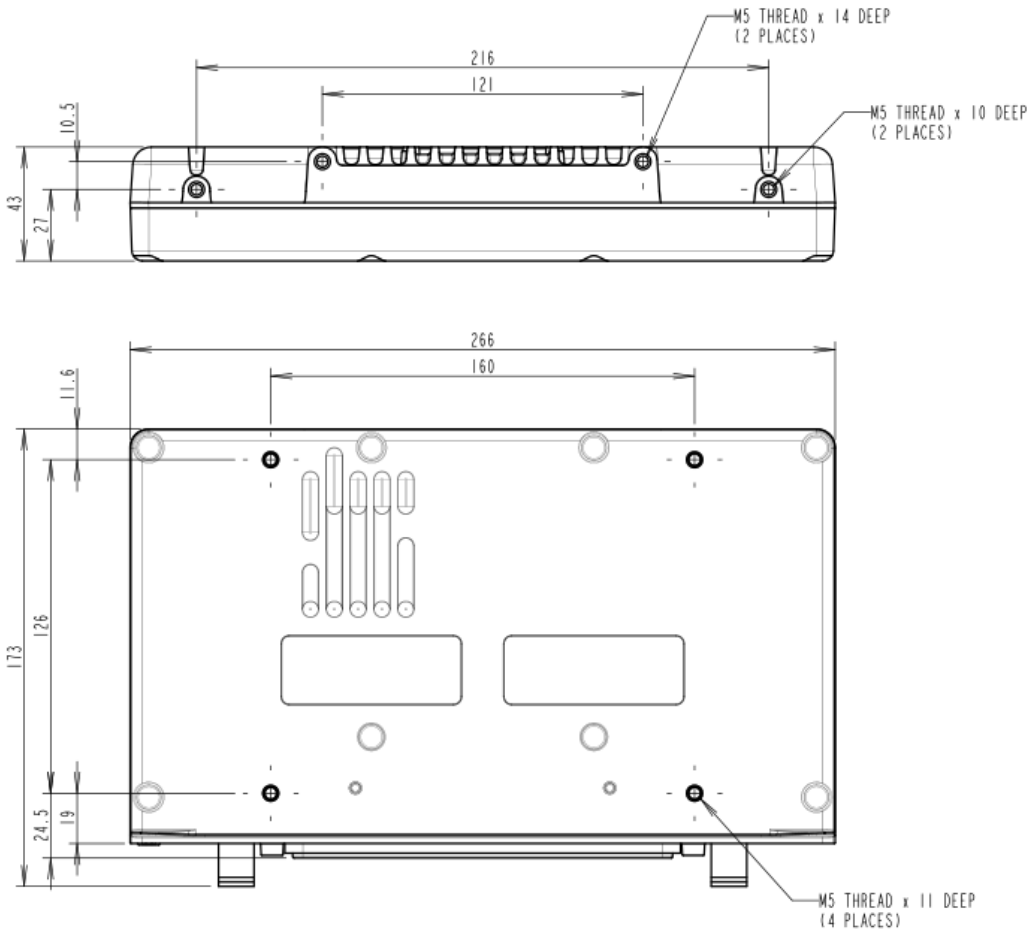

Mounting hole size, depth and location

8.2 INPUT AND OUTPUT

This section describes the general I/O of the device. It includes an overview of all connectors as well as LED's and other relevant electrical parameters. Refer to the Tornado serial manual for detailed information on the use of the serial interfaces.

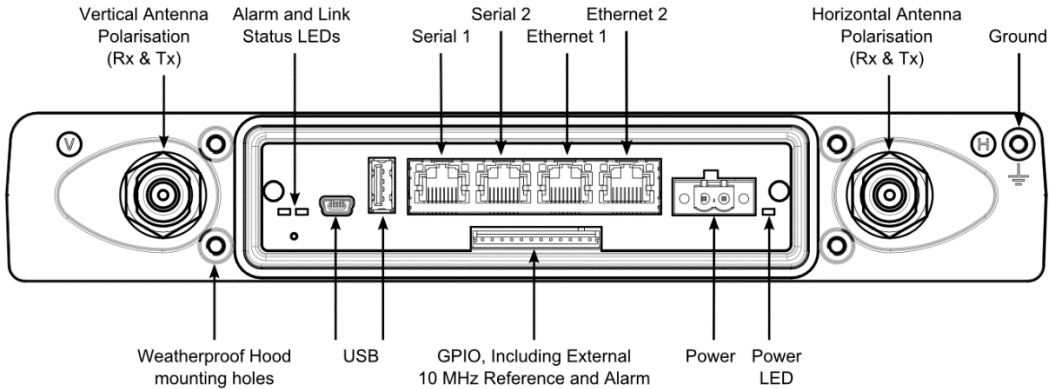

Radio Connections and LEDs

8.2.1 CONNECTORS

Antenna/Duplexer ports (2x N connectors)

The radio unit is a 2x2 MIMO unit with internal duplexers. This means each N connector is both a transmit and a receive port. In order to aid in diagnostics, the left port should be connected to the vertical antenna polarisation while the right port is connected to the horizontal polarisation.

Be careful that feeders connected to the N connectors are not over tightened.

Ethernet

Two shielded RJ45 sockets provide the Ethernet connection(s). Shielded cable is not normally required.

Serial

Two shielded RJ45 sockets provide serial port connection.

Power connector

A Phoenix Contact MSTB 2, 5 HC connector provides the Power Connection.

GPIO

A JST S12B-EH connector has the GPIO, Alarm and Reference connections.

Earth

A chassis earth point is provided.

USB host (USB-M)

An A-type USB connector provides the connection to the USB host port (software support will be developed in the future).

USB device (USB-S)

A mini B type USB connector provides the connection to the USB device port (software support in future).

8.2.2 LED BEHAVIOUR

Power LED (Green)

The power LED is located on the right of the front panel. The LED lights up when power is applied.

Link LED (Green)

NDL: The Link LED lights up when an RF link is active.

RRU: The Link LED has four different modes of operation each indicating a different RF link state. It is off when the RRU is not detecting a signal from the BRU. It will flash with a 50 percent duty cycle at 1 Hz when the radio is synchronised with the BRU. A pattern of two flashes followed by a gap will repeat at 1 Hz once a downlink is established. And finally, it will be constantly on once a full duplex link is established.

BRU: The Link LED operates with a time out of approximately two minutes. Every time communication occurs between the BRU and one of its RRUs the timer will reset. Regular communication between the units will be indicated by this LED remaining on.

Alarm LED (Red)

During boot up (proximally 10 seconds after power is applied) the LED will flash at a rate of 1Hz to indicate that the radio is in its boot up process.

Once boot up is complete, the LED will flash when the radio is in an Alarm state.

Ethernet LEDs

Each Ethernet port has a green and an orange LED. The green LED flashes when the port is receiving data. The orange LED is off when the port is 10 Mbit/s and on when it is 100 Mbit/s.

8.2.3 ESSENTIAL POWER REQUIREMENTS

8.2.3.1 Voltage Range

The operating input voltage range of the power supply is 10.5 to 60 VDC. This means that the voltage must not rise above 60 VDC under idle conditions or fall below 10.5 VDC at full load.

8.2.3.2 Static Power Input

The typical power drawn when the transmitter is active is about 21W (maximum 26W). This occurs when the two transmitter channels are operating at full power. The power drawn via the internal switching regulators is nearly independent of supply voltage, except for some additional converter loss at the top end of the voltage range, so that the input current to the RU is almost inversely proportional to supply voltage, e.g. approximately 2.4A at 10.5V or 0.5A at 56V This needs to be considered when the power source is remote from the RU and cable loss is a factor.

Input Source Voltage (S)	Average Current in Amperes = $I_{avg} = 25/S$	Circuit Breaker Current in Amperes = $I_{mcb} = 1.5 \cdot I_{avg}$
10.5 Volts	2.4 Amps	3.6 Amps
24 Volts	1.1 Amps	1.7 Amps
48 Volts	0.6 Amps	0.9 Amps
56 Volts	0.5 Amps	0.8 Amps

Table 1: Current draw

8.2.3.3 Starting Current

As long as the power supply can supply the static power it should be able to provide sufficient current during start-up.

8.2.3.4 Supply Polarity (Isolated Power Supply)

Both the positive and negative connections of the power supply are isolated from the case and other circuitry. The standard DC power cable supplied with an RU is twin 1.5mm (16AWG), approximately 2m long, terminated at the RU end with a Phoenix Contact MSTB 2,5 HC plug. This cable is wired to pins 1 (positive) and 2 of the plug, which employs screw terminal contacts.

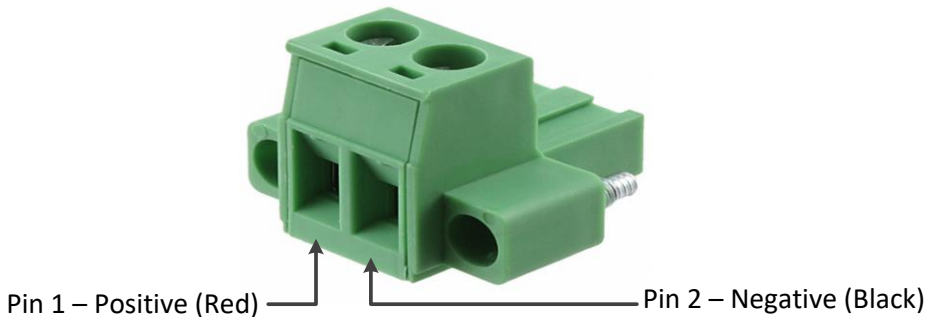

Power supply connector

8.2.3.5 Grounding

The radio unit case must be grounded through an external earth strap. Generally, this is done to the local rack frame, which in turn should be part of a well-designed station grounding system. This internal grounding is designed for EMC and transient protection currents. The RU casting is tapped to take a M4 x 8mm screw for grounding purpose.

8.2.3.6 Supply Noise

Regardless of the EMC provisions in the equipment, power wiring from the DC source should not be shared with other equipment that may introduce excessive noise. Nor should the power cables to the RU be run alongside cables that connect to other equipment that may produce high current noise or transients, e.g. power relays.

8.2.3.7 Operating from AC Mains:

AC-DC 'desktop' power supplies are available from Mimomax with the required power.

8.2.3.8 Choice of power supply cable size

The table below indicates the maximum length of cable that can be used for given supply voltages and cable sizes. It also includes the maximum loop resistance, so that other combinations can be checked.

Cable length was calculated for 80% power transfer efficiency (or 10.5 volts at the radio, in the case of a 12V supply) with a 26-watt load and supply Vmin. The value used for resistivity of copper was at 70 Celsius. This table is a guide only. Always check the cable manufactures data before detailed engineering.

Cross sectional area (mm ²)	Approx. AWG	Supply voltage		
		12V (Vmin = 11v)	24V (Vmin = 18v)	48V (Vmin = 36v)
1.85	14	9m	92m	369m
2.5	13	13m	125m	
4 ¹	10	20m		
6 ¹	8	30m		
Max loop resistance		0.2 Ω	2.0 Ω	8 Ω

Table 2: Recommended maximum cable length for a given supply cable size

Note 1: The Phoenix Contact MSTB 2,5 HC plug can support stranded wire with a cross sectional area between 0.2 mm² and 2.5 mm² Longer cable runs will therefore need to use a distribution block, and cable with a smaller size for the final connection.

8.2.3.9 Power over Ethernet

The Tornado product supports passive power over Ethernet through the use of external splitters and injectors, these devices use the spare Ethernet pairs on Cat5 cable (or better) to carry the power supply passively to the radio over the Ethernet cable.

If the Ethernet cable greater than 20m is used a supply voltage of 48V should be used, at a distance of 20m or less a 24V supply can be used. The supply current should be kept under 1A when using power over Ethernet including accounting for voltage drop over the cable. A 48V AC-DC power supply suitable for use with the Mimomax implementation of PoE is available.

The PoE Injector shown below is used to introduce the DC power to unused pairs. The PoE and splitter is then used to separate the Ethernet and power feeds from the Cat5 cable and provide them to the radio. A splitter with a sealed connector in conjunction with the weather proof hood (shown below) can be used to provide a waterproof connection to the radio. This allows a single Cat5 cable to be run to an outdoor mounted radio.



PoE Injector

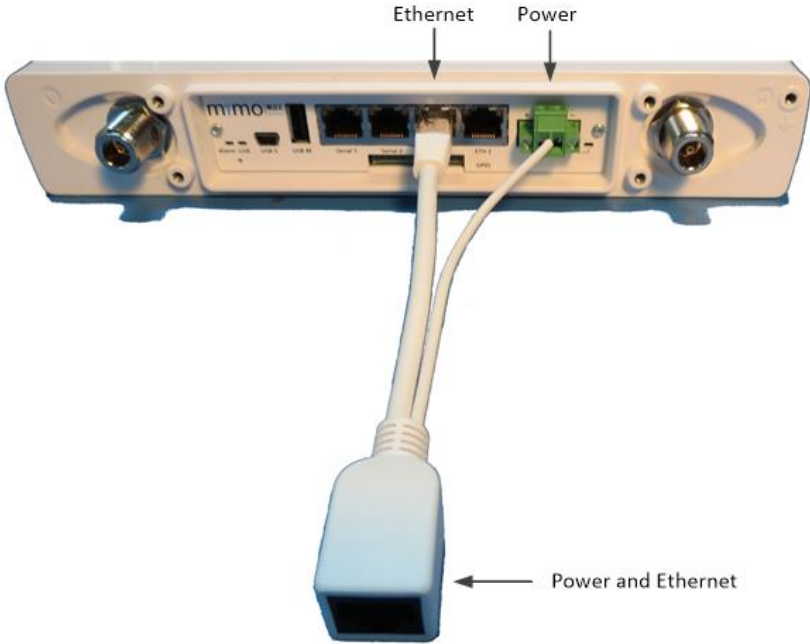

PoE Splitter

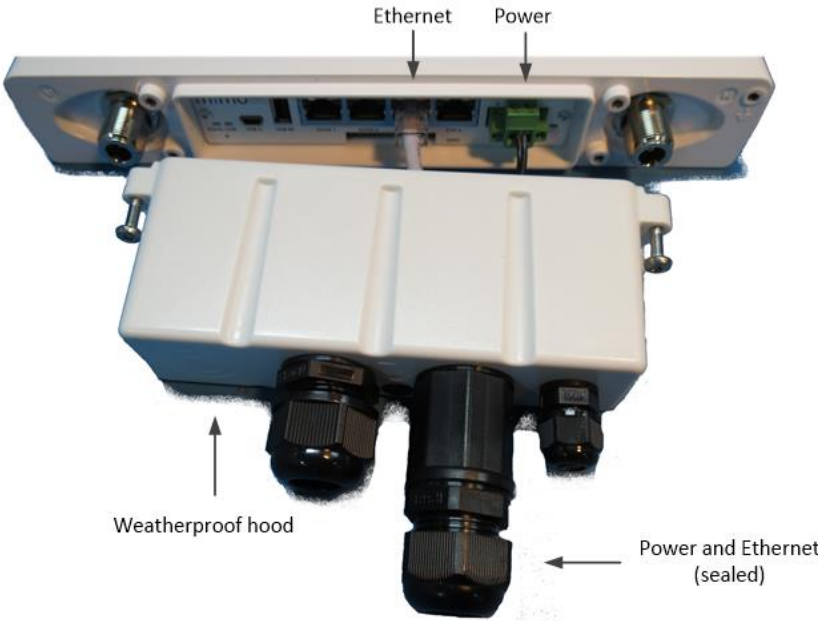

Sealed PoE Splitter

8.2.4 ELECTRICAL CHARACTERISTICS

Parameter	Conditions	Min	Typical	Max	Units
Power supply					
Input voltage	Normal operation	10.5		60	V
Power Consumption	Idle, Tx off		5.5	7.6	W
Power Consumption	Tx Active		20	26	W
Ethernet					
Tx Peak Differential voltage	100Base-Tx, 100 Ohm termination		1.00	1.05	V
Tx voltage imbalance	100Base-Tx, 100 Ohm termination			2	%
Tx Rise/Fall time	100Base-Tx	3		5	ns
Tx Rise/Fall imbalance	100Base-Tx	0		0.5	ns
Tx duty cycle distortion	100Base-Tx			+/- 0.5	ns
Tx Overshoot	100Base-Tx			5	%
Tx Output Jitter	100Base-Tx, Peak to Peak		0.7	1.4	ns
Tx Peak Differential voltage	10Base-T, 100 Ohm termination		2.4		V
Tx Output Jitter	10Base-T, Peak to Peak		1.4	11	ns
Rx Squelch Threshold	10Base-T, 5MHz square wave		400		mV
Serial					
Output Voltage swing	Loaded with 3kOhms to ground	+/- 5	+/- 5.4		V
Output short circuit current		-60		+60	mA
Input Voltage		-25		+25	V
Input Low Threshold	Temperature ambient = +25	0.8	1.5		V
Input High Threshold	Temperature ambient = +25		1.8	2.4	V
5VPC Output Current	200			200	mA
GPIO					
Input voltage	Input	-0.3		60	V
Current Sinking Capability	Output driving low			100	mA
Input Impedance			109		kOhms

Alarm					
Input current (max)				300	mA
Switching voltage (max)				33	VDC
<i>Parameter</i>	<i>Conditions</i>	<i>Min</i>	<i>Typical</i>	<i>Max</i>	<i>Units</i>
Reference input					
Level		-5		+20	dBm
Frequency			10		MHz
Reference output					
Level			0		dBm
Frequency			10		MHz
USB Host					
VBus Output Current				400	mA
Input voltage	Voltage on Dm and Dp pins	-0.3		5.25	V
USB Device					
Input voltage	Voltage on Dm and Dp pins			5.25	V
Vbus	Voltage on VBus pin			5.5	V

Table 3: Electrical characteristics

8.2.5 INTERFACE PORTS

The radio unit has Ethernet and asynchronous serial interfaces as well as a General-Purpose Input/Output (GPIO). The GPIO connector incorporates an alarm and external reference. Various synchronous serial standards are also supported via external converter boxes. The serial pin out is briefly described in this document. Please refer to the Tornado serial manual for detailed information on configuring the unit’s serial interfaces.

8.2.5.1 Ethernet

The radio unit has dual 10/100Base-Tx ports which are connected to the CPU via a managed switch. The ports support auto MDI-X, auto negotiation, half & full duplex operation and flow control. These parameters can be configured in the network section of CCMS.

8.2.5.2 Asynchronous Serial (RS232)

The Tornado RS232 pin out is as per the EIA/TIA – 561 standards. Note: this is different to older Mimomax products.

Signal Name	Pin number	Direction
Tx Data	6	In to radio
Rx Data	5	Out of radio
CTS	7	Out of Radio
RTS	8	In to Radio
Ground	4	n/a
5VDC	1	Out of Radio

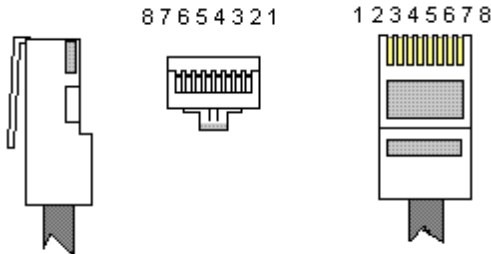

8.2.5.3 GPIO/Alarm/REF

The GPIO alarm and reference in/out signals are available via a 12-pin connector on the front of the tornado (see GPIO Connector below). A complete cable loom is available from Mimomax, or alternatively the female connector required is a JST HRP-12-S. For pinouts see Table 4: GPIO pin out.

Configuration of the GPIO should be performed using CCMS. See System > User GPIO for more information.

- The alarm provides both open and closed in alarm contacts and is isolated from the rest of the radio circuitry.
- The External reference input/output is an isolated differential pair.

GPIO as analog input:

- The GPIO signals are all referenced to the Radio ground. Their linear range is 0-12V, but they will survive up to 60V. An external series resistor can be used to provide a higher linear range using the following formula.

$$R_{ext} = (V_{max} - 12) * 109k / 12$$

- Where V_{max} is the maximum voltage that will be measured, $109k$ is the input impedance, and R_{ext} is an external series resistor between the voltage being measured and the tornado GPIO pin. Remember to round the resistor value up to the nearest resistor value above the calculated value.
- Next use the GPIO input calibration process to calibrate the system through the external resistor. This process will be based on a known voltage before the resistor.

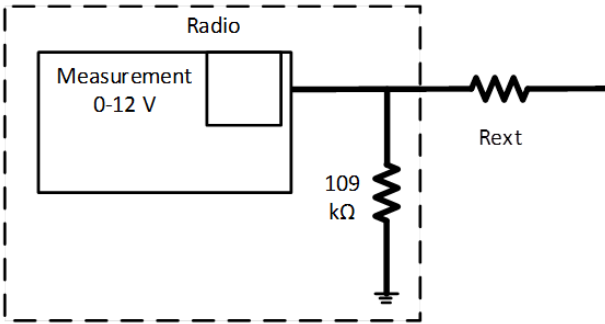

GPIO Input Circuit

GPIO as digital output:

- The GPIO pins provide an open collector output, which can be used to drive a relay or generate a level. The current can be up to 100 mA.

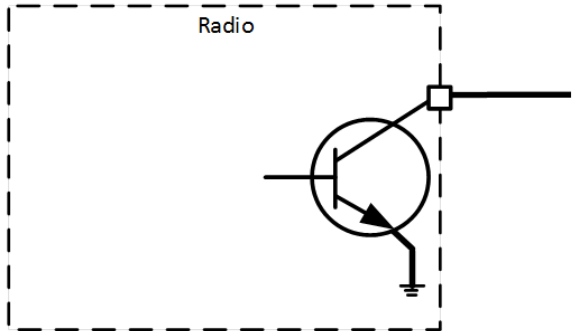

GPIO Output Circuit

Signal Name	Pin number	Colour on Mimomax cable
Not Connected	1	n/a
Ext Ref n	2	Brown
Ext Ref p	3	Red
GPIO Ground (Radio Ground)	4	Orange
GPIO_4	5	Yellow
GPIO_3	6	Green
GPIO_2	7	Blue
GPIO_1	8	Violet
Open in Alarm	9	Grey
Alarm Comm	10	White
Closed in Alarm	11	Black
Not Connected	12	n/a

Table 4: GPIO pin out

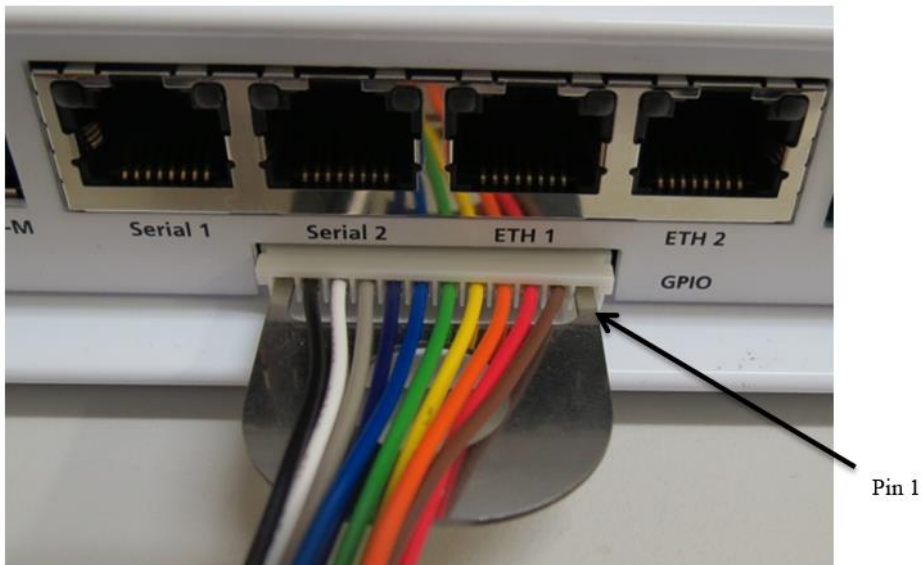

GPIO Connector

8.2.6 RF SPECIFICATION

General

Configuration	2x2 MIMO	
Connector type	N-Type, 50 Ohms	
Ambient Temperature Range	-30°C to +60°C Horizontal mount, all products or -30°C +70 °C for a vertically mounted RRU	
Base Gross Data Rate (One direction) (QPSK)	75 kHz	240 kbps Full-duplex
	50 kHz	160 kbps Full-duplex
	25 kHz	80kbps Full-duplex
	12.5kHz	40kbps Full-duplex
Upgradable Gross Data Rate (One direction) (16/64/256 QAM)	75 kHz	480/720/960 kbps Full-duplex
	50 kHz	320/480/640 kbps Full-duplex
	25 kHz	160/240/320kbps Full-duplex
	12.5kHz	80/120/160kbps Full-duplex

Receiver

Modulation	QPSK/16/64/256QAM	
Number of MIMO Receivers	2	
Symbol Rate	75 kHz	2x60k symbols/sec

	50 kHz	2x40k symbols/sec	
	25 kHz	2x20k symbols/sec	
	12.5	2x10k	symbols/sec
Modulation sensitivity ¹ for 10 ⁻⁴ BER	75kHz	-109/-102/-96/89 dBm (900MHz)	
	50 kHz	-111/-104/-98/-91 dBm (400, 700, and 900 MHz) -111/-104/-97/-92 dBm (VHF)	
	25 kHz	-114/-107/-101/-94dBm (400, 700, and 900 MHz) -114/-107/-101/-95 dBm (VHF)	
	12.5kHz	-117/-110/-104/-97dBm (400, 700 and 900 MHz) -117/-109/-103/-97 dBm (VHF)	
Modulation sensitivity ¹ for 10 ⁻⁷ BER	75kHz	-107/-100/-94/-87 dBm (900MHz)	
	50 kHz	-109/-102/-96/-89 dBm (400, 700, and 900 MHz) -109/-102/-95/-90 dBm (VHF)	
	25 kHz	-112/-105/-99/-92dBm (400, 700 and 900 MHz) -112/-105/-99/-93dBm (VHF)	
	12.5kHz	-116/-108/-102/-96dBm (400, 700 and 900 MHz) -115/-107/-101/-95dBm (VHF)	
Frequency Range	400 to 470 MHz, 757 to 758 and 787 to 788 MHz, 806 to 960 MHz, 136 to 174 MHz		
Frequency Step Size	5kHz & 6.25 kHz selectable		
Nominal Channel Bandwidth	12.5kHz, 25 kHz , 50kHz and 75kHz		
Maximum Signal Level	-10dBm/QPSK		
Absolute Maximum Input Level	+20dBm		

Transmitter

Number of MIMO Transmitters	2		
Nominal load impedance	50 Ohms		
	Require better than 1.5:1 VSWR (-14 dB return loss)		
Modulation	QPSK/16/64/256QAM		
Symbol Rate	75kHz	2x60 k symbols/s	
	50 kHz	2x40 k symbols/s	
	25 kHz	2x20 k symbols/s	
	12.5kHz	2x10 k symbols/s	
RF Power Output	2 x +24 dBm average +/-1.5 dBm, (+2/-3 at Extreme Temp.)		

RF Power Control Range	>20 dB
RF Power Control Resolution	0.5 dB
Frequency Range	400 to 470 MHz, 757 to 758 and 787 to 788 MHz, 806 to 960 MHz, 136 to 174 MHz
Frequency Accuracy and Stability	Better than +/-1 ppm

Transmitter (continued)

Adjacent Channel Power Ratio (ACPR)	>60 dB
Transient ACPR	>60 dB
Intermodulation Rejection	>70 dB
Tx Occupied BW	50 kHz 40 kHz
	25 kHz 20 kHz
	12.5 kHz 10 kHz

Internal Duplexer

Type	Bandpass
Tx/Rx Split	5MHz minimum (400 MHz), 30 MHz (700 MHz), 9 MHz minimum (900 MHz)
Frequency Range	400-430MHz, 420-450MHz, 440-470MHz
Stop Band Attenuation	>60dB @ >5MHz from centre (400 MHz), >75 dB (700 MHz), >60 dB @ >9Mhz from centre (900 MHz)
Pass Band Bandwidth	2MHz (-0.5dB) (400 MHz), 3 MHz (-0.5 dB) (700MHz), 4 MHz (-0.5 dB) (900 MHz)

1. Sensitivity as specified includes forward error correction and internal duplexer loss. Note that systems employing adaptive modulation (e.g MDL or MCAM) will automatically reduce the modulation order at a signal level higher than the specified sensitivity level. This will maintain the lowest possible error rate.

Table 5: RF characteristics

8.2.6.1 Site Engineering

For personal safety and equipment reliability reasons the following must be adhered to:

Power supply

The equipment must be powered from a power supply complying with the requirements of IEC 60950-1 including compliance with sub clause 7.4 'Insulation between primary circuits and cable distribution systems'.

Grounding

On site ground networks must be created in accordance with ITU-T Recommendation K.27: Protection against Interference; Bonding Configuration and Earthing inside a telecommunications building.

Equipment location

It is recommended that the radio unit is installed in a dry, dust-free room. If this is not possible then the waterproof boot must be fitted to protect the unit.

Equipment ventilation

A thermal study should be carried out for each site to check and ensure that thermal conditions within the enclosures do not go beyond the radio units operating limit. If the temperature of the site is known to exceed the operating limits of the unit, then the enclosure must have an air conditioning, or a forced air system installed to stabilise these excursions.

Lightning protection

Lightning protection is important to ensure the protection of the tower, antenna and the radio equipment hardware. Below shows the point earthing concept recommended.

The technique recommended to protect the radio unit, antenna, feeder and tower uses earthing kits in strategic places. The key points are: adjacent to the feeder connector at the antenna, where the feeder leaves the base of the tower and where the feeder enters the building structure. If earthing kits supplies are limited or connection to an earth point is difficult, then order of importance of the earthing locations is as follows:

(a) For a top mounted antenna acting for lightning protection:

1. At antenna connection point.
2. At the tower base.
3. At the entry to the building.

(b) For a general mounting of antenna:

1. At the entry to the building.
2. At the tower base.
3. At the antenna connector.

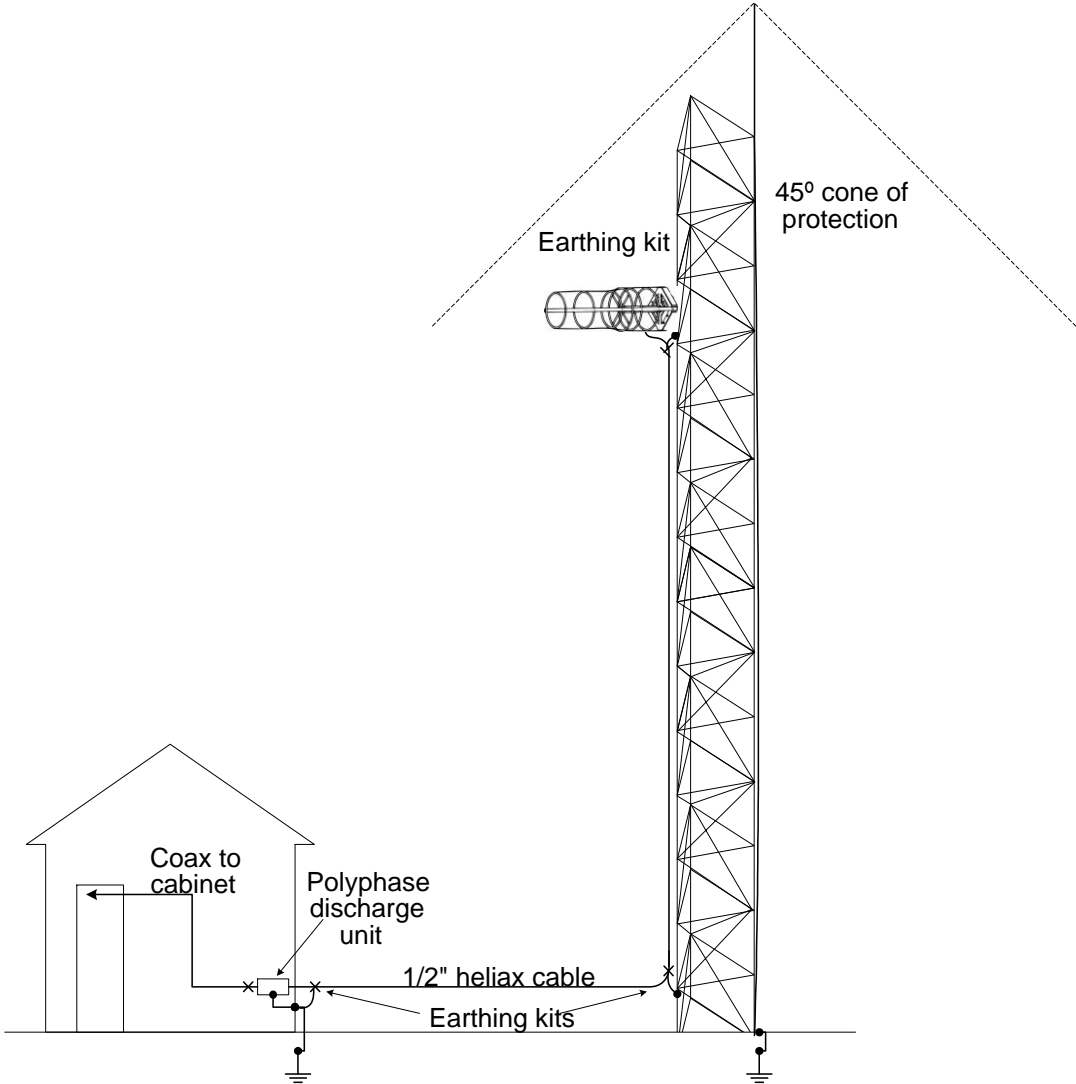

Lightning protection

A gas discharge unit is required to release high voltage charges developed between the cable inner and outer. There are two types available, a transmitting and a receiving variant. The transmitting variant is the larger. It is very important that these variants are not confused because the lower discharge potential rating for the receiver unit will be triggered by transmitting voltages. This will cause a high VSWR and poor performance.

8.3 INSTALLATION

Three styles of system installation are shown below. Of these, (a) has the lowest RF losses and the highest efficiency of power supply to the RU. However, mounting of the battery equipment up the pole may be considered a disadvantage from a mechanical or installation viewpoint. In (b), the RF losses are still low, but the DC power losses are highest, whilst in (c) the DC losses are minimised, and access is convenient but at the expense of RF performance. Option (b) may also be achieved using Power over Ethernet (PoE) which is described further in section 8.2.3.9.

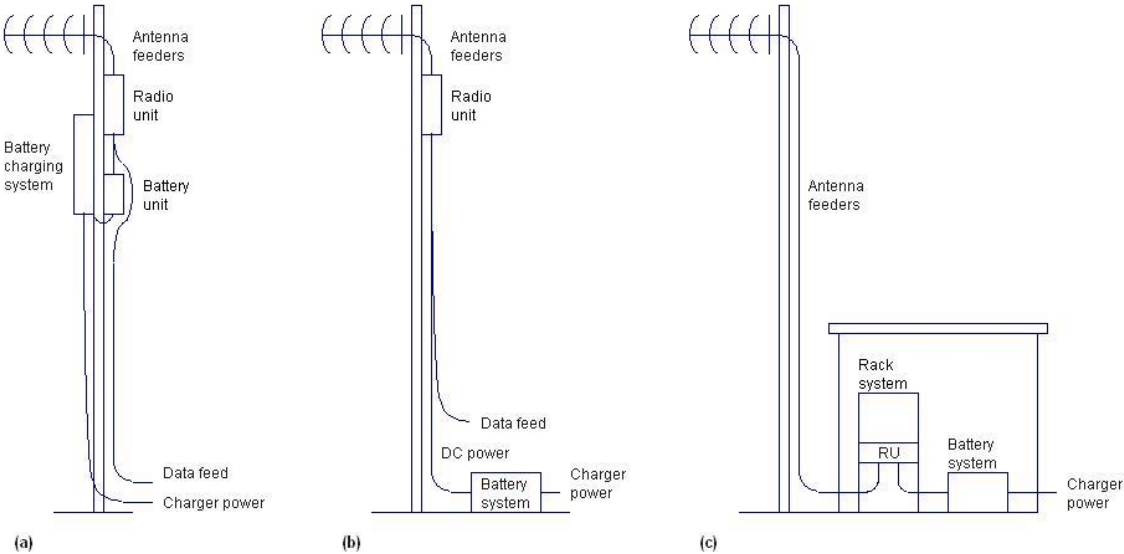

Typical pole and rack mounting options for the radio unit

Note: refer to section 8.2.6.1 for grounding and lightning protection considerations.

Regardless of the mounting configuration used, the appropriate site engineering must be undertaken. Site engineering must consider safety aspects such as grounding and lightning protection but also needs to take performance parameters such as antenna location, antenna separation and other RF sources. Please contact Mimomax if more information in these areas is required.

A comprehensive source of information and guidance on general site engineering issues has been published by ETSI: EG 200 053 v1.5.1, 2004/06 'Electromagnetic compatibility and Radio spectrum Matters (ERM); Radio site engineering for radio equipment and systems'. It is highly recommended that this freely available ETSI document be studied in detail, in conjunction with this manual.

8.4 COMPLIANCES

RF Bands	400-470MHz
Radio Performance	ACMA Spectrum Impact
	FCC 47CFR part 90
	IC Canada
	ETSI EN 302-561
EMC	AS/NZS/CISPR22
	EN301 489
	FCC 47CFR part 15
Safety	IEC 60950-1:2005, Am 1:2009, EN 62368-1:2014

RF Bands	757-758 & 787-788 MHz
Radio Performance	FCC 47CFR part 27
EMC	FCC 47CFR part 15
Environmental	60950-22 Outdoor Safety
Safety	IEC 60950-1:2005, Am 1:2009, EN 62368-1:2014

RF Bands	806 to 960 MHz
Radio Performance	FCC 47CFR part 90 (806 – 869MHz)
	FCC 47CFR part 101 (928 – 960MHz)
	IC Canada (RSS-119)
EMC	FCC47CFR part 15
Safety	IEC 60950-1:2005, Am 1:2009, EN 62368-1:2014

Table 6: Compliances

9 DOCUMENT HISTORY

Issue #	Date	Description
8	20/11/18	Added uncertainty of RSSI calibration figure to RSSI Calibration section
9	20/04/20	Added 400 MHz - 50 KHz capability. Licenses updated. RSSI process range changed from -50 and -90 to -40 and -60.
10	14/07/20	Updated number of supported RRUs.
11	15/05/21	FCC statement updates (Section 2.0). Latency table update (section 1.3)