

FCC Radio Test Report

FCC ID: XMF-MID7018

Original Grant

Report No. : TB-FCC178076
Applicant : Lightcomm Technology Co., Ltd.
Equipment Under Test (EUT)
EUT Name : onn 7" Tablet
Model No. : 100026191
Series Model No. : MID7018
Brand Name : onn
Sample ID : 20201103-05-1-01#& 20201103-05-1-04#
Receipt Date : 2020-11-05
Test Date : 2020-11-06 to 2020-12-28
Issue Date : 2020-12-29
Standards : FCC Part 15, Subpart E 15.407
Test Method : ANSI C63.10: 2013
Conclusions : **PASS**

In the configuration tested, the EUT complied with the standards specified above,

The EUT technically complies with the FCC and IC requirements

Test/Witness Engineer : *Rebecca*
Test/Witness Engineer : *IVAN SU*
Approved & Authorized : *Ray Lai*



This report details the results of the testing carried out on one sample. The results contained in this test report do not relate to other samples of the same product. The manufacturer should ensure that all products in series production are in conformity with the product sample detailed in the report.

Contents

CONTENTS.....	2
1. GENERAL INFORMATION ABOUT EUT	5
1.1 Client Information.....	5
1.2 General Description of EUT (Equipment Under Test)	5
1.3 Block Diagram Showing the Configuration of System Tested.....	7
1.4 Description of Support Units	7
1.5 Description of Test Mode.....	8
1.6 Description of Test Software Setting	10
1.7 Measurement Uncertainty	12
1.8 Test Facility.....	12
2. TEST SUMMARY	13
3. TEST SOFTWARE.....	13
4. TEST EQUIPMENT.....	14
5. CONDUCTED EMISSION TEST	15
5.1 Test Standard and Limit.....	15
5.2 Test Setup.....	15
5.3 Test Procedure.....	16
5.4 Deviation From Test Standard.....	16
5.5 EUT Operating Mode	16
5.6 Test Data.....	16
6. RADIATED EMISSION TEST	17
6.1 Test Standard and Limit.....	17
6.2 Test Setup.....	18
6.3 Test Procedure.....	19
6.4 Deviation From Test Standard.....	20
6.5 EUT Operating Condition	20
6.6 Test Data.....	20
7. BAND EDGE EMISSIONS	21
7.1 Test Standard and Limit.....	21
7.2 Test Setup.....	21
7.3 Test Procedure.....	22
7.4 Deviation From Test Standard.....	22
7.5 EUT Operating Condition	22
7.6 Test Data.....	22
8. BANDWIDTH TEST.....	23
8.1 Test Standard and Limit.....	23
8.2 Test Setup.....	23
8.3 Test Procedure.....	23

8.4 Deviation From Test Standard.....	24
8.5 EUT Operating Condition	24
8.6 Test Data.....	24
9. OUTPUT POWER TEST.....	25
9.1 Test Standard and Limit.....	25
9.2 Test Setup.....	25
9.3 Test Procedure.....	25
9.4 Deviation From Test Standard.....	25
9.5 EUT Operating Condition	25
9.6 Test Date.....	25
10. POWER SPECTRAL DENSITY TEST	26
10.1 Test Standard and Limit	26
10.2 Test Setup.....	26
10.3 Test Procedure.....	26
10.4 Deviation From Test Standard.....	27
10.5 EUT Operating Condition	27
10.6 Test Data.....	27
11. FREQUENCY STABILITY MEASUREMENT	28
11.1 Test Standard and Limit	28
11.2 Test Setup.....	28
11.3 Test Procedure.....	28
11.4 Deviation From Test Standard.....	28
11.5 EUT Operating Condition	29
11.6 Test Data.....	29
12. ANTENNA REQUIREMENT.....	30
12.1 Standard Requirement.....	30
12.2 Antenna Connected Construction.....	30
12.3 Deviation From Test Standard.....	30
12.4 Result.....	30
ATTACHMENT A-- CONDUCTED EMISSION TEST DATA	31
ATTACHMENT B-- RADIATED EMISSION TEST DATA	33
ATTACHMENT C-- RESTRICTED BANDS REQUIREMENT AND BAND-EDGE TEST DATA	95
ATTACHMENT D--BANDWIDTH TEST DATA.....	185
ATTACHMENT E--AVG OUTPUT POWER TEST DATA	242
ATTACHMENT F-- POWER SPECTRAL DENSITY TEST DATA.....	260
ATTACHMENT G----FREQUENCY STABILITY MEASUREMENT DATA.....	301

1. General Information about EUT

1.1 Client Information

Applicant	:	Lightcomm Technology Co., Ltd.
Address	:	UNIT 1306 13/F ARION COMMERCIAL CENTRE,2-12 QUEEN'S ROAD WEST, SHEUNG WAN HK
Manufacturer	:	Huizhou Hengdu Electronics Co., Ltd
Address	:	No.8 Huitai Road, Huinan High-tech Industrial Park, Huiiao Avenue, Huizhou, Guangdong, China.

1.2 General Description of EUT (Equipment Under Test)

EUT Name	:	onn 7" Tablet
Models No.	:	100026191, MID7018
Model Difference	:	All these models are identical in the same PCB, layout and electrical circuit, The only difference is model name.
Product Description	:	Operation Frequency: U-NII-1: 5180MHz~5240MHz, U-NII-2A: 5260MHz~5320MHz U-NII-2C: 5500MHz~5720MHz, U-NII-3: 5745MHz~5825MHz
	Antenna Gain:	0.42dBi FPC Antenna
	Modulation Type:	802.11a: OFDM (QPSK, BPSK, 16QAM) 802.11n: OFDM (QPSK, BPSK, 16QAM, 64QAM) 802.11ac: OFDM (QPSK, BPSK, 16QAM, 64QAM, 256QAM)
	Bit Rate of Transmitter:	802.11a: 6/9/12/18/24/36/48/54 Mbps 802.11n: up to 150Mbps 802.11ac: at most 433.3 Mbps
Power Rating	:	Adapter(TEKA-UCA10US) Input: 100-240V~, 50/60Hz, 0.2A MAX Output: DC 5V 1A DC 3.8V by 3700mAh Rechargeable Li-ion battery
Software Version	:	RP1A.200720.011 release-keys
Hardware Version	:	MID7018-MR_MT8168_LPDDR4_EMMC_V1_1
Remark	:	The adapter and antenna gain provided by the applicant, the verified for the RF conduction test provided by TOBY test lab.

Note:

(1) This Test Report is FCC Part 15, Subpart E(15.407) for 802.11a/n/ac, the test procedure follows the KDB 789033 D02 General U-NII Test Procedures New Rules v02r01. More detailed features description, please refer to the manufacturer's specifications or the User's Manual.

(2) Channel List:

Frequency Band	Channel No.	Frequency	Channel No.	Frequency
5180~5240MHz (U-NII-1)	36	5180 MHz	44	5220 MHz
	38	5190 MHz	46	5230 MHz
	40	5200 MHz	48	5240 MHz
	42	5210 MHz		

For 20 MHz Bandwidth, use channel 36, 40, 44, 48. For 40 MHz Bandwidth, use channel 38, 46.
For 80 MHz Bandwidth, use channel 42.

Frequency Band	Channel No.	Frequency	Channel No.	Frequency
5260~5320 MHz (U-NII-2A)	52	5260 MHz	60	5300 MHz
	54	5270 MHz	62	5310MHz
	56	5280MHz	64	5320 MHz
	58	5290MHz		

For 20 MHz Bandwidth, use channel 52, 56, 60, 64. For 40 MHz Bandwidth, use channel 54, 62.
For 80 MHz Bandwidth, use channel 58.

Frequency Band	Channel No.	Frequency	Channel No.	Frequency
5500~5720 MHz (U-NII-2C)	100	5500 MHz	124	5620 MHz
	102	5510 MHz	126	5630 MHz
	104	5520 MHz	128	5640 MHz
	106	5530 MHz	132	5660 MHz
	108	5540 MHz	134	5670 MHz
	110	5550 MHz	136	5680 MHz
	112	5560 MHz	138	5690 MHz
	116	5580 MHz	140	5700 MHz
	118	5590 MHz	142	5710 MHz
	120	5600 MHz	144	5720 MHz
	122	5610 MHz		

For 20 MHz Bandwidth, use channel 100, 104, 108, 112, 116, 120, 124, 128, 132, 136, 140, 144
For 40 MHz Bandwidth, use channel 102, 110, 118, 126, 134, 142
For 80 MHz Bandwidth, use channel 106, 122, 138.

Frequency Band	Channel No.	Frequency	Channel No.	Frequency
5745~5825MHz (U-NII-3)	149	5745 MHz	157	5785 MHz
	151	5755 MHz	159	5795 MHz
	153	5765 MHz	161	5805 MHz
	155	5775 MHz	165	5825 MHz

For 20 MHz Bandwidth, use channel 149, 153, 157, 161, 165. For 40 MHz Bandwidth, use channel 151, 159.
For 80 MHz Bandwidth, use channel 155.

1.3 Block Diagram Showing the Configuration of System Tested

Charging + TX Mode



TX Mode

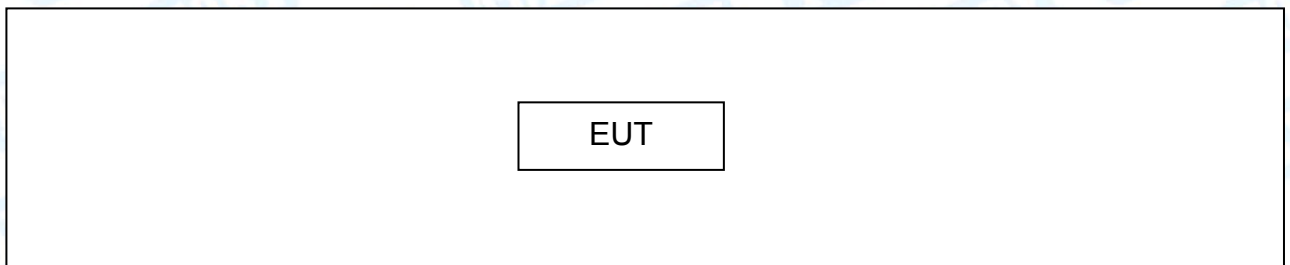

1.4 Description of Support Units

The EUT has been test as an independent unit.

1.5 Description of Test Mode

To investigate the maximum EMI emission characteristics generates from EUT, the test system was pre-scanning tested base on the consideration of following EUT operation mode or test configuration mode which possible have effect on EMI emission level. Each of these EUT operation mode(s) or test configuration mode(s) mentioned follow was evaluated respectively.

For Conducted Test		
Final Test Mode	Description	
Mode 1	Charging + TX a Mode(5180MHz)	
For Radiated Test Below 1GHz		
Final Test Mode	Description	
Mode 2	Charging + TX a Mode(5180MHz)	
For Radiated Test Above 1GHz		
Test Band	Final Test Mode	Description
U-NII-1	Mode 3	TX Mode 802.11a Mode Channel 36/40/48
	Mode 4	TX Mode 802.11n(HT20) Mode Channel 36/40/48
	Mode 5	TX Mode 802.11ac(VHT20) Mode Channel 36/40/48
	Mode 6	TX Mode 802.11n(HT40) Mode Channel 38/46
	Mode 7	TX Mode 802.11ac(VHT40) Mode Channel 38/46
	Mode 8	TX Mode 802.11ac(VHT80) Mode Channel 42
U-NII-2A	Mode 9	TX Mode 802.11a Mode Channel 52/56/64
	Mode 10	TX Mode 802.11n(HT20) Mode Channel 52/56/64
	Mode 11	TX Mode 802.11ac(VHT20) Mode Channel 52/56/64
	Mode 12	TX Mode 802.11n(HT40) Mode Channel 54/62
	Mode 13	TX Mode 802.11ac(VHT40) Mode Channel 54/62
	Mode 14	TX Mode 802.11ac(VHT80) Mode Channel 58
U-NII-2C	Mode 15	TX Mode 802.11a Mode Channel 100/120/144
	Mode 16	TX Mode 802.11n(HT20) Mode Channel 100/120/144
	Mode 17	TX Mode 802.11ac(VHT20) Mode Channel 100/120/144
	Mode 18	TX Mode 802.11n(HT40) Mode Channel 102/118/142
	Mode 19	TX Mode 802.11ac(VHT40) Mode Channel 102/118/142
	Mode 20	TX Mode 802.11ac(VHT80) Mode Channel 106/122/138
U-NII-3	Mode 21	TX Mode 802.11a Mode Channel 149/157/165
	Mode 22	TX Mode 802.11n(HT20) Mode Channel 149/157/165
	Mode 23	TX Mode 802.11ac(VHT20) Mode Channel 149/157/165
	Mode 24	TX Mode 802.11n(HT40) Mode Channel 151/159
	Mode 25	TX Mode 802.11ac(VHT40) Mode Channel 151/159
	Mode 26	TX Mode 802.11ac(VHT80) Mode Channel 155

Note:

(1) For all test, we have verified the construction and function in typical operation. And all the

test modes were carried out with the EUT in transmitting operation in maximum power with all kinds of data rate.

According to ANSI C63.10 standards, the measurements are performed at the highest, middle, lowest available channels, and the worst case data rate as follows:

- 802.11a Mode: OFDM (6 Mbps)
- 802.11n (HT20) Mode: MCS 0
- 802.11n (HT40) Mode: MCS 0
- 802.11ac(VHT20) Mode: MCS 0
- 802.11ac(VHT40) Mode: MCS 0
- 802.11ac(VHT80) Mode: MCS 0

- (2) During the testing procedure, the continuously transmitting with the maximum power mode was programmed by the customer.
- (3) The EUT is considered a portable unit; it was positioned on X-plane. The worst case was found positioned on X-plane. Therefore only the test data of this X-plane was used for radiated emission measurement test.

1.6 Description of Test Software Setting

During testing channel & Power controlling software provided by the customer was used to control the operating channel as well as the output power level. The RF output power selection is for the setting of RF output power expected by the customer and is going to be fixed on the firmware of the final end product power parameters of WLAN.

Test Software: MT8168-LaunchEngMode.apk		
Test Mode: Continuously transmitting		
U-NII-1		
Mode	Frequency (MHz)	Parameters
802.11a	5180	13
	5200	13
	5240	13
802.11n(HT20)	5180	12
	5200	12
	5240	12
802.11ac(VHT20)	5180	12
	5200	12
	5240	12
802.11n(HT40)	5190	12
	5230	12
802.11ac(VHT40)	5190	12
	5230	12
802.11ac(VHT80)	5210	12
U-NII-2A		
Mode	Frequency (MHz)	Parameters
802.11a	5260	13
	5280	13
	5320	13
802.11n(HT20)	5260	12
	5280	12
	5320	12
802.11ac(HT20)	5260	12
	5280	12
	5320	12
802.11n(HT40)	5270	12
	5310	12
802.11ac(VHT40)	5270	12
	5310	12
802.11ac(VHT80)	5290	12

U-NII-2C		
Mode	Frequency (MHz)	Parameters
802.11a	5500	13
	5600	13
	5720	13
802.11n(HT20)	5500	12
	5600	12
	5720	12
802.11ac(HT20)	5500	12
	5600	12
	5720	12
802.11n(HT40)	5510	12
	5590	12
	5710	12
802.11ac(VHT40)	5510	12
	5590	12
	5710	12
802.11ac(VHT80)	5530	12
	5610	12
	5690	12
U-NII-3		
Mode	Frequency (MHz)	Parameters
802.11a	5745	13
	5785	13
	5825	13
802.11n(HT20)	5745	12
	5785	12
	5825	12
802.11ac(HT20)	5745	12
	5785	12
	5825	12
802.11n(HT40)	5755	12
	5795	12
802.11ac(VHT40)	5755	12
	5795	12
802.11ac(VHT80)	5775	12

1.7 Measurement Uncertainty

The reported uncertainty of measurement $y \pm U$, where expanded uncertainty U is based on a standard uncertainty multiplied by a coverage factor of $k=2$, providing a level of confidence of approximately 95 %.

Test Item	Parameters	Expanded Uncertainty (U_{Lab})
Conducted Emission	Level Accuracy: 9kHz~150kHz 150kHz to 30MHz	± 3.50 dB ± 3.10 dB
Radiated Emission	Level Accuracy: 9kHz to 30 MHz	± 4.60 dB
Radiated Emission	Level Accuracy: 30MHz to 1000 MHz	± 4.50 dB
Radiated Emission	Level Accuracy: Above 1000MHz	± 4.20 dB

1.8 Test Facility

The testing was performed by the Shenzhen Toby Technology Co., Ltd., in their facilities located at: 1A/F., Bldg.6, Yusheng Industrial Zone, The National Road No.107 Xixiang Section 467, Xixiang, Bao'an, Shenzhen, Guangdong, China.

At the time of testing, the following bodies accredited the Laboratory:

CNAS (L5813)

The Laboratory has been accredited by CNAS to ISO/IEC 17025: 2017 General Requirements for the Competence of Testing and Calibration Laboratories for the competence in the field of testing. And the Registration No.: CNAS L5813.

A2LA Certificate No.: 4750.01

The laboratory has been accredited by American Association for Laboratory Accreditation(A2LA) to ISO/IEC 17025: 2017 General Requirements for the Competence of Testing and Calibration Laboratories for the technical competence in the field of Electrical Testing. And the A2LA Certificate No.: 4750.01.FCC Accredited Test Site Number: 854351.

IC Registration No.: (11950A)

The Laboratory has been registered by Certification and Engineering Bureau of Industry Canada for radio equipment testing. The site registration: Site# 11950A.

2. Test Summary

FCC Part 15 Subpart E(15.407)				
Standard Section	Test Item	Test Sample(s)	Judgment	Remark
FCC				
15.203	Antenna Requirement	20201103-05-1-01#	PASS	N/A
15.207	Conducted Emission	20201103-05-1-04#	PASS	N/A
15.407(b)	Band Edge Emissions	20201103-05-1-01#	PASS	N/A
15.407(a)	26dB Bandwidth&99% Bandwidth	20201103-05-1-01#	PASS	N/A
15.407(e)	6dB Bandwidth(only for UNII-3)	20201103-05-1-01#	PASS	N/A
15.407(a)	AVG Output Power	20201103-05-1-01#	PASS	N/A
15.407(a)	Power Spectral Density	20201103-05-1-01#	PASS	N/A
15.407(b)	Transmitter Radiated Spurious Emission	20201103-05-1-01# 20201103-05-1-04#	PASS	N/A
15.407(g)	Frequency Stability	20201103-05-1-01#	PASS	N/A

Note: “/” for no requirement for this test item.
 N/A is an abbreviation for Not Applicable.

3. Test Software

Test Item	Test Software	Manufacturer	Version No.
Conducted Emission	EZ-EMC	EZ	CDI-03A2
Radiation Emission	EZ-EMC	EZ	FA-03A2RE
RF Conducted Measurement	MTS-8310	MWRfTest	V2.0.0.0

4. Test Equipment

Conducted Emission Test					
Equipment	Manufacturer	Model No.	Serial No.	Last Cal.	Cal. Due Date
EMI Test Receiver	Rohde & Schwarz	ESCI	100321	Jul. 06, 2020	Jul. 05, 2021
RF Switching Unit	Compliance Direction Systems Inc	RSU-A4	34403	Jul. 06, 2020	Jul. 05, 2021
AMN	SCHWARZBECK	NNBL 8226-2	8226-2/164	Jul. 06, 2020	Jul. 05, 2021
LISN	Rohde & Schwarz	ENV216	101131	Jul. 06, 2020	Jul. 05, 2021
Radiation Emission Test					
Equipment	Manufacturer	Model No.	Serial No.	Last Cal.	Cal. Due Date
Spectrum Analyzer	Agilent	E4407B	MY45106456	Jul. 06, 2020	Jul. 05, 2021
EMI Test Receiver	Rohde & Schwarz	ESPI	100010/007	Jul. 06, 2020	Jul. 05, 2021
Spectrum Analyzer	Rohde & Schwarz	FSV40-N	102197	Jul. 06, 2020	Jul. 05, 2021
Bilog Antenna	ETS-LINDGREN	3142E	00117537	Mar.01, 2020	Feb. 28, 2022
Horn Antenna	ETS-LINDGREN	3117	00143207	Mar.01, 2020	Feb. 28, 2022
Horn Antenna	ETS-LINDGREN	BBHA 9170	BBHA9170582	Mar.01, 2020	Feb. 28, 2022
Loop Antenna	SCHWARZBECK	FMZB 1519 B	1519B-059	Jul. 07, 2020	Jul. 06, 2021
Pre-amplifier	Sonoma	310N	185903	Mar.01, 2020	Feb. 28, 2021
Pre-amplifier	HP	8449B	3008A00849	Mar.01, 2020	Feb. 28, 2021
Pre-amplifier	SKET	LNPA_1840G-50	SK201904032	Mar.01, 2020	Feb. 28, 2021
Cable	HUBER+SUHNER	100	SUCOFLEX	Mar.01, 2020	Feb. 28, 2021
Positioning Controller	ETS-LINDGREN	2090	N/A	N/A	N/A
Antenna Conducted Emission					
Equipment	Manufacturer	Model No.	Serial No.	Last Cal.	Cal. Due Date
Spectrum Analyzer	Agilent	E4407B	MY45106456	Jul. 06, 2020	Jul. 05, 2021
Spectrum Analyzer	Rohde & Schwarz	ESPI	100010/007	Jul. 06, 2020	Jul. 05, 2021
MXA Signal Analyzer	Agilent	N9020A	MY49100060	Sep. 11, 2020	Sep. 10, 2021
Vector Signal Generator	Agilent	N5182A	MY50141294	Sep. 11, 2020	Sep. 10, 2021
Analog Signal Generator	Agilent	N5181A	MY50141953	Sep. 11, 2020	Sep. 10, 2021
RF Power Sensor	DARE!! Instruments	RadiPowerRPR3006W	17100015SNO26	Sep. 11, 2020	Sep. 10, 2021
	DARE!! Instruments	RadiPowerRPR3006W	17100015SNO29	Sep. 11, 2020	Sep. 10, 2021
	DARE!! Instruments	RadiPowerRPR3006W	17100015SNO31	Sep. 11, 2020	Sep. 10, 2021
	DARE!! Instruments	RadiPowerRPR3006W	17100015SNO33	Sep. 11, 2020	Sep. 10, 2021

5. Conducted Emission Test

5.1 Test Standard and Limit

5.1.1 Test Standard

FCC Part 15.207

5.1.2 Test Limit

Conducted Emission Test Limit

Frequency	Maximum RF Line Voltage (dB μ V)	
	Quasi-peak Level	Average Level
150kHz~500kHz	66 ~ 56 *	56 ~ 46 *
500kHz~5MHz	56	46
5MHz~30MHz	60	50

Notes:

(1) *Decreasing linearly with logarithm of the frequency.

(2) The lower limit shall apply at the transition frequencies.

(3) The limit decrease in line with the logarithm of the frequency in the range of 0.15 to 0.50MHz.

5.2 Test Setup

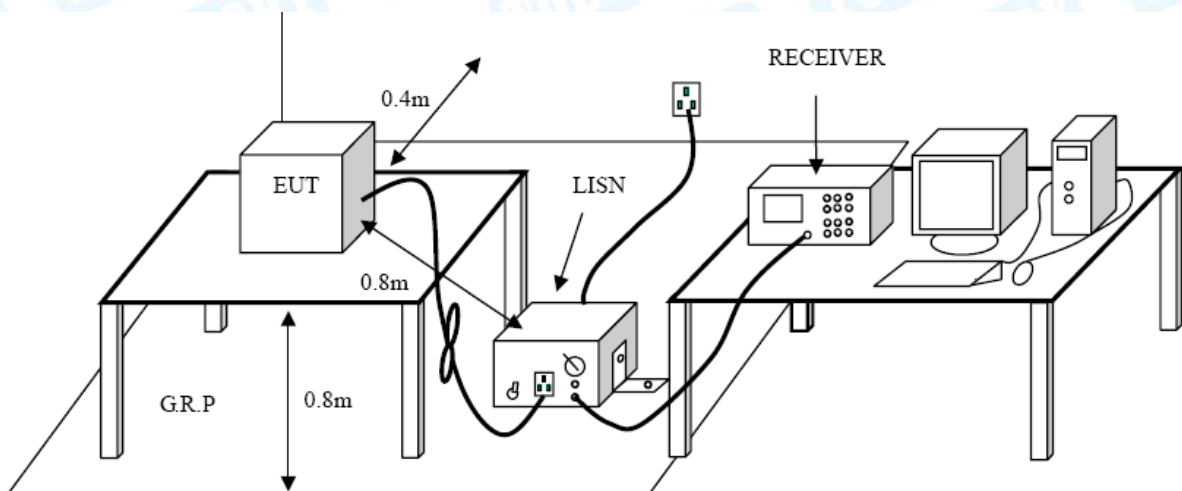

5.3 Test Procedure

The EUT was placed 0.8 meters from the horizontal ground plane with EUT being connected to the power mains through a line impedance stabilization network (LISN). All other support equipments powered from additional LISN(s). The LISN provide 50 Ohm/50uH of coupling impedance for the measuring instrument.

Interconnecting cables that hang closer than 40 cm to the ground plane shall be folded back and forth in the center forming a bundle 30 to 40 cm long.

I/O cables that are not connected to a peripheral shall be bundled in the center. The end of the cable may be terminated, if required, using the correct terminating impedance. The overall length shall not exceed 1 m.

LISN at least 80 cm from nearest part of EUT chassis.

The bandwidth of EMI test receiver is set at 9kHz, and the test frequency band is from 0.15MHz to 30MHz.

5.4 Deviation From Test Standard

No deviation

5.5 EUT Operating Mode

Please refer to the description of test mode.

5.6 Test Data

Please refer to the Attachment A.

6. Radiated Emission Test

6.1 Test Standard and Limit

- 6.1.1 Test Standard
FCC Part 15.209
- 6.1.2 Test Limit

Radiated Emission Limits (9kHz~1000MHz)

Frequency (MHz)	Field Strength (microvolt/meter)	Measurement Distance (meters)
0.009~0.490	2400/F(KHz)	300
0.490~1.705	24000/F(KHz)	30
1.705~30.0	30	30
30~88	100	3
88~216	150	3
216~960	200	3
Above 960	500	3

Radiated Emission Limit (Above 1000MHz)

Frequency (MHz)	Distance of 3m (dBuV/m)	
	Peak	Average
Above 1000	74	54

Note:

- (1) The tighter limit applies at the band edges.
- (2) Emission Level(dBuV/m)=20log Emission Level(uV/m)

Limits of unwanted emission out of the restricted bands

Frequency (MHz)	EIRP Limits (dBm)	Equivalent Field Strength at 3m (dBuV/m)
5150~5250	-27	68.3
5250~5350	-27	68.3
5470~5725	-27	68.3
5725~5825	-27(Note 2)	68.3
	10(Note 2)	105.3
	15.6(Note 2)	110.9
	27(Note 2)	122.3

NOTE:

1, The following formula is used to convert the equipment isotropic radiated power (eirp) to field strength:

$$E = \frac{1000000\sqrt{30P}}{3} \text{ uV/m, where P is the eirp (Watts)}$$

2, According to FCC 16-24, All emissions shall be limited to a level of -27 dBm/MHz at 75 MHz or more above or below the band edge increasing linearly to 10 dBm/MHz at 25 MHz above or below the band edge, and from 25MHz above or below the band edge increasing linearly to a level of 15.6 dBm/MHz at 5 MHz above or below the band edge, and from 5 MHz above or below the band edge increasing linearly to a level of 27dBm/MHz at the band edge.

6.2 Test Setup

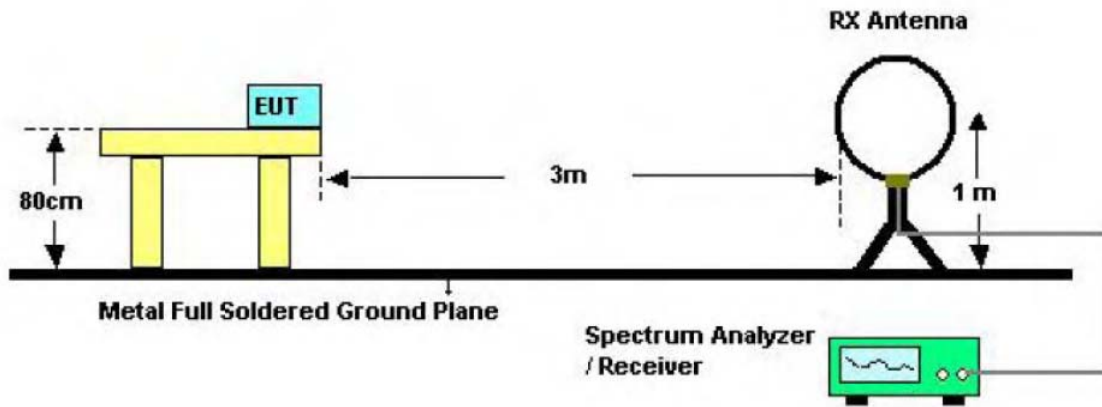

Below 30MHz Test Setup

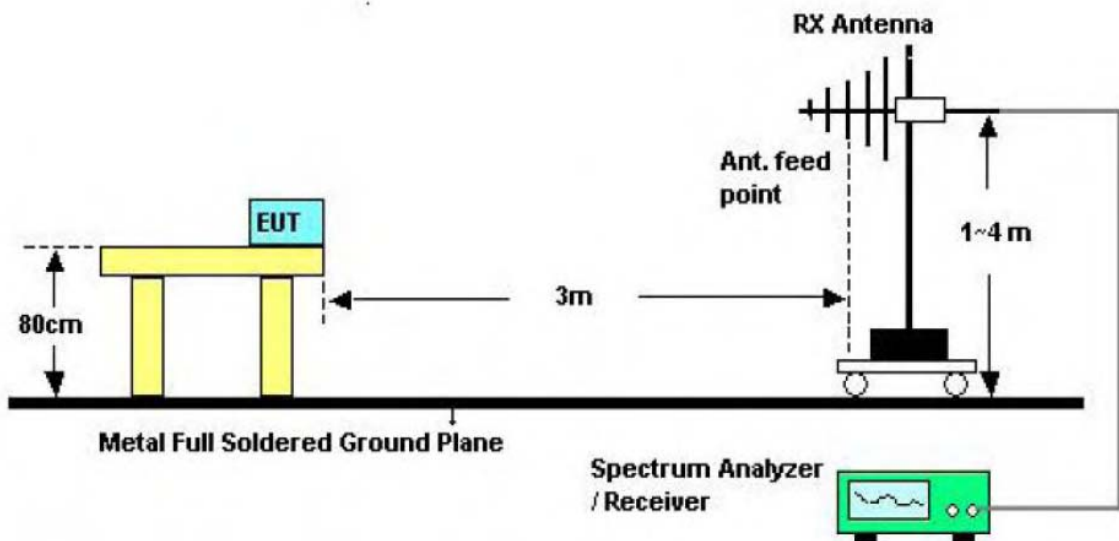

Below 1000MHz Test Setup

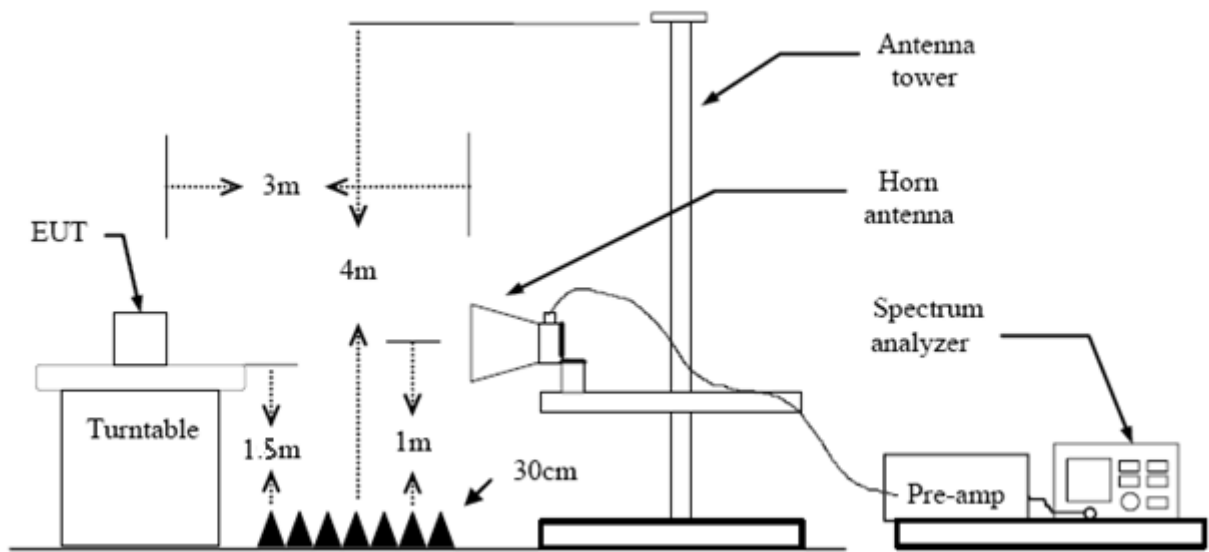

Above 1GHz Test Setup

6.3 Test Procedure

- (1) The measuring distance of 3m shall be used for measurements at frequency up to 1GHz. The EUT was placed on a rotating 0.8m high above the ground, the table was rotated 360 degrees to determine the position of the highest radiation.
- (2) Measurements at frequency above 1GHz. The EUT was placed on a rotating 1.5m high above the ground. RF absorbers covered the ground plane with a minimum area of 3.0m by 3.0m between the EUT and measurement receiver antenna. The RF absorber shall not exceed 30cm in high above the conducting floor. The table was rotated 360 degrees to determine the position of the highest radiation.
- (3) The Test antenna shall vary between 1m and 4m, Both Horizontal and Vertical Antenna Ore set to make measurement.
- (4) The initial step in collecting conducted emission data is a spectrum analyzer peak detector mode pre-scanning the measurement frequency range. Significant peaks are then marked and then Quasi Peak detector mode re-measured.
- (5) If the Peak Mode measured value compliance with and lower than Quasi Peak Mode Limit Bellow 1 GHz, the EUT shall be deemed to meet QP Limits and then no additional QP Mode measurement performed. But the Peak Value and average value both need to comply with applicable limit above 1 GHz.
- (6) Testing frequency range below 1GHz the measuring instrument use VBW=120 kHz with Quasi-peak detection.
- (7) Testing frequency range above 1GHz the measuring instrument use RBW=1 MHz and VBW=3 MHz with Peak Detector for Peak Values, and use RBW=1 MHz and VBW=10 Hz with Peak Detector for Average Values.
- (8) For the actual test configuration, please see the test setup photo.

6.4 Deviation From Test Standard

No deviation

6.5 EUT Operating Condition

The Equipment Under Test was set to Continual Transmitting in maximum power.

6.6 Test Data

Remark: During testing above 1GHz the measuring instrument use RBW=1 MHz and VBW=3 MHz with Peak Detector for Peak Values, and use RBW=1 MHz and VBW=10 Hz with Peak Detector for Average Values.

Please refer to the Attachment B.

7. Band Edge Emissions

7.1 Test Standard and Limit

7.1.1 Test Standard

FCC Part 15.407(b)

7.1.2 Test Limit

Limits of unwanted emission out of the restricted bands

Frequency (MHz)	EIRP Limits (dBm)	Equivalent Field Strength at 3m (dBuV/m)
5150~5250	-27	68.3
5250~5350	-27	68.3
5470~5725	-27	68.3
5725~5825	-27(Note 2)	68.3
	10(Note 2)	105.3
	15.6(Note 2)	110.9
	27(Note 2)	122.3

NOTE:

1, The following formula is used to convert the equipment isotropic radiated power (eirp) to field strength:

$$E = \frac{1000000\sqrt{30P}}{3} \text{ uV/m, where P is the eirp (Watts)}$$

2, According to FCC 16-24, All emissions shall be limited to a level of -27 dBm/MHz at 75 MHz or more above or below the band edge increasing linearly to 10 dBm/MHz at 25 MHz above or below the band edge, and from 25MHz above or below the band edge increasing linearly to a level of 15.6 dBm/MHz at 5 MHz above or below the band edge, and from 5 MHz above or below the band edge increasing linearly to a level of 27dBm/MHz at the band edge.

7.2 Test Setup

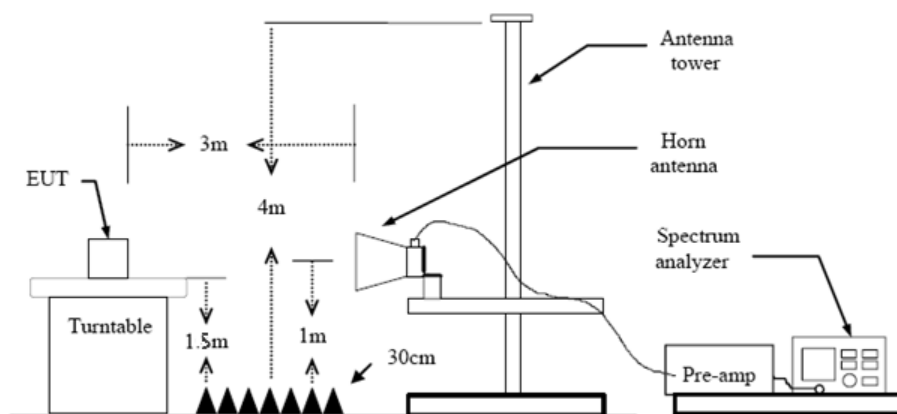

7.3 Test Procedure

- (1) The measuring distance of 3m shall be used for measurements at frequency up to 1GHz. The EUT was placed on a rotating 0.8m high above the ground, the table was rotated 360 degrees to determine the position of the highest radiation.
- (2) Measurements at frequency above 1GHz. The EUT was placed on a rotating 1.5m high above the ground. RF absorbers covered the ground plane with a minimum area of 3.0m by 3.0m between the EUT and measurement receiver antenna. The RF absorber shall not exceed 30cm in high above the conducting floor. The table was rotated 360 degrees to determine the position of the highest radiation.
- (3) The Test antenna shall vary between 1m and 4m, Both Horizontal and Vertical Antenna Ore set to make measurement.
- (4) The initial step in collecting conducted emission data is a spectrum analyzer peak detector mode pre-scanning the measurement frequency range. Significant peaks are then marked and then Quasi Peak detector mode re-measured.
- (5) If the Peak Mode measured value compliance with and lower than Quasi Peak Mode Limit Bellow 1 GHz, the EUT shall be deemed to meet QP Limits and then no additional QP Mode measurement performed. But the Peak Value and average value both need to comply with applicable limit above 1 GHz.
- (6) Testing frequency range below 1GHz the measuring instrument use VBW=120 kHz with Quasi-peak detection.
- (7) Testing frequency range above 1GHz the measuring instrument use RBW=1 MHz and VBW=3 MHz with Peak Detector for Peak Values, and use RBW=1 MHz and VBW=10 Hz with Peak Detector for Average Values.
- (8) For the actual test configuration, please see the test setup photo.

7.4 Deviation From Test Standard

No deviation

7.5 EUT Operating Condition

The Equipment Under Test was set to Continual Transmitting in maximum power.

7.6 Test Data

Please refer to the Attachment C.

8. Bandwidth Test

8.1 Test Standard and Limit

- 8.1.1 Test Standard
FCC Part 15.407
- 8.1.2 Test Limit

FCC Part 15 Subpart C(15.407)/RSS-210		
Test Item	Limit	Frequency Range (MHz)
26 Bandwidth	N/A	5150~5250
		5250~5350
		5500~5700
6 dB Bandwidth	>500kHz	5725~5850

8.2 Test Setup

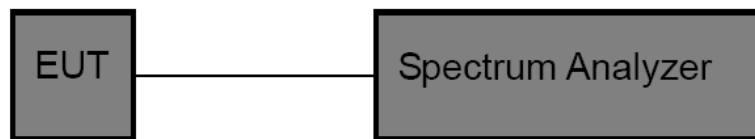

8.3 Test Procedure

- (1) The EUT was directly connected to the spectrum analyzer and antenna output port as show in the block diagram above.
- (2) The setting of the spectrum analyser as below:

26dB Bandwidth Test	
Spectrum Parameters	Setting
Attenuation	Auto
Span	>26 dB Bandwidth
RBW	Approximately 1% of the emission bandwidth
VBW	VBW>RBW
Detector	Peak
Trace	Max Hold
Sweep Time	Auto

6dB Bandwidth Test	
Spectrum Parameters	Setting
Attenuation	Auto
Span	>6 dB Bandwidth
RBW	100 kHz
VBW	VBW>=3*RBW
Detector	Peak
Trace	Max Hold
Sweep Time	Auto
99% Occupied Bandwidth Test	
Spectrum Parameters	Setting
Attenuation	Auto
RBW	1% to 5% of the OBW
VBW	≥ 3RBW
Detector	Peak
Trace	Max Hold

8.4 Deviation From Test Standard

No deviation

8.5 EUT Operating Condition

The EUT was set to continuously transmitting in each mode and low, Middle and high channel for the test.

8.6 Test Data

Please refer to the Attachment D.

9. Output Power Test

9.1 Test Standard and Limit

9.1.1 Test Standard

FCC Part 15.407 (a)

9.1.2 Test Limit

FCC Part 15 Subpart E(15.407)/RSS-210		
Test Item	Limit	Frequency Range(MHz)
Conducted Output Power	Fixed: 1 Watt (30dBm) Mobile and Portable: 250mW (24dBm)	5150~5250
	250mW (24dBm)	5250~5350
	250mW (24dBm)	5500~5700
	1 Watt (30dBm)	5725~5850

9.2 Test Setup

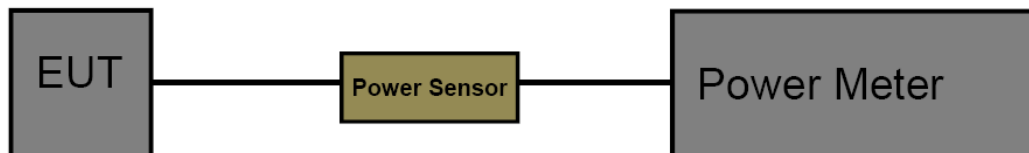

9.3 Test Procedure

The measurement is according to section 3 of KDB 789033 D02 General U-NII Test Procedures New Rules v02r01.

The EUT was connected to RF power meter via a broadband power sensor as show the block above.

9.4 Deviation From Test Standard

No deviation

9.5 EUT Operating Condition

The EUT was set to continuously transmitting in the max power during the test.

9.6 Test Date

Please refer to the Attachment E.

10. Power Spectral Density Test

10.1 Test Standard and Limit

10.1.1 Test Standard

FCC Part 15.407 (a)

10.1.2 Test Limit

FCC Part 15 Subpart E(15.407)		
Test Item	Limit	Frequency Range(MHz)
Power Spectral Density	Other than Mobile and Portable : 17dBm/MHz Mobile and Portable : 11dBm/MHz	5150~5250
	11dBm/MHz	5250~5350
	11dBm/MHz	5500~5700
	30dBm/500kHz	5725~5850

9.2 Test Setup

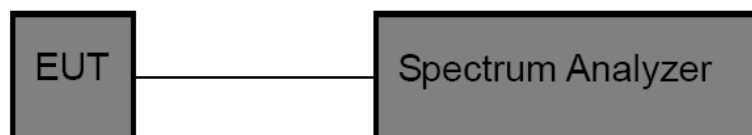

10.3 Test Procedure

The EUT was directly connected to the Spectrum Analyzer and antenna output port as show in the block diagram above. The measurement is according to KDB 789033 D02 General U-NII Test Procedures New Rules v02r01.

- (1) The EUT was directly connected to the spectrum analyzer and antenna output port as show in the block diagram above.
- (2) Set analyser centre frequency to transmitting frequency.
- (3) Set the span to encompass the entire emissions bandwidth (EBW)(alternatively, the entire 99% OBW) of the signal.
- (4) Set the RBW to: 1 MHz
- (5) Set the VBW to: 3 MHz
- (6) Detector: RMS
- (7) Trace: Max Hold
- (7) Sweep time: auto
- (8) Trace average at least 100 traces in power averaging.
- (9) User the peak marker function to determine the maximum amplitude level within the RBW.
Apply correction to the result if different RBW is used.

10.4 Deviation From Test Standard

No deviation

10.5 EUT Operating Condition

The EUT was set to continuously transmitting in each mode and low, Middle and high channel for the test.

10.6 Test Data

Please refer to the Attachment F.

11. Frequency Stability Measurement

11.1 Test Standard and Limit

- 11.1.1 Test Standard
FCC Part 15.407
- 11.1.2 Test Limit

FCC Part 15 Subpart C(15.407)		
Test Item	Limit	Frequency Range(MHz)
Peak Excursion Measurement	Manufacturers of U-NII devices are responsible for ensuring frequency stability such that an emission is maintained within the band of operation under all conditions of normal operation as specified in the users manual	5150~5250
		5250~5350
		5500~5700
		5725~5850

11.2 Test Setup

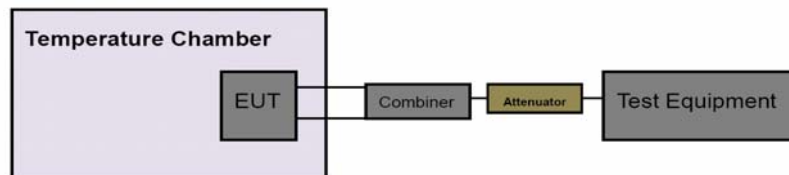

11.3 Test Procedure

The EUT was directly connected to the Spectrum Analyzer and antenna output port as show in the block diagram above.

- (1) The EUT was directly connected to the spectrum analyzer and antenna output port as show in the block diagram above.
- (2) Set analyser centre frequency to transmitting frequency.
- (3) Set the span to encompass the entire emissions bandwidth (EBW) of the signal.
- (4) Set the RBW to: 10 kHz, VBW=10 kHz with peak detector and maxhold settings.
- (5) The test extreme voltage is to change the primary supply voltage from 85 to 115 percent of the nominal value.
- (6) Extreme temperature is 0°C~50°C

11.4 Deviation From Test Standard

No deviation

11.5 EUT Operating Condition

The EUT was set to continuously transmitting in continuously un-modulation transmitting mode.

11.6 Test Data

Please refer to the Attachment G.

12. Antenna Requirement

12.1 Standard Requirement

12.1.1 Standard

FCC Part 15.203

12.1.2 Requirement

An intentional radiator shall be designed to ensure that no antenna other than that furnished by the responsible party shall be used with the device. The use of a permanently attached antenna or of an antenna that uses a unique coupling to the intentional radiator shall be considered sufficient to comply with the provisions of this Section. The manufacturer may design the unit so that a broken antenna can be replaced by the user, but the use of a standard antenna jack or electrical connector is prohibited.

12.2 Antenna Connected Construction

The gains of the antenna used for transmitting is 0.42 dBi, and the antenna de-signed with permanent attachment and no consideration of replacement. Please see the EUT photo for details.

12.3 Deviation From Test Standard

No deviation

12.4 Result

The EUT antennas are FPC Antenna. It complies with the standard requirement.

Antenna Type
<input type="checkbox"/> Permanent attached antenna
<input checked="" type="checkbox"/> Unique connector antenna
<input type="checkbox"/> Professional installation antenna

Attachment A-- Conducted Emission Test Data

Remark: All channels have been tested and Shows only the worst channels.

Temperature:	24.8 °C	Relative Humidity:	42%
Test Voltage:	AC 120V/60 Hz		
Terminal:	Line		
Test Mode:	TX 802.11a Mode CH36		
Remark:	Only worse case is reported.		

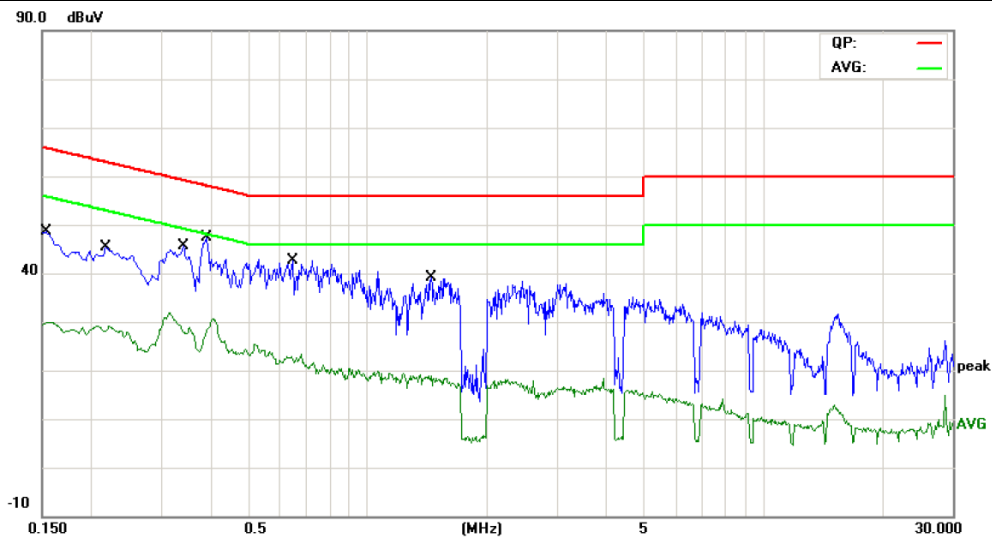

No.	Mk.	Freq. MHz	Reading Level dBμV	Correct Factor dB	Measure- ment dBμV	Limit dBμV	Over dB	Detector
1		0.1539	30.94	9.70	40.64	65.78	-25.14	QP
2		0.1539	17.48	9.70	27.18	55.78	-28.60	AVG
3		0.2180	30.15	9.70	39.85	62.89	-23.04	QP
4		0.2180	17.72	9.70	27.42	52.89	-25.47	AVG
5		0.3420	28.85	9.70	38.55	59.15	-20.60	QP
6		0.3420	12.90	9.70	22.60	49.15	-26.55	AVG
7	*	0.3899	29.91	9.70	39.61	58.06	-18.45	QP
8		0.3899	17.95	9.70	27.65	48.06	-20.41	AVG
9		0.6460	24.14	9.70	33.84	56.00	-22.16	QP
10		0.6460	12.59	9.70	22.29	46.00	-23.71	AVG
11		1.4460	21.64	9.76	31.40	56.00	-24.60	QP
12		1.4460	6.68	9.76	16.44	46.00	-29.56	AVG

*:Maximum data x:Over limit !:over margin

Remark:

1. Corr. = Antenna Factor (dB/m) + Cable Loss (dB)
2. QuasiPeak (dBμV/m)= Corr. (dB/m)+ Read Level (dBμV)
3. Margin (dB) = QuasiPeak (dBμV/m)-Limit QPK(dBμV/m)

Temperature:	24.8 °C	Relative Humidity:	42%
Test Voltage:	AC 120V/60 Hz		
Terminal:	Neutral		
Test Mode:	TX 802.11a Mode CH36		
Remark:	Only worse case is reported		

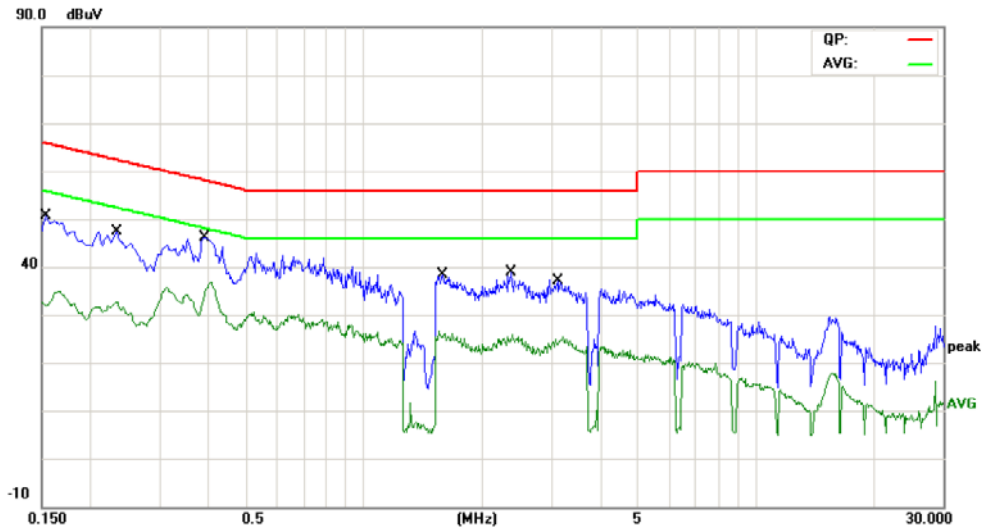

No.	Mk.	Freq. MHz	Reading Level dBuV	Correct Factor dB	Measure- ment dBuV	Limit dBuV	Over dB	Detector
1		0.1539	33.00	9.80	42.80	65.78	-22.98	QP
2		0.1539	21.06	9.80	30.86	55.78	-24.92	AVG
3		0.2340	29.86	9.80	39.66	62.30	-22.64	QP
4		0.2340	20.70	9.80	30.50	52.30	-21.80	AVG
5	*	0.3899	32.80	9.80	42.60	58.06	-15.46	QP
6		0.3899	18.38	9.80	28.18	48.06	-19.88	AVG
7		1.5900	23.17	9.80	32.97	56.00	-23.03	QP
8		1.5900	15.28	9.80	25.08	46.00	-20.92	AVG
9		2.3820	22.53	9.80	32.33	56.00	-23.67	QP
10		2.3820	14.57	9.80	24.37	46.00	-21.63	AVG
11		3.1140	21.14	9.80	30.94	56.00	-25.06	QP
12		3.1140	8.25	9.80	18.05	46.00	-27.95	AVG

*:Maximum data x:Over limit !:over margin

Remark:

1. Corr. = Antenna Factor (dB/m) + Cable Loss (dB)
2. QuasiPeak (dBµV/m)= Corr. (dB/m)+ Read Level (dBµV)
3. Margin (dB) = QuasiPeak (dBµV/m)-Limit QPK(dBµV/m)

Attachment B-- Radiated Emission Test Data

9 KHz~30 MHz

From 9 KHz to 30 MHz: Conclusion: PASS

Note: The amplitude of spurious emissions which are attenuated by more than 20dB below the permissible value has no need to be reported.

30MHz~1GHz

Temperature:	24.6 °C	Relative Humidity:	43%
Test Voltage:	AC 120V/60Hz		
Ant. Pol.	Horizontal		
Test Mode:	TX 802.11a Mode 5180MHz (U-NII-1)		
Remark:	Only worse case is reported		

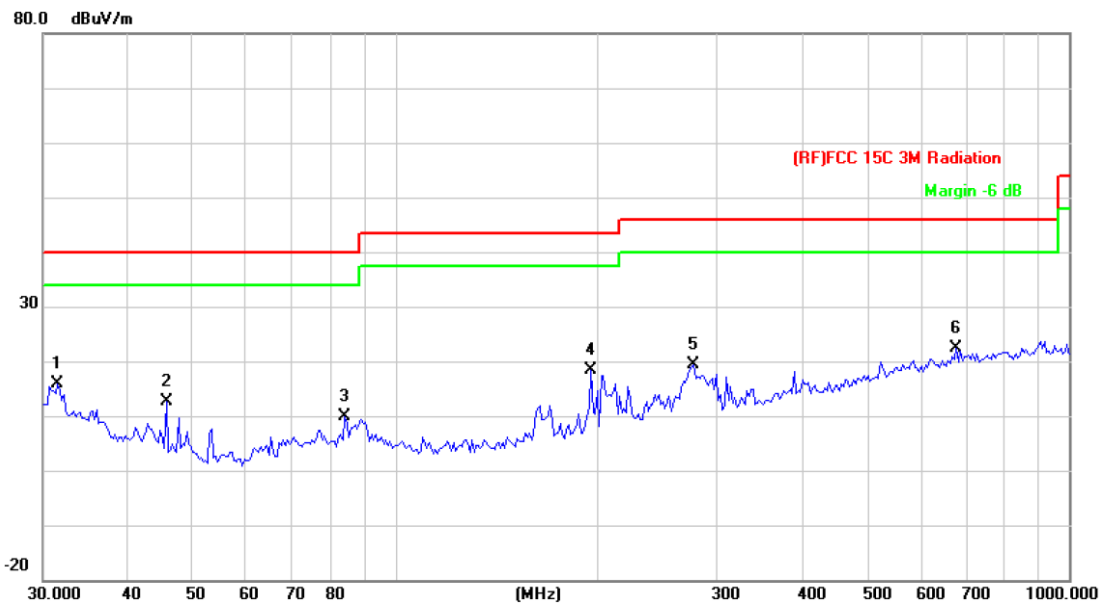

No.	Mk.	Freq. MHz	Reading Level dBuV	Correct Factor dB/m	Measure- ment dBuV/m	Limit dBuV/m	Over dB	Detector
1		31.5094	29.86	-14.08	15.78	40.00	-24.22	peak
2		45.6948	34.21	-21.65	12.56	40.00	-27.44	peak
3		84.1099	32.16	-22.21	9.95	40.00	-30.05	peak
4		195.1365	38.19	-19.87	18.32	43.50	-25.18	peak
5		277.0935	35.98	-16.72	19.26	46.00	-26.74	peak
6	*	679.9600	29.68	-7.25	22.43	46.00	-23.57	peak

*:Maximum data x:Over limit !:over margin

Remark:

1. Corr. = Antenna Factor (dB/m) + Cable Loss (dB)
2. QuasiPeak (dBμV/m)= Corr. (dB/m)+ Read Level (dBμV)
3. Margin (dB) = QuasiPeak (dBμV/m)-Limit QPK(dBμV/m)

Temperature:	24.6 °C	Relative Humidity:	43%
Test Voltage:	AC 120V/60Hz		
Ant. Pol.	Vertical		
Test Mode:	TX 802.11a Mode 5180MHz (U-NII-1)		
Remark:	Only worse case is reported.		

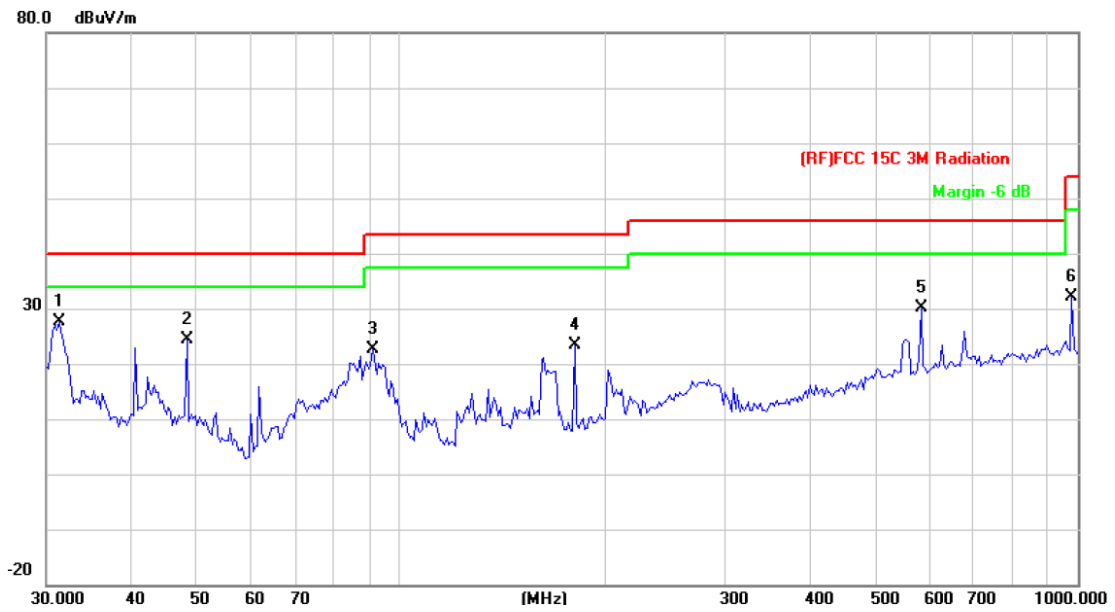

No.	Mk.	Freq. MHz	Reading Level dBuV	Correct Factor dB/m	Measure- ment dBuV/m	Limit dBuV/m	Over dB	Detector
1	*	31.2893	41.60	-13.91	27.69	40.00	-12.31	peak
2		48.3318	47.00	-22.50	24.50	40.00	-15.50	peak
3		90.8554	44.49	-21.87	22.62	43.50	-20.88	peak
4		180.6487	43.37	-20.10	23.27	43.50	-20.23	peak
5		586.8437	38.61	-8.47	30.14	46.00	-15.86	peak
6		979.1803	36.16	-4.05	32.11	54.00	-21.89	peak

*:Maximum data x:Over limit !:over margin

Remark:

1. Corr. = Antenna Factor (dB/m) + Cable Loss (dB)
2. QuasiPeak (dBμV/m)= Corr. (dB/m)+ Read Level (dBμV)
3. Margin (dB) = QuasiPeak (dBμV/m)-Limit QPK(dBμV/m)

5180MHz-5240MHz(U-NII-1)

Temperature:	25 °C	Relative Humidity:	55%
Test Voltage:	DC 3.8V		
Ant. Pol.	Horizontal		
Test Mode:	TX 802.11a Mode 5180MHz (U-NII-1)		
Remark:	No report for the emission which more than 20 dB below the prescribed limit. Only worse case is reported.		

No.	Mk.	Freq.	Reading Level	Correct Factor	Measurement	Limit	Over	Detector
		MHz	dBuV	dB/m	dBuV/m	dBuV/m	dB	
1		10360.352	27.27	18.05	45.32	54.00	-8.68	AVG
2	*	10360.367	43.80	18.05	61.85	68.30	-6.45	peak

Remark:
 1. Corr. = Antenna Factor (dB/m) + Cable Loss (dB)
 2. Peak/AVG (dBμV/m)= Corr. (dB/m)+ Read Level (dBμV)
 3. Margin (dB) = Peak/AVG (dBμV/m)-Limit PK/AVG(dBμV/m)

Temperature:	25 °C	Relative Humidity:	55%
Test Voltage:	DC 3.8V		
Ant. Pol.	Vertical		
Test Mode:	TX 802.11a Mode 5180MHz (U-NII-1)		
Remark:	No report for the emission which more than 20 dB below the prescribed limit. Only worse case is reported.		

No.	Mk.	Freq.	Reading Level	Correct Factor	Measurement	Limit	Over	Detector
		MHz	dBuV	dB/m	dBuV/m	dBuV/m	dB	
1	*	10359.612	29.30	18.05	47.35	54.00	-6.65	AVG
2		10359.677	41.16	18.05	59.21	68.30	-9.09	peak

Remark:
 1. Corr. = Antenna Factor (dB/m) + Cable Loss (dB)
 2. Peak/AVG (dBμV/m)= Corr. (dB/m)+ Read Level (dBμV)
 3. Margin (dB) = Peak/AVG (dBμV/m)-Limit PK/AVG(dBμV/m)

Temperature:	25 °C	Relative Humidity:	55%
Test Voltage:	DC 3.8V		
Ant. Pol.	Horizontal		
Test Mode:	TX 802.11a Mode 5200MHz (U-NII-1)		
Remark:	No report for the emission which more than 20 dB below the prescribed limit.		

No.	Mk.	Freq.	Reading Level	Correct Factor	Measurement	Limit	Over	Detector
		MHz	dBuV	dB/m	dBuV/m	dBuV/m	dB	
1		10400.315	40.11	18.14	58.25	68.30	-10.05	peak
2	*	10400.324	28.37	18.14	46.51	54.00	-7.49	AVG

Remark:

1. Corr. = Antenna Factor (dB/m) + Cable Loss (dB)
2. Peak/AVG (dBμV/m)= Corr. (dB/m)+ Read Level (dBμV)
3. Margin (dB) = Peak/AVG (dBμV/m)-Limit PK/AVG(dBμV/m)

Temperature:	25 °C	Relative Humidity:	55%
Test Voltage:	DC 3.8V		
Ant. Pol.	Vertical		
Test Mode:	TX 802.11a Mode 5200MHz (U-NII-1)		
Remark:	No report for the emission which more than 20 dB below the prescribed limit.		

No.	Mk.	Freq.	Reading Level	Correct Factor	Measurement	Limit	Over	Detector
		MHz	dBuV	dB/m	dBuV/m	dBuV/m	dB	
1		10399.584	27.09	18.14	45.23	54.00	-8.77	AVG
2	*	10399.935	43.33	18.14	61.47	68.30	-6.83	peak

Remark:

1. Corr. = Antenna Factor (dB/m) + Cable Loss (dB)
2. Peak/AVG (dBμV/m)= Corr. (dB/m)+ Read Level (dBμV)
3. Margin (dB) = Peak/AVG (dBμV/m)-Limit PK/AVG(dBμV/m)

Temperature:	25 °C	Relative Humidity:	55%
Test Voltage:	DC 3.8V		
Ant. Pol.	Horizontal		
Test Mode:	TX 802.11a Mode 5240MHz (U-NII-1)		
Remark:	No report for the emission which more than 20 dB below the prescribed limit.		

No.	Mk.	Freq.	Reading Level	Correct Factor	Measurement	Limit	Over	Detector
		MHz	dBuV	dB/m	dBuV/m	dBuV/m	dB	
1		10480.245	28.01	18.31	46.32	54.00	-7.68	AVG
2	*	10480.360	43.53	18.31	61.84	68.30	-6.46	peak

Remark:

1. Corr. = Antenna Factor (dB/m) + Cable Loss (dB)
2. Peak/AVG (dBμV/m)= Corr. (dB/m)+ Read Level (dBμV)
3. Margin (dB) = Peak/AVG (dBμV/m)-Limit PK/AVG(dBμV/m)

Temperature:	25 °C	Relative Humidity:	55%
Test Voltage:	DC 3.8V		
Ant. Pol.	Vertical		
Test Mode:	TX 802.11a Mode 5240MHz (U-NII-1)		
Remark:	No report for the emission which more than 20 dB below the prescribed limit.		

No.	Mk.	Freq.	Reading Level	Correct Factor	Measurement	Limit	Over	Detector
		MHz	dBuV	dB/m	dBuV/m	dBuV/m	dB	
1	*	10479.615	27.02	18.31	45.33	54.00	-8.67	AVG
2		10479.664	40.37	18.31	58.68	68.30	-9.62	peak

Remark:

1. Corr. = Antenna Factor (dB/m) + Cable Loss (dB)
2. Peak/AVG (dBμV/m)= Corr. (dB/m)+ Read Level (dBμV)
3. Margin (dB) = Peak/AVG (dBμV/m)-Limit PK/AVG(dBμV/m)

Temperature:	25 °C	Relative Humidity:	55%
Test Voltage:	DC 3.8V		
Ant. Pol.	Horizontal		
Test Mode:	TX 802.11n(HT20) Mode 5180MHz (U-NII-1)		
Remark:	No report for the emission which more than 20 dB below the prescribed limit.		

No.	Mk.	Freq.	Reading Level	Correct Factor	Measurement	Limit	Over	Detector
		MHz	dBuV	dB/m	dBuV/m	dBuV/m	dB	
1	*	10359.841	27.16	18.05	45.21	54.00	-8.79	AVG
2		10359.860	40.75	18.05	58.80	68.30	-9.50	peak

Remark:
 1. Corr. = Antenna Factor (dB/m) + Cable Loss (dB)
 2. Peak/AVG (dBμV/m)= Corr. (dB/m)+ Read Level (dBμV)
 3. Margin (dB) = Peak/AVG (dBμV/m)-Limit PK/AVG(dBμV/m)

Temperature:	25 °C	Relative Humidity:	55%
Test Voltage:	DC 3.8V		
Ant. Pol.	Vertical		
Test Mode:	TX 802.11n(HT20) Mode 5180MHz (U-NII-1)		
Remark:	No report for the emission which more than 20 dB below the prescribed limit.		

No.	Mk.	Freq.	Reading Level	Correct Factor	Measurement	Limit	Over	Detector
		MHz	dBuV	dB/m	dBuV/m	dBuV/m	dB	
1		10360.354	26.19	18.05	44.24	54.00	-9.76	AVG
2	*	10360.371	43.41	18.05	61.46	68.30	-6.84	peak

Remark:
 1. Corr. = Antenna Factor (dB/m) + Cable Loss (dB)
 2. Peak/AVG (dBμV/m)= Corr. (dB/m)+ Read Level (dBμV)
 3. Margin (dB) = Peak/AVG (dBμV/m)-Limit PK/AVG(dBμV/m)

Temperature:	25 °C	Relative Humidity:	55%
Test Voltage:	DC 3.8V		
Ant. Pol.	Horizontal		
Test Mode:	TX 802.11n(HT20) Mode 5200MHz (U-NII-1)		
Remark:	No report for the emission which more than 20 dB below the prescribed limit.		

No.	Mk.	Freq. MHz	Reading Level dBuV	Correct Factor dB/m	Measure- ment dBuV/m	Limit dBuV/m	Over dB	Detector
1		10400.354	27.07	18.14	45.21	54.00	-8.79	AVG
2	*	10400.411	43.26	18.14	61.40	68.30	-6.90	peak

Remark:
 1. Corr. = Antenna Factor (dB/m) + Cable Loss (dB)
 2. Peak/AVG (dBµV/m)= Corr. (dB/m)+ Read Level (dBµV)
 3. Margin (dB) = Peak/AVG (dBµV/m)-Limit PK/AVG(dBµV/m)

Temperature:	25 °C	Relative Humidity:	55%
Test Voltage:	DC 3.8V		
Ant. Pol.	Vertical		
Test Mode:	TX 802.11n(HT20) Mode 5200MHz (U-NII-1)		
Remark:	No report for the emission which more than 20 dB below the prescribed limit.		

No.	Mk.	Freq. MHz	Reading Level dBuV	Correct Factor dB/m	Measure- ment dBuV/m	Limit dBuV/m	Over dB	Detector
1	*	10400.122	28.19	18.14	46.33	54.00	-7.67	AVG
2		10400.178	40.05	18.14	58.19	68.30	-10.11	peak

Remark:
 1. Corr. = Antenna Factor (dB/m) + Cable Loss (dB)
 2. Peak/AVG (dBµV/m)= Corr. (dB/m)+ Read Level (dBµV)
 3. Margin (dB) = Peak/AVG (dBµV/m)-Limit PK/AVG(dBµV/m)

Temperature:	25 °C	Relative Humidity:	55%
Test Voltage:	DC 3.8V		
Ant. Pol.	Horizontal		
Test Mode:	TX 802.11n(HT20) Mode 5240MHz (U-NII-1)		
Remark:	No report for the emission which more than 20 dB below the prescribed limit.		

No.	Mk.	Freq.	Reading Level	Correct Factor	Measurement	Limit	Over	Detector
		MHz	dBuV	dB/m	dBuV/m	dBuV/m	dB	
1	*	10479.624	27.01	18.31	45.32	54.00	-8.68	AVG
2		10479.664	39.99	18.31	58.30	68.30	-10.00	peak

Remark:

1. Corr. = Antenna Factor (dB/m) + Cable Loss (dB)
2. Peak/AVG (dBuV/m)= Corr. (dB/m)+ Read Level (dBuV)
3. Margin (dB) = Peak/AVG (dBuV/m)-Limit PK/AVG(dBuV/m)

Temperature:	25 °C	Relative Humidity:	55%
Test Voltage:	DC 3.8V		
Ant. Pol.	Vertical		
Test Mode:	TX 802.11n(HT20) Mode 5240MHz (U-NII-1)		
Remark:	No report for the emission which more than 20 dB below the prescribed limit.		

No.	Mk.	Freq.	Reading Level	Correct Factor	Measurement	Limit	Over	Detector
		MHz	dBuV	dB/m	dBuV/m	dBuV/m	dB	
1	*	10479.911	44.29	18.31	62.60	68.30	-5.70	peak
2		10479.924	24.90	18.31	43.21	54.00	-10.79	AVG

Remark:

1. Corr. = Antenna Factor (dB/m) + Cable Loss (dB)
2. Peak/AVG (dBuV/m)= Corr. (dB/m)+ Read Level (dBuV)
3. Margin (dB) = Peak/AVG (dBuV/m)-Limit PK/AVG(dBuV/m)

Temperature:	25 °C	Relative Humidity:	55%
Test Voltage:	DC 3.8V		
Ant. Pol.	Horizontal		
Test Mode:	TX 802.11ac(VHT20) Mode 5180MHz (U-NII-1)		
Remark:	No report for the emission which more than 20 dB below the prescribed limit.		

No.	Mk.	Freq.	Reading Level	Correct Factor	Measurement	Limit	Over	Detector
		MHz	dBuV	dB/m	dBuV/m	dBuV/m	dB	
1	*	10359.886	43.61	18.05	61.66	68.30	-6.64	peak
2		10359.886	27.28	18.05	45.33	54.00	-8.67	AVG

Remark:

1. Corr. = Antenna Factor (dB/m) + Cable Loss (dB)
2. Peak/AVG (dBµV/m)= Corr. (dB/m)+ Read Level (dBµV)
3. Margin (dB) = Peak/AVG (dBµV/m)-Limit PK/AVG(dBµV/m)

Temperature:	25 °C	Relative Humidity:	55%
Test Voltage:	DC 3.8V		
Ant. Pol.	Vertical		
Test Mode:	TX 802.11ac(VHT20) Mode 5180MHz (U-NII-1)		
Remark:	No report for the emission which more than 20 dB below the prescribed limit.		

No.	Mk.	Freq.	Reading Level	Correct Factor	Measurement	Limit	Over	Detector
		MHz	dBuV	dB/m	dBuV/m	dBuV/m	dB	
1		10359.780	41.16	18.05	59.21	68.30	-9.09	peak
2	*	10359.780	27.31	18.05	45.36	54.00	-8.64	AVG

Remark:

1. Corr. = Antenna Factor (dB/m) + Cable Loss (dB)
2. Peak/AVG (dBµV/m)= Corr. (dB/m)+ Read Level (dBµV)
3. Margin (dB) = Peak/AVG (dBµV/m)-Limit PK/AVG(dBµV/m)

Temperature:	25 °C	Relative Humidity:	55%
Test Voltage:	DC 3.8V		
Ant. Pol.	Horizontal		
Test Mode:	TX 802.11ac(VHT20) Mode 5200MHz (U-NII-1)		
Remark:	No report for the emission which more than 20 dB below the prescribed limit.		

No.	Mk.	Freq.	Reading Level	Correct Factor	Measurement	Limit	Over	Detector
		MHz	dBuV	dB/m	dBuV/m	dBuV/m	dB	
1	*	10400.013	40.61	18.14	58.75	68.30	-9.55	peak
2		10400.013	24.23	18.14	42.37	54.00	-11.63	AVG

Remark:
1. Corr. = Antenna Factor (dB/m) + Cable Loss (dB)
2. Peak/AVG (dBμV/m)= Corr. (dB/m)+ Read Level (dBμV)
3. Margin (dB) = Peak/AVG (dBμV/m)-Limit PK/AVG(dBμV/m)

Temperature:	25 °C	Relative Humidity:	55%
Test Voltage:	DC 3.8V		
Ant. Pol.	Vertical		
Test Mode:	TX 802.11ac(VHT20) Mode 5200MHz (U-NII-1)		
Remark:	No report for the emission which more than 20 dB below the prescribed limit.		

No.	Mk.	Freq.	Reading Level	Correct Factor	Measurement	Limit	Over	Detector
		MHz	dBuV	dB/m	dBuV/m	dBuV/m	dB	
1	*	10400.361	43.88	18.14	62.02	68.30	-6.28	peak
2		10400.361	28.26	18.14	46.40	54.00	-7.60	AVG

Remark:
1. Corr. = Antenna Factor (dB/m) + Cable Loss (dB)
2. Peak/AVG (dBμV/m)= Corr. (dB/m)+ Read Level (dBμV)
3. Margin (dB) = Peak/AVG (dBμV/m)-Limit PK/AVG(dBμV/m)

Temperature:	25 °C	Relative Humidity:	55%
Test Voltage:	DC 3.8V		
Ant. Pol.	Horizontal		
Test Mode:	TX 802.11 ac(VHT20) Mode 5240MHz (U-NII-1)		
Remark:	No report for the emission which more than 20 dB below the prescribed limit.		

No.	Mk.	Freq.	Reading Level	Correct Factor	Measurement	Limit	Over	Detector
		MHz	dBuV	dB/m	dBuV/m	dBuV/m	dB	
1	*	10479.899	43.26	18.31	61.57	68.30	-6.73	peak
2		10479.899	28.02	18.31	46.33	54.00	-7.67	AVG

Remark:
1. Corr. = Antenna Factor (dB/m) + Cable Loss (dB)
2. Peak/AVG (dBµV/m)= Corr. (dB/m)+ Read Level (dBµV)
3. Margin (dB) = Peak/AVG (dBµV/m)-Limit PK/AVG(dBµV/m)

Temperature:	25 °C	Relative Humidity:	55%
Test Voltage:	DC 3.8V		
Ant. Pol.	Vertical		
Test Mode:	TX 802.11ac(VHT20) Mode 5240MHz (U-NII-1)		
Remark:	No report for the emission which more than 20 dB below the prescribed limit.		

No.	Mk.	Freq.	Reading Level	Correct Factor	Measurement	Limit	Over	Detector
		MHz	dBuV	dB/m	dBuV/m	dBuV/m	dB	
1		10480.140	39.78	18.31	58.09	68.30	-10.21	peak
2	*	10480.140	26.81	18.31	45.12	54.00	-8.88	AVG

Remark:
1. Corr. = Antenna Factor (dB/m) + Cable Loss (dB)
2. Peak/AVG (dBµV/m)= Corr. (dB/m)+ Read Level (dBµV)
3. Margin (dB) = Peak/AVG (dBµV/m)-Limit PK/AVG(dBµV/m)

Temperature:	25 °C	Relative Humidity:	55%
Test Voltage:	DC 3.8V		
Ant. Pol.	Horizontal		
Test Mode:	TX 802.11n(HT40) Mode 5190MHz (U-NII-1)		
Remark:	No report for the emission which more than 20 dB below the prescribed limit.		

No.	Mk.	Freq.	Reading Level	Correct Factor	Measurement	Limit	Over	Detector
		MHz	dBuV	dB/m	dBuV/m	dBuV/m	dB	
1	*	10380.024	28.24	18.09	46.33	54.00	-7.67	AVG
2		10380.040	42.39	18.09	60.48	68.30	-7.82	peak

Remark:
 1. Corr. = Antenna Factor (dB/m) + Cable Loss (dB)
 2. Peak/AVG (dBμV/m)= Corr. (dB/m)+ Read Level (dBμV)
 3. Margin (dB) = Peak/AVG (dBμV/m)-Limit PK/AVG(dBμV/m)

Temperature:	25 °C	Relative Humidity:	55%
Test Voltage:	DC 3.8V		
Ant. Pol.	Vertical		
Test Mode:	TX 802.11n(HT40) Mode 5190MHz (U-NII-1)		
Remark:	No report for the emission which more than 20 dB below the prescribed limit.		

No.	Mk.	Freq.	Reading Level	Correct Factor	Measurement	Limit	Over	Detector
		MHz	dBuV	dB/m	dBuV/m	dBuV/m	dB	
1	*	10379.624	27.59	18.09	45.68	54.00	-8.32	AVG
2		10379.672	41.63	18.09	59.72	68.30	-8.58	peak

Remark:
 1. Corr. = Antenna Factor (dB/m) + Cable Loss (dB)
 2. Peak/AVG (dBμV/m)= Corr. (dB/m)+ Read Level (dBμV)
 3. Margin (dB) = Peak/AVG (dBμV/m)-Limit PK/AVG(dBμV/m)

Temperature:	25 °C	Relative Humidity:	55%
Test Voltage:	DC 3.8V		
Ant. Pol.	Horizontal		
Test Mode:	TX 802.11n(HT40) Mode 5230MHz (U-NII-1)		
Remark:	No report for the emission which more than 20 dB below the prescribed limit.		

No.	Mk.	Freq.	Reading Level	Correct Factor	Measurement	Limit	Over	Detector
		MHz	dBuV	dB/m	dBuV/m	dBuV/m	dB	
1	*	10460.424	28.06	18.27	46.33	54.00	-7.67	AVG
2		10460.484	40.66	18.27	58.93	68.30	-9.37	peak

Remark:

1. Corr. = Antenna Factor (dB/m) + Cable Loss (dB)
2. Peak/AVG (dBμV/m)= Corr. (dB/m)+ Read Level (dBμV)
3. Margin (dB) = Peak/AVG (dBμV/m)-Limit PK/AVG(dBμV/m)

Temperature:	25 °C	Relative Humidity:	55%
Test Voltage:	DC 3.8V		
Ant. Pol.	Vertical		
Test Mode:	TX 802.11n(HT40) Mode 5230MHz (U-NII-1)		
Remark:	No report for the emission which more than 20 dB below the prescribed limit.		

No.	Mk.	Freq.	Reading Level	Correct Factor	Measurement	Limit	Over	Detector
		MHz	dBuV	dB/m	dBuV/m	dBuV/m	dB	
1	*	10460.055	41.08	18.27	59.35	68.30	-8.95	peak
2		10460.055	26.31	18.27	44.58	54.00	-9.42	AVG

Remark:

1. Corr. = Antenna Factor (dB/m) + Cable Loss (dB)
2. Peak/AVG (dBμV/m)= Corr. (dB/m)+ Read Level (dBμV)
3. Margin (dB) = Peak/AVG (dBμV/m)-Limit PK/AVG(dBμV/m)

Temperature:	25 °C	Relative Humidity:	55%
Test Voltage:	DC 3.8V		
Ant. Pol.	Horizontal		
Test Mode:	TX 802.11ac(VHT40) Mode 5190MHz (U-NII-1)		
Remark:	No report for the emission which more than 20 dB below the prescribed limit.		

No.	Mk.	Freq.	Reading Level	Correct Factor	Measurement	Limit	Over	Detector
		MHz	dBuV	dB/m	dBuV/m	dBuV/m	dB	
1		10380.000	41.85	18.09	59.94	68.30	-8.36	peak
2	*	10380.000	27.60	18.09	45.69	54.00	-8.31	AVG

Remark:

1. Corr. = Antenna Factor (dB/m) + Cable Loss (dB)
2. Peak/AVG (dBμV/m)= Corr. (dB/m)+ Read Level (dBμV)
3. Margin (dB) = Peak/AVG (dBμV/m)-Limit PK/AVG(dBμV/m)

Temperature:	25 °C	Relative Humidity:	55%
Test Voltage:	DC 3.8V		
Ant. Pol.	Vertical		
Test Mode:	TX 802.11ac(VHT40) Mode 5190MHz (U-NII-1)		
Remark:	No report for the emission which more than 20 dB below the prescribed limit.		

No.	Mk.	Freq.	Reading Level	Correct Factor	Measurement	Limit	Over	Detector
		MHz	dBuV	dB/m	dBuV/m	dBuV/m	dB	
1	*	10379.787	43.14	18.09	61.23	68.30	-7.07	peak
2		10379.787	27.28	18.09	45.37	54.00	-8.63	AVG

Remark:

1. Corr. = Antenna Factor (dB/m) + Cable Loss (dB)
2. Peak/AVG (dBμV/m)= Corr. (dB/m)+ Read Level (dBμV)
3. Margin (dB) = Peak/AVG (dBμV/m)-Limit PK/AVG(dBμV/m)

Temperature:	25 °C	Relative Humidity:	55%
Test Voltage:	DC 3.8V		
Ant. Pol.	Horizontal		
Test Mode:	TX 802.11ac(VHT40) Mode 5230MHz (U-NII-1)		
Remark:	No report for the emission which more than 20 dB below the prescribed limit.		

No.	Mk.	Freq.	Reading Level	Correct Factor	Measurement	Limit	Over	Detector
		MHz	dBuV	dB/m	dBuV/m	dBuV/m	dB	
1	*	10460.034	43.59	18.27	61.86	68.30	-6.44	peak
2		10460.034	26.99	18.27	45.26	54.00	-8.74	AVG

Remark:
 1. Corr. = Antenna Factor (dB/m) + Cable Loss (dB)
 2. Peak/AVG (dBμV/m)= Corr. (dB/m)+ Read Level (dBμV)
 3. Margin (dB) = Peak/AVG (dBμV/m)-Limit PK/AVG(dBμV/m)

Temperature:	25 °C	Relative Humidity:	55%
Test Voltage:	DC 3.8V		
Ant. Pol.	Vertical		
Test Mode:	TX 802.11ac(VHT40) Mode 5230MHz (U-NII-1)		
Remark:	No report for the emission which more than 20 dB below the prescribed limit.		

No.	Mk.	Freq.	Reading Level	Correct Factor	Measurement	Limit	Over	Detector
		MHz	dBuV	dB/m	dBuV/m	dBuV/m	dB	
1		10459.739	39.45	18.27	57.72	68.30	-10.58	peak
2	*	10459.739	26.97	18.27	45.24	54.00	-8.76	AVG

Remark:
 1. Corr. = Antenna Factor (dB/m) + Cable Loss (dB)
 2. Peak/AVG (dBμV/m)= Corr. (dB/m)+ Read Level (dBμV)
 3. Margin (dB) = Peak/AVG (dBμV/m)-Limit PK/AVG(dBμV/m)

Temperature:	25 °C	Relative Humidity:	55%
Test Voltage:	DC 3.8V		
Ant. Pol.	Horizontal		
Test Mode:	TX 802.11ac(VHT80) Mode 5210MHz (U-NII-1)		
Remark:	No report for the emission which more than 20 dB below the prescribed limit.		

No.	Mk.	Freq.	Reading Level	Correct Factor	Measurement	Limit	Over	Detector
		MHz	dBuV	dB/m	dBuV/m	dBuV/m	dB	
1		10419.812	40.24	18.19	58.43	68.30	-9.87	peak
2	*	10419.812	27.17	18.19	45.36	54.00	-8.64	AVG

Remark:
1. Corr. = Antenna Factor (dB/m) + Cable Loss (dB)
2. Peak/AVG (dBµV/m)= Corr. (dB/m)+ Read Level (dBµV)
3. Margin (dB) = Peak/AVG (dBµV/m)-Limit PK/AVG(dBµV/m)

Temperature:	25 °C	Relative Humidity:	55%
Test Voltage:	DC 3.8V		
Ant. Pol.	Vertical		
Test Mode:	TX 802.11ac(VHT80) Mode 5210MHz (U-NII-1)		
Remark:	No report for the emission which more than 20 dB below the prescribed limit.		

No.	Mk.	Freq.	Reading Level	Correct Factor	Measurement	Limit	Over	Detector
		MHz	dBuV	dB/m	dBuV/m	dBuV/m	dB	
1		10419.365	40.24	18.19	58.43	68.30	-9.87	peak
2	*	10419.752	26.17	18.19	44.36	54.00	-9.64	AVG

Remark:
1. Corr. = Antenna Factor (dB/m) + Cable Loss (dB)
2. Peak/AVG (dBµV/m)= Corr. (dB/m)+ Read Level (dBµV)
3. Margin (dB) = Peak/AVG (dBµV/m)-Limit PK/AVG(dBµV/m)

5260MHz-5320MHz(U-NII-2A)

Temperature:	25 °C	Relative Humidity:	55%
Test Voltage:	DC 3.8V		
Ant. Pol.	Horizontal		
Test Mode:	TX 802.11a Mode 5260MHz (U-NII-2A)		
Remark:	No report for the emission which more than 20 dB below the prescribed limit. Only worse case is reported.		

No.	Mk.	Freq.	Reading Level	Correct Factor	Measurement	Limit	Over	Detector
		MHz	dBuV	dB/m	dBuV/m	dBuV/m	dB	
1		10520.083	39.63	18.38	58.01	68.30	-10.29	peak
2	*	10520.083	26.83	18.38	45.21	54.00	-8.79	AVG

Remark:
 1. Corr. = Antenna Factor (dB/m) + Cable Loss (dB)
 2. Peak/AVG (dBμV/m)= Corr. (dB/m)+ Read Level (dBμV)
 3. Margin (dB) = Peak/AVG (dBμV/m)-Limit PK/AVG(dBμV/m)

Temperature:	25 °C	Relative Humidity:	55%
Test Voltage:	DC 3.8V		
Ant. Pol.	Vertical		
Test Mode:	TX 802.11a Mode 5260MHz (U-NII-2A)		
Remark:	No report for the emission which more than 20 dB below the prescribed limit. Only worse case is reported.		

No.	Mk.	Freq.	Reading Level	Correct Factor	Measurement	Limit	Over	Detector
		MHz	dBuV	dB/m	dBuV/m	dBuV/m	dB	
1		10519.614	38.67	18.38	57.05	68.30	-11.25	peak
2	*	10519.614	25.87	18.38	44.25	54.00	-9.75	AVG

Remark:
 1. Corr. = Antenna Factor (dB/m) + Cable Loss (dB)
 2. Peak/AVG (dBμV/m)= Corr. (dB/m)+ Read Level (dBμV)
 3. Margin (dB) = Peak/AVG (dBμV/m)-Limit PK/AVG(dBμV/m)

Temperature:	25 °C	Relative Humidity:	55%
Test Voltage:	DC 3.8V		
Ant. Pol.	Horizontal		
Test Mode:	TX 802.11a Mode 5280MHz (U-NII-2A)		
Remark:	No report for the emission which more than 20 dB below the prescribed limit.		

No.	Mk.	Freq.	Reading Level	Correct Factor	Measurement	Limit	Over	Detector
		MHz	dBuV	dB/m	dBuV/m	dBuV/m	dB	
1		10560.323	26.93	18.43	45.36	54.00	-8.64	AVG
2	*	10560.355	43.53	18.43	61.96	68.30	-6.34	peak

Remark:

1. Corr. = Antenna Factor (dB/m) + Cable Loss (dB)
2. Peak/AVG (dBµV/m)= Corr. (dB/m)+ Read Level (dBµV)
3. Margin (dB) = Peak/AVG (dBµV/m)-Limit PK/AVG(dBµV/m)

Temperature:	25 °C	Relative Humidity:	55%
Test Voltage:	DC 3.8V		
Ant. Pol.	Vertical		
Test Mode:	TX 802.11a Mode 5280MHz (U-NII-2A)		
Remark:	No report for the emission which more than 20 dB below the prescribed limit.		

No.	Mk.	Freq.	Reading Level	Correct Factor	Measurement	Limit	Over	Detector
		MHz	dBuV	dB/m	dBuV/m	dBuV/m	dB	
1	*	10559.590	42.66	18.43	61.09	68.30	-7.21	peak
2		10559.631	27.88	18.43	46.31	54.00	-7.69	AVG

Remark:

1. Corr. = Antenna Factor (dB/m) + Cable Loss (dB)
2. Peak/AVG (dBµV/m)= Corr. (dB/m)+ Read Level (dBµV)
3. Margin (dB) = Peak/AVG (dBµV/m)-Limit PK/AVG(dBµV/m)

Temperature:	25 °C	Relative Humidity:	55%
Test Voltage:	DC 3.8V		
Ant. Pol.	Horizontal		
Test Mode:	TX 802.11a Mode 5320MHz (U-NII-2A)		
Remark:	No report for the emission which more than 20 dB below the prescribed limit.		

No.	Mk.	Freq.	Reading Level	Correct Factor	Measurement	Limit	Over	Detector
		MHz	dBuV	dB/m	dBuV/m	dBuV/m	dB	
1		10640.024	24.66	18.55	43.21	54.00	-10.79	AVG
2	*	10640.087	42.82	18.55	61.37	68.30	-6.93	peak

Remark:

1. Corr. = Antenna Factor (dB/m) + Cable Loss (dB)
2. Peak/AVG (dBuV/m)= Corr. (dB/m)+ Read Level (dBuV)
3. Margin (dB) = Peak/AVG (dBuV/m)-Limit PK/AVG(dBuV/m)

Temperature:	25 °C	Relative Humidity:	55%
Test Voltage:	DC 3.8V		
Ant. Pol.	Vertical		
Test Mode:	TX 802.11a Mode 5320MHz (U-NII-2A)		
Remark:	No report for the emission which more than 20 dB below the prescribed limit.		

No.	Mk.	Freq.	Reading Level	Correct Factor	Measurement	Limit	Over	Detector
		MHz	dBuV	dB/m	dBuV/m	dBuV/m	dB	
1	*	10639.325	26.66	18.55	45.21	54.00	-8.79	AVG
2		10639.768	40.43	18.55	58.98	68.30	-9.32	peak

Remark:

1. Corr. = Antenna Factor (dB/m) + Cable Loss (dB)
2. Peak/AVG (dBuV/m)= Corr. (dB/m)+ Read Level (dBuV)
3. Margin (dB) = Peak/AVG (dBuV/m)-Limit PK/AVG(dBuV/m)

Temperature:	25 °C	Relative Humidity:	55%
Test Voltage:	DC 3.8V		
Ant. Pol.	Horizontal		
Test Mode:	TX 802.11n(HT20) Mode 5260MHz (U-NII-2A)		
Remark:	No report for the emission which more than 20 dB below the prescribed limit.		

No.	Mk.	Freq.	Reading Level	Correct Factor	Measurement	Limit	Over	Detector
		MHz	dBuV	dB/m	dBuV/m	dBuV/m	dB	
1	*	10520.021	27.94	18.38	46.32	54.00	-7.68	AVG
2		10520.024	39.67	18.38	58.05	68.30	-10.25	peak

Remark:

1. Corr. = Antenna Factor (dB/m) + Cable Loss (dB)
2. Peak/AVG (dBµV/m)= Corr. (dB/m)+ Read Level (dBµV)
3. Margin (dB) = Peak/AVG (dBµV/m)-Limit PK/AVG(dBµV/m)

Temperature:	25 °C	Relative Humidity:	55%
Test Voltage:	DC 3.8V		
Ant. Pol.	Vertical		
Test Mode:	TX 802.11n(HT20) Mode 5260MHz (U-NII-2A)		
Remark:	No report for the emission which more than 20 dB below the prescribed limit.		

No.	Mk.	Freq.	Reading Level	Correct Factor	Measurement	Limit	Over	Detector
		MHz	dBuV	dB/m	dBuV/m	dBuV/m	dB	
1	*	10520.230	43.34	18.38	61.72	68.30	-6.58	peak
2		10520.241	26.95	18.38	45.33	54.00	-8.67	AVG

Remark:

1. Corr. = Antenna Factor (dB/m) + Cable Loss (dB)
2. Peak/AVG (dBµV/m)= Corr. (dB/m)+ Read Level (dBµV)
3. Margin (dB) = Peak/AVG (dBµV/m)-Limit PK/AVG(dBµV/m)

Temperature:	25 °C	Relative Humidity:	55%
Test Voltage:	DC 3.8V		
Ant. Pol.	Horizontal		
Test Mode:	TX 802.11n(HT20) Mode 5280MHz (U-NII-2A)		
Remark:	No report for the emission which more than 20 dB below the prescribed limit.		

No.	Mk.	Freq.	Reading Level	Correct Factor	Measurement	Limit	Over	Detector
		MHz	dBuV	dB/m	dBuV/m	dBuV/m	dB	
1		10559.751	26.93	18.43	45.36	54.00	-8.64	AVG
2	*	10559.987	42.76	18.43	61.19	68.30	-7.11	peak

Remark:

1. Corr. = Antenna Factor (dB/m) + Cable Loss (dB)
2. Peak/AVG (dBμV/m)= Corr. (dB/m)+ Read Level (dBμV)
3. Margin (dB) = Peak/AVG (dBμV/m)-Limit PK/AVG(dBμV/m)

Temperature:	25 °C	Relative Humidity:	55%
Test Voltage:	DC 3.8V		
Ant. Pol.	Vertical		
Test Mode:	TX 802.11n(HT20) Mode 5280MHz (U-NII-2A)		
Remark:	No report for the emission which more than 20 dB below the prescribed limit.		

No.	Mk.	Freq.	Reading Level	Correct Factor	Measurement	Limit	Over	Detector
		MHz	dBuV	dB/m	dBuV/m	dBuV/m	dB	
1	*	10560.394	27.89	18.43	46.32	54.00	-7.68	AVG
2		10560.400	39.45	18.43	57.88	68.30	-10.42	peak

Remark:

1. Corr. = Antenna Factor (dB/m) + Cable Loss (dB)
2. Peak/AVG (dBμV/m)= Corr. (dB/m)+ Read Level (dBμV)
3. Margin (dB) = Peak/AVG (dBμV/m)-Limit PK/AVG(dBμV/m)

Temperature:	25 °C	Relative Humidity:	55%
Test Voltage:	DC 3.8V		
Ant. Pol.	Horizontal		
Test Mode:	TX 802.11n(HT20) Mode 5320MHz (U-NII-2A)		
Remark:	No report for the emission which more than 20 dB below the prescribed limit.		

No.	Mk.	Freq.	Reading Level	Correct Factor	Measurement	Limit	Over	Detector
		MHz	dBuV	dB/m	dBuV/m	dBuV/m	dB	
1		10640.218	39.78	18.55	58.33	68.30	-9.97	peak
2	*	10640.224	27.76	18.55	46.31	54.00	-7.69	AVG

Remark:
1. Corr. = Antenna Factor (dB/m) + Cable Loss (dB)
2. Peak/AVG (dBμV/m)= Corr. (dB/m)+ Read Level (dBμV)
3. Margin (dB) = Peak/AVG (dBμV/m)-Limit PK/AVG(dBμV/m)

Temperature:	25 °C	Relative Humidity:	55%
Test Voltage:	DC 3.8V		
Ant. Pol.	Vertical		
Test Mode:	TX 802.11n(HT20) Mode 5320MHz (U-NII-2A)		
Remark:	No report for the emission which more than 20 dB below the prescribed limit.		

No.	Mk.	Freq.	Reading Level	Correct Factor	Measurement	Limit	Over	Detector
		MHz	dBuV	dB/m	dBuV/m	dBuV/m	dB	
1		10639.512	24.66	18.55	43.21	54.00	-10.79	AVG
2	*	10639.594	42.55	18.55	61.10	68.30	-7.20	peak

Remark:
1. Corr. = Antenna Factor (dB/m) + Cable Loss (dB)
2. Peak/AVG (dBμV/m)= Corr. (dB/m)+ Read Level (dBμV)
3. Margin (dB) = Peak/AVG (dBμV/m)-Limit PK/AVG(dBμV/m)

Temperature:	25 °C	Relative Humidity:	55%
Test Voltage:	DC 3.8V		
Ant. Pol.	Horizontal		
Test Mode:	TX 802.11ac(VHT20) Mode 5260MHz (U-NII-2A)		
Remark:	No report for the emission which more than 20 dB below the prescribed limit.		

No.	Mk.	Freq.	Reading Level	Correct Factor	Measurement	Limit	Over	Detector
		MHz	dBuV	dB/m	dBuV/m	dBuV/m	dB	
1		10519.244	26.93	18.38	45.31	54.00	-8.69	AVG
2	*	10519.746	42.74	18.38	61.12	68.30	-7.18	peak

Remark:

1. Corr. = Antenna Factor (dB/m) + Cable Loss (dB)
2. Peak/AVG (dBμV/m)= Corr. (dB/m)+ Read Level (dBμV)
3. Margin (dB) = Peak/AVG (dBμV/m)-Limit PK/AVG(dBμV/m)

Temperature:	25 °C	Relative Humidity:	55%
Test Voltage:	DC 3.8V		
Ant. Pol.	Vertical		
Test Mode:	TX 802.11ac(VHT20) Mode 5260MHz (U-NII-2A)		
Remark:	No report for the emission which more than 20 dB below the prescribed limit.		

No.	Mk.	Freq.	Reading Level	Correct Factor	Measurement	Limit	Over	Detector
		MHz	dBuV	dB/m	dBuV/m	dBuV/m	dB	
1	*	10520.334	24.86	18.38	43.24	54.00	-10.76	AVG
2		10520.337	37.98	18.38	56.36	68.30	-11.94	peak

Remark:

1. Corr. = Antenna Factor (dB/m) + Cable Loss (dB)
2. Peak/AVG (dBμV/m)= Corr. (dB/m)+ Read Level (dBμV)
3. Margin (dB) = Peak/AVG (dBμV/m)-Limit PK/AVG(dBμV/m)

Temperature:	25 °C	Relative Humidity:	55%
Test Voltage:	DC 3.8V		
Ant. Pol.	Horizontal		
Test Mode:	TX 802.11ac(VHT20) Mode 5280MHz (U-NII-2A)		
Remark:	No report for the emission which more than 20 dB below the prescribed limit.		

No.	Mk.	Freq.	Reading Level	Correct Factor	Measurement	Limit	Over	Detector
		MHz	dBuV	dB/m	dBuV/m	dBuV/m	dB	
1	*	10559.731	26.93	18.43	45.36	54.00	-8.64	AVG
2		10559.768	39.01	18.43	57.44	68.30	-10.86	peak

Remark:
1. Corr. = Antenna Factor (dB/m) + Cable Loss (dB)
2. Peak/AVG (dBμV/m)= Corr. (dB/m)+ Read Level (dBμV)
3. Margin (dB) = Peak/AVG (dBμV/m)-Limit PK/AVG(dBμV/m)

Temperature:	25 °C	Relative Humidity:	55%
Test Voltage:	DC 3.8V		
Ant. Pol.	Vertical		
Test Mode:	TX 802.11ac(VHT20) Mode 5280MHz (U-NII-2A)		
Remark:	No report for the emission which more than 20 dB below the prescribed limit.		

No.	Mk.	Freq.	Reading Level	Correct Factor	Measurement	Limit	Over	Detector
		MHz	dBuV	dB/m	dBuV/m	dBuV/m	dB	
1		10560.112	25.90	18.43	44.33	54.00	-9.67	AVG
2	*	10560.120	42.23	18.43	60.66	68.30	-7.64	peak

Remark:
1. Corr. = Antenna Factor (dB/m) + Cable Loss (dB)
2. Peak/AVG (dBμV/m)= Corr. (dB/m)+ Read Level (dBμV)
3. Margin (dB) = Peak/AVG (dBμV/m)-Limit PK/AVG(dBμV/m)

Temperature:	25 °C	Relative Humidity:	55%
Test Voltage:	DC 3.8V		
Ant. Pol.	Horizontal		
Test Mode:	TX 802.11 ac(VHT20) Mode 5320MHz (U-NII-2A)		
Remark:	No report for the emission which more than 20 dB below the prescribed limit.		

No.	Mk.	Freq.	Reading Level	Correct Factor	Measurement	Limit	Over	Detector
		MHz	dBuV	dB/m	dBuV/m	dBuV/m	dB	
1	*	10640.132	27.83	18.55	46.38	54.00	-7.62	AVG
2		10640.146	41.91	18.55	60.46	68.30	-7.84	peak

Remark:

1. Corr. = Antenna Factor (dB/m) + Cable Loss (dB)
2. Peak/AVG (dBμV/m)= Corr. (dB/m)+ Read Level (dBμV)
3. Margin (dB) = Peak/AVG (dBμV/m)-Limit PK/AVG(dBμV/m)

Temperature:	25 °C	Relative Humidity:	55%
Test Voltage:	DC 3.8V		
Ant. Pol.	Vertical		
Test Mode:	TX 802.11ac(VHT20) Mode 5320MHz (U-NII-2A)		
Remark:	No report for the emission which more than 20 dB below the prescribed limit.		

No.	Mk.	Freq.	Reading Level	Correct Factor	Measurement	Limit	Over	Detector
		MHz	dBuV	dB/m	dBuV/m	dBuV/m	dB	
1	*	10639.314	26.76	18.55	45.31	54.00	-8.69	AVG
2		10639.980	38.51	18.55	57.06	68.30	-11.24	peak

Remark:

1. Corr. = Antenna Factor (dB/m) + Cable Loss (dB)
2. Peak/AVG (dBμV/m)= Corr. (dB/m)+ Read Level (dBμV)
3. Margin (dB) = Peak/AVG (dBμV/m)-Limit PK/AVG(dBμV/m)

Temperature:	25 °C	Relative Humidity:	55%
Test Voltage:	DC 3.8V		
Ant. Pol.	Horizontal		
Test Mode:	TX 802.11n(HT40) Mode 5270MHz (U-NII-2A)		
Remark:	No report for the emission which more than 20 dB below the prescribed limit.		

No.	Mk.	Freq.	Reading Level	Correct Factor	Measurement	Limit	Over	Detector
		MHz	dBuV	dB/m	dBuV/m	dBuV/m	dB	
1		10540.012	26.90	18.41	45.31	54.00	-8.69	AVG
2	*	10540.089	43.57	18.41	61.98	68.30	-6.32	peak

Remark:
 1. Corr. = Antenna Factor (dB/m) + Cable Loss (dB)
 2. Peak/AVG (dBμV/m)= Corr. (dB/m)+ Read Level (dBμV)
 3. Margin (dB) = Peak/AVG (dBμV/m)-Limit PK/AVG(dBμV/m)

Temperature:	25 °C	Relative Humidity:	55%
Test Voltage:	DC 3.8V		
Ant. Pol.	Vertical		
Test Mode:	TX 802.11n(HT40) Mode 5270MHz (U-NII-2A)		
Remark:	No report for the emission which more than 20 dB below the prescribed limit.		

No.	Mk.	Freq.	Reading Level	Correct Factor	Measurement	Limit	Over	Detector
		MHz	dBuV	dB/m	dBuV/m	dBuV/m	dB	
1	*	10540.324	27.25	18.41	45.66	54.00	-8.34	AVG
2		10540.359	39.56	18.41	57.97	68.30	-10.33	peak

Remark:
 1. Corr. = Antenna Factor (dB/m) + Cable Loss (dB)
 2. Peak/AVG (dBμV/m)= Corr. (dB/m)+ Read Level (dBμV)
 3. Margin (dB) = Peak/AVG (dBμV/m)-Limit PK/AVG(dBμV/m)

Temperature:	25 °C	Relative Humidity:	55%
Test Voltage:	DC 3.8V		
Ant. Pol.	Horizontal		
Test Mode:	TX 802.11n(HT40) Mode 5310MHz (U-NII-2A)		
Remark:	No report for the emission which more than 20 dB below the prescribed limit.		

No.	Mk.	Freq.	Reading Level	Correct Factor	Measurement	Limit	Over	Detector
		MHz	dBuV	dB/m	dBuV/m	dBuV/m	dB	
1	*	10620.121	27.80	18.52	46.32	54.00	-7.68	AVG
2		10620.125	40.10	18.52	58.62	68.30	-9.68	peak

Remark:
 1. Corr. = Antenna Factor (dB/m) + Cable Loss (dB)
 2. Peak/AVG (dBμV/m)= Corr. (dB/m)+ Read Level (dBμV)
 3. Margin (dB) = Peak/AVG (dBμV/m)-Limit PK/AVG(dBμV/m)

Temperature:	25 °C	Relative Humidity:	55%
Test Voltage:	DC 3.8V		
Ant. Pol.	Vertical		
Test Mode:	TX 802.11n(HT40) Mode 5310MHz (U-NII-2A)		
Remark:	No report for the emission which more than 20 dB below the prescribed limit.		

No.	Mk.	Freq.	Reading Level	Correct Factor	Measurement	Limit	Over	Detector
		MHz	dBuV	dB/m	dBuV/m	dBuV/m	dB	
1		10620.241	26.80	18.52	45.32	54.00	-8.68	AVG
2	*	10620.381	43.32	18.52	61.84	68.30	-6.46	peak

Remark:
 1. Corr. = Antenna Factor (dB/m) + Cable Loss (dB)
 2. Peak/AVG (dBμV/m)= Corr. (dB/m)+ Read Level (dBμV)
 3. Margin (dB) = Peak/AVG (dBμV/m)-Limit PK/AVG(dBμV/m)

Temperature:	25 °C	Relative Humidity:	55%
Test Voltage:	DC 3.8V		
Ant. Pol.	Horizontal		
Test Mode:	TX 802.11ac(VHT40) Mode 5270MHz (U-NII-2A)		
Remark:	No report for the emission which more than 20 dB below the prescribed limit.		

No.	Mk.	Freq.	Reading Level	Correct Factor	Measurement	Limit	Over	Detector
		MHz	dBuV	dB/m	dBuV/m	dBuV/m	dB	
1	*	10539.618	40.14	18.41	58.55	68.30	-9.75	peak
2		10539.624	24.80	18.41	43.21	54.00	-10.79	AVG

Remark:

1. Corr. = Antenna Factor (dB/m) + Cable Loss (dB)
2. Peak/AVG (dBµV/m)= Corr. (dB/m)+ Read Level (dBµV)
3. Margin (dB) = Peak/AVG (dBµV/m)-Limit PK/AVG(dBµV/m)

Temperature:	25 °C	Relative Humidity:	55%
Test Voltage:	DC 3.8V		
Ant. Pol.	Vertical		
Test Mode:	TX 802.11ac(VHT40) Mode 5270MHz (U-NII-2A)		
Remark:	No report for the emission which more than 20 dB below the prescribed limit.		

No.	Mk.	Freq.	Reading Level	Correct Factor	Measurement	Limit	Over	Detector
		MHz	dBuV	dB/m	dBuV/m	dBuV/m	dB	
1		10539.723	24.81	18.41	43.22	54.00	-10.78	AVG
2	*	10539.767	42.71	18.41	61.12	68.30	-7.18	peak

Remark:

1. Corr. = Antenna Factor (dB/m) + Cable Loss (dB)
2. Peak/AVG (dBµV/m)= Corr. (dB/m)+ Read Level (dBµV)
3. Margin (dB) = Peak/AVG (dBµV/m)-Limit PK/AVG(dBµV/m)

Temperature:	25 °C	Relative Humidity:	55%
Test Voltage:	DC 3.8V		
Ant. Pol.	Horizontal		
Test Mode:	TX 802.11ac(VHT40) Mode 5310MHz (U-NII-2A)		
Remark:	No report for the emission which more than 20 dB below the prescribed limit.		

No.	Mk.	Freq.	Reading Level	Correct Factor	Measurement	Limit	Over	Detector
		MHz	dBuV	dB/m	dBuV/m	dBuV/m	dB	
1		10620.332	23.80	18.52	42.32	54.00	-11.68	AVG
2	*	10620.340	42.58	18.52	61.10	68.30	-7.20	peak

Remark:
 1. Corr. = Antenna Factor (dB/m) + Cable Loss (dB)
 2. Peak/AVG (dBuV/m)= Corr. (dB/m)+ Read Level (dBuV)
 3. Margin (dB) = Peak/AVG (dBuV/m)-Limit PK/AVG(dBuV/m)

Temperature:	25 °C	Relative Humidity:	55%
Test Voltage:	DC 3.8V		
Ant. Pol.	Vertical		
Test Mode:	TX 802.11ac(VHT40) Mode 5310MHz (U-NII-2A)		
Remark:	No report for the emission which more than 20 dB below the prescribed limit.		

No.	Mk.	Freq.	Reading Level	Correct Factor	Measurement	Limit	Over	Detector
		MHz	dBuV	dB/m	dBuV/m	dBuV/m	dB	
1		10619.832	23.79	18.52	42.31	54.00	-11.69	AVG
2	*	10619.890	39.78	18.52	58.30	68.30	-10.00	peak

Remark:
 1. Corr. = Antenna Factor (dB/m) + Cable Loss (dB)
 2. Peak/AVG (dBuV/m)= Corr. (dB/m)+ Read Level (dBuV)
 3. Margin (dB) = Peak/AVG (dBuV/m)-Limit PK/AVG(dBuV/m)

Temperature:	25 °C	Relative Humidity:	55%
Test Voltage:	DC 3.8V		
Ant. Pol.	Horizontal		
Test Mode:	TX 802.11ac(VHT80) Mode 5290MHz (U-NII-2A)		
Remark:	No report for the emission which more than 20 dB below the prescribed limit.		

No.	Mk.	Freq.	Reading Level	Correct Factor	Measurement	Limit	Over	Detector
		MHz	dBuV	dB/m	dBuV/m	dBuV/m	dB	
1	*	10579.621	26.66	18.46	45.12	54.00	-8.88	AVG
2		10579.631	39.20	18.46	57.66	68.30	-10.64	peak

Remark:
1. Corr. = Antenna Factor (dB/m) + Cable Loss (dB)
2. Peak/AVG (dBuV/m)= Corr. (dB/m)+ Read Level (dBuV)
3. Margin (dB) = Peak/AVG (dBuV/m)-Limit PK/AVG(dBuV/m)

Temperature:	25 °C	Relative Humidity:	55%
Test Voltage:	DC 3.8V		
Ant. Pol.	Vertical		
Test Mode:	TX 802.11ac(VHT80) Mode 5290MHz (U-NII-2A)		
Remark:	No report for the emission which more than 20 dB below the prescribed limit.		

No.	Mk.	Freq.	Reading Level	Correct Factor	Measurement	Limit	Over	Detector
		MHz	dBuV	dB/m	dBuV/m	dBuV/m	dB	
1		10579.631	26.86	18.46	45.32	54.00	-8.68	AVG
2	*	10579.639	42.95	18.46	61.41	68.30	-6.89	peak

Remark:
1. Corr. = Antenna Factor (dB/m) + Cable Loss (dB)
2. Peak/AVG (dBuV/m)= Corr. (dB/m)+ Read Level (dBuV)
3. Margin (dB) = Peak/AVG (dBuV/m)-Limit PK/AVG(dBuV/m)

5500MHz-5720MHz(U-NII-2C)

Temperature:	25 °C	Relative Humidity:	55%
Test Voltage:	DC 3.8V		
Ant. Pol.	Horizontal		
Test Mode:	TX 802.11a Mode 5500MHz (U-NII-2C)		
Remark:	No report for the emission which more than 20 dB below the prescribed limit.		

No.	Mk.	Freq.	Reading Level	Correct Factor	Measurement	Limit	Over	Detector
		MHz	dBuV	dB/m	dBuV/m	dBuV/m	dB	
1		11000.023	26.33	19.03	45.36	54.00	-8.64	AVG
2	*	11000.080	40.67	19.03	59.70	68.30	-8.60	peak

Remark:
 1. Corr. = Antenna Factor (dB/m) + Cable Loss (dB)
 2. Peak/AVG (dBuV/m)= Corr. (dB/m)+ Read Level (dBuV)
 3. Margin (dB) = Peak/AVG (dBuV/m)-Limit PK/AVG(dBuV/m)

Temperature:	25 °C	Relative Humidity:	55%
Test Voltage:	DC 3.8V		
Ant. Pol.	Vertical		
Test Mode:	TX 802.11a Mode 5500MHz (U-NII-2C)		
Remark:	No report for the emission which more than 20 dB below the prescribed limit.		

No.	Mk.	Freq.	Reading Level	Correct Factor	Measurement	Limit	Over	Detector
		MHz	dBuV	dB/m	dBuV/m	dBuV/m	dB	
1	*	10999.718	44.18	19.03	63.21	68.30	-5.09	peak
2		10999.721	26.29	19.03	45.32	54.00	-8.68	AVG

Remark:
 1. Corr. = Antenna Factor (dB/m) + Cable Loss (dB)
 2. Peak/AVG (dBuV/m)= Corr. (dB/m)+ Read Level (dBuV)
 3. Margin (dB) = Peak/AVG (dBuV/m)-Limit PK/AVG(dBuV/m)

temperature:	25 °C	Relative Humidity:	55%
Test Voltage:	DC 3.8V		
Ant. Pol.	Horizontal		
Test Mode:	TX 802.11a Mode 5600MHz (U-NII-2C)		
Remark:	No report for the emission which more than 20 dB below the prescribed limit.		

No.	Mk.	Freq.	Reading Level	Correct Factor	Measurement	Limit	Over	Detector
		MHz	dBuV	dB/m	dBuV/m	dBuV/m	dB	
1		11199.721	26.10	19.26	45.36	54.00	-8.64	AVG
2	*	11199.779	42.65	19.26	61.91	68.30	-6.39	peak

Remark:
1. Corr. = Antenna Factor (dB/m) + Cable Loss (dB)
2. Peak/AVG (dBµV/m)= Corr. (dB/m)+ Read Level (dBµV)
3. Margin (dB) = Peak/AVG (dBµV/m)-Limit PK/AVG(dBµV/m)

Temperature:	25 °C	Relative Humidity:	55%
Test Voltage:	DC 3.8V		
Ant. Pol.	Vertical		
Test Mode:	TX 802.11a Mode 5600MHz (U-NII-2C)		
Remark:	No report for the emission which more than 20 dB below the prescribed limit.		

No.	Mk.	Freq.	Reading Level	Correct Factor	Measurement	Limit	Over	Detector
		MHz	dBuV	dB/m	dBuV/m	dBuV/m	dB	
1		11199.325	25.00	19.26	44.26	54.00	-9.74	AVG
2	*	11199.843	41.12	19.26	60.38	68.30	-7.92	peak

Remark:
1. Corr. = Antenna Factor (dB/m) + Cable Loss (dB)
2. Peak/AVG (dBµV/m)= Corr. (dB/m)+ Read Level (dBµV)
3. Margin (dB) = Peak/AVG (dBµV/m)-Limit PK/AVG(dBµV/m)

Temperature:	25 °C	Relative Humidity:	55%
Test Voltage:	DC 3.8V		
Ant. Pol.	Horizontal		
Test Mode:	TX 802.11a Mode 5720MHz (U-NII-2C)		
Remark:	No report for the emission which more than 20 dB below the prescribed limit.		

No.	Mk.	Freq.	Reading Level	Correct Factor	Measurement	Limit	Over	Detector
		MHz	dBuV	dB/m	dBuV/m	dBuV/m	dB	
1		11400.021	25.82	19.50	45.32	54.00	-8.68	AVG
2	*	11400.071	40.47	19.50	59.97	68.30	-8.33	peak

Remark:

1. Corr. = Antenna Factor (dB/m) + Cable Loss (dB)
2. Peak/AVG (dBμV/m)= Corr. (dB/m)+ Read Level (dBμV)
3. Margin (dB) = Peak/AVG (dBμV/m)-Limit PK/AVG(dBμV/m)

Temperature:	25 °C	Relative Humidity:	55%
Test Voltage:	DC 3.8V		
Ant. Pol.	Vertical		
Test Mode:	TX 802.11a Mode 5720MHz (U-NII-2C)		
Remark:	No report for the emission which more than 20 dB below the prescribed limit.		

No.	Mk.	Freq.	Reading Level	Correct Factor	Measurement	Limit	Over	Detector
		MHz	dBuV	dB/m	dBuV/m	dBuV/m	dB	
1		11399.522	24.86	19.50	44.36	54.00	-9.64	AVG
2	*	11399.542	43.32	19.50	62.82	68.30	-5.48	peak

Remark:

1. Corr. = Antenna Factor (dB/m) + Cable Loss (dB)
2. Peak/AVG (dBμV/m)= Corr. (dB/m)+ Read Level (dBμV)
3. Margin (dB) = Peak/AVG (dBμV/m)-Limit PK/AVG(dBμV/m)

Temperature:	25 °C	Relative Humidity:	55%
Test Voltage:	DC 3.8V		
Ant. Pol.	Horizontal		
Test Mode:	TX 802.11n(HT20) Mode 5500MHz (U-NII-2C)		
Remark:	No report for the emission which more than 20 dB below the prescribed limit.		

No.	Mk.	Freq.	Reading Level	Correct Factor	Measurement	Limit	Over	Detector
		MHz	dBuV	dB/m	dBuV/m	dBuV/m	dB	
1		10999.812	26.33	19.03	45.36	54.00	-8.64	AVG
2	*	10999.824	43.37	19.03	62.40	68.30	-5.90	peak

Remark:

1. Corr. = Antenna Factor (dB/m) + Cable Loss (dB)
2. Peak/AVG (dBμV/m)= Corr. (dB/m)+ Read Level (dBμV)
3. Margin (dB) = Peak/AVG (dBμV/m)-Limit PK/AVG(dBμV/m)

Temperature:	25 °C	Relative Humidity:	55%
Test Voltage:	DC 3.8V		
Ant. Pol.	Vertical		
Test Mode:	TX 802.11 n(HT20) Mode 5500MHz (U-NII-2C)		
Remark:	No report for the emission which more than 20 dB below the prescribed limit.		

No.	Mk.	Freq.	Reading Level	Correct Factor	Measurement	Limit	Over	Detector
		MHz	dBuV	dB/m	dBuV/m	dBuV/m	dB	
1	*	11000.121	25.33	19.03	44.36	54.00	-9.64	AVG
2		11000.122	39.58	19.03	58.61	68.30	-9.69	peak

Remark:

1. Corr. = Antenna Factor (dB/m) + Cable Loss (dB)
2. Peak/AVG (dBμV/m)= Corr. (dB/m)+ Read Level (dBμV)
3. Margin (dB) = Peak/AVG (dBμV/m)-Limit PK/AVG(dBμV/m)

Temperature:	25 °C	Relative Humidity:	55%
Test Voltage:	DC 3.8V		
Ant. Pol.	Horizontal		
Test Mode:	TX 802.11n(HT20) Mode 5600MHz (U-NII-2C)		
Remark:	No report for the emission which more than 20 dB below the prescribed limit.		

No.	Mk.	Freq.	Reading Level	Correct Factor	Measurement	Limit	Over	Detector
		MHz	dBuV	dB/m	dBuV/m	dBuV/m	dB	
1		11199.724	25.06	19.26	44.32	54.00	-9.68	AVG
2	*	11199.784	40.56	19.26	59.82	68.30	-8.48	peak

Remark:
 1. Corr. = Antenna Factor (dB/m) + Cable Loss (dB)
 2. Peak/AVG (dBuV/m)= Corr. (dB/m)+ Read Level (dBuV)
 3. Margin (dB) = Peak/AVG (dBuV/m)-Limit PK/AVG(dBuV/m)

Temperature:	25 °C	Relative Humidity:	55%
Test Voltage:	DC 3.8V		
Ant. Pol.	Vertical		
Test Mode:	TX 802.11n(HT20) Mode 5600MHz (U-NII-2C)		
Remark:	No report for the emission which more than 20 dB below the prescribed limit.		

No.	Mk.	Freq.	Reading Level	Correct Factor	Measurement	Limit	Over	Detector
		MHz	dBuV	dB/m	dBuV/m	dBuV/m	dB	
1		11199.921	26.05	19.26	45.31	54.00	-8.69	AVG
2	*	11199.963	42.62	19.26	61.88	68.30	-6.42	peak

Remark:
 1. Corr. = Antenna Factor (dB/m) + Cable Loss (dB)
 2. Peak/AVG (dBuV/m)= Corr. (dB/m)+ Read Level (dBuV)
 3. Margin (dB) = Peak/AVG (dBuV/m)-Limit PK/AVG(dBuV/m)

Temperature:	25 °C	Relative Humidity:	55%
Test Voltage:	DC 3.8V		
Ant. Pol.	Horizontal		
Test Mode:	TX 802.11n(HT20) Mode 5720MHz (U-NII-2C)		
Remark:	No report for the emission which more than 20 dB below the prescribed limit.		

No.	Mk.	Freq.	Reading Level	Correct Factor	Measurement	Limit	Over	Detector
		MHz	dBuV	dB/m	dBuV/m	dBuV/m	dB	
1		11400.334	25.82	19.50	45.32	54.00	-8.68	AVG
2	*	11400.378	44.35	19.50	63.85	68.30	-4.45	peak

Remark:

1. Corr. = Antenna Factor (dB/m) + Cable Loss (dB)
2. Peak/AVG (dBμV/m)= Corr. (dB/m)+ Read Level (dBμV)
3. Margin (dB) = Peak/AVG (dBμV/m)-Limit PK/AVG(dBμV/m)

Temperature:	25 °C	Relative Humidity:	55%
Test Voltage:	DC 3.8V		
Ant. Pol.	Vertical		
Test Mode:	TX 802.11n(HT20) Mode 5720MHz (U-NII-2C)		
Remark:	No report for the emission which more than 20 dB below the prescribed limit.		

No.	Mk.	Freq.	Reading Level	Correct Factor	Measurement	Limit	Over	Detector
		MHz	dBuV	dB/m	dBuV/m	dBuV/m	dB	
1		11400.124	25.86	19.50	45.36	54.00	-8.64	AVG
2	*	11400.197	40.39	19.50	59.89	68.30	-8.41	peak

Remark:

1. Corr. = Antenna Factor (dB/m) + Cable Loss (dB)
2. Peak/AVG (dBμV/m)= Corr. (dB/m)+ Read Level (dBμV)
3. Margin (dB) = Peak/AVG (dBμV/m)-Limit PK/AVG(dBμV/m)

Temperature:	25 °C	Relative Humidity:	55%
Test Voltage:	DC 3.8V		
Ant. Pol.	Horizontal		
Test Mode:	TX 802.11ac(VHT20) Mode 5500MHz (U-NII-2C)		
Remark:	No report for the emission which more than 20 dB below the prescribed limit.		

No.	Mk.	Freq.	Reading Level	Correct Factor	Measurement	Limit	Over	Detector
		MHz	dBuV	dB/m	dBuV/m	dBuV/m	dB	
1		11000.223	25.31	19.03	44.34	54.00	-9.66	AVG
2	*	11000.244	42.96	19.03	61.99	68.30	-6.31	peak

Remark:

1. Corr. = Antenna Factor (dB/m) + Cable Loss (dB)
2. Peak/AVG (dBuV/m)= Corr. (dB/m)+ Read Level (dBuV)
3. Margin (dB) = Peak/AVG (dBuV/m)-Limit PK/AVG(dBuV/m)

Temperature:	25 °C	Relative Humidity:	55%
Test Voltage:	DC 3.8V		
Ant. Pol.	Vertical		
Test Mode:	TX 802.11 ac(VHT20) Mode 5500MHz (U-NII-2C)		
Remark:	No report for the emission which more than 20 dB below the prescribed limit.		

No.	Mk.	Freq.	Reading Level	Correct Factor	Measurement	Limit	Over	Detector
		MHz	dBuV	dB/m	dBuV/m	dBuV/m	dB	
1		10999.718	40.07	19.03	59.10	68.30	-9.20	peak
2	*	10999.721	26.66	19.03	45.69	54.00	-8.31	AVG

Remark:

1. Corr. = Antenna Factor (dB/m) + Cable Loss (dB)
2. Peak/AVG (dBuV/m)= Corr. (dB/m)+ Read Level (dBuV)
3. Margin (dB) = Peak/AVG (dBuV/m)-Limit PK/AVG(dBuV/m)

Temperature:	25 °C	Relative Humidity:	55%
Test Voltage:	DC 3.8V		
Ant. Pol.	Horizontal		
Test Mode:	TX 802.11 ac(VHT20) Mode 5600MHz (U-NII-2C)		
Remark:	No report for the emission which more than 20 dB below the prescribed limit.		

No.	Mk.	Freq.	Reading Level	Correct Factor	Measurement	Limit	Over	Detector
		MHz	dBuV	dB/m	dBuV/m	dBuV/m	dB	
1	*	11199.621	26.06	19.26	45.32	54.00	-8.68	AVG
2		11199.640	39.36	19.26	58.62	68.30	-9.68	peak

Remark:

1. Corr. = Antenna Factor (dB/m) + Cable Loss (dB)
2. Peak/AVG (dBμV/m)= Corr. (dB/m)+ Read Level (dBμV)
3. Margin (dB) = Peak/AVG (dBμV/m)-Limit PK/AVG(dBμV/m)

Temperature:	25 °C	Relative Humidity:	55%
Test Voltage:	DC 3.8V		
Ant. Pol.	Vertical		
Test Mode:	TX 802.11 ac(VHT20) Mode 5600MHz (U-NII-2C)		
Remark:	No report for the emission which more than 20 dB below the prescribed limit.		

No.	Mk.	Freq.	Reading Level	Correct Factor	Measurement	Limit	Over	Detector
		MHz	dBuV	dB/m	dBuV/m	dBuV/m	dB	
1	*	11199.614	42.34	19.26	61.60	68.30	-6.70	peak
2		11199.621	25.09	19.26	44.35	54.00	-9.65	AVG

Remark:

1. Corr. = Antenna Factor (dB/m) + Cable Loss (dB)
2. Peak/AVG (dBμV/m)= Corr. (dB/m)+ Read Level (dBμV)
3. Margin (dB) = Peak/AVG (dBμV/m)-Limit PK/AVG(dBμV/m)

Temperature:	25 °C	Relative Humidity:	55%
Test Voltage:	DC 3.8V		
Ant. Pol.	Horizontal		
Test Mode:	TX 802.11 ac(VHT20) Mode 5720MHz (U-NII-2C)		
Remark:	No report for the emission which more than 20 dB below the prescribed limit.		

No.	Mk.	Freq.	Reading Level	Correct Factor	Measurement	Limit	Over	Detector
		MHz	dBuV	dB/m	dBuV/m	dBuV/m	dB	
1		11440.335	23.74	19.50	43.24	54.00	-10.76	AVG
2	*	11440.379	41.03	19.50	60.53	68.30	-7.77	peak

Remark:
1. Corr. = Antenna Factor (dB/m) + Cable Loss (dB)
2. Peak/AVG (dBµV/m)= Corr. (dB/m)+ Read Level (dBµV)
3. Margin (dB) = Peak/AVG (dBµV/m)-Limit PK/AVG(dBµV/m)

Temperature:	25 °C	Relative Humidity:	55%
Test Voltage:	DC 3.8V		
Ant. Pol.	Vertical		
Test Mode:	TX 802.11 ac(VHT20) Mode 5720MHz (U-NII-2C)		
Remark:	No report for the emission which more than 20 dB below the prescribed limit.		

No.	Mk.	Freq.	Reading Level	Correct Factor	Measurement	Limit	Over	Detector
		MHz	dBuV	dB/m	dBuV/m	dBuV/m	dB	
1		11440.123	24.83	19.50	44.33	54.00	-9.67	AVG
2	*	11440.146	39.75	19.50	59.25	68.30	-9.05	peak

Remark:
1. Corr. = Antenna Factor (dB/m) + Cable Loss (dB)
2. Peak/AVG (dBµV/m)= Corr. (dB/m)+ Read Level (dBµV)
3. Margin (dB) = Peak/AVG (dBµV/m)-Limit PK/AVG(dBµV/m)

Temperature:	25 °C	Relative Humidity:	55%
Test Voltage:	DC 3.8V		
Ant. Pol.	Horizontal		
Test Mode:	TX 802.11n(HT40) Mode 5510MHz (U-NII-2C)		
Remark:	No report for the emission which more than 20 dB below the prescribed limit.		

No.	Mk.	Freq.	Reading Level	Correct Factor	Measurement	Limit	Over	Detector
		MHz	dBuV	dB/m	dBuV/m	dBuV/m	dB	
1	*	11020.309	40.42	19.06	59.48	68.30	-8.82	peak
2		11020.321	25.26	19.06	44.32	54.00	-9.68	AVG

Remark:
 1. Corr. = Antenna Factor (dB/m) + Cable Loss (dB)
 2. Peak/AVG (dBuV/m)= Corr. (dB/m)+ Read Level (dBuV)
 3. Margin (dB) = Peak/AVG (dBuV/m)-Limit PK/AVG(dBuV/m)

Temperature:	25 °C	Relative Humidity:	55%
Test Voltage:	DC 3.8V		
Ant. Pol.	Vertical		
Test Mode:	TX 802.11n(HT40) Mode 5510MHz (U-NII-2C)		
Remark:	No report for the emission which more than 20 dB below the prescribed limit.		

No.	Mk.	Freq.	Reading Level	Correct Factor	Measurement	Limit	Over	Detector
		MHz	dBuV	dB/m	dBuV/m	dBuV/m	dB	
1		11019.521	25.28	19.05	44.33	54.00	-9.67	AVG
2	*	11019.573	43.12	19.05	62.17	68.30	-6.13	peak

Remark:
 1. Corr. = Antenna Factor (dB/m) + Cable Loss (dB)
 2. Peak/AVG (dBuV/m)= Corr. (dB/m)+ Read Level (dBuV)
 3. Margin (dB) = Peak/AVG (dBuV/m)-Limit PK/AVG(dBuV/m)

Temperature:	25 °C	Relative Humidity:	55%
Test Voltage:	DC 3.8V		
Ant. Pol.	Horizontal		
Test Mode:	TX 802.11n(HT40) Mode 5590MHz (U-NII-2C)		
Remark:	No report for the emission which more than 20 dB below the prescribed limit.		

No.	Mk.	Freq.	Reading Level	Correct Factor	Measurement	Limit	Over	Detector
		MHz	dBuV	dB/m	dBuV/m	dBuV/m	dB	
1		11179.912	25.08	19.24	44.32	54.00	-9.68	AVG
2	*	11179.939	42.23	19.24	61.47	68.30	-6.83	peak

Remark:

1. Corr. = Antenna Factor (dB/m) + Cable Loss (dB)
2. Peak/AVG (dBuV/m)= Corr. (dB/m)+ Read Level (dBuV)
3. Margin (dB) = Peak/AVG (dBuV/m)-Limit PK/AVG(dBuV/m)

Temperature:	25 °C	Relative Humidity:	55%
Test Voltage:	DC 3.8V		
Ant. Pol.	Vertical		
Test Mode:	TX 802.11n(HT40) Mode 5590MHz (U-NII-2C)		
Remark:	No report for the emission which more than 20 dB below the prescribed limit.		

No.	Mk.	Freq.	Reading Level	Correct Factor	Measurement	Limit	Over	Detector
		MHz	dBuV	dB/m	dBuV/m	dBuV/m	dB	
1		11179.724	24.03	19.24	43.27	54.00	-10.73	AVG
2	*	11179.803	38.73	19.24	57.97	68.30	-10.33	peak

Remark:

1. Corr. = Antenna Factor (dB/m) + Cable Loss (dB)
2. Peak/AVG (dBuV/m)= Corr. (dB/m)+ Read Level (dBuV)
3. Margin (dB) = Peak/AVG (dBuV/m)-Limit PK/AVG(dBuV/m)

Temperature:	25 °C	Relative Humidity:	55%
Test Voltage:	DC 3.8V		
Ant. Pol.	Horizontal		
Test Mode:	TX 802.11n(HT40) Mode 5710MHz (U-NII-2C)		
Remark:	No report for the emission which more than 20 dB below the prescribed limit.		

No.	Mk.	Freq.	Reading Level	Correct Factor	Measurement	Limit	Over	Detector
		MHz	dBuV	dB/m	dBuV/m	dBuV/m	dB	
1		11420.224	24.91	19.42	44.33	54.00	-9.67	AVG
2	*	11420.271	40.42	19.42	59.84	68.30	-8.46	peak

Remark:

1. Corr. = Antenna Factor (dB/m) + Cable Loss (dB)
2. Peak/AVG (dBμV/m)= Corr. (dB/m)+ Read Level (dBμV)
3. Margin (dB) = Peak/AVG (dBμV/m)-Limit PK/AVG(dBμV/m)

Temperature:	25 °C	Relative Humidity:	55%
Test Voltage:	DC 3.8V		
Ant. Pol.	Vertical		
Test Mode:	TX 802.11n(HT40) Mode 5710MHz (U-NII-2C)		
Remark:	No report for the emission which more than 20 dB below the prescribed limit.		

No.	Mk.	Freq.	Reading Level	Correct Factor	Measurement	Limit	Over	Detector
		MHz	dBuV	dB/m	dBuV/m	dBuV/m	dB	
1	*	11419.821	43.44	19.42	62.86	68.30	-5.44	peak
2		11419.831	23.90	19.42	43.32	54.00	-10.68	AVG

Remark:

1. Corr. = Antenna Factor (dB/m) + Cable Loss (dB)
2. Peak/AVG (dBμV/m)= Corr. (dB/m)+ Read Level (dBμV)
3. Margin (dB) = Peak/AVG (dBμV/m)-Limit PK/AVG(dBμV/m)

Temperature:	25 °C	Relative Humidity:	55%
Test Voltage:	DC 3.8V		
Ant. Pol.	Horizontal		
Test Mode:	TX 802.11ac(VHT40) Mode 5510MHz (U-NII-2C)		
Remark:	No report for the emission which more than 20 dB below the prescribed limit.		

No.	Mk.	Freq.	Reading Level	Correct Factor	Measurement	Limit	Over	Detector
		MHz	dBuV	dB/m	dBuV/m	dBuV/m	dB	
1	*	11019.568	25.30	19.05	44.35	54.00	-9.65	AVG
2		11019.597	39.11	19.05	58.16	68.30	-10.14	peak

Remark:

1. Corr. = Antenna Factor (dB/m) + Cable Loss (dB)
2. Peak/AVG (dBμV/m)= Corr. (dB/m)+ Read Level (dBμV)
3. Margin (dB) = Peak/AVG (dBμV/m)-Limit PK/AVG(dBμV/m)

Temperature:	25 °C	Relative Humidity:	55%
Test Voltage:	DC 3.8V		
Ant. Pol.	Vertical		
Test Mode:	TX 802.11ac(VHT40) Mode 5510MHz (U-NII-2C)		
Remark:	No report for the emission which more than 20 dB below the prescribed limit.		

No.	Mk.	Freq.	Reading Level	Correct Factor	Measurement	Limit	Over	Detector
		MHz	dBuV	dB/m	dBuV/m	dBuV/m	dB	
1		11019.802	25.19	19.06	44.25	54.00	-9.75	AVG
2	*	11019.817	43.91	19.06	62.97	68.30	-5.33	peak

Remark:

1. Corr. = Antenna Factor (dB/m) + Cable Loss (dB)
2. Peak/AVG (dBμV/m)= Corr. (dB/m)+ Read Level (dBμV)
3. Margin (dB) = Peak/AVG (dBμV/m)-Limit PK/AVG(dBμV/m)

Temperature:	25 °C	Relative Humidity:	55%
Test Voltage:	DC 3.8V		
Ant. Pol.	Horizontal		
Test Mode:	TX 802.11ac(VHT40) Mode 5590MHz (U-NII-2C)		
Remark:	No report for the emission which more than 20 dB below the prescribed limit.		

No.	Mk.	Freq.	Reading Level	Correct Factor	Measurement	Limit	Over	Detector
		MHz	dBuV	dB/m	dBuV/m	dBuV/m	dB	
1	*	11180.129	43.19	19.24	62.43	68.30	-5.87	peak
2		11180.134	26.00	19.24	45.24	54.00	-8.76	AVG

Remark:

1. Corr. = Antenna Factor (dB/m) + Cable Loss (dB)
2. Peak/AVG (dBuV/m)= Corr. (dB/m)+ Read Level (dBuV)
3. Margin (dB) = Peak/AVG (dBuV/m)-Limit PK/AVG(dBuV/m)

Temperature:	25 °C	Relative Humidity:	55%
Test Voltage:	DC 3.8V		
Ant. Pol.	Vertical		
Test Mode:	TX 802.11ac(VHT40) Mode 5590MHz (U-NII-2C)		
Remark:	No report for the emission which more than 20 dB below the prescribed limit.		

No.	Mk.	Freq.	Reading Level	Correct Factor	Measurement	Limit	Over	Detector
		MHz	dBuV	dB/m	dBuV/m	dBuV/m	dB	
1		11179.635	25.11	19.24	44.35	54.00	-9.65	AVG
2	*	11179.687	40.09	19.24	59.33	68.30	-8.97	peak

Remark:

1. Corr. = Antenna Factor (dB/m) + Cable Loss (dB)
2. Peak/AVG (dBuV/m)= Corr. (dB/m)+ Read Level (dBuV)
3. Margin (dB) = Peak/AVG (dBuV/m)-Limit PK/AVG(dBuV/m)

Temperature:	25 °C	Relative Humidity:	55%
Test Voltage:	DC 3.8V		
Ant. Pol.	Horizontal		
Test Mode:	TX 802.11ac(VHT40) Mode 5710MHz (U-NII-2C)		
Remark:	No report for the emission which more than 20 dB below the prescribed limit.		

No.	Mk.	Freq.	Reading Level	Correct Factor	Measurement	Limit	Over	Detector
		MHz	dBuV	dB/m	dBuV/m	dBuV/m	dB	
1		11419.524	25.94	19.42	45.36	54.00	-8.64	AVG
2	*	11419.545	40.96	19.42	60.38	68.30	-7.92	peak

Remark:

1. Corr. = Antenna Factor (dB/m) + Cable Loss (dB)
2. Peak/AVG (dBμV/m)= Corr. (dB/m)+ Read Level (dBμV)
3. Margin (dB) = Peak/AVG (dBμV/m)-Limit PK/AVG(dBμV/m)

Temperature:	25 °C	Relative Humidity:	55%
Test Voltage:	DC 3.8V		
Ant. Pol.	Vertical		
Test Mode:	TX 802.11ac(VHT40) Mode 5710MHz (U-NII-2C)		
Remark:	No report for the emission which more than 20 dB below the prescribed limit.		

No.	Mk.	Freq.	Reading Level	Correct Factor	Measurement	Limit	Over	Detector
		MHz	dBuV	dB/m	dBuV/m	dBuV/m	dB	
1		11419.935	24.90	19.42	44.32	54.00	-9.68	AVG
2	*	11419.955	41.07	19.42	60.49	68.30	-7.81	peak

Remark:

1. Corr. = Antenna Factor (dB/m) + Cable Loss (dB)
2. Peak/AVG (dBμV/m)= Corr. (dB/m)+ Read Level (dBμV)
3. Margin (dB) = Peak/AVG (dBμV/m)-Limit PK/AVG(dBμV/m)

Temperature:	25 °C	Relative Humidity:	55%
Test Voltage:	DC 3.8V		
Ant. Pol.	Horizontal		
Test Mode:	TX 802.11ac(VHT80) Mode 5530MHz (U-NII-2C)		
Remark:	No report for the emission which more than 20 dB below the prescribed limit.		

No.	Mk.	Freq.	Reading Level	Correct Factor	Measurement	Limit	Over	Detector
		MHz	dBuV	dB/m	dBuV/m	dBuV/m	dB	
1	*	11059.595	41.73	19.11	60.84	68.30	-7.46	peak
2		11059.684	25.26	19.11	44.37	54.00	-9.63	AVG

Remark:
 1. Corr. = Antenna Factor (dB/m) + Cable Loss (dB)
 2. Peak/AVG (dBµV/m)= Corr. (dB/m)+ Read Level (dBµV)
 3. Margin (dB) = Peak/AVG (dBµV/m)-Limit PK/AVG(dBµV/m)

Temperature:	25 °C	Relative Humidity:	55%
Test Voltage:	DC 3.8V		
Ant. Pol.	Vertical		
Test Mode:	TX 802.11ac(VHT80) Mode 5530MHz (U-NII-2C)		
Remark:	No report for the emission which more than 20 dB below the prescribed limit.		

No.	Mk.	Freq.	Reading Level	Correct Factor	Measurement	Limit	Over	Detector
		MHz	dBuV	dB/m	dBuV/m	dBuV/m	dB	
1		11059.537	26.23	19.11	45.34	54.00	-8.66	AVG
2	*	11059.593	41.20	19.11	60.31	68.30	-7.99	peak

Remark:
 1. Corr. = Antenna Factor (dB/m) + Cable Loss (dB)
 2. Peak/AVG (dBµV/m)= Corr. (dB/m)+ Read Level (dBµV)
 3. Margin (dB) = Peak/AVG (dBµV/m)-Limit PK/AVG(dBµV/m)

Temperature:	25 °C	Relative Humidity:	55%
Test Voltage:	DC 3.8V		
Ant. Pol.	Horizontal		
Test Mode:	TX 802.11ac(VHT80) Mode 5610MHz (U-NII-2C)		
Remark:	No report for the emission which more than 20 dB below the prescribed limit.		

No.	Mk.	Freq.	Reading Level	Correct Factor	Measurement	Limit	Over	Detector
		MHz	dBuV	dB/m	dBuV/m	dBuV/m	dB	
1	*	11220.198	40.56	19.29	59.85	68.30	-8.45	peak
2		11220.203	25.04	19.29	44.33	54.00	-9.67	AVG

Remark:

1. Corr. = Antenna Factor (dB/m) + Cable Loss (dB)
2. Peak/AVG (dBuV/m)= Corr. (dB/m)+ Read Level (dBuV)
3. Margin (dB) = Peak/AVG (dBuV/m)-Limit PK/AVG(dBuV/m)

Temperature:	25 °C	Relative Humidity:	55%
Test Voltage:	DC 3.8V		
Ant. Pol.	Vertical		
Test Mode:	TX 802.11ac(VHT80) Mode 5610MHz (U-NII-2C)		
Remark:	No report for the emission which more than 20 dB below the prescribed limit.		

No.	Mk.	Freq.	Reading Level	Correct Factor	Measurement	Limit	Over	Detector
		MHz	dBuV	dB/m	dBuV/m	dBuV/m	dB	
1	*	11220.418	43.71	19.29	63.00	68.30	-5.30	peak
2		11220.435	26.06	19.29	45.35	54.00	-8.65	AVG

Remark:

1. Corr. = Antenna Factor (dB/m) + Cable Loss (dB)
2. Peak/AVG (dBuV/m)= Corr. (dB/m)+ Read Level (dBuV)
3. Margin (dB) = Peak/AVG (dBuV/m)-Limit PK/AVG(dBuV/m)

Temperature:	25 °C	Relative Humidity:	55%
Test Voltage:	DC 3.8V		
Ant. Pol.	Horizontal		
Test Mode:	TX 802.11ac(VHT80) Mode 5690MHz (U-NII-2C)		
Remark:	No report for the emission which more than 20 dB below the prescribed limit.		

No.	Mk.	Freq.	Reading Level	Correct Factor	Measurement	Limit	Over	Detector
		MHz	dBuV	dB/m	dBuV/m	dBuV/m	dB	
1		11379.754	23.78	19.47	43.25	54.00	-10.75	AVG
2	*	11379.886	40.35	19.47	59.82	68.30	-8.48	peak

Remark:

1. Corr. = Antenna Factor (dB/m) + Cable Loss (dB)
2. Peak/AVG (dBμV/m)= Corr. (dB/m)+ Read Level (dBμV)
3. Margin (dB) = Peak/AVG (dBμV/m)-Limit PK/AVG(dBμV/m)

Temperature:	25 °C	Relative Humidity:	55%
Test Voltage:	DC 3.8V		
Ant. Pol.	Vertical		
Test Mode:	TX 802.11ac(VHT80) Mode 5690MHz (U-NII-2C)		
Remark:	No report for the emission which more than 20 dB below the prescribed limit.		

No.	Mk.	Freq.	Reading Level	Correct Factor	Measurement	Limit	Over	Detector
		MHz	dBuV	dB/m	dBuV/m	dBuV/m	dB	
1	*	11379.605	41.95	19.47	61.42	68.30	-6.88	peak
2		11379.635	25.85	19.47	45.32	54.00	-8.68	AVG

Remark:

1. Corr. = Antenna Factor (dB/m) + Cable Loss (dB)
2. Peak/AVG (dBμV/m)= Corr. (dB/m)+ Read Level (dBμV)
3. Margin (dB) = Peak/AVG (dBμV/m)-Limit PK/AVG(dBμV/m)

5745MHz-5825MHz(U-NII-3)

Temperature:	25 °C	Relative Humidity:	55%
Test Voltage:	DC 3.8V		
Ant. Pol.	Horizontal		
Test Mode:	TX 802.11a Mode 5745MHz (U-NII-3)		
Remark:	No report for the emission which more than 20 dB below the prescribed limit.		

No.	Mk.	Freq.	Reading Level	Correct Factor	Measurement	Limit	Over	Detector
		MHz	dBuV	dB/m	dBuV/m	dBuV/m	dB	
1	*	11489.751	25.76	19.60	45.36	54.00	-8.64	AVG
2		11489.835	38.74	19.60	58.34	68.30	-9.96	peak

Remark:

1. Corr. = Antenna Factor (dB/m) + Cable Loss (dB)
2. Peak/AVG (dBμV/m)= Corr. (dB/m)+ Read Level (dBμV)
3. Margin (dB) = Peak/AVG (dBμV/m)-Limit PK/AVG(dBμV/m)

Temperature:	25 °C	Relative Humidity:	55%
Test Voltage:	DC 3.8V		
Ant. Pol.	Vertical		
Test Mode:	TX 802.11a Mode 5745MHz (U-NII-3)		
Remark:	No report for the emission which more than 20 dB below the prescribed limit.		

No.	Mk.	Freq.	Reading Level	Correct Factor	Measurement	Limit	Over	Detector
		MHz	dBuV	dB/m	dBuV/m	dBuV/m	dB	
1		11490.241	25.72	19.60	45.32	54.00	-8.68	AVG
2	*	11490.438	42.50	19.60	62.10	68.30	-6.20	peak

Remark:

1. Corr. = Antenna Factor (dB/m) + Cable Loss (dB)
2. Peak/AVG (dBμV/m)= Corr. (dB/m)+ Read Level (dBμV)
3. Margin (dB) = Peak/AVG (dBμV/m)-Limit PK/AVG(dBμV/m)

Temperature:	25 °C	Relative Humidity:	55%
Test Voltage:	DC 3.8V		
Ant. Pol.	Horizontal		
Test Mode:	TX 802.11a Mode 5785MHz (U-NII-3)		
Remark:	No report for the emission which more than 20 dB below the prescribed limit.		

No.	Mk.	Freq.	Reading Level	Correct Factor	Measurement	Limit	Over	Detector
		MHz	dBuV	dB/m	dBuV/m	dBuV/m	dB	
1		11570.024	23.56	19.68	43.24	54.00	-10.76	AVG
2	*	11570.093	43.59	19.68	63.27	68.30	-5.03	peak

Remark:
 1. Corr. = Antenna Factor (dB/m) + Cable Loss (dB)
 2. Peak/AVG (dBuV/m)= Corr. (dB/m)+ Read Level (dBuV)
 3. Margin (dB) = Peak/AVG (dBuV/m)-Limit PK/AVG(dBuV/m)

Temperature:	25 °C	Relative Humidity:	55%
Test Voltage:	DC 3.8V		
Ant. Pol.	Vertical		
Test Mode:	TX 802.11a Mode 5785MHz (U-NII-3)		
Remark:	No report for the emission which more than 20 dB below the prescribed limit.		

No.	Mk.	Freq.	Reading Level	Correct Factor	Measurement	Limit	Over	Detector
		MHz	dBuV	dB/m	dBuV/m	dBuV/m	dB	
1		11569.241	24.69	19.68	44.37	54.00	-9.63	AVG
2	*	11569.646	41.56	19.68	61.24	68.30	-7.06	peak

Remark:
 1. Corr. = Antenna Factor (dB/m) + Cable Loss (dB)
 2. Peak/AVG (dBuV/m)= Corr. (dB/m)+ Read Level (dBuV)
 3. Margin (dB) = Peak/AVG (dBuV/m)-Limit PK/AVG(dBuV/m)

Temperature:	25 °C	Relative Humidity:	55%
Test Voltage:	DC 3.8V		
Ant. Pol.	Horizontal		
Test Mode:	TX 802.11a Mode 5825MHz (U-NII-3)		
Remark:	No report for the emission which more than 20 dB below the prescribed limit.		

No.	Mk.	Freq.	Reading Level	Correct Factor	Measurement	Limit	Over	Detector
		MHz	dBuV	dB/m	dBuV/m	dBuV/m	dB	
1		11649.124	24.60	19.76	44.36	54.00	-9.64	AVG
2	*	11649.998	41.26	19.76	61.02	68.30	-7.28	peak

Remark:

1. Corr. = Antenna Factor (dB/m) + Cable Loss (dB)
2. Peak/AVG (dBμV/m)= Corr. (dB/m)+ Read Level (dBμV)
3. Margin (dB) = Peak/AVG (dBμV/m)-Limit PK/AVG(dBμV/m)

Temperature:	25 °C	Relative Humidity:	55%
Test Voltage:	DC 3.8V		
Ant. Pol.	Vertical		
Test Mode:	TX 802.11a Mode 5825MHz (U-NII-3)		
Remark:	No report for the emission which more than 20 dB below the prescribed limit.		

No.	Mk.	Freq.	Reading Level	Correct Factor	Measurement	Limit	Over	Detector
		MHz	dBuV	dB/m	dBuV/m	dBuV/m	dB	
1	*	11650.098	43.34	19.76	63.10	68.30	-5.20	peak
2		11650.121	25.56	19.76	45.32	54.00	-8.68	AVG

Remark:

1. Corr. = Antenna Factor (dB/m) + Cable Loss (dB)
2. Peak/AVG (dBμV/m)= Corr. (dB/m)+ Read Level (dBμV)
3. Margin (dB) = Peak/AVG (dBμV/m)-Limit PK/AVG(dBμV/m)

Temperature:	25 °C	Relative Humidity:	55%
Test Voltage:	DC 3.8V		
Ant. Pol.	Horizontal		
Test Mode:	TX 802.11n(HT20) Mode 5745MHz (U-NII-3)		
Remark:	No report for the emission which more than 20 dB below the prescribed limit.		

No.	Mk.	Freq.	Reading Level	Correct Factor	Measurement	Limit	Over	Detector
		MHz	dBuV	dB/m	dBuV/m	dBuV/m	dB	
1		11490.335	25.64	19.60	45.24	54.00	-8.76	AVG
2	*	11490.382	42.95	19.60	62.55	68.30	-5.75	peak

Remark:

1. Corr. = Antenna Factor (dB/m) + Cable Loss (dB)
2. Peak/AVG (dBuV/m)= Corr. (dB/m)+ Read Level (dBuV)
3. Margin (dB) = Peak/AVG (dBuV/m)-Limit PK/AVG(dBuV/m)

Temperature:	25 °C	Relative Humidity:	55%
Test Voltage:	DC 3.8V		
Ant. Pol.	Vertical		
Test Mode:	TX 802.11n(HT20) Mode 5745MHz (U-NII-3)		
Remark:	No report for the emission which more than 20 dB below the prescribed limit.		

No.	Mk.	Freq.	Reading Level	Correct Factor	Measurement	Limit	Over	Detector
		MHz	dBuV	dB/m	dBuV/m	dBuV/m	dB	
1	*	11489.451	24.72	19.60	44.32	54.00	-9.68	AVG
2		11489.537	38.74	19.60	58.34	68.30	-9.96	peak

Remark:

1. Corr. = Antenna Factor (dB/m) + Cable Loss (dB)
2. Peak/AVG (dBuV/m)= Corr. (dB/m)+ Read Level (dBuV)
3. Margin (dB) = Peak/AVG (dBuV/m)-Limit PK/AVG(dBuV/m)

Temperature:	25 °C	Relative Humidity:	55%
Test Voltage:	DC 3.8V		
Ant. Pol.	Horizontal		
Test Mode:	TX 802.11n(HT20) Mode 5785MHz (U-NII-3)		
Remark:	No report for the emission which more than 20 dB below the prescribed limit.		

No.	Mk.	Freq.	Reading Level	Correct Factor	Measurement	Limit	Over	Detector
		MHz	dBuV	dB/m	dBuV/m	dBuV/m	dB	
1	*	11569.554	39.15	19.68	58.83	68.30	-9.47	peak
2		11569.556	24.65	19.68	44.33	54.00	-9.67	AVG

Remark:
 1. Corr. = Antenna Factor (dB/m) + Cable Loss (dB)
 2. Peak/AVG (dBμV/m)= Corr. (dB/m)+ Read Level (dBμV)
 3. Margin (dB) = Peak/AVG (dBμV/m)-Limit PK/AVG(dBμV/m)

Temperature:	25 °C	Relative Humidity:	55%
Test Voltage:	DC 3.8V		
Ant. Pol.	Vertical		
Test Mode:	TX 802.11n(HT20) Mode 5785MHz (U-NII-3)		
Remark:	No report for the emission which more than 20 dB below the prescribed limit.		

No.	Mk.	Freq.	Reading Level	Correct Factor	Measurement	Limit	Over	Detector
		MHz	dBuV	dB/m	dBuV/m	dBuV/m	dB	
1	*	11569.542	40.62	19.68	60.30	68.30	-8.00	peak
2		11569.554	25.56	19.68	45.24	54.00	-8.76	AVG

Remark:
 1. Corr. = Antenna Factor (dB/m) + Cable Loss (dB)
 2. Peak/AVG (dBμV/m)= Corr. (dB/m)+ Read Level (dBμV)
 3. Margin (dB) = Peak/AVG (dBμV/m)-Limit PK/AVG(dBμV/m)

Temperature:	25 °C	Relative Humidity:	55%
Test Voltage:	DC 3.8V		
Ant. Pol.	Horizontal		
Test Mode:	TX 802.11n(HT20) Mode 5825MHz (U-NII-3)		
Remark:	No report for the emission which more than 20 dB below the prescribed limit.		

No.	Mk.	Freq.	Reading Level	Correct Factor	Measurement	Limit	Over	Detector
		MHz	dBuV	dB/m	dBuV/m	dBuV/m	dB	
1		11569.791	39.16	19.68	58.84	68.30	-9.46	peak
2	*	11569.797	25.63	19.68	45.31	54.00	-8.69	AVG

Remark:
 1. Corr. = Antenna Factor (dB/m) + Cable Loss (dB)
 2. Peak/AVG (dBuV/m)= Corr. (dB/m)+ Read Level (dBuV)
 3. Margin (dB) = Peak/AVG (dBuV/m)-Limit PK/AVG(dBuV/m)

Temperature:	25 °C	Relative Humidity:	55%
Test Voltage:	DC 3.8V		
Ant. Pol.	Vertical		
Test Mode:	TX 802.11n(HT20) Mode 5825MHz (U-NII-3)		
Remark:	No report for the emission which more than 20 dB below the prescribed limit.		

No.	Mk.	Freq.	Reading Level	Correct Factor	Measurement	Limit	Over	Detector
		MHz	dBuV	dB/m	dBuV/m	dBuV/m	dB	
1	*	11570.155	40.58	19.68	60.26	68.30	-8.04	peak
2		11570.168	25.66	19.68	45.34	54.00	-8.66	AVG

Remark:
 1. Corr. = Antenna Factor (dB/m) + Cable Loss (dB)
 2. Peak/AVG (dBuV/m)= Corr. (dB/m)+ Read Level (dBuV)
 3. Margin (dB) = Peak/AVG (dBuV/m)-Limit PK/AVG(dBuV/m)

Temperature:	25 °C	Relative Humidity:	55%
Test Voltage:	DC 3.8V		
Ant. Pol.	Horizontal		
Test Mode:	TX 802.11ac(VHT20) Mode 5745MHz (U-NII-3)		
Remark:	No report for the emission which more than 20 dB below the prescribed limit.		

No.	Mk.	Freq.	Reading Level	Correct Factor	Measurement	Limit	Over	Detector
		MHz	dBuV	dB/m	dBuV/m	dBuV/m	dB	
1	*	11490.179	39.40	19.60	59.00	68.30	-9.30	peak
2		11490.184	24.75	19.60	44.35	54.00	-9.65	AVG

Remark:

1. Corr. = Antenna Factor (dB/m) + Cable Loss (dB)
2. Peak/AVG (dBuV/m)= Corr. (dB/m)+ Read Level (dBuV)
3. Margin (dB) = Peak/AVG (dBuV/m)-Limit PK/AVG(dBuV/m)

Temperature:	25 °C	Relative Humidity:	55%
Test Voltage:	DC 3.8V		
Ant. Pol.	Vertical		
Test Mode:	TX 802.11ac(VHT20) Mode 5745MHz (U-NII-3)		
Remark:	No report for the emission which more than 20 dB below the prescribed limit.		

No.	Mk.	Freq.	Reading Level	Correct Factor	Measurement	Limit	Over	Detector
		MHz	dBuV	dB/m	dBuV/m	dBuV/m	dB	
1	*	11489.824	42.50	19.60	62.10	68.30	-6.20	peak
2		11489.865	24.75	19.60	44.35	54.00	-9.65	AVG

Remark:

1. Corr. = Antenna Factor (dB/m) + Cable Loss (dB)
2. Peak/AVG (dBuV/m)= Corr. (dB/m)+ Read Level (dBuV)
3. Margin (dB) = Peak/AVG (dBuV/m)-Limit PK/AVG(dBuV/m)

Temperature:	25 °C	Relative Humidity:	55%
Test Voltage:	DC 3.8V		
Ant. Pol.	Horizontal		
Test Mode:	TX 802.11ac(VHT20) Mode 5785MHz (U-NII-3)		
Remark:	No report for the emission which more than 20 dB below the prescribed limit.		

No.	Mk.	Freq.	Reading Level	Correct Factor	Measurement	Limit	Over	Detector
		MHz	dBuV	dB/m	dBuV/m	dBuV/m	dB	
1		11570.457	25.53	19.68	45.21	54.00	-8.79	AVG
2	*	11570.483	40.52	19.68	60.20	68.30	-8.10	peak

Remark:

1. Corr. = Antenna Factor (dB/m) + Cable Loss (dB)
2. Peak/AVG (dBμV/m)= Corr. (dB/m)+ Read Level (dBμV)
3. Margin (dB) = Peak/AVG (dBμV/m)-Limit PK/AVG(dBμV/m)

Temperature:	25 °C	Relative Humidity:	55%
Test Voltage:	DC 3.8V		
Ant. Pol.	Vertical		
Test Mode:	TX 802.11ac(VHT20) Mode 5785MHz (U-NII-3)		
Remark:	No report for the emission which more than 20 dB below the prescribed limit.		

No.	Mk.	Freq.	Reading Level	Correct Factor	Measurement	Limit	Over	Detector
		MHz	dBuV	dB/m	dBuV/m	dBuV/m	dB	
1	*	11570.006	40.88	19.68	60.56	68.30	-7.74	peak
2		11570.124	24.64	19.68	44.32	54.00	-9.68	AVG

Remark:

1. Corr. = Antenna Factor (dB/m) + Cable Loss (dB)
2. Peak/AVG (dBμV/m)= Corr. (dB/m)+ Read Level (dBμV)
3. Margin (dB) = Peak/AVG (dBμV/m)-Limit PK/AVG(dBμV/m)

Temperature:	25 °C	Relative Humidity:	55%
Test Voltage:	DC 3.8V		
Ant. Pol.	Horizontal		
Test Mode:	TX 802.11ac(VHT20) Mode 5825MHz (U-NII-3)		
Remark:	No report for the emission which more than 20 dB below the prescribed limit.		

No.	Mk.	Freq.	Reading Level	Correct Factor	Measurement	Limit	Over	Detector
		MHz	dBuV	dB/m	dBuV/m	dBuV/m	dB	
1	*	11650.138	40.32	19.76	60.08	68.30	-8.22	peak
2		11650.151	24.57	19.76	44.33	54.00	-9.67	AVG

Remark:

1. Corr. = Antenna Factor (dB/m) + Cable Loss (dB)
2. Peak/AVG (dBuV/m)= Corr. (dB/m)+ Read Level (dBuV)
3. Margin (dB) = Peak/AVG (dBuV/m)-Limit PK/AVG(dBuV/m)

Temperature:	25 °C	Relative Humidity:	55%
Test Voltage:	DC 3.8V		
Ant. Pol.	Vertical		
Test Mode:	TX 802.11ac(VHT20) Mode 5825MHz (U-NII-3)		
Remark:	No report for the emission which more than 20 dB below the prescribed limit.		

No.	Mk.	Freq.	Reading Level	Correct Factor	Measurement	Limit	Over	Detector
		MHz	dBuV	dB/m	dBuV/m	dBuV/m	dB	
1	*	11650.397	40.65	19.76	60.41	68.30	-7.89	peak
2		11650.421	24.45	19.76	44.21	54.00	-9.79	AVG

Remark:

1. Corr. = Antenna Factor (dB/m) + Cable Loss (dB)
2. Peak/AVG (dBuV/m)= Corr. (dB/m)+ Read Level (dBuV)
3. Margin (dB) = Peak/AVG (dBuV/m)-Limit PK/AVG(dBuV/m)

Temperature:	25 °C	Relative Humidity:	55%
Test Voltage:	DC 3.8V		
Ant. Pol.	Horizontal		
Test Mode:	TX 802.11n(HT40) Mode 5755MHz (U-NII-3)		
Remark:	No report for the emission which more than 20 dB below the prescribed limit.		

No.	Mk.	Freq.	Reading Level	Correct Factor	Measurement	Limit	Over	Detector
		MHz	dBuV	dB/m	dBuV/m	dBuV/m	dB	
1		11510.354	24.69	19.63	44.32	54.00	-9.68	AVG
2	*	11510.386	42.00	19.63	61.63	68.30	-6.67	peak

Remark:

1. Corr. = Antenna Factor (dB/m) + Cable Loss (dB)
2. Peak/AVG (dBuV/m)= Corr. (dB/m)+ Read Level (dBuV)
3. Margin (dB) = Peak/AVG (dBuV/m)-Limit PK/AVG(dBuV/m)

Temperature:	25 °C	Relative Humidity:	55%
Test Voltage:	DC 3.8V		
Ant. Pol.	Vertical		
Test Mode:	TX 802.11n(HT40) Mode 5755MHz (U-NII-3)		
Remark:	No report for the emission which more than 20 dB below the prescribed limit.		

No.	Mk.	Freq.	Reading Level	Correct Factor	Measurement	Limit	Over	Detector
		MHz	dBuV	dB/m	dBuV/m	dBuV/m	dB	
1	*	11509.799	43.39	19.63	63.02	68.30	-5.28	peak
2		11509.841	25.69	19.63	45.32	54.00	-8.68	AVG

Remark:

1. Corr. = Antenna Factor (dB/m) + Cable Loss (dB)
2. Peak/AVG (dBuV/m)= Corr. (dB/m)+ Read Level (dBuV)
3. Margin (dB) = Peak/AVG (dBuV/m)-Limit PK/AVG(dBuV/m)

Temperature:	25 °C	Relative Humidity:	55%
Test Voltage:	DC 3.8V		
Ant. Pol.	Horizontal		
Test Mode:	TX 802.11n(HT40) Mode 5795MHz (U-NII-3)		
Remark:	No report for the emission which more than 20 dB below the prescribed limit.		

No.	Mk.	Freq.	Reading Level	Correct Factor	Measurement	Limit	Over	Detector
		MHz	dBuV	dB/m	dBuV/m	dBuV/m	dB	
1	*	11589.670	40.79	19.69	60.48	68.30	-7.82	peak
2		11589.686	24.63	19.69	44.32	54.00	-9.68	AVG

Remark:
 1. Corr. = Antenna Factor (dB/m) + Cable Loss (dB)
 2. Peak/AVG (dBuV/m)= Corr. (dB/m)+ Read Level (dBuV)
 3. Margin (dB) = Peak/AVG (dBuV/m)-Limit PK/AVG(dBuV/m)

Temperature:	25 °C	Relative Humidity:	55%
Test Voltage:	DC 3.8V		
Ant. Pol.	Vertical		
Test Mode:	TX 802.11n(HT40) Mode 5795MHz (U-NII-3)		
Remark:	No report for the emission which more than 20 dB below the prescribed limit.		

No.	Mk.	Freq.	Reading Level	Correct Factor	Measurement	Limit	Over	Detector
		MHz	dBuV	dB/m	dBuV/m	dBuV/m	dB	
1	*	11589.814	40.14	19.69	59.83	68.30	-8.47	peak
2		11589.834	25.55	19.69	45.24	54.00	-8.76	AVG

Remark:
 1. Corr. = Antenna Factor (dB/m) + Cable Loss (dB)
 2. Peak/AVG (dBuV/m)= Corr. (dB/m)+ Read Level (dBuV)
 3. Margin (dB) = Peak/AVG (dBuV/m)-Limit PK/AVG(dBuV/m)

Temperature:	25 °C	Relative Humidity:	55%
Test Voltage:	DC 3.8V		
Ant. Pol.	Horizontal		
Test Mode:	TX 802.11ac(VHT40) Mode 5755MHz (U-NII-3)		
Remark:	No report for the emission which more than 20 dB below the prescribed limit.		

No.	Mk.	Freq.	Reading Level	Correct Factor	Measurement	Limit	Over	Detector
		MHz	dBuV	dB/m	dBuV/m	dBuV/m	dB	
1	*	11509.575	39.10	19.63	58.73	68.30	-9.57	peak
2		11509.584	24.69	19.63	44.32	54.00	-9.68	AVG

Remark:

1. Corr. = Antenna Factor (dB/m) + Cable Loss (dB)
2. Peak/AVG (dBμV/m)= Corr. (dB/m)+ Read Level (dBμV)
3. Margin (dB) = Peak/AVG (dBμV/m)-Limit PK/AVG(dBμV/m)

Temperature:	25 °C	Relative Humidity:	55%
Test Voltage:	DC 3.8V		
Ant. Pol.	Vertical		
Test Mode:	TX 802.11ac(VHT40) Mode 5755MHz (U-NII-3)		
Remark:	No report for the emission which more than 20 dB below the prescribed limit.		

No.	Mk.	Freq.	Reading Level	Correct Factor	Measurement	Limit	Over	Detector
		MHz	dBuV	dB/m	dBuV/m	dBuV/m	dB	
1	*	11509.524	40.26	19.63	59.89	68.30	-8.41	peak
2		11509.574	24.74	19.63	44.37	54.00	-9.63	AVG

Remark:

1. Corr. = Antenna Factor (dB/m) + Cable Loss (dB)
2. Peak/AVG (dBμV/m)= Corr. (dB/m)+ Read Level (dBμV)
3. Margin (dB) = Peak/AVG (dBμV/m)-Limit PK/AVG(dBμV/m)

Temperature:	25 °C	Relative Humidity:	55%
Test Voltage:	DC 3.8V		
Ant. Pol.	Horizontal		
Test Mode:	TX 802.11ac(VHT40) Mode 5795MHz (U-NII-3)		
Remark:	No report for the emission which more than 20 dB below the prescribed limit.		

No.	Mk.	Freq. MHz	Reading Level dBuV	Correct Factor dB/m	Measure- ment dBuV/m	Limit dBuV/m	Over dB	Detector
1	*	11590.339	40.57	19.69	60.26	68.30	-8.04	peak
2		11590.384	24.68	19.69	44.37	54.00	-9.63	AVG

Remark:
1. Corr. = Antenna Factor (dB/m) + Cable Loss (dB)
2. Peak/AVG (dBuV/m)= Corr. (dB/m)+ Read Level (dBuV)
3. Margin (dB) = Peak/AVG (dBuV/m)-Limit PK/AVG(dBuV/m)

Temperature:	25 °C	Relative Humidity:	55%
Test Voltage:	DC 3.8V		
Ant. Pol.	Vertical		
Test Mode:	TX 802.11ac(VHT40) Mode 5795MHz (U-NII-3)		
Remark:	No report for the emission which more than 20 dB below the prescribed limit.		

No.	Mk.	Freq. MHz	Reading Level dBuV	Correct Factor dB/m	Measure- ment dBuV/m	Limit dBuV/m	Over dB	Detector
1		11590.375	38.52	19.69	58.21	68.30	-10.09	peak
2	*	11590.386	24.63	19.69	44.32	54.00	-9.68	AVG

Remark:
1. Corr. = Antenna Factor (dB/m) + Cable Loss (dB)
2. Peak/AVG (dBuV/m)= Corr. (dB/m)+ Read Level (dBuV)
3. Margin (dB) = Peak/AVG (dBuV/m)-Limit PK/AVG(dBuV/m)

Temperature:	25 °C	Relative Humidity:	55%
Test Voltage:	DC 3.8V		
Ant. Pol.	Horizontal		
Test Mode:	TX 802.11ac(VHT80) Mode 5775MHz (U-NII-3)		
Remark:	No report for the emission which more than 20 dB below the prescribed limit.		

No.	Mk.	Freq.	Reading Level	Correct Factor	Measurement	Limit	Over	Detector
		MHz	dBuV	dB/m	dBuV/m	dBuV/m	dB	
1		11550.223	38.39	19.66	58.05	68.30	-10.25	peak
2	*	11550.235	25.66	19.66	45.32	54.00	-8.68	AVG

Remark:

1. Corr. = Antenna Factor (dB/m) + Cable Loss (dB)
2. Peak/AVG (dBμV/m)= Corr. (dB/m)+ Read Level (dBμV)
3. Margin (dB) = Peak/AVG (dBμV/m)-Limit PK/AVG(dBμV/m)

Temperature:	25 °C	Relative Humidity:	55%
Test Voltage:	DC 3.8V		
Ant. Pol.	Vertical		
Test Mode:	TX 802.11ac(VHT80) Mode 5775MHz (U-NII-3)		
Remark:	No report for the emission which more than 20 dB below the prescribed limit.		

No.	Mk.	Freq.	Reading Level	Correct Factor	Measurement	Limit	Over	Detector
		MHz	dBuV	dB/m	dBuV/m	dBuV/m	dB	
1	*	11550.242	41.15	19.66	60.81	68.30	-7.49	peak
2		11550.254	24.69	19.66	44.35	54.00	-9.65	AVG

Remark:

1. Corr. = Antenna Factor (dB/m) + Cable Loss (dB)
2. Peak/AVG (dBμV/m)= Corr. (dB/m)+ Read Level (dBμV)
3. Margin (dB) = Peak/AVG (dBμV/m)-Limit PK/AVG(dBμV/m)

Attachment C-- Restricted Bands Requirement and Band-edge Test Data

(1) Radiation Test

Temperature:	25 °C	Relative Humidity:	55%
Test Voltage:	DC 3.8V		
Ant. Pol.	Horizontal		
Test Mode:	TX 802.11a Mode 5180 MHz (U-NII-1)		
Remark:			

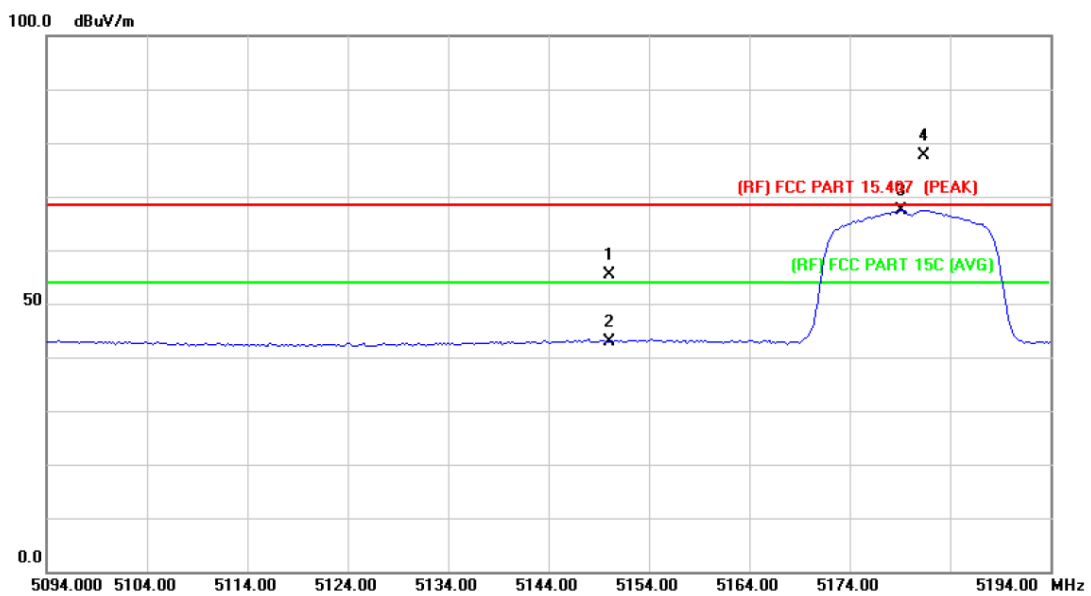

No.	Mk.	Freq. MHz	Reading Level dBuV	Correct Factor dB/m	Measure- ment dBuV/m	Limit dBuV/m	Over dB	Detector
1		5150.000	40.67	14.67	55.34	68.30	-12.96	peak
2		5150.000	28.21	14.67	42.88	54.00	-11.12	AVG
3	*	5179.200	52.75	14.72	67.47	Fundamental Frequency		AVG
4	X	5181.400	62.86	14.72	77.58	Fundamental Frequency		peak

Remark:

1. Corr. = Antenna Factor (dB/m) + Cable Loss (dB)
2. Peak/AVG (dBuV/m) = Corr. (dB/m) + Read Level (dBuV)
3. Margin (dB) = Peak/AVG (dBuV/m) - Limit PK/AVG (dBuV/m)

Temperature:	25 °C	Relative Humidity:	55%
Test Voltage:	DC 3.8V		
Ant. Pol.	Vertical		
Test Mode:	TX 802.11a Mode 5180 MHz (U-NII-1)		
Remark:			

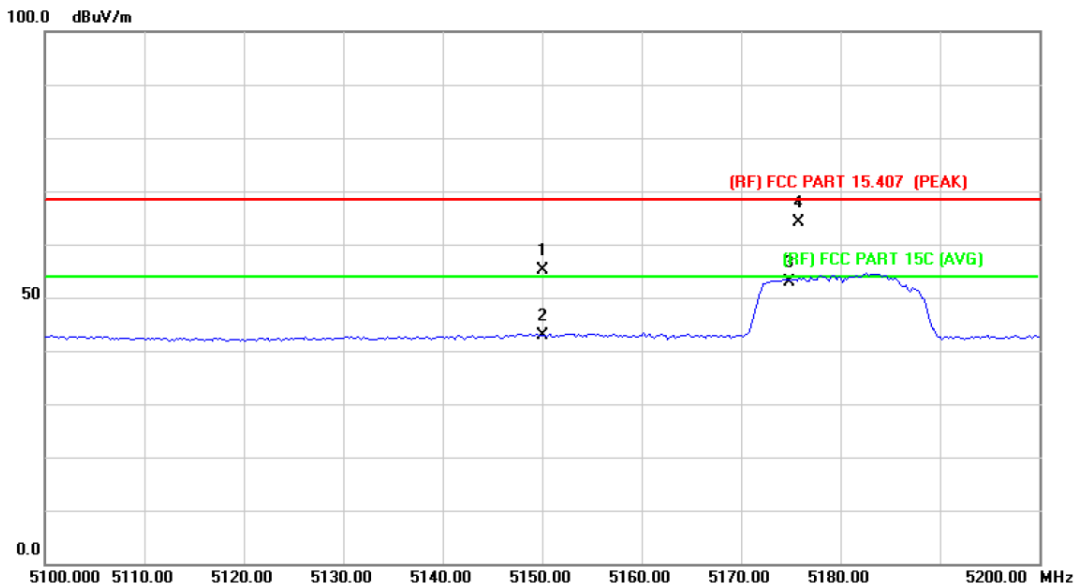

Remark:

1. Corr. = Antenna Factor (dB/m) + Cable Loss (dB)
2. Peak/AVG (dBμV/m)= Corr. (dB/m)+ Read Level (dBμV)
3. Margin (dB) = Peak/AVG (dBμV/m)-Limit PK/AVG(dBμV/m)

Temperature:	25 °C	Relative Humidity:	55%
Test Voltage:	DC 3.8V		
Ant. Pol.	Horizontal		
Test Mode:	TX 802.11a Mode 5240 MHz (U-NII-1)		
Remark:			

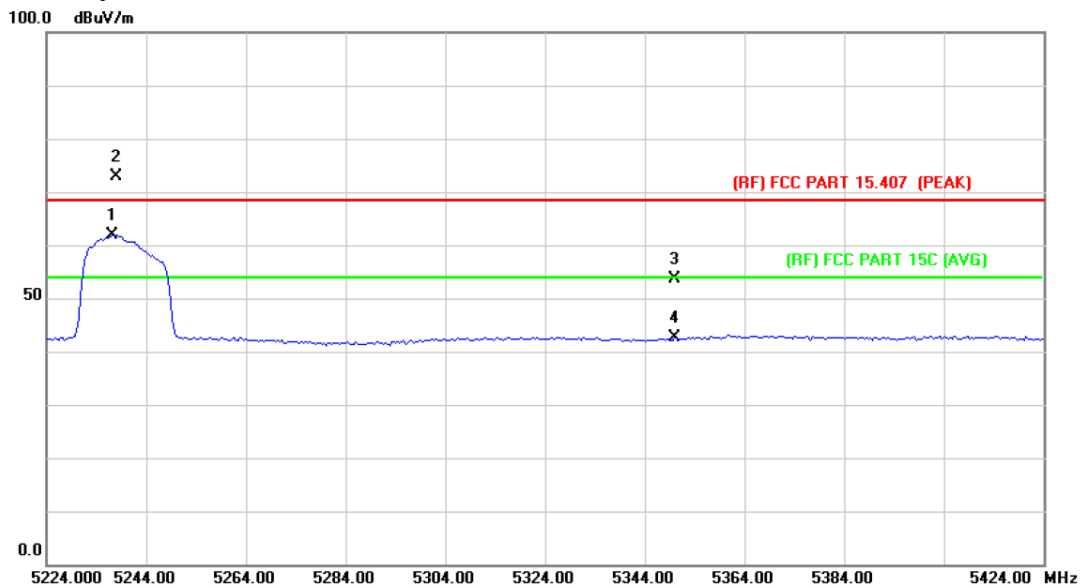

No.	Mk.	Freq. MHz	Reading Level dBuV	Correct Factor dB/m	Measure- ment dBuV/m	Limit dBuV/m	Over dB	Detector
1	*	5237.200	47.00	14.80	61.80	Fundamental Frequency		AVG
2	X	5238.000	58.02	14.79	72.81	Fundamental Frequency		peak
3		5350.000	38.73	14.97	53.70	68.30	-14.60	peak
4		5350.000	27.67	14.97	42.64	54.00	-11.36	AVG

Remark:

1. Corr. = Antenna Factor (dB/m) + Cable Loss (dB)
2. Peak/AVG (dBμV/m)= Corr. (dB/m)+ Read Level (dBμV)
3. Margin (dB) = Peak/AVG (dBμV/m)-Limit PK/AVG(dBμV/m)

Temperature:	25 °C	Relative Humidity:	55%
Test Voltage:	DC 3.8V		
Ant. Pol.	Vertical		
Test Mode:	TX 802.11a Mode 5240 MHz (U-NII-1)		
Remark:			

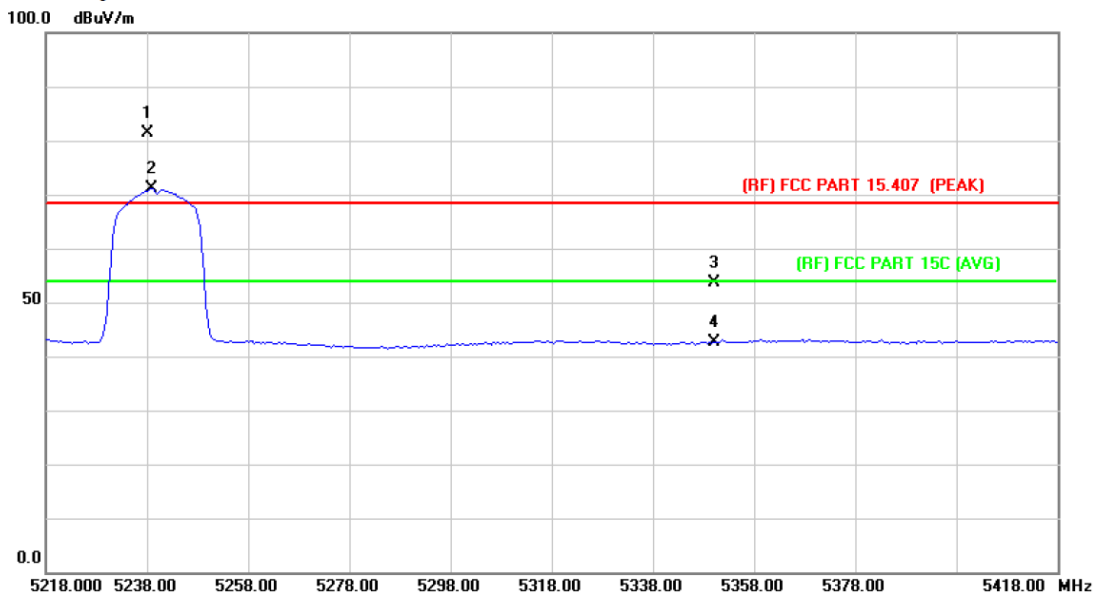

No.	Mk.	Freq. MHz	Reading Level dBuV	Correct Factor dB/m	Measure- ment dBuV/m	Limit dBuV/m	Over dB	Detector
1	X	5238.000	66.59	14.79	81.38	Fundamental Frequency		peak
2	*	5238.800	56.23	14.79	71.02	Fundamental Frequency		AVG
3		5350.000	38.70	14.97	53.67	68.30	-14.63	peak
4		5350.000	27.74	14.97	42.71	54.00	-11.29	AVG

Remark:

1. Corr. = Antenna Factor (dB/m) + Cable Loss (dB)
2. Peak/AVG (dBμV/m)= Corr. (dB/m)+ Read Level (dBμV)
3. Margin (dB) = Peak/AVG (dBμV/m)-Limit PK/AVG(dBμV/m)

Temperature:	25 °C	Relative Humidity:	55%
Test Voltage:	DC 3.8V		
Ant. Pol.	Horizontal		
Test Mode:	TX 802.11n(HT20) Mode 5180 MHz (U-NII-1)		
Remark:			

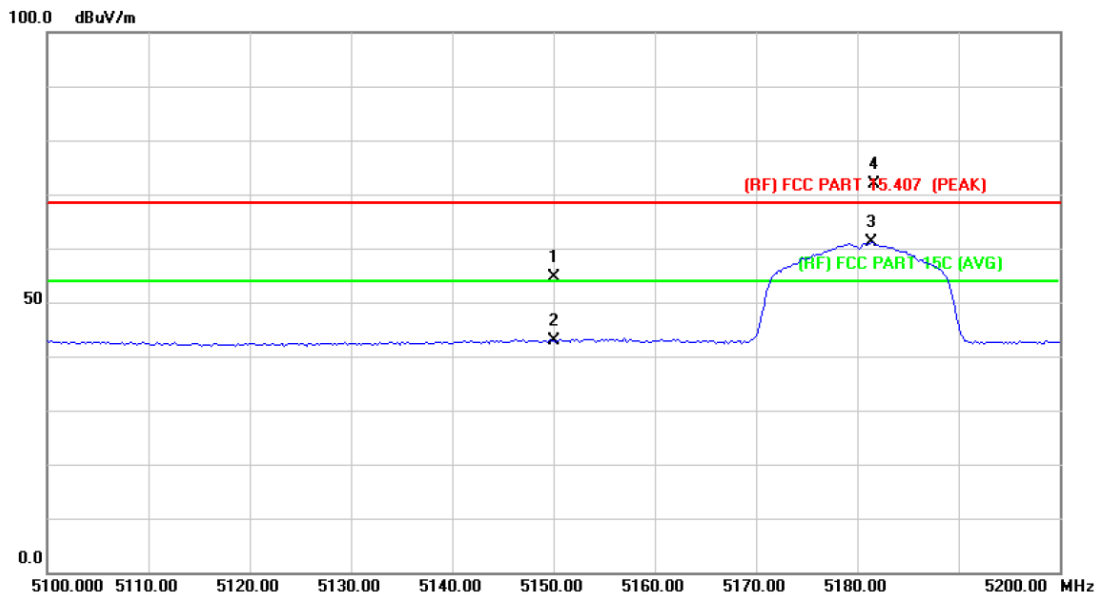

No.	Mk.	Freq. MHz	Reading Level dBuV	Correct Factor dB/m	Measure- ment dBuV/m	Limit dBuV/m	Over dB	Detector
1		5150.000	39.89	14.67	54.56	68.30	-13.74	peak
2		5150.000	28.16	14.67	42.83	54.00	-11.17	AVG
3	*	5181.400	46.44	14.72	61.16	Fundamental Frequency		AVG
4	X	5181.600	57.10	14.72	71.82	Fundamental Frequency		peak

Remark:

1. Corr. = Antenna Factor (dB/m) + Cable Loss (dB)
2. Peak/AVG (dBμV/m)= Corr. (dB/m)+ Read Level (dBμV)
3. Margin (dB) = Peak/AVG (dBμV/m)-Limit PK/AVG(dBμV/m)

Temperature:	25 °C	Relative Humidity:	55%
Test Voltage:	DC 3.8V		
Ant. Pol.	Vertical		
Test Mode:	TX 802.11n(HT20) Mode 5180 MHz (U-NII-1)		
Remark:			

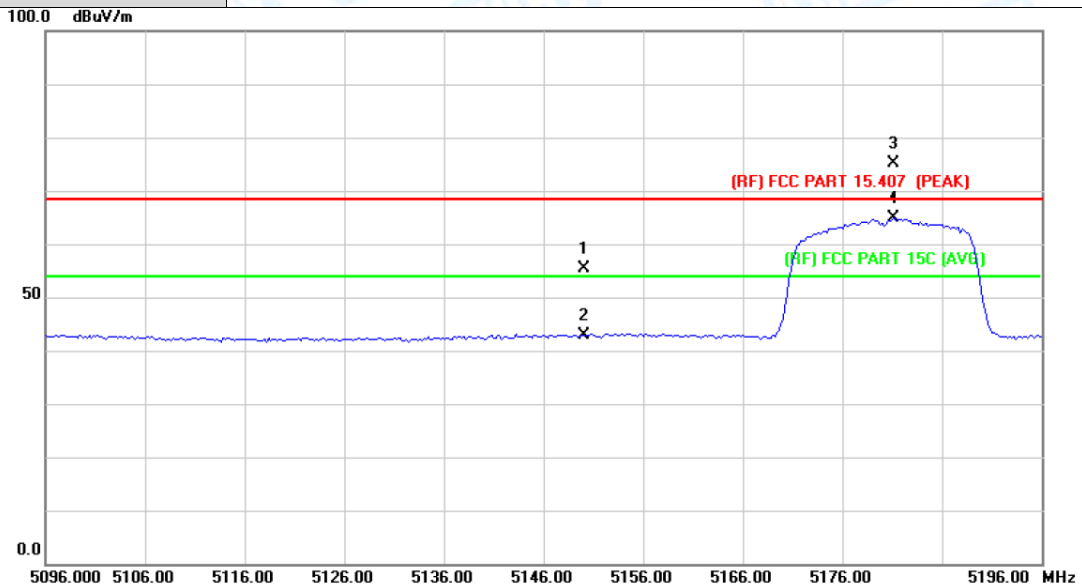

No.	Mk.	Freq. MHz	Reading Level dBuV	Correct Factor dB/m	Measure- ment dBuV/m	Limit dBuV/m	Over dB	Detector
1		5150.000	40.77	14.67	55.44	68.30	-12.86	peak
2		5150.000	28.13	14.67	42.80	54.00	-11.20	AVG
3	X	5181.200	60.39	14.72	75.11	Fundamental Frequency		peak
4	*	5181.200	50.15	14.72	64.87	Fundamental Frequency		AVG

Remark:

1. Corr. = Antenna Factor (dB/m) + Cable Loss (dB)
2. Peak/AVG (dBμV/m) = Corr. (dB/m) + Read Level (dBμV)
3. Margin (dB) = Peak/AVG (dBμV/m) - Limit PK/AVG (dBμV/m)

Temperature:	25 °C	Relative Humidity:	55%
Test Voltage:	DC 3.8V		
Ant. Pol.	Horizontal		
Test Mode:	TX 802.11n(HT20) Mode 5240 MHz (U-NII-1)		
Remark:			

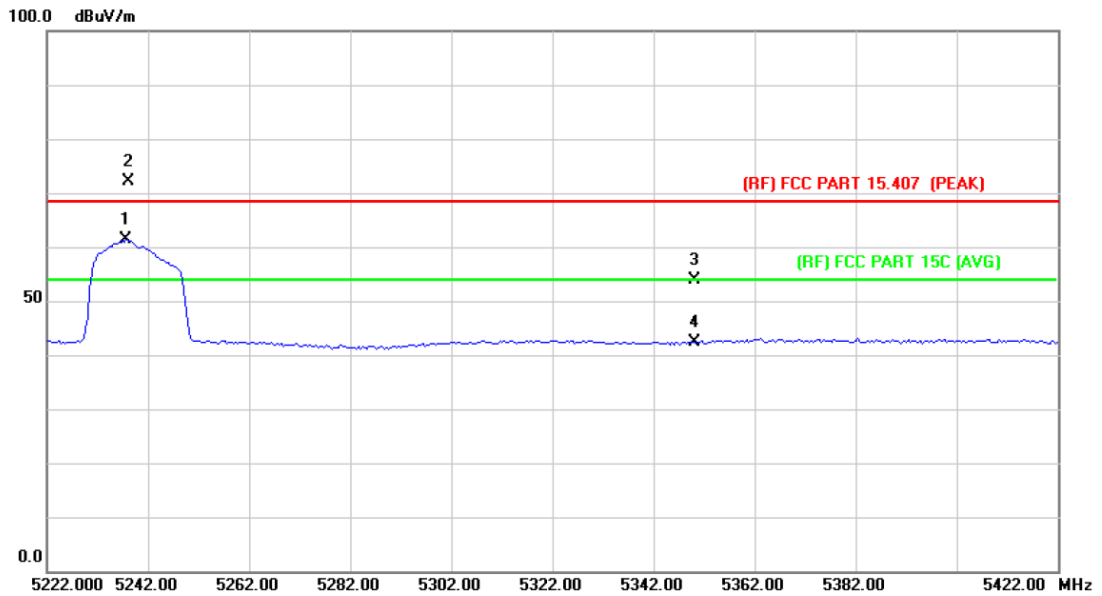

No.	Mk.	Freq. MHz	Reading Level dBuV	Correct Factor dB/m	Measure- ment dBuV/m	Limit dBuV/m	Over dB	Detector
1	*	5237.600	46.49	14.80	61.29	Fundamental Frequency		AVG
2	X	5238.000	57.31	14.79	72.10	Fundamental Frequency		peak
3		5350.000	38.98	14.97	53.95	68.30	-14.35	peak
4		5350.000	27.34	14.97	42.31	54.00	-11.69	AVG

Remark:

1. Corr. = Antenna Factor (dB/m) + Cable Loss (dB)
2. Peak/AVG (dBμV/m)= Corr. (dB/m)+ Read Level (dBμV)
3. Margin (dB) = Peak/AVG (dBμV/m)-Limit PK/AVG(dBμV/m)

Temperature:	25 °C	Relative Humidity:	55%
Test Voltage:	DC 3.8V		
Ant. Pol.	Vertical		
Test Mode:	TX 802.11n(HT20) Mode 5240 MHz (U-NII-1)		
Remark:			

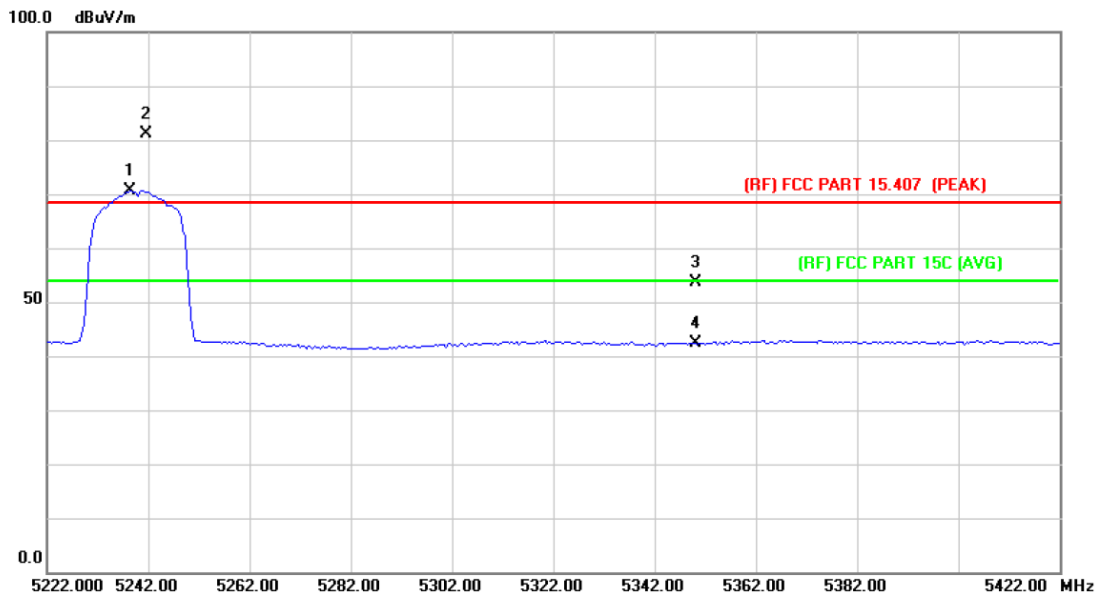

No.	Mk.	Freq. MHz	Reading Level dBuV	Correct Factor dB/m	Measure- ment dBuV/m	Limit dBuV/m	Over dB	Detector
1	*	5238.400	55.89	14.79	70.68	Fundamental Frequency		AVG
2	X	5241.600	66.43	14.81	81.24	Fundamental Frequency		peak
3		5350.000	38.66	14.97	53.63	68.30	-14.67	peak
4		5350.000	27.46	14.97	42.43	54.00	-11.57	AVG

Remark:

1. Corr. = Antenna Factor (dB/m) + Cable Loss (dB)
2. Peak/AVG (dBuV/m) = Corr. (dB/m) + Read Level (dBuV)
3. Margin (dB) = Peak/AVG (dBuV/m) - Limit PK/AVG (dBuV/m)

Temperature:	25 °C	Relative Humidity:	55%
Test Voltage:	DC 3.8V		
Ant. Pol.	Horizontal		
Test Mode:	TX 802.11ac(VHT20) Mode 5180 MHz (U-NII-1)		
Remark:			

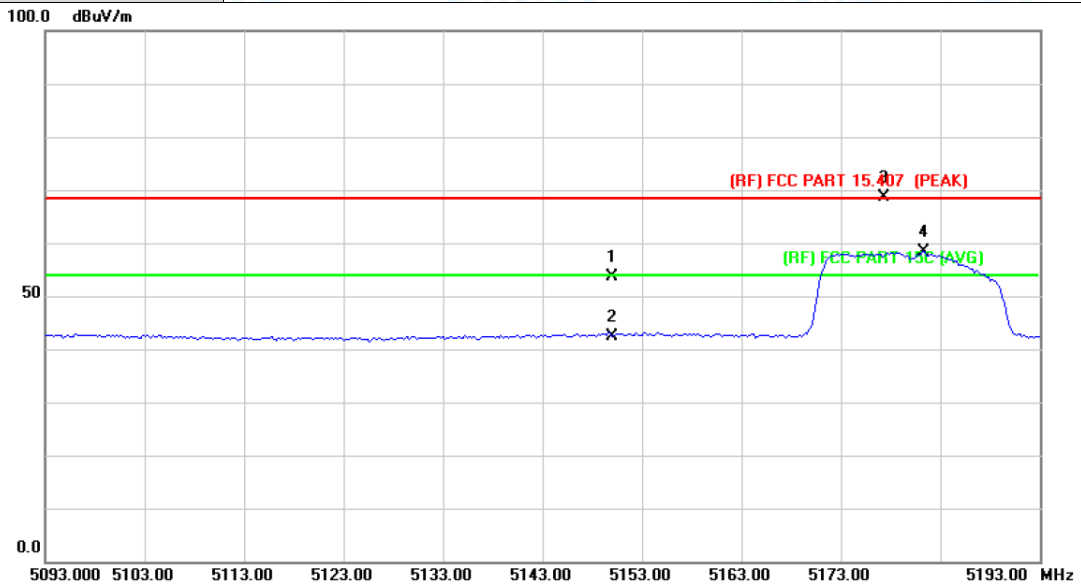

No.	Mk.	Freq. MHz	Reading Level dBuV	Correct Factor dB/m	Measure- ment dBuV/m	Limit dBuV/m	Over dB	Detector
1		5150.000	38.98	14.67	53.65	68.30	-14.65	peak
2		5150.000	27.79	14.67	42.46	54.00	-11.54	AVG
3	X	5177.400	53.93	14.71	68.64	Fundamental Frequency		peak
4	*	5181.400	43.61	14.72	58.33	Fundamental Frequency		AVG

Remark:

1. Corr. = Antenna Factor (dB/m) + Cable Loss (dB)
2. Peak/AVG (dBuV/m) = Corr. (dB/m) + Read Level (dBuV)
3. Margin (dB) = Peak/AVG (dBuV/m) - Limit PK/AVG (dBuV/m)

Temperature:	25 °C	Relative Humidity:	55%
Test Voltage:	DC 3.8V		
Ant. Pol.	Vertical		
Test Mode:	TX 802.11ac(VHT20) Mode 5180 MHz (U-NII-1)		
Remark:			

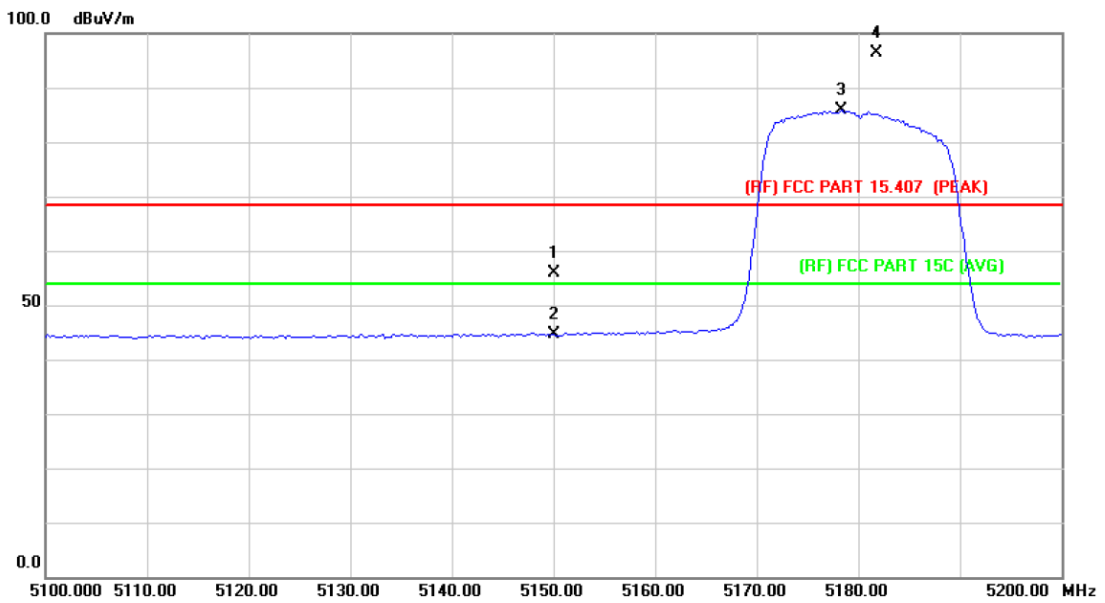

No.	Mk.	Freq. MHz	Reading Level dBuV	Correct Factor dB/m	Measure- ment dBuV/m	Limit dBuV/m	Over dB	Detector
1		5150.000	38.98	14.67	53.65	68.30	-14.65	peak
2		5150.000	27.79	14.67	42.46	54.00	-11.54	AVG
3	X	5177.400	53.93	14.71	68.64	Fundamental Frequency		peak
4	*	5181.400	43.61	14.72	58.33	Fundamental Frequency		AVG

Remark:

1. Corr. = Antenna Factor (dB/m) + Cable Loss (dB)
2. Peak/AVG (dBμV/m) = Corr. (dB/m) + Read Level (dBμV)
3. Margin (dB) = Peak/AVG (dBμV/m) - Limit PK/AVG (dBμV/m)

Temperature:	25 °C	Relative Humidity:	55%
Test Voltage:	DC 3.8V		
Ant. Pol.	Horizontal		
Test Mode:	TX 802.11ac(VHT20) Mode 5240 MHz (U-NII-1)		
Remark:			

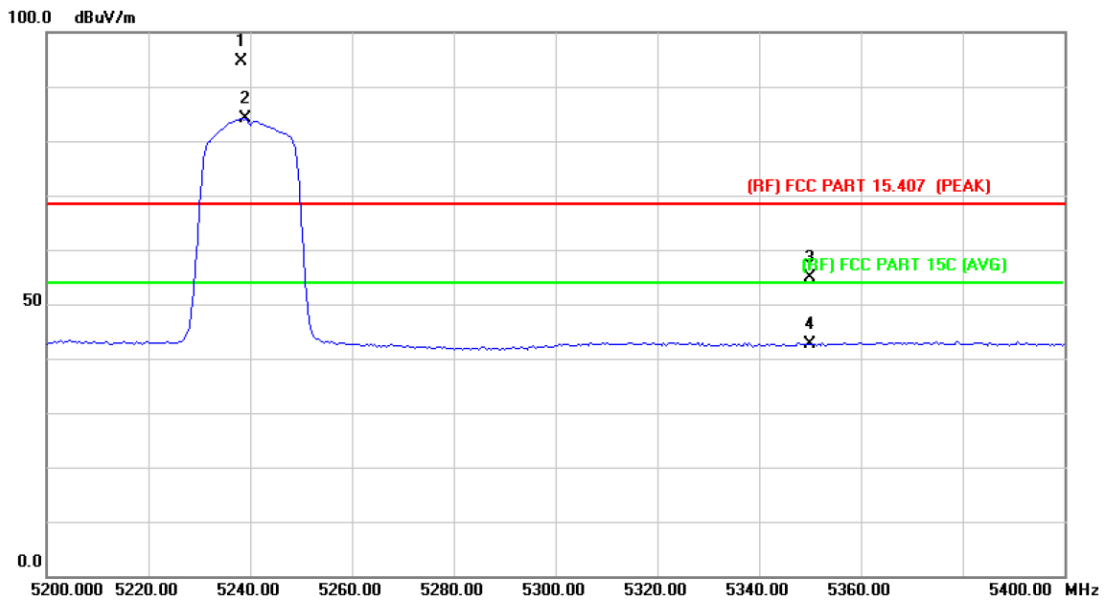

No.	Mk.	Freq. MHz	Reading Level dBuV	Correct Factor dB/m	Measure- ment dBuV/m	Limit dBuV/m	Over dB	Detector
1	X	5238.400	79.87	14.79	94.66			peak
2	*	5239.200	69.39	14.79	84.18			AVG
3		5350.000	39.95	14.97	54.92	68.30	-13.38	peak
4		5350.000	27.58	14.97	42.55	54.00	-11.45	AVG

Remark:

1. Corr. = Antenna Factor (dB/m) + Cable Loss (dB)
2. Peak/AVG (dBμV/m)= Corr. (dB/m)+ Read Level (dBμV)
3. Margin (dB) = Peak/AVG (dBμV/m)-Limit PK/AVG(dBμV/m)

Temperature:	25 °C	Relative Humidity:	55%
Test Voltage:	DC 3.8V		
Ant. Pol.	Vertical		
Test Mode:	TX 802.11ac(VHT20) Mode 5240 MHz (U-NII-1)		
Remark:			

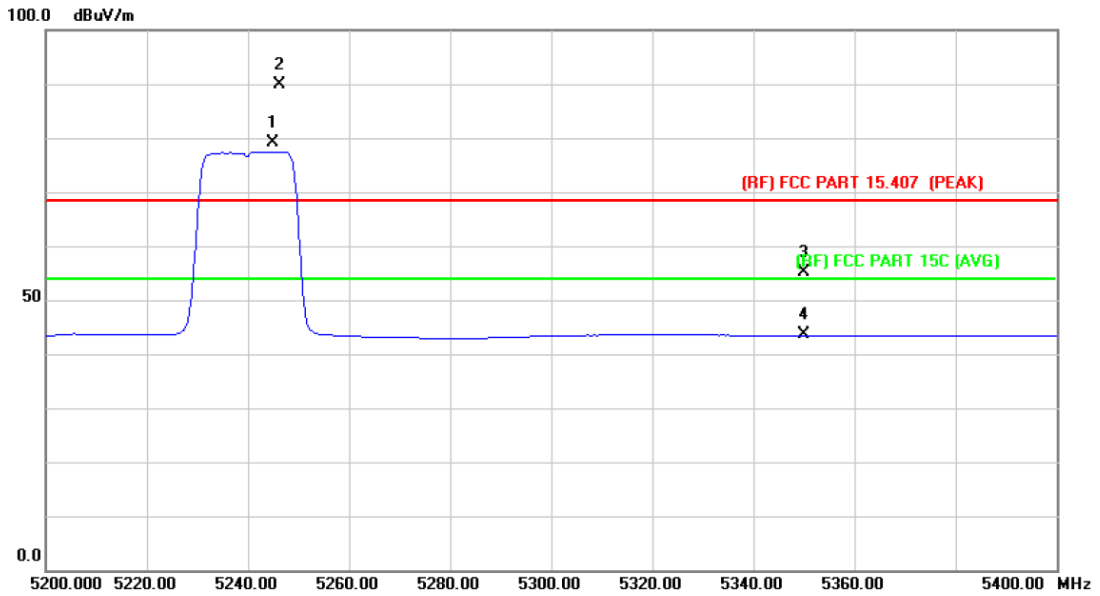

No.	Mk.	Freq. MHz	Reading Level dBuV	Correct Factor dB/m	Measure- ment dBuV/m	Limit dBuV/m	Over dB	Detector
1	*	5244.800	64.22	14.81	79.03	Fundamental Frequency		AVG
2	X	5246.400	75.03	14.81	89.84	Fundamental Frequency		peak
3		5350.000	40.13	14.97	55.10	68.30	-13.20	peak
4		5350.000	28.71	14.97	43.68	54.00	-10.32	AVG

Remark:

1. Corr. = Antenna Factor (dB/m) + Cable Loss (dB)
2. Peak/AVG (dBμV/m)= Corr. (dB/m)+ Read Level (dBμV)
3. Margin (dB) = Peak/AVG (dBμV/m)-Limit PK/AVG(dBμV/m)

Temperature:	25 °C	Relative Humidity:	55%
Test Voltage:	DC 3.8V		
Ant. Pol.	Horizontal		
Test Mode:	TX 802.11n(HT40) Mode 5190 MHz (U-NII-1)		
Remark:			

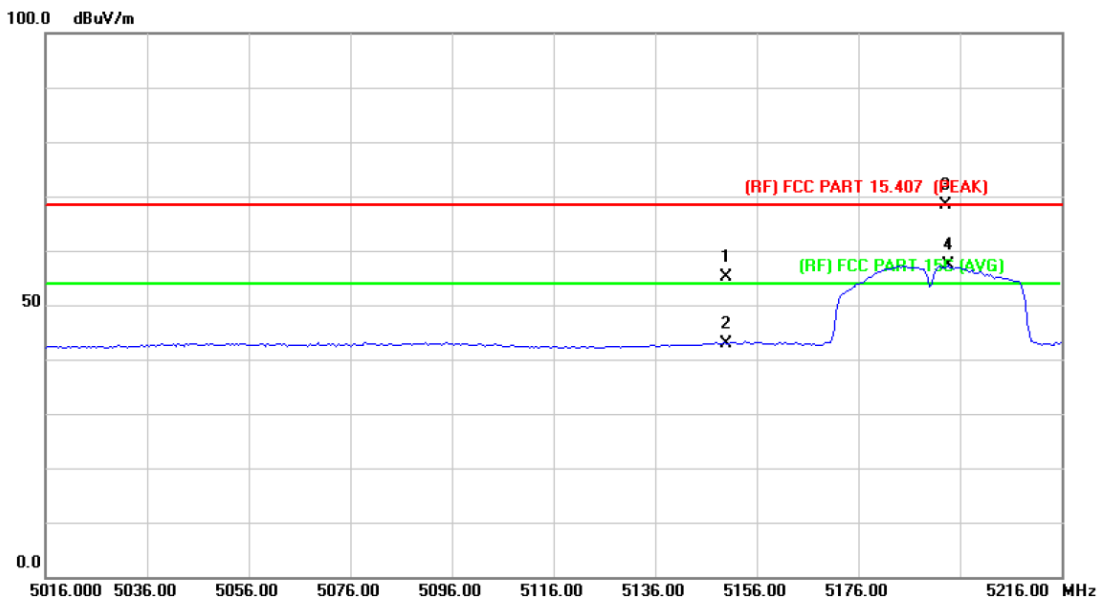

No.	Mk.	Freq. MHz	Reading Level dBuV	Correct Factor dB/m	Measure- ment dBuV/m	Limit dBuV/m	Over dB	Detector
1		5150.000	40.35	14.67	55.02	68.30	-13.28	peak
2		5150.000	28.20	14.67	42.87	54.00	-11.13	AVG
3	X	5193.200	53.59	14.73	68.32	Fundamental Frequency		peak
4	*	5193.600	42.56	14.73	57.29	Fundamental Frequency		AVG

Remark:

1. Corr. = Antenna Factor (dB/m) + Cable Loss (dB)
2. Peak/AVG (dBμV/m)= Corr. (dB/m)+ Read Level (dBμV)
3. Margin (dB) = Peak/AVG (dBμV/m)-Limit PK/AVG(dBμV/m)

Temperature:	25 °C	Relative Humidity:	55%
Test Voltage:	DC 3.8V		
Ant. Pol.	Vertical		
Test Mode:	TX 802.11n(HT40) Mode 5190 MHz (U-NII-1)		
Remark:			

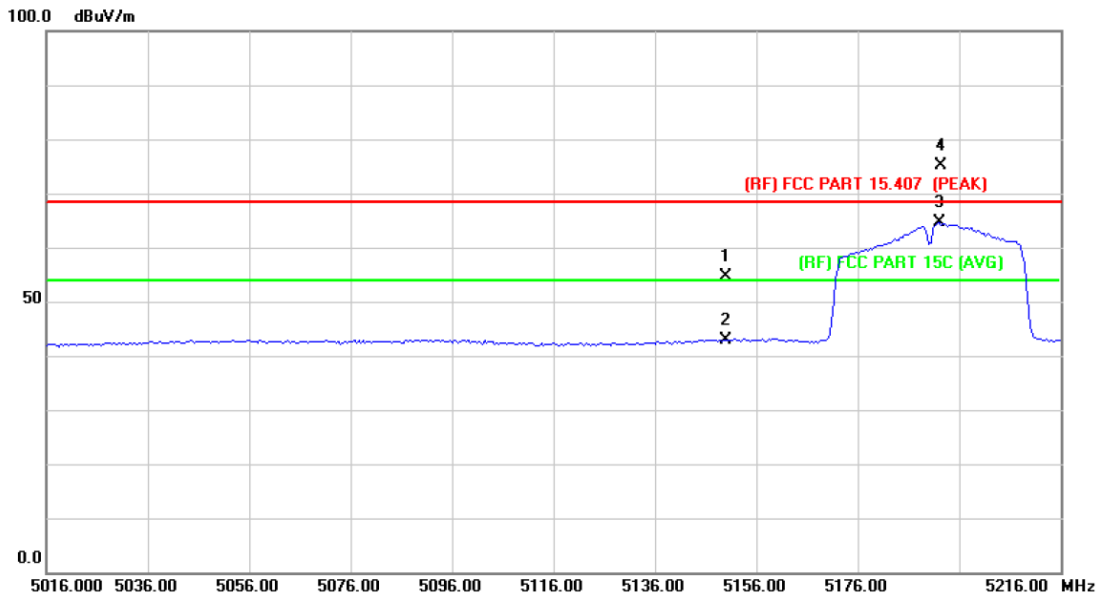

No.	Mk.	Freq. MHz	Reading Level dBuV	Correct Factor dB/m	Measure- ment dBuV/m	Limit dBuV/m	Over dB	Detector
1		5150.000	39.98	14.67	54.65	68.30	-13.65	peak
2		5150.000	28.14	14.67	42.81	54.00	-11.19	AVG
3	*	5192.000	49.92	14.73	64.65	-----	-----	AVG
4	X	5192.400	60.41	14.73	75.14	-----	-----	peak

Remark:

1. Corr. = Antenna Factor (dB/m) + Cable Loss (dB)
2. Peak/AVG (dBuV/m) = Corr. (dB/m) + Read Level (dBuV)
3. Margin (dB) = Peak/AVG (dBuV/m) - Limit PK/AVG (dBuV/m)

Temperature:	25 °C	Relative Humidity:	55%
Test Voltage:	DC 3.8V		
Ant. Pol.	Horizontal		
Test Mode:	TX 802.11n(HT40) Mode 5230 MHz (U-NII-1)		
Remark:			

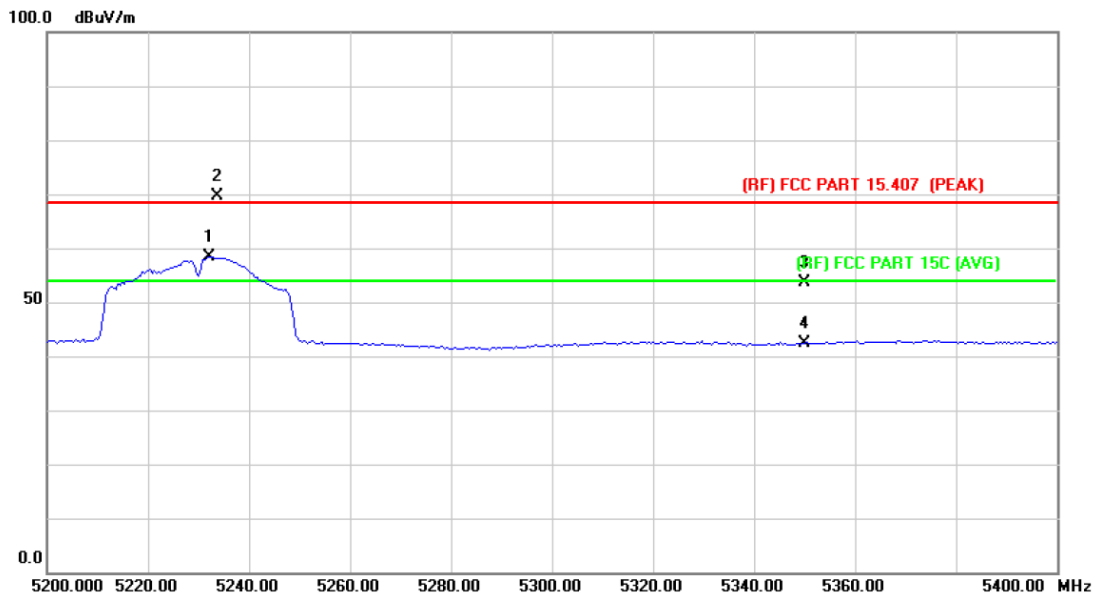

No.	Mk.	Freq. MHz	Reading Level dBuV	Correct Factor dB/m	Measure- ment dBuV/m	Limit dBuV/m	Over dB	Detector
1	*	5232.000	43.64	14.79	58.43	Fundamental Frequency		AVG
2	X	5233.600	54.88	14.80	69.68	Fundamental Frequency		peak
3		5350.000	38.75	14.97	53.72	68.30	-14.58	peak
4		5350.000	27.29	14.97	42.26	54.00	-11.74	AVG

Remark:

1. Corr. = Antenna Factor (dB/m) + Cable Loss (dB)
2. Peak/AVG (dBμV/m)= Corr. (dB/m)+ Read Level (dBμV)
3. Margin (dB) = Peak/AVG (dBμV/m)-Limit PK/AVG(dBμV/m)

Temperature:	25 °C	Relative Humidity:	55%
Test Voltage:	DC 3.8V		
Ant. Pol.	Vertical		
Test Mode:	TX 802.11n(HT40) Mode 5230 MHz (U-NII-1)		
Remark:			

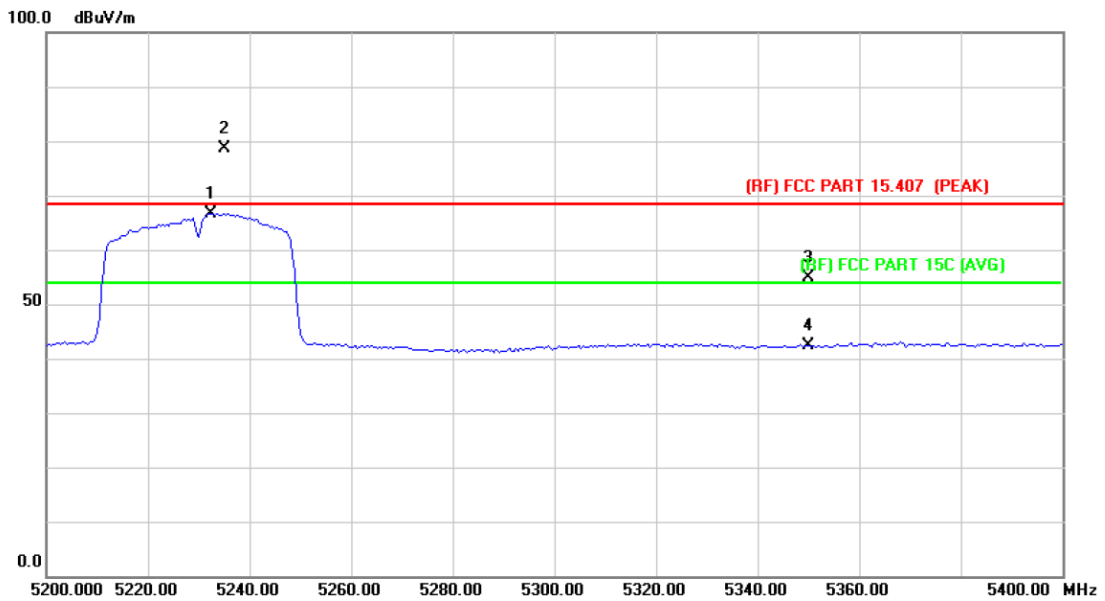

No.	Mk.	Freq. MHz	Reading Level dBuV	Correct Factor dB/m	Measure- ment dBuV/m	Limit dBuV/m	Over dB	Detector
1	*	5232.400	51.87	14.80	66.67	Fundamental Frequency		AVG
2	X	5235.200	63.72	14.80	78.52	Fundamental Frequency		peak
3		5350.000	39.83	14.97	54.80	68.30	-13.50	peak
4		5350.000	27.39	14.97	42.36	54.00	-11.64	AVG

Remark:

1. Corr. = Antenna Factor (dB/m) + Cable Loss (dB)
2. Peak/AVG (dBμV/m) = Corr. (dB/m) + Read Level (dBμV)
3. Margin (dB) = Peak/AVG (dBμV/m) - Limit PK/AVG (dBμV/m)

Temperature:	25 °C	Relative Humidity:	55%
Test Voltage:	DC 3.8V		
Ant. Pol.	Horizontal		
Test Mode:	TX 802.11ac(VHT40) Mode 5190 MHz (U-NII-1)		
Remark:			

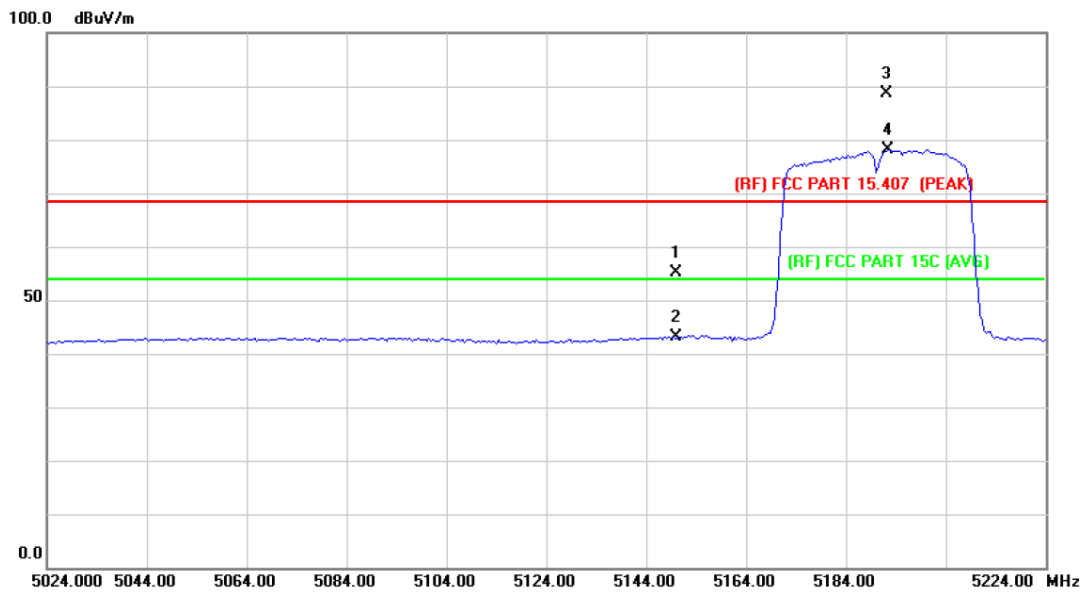

No.	Mk.	Freq. MHz	Reading Level dBuV	Correct Factor dB/m	Measure- ment dBuV/m	Limit dBuV/m	Over dB	Detector
1	X	5150.000	40.55	14.67	55.22	54.00	1.22	AVG
2		5150.000	28.50	14.67	43.17	54.00	-10.83	AVG
3	X	5192.000	73.95	14.73	88.68	Fundamental Frequency		peak
4	*	5192.400	63.42	14.73	78.15	Fundamental Frequency		AVG

Remark:

1. Corr. = Antenna Factor (dB/m) + Cable Loss (dB)
2. Peak/AVG (dBuV/m) = Corr. (dB/m) + Read Level (dBuV)
3. Margin (dB) = Peak/AVG (dBuV/m) - Limit PK/AVG (dBuV/m)

Temperature:	25 °C	Relative Humidity:	55%
Test Voltage:	DC 3.8V		
Ant. Pol.	Vertical		
Test Mode:	TX 802.11ac(VHT40) Mode 5190 MHz (U-NII-1)		
Remark:			

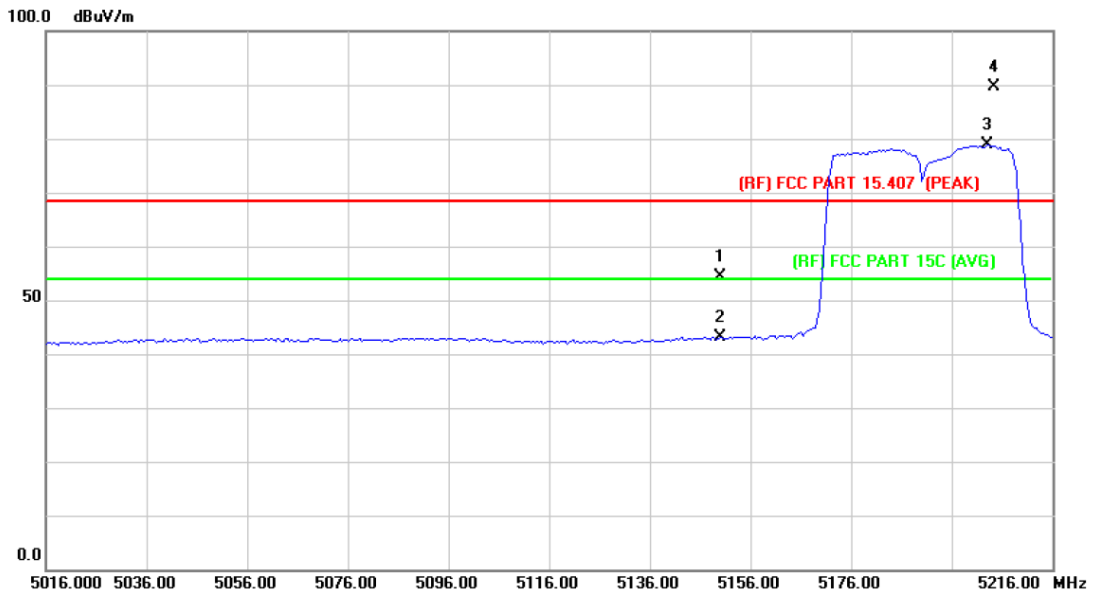

No.	Mk.	Freq. MHz	Reading Level dBuV	Correct Factor dB/m	Measure- ment dBuV/m	Limit dBuV/m	Over dB	Detector
1		5150.000	39.67	14.67	54.34	68.30	-13.96	peak
2		5150.000	28.38	14.67	43.05	54.00	-10.95	AVG
3	*	5203.200	64.06	14.75	78.81	Fundamental Frequency		AVG
4	X	5204.400	74.88	14.76	89.64	Fundamental Frequency		peak

Remark:

1. Corr. = Antenna Factor (dB/m) + Cable Loss (dB)
2. Peak/AVG (dBuV/m) = Corr. (dB/m) + Read Level (dBuV)
3. Margin (dB) = Peak/AVG (dBuV/m) - Limit PK/AVG (dBuV/m)

Temperature:	25 °C	Relative Humidity:	55%
Test Voltage:	DC 3.8V		
Ant. Pol.	Horizontal		
Test Mode:	TX 802.11ac(VHT40) Mode 5230 MHz (U-NII-1)		
Remark:			

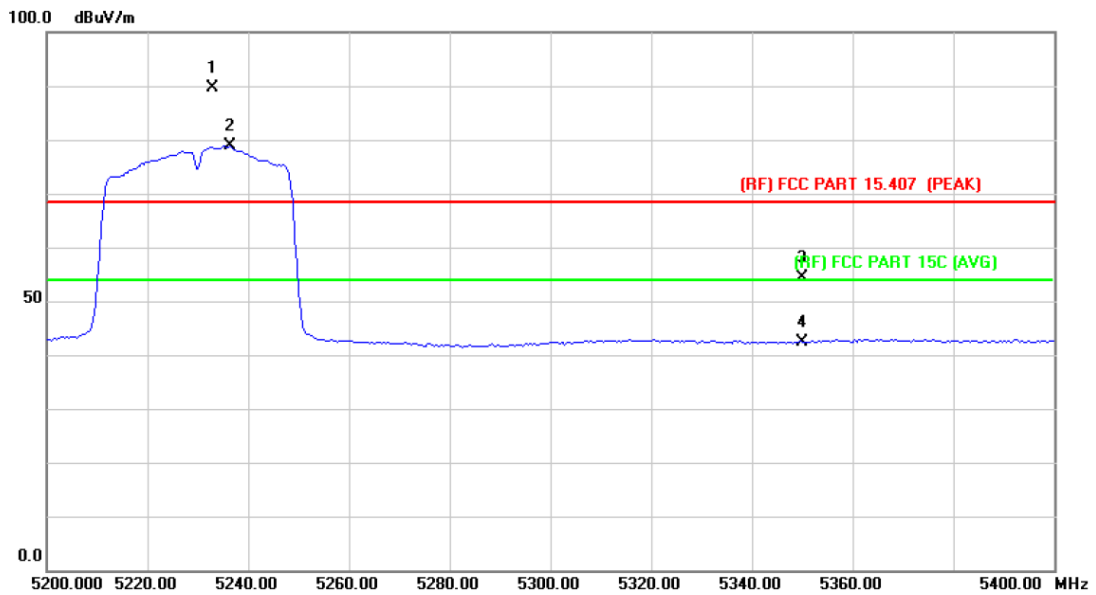

No.	Mk.	Freq. MHz	Reading Level dBuV	Correct Factor dB/m	Measure- ment dBuV/m	Limit dBuV/m	Over dB	Detector
1	X	5232.800	74.82	14.80	89.62	Fundamental Frequency		peak
2	*	5236.400	64.04	14.80	78.84	Fundamental Frequency		AVG
3		5350.000	39.32	14.97	54.29	68.30	-14.01	peak
4		5350.000	27.37	14.97	42.34	54.00	-11.66	AVG

Remark:

1. Corr. = Antenna Factor (dB/m) + Cable Loss (dB)
2. Peak/AVG (dBμV/m) = Corr. (dB/m) + Read Level (dBμV)
3. Margin (dB) = Peak/AVG (dBμV/m) - Limit PK/AVG (dBμV/m)

Temperature:	25 °C	Relative Humidity:	55%
Test Voltage:	DC 3.8V		
Ant. Pol.	Vertical		
Test Mode:	TX 802.11ac(VHT40) Mode 5230 MHz (U-NII-1)		
Remark:			

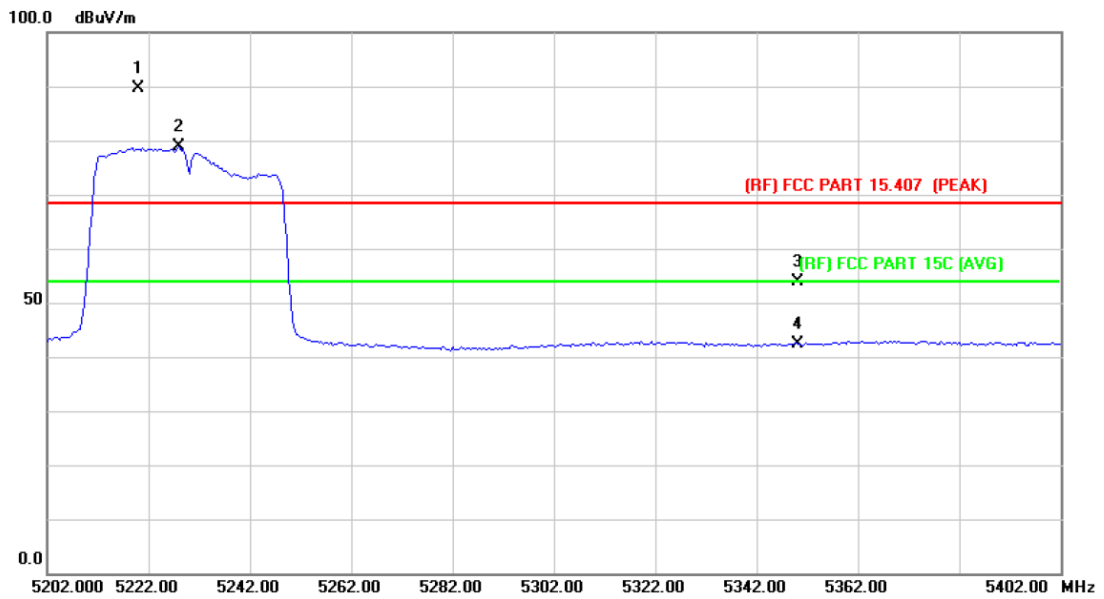

No.	Mk.	Freq. MHz	Reading Level dBuV	Correct Factor dB/m	Measure- ment dBuV/m	Limit dBuV/m	Over dB	Detector
1	X	5220.000	74.80	14.78	89.58	Fundamental Frequency		peak
2	*	5228.000	64.16	14.79	78.95	Fundamental Frequency		AVG
3		5350.000	38.81	14.97	53.78	68.30	-14.52	peak
4		5350.000	27.49	14.97	42.46	54.00	-11.54	AVG

Remark:

1. Corr. = Antenna Factor (dB/m) + Cable Loss (dB)
2. Peak/AVG (dBμV/m)= Corr. (dB/m)+ Read Level (dBμV)
3. Margin (dB) = Peak/AVG (dBμV/m)-Limit PK/AVG(dBμV/m)

Temperature:	25 °C	Relative Humidity:	55%
Test Voltage:	DC 3.8V		
Ant. Pol.	Horizontal		
Test Mode:	TX 802.11ac(VHT80) Mode 5210 MHz (U-NII-1)		
Remark:			

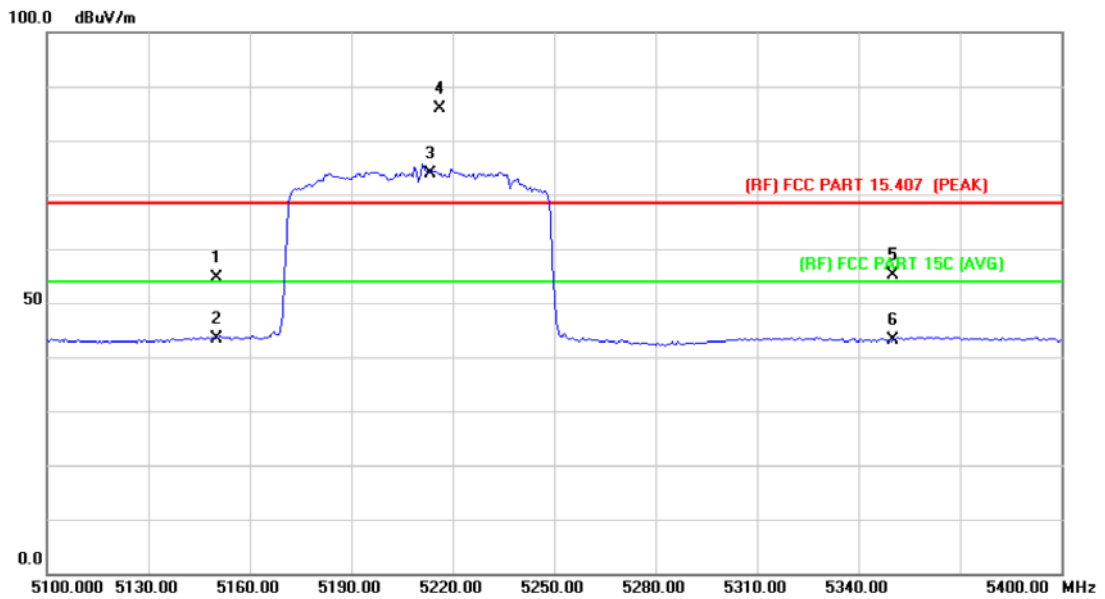

No.	Mk.	Freq. MHz	Reading Level dBuV	Correct Factor dB/m	Measure- ment dBuV/m	Limit dBuV/m	Over dB	Detector
1		5150.000	39.97	14.67	54.64	68.30	-13.66	peak
2		5150.000	28.72	14.67	43.39	54.00	-10.61	AVG
3	*	5213.400	59.03	14.76	73.79	Fundamental Frequency		AVG
4	X	5216.400	71.08	14.76	85.84	Fundamental Frequency		peak
5		5350.000	40.15	14.97	55.12	68.30	-13.18	peak
6		5350.000	28.27	14.97	43.24	54.00	-10.76	AVG

Remark:

1. Corr. = Antenna Factor (dB/m) + Cable Loss (dB)
2. Peak/AVG (dBμV/m)= Corr. (dB/m)+ Read Level (dBμV)
3. Margin (dB) = Peak/AVG (dBμV/m)-Limit PK/AVG(dBμV/m)

Temperature:	25 °C	Relative Humidity:	55%
Test Voltage:	DC 3.8V		
Ant. Pol.	Vertical		
Test Mode:	TX 802.11ac(VHT80) Mode 5210 MHz (U-NII-1)		
Remark:			

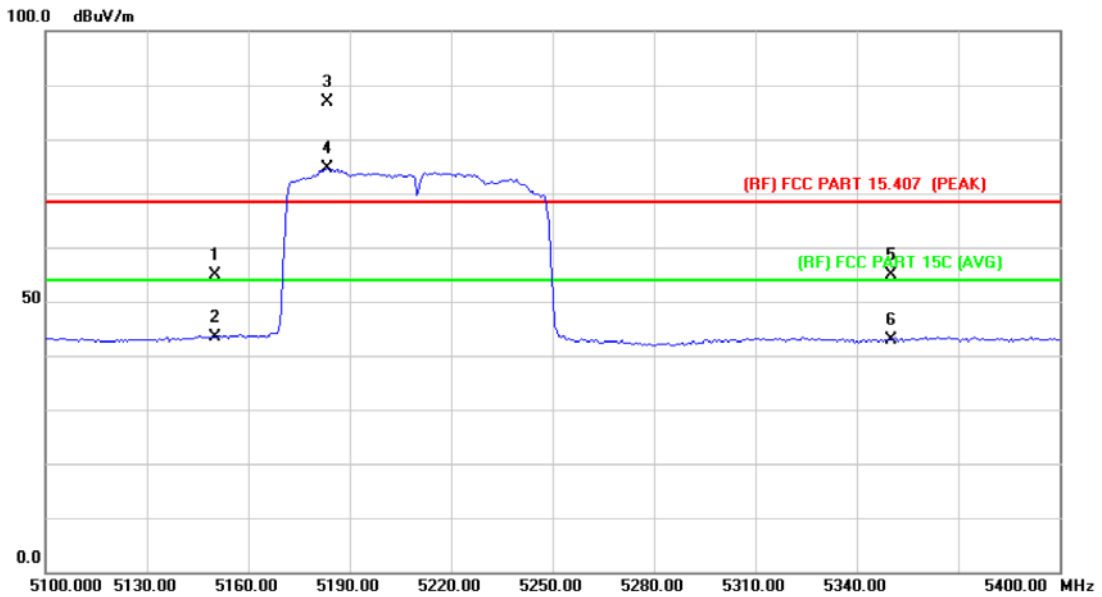

No.	Mk.	Freq. MHz	Reading Level dBuV	Correct Factor dB/m	Measure- ment dBuV/m	Limit dBuV/m	Over dB	Detector
1		5150.000	40.23	14.67	54.90	68.30	-13.40	peak
2		5150.000	28.80	14.67	43.47	54.00	-10.53	AVG
3	X	5183.400	72.24	14.73	86.97	Fundamental Frequency		peak
4	*	5183.400	59.82	14.73	74.55	Fundamental Frequency		AVG
5		5350.000	40.00	14.97	54.97	68.30	-13.33	peak
6		5350.000	28.01	14.97	42.98	54.00	-11.02	AVG

Remark:

1. Corr. = Antenna Factor (dB/m) + Cable Loss (dB)
2. Peak/AVG (dBμV/m) = Corr. (dB/m) + Read Level (dBμV)
3. Margin (dB) = Peak/AVG (dBμV/m) - Limit PK/AVG (dBμV/m)

Temperature:	25 °C	Relative Humidity:	55%
Test Voltage:	DC 3.8V		
Ant. Pol.	Horizontal		
Test Mode:	TX 802.11a Mode 5260 MHz (U-NII-2A)		
Remark:			

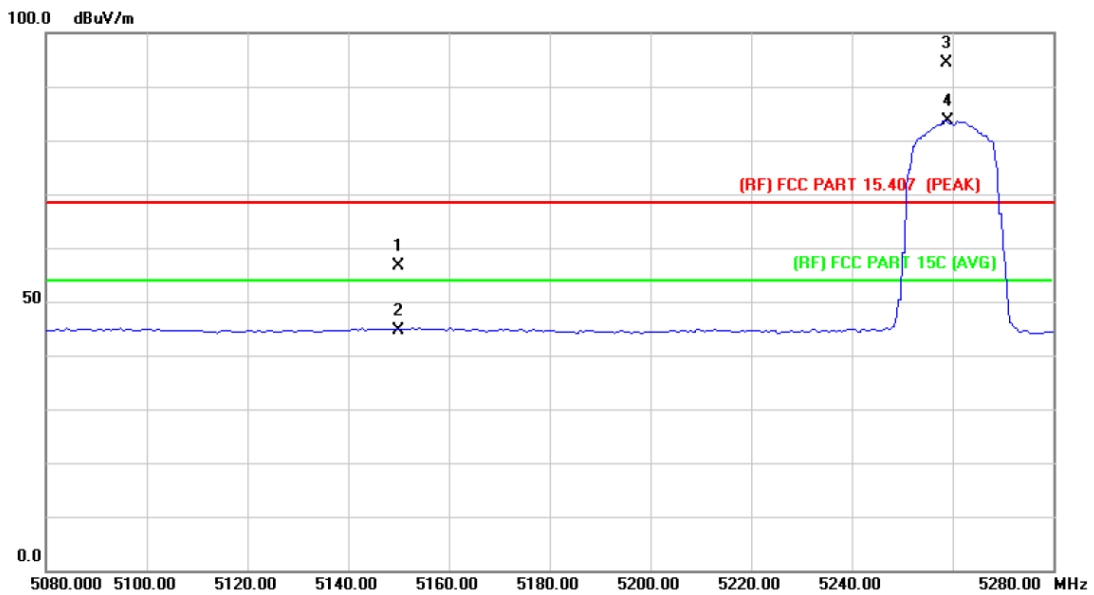

No.	Mk.	Freq. MHz	Reading Level dBuV	Correct Factor dB/m	Measure- ment dBuV/m	Limit dBuV/m	Over dB	Detector
1		5150.000	41.95	14.67	56.62	68.30	-11.68	peak
2		5150.000	30.05	14.67	44.72	54.00	-9.28	AVG
3	X	5258.800	79.45	14.83	94.28	Fundamental Frequency		peak
4	*	5259.200	68.86	14.83	83.69	Fundamental Frequency		AVG

Remark:

1. Corr. = Antenna Factor (dB/m) + Cable Loss (dB)
2. Peak/AVG (dBuV/m) = Corr. (dB/m) + Read Level (dBuV)
3. Margin (dB) = Peak/AVG (dBuV/m) - Limit PK/AVG (dBuV/m)

Temperature:	25 °C	Relative Humidity:	55%
Test Voltage:	DC 3.8V		
Ant. Pol.	Vertical		
Test Mode:	TX 802.11a Mode 5260 MHz (U-NII-2A)		
Remark:			

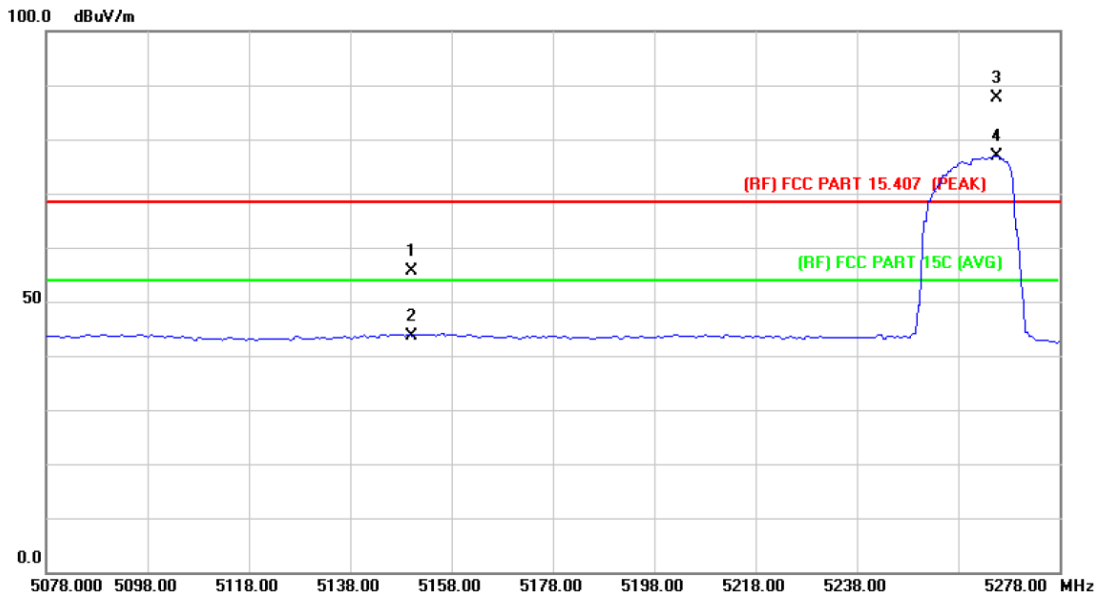

No.	Mk.	Freq. MHz	Reading Level dBuV	Correct Factor dB/m	Measure- ment dBuV/m	Limit dBuV/m	Over dB	Detector
1		5150.000	40.89	14.67	55.56	68.30	-12.74	peak
2		5150.000	28.91	14.67	43.58	54.00	-10.42	AVG
3	X	5265.600	72.67	14.84	87.51	Fundamental Frequency		peak
4	*	5265.600	61.99	14.84	76.83	Fundamental Frequency		AVG

Remark:

1. Corr. = Antenna Factor (dB/m) + Cable Loss (dB)
2. Peak/AVG (dBuV/m) = Corr. (dB/m) + Read Level (dBuV)
3. Margin (dB) = Peak/AVG (dBuV/m) - Limit PK/AVG (dBuV/m)

Temperature:	25 °C	Relative Humidity:	55%
Test Voltage:	DC 3.8V		
Ant. Pol.	Horizontal		
Test Mode:	TX 802.11a Mode 5320 MHz (U-NII-2A)		
Remark:			

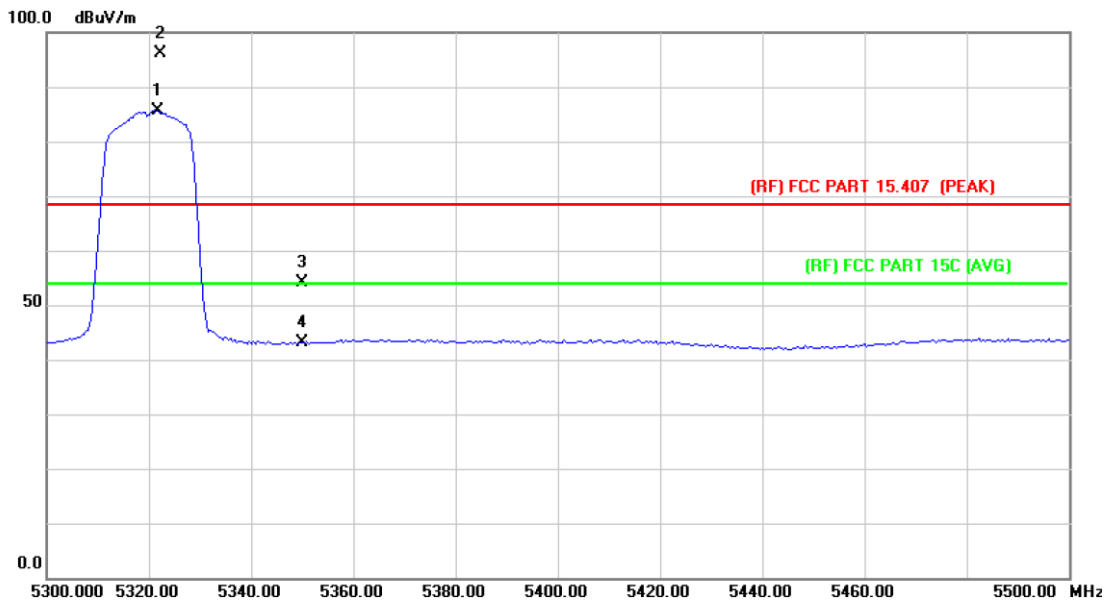

No.	Mk.	Freq. MHz	Reading Level dBuV	Correct Factor dB/m	Measure- ment dBuV/m	Limit dBuV/m	Over dB	Detector
1	*	5321.600	70.65	14.92	85.57	Fundamental Frequency		AVG
2	X	5322.400	81.29	14.92	96.21	Fundamental Frequency		peak
3		5350.000	39.13	14.97	54.10	68.30	-14.20	peak
4		5350.000	28.08	14.97	43.05	54.00	-10.95	AVG

Remark:

1. Corr. = Antenna Factor (dB/m) + Cable Loss (dB)
2. Peak/AVG (dBμV/m)= Corr. (dB/m)+ Read Level (dBμV)
3. Margin (dB) = Peak/AVG (dBμV/m)-Limit PK/AVG(dBμV/m)

Temperature:	25 °C	Relative Humidity:	55%
Test Voltage:	DC 3.8V		
Ant. Pol.	Vertical		
Test Mode:	TX 802.11a Mode 5320 MHz (U-NII-2A)		
Remark:			

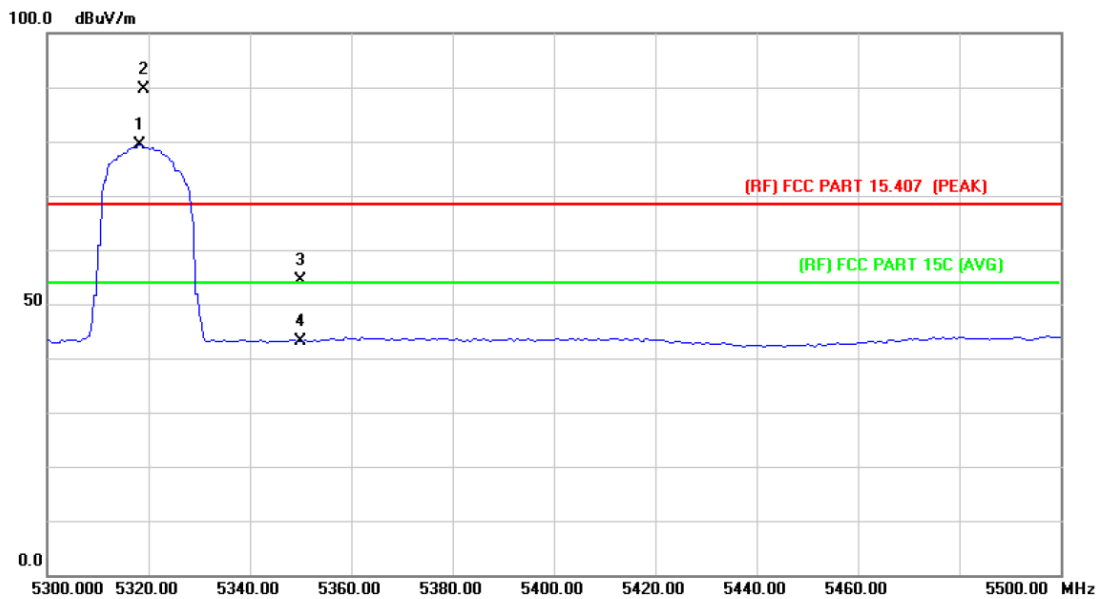

No.	Mk.	Freq. MHz	Reading Level dBuV	Correct Factor dB/m	Measure- ment dBuV/m	Limit dBuV/m	Over dB	Detecto
1	*	5318.400	64.51	14.92	79.43	Fundamental Frequency		AVG
2	X	5319.200	74.59	14.92	89.51	Fundamental Frequency		peak
3		5350.000	39.35	14.97	54.32	68.30	-13.98	peak
4		5350.000	28.11	14.97	43.08	54.00	-10.92	AVG

Remark:

1. Corr. = Antenna Factor (dB/m) + Cable Loss (dB)
2. Peak/AVG (dBμV/m)= Corr. (dB/m)+ Read Level (dBμV)
3. Margin (dB) = Peak/AVG (dBμV/m)-Limit PK/AVG(dBμV/m)

Temperature:	25 °C	Relative Humidity:	55%
Test Voltage:	DC 3.8V		
Ant. Pol.	Horizontal		
Test Mode:	TX 802.11n(HT20) Mode 5260 MHz (U-NII-2A)		
Remark:			

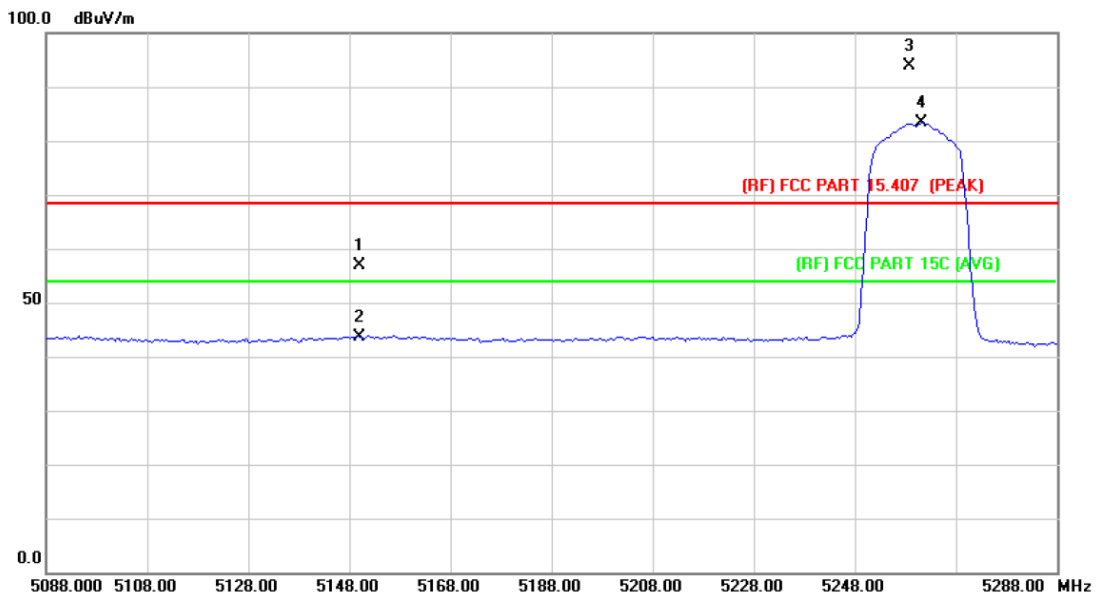

No.	Mk.	Freq. MHz	Reading Level dBuV	Correct Factor dB/m	Measure- ment dBuV/m	Limit dBuV/m	Over dB	Detector
1		5150.000	41.59	13.54	55.13	68.30	-13.17	peak
2		5150.000	32.22	13.54	45.76	54.00	-8.24	AVG
3	X	5258.240	77.79	13.46	91.25	Fundamental Frequency		peak
4	*	5261.600	71.40	13.47	84.87	Fundamental Frequency		AVG

Remark:

1. Corr. = Antenna Factor (dB/m) + Cable Loss (dB)
2. Peak/AVG (dBuV/m) = Corr. (dB/m) + Read Level (dBuV)
3. Margin (dB) = Peak/AVG (dBuV/m) - Limit PK/AVG (dBuV/m)

Temperature:	25 °C	Relative Humidity:	55%
Test Voltage:	DC 3.8V		
Ant. Pol.	Vertical		
Test Mode:	TX 802.11n(HT20) Mode 5260 MHz (U-NII-2A)		
Remark:			

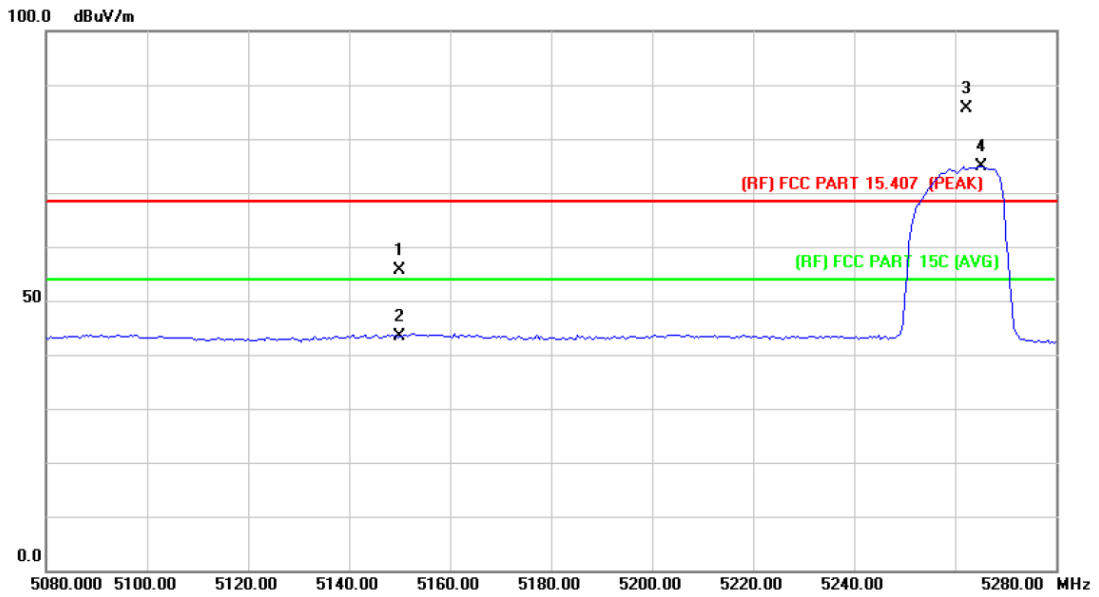

No.	Mk.	Freq. MHz	Reading Level dBuV	Correct Factor dB/m	Measure- ment dBuV/m	Limit dBuV/m	Over dB	Detector
1		5150.000	40.89	14.67	55.56	68.30	-12.74	peak
2		5150.000	28.82	14.67	43.49	54.00	-10.51	AVG
3	X	5262.400	70.69	14.85	85.54			peak
4	*	5265.200	60.01	14.84	74.85			AVG

Remark:

1. Corr. = Antenna Factor (dB/m) + Cable Loss (dB)
2. Peak/AVG (dBμV/m) = Corr. (dB/m) + Read Level (dBμV)
3. Margin (dB) = Peak/AVG (dBμV/m) - Limit PK/AVG (dBμV/m)

Temperature:	25 °C	Relative Humidity:	55%
Test Voltage:	DC 3.8V		
Ant. Pol.	Horizontal		
Test Mode:	TX 802.11n(HT20) Mode 5320 MHz (U-NII-2A)		
Remark:			

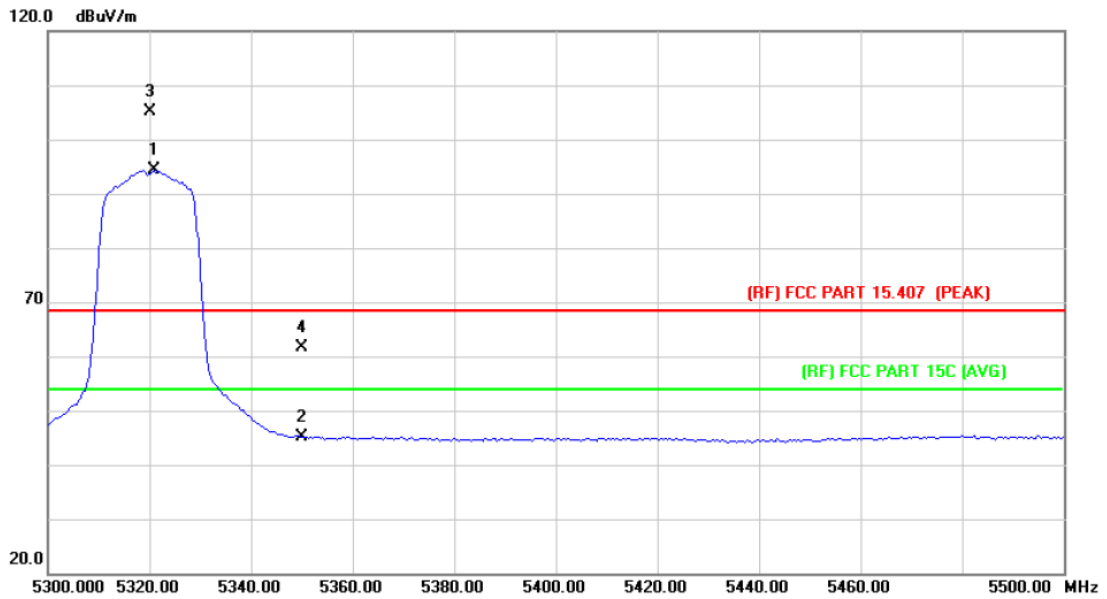

No.	Mk.	Freq.	Reading Level	Correct Factor	Measurement	Limit	Over	Detector
		MHz	dBuV	dB/m	dBuV/m	dBuV/m	dB	
1	*	5320.800	79.40	14.92	94.32	Fundamental Frequency		AVG
2		5350.000	30.18	14.97	45.15	54.00	-8.85	AVG
3	X	5320.000	90.29	14.92	105.21	Fundamental Frequency		peak
4		5350.000	46.65	14.97	61.62	68.30	-6.68	peak

Remark:

1. Corr. = Antenna Factor (dB/m) + Cable Loss (dB)
2. Peak/AVG (dBμV/m)= Corr. (dB/m)+ Read Level (dBμV)
3. Margin (dB) = Peak/AVG (dBμV/m)-Limit PK/AVG(dBμV/m)

Temperature:	25 °C	Relative Humidity:	55%
Test Voltage:	DC 3.8V		
Ant. Pol.	Vertical		
Test Mode:	TX 802.11n(HT20) Mode 5320 MHz (U-NII-2A)		
Remark:			

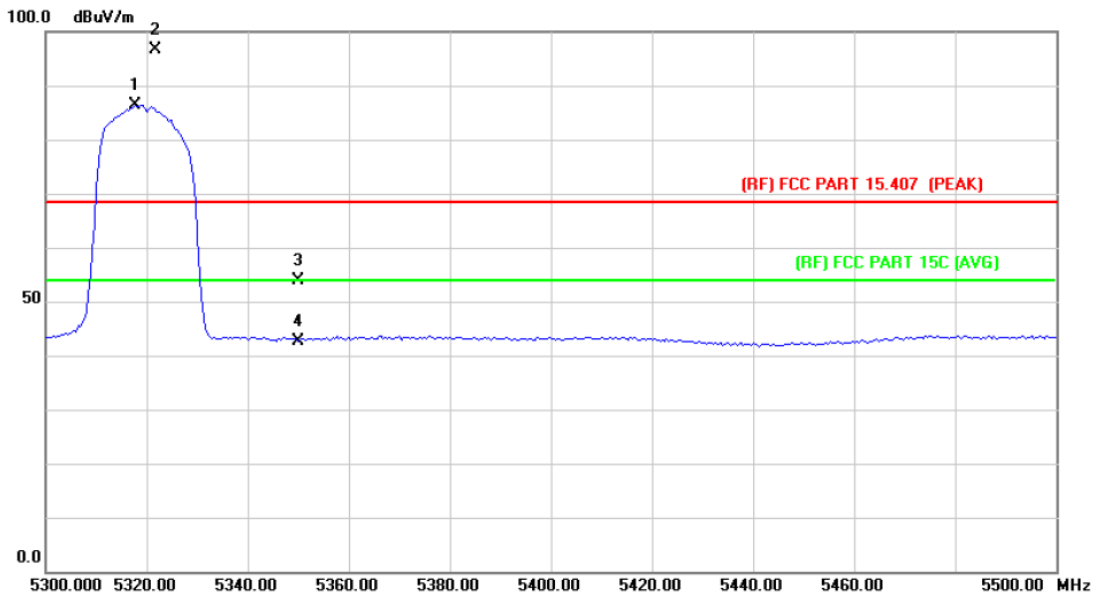

No.	Mk.	Freq. MHz	Reading Level dBuV	Correct Factor dB/m	Measure- ment dBuV/m	Limit dBuV/m	Over dB	Detector
1	*	5317.600	71.52	14.91	86.43	Fundamental Frequency		AVG
2	X	5321.600	81.70	14.92	96.62	Fundamental Frequency		peak
3		5350.000	39.03	14.97	54.00	68.30	-14.30	peak
4		5350.000	27.78	14.97	42.75	54.00	-11.25	AVG

Remark:

1. Corr. = Antenna Factor (dB/m) + Cable Loss (dB)
2. Peak/AVG (dBμV/m)= Corr. (dB/m)+ Read Level (dBμV)
3. Margin (dB) = Peak/AVG (dBμV/m)-Limit PK/AVG(dBμV/m)

Temperature:	25 °C	Relative Humidity:	55%
Test Voltage:	DC 3.8V		
Ant. Pol.	Horizontal		
Test Mode:	TX 802.11ac(VHT20) Mode 5260 MHz (U-NII-2A)		
Remark:			

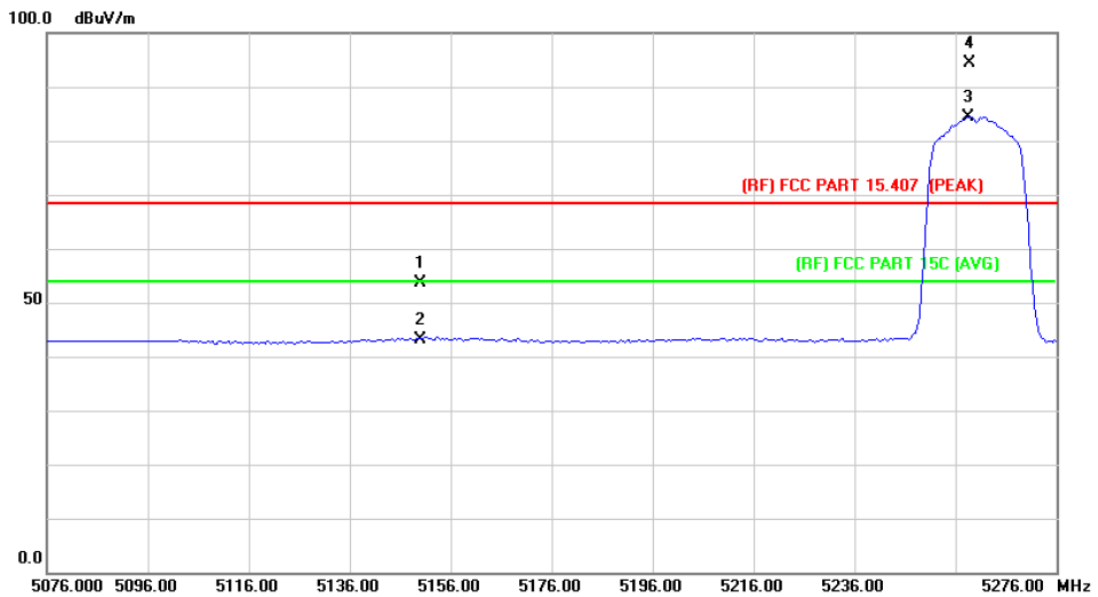

No.	Mk.	Freq. MHz	Reading Level dBuV	Correct Factor dB/m	Measure- ment dBuV/m	Limit dBuV/m	Over dB	Detector
1		5150.000	39.04	14.67	53.71	68.30	-14.59	peak
2		5150.000	28.58	14.67	43.25	54.00	-10.75	AVG
3	*	5258.600	69.55	14.83	84.38	Fundamental Frequency		AVG
4	X	5258.800	79.63	14.83	94.46	Fundamental Frequency		peak

Remark:

1. Corr. = Antenna Factor (dB/m) + Cable Loss (dB)
2. Peak/AVG (dBμV/m)= Corr. (dB/m)+ Read Level (dBμV)
3. Margin (dB) = Peak/AVG (dBμV/m)-Limit PK/AVG(dBμV/m)

Temperature:	25 °C	Relative Humidity:	55%
Test Voltage:	DC 3.8V		
Ant. Pol.	Vertical		
Test Mode:	TX 802.11ac(VHT20) Mode 5260 MHz (U-NII-2A)		
Remark:			

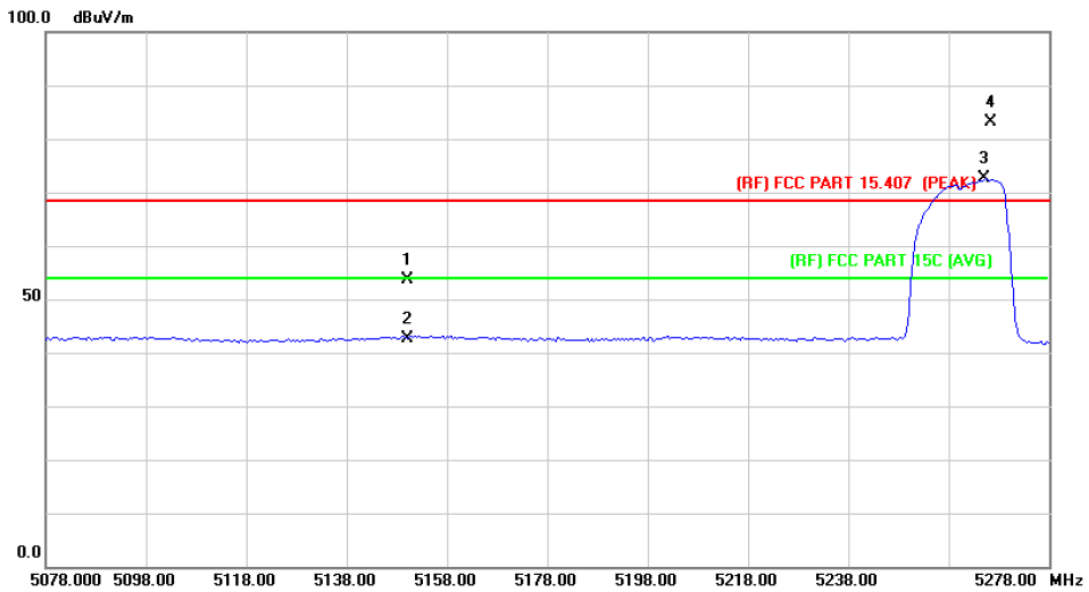

No.	Mk.	Freq. MHz	Reading Level dBuV	Correct Factor dB/m	Measure- ment dBuV/m	Limit dBuV/m	Over dB	Detector
1		5150.000	38.98	14.67	53.65	68.30	-14.65	peak
2		5150.000	28.07	14.67	42.74	54.00	-11.26	AVG
3	*	5265.200	57.72	14.84	72.56	Fundamental Frequency		AVG
4	X	5266.400	68.24	14.84	83.08	Fundamental Frequency		peak

Remark:

1. Corr. = Antenna Factor (dB/m) + Cable Loss (dB)
2. Peak/AVG (dBuV/m) = Corr. (dB/m) + Read Level (dBuV)
3. Margin (dB) = Peak/AVG (dBuV/m) - Limit PK/AVG (dBuV/m)

Temperature:	25 °C	Relative Humidity:	55%
Test Voltage:	DC 3.8V		
Ant. Pol.	Horizontal		
Test Mode:	TX 802.11ac(VHT20) Mode 5320 MHz (U-NII-2A)		
Remark:			

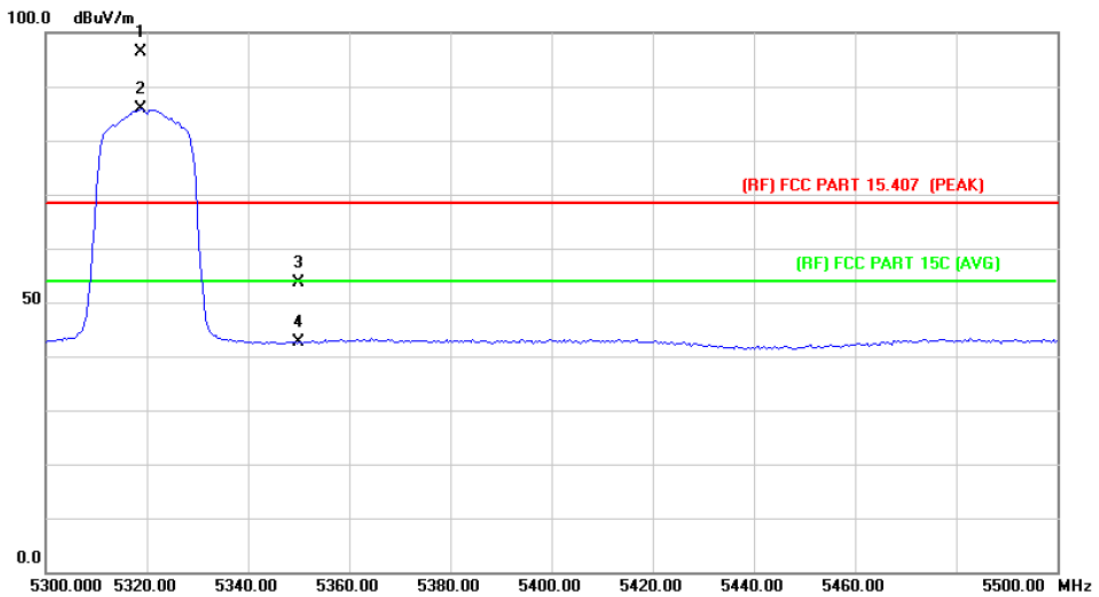

No.	Mk.	Freq. MHz	Reading Level dBuV	Correct Factor dB/m	Measurement dBuV/m	Limit dBuV/m	Over dB	Detector
1	X	5318.800	81.44	14.92	96.36	Fundamental Frequency		peak
2	*	5318.800	70.98	14.92	85.90	Fundamental Frequency		AVG
3		5350.000	38.73	14.97	53.70	68.30	-14.60	peak
4		5350.000	27.54	14.97	42.51	54.00	-11.49	AVG

Remark:

1. Corr. = Antenna Factor (dB/m) + Cable Loss (dB)
2. Peak/AVG (dBμV/m)= Corr. (dB/m)+ Read Level (dBμV)
3. Margin (dB) = Peak/AVG (dBμV/m)-Limit PK/AVG(dBμV/m)

Temperature:	25 °C	Relative Humidity:	55%
Test Voltage:	DC 3.8V		
Ant. Pol.	Vertical		
Test Mode:	TX 802.11ac(VHT20) Mode 5320 MHz (U-NII-2A)		
Remark:			

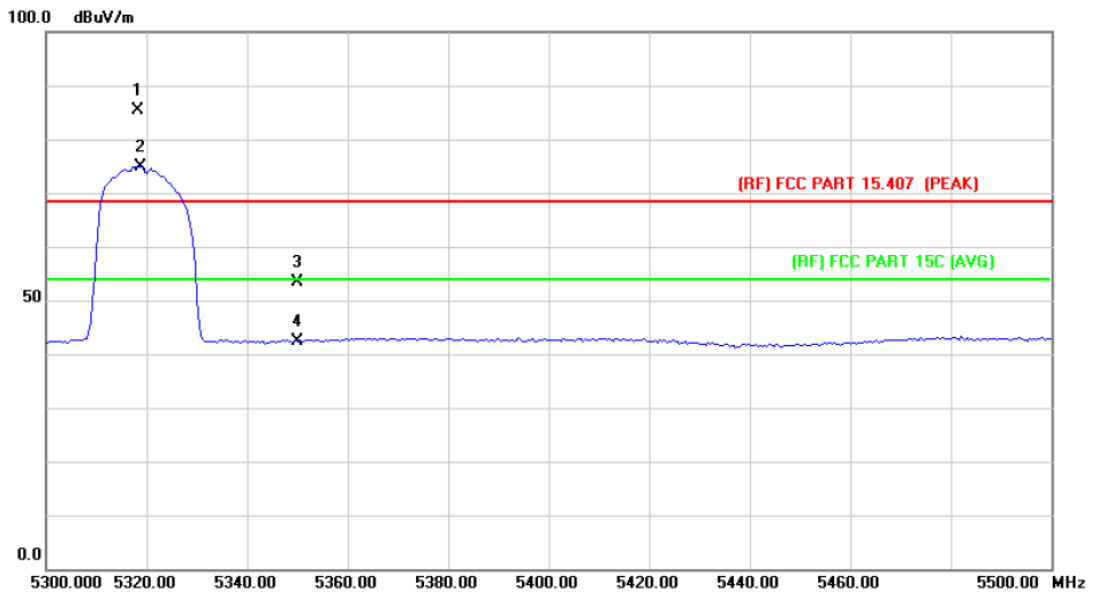

No.	Mk.	Freq. MHz	Reading Level dBuV	Correct Factor dB/m	Measure- ment dBuV/m	Limit dBuV/m	Over dB	Detector
1	X	5318.400	70.58	14.92	85.50	Fundamental Frequency		peak
2	*	5318.800	60.06	14.92	74.98	Fundamental Frequency		AVG
3		5350.000	38.43	14.97	53.40	68.30	-14.90	peak
4		5350.000	27.40	14.97	42.37	54.00	-11.63	AVG

Remark:

1. Corr. = Antenna Factor (dB/m) + Cable Loss (dB)
2. Peak/AVG (dBμV/m)= Corr. (dB/m)+ Read Level (dBμV)
3. Margin (dB) = Peak/AVG (dBμV/m)-Limit PK/AVG(dBμV/m)

Temperature:	25 °C	Relative Humidity:	55%
Test Voltage:	DC 3.8V		
Ant. Pol.	Horizontal		
Test Mode:	TX 802.11n(HT40) Mode 5270 MHz (U-NII-2A)		
Remark:			

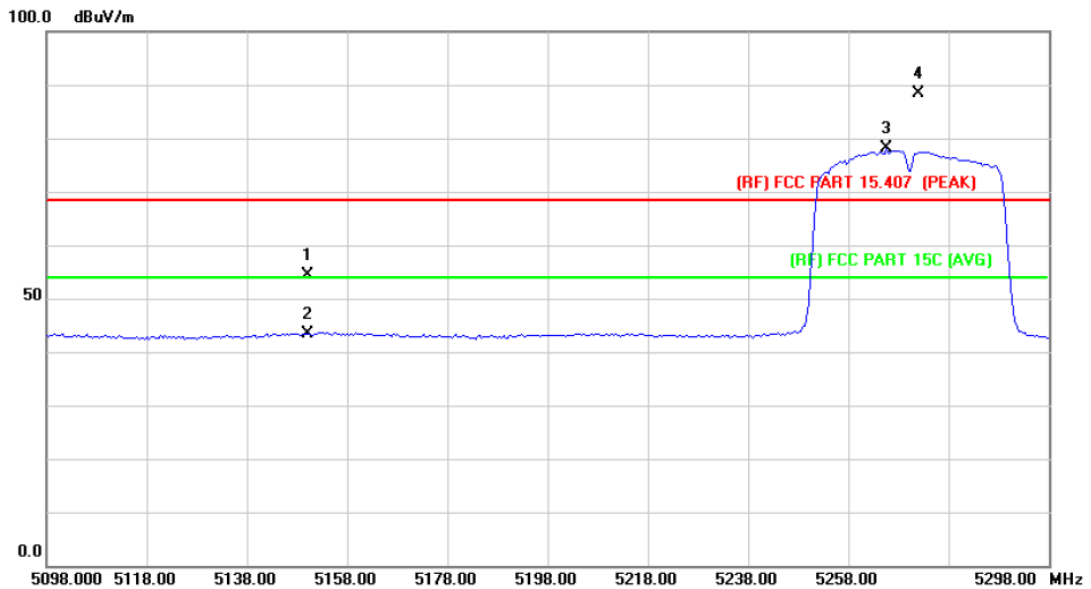

No.	Mk.	Freq. MHz	Reading Level dBuV	Correct Factor dB/m	Measure- ment dBuV/m	Limit dBuV/m	Over dB	Detector
1		5150.000	39.71	14.67	54.38	68.30	-13.92	peak
2		5150.000	28.67	14.67	43.34	54.00	-10.66	AVG
3	*	5265.600	63.20	14.84	78.04	Fundamental Frequency		AVG
4	X	5272.000	73.64	14.85	88.49	Fundamental Frequency		peak

Remark:

1. Corr. = Antenna Factor (dB/m) + Cable Loss (dB)
2. Peak/AVG (dBuV/m) = Corr. (dB/m) + Read Level (dBuV)
3. Margin (dB) = Peak/AVG (dBuV/m) - Limit PK/AVG (dBuV/m)

Temperature:	25 °C	Relative Humidity:	55%
Test Voltage:	DC 3.8V		
Ant. Pol.	Vertical		
Test Mode:	TX 802.11n(HT40) Mode 5270 MHz (U-NII-2A)		
Remark:			

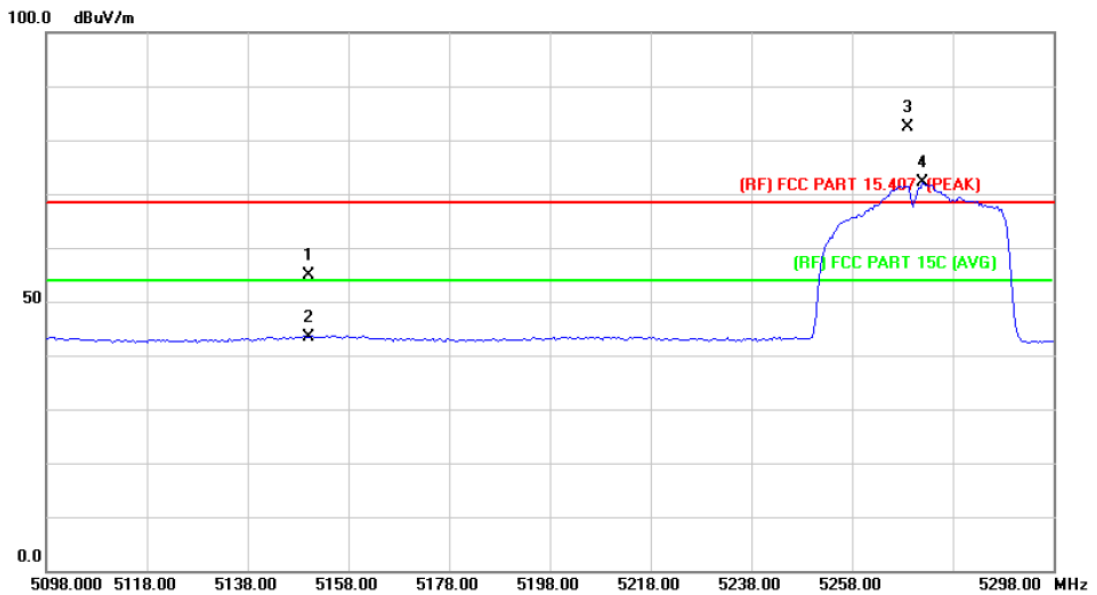

No.	Mk.	Freq. MHz	Reading Level dBuV	Correct Factor dB/m	Measure- ment dBuV/m	Limit dBuV/m	Over dB	Detector
1		5150.000	40.27	14.67	54.94	68.30	-13.36	peak
2		5150.000	28.78	14.67	43.45	54.00	-10.55	AVG
3	X	5269.200	67.50	14.85	82.35	Fundamental Frequency		peak
4	*	5272.000	57.19	14.85	72.04	Fundamental Frequency		AVG

Remark:

1. Corr. = Antenna Factor (dB/m) + Cable Loss (dB)
2. Peak/AVG (dBμV/m)= Corr. (dB/m)+ Read Level (dBμV)
3. Margin (dB) = Peak/AVG (dBμV/m)-Limit PK/AVG(dBμV/m)

Temperature:	25 °C	Relative Humidity:	55%
Test Voltage:	DC 3.8V		
Ant. Pol.	Horizontal		
Test Mode:	TX 802.11n(HT40) Mode 5310 MHz (U-NII-2A)		
Remark:			

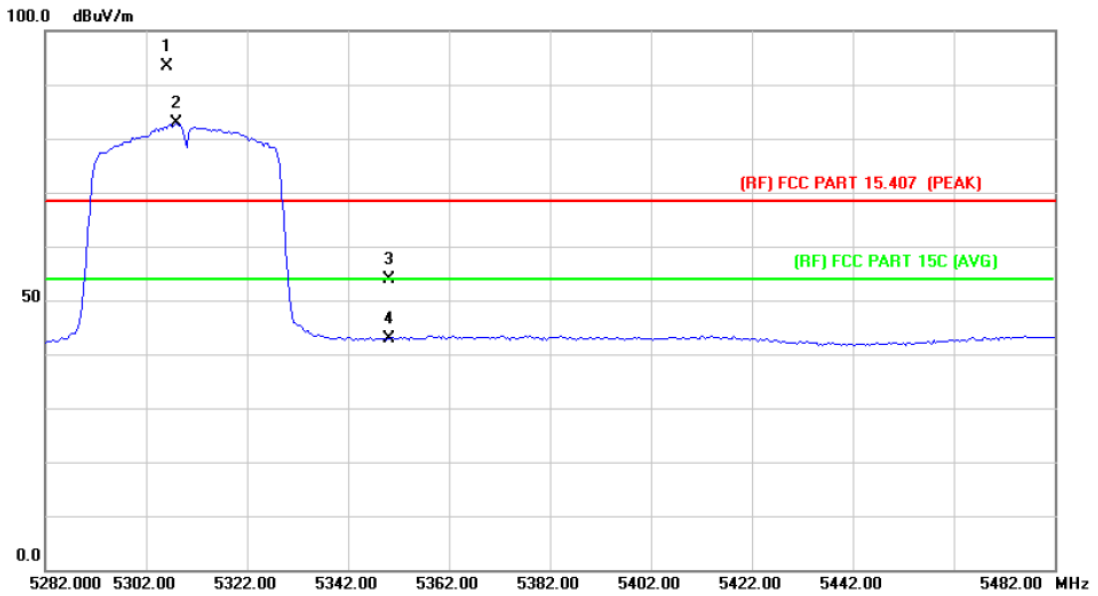

No.	Mk.	Freq. MHz	Reading Level dBuV	Correct Factor dB/m	Measure- ment dBuV/m	Limit dBuV/m	Over dB	Detector
1	X	5306.000	78.36	14.91	93.27			peak
2	*	5308.000	67.90	14.91	82.81			AVG
3		5350.000	38.80	14.97	53.77	68.30	-14.53	peak
4		5350.000	27.89	14.97	42.86	54.00	-11.14	AVG

Remark:

1. Corr. = Antenna Factor (dB/m) + Cable Loss (dB)
2. Peak/AVG (dBμV/m) = Corr. (dB/m) + Read Level (dBμV)
3. Margin (dB) = Peak/AVG (dBμV/m) - Limit PK/AVG (dBμV/m)

Temperature:	25 °C	Relative Humidity:	55%
Test Voltage:	DC 3.8V		
Ant. Pol.	Vertical		
Test Mode:	TX 802.11n(HT40) Mode 5310 MHz (U-NII-2A)		
Remark:			

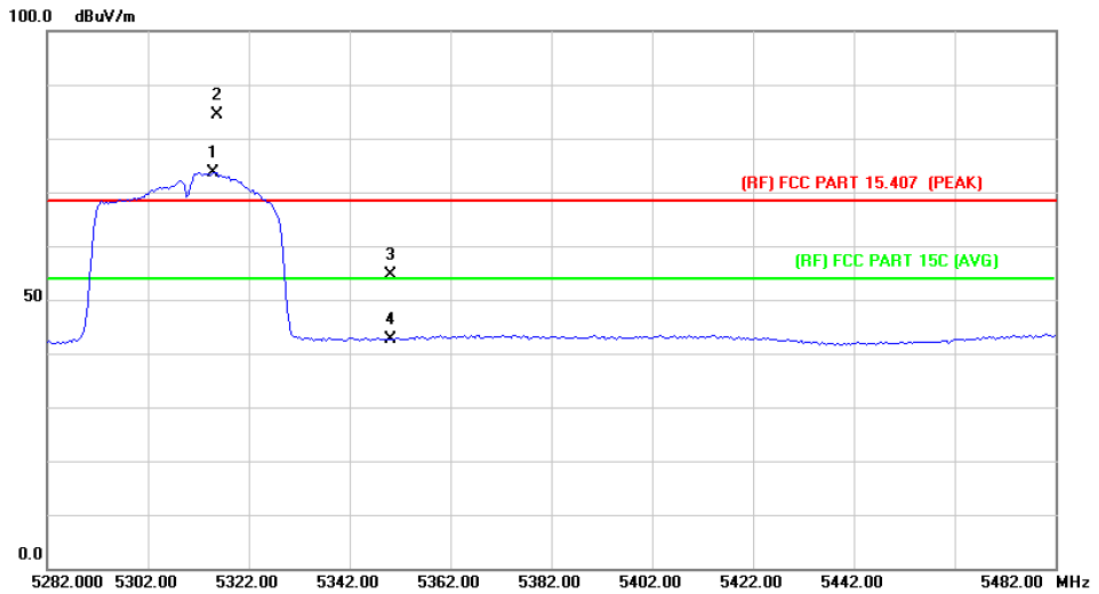

No.	Mk.	Freq. MHz	Reading Level dBuV	Correct Factor dB/m	Measure- ment dBuV/m	Limit dBuV/m	Over dB	Detector
1	*	5314.800	58.75	14.91	73.66			AVG
2	X	5315.600	69.54	14.91	84.45			peak
3		5350.000	39.67	14.97	54.64	68.30	-13.66	peak
4		5350.000	27.71	14.97	42.68	54.00	-11.32	AVG

Remark:

1. Corr. = Antenna Factor (dB/m) + Cable Loss (dB)
2. Peak/AVG (dBμV/m)= Corr. (dB/m)+ Read Level (dBμV)
3. Margin (dB) = Peak/AVG (dBμV/m)-Limit PK/AVG(dBμV/m)

Temperature:	25 °C	Relative Humidity:	55%
Test Voltage:	DC 3.8V		
Ant. Pol.	Horizontal		
Test Mode:	TX 802.11ac(VHT40) Mode 5270 MHz (U-NII-2A)		
Remark:			

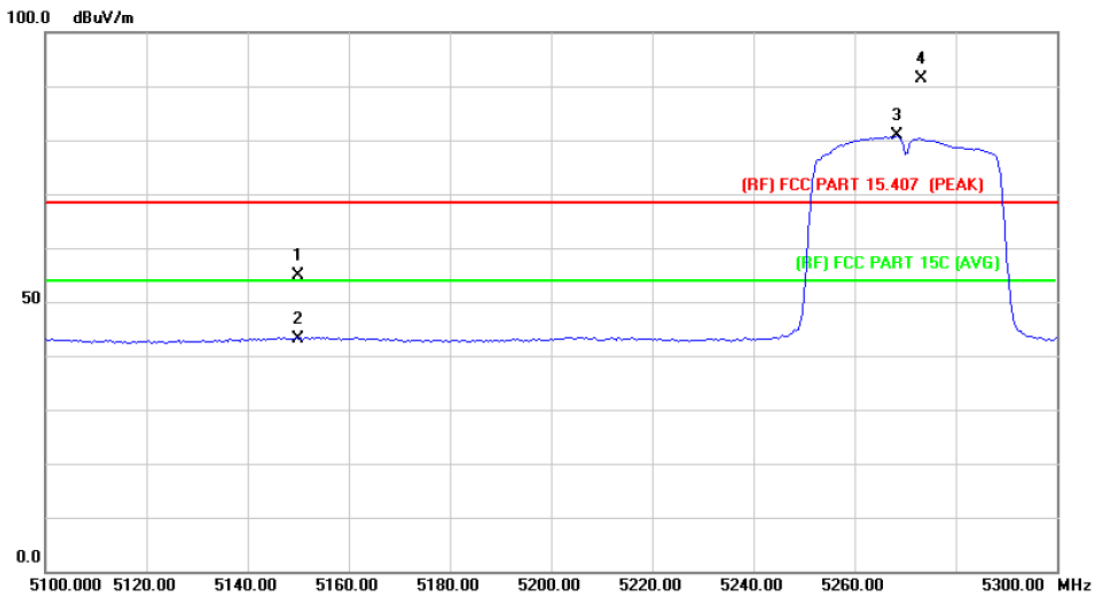

No.	Mk.	Freq. MHz	Reading Level dBuV	Correct Factor dB/m	Measure- ment dBuV/m	Limit dBuV/m	Over dB	Detector
1		5150.000	40.31	14.67	54.98	68.30	-13.32	peak
2		5150.000	28.44	14.67	43.11	54.00	-10.89	AVG
3	*	5268.400	65.91	14.85	80.76	Fundamental Frequency		AVG
4	X	5273.200	76.42	14.85	91.27	Fundamental Frequency		peak

Remark:

1. Corr. = Antenna Factor (dB/m) + Cable Loss (dB)
2. Peak/AVG (dBμV/m)= Corr. (dB/m)+ Read Level (dBμV)
3. Margin (dB) = Peak/AVG (dBμV/m)-Limit PK/AVG(dBμV/m)