



MET Laboratories, Inc. *Safety Certification - EMI - Telecom Environmental Simulation*

914 WEST PATAPSCO AVENUE • BALTIMORE, MARYLAND 21230-3432 • PHONE (410) 354-3300 • FAX (410) 354-3313

33439 WESTERN AVENUE • UNION CITY, CALIFORNIA 94587 • PHONE (510) 489-6300 • FAX (510) 489-6372

3162 BELICK STREET • SANTA CLARA, CA 95054 • PHONE (408) 748-3585 • FAX (510) 489-6372

13501 MCCALLEN PASS • AUSTIN, TEXAS 78753 • PHONE (512) 287-2500 • FAX (512) 287-2513

September 28, 2015

Digital Receiver Technology, Inc.
12409 Milestone Center Dr.
Germantown, MD 20876

Dear Steve Hudson,

Enclosed is the EMC Wireless test report for compliance testing of the Digital Receiver Technology, Inc., DRT9955C-1 as tested to the requirements of the FCC Certification rules under Title 47 of the CFR Part 22 Subpart H for Cellular Devices and FCC Part 24 Subpart E for Broadband PCS Devices.

Thank you for using the services of MET Laboratories, Inc. If you have any questions regarding these results or if MET can be of further service to you, please contact me.

Sincerely yours,
MET LABORATORIES, INC.

Jennifer Warnell
Documentation Department

Reference: (\\Digital Receiver Technology, Inc.\\EMC84362-FCC22_24 Rev. 1)

Certificates and reports shall not be reproduced except in full, without the written permission of MET Laboratories, Inc.



MET Laboratories, Inc. *Safety Certification - EMI - Telecom Environmental Simulation*

914 WEST PATAPSCO AVENUE • BALTIMORE, MARYLAND 21230-3432 • PHONE (410) 354-3300 • FAX (410) 354-3313

33439 WESTERN AVENUE • UNION CITY, CALIFORNIA 94587 • PHONE (510) 489-6300 • FAX (510) 489-6372

3162 BELICK STREET • SANTA CLARA, CA 95054 • PHONE (408) 748-3585 • FAX (510) 489-6372

13501 MCCALLEN PASS • AUSTIN, TEXAS 78753 • PHONE (512) 287-2500 • FAX (512) 287-2513

**Electromagnetic Compatibility Criteria
Test Report**

for the

**Digital Receiver Technology, Inc.
Model DRT9955C-1**

**Tested under
FCC Certification Rules
Title 47 of the CFR,
Part 22 Subpart H for Cellular Devices
&
Part 24 Subpart E for Broadband PCS Devices**

MET Report: EMC84362-FCC22_24 Rev. 1

September 28, 2015

Prepared For:

**Digital Receiver Technology, Inc.
12409 Milestone Center Dr.
Germantown, MD 20876**

**Prepared By:
MET Laboratories, Inc.
914 W. Patapsco Ave
Baltimore, MD 21230**



Electromagnetic Compatibility Criteria Test Report

for the

Digital Receiver Technology, Inc.
Model DRT9955C-1

Tested Under
FCC Certification Rules
Title 47 of the CFR,
Part 22 Subpart H for Cellular Devices
&
Part 24 Subpart E for Broadband PCS Devices

Benjamin Taylor
Project Engineer, Electromagnetic Compatibility Lab

Jennifer Warnell
Documentation Department

Engineering Statement: The measurements shown in this report were made in accordance with the procedures indicated, and the emissions from this equipment were found to be within the limits applicable. I assume full responsibility for the accuracy and completeness of these measurements, and for the qualifications of all persons taking them. It is further stated that upon the basis of the measurements made, the equipment tested is capable of operation in accordance with the requirements of Part 22 Subpart H and Part 15 Subpart B of the FCC Rules under normal use and maintenance.

Asad Bajwa,
Director, Electromagnetic Compatibility Lab



Report Status Sheet

Revision	Report Date	Reason for Revision
∅	August 31, 2015	Initial Issue
1	September 28, 2015	Updated to include power measurement data in tabular format.



Table of Contents

I.	Executive Summary	1
	A. Purpose of Test	2
	B. Executive Summary	2
II.	Equipment Configuration	3
	A. Overview.....	4
	B. References.....	5
	C. Test Site	5
	D. Description of Test Sample.....	5
	E. Equipment Configuration.....	6
	F. Support Equipment	6
	G. Mode of Operation.....	7
	H. Method of Monitoring EUT Operation	7
	I. Modifications	7
	Modifications to EUT	7
	Modifications to Test Standard.....	7
	J. Disposition of EUT	7
III.	Electromagnetic Compatibility Criteria for Intentional Radiators.....	8
	§ 2.1046 RF Power Output.....	9
	§ 2.1049 Occupied Bandwidth	29
	§ 2.1053 Radiated Spurious Emissions	42
	§ 2.1051 Spurious Emissions at Antenna Terminals	48
	Filter Response	67
	Intermodulation	70
IV.	Test Equipment	75

List of Tables

Table 1.	Executive Summary of EMC Compliance Testing	2
Table 2.	Equipment Configuration	6
Table 3.	Support Equipment.....	6
Table 4.	RF Output Power Measurements, Test Results	10



List of Terms and Abbreviations

AC	Alternating Current
ACF	Antenna Correction Factor
Cal	Calibration
<i>d</i>	Measurement Distance
dB	Decibels
dB μ A	Decibels above one microamp
dB μ V	Decibels above one microvolt
dB μ A/m	Decibels above one microamp per meter
dB μ V/m	Decibels above one microvolt per meter
DC	Direct Current
E	Electric Field
DSL	Digital Subscriber Line
ESD	Electrostatic Discharge
EUT	Equipment Under Test
<i>f</i>	Frequency
FCC	Federal Communications Commission
GRP	Ground Reference Plane
H	Magnetic Field
HCP	Horizontal Coupling Plane
Hz	Hertz
IEC	International Electrotechnical Commission
kHz	kilohertz
kPa	kilopascal
kV	kilovolt
LISN	Line Impedance Stabilization Network
MHz	Megahertz
μ H	microhenry
μ	microfarad
μ s	microseconds
NEBS	Network Equipment-Building System
PRF	Pulse Repetition Frequency
RF	Radio Frequency
RMS	Root-Mean-Square
TWT	Traveling Wave Tube
V/m	Volts per meter
VCP	Vertical Coupling Plane



I. Executive Summary



A. Purpose of Test

An EMC evaluation was performed to determine compliance of the Digital Receiver Technology, Inc. DRT9955C-1, with the requirements of Part 22 Subpart H and Part 24 Subpart E. All references are to the most current version of Title 47 of the Code of Federal Regulations in effect. In accordance with §2.1033, the following data is presented in support of the Certification of the DRT9955C-1. Digital Receiver Technology, Inc. should retain a copy of this document which should be kept on file for at least two years after the manufacturing of the DRT9955C-1, has been **permanently** discontinued.

B. Executive Summary

The following tests were conducted on a sample of the equipment for the purpose of demonstrating compliance with Part 22 Subpart H and Part 24 Subpart E, in accordance with Digital Receiver Technology, Inc., purchase order number PO-001128.

Reference	Description	Compliance
Part 22 Subpart H §2.1046; §22.913 Part 24 Subpart E §2.1046; §24.232	RF Power Output	Compliant
§2.1049	Occupied Bandwidth	Compliant
§2.1051; §22.917, §24.238	Conducted Spurious Emissions at Antenna Terminals	Compliant
§2.1053; §22.917, §24.238	Radiated Spurious Emissions from the Cabinet	Compliant
§2.1055; §22.355, §24.135	Frequency stability	Not Applicable
FCC guidance on Amplifiers	Intermodulation	Compliant
FCC guidance on Amplifiers	Filter response	Compliant

Table 1. Executive Summary of EMC Compliance Testing

II. Equipment Configuration

A. Overview

MET Laboratories, Inc. was contracted by Digital Receiver Technology, Inc. to perform testing on the DRT9955C-1, under Digital Receiver Technology, Inc.'s purchase order number PO-001128.

This document describes the test setups, test methods, required test equipment, and the test limit criteria used to perform compliance testing of the Digital Receiver Technology, Inc., DRT9955C-1.

The results obtained relate only to the item(s) tested.

Model(s) Tested:	DRT9955C-1		
Model(s) Covered:	DRT9955C-1		
Filing Status:	Original		
EUT Specifications:	Primary Power: 120 VAC, 60 Hz		
	FCC ID: XLM9955C1		
	Type of Modulations:	GSM, CDMA, and WCDMA	
	Equipment Code:	AMP	
	RF Power Output	Part 22: 44.45dBm	Part 24: 44.58dBm
	EUT Frequency Ranges:	869-894 MHz	1930-1990 MHz
Analysis:	The results obtained relate only to the item(s) tested.		
Environmental Test Conditions:	Temperature: 15-35° C		
	Relative Humidity: 30-60%		
	Barometric Pressure: 860-1060 mbar		
Evaluated by:	Benjamin Taylor		
Date(s):	September 28, 2015		

B. References

CFR 47, Part 22, Subpart H	Federal Communication Commission, Code of Federal Regulations, Title 47, Part 22: Rules and Regulations for Cellular Devices.
CFR 47, Part 24, Subpart E	Federal Communication Commission, Code of Federal Regulations, Title 47, Part 24: Rules and Regulations for Personal Communications Services
ANSI C63.4:20014	Methods and Measurements of Radio-Noise Emissions from Low-Voltage Electrical And Electronic Equipment in the Range of 9 kHz to 40 GHz
ISO/IEC 17025:2005	General Requirements for the Competence of Testing and Calibration Laboratories
EIA/TIA-603-A-2001	Land Mobile FM or PM Communication Equipment Measurement and Performance Standards

C. Test Site

All testing was performed at MET Laboratories, Inc., 914 W. Patapsco Ave, Baltimore, MD 21230. All equipment used in making physical determinations is accurate and bears recent traceability to the National Institute of Standards and Technology.

Radiated Emissions measurements were performed in a 10 meter semi-anechoic chamber (equivalent to an Open Area Test Site). In accordance with §2.948(a)(3), a complete site description is contained at MET Laboratories.

D. Description of Test Sample

The DRT9955C-1, Equipment Under Test (EUT), along with DRT9955C-3, are dual band RF power amplifiers used with DRT base stations operating in the cellular, PCS, and AWS bands.

The DRT9955C -1 operates in the cellular and PCS bands.

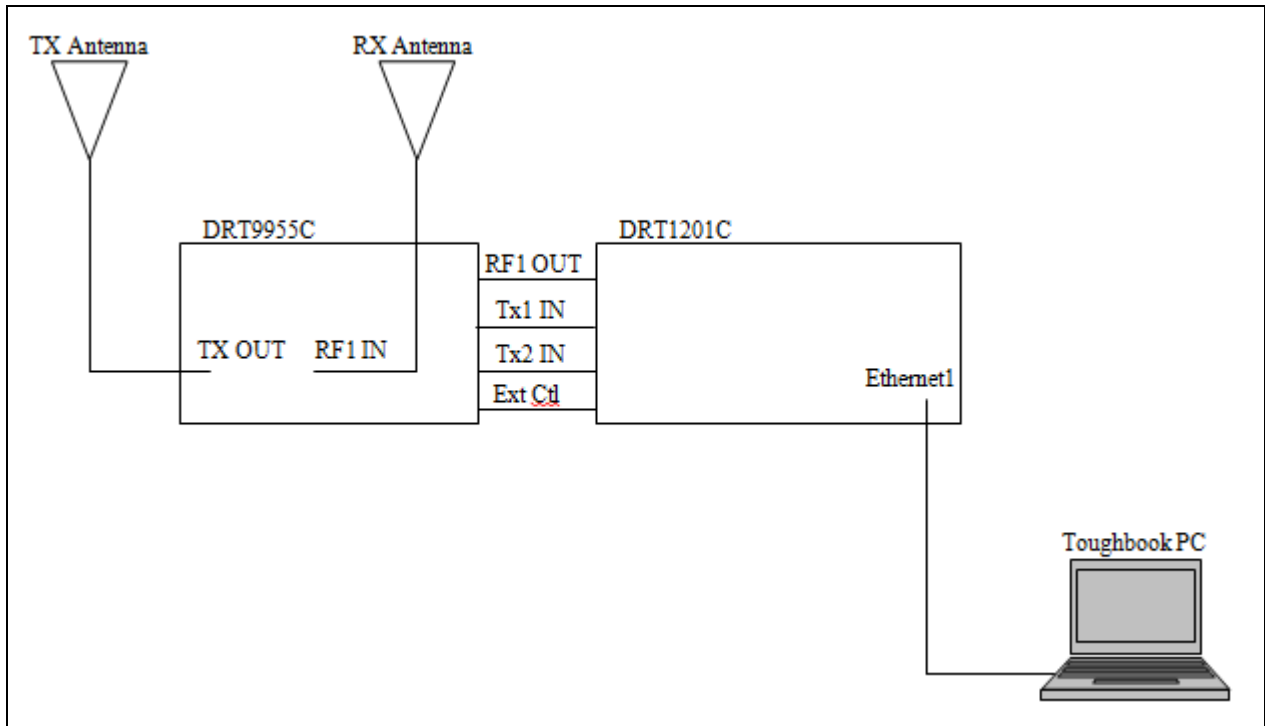

Figure 1. Block Diagram of Equipment Configuration

E. Equipment Configuration

Name / Description	Model Number	Part Number	Serial Number
TRAM	DRT9955C-1	--	240

Table 2. Equipment Configuration

F. Support Equipment

Ref. ID	Name / Description	Manufacturer	Model Number	Customer Supplied Calibration Data
--	Base Station	DRT	DRT1201C	--
--	Toughbook PC	Panasonic	CF-19	--

Table 3. Support Equipment

G. Mode of Operation

Operate as an RF power amplifier for DRT mobile base stations in GSM, CDMA, and WCDMA in the Cellular, PCS, and AWS bands.

The DRT9955C-1 operates in the cellular and PCS bands with GSM, CDMA, and WCDMA modulation.

H. Method of Monitoring EUT Operation

Ran control software on a connected PC.

I. Modifications

a) Modifications to EUT

No modifications were made to the EUT.

b) Modifications to Test Standard

No modifications were made to the test standard.

J. Disposition of EUT

The test sample including all support equipment submitted to the Electro-Magnetic Compatibility Lab for testing was returned to Digital Receiver Technology, Inc.. upon completion of testing.



III. Electromagnetic Compatibility Criteria for Intentional Radiators



Electromagnetic Compatibility Criteria for Intentional Radiators

§ 2.1046 RF Power Output

Test Requirements: § 2.1046 Measurements required: RF power output:

§ 2.1046 (a) For transmitters other than single sideband, independent sideband and controlled carrier radiotelephone, power output shall be measured at the RF output terminals when the transmitter is adjusted in accordance with the tune-up procedure to give the values of current and voltage on the circuit elements specified in § 2.1033(c)(8). The electrical characteristics of the radio frequency load attached to the output terminals when this test is made shall be stated.

§ 2.1046 (b) For single sideband, independent sideband, and single channel, controlled carrier radiotelephone transmitters, the procedure specified in paragraph (a) of this section shall be employed and, in addition, the transmitter shall be modulated during the test as specified and as applicable in § 2.1046 (b) (1-5). In all tests, the input level of the modulating signal shall be such as to develop rated peak envelope power or carrier power, as appropriate, for the transmitter.

§ 2.1046 (c) For measurements conducted pursuant to paragraphs (a) and (b) of this section, all calculations and methods used by the applicant for determining carrier power or peak envelope power, as appropriate, on the basis of measured power in the radio frequency load attached to the transmitter output terminals shall be shown. Under the test conditions specified, no components of the emission spectrum shall exceed the limits specified in the applicable rule parts as necessary for meeting occupied bandwidth or emission limitations.

§ 22.913 Power and antenna height limits.

§ 22.913(a): The Effective radiated power (ERP) of base transmitters and cellular repeaters must not exceed 500 watts.

§ 24.232 Power and antenna height limits.

§ 24.232 (a): (1) Base stations with an emission bandwidth of 1 MHz or less are limited to 1640 watts equivalent isotropically radiated power (EIRP) with an antenna height up to 300 meters HAAT, except as described in paragraph (b) below.

(2) Base stations with an emission bandwidth greater than 1 MHz are limited to 1640 watts/MHz equivalent isotropically radiated power (EIRP) with an antenna height up to 300 meters HAAT.

Test Procedures: As required by 47 CFR 2.1046, RF power output measurements were made at the RF output terminals using an attenuator and spectrum analyzer or power meter. The spectrum analyzer was used in accordance with the licensed measurement guidance procedures. The “Channel Power” measurement feature of the spectrum analyzer was used. Measurements were taken in both high and low power modes, as permissible by compliance with Intermodulation requirements. Lower power mode must be used when operating in multi-channel mode.

Test Results: The EUT complies with the requirements of this section.

Test Engineer(s): Benjamin Taylor

Test Date(s): 08/06/15



Rule Part	Modulation	Frequency (MHz)	Mode	Power (dBm)
22	CDMA	869.7	Single Channel	43.51
22	CDMA	881.5	Single Channel	43.13
22	CDMA	893.3	Single Channel	42.14
22	GSM	869.2	Single Channel	44.08
22	GSM	881.6	Single Channel	43.69
22	GSM	893.8	Single Channel	43.18
22	WCDMA	871.4	Single Channel	44.45
22	WCDMA	881.4	Single Channel	43.39
22	WCDMA	891.6	Single Channel	42.70
22	CDMA	869.7	Multi-Channel	33.41
22	CDMA	881.5	Multi-Channel	32.96
22	CDMA	893.3	Multi-Channel	33.06
22	GSM	869.2	Multi-Channel	34.83
22	GSM	881.6	Multi-Channel	33.22
22	GSM	893.8	Multi-Channel	32.83
22	WCDMA	871.4	Multi-Channel	29.58
22	WCDMA	881.4	Multi-Channel	29.51
22	WCDMA	891.6	Multi-Channel	28.81
24	CDMA	1931	Single Channel	42.19
24	CDMA	1960	Single Channel	43.58
24	CDMA	1989	Single Channel	43.21
24	GSM	1930	Single Channel	43.52
24	GSM	1960	Single Channel	44.27
24	GSM	1990	Single Channel	44.58
24	WCDMA	1932	Single Channel	42.53
24	WCDMA	1960	Single Channel	43.47
24	WCDMA	1988	Single Channel	43.57
24	CDMA	1931	Multi-Channel	30.72
24	CDMA	1960	Multi-Channel	31.79
24	CDMA	1989	Multi-Channel	27.96
24	GSM	1930	Multi-Channel	26.29
24	GSM	1960	Multi-Channel	27.67
24	GSM	1990	Multi-Channel	28.12
24	WCDMA	1932	Multi-Channel	28.28
24	WCDMA	1960	Multi-Channel	29.64
24	WCDMA	1988	Multi-Channel	29.36

Table 4. RF Output Power Measurements, Test Results

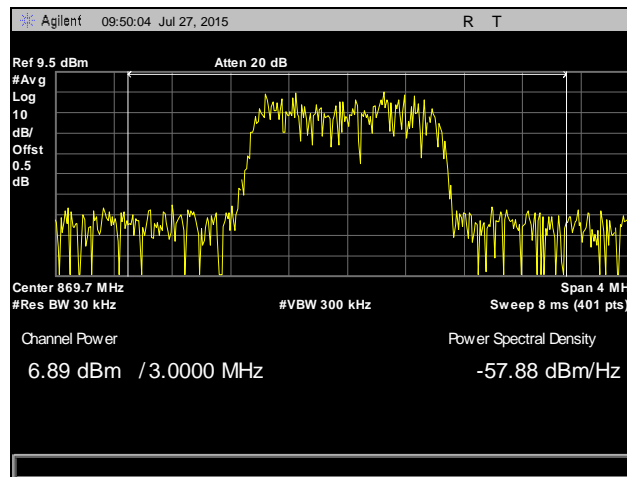

Plot 1. RF Power, Single Channel Operation – High Power, Input CDMA, Low Channel, Part 22

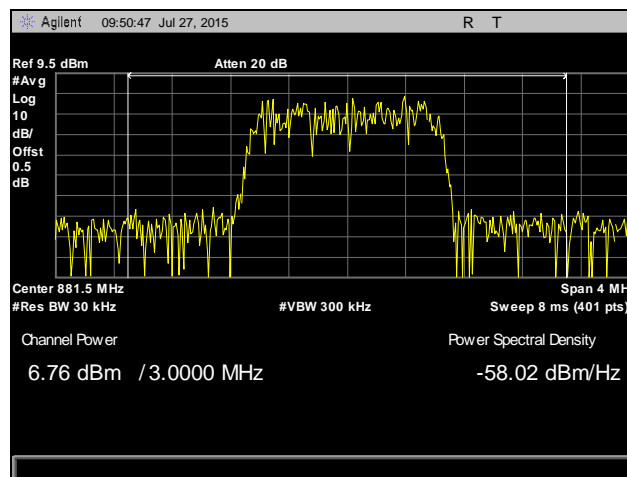

Plot 2. RF Power, Single Channel Operation – High Power, Input CDMA, Mid Channel, Part 22

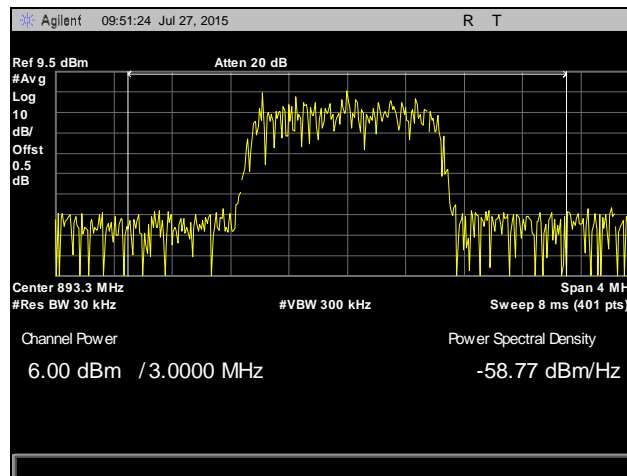

Plot 3. RF Power, Single Channel Operation – High Power, Input CDMA, High Channel, Part 22

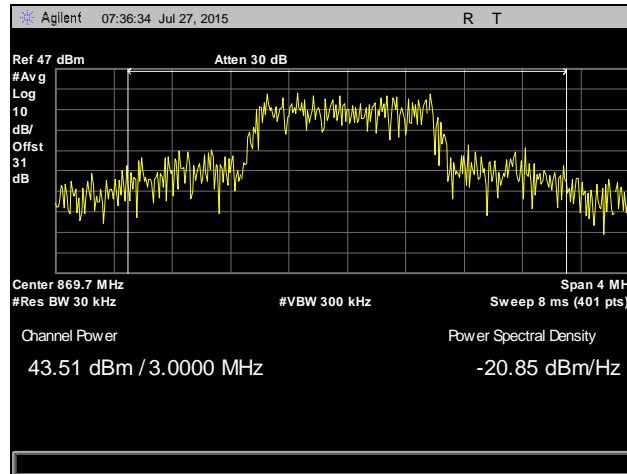

Plot 4. RF Power, Single Channel Operation – High Power, Output CDMA, Low Channel, Part 22

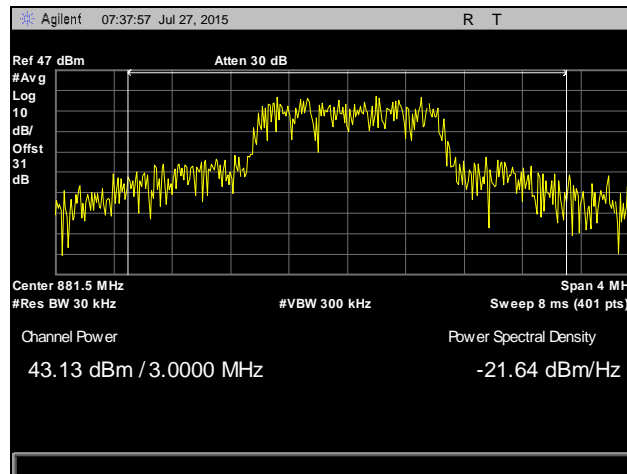

Plot 5. RF Power, Single Channel Operation – High Power, Output CDMA, Mid Channel, Part 22

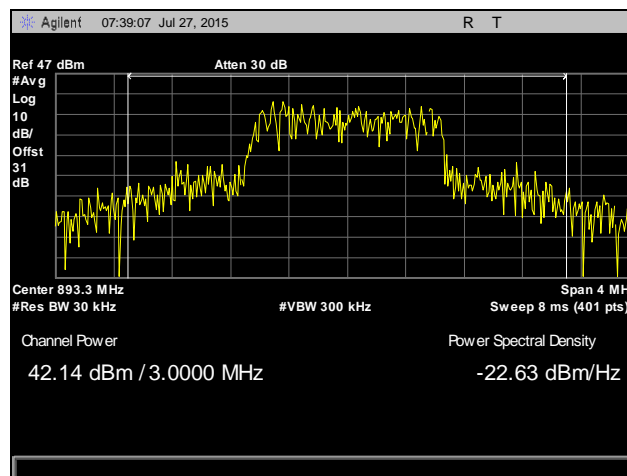

Plot 6. RF Power, Single Channel Operation – High Power, Output CDMA, High Channel, Part 22

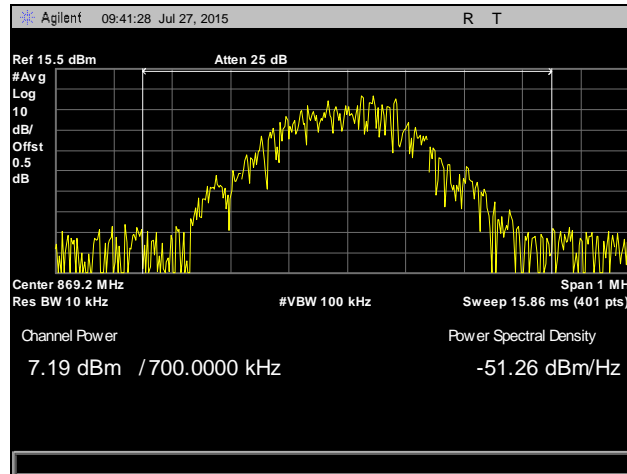

Plot 7. RF Power, Single Channel Operation – High Power, Input GSM, Low Channel, Part 22

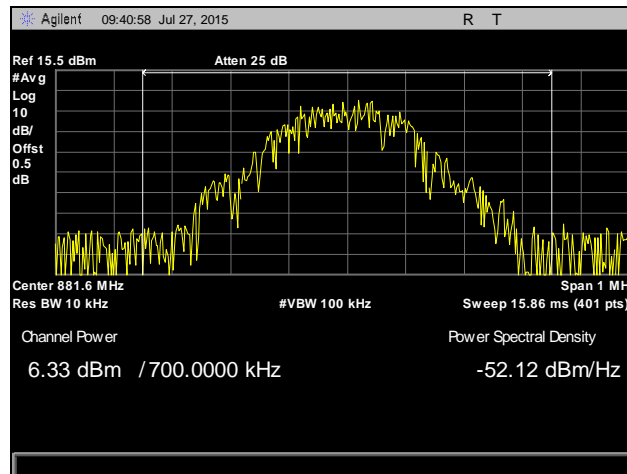

Plot 8. RF Power, Single Channel Operation – High Power, Input GSM, Mid Channel, Part 22

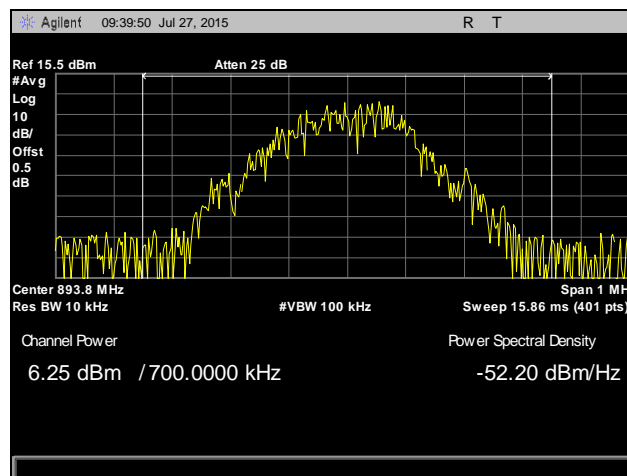

Plot 9. RF Power, Single Channel Operation – High Power, Input GSM, High Channel, Part 22

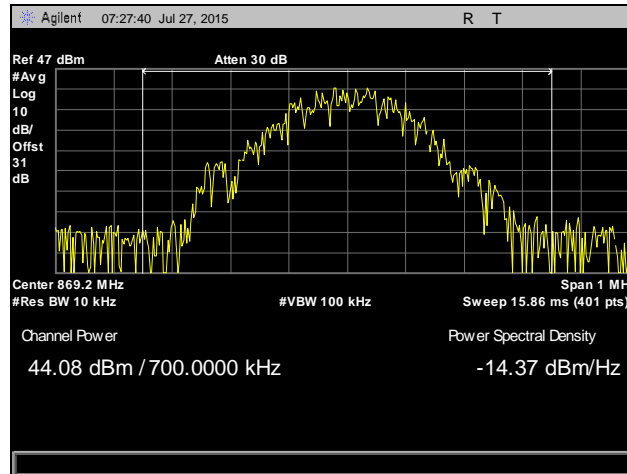

Plot 10. RF Power, Single Channel Operation – High Power, Output GSM, Low Channel, Part 22

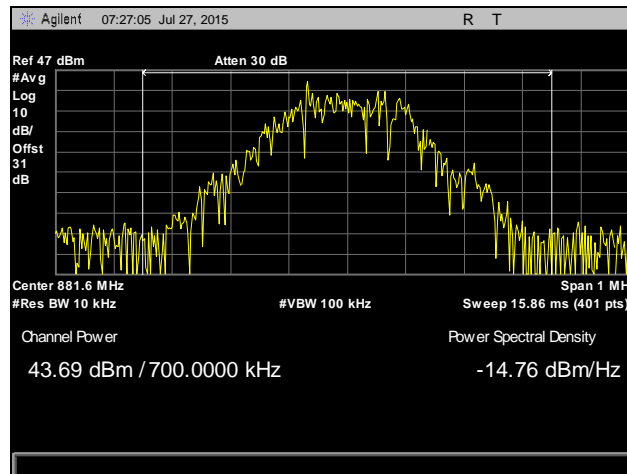

Plot 11. RF Power, Single Channel Operation – High Power, Output GSM, Mid Channel, Part 22

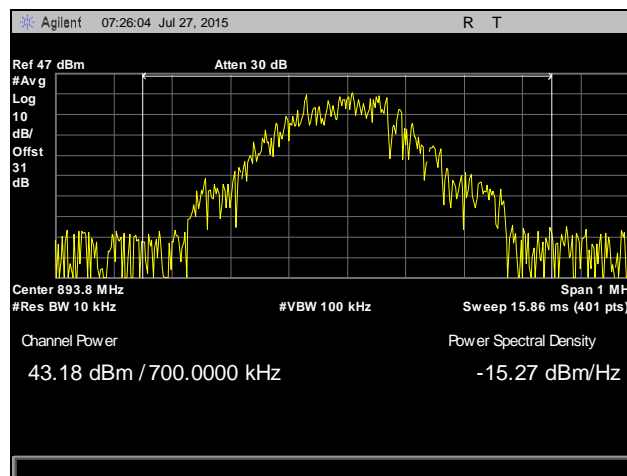

Plot 12. RF Power, Single Channel Operation – High Power, Output GSM, High Channel, Part 22

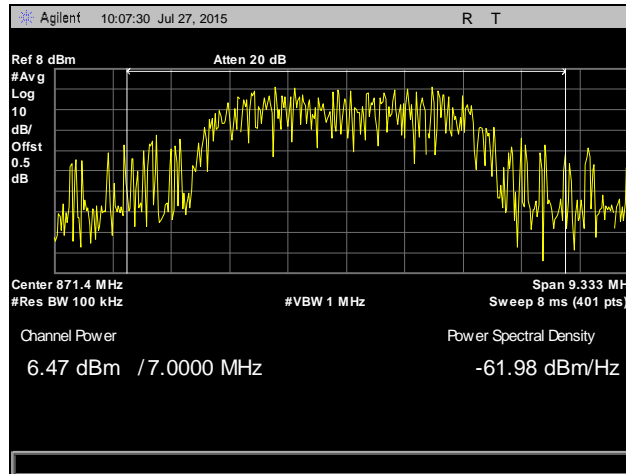

Plot 13. RF Power, Single Channel Operation – High Power, Input WCDMA, Low Channel, Part 22

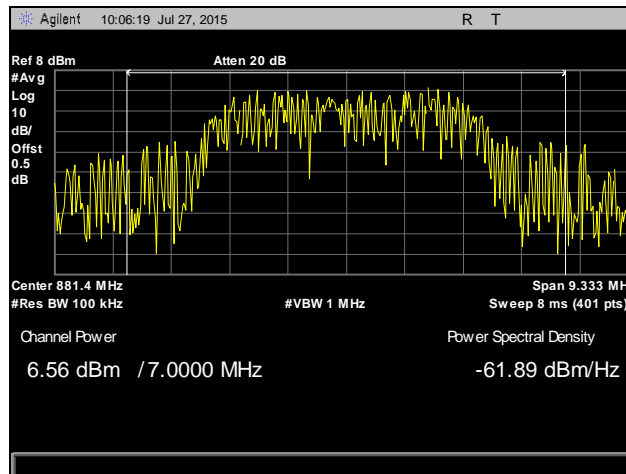

Plot 14. RF Power, Single Channel Operation – High Power, Input WCDMA, Mid Channel, Part 22

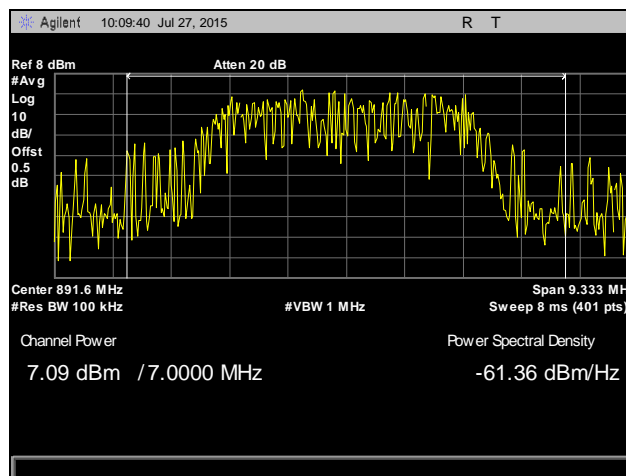

Plot 15. RF Power, Single Channel Operation – High Power, Input WCDMA, High Channel, Part 22

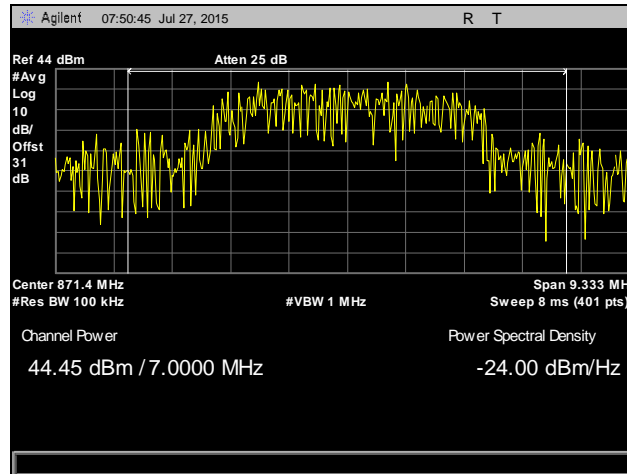

Plot 16. RF Power, Single Channel Operation – High Power, Output WCDMA, Low Channel, Part 22

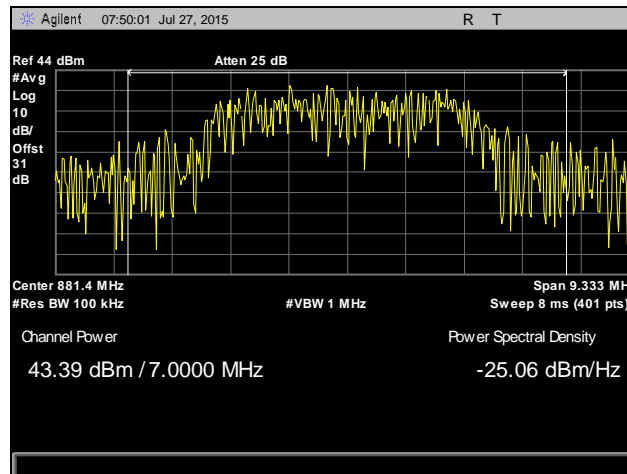

Plot 17. RF Power, Single Channel Operation – High Power, Output WCDMA, Mid Channel, Part 22

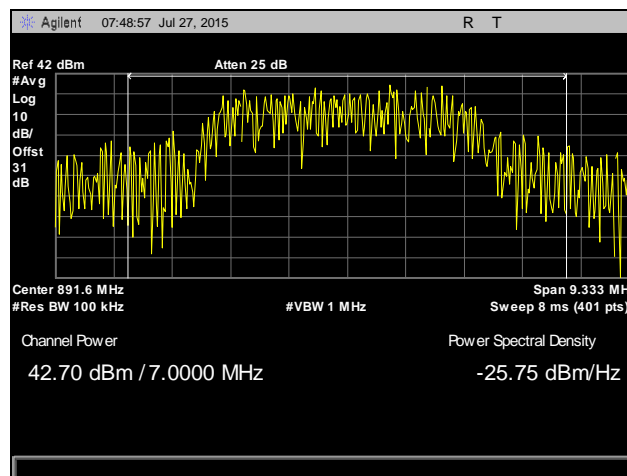

Plot 18. RF Power, Single Channel Operation – High Power, Output WCDMA, High Channel, Part 22

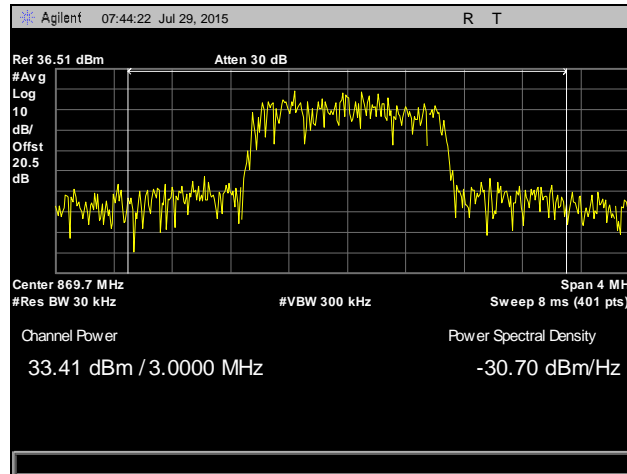

Plot 19. RF Power, Multi-Channel Operation – Reduced Power, Output CDMA, Low Channel, Part 22

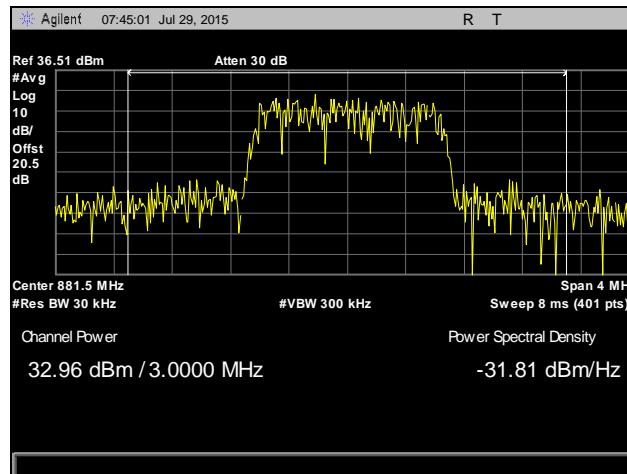

Plot 20. RF Power, Multi-Channel Operation – Reduced Power, Output CDMA, Mid Channel, Part 22

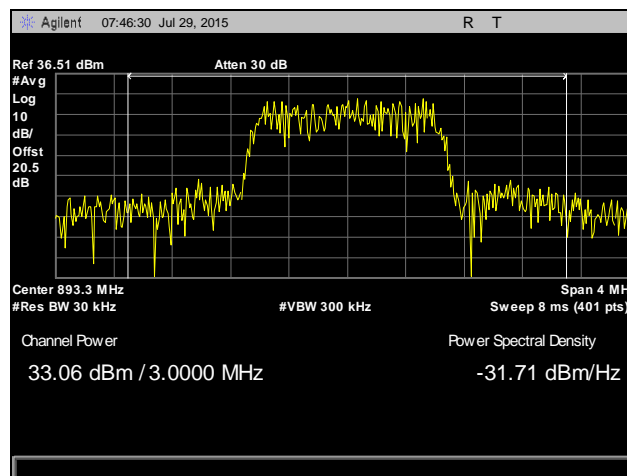

Plot 21. RF Power, Multi-Channel Operation – Reduced Power, Output CDMA, High Channel, Part 22

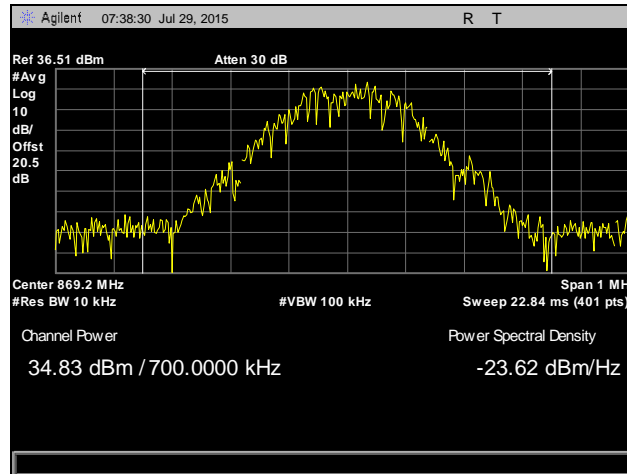

Plot 22. RF Power, Multi-Channel Operation – Reduced Power, Output GSM, Low Channel, Part 22

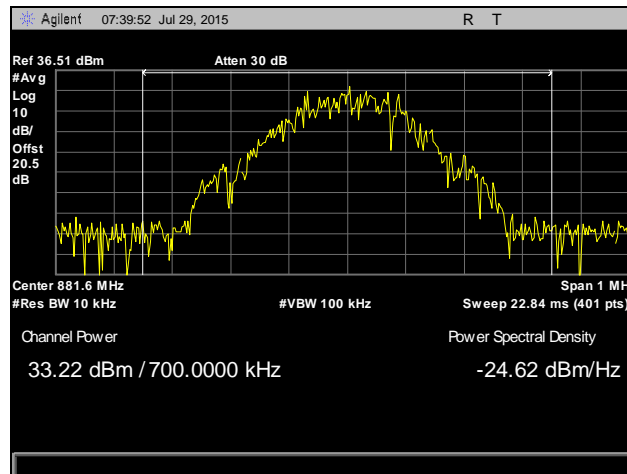

Plot 23. RF Power, Multi-Channel Operation – Reduced Power, Output GSM, Mid Channel, Part 22

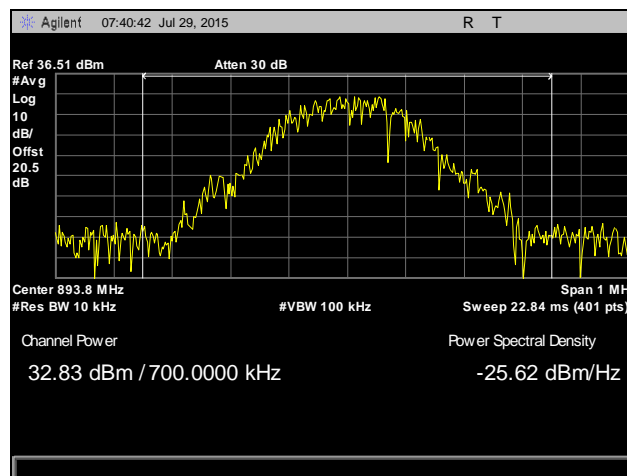

Plot 24. RF Power, Multi-Channel Operation – Reduced Power, Output GSM, High Channel, Part 22

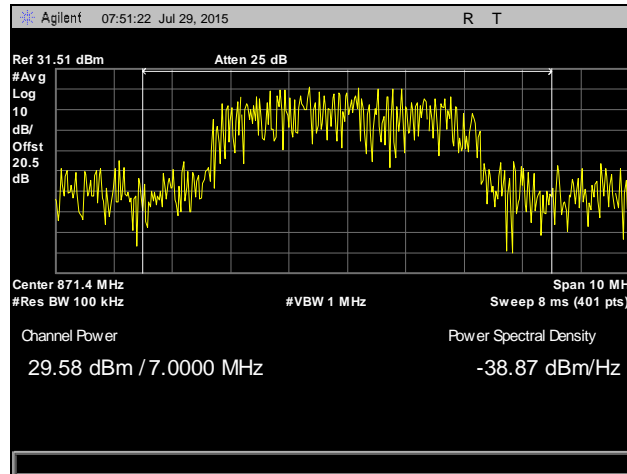

Plot 25. RF Power, Multi-Channel Operation – Reduced Power, Output WCDMA, Low Channel, Part 22

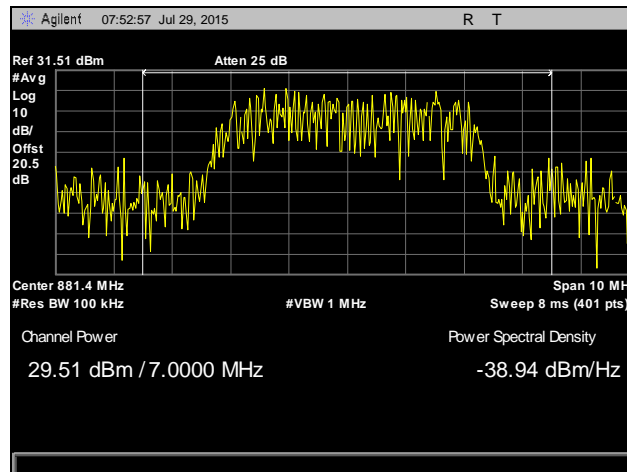

Plot 26. RF Power, Multi-Channel Operation – Reduced Power, Output WCDMA, Mid Channel, Part 22

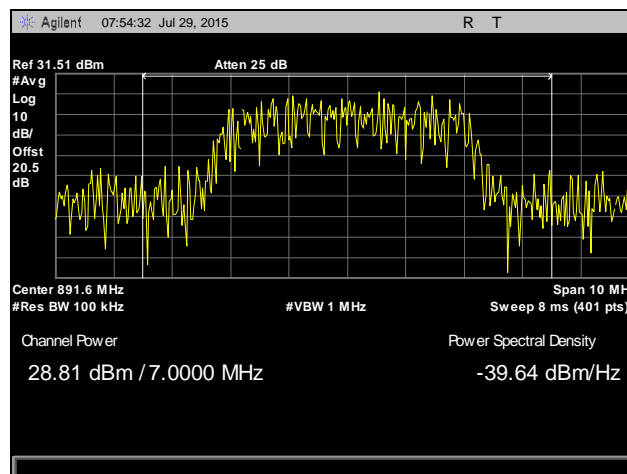

Plot 27. RF Power, Multi-Channel Operation – Reduced Power, Output WCDMA, High Channel, Part 22

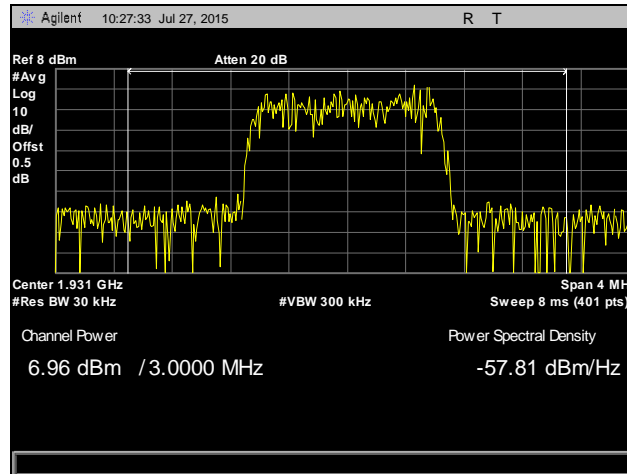

Plot 28. RF Power, Single Channel Operation – High Power, Input PCS1900 CDMA, Low Channel, Part 24

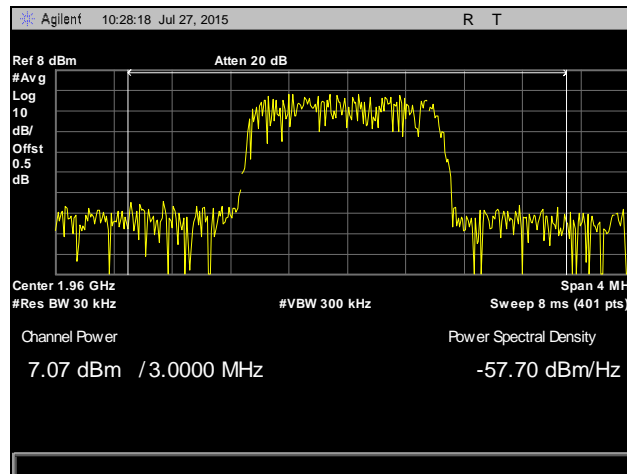

Plot 29. RF Power, Single Channel Operation – High Power, Input PCS1900 CDMA, Mid Channel, Part 24

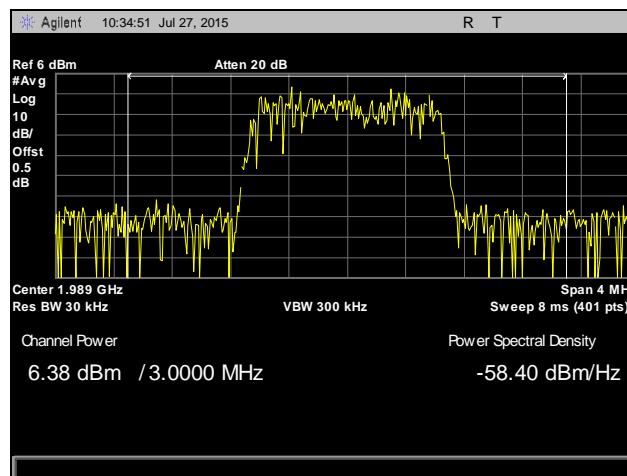

Plot 30. RF Power, Single Channel Operation – High Power, Input PCS1900 CDMA, High Channel, Part 24

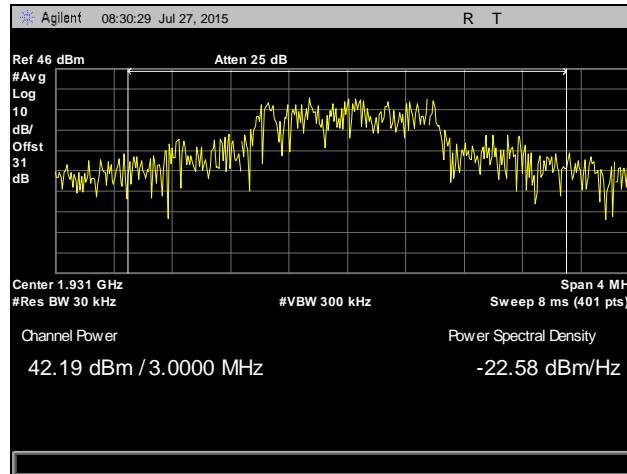

Plot 31. RF Power, Single Channel Operation – High Power, Output PCS1900 CDMA, Low Channel, Part 24

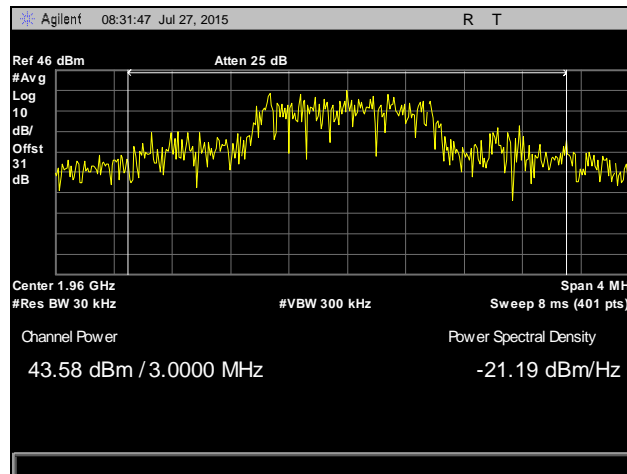

Plot 32. RF Power, Single Channel Operation – High Power, Output PCS1900 CDMA, Mid Channel, Part 24

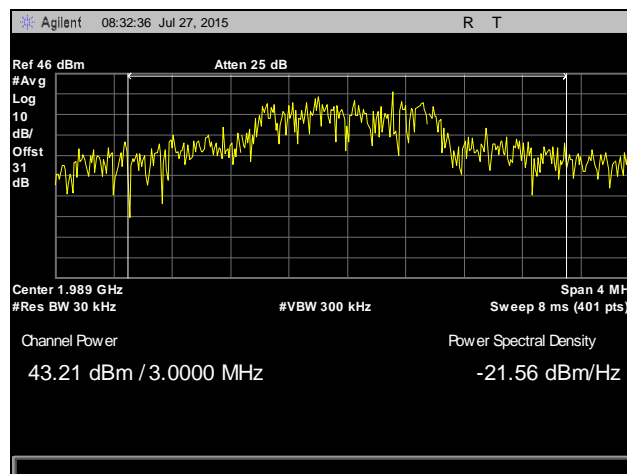

Plot 33. RF Power, Single Channel Operation – High Power, Output PCS1900 CDMA, High Channel, Part 24

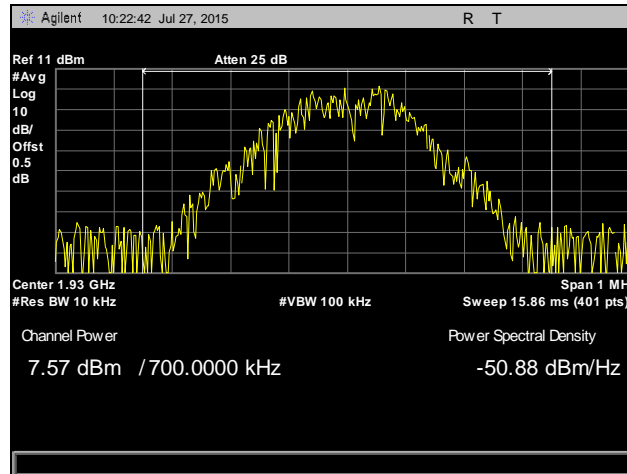

Plot 34. RF Power, Single Channel Operation – High Power, Input PCS1900, GSM, Low Channel, Part 24

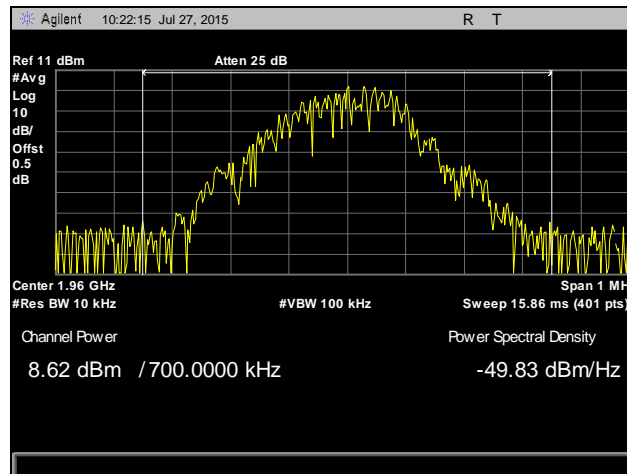

Plot 35. RF Power, Single Channel Operation – High Power, Input PCS1900, GSM, Mid Channel, Part 24

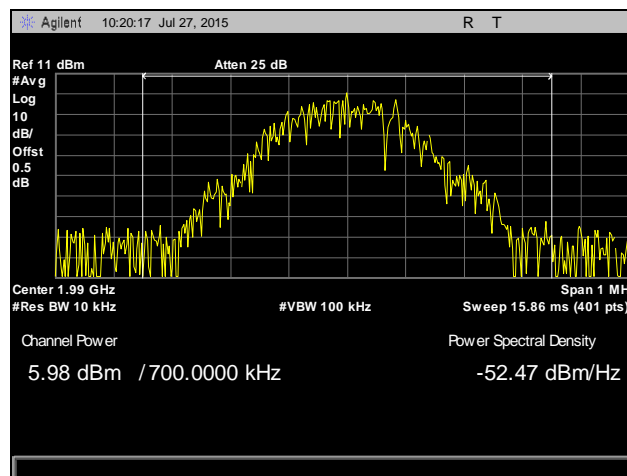

Plot 36. RF Power, Single Channel Operation – High Power, Input PCS1900, GSM, High Channel, Part 24

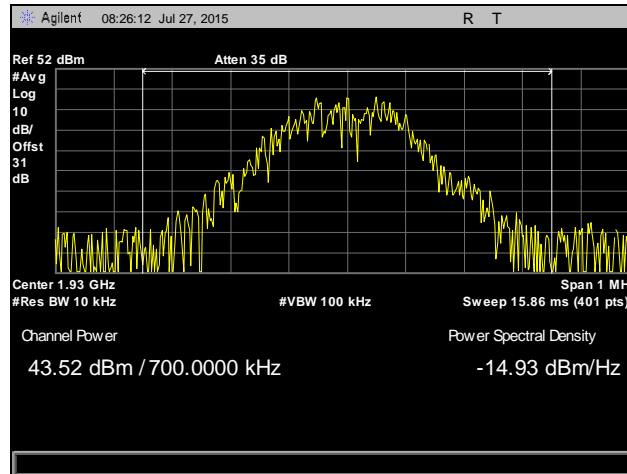

Plot 37. RF Power, Single Channel Operation – High Power, Output PCS1900, GSM, Low Channel, Part 24

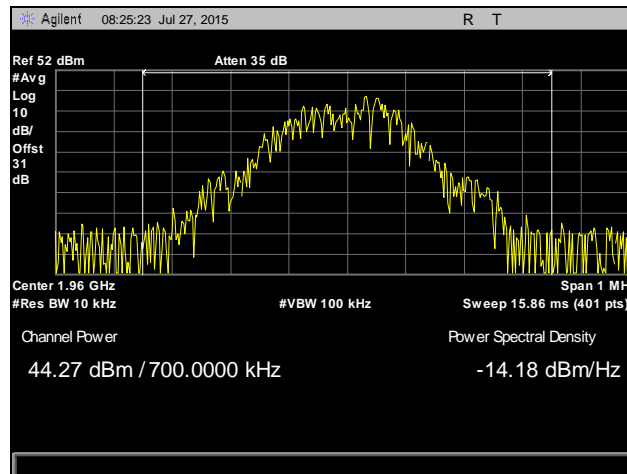

Plot 38. RF Power, Single Channel Operation – High Power, Output PCS1900, GSM, Mid Channel, Part 24

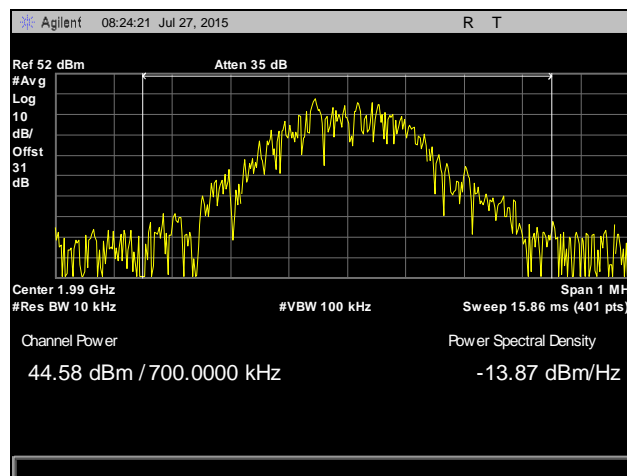

Plot 39. RF Power, Single Channel Operation – High Power, Output PCS1900, GSM, High Channel, Part 24

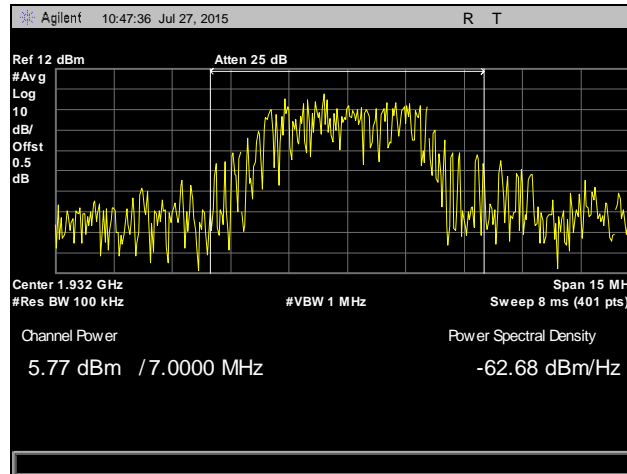

Plot 40. RF Power, Single Channel Operation – High Power, Input PCS1900 WCDMA, Low Channel, Part 24

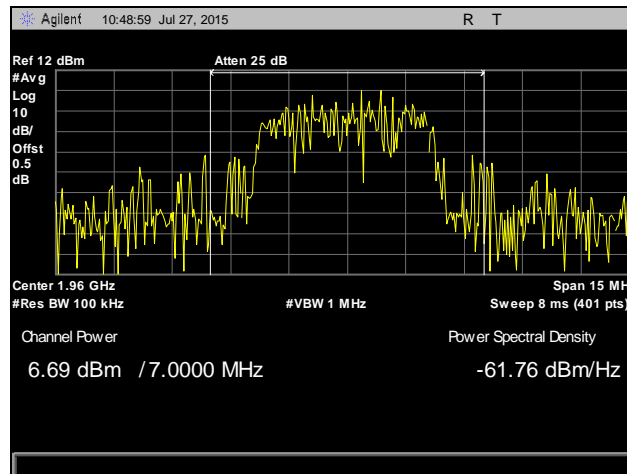

Plot 41. RF Power, Single Channel Operation – High Power, Input PCS1900 WCDMA, Mid Channel, Part 24

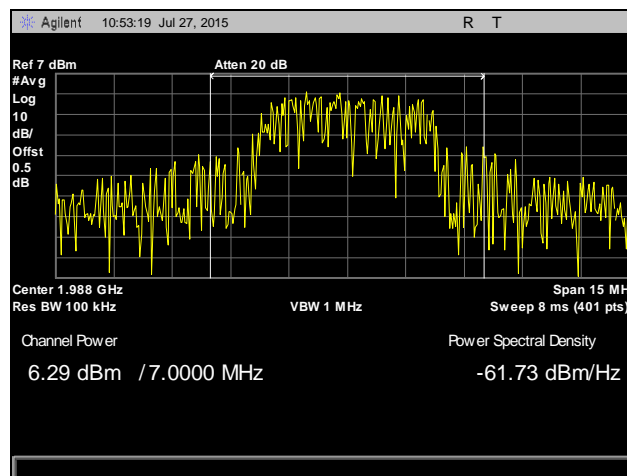

Plot 42. RF Power, Single Channel Operation – High Power, Input PCS1900 WCDMA, High Channel, Part 24

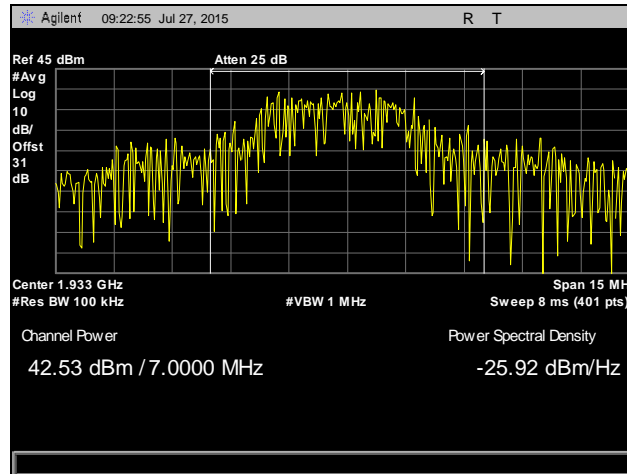

Plot 43. RF Power, Single Channel Operation – High Power, Output PCS1900 WCDMA, Low Channel, Part 24

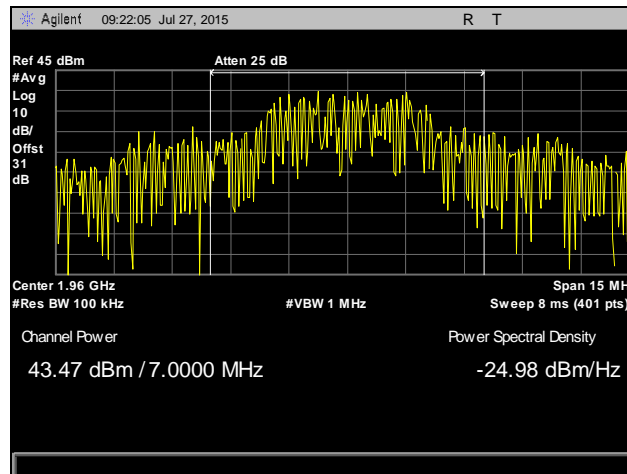

Plot 44. RF Power, Single Channel Operation – High Power, Output PCS1900 WCDMA, Mid Channel, Part 24

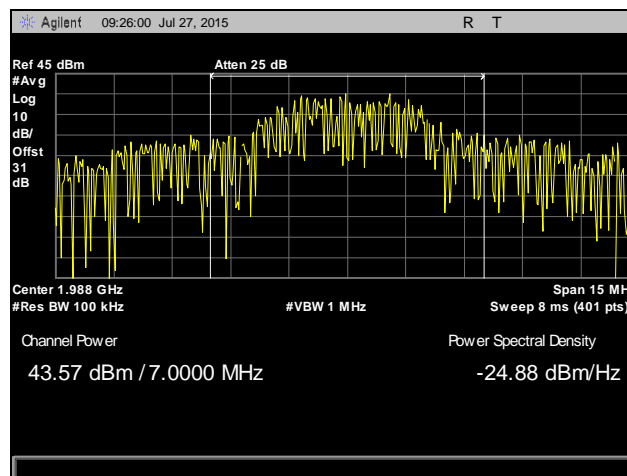

Plot 45. RF Power, Single Channel Operation – High Power, Output PCS1900 WCDMA, High Channel, Part 24

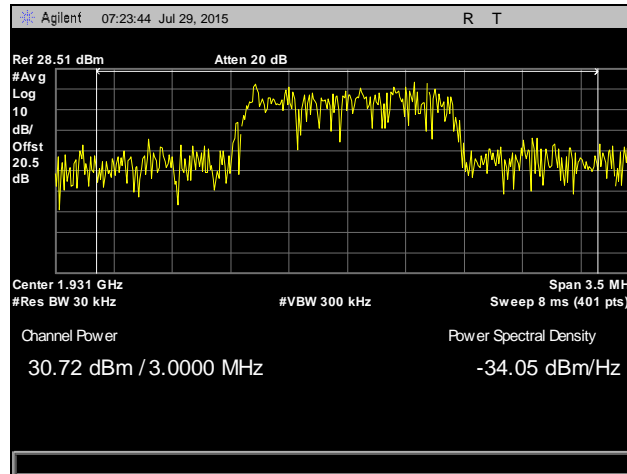

Plot 46. RF Power, Multi-Channel Operation – Reduced Power, Output PCS1900 CDMA, Low Channel, Part 24

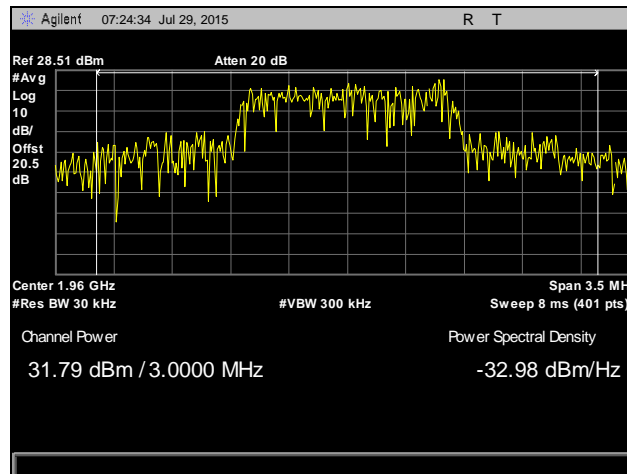

Plot 47. RF Power, Multi-Channel Operation – Reduced Power, Output PCS1900 CDMA, Mid Channel, Part 24

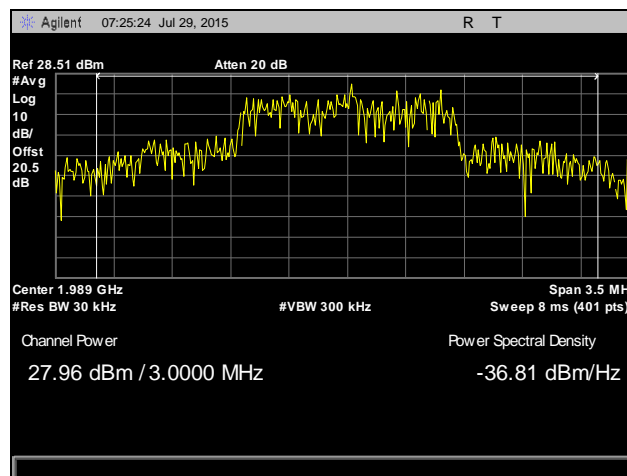

Plot 48. RF Power, Multi-Channel Operation – Reduced Power, Output PCS1900 CDMA, High Channel, Part 24

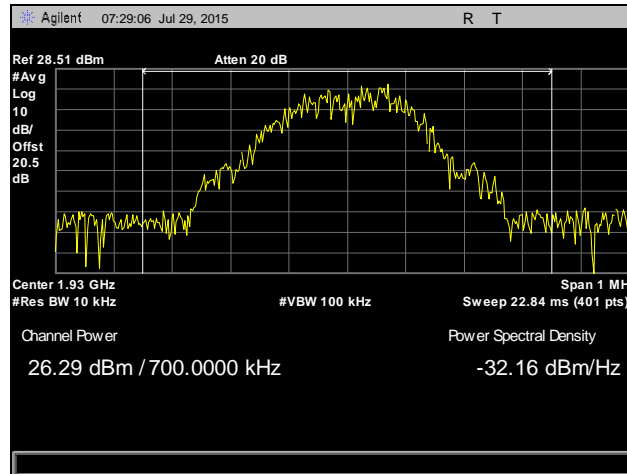

Plot 49. RF Power, Multi-Channel Operation – Reduced Power, Output PCS1900 GSM, Low Channel, Part 24

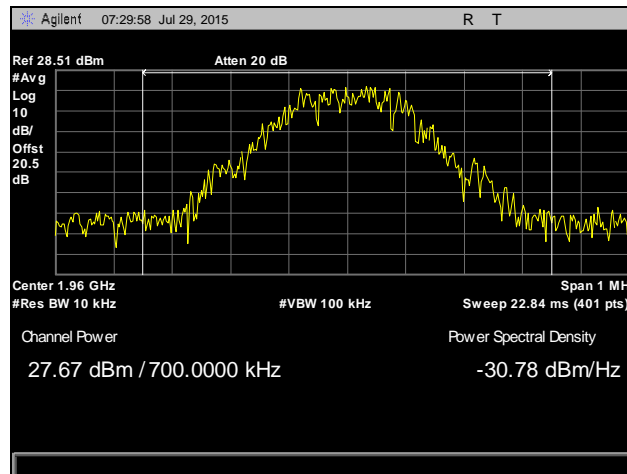

Plot 50. RF Power, Multi-Channel Operation – Reduced Power, Output PCS1900 GSM, Mid Channel, Part 24

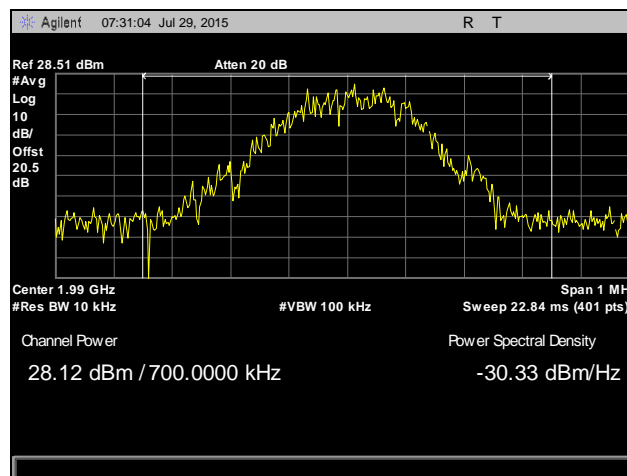

Plot 51. RF Power, Multi-Channel Operation – Reduced Power, Output PCS1900 GSM, High Channel, Part 24

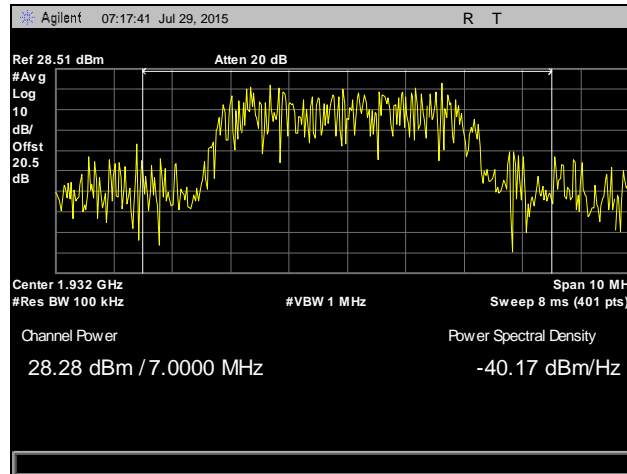

Plot 52. RF Power, Multi-Channel Operation – Reduced Power, Output PCS1900 WCDMA, Low Channel, Part 24

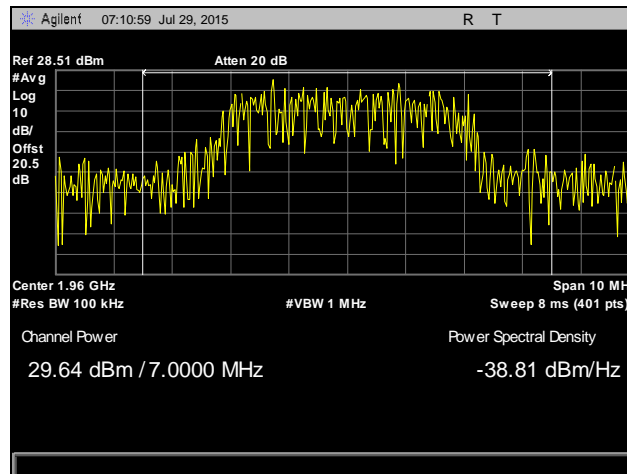

Plot 53. RF Power, Multi-Channel Operation – Reduced Power, Output PCS1900 WCDMA, Mid Channel, Part 24

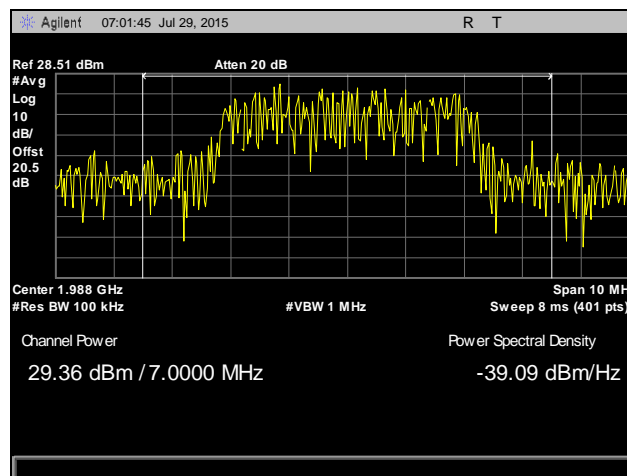

Plot 54. RF Power, Multi-Channel Operation – Reduced Power, Output PCS1900 WCDMA, High Channel, Part 24

§ 2.1049 Occupied Bandwidth

Test Requirement(s): § 2.1049 **Measurements required: Occupied bandwidth:** The occupied bandwidth, that is the frequency bandwidth such that, below its lower and above its upper frequency limits, the mean powers radiated are each equal to 0.5 percent of the total mean power radiated by a given emission shall be measured under the specified conditions of § 2.1049 (a) through (i) as applicable.

Test Procedures: As required by 47 CFR 2.1049, *occupied bandwidth measurements* were made at the RF output terminals using a Spectrum Analyzer.

A laptop was connected to EUT to control the RF frequency channel. The EUT was connected to a Spectrum Analyzer via attenuator. The RBW of the Spectrum Analyzer was set in accordance with the licensed measurement guidance procedures. Measurements were carried out at the low, mid, and high channels of the TX band.

Test Results: Equipment complies with FCC requirements.

Test Engineer(s): Benjamin Taylor

Test Date(s): 08/06/15

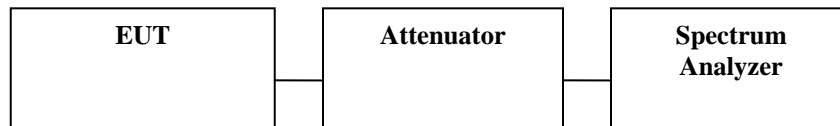
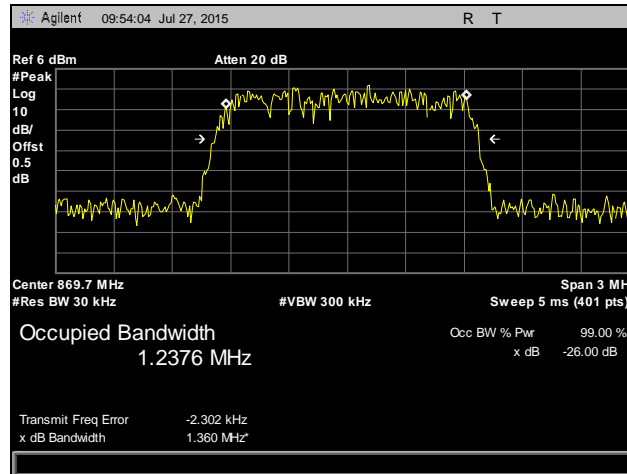
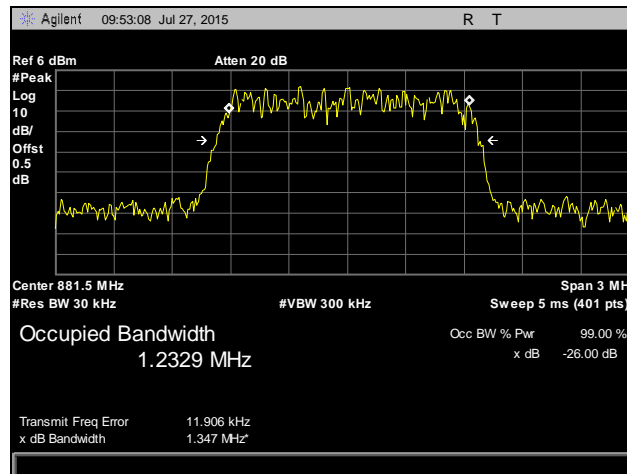

Figure 2. Occupied Bandwidth Test Setup



Plot 55. Occupied Bandwidth, CDMA, Low Channel, Input, Part 22



Plot 56. Occupied Bandwidth, CDMA, Mid Channel, Input, Part 22

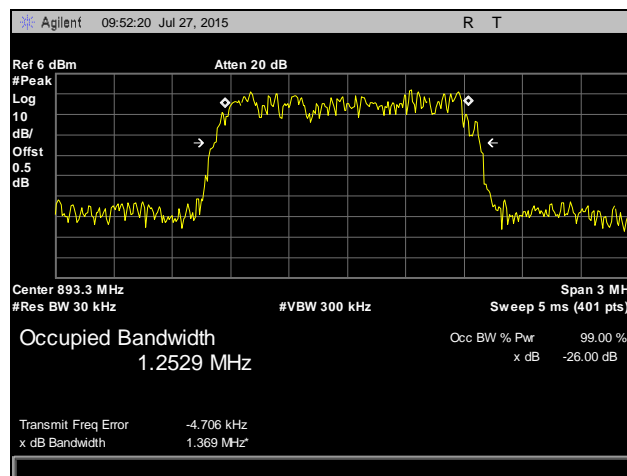

Plot 57. Occupied Bandwidth, CDMA, High Channel, Input, Part 22

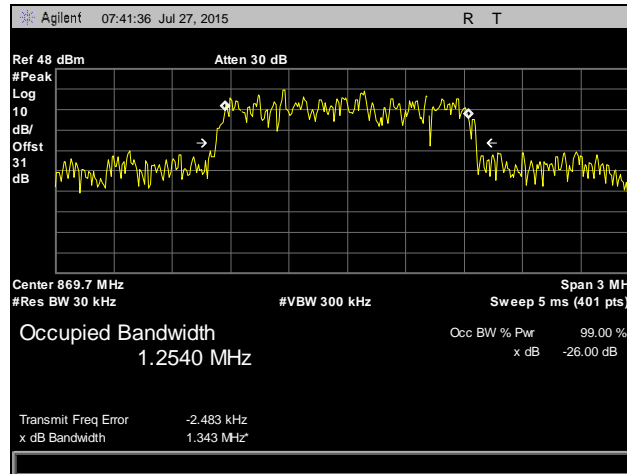

Plot 58. Occupied Bandwidth, CDMA, Low Channel, Output, Part 22

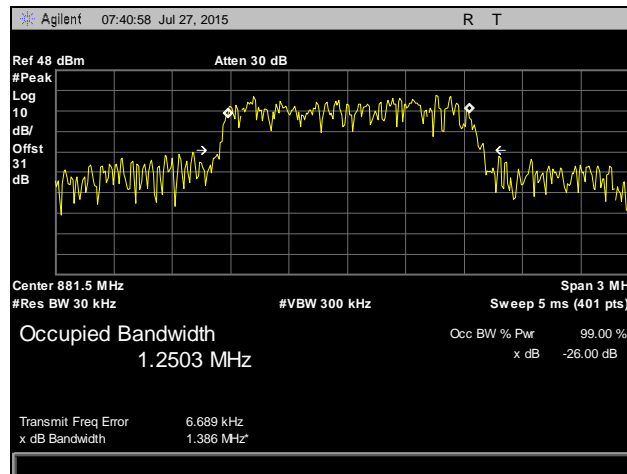

Plot 59. Occupied Bandwidth, CDMA, Mid Channel, Output, Part 22

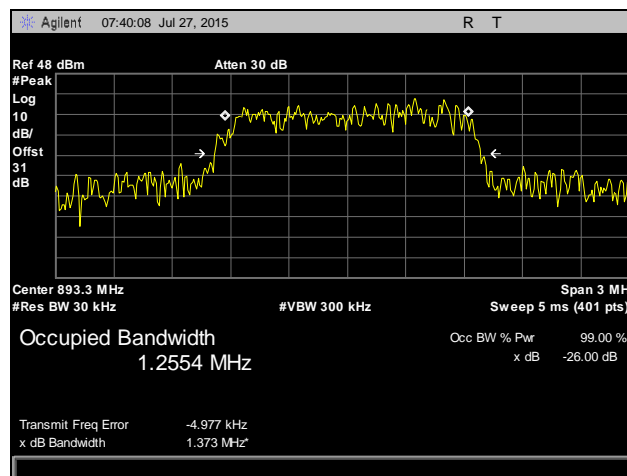

Plot 60. Occupied Bandwidth, CDMA, High Channel, Output, Part 22

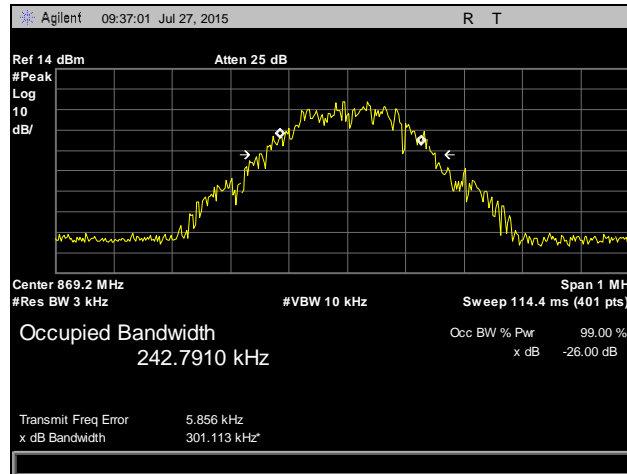

Plot 61. Occupied Bandwidth, GSM, Low Channel, Input, Part 22

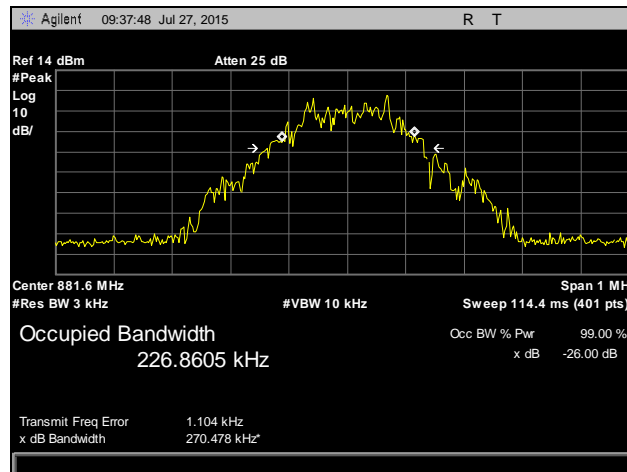

Plot 62. Occupied Bandwidth, GSM, Mid Channel, Input, Part 22

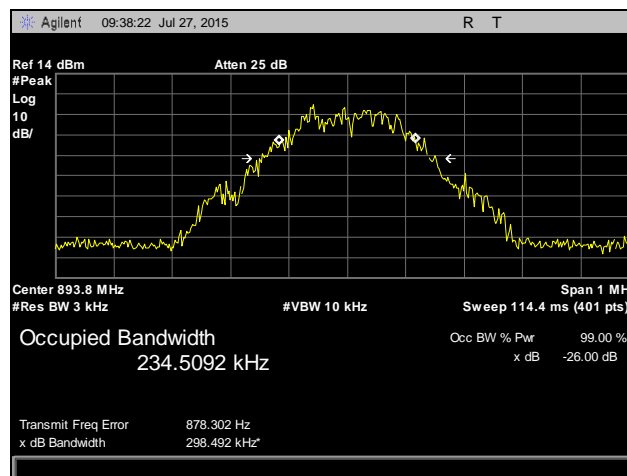

Plot 63. Occupied Bandwidth, GSM, High Channel, Input, Part 22

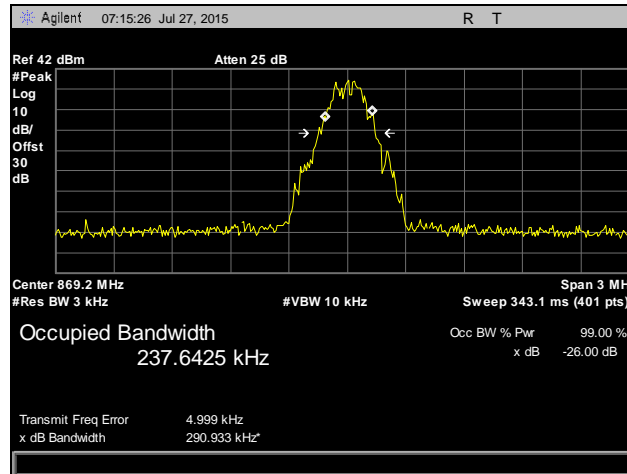

Plot 64. Occupied Bandwidth, GSM, Low Channel, Output, Part 22

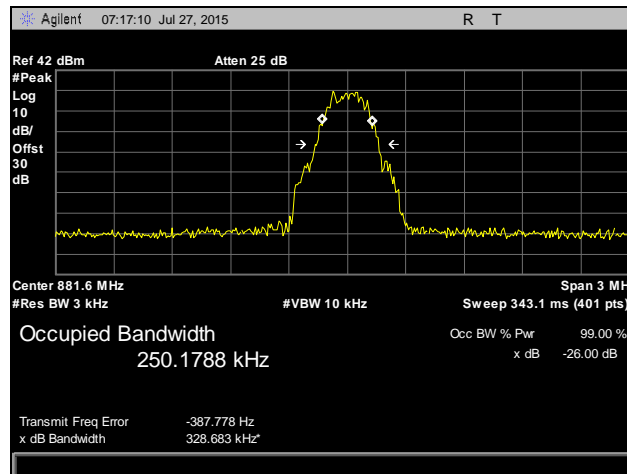

Plot 65. Occupied Bandwidth, GSM, Mid Channel, Output, Part 22

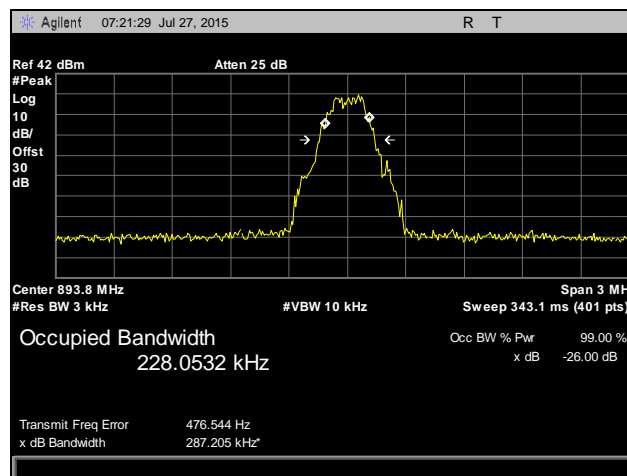

Plot 66. Occupied Bandwidth, GSM, High Channel, Output, Part 22

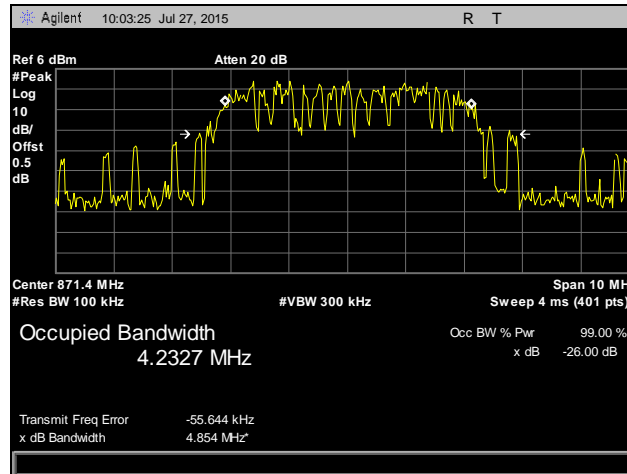

Plot 67. Occupied Bandwidth, WCDMA, Low Channel, Input, Part 22

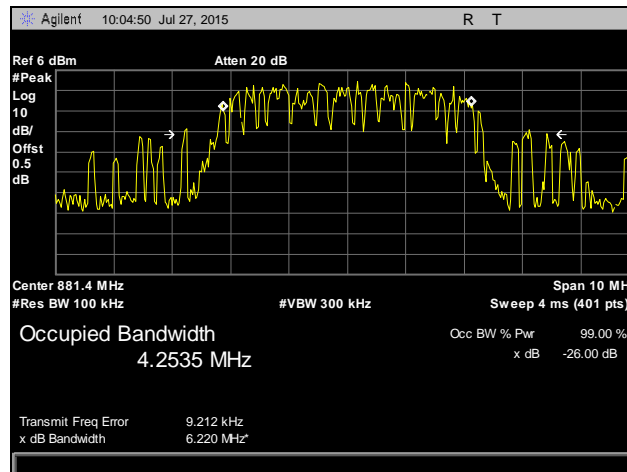

Plot 68. Occupied Bandwidth, WCDMA, Mid Channel, Input, Part 22

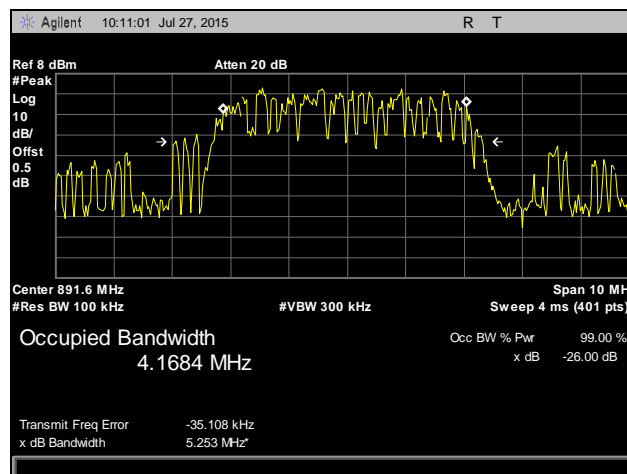

Plot 69. Occupied Bandwidth, WCDMA, High Channel, Input, Part 22

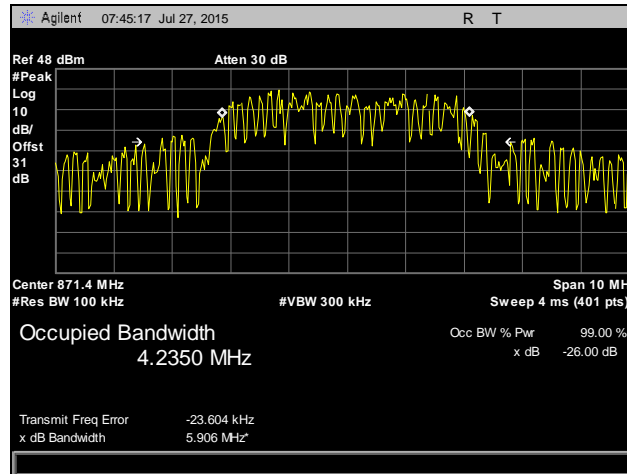

Plot 70. Occupied Bandwidth, WCDMA, Low Channel, Output, Part 22

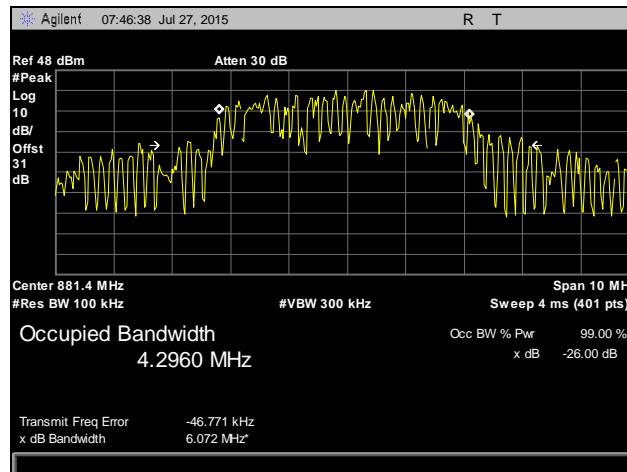

Plot 71. Occupied Bandwidth, WCDMA, Mid Channel, Output, Part 22

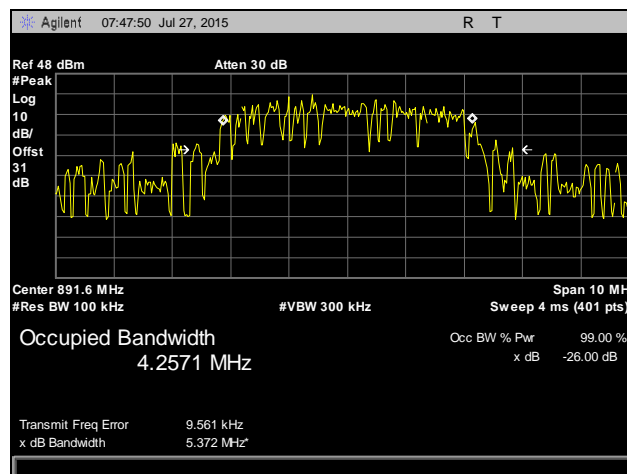

Plot 72. Occupied Bandwidth, WCDMA, High Channel, Output, Part 22

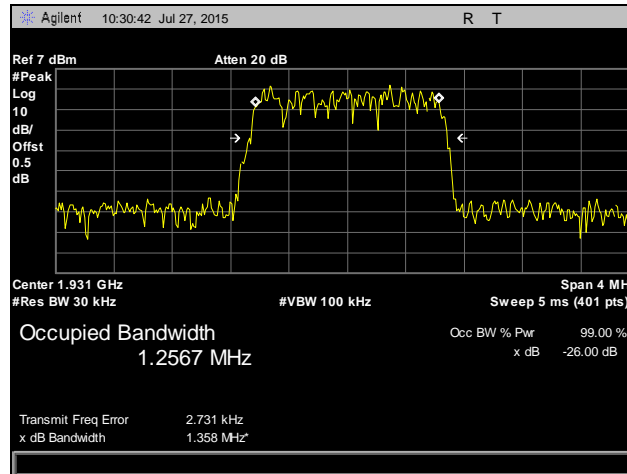

Plot 73. Occupied Bandwidth, PCS1900 CDMA, Low Channel, Input, Part 24

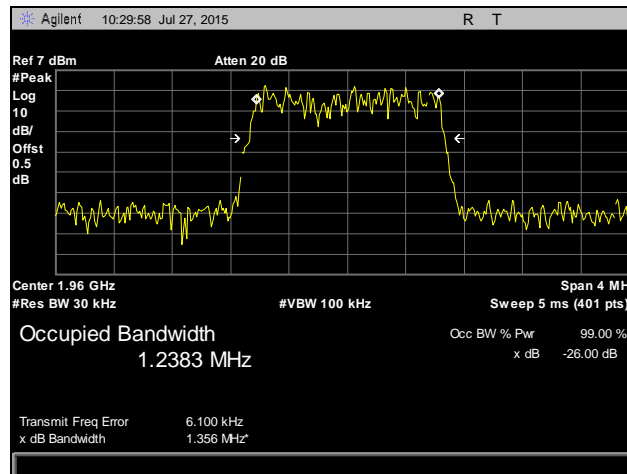

Plot 74. Occupied Bandwidth, PCS1900 CDMA, Mid Channel, Input, Part 24

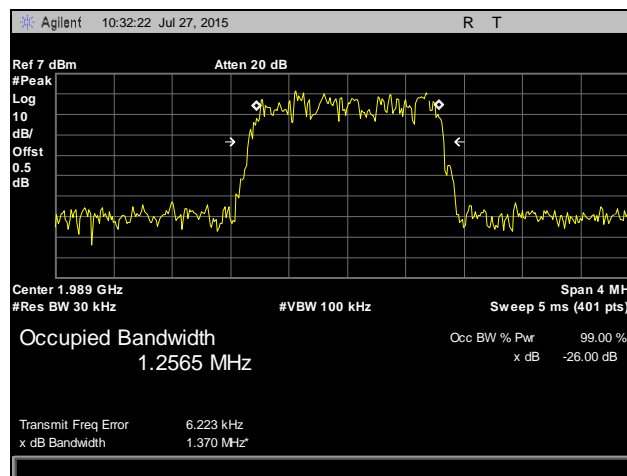

Plot 75. Occupied Bandwidth, PCS1900 CDMA, High Channel, Input, Part 24

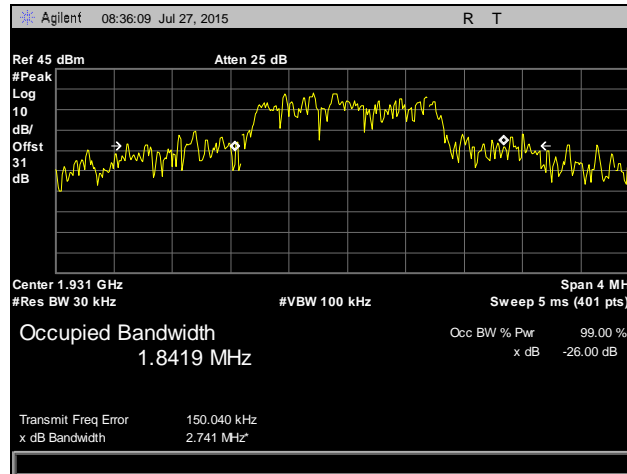

Plot 76. Occupied Bandwidth, PCS1900 CDMA, Low Channel, Output, Part 24

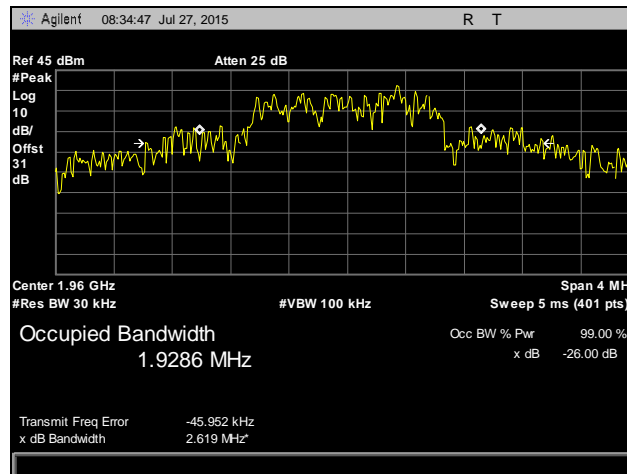

Plot 77. Occupied Bandwidth, PCS1900 CDMA, Mid Channel, Output, Part 24

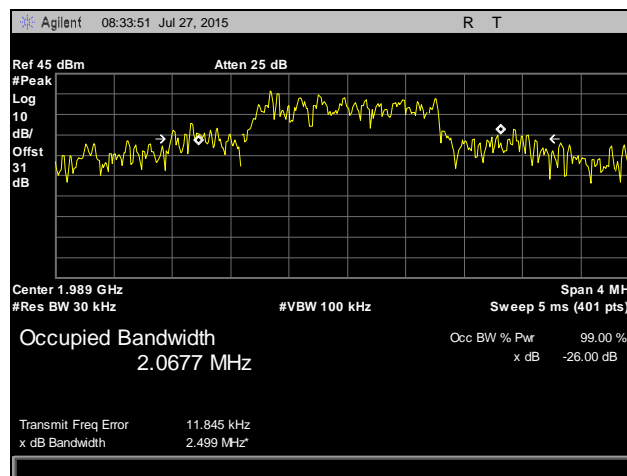

Plot 78. Occupied Bandwidth, PCS1900 CDMA, High Channel, Output, Part 24

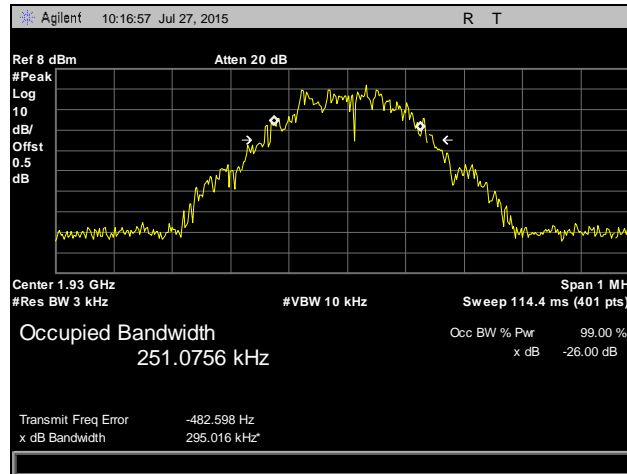

Plot 79. Occupied Bandwidth, PCS1900 GSM, Low Channel, Input, Part 24

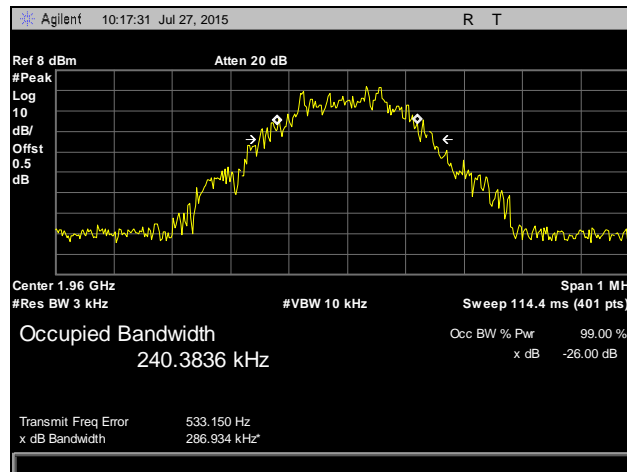

Plot 80. Occupied Bandwidth, PCS1900 GSM, Mid Channel, Input, Part 24

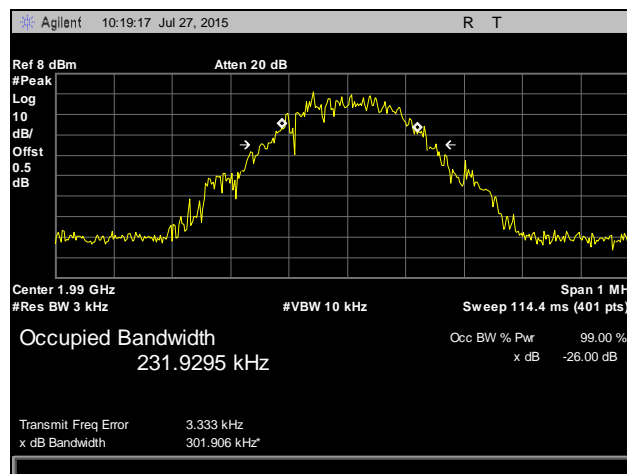

Plot 81. Occupied Bandwidth, PCS1900 GSM, High Channel, Input, Part 24

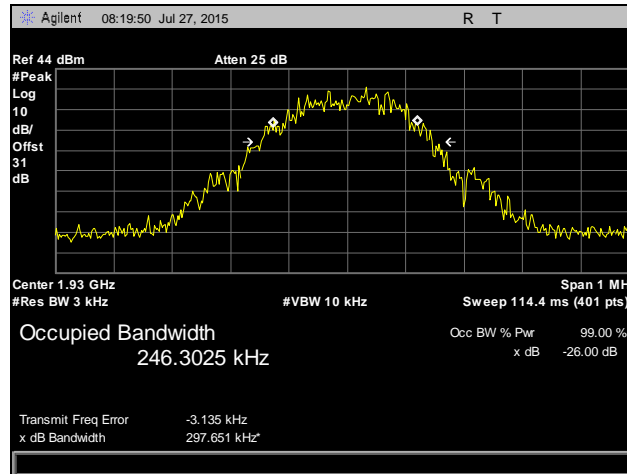

Plot 82. Occupied Bandwidth, PCS1900 GSM, Low Channel, Output, Part 24

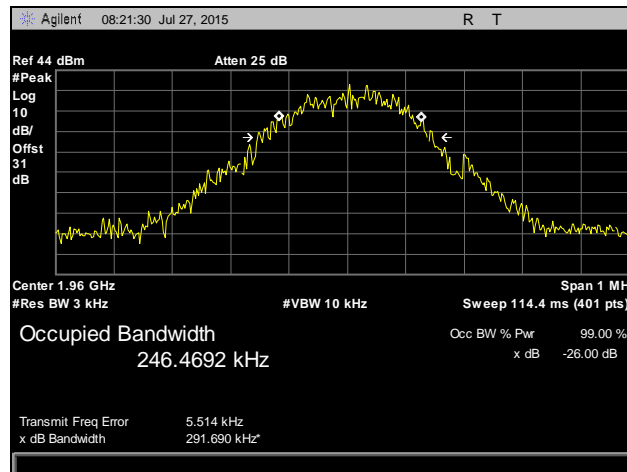

Plot 83. Occupied Bandwidth, PCS1900 GSM, Mid Channel, Output, Part 24

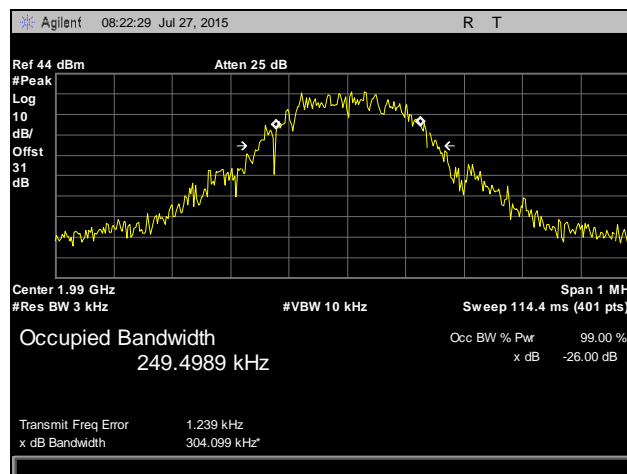

Plot 84. Occupied Bandwidth, PCS1900 GSM, High Channel, Output, Part 24

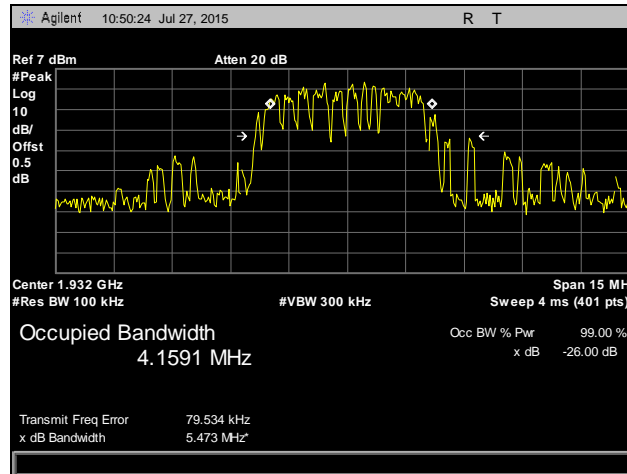

Plot 85. Occupied Bandwidth, PCS1900 WCDMA, Low Channel, Input, Part 24

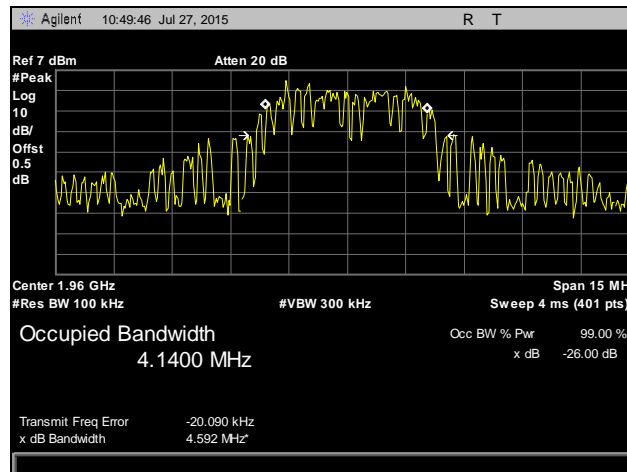

Plot 86. Occupied Bandwidth, PCS1900 WCDMA, Mid Channel, Input, Part 24

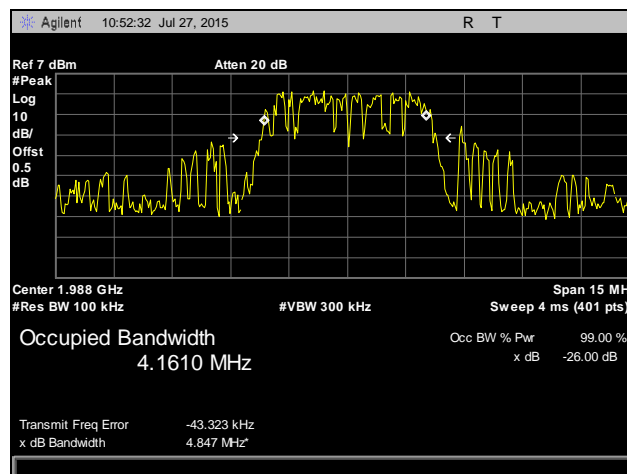

Plot 87. Occupied Bandwidth, PCS1900 WCDMA, High Channel, Input, Part 24

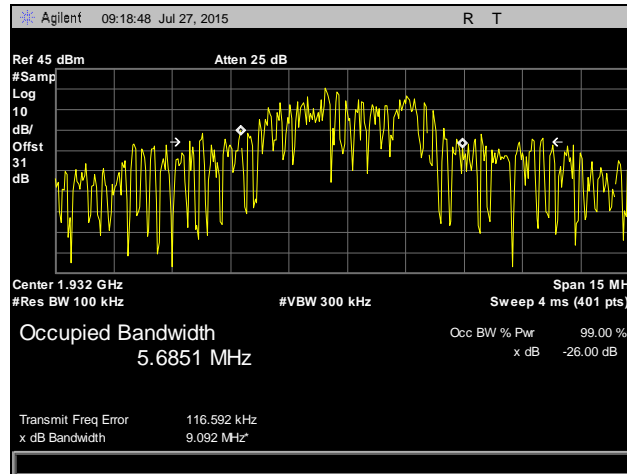

Plot 88. Occupied Bandwidth, PCS1900 WCDMA, Low Channel, Output, Part 24

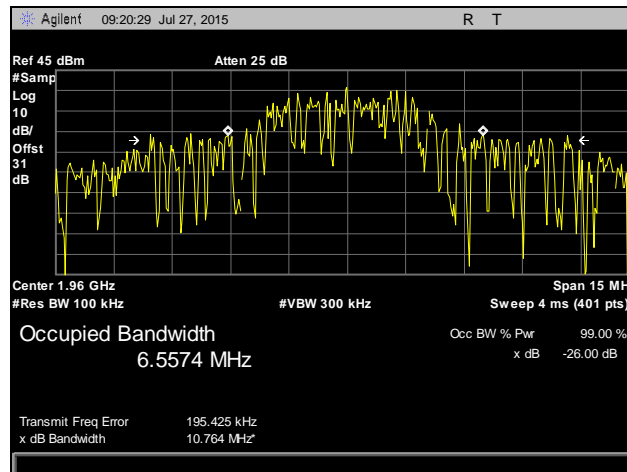

Plot 89. Occupied Bandwidth, PCS1900 WCDMA, Mid Channel, Output, Part 24

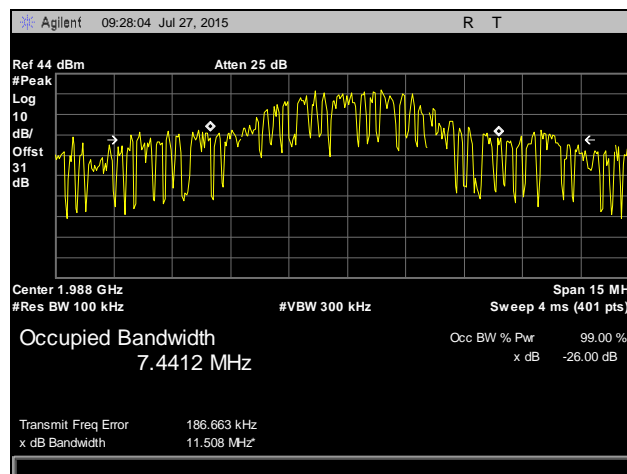

Plot 90. Occupied Bandwidth, PCS1900 WCDMA, High Channel, Output, Part 24



Electromagnetic Compatibility Criteria for Intentional Radiators

§ 2.1053 Radiated Spurious Emissions

Test Requirement(s): § 2.1053 Measurements required: Field strength of spurious radiation.

§ 2.1053 (a) Measurements shall be made to detect spurious emissions that may be radiated directly from the cabinet, control circuits, power leads, or intermediate circuit elements under normal conditions of installation and operation. Curves or equivalent data shall be supplied showing the magnitude of each harmonic and other spurious emission. For this test, single sideband, independent sideband, and controlled carrier transmitters shall be modulated under the conditions specified in paragraph (c) of § 2.1049, as appropriate. For equipment operating on frequencies below 890 MHz, an open field test is normally required with the measuring instrument antenna located in the far-field at all test frequencies. In the event it is either impractical or impossible to make open field measurements (e.g. a broadcast transmitter installed in a building) measurements will be accepted of the equipment as installed. Such measurements must be accompanied by a description of the site where the measurements were made showing the location of any possible source of reflections which might distort the field strength measurements. Information submitted shall include the relative radiated power of each spurious emission with reference to the rated power output of the transmitter, assuming all emissions are radiated from half-wave dipole antennas.

§ 2.1053 (b): The measurements specified in paragraph (a) of this section shall be made for the following equipment:

- (1) Those in which the spurious emissions are required to be 60 dB or more below the mean power of the transmitter.
- (2) All equipment operating on frequencies higher than 25 MHz.
- (3) All equipment where the antenna is an integral part of, and attached directly to the transmitter.
- (4) Other types of equipment as required, when deemed necessary by the Commission.

§ 22.917 **Emission limitations Cellular equipment:** The rules in this section govern the spectral characteristics of emissions in the Cellular Radiotelephone Service.

§ 22.917 (a): Out of band emissions. The power of any emission outside of the authorized operating frequency ranges must be attenuated below the transmitting power (P) by a factor of at least $43 + 10 \log(P)$.



Test Procedures: As required by 47 CFR 2.1053, *field strength of radiated spurious measurements* was made in accordance with the procedures of TIA/EIA-603-A-2001 "Land Mobile FM or PM Communications Equipment Measurement and Performance Standards".

Radiated emission measurements were performed inside a 3 meter semi-anechoic chamber. The EUT's RF ports were terminated to 50ohm load. The EUT was tested using both modulations and at the low, mid, and high channels. The EUT was rotated about 360⁰ and the receiving antenna scanned from 1-4m in order to capture the maximum emission. The plots are corrected for cable loss, antenna correction factor, and distance correction. The field strength was mathematically corrected to an E.I.R.P. Harmonic emissions up to the 10th or 40GHz, whichever was the lesser, were investigated.

The spectrum analyzer was set to 1MHz RBW and 3MHz VBW. The spectrum was investigated from 30MHz to the 10th harmonic of the carrier.

Test Results: The EUT complies with the requirements of this section.

Test Engineer: Benjamin Taylor

Test Date(s): 08/06/15



Radiated Spurious Emissions, Part 22

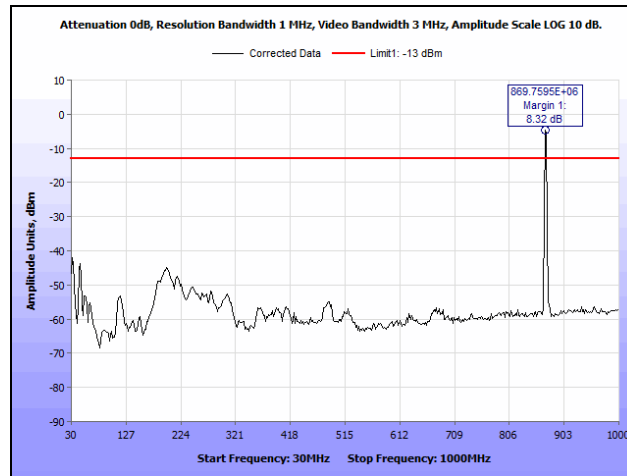

Plot 91. Radiated Spurious Emissions, Low Channel, 30 MHz – 1 GHz, Part 22

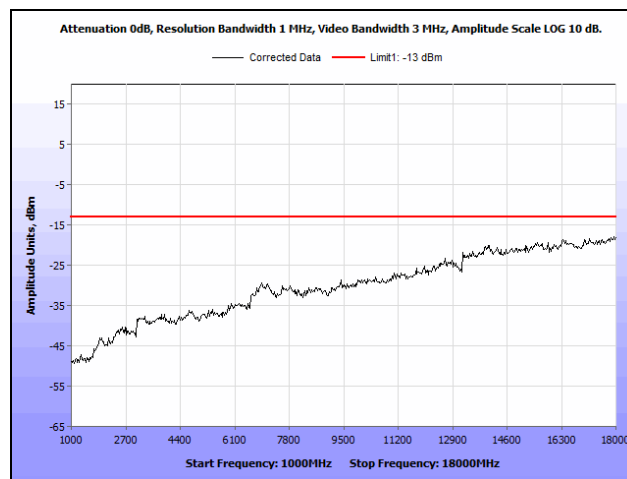

Plot 92. Radiated Spurious Emissions, Low Channel, 1 GHz – 18 GHz, Part 22

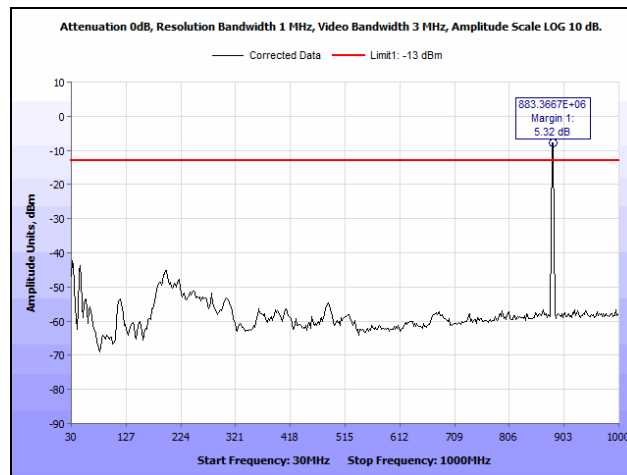

Plot 93. Radiated Spurious Emissions, Mid Channel, 30 MHz – 1 GHz, Part 22

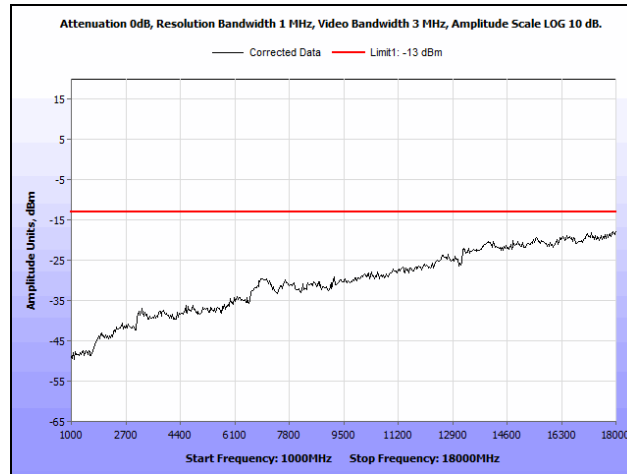

Plot 94. Radiated Spurious Emissions, Mid Channel, 1 GHz – 18 GHz, Part 22

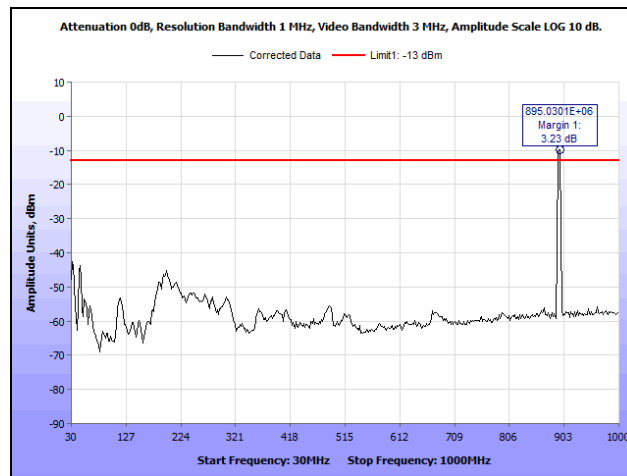

Plot 95. Radiated Spurious Emissions, High Channel, 30 MHz – 1 GHz, Part 22

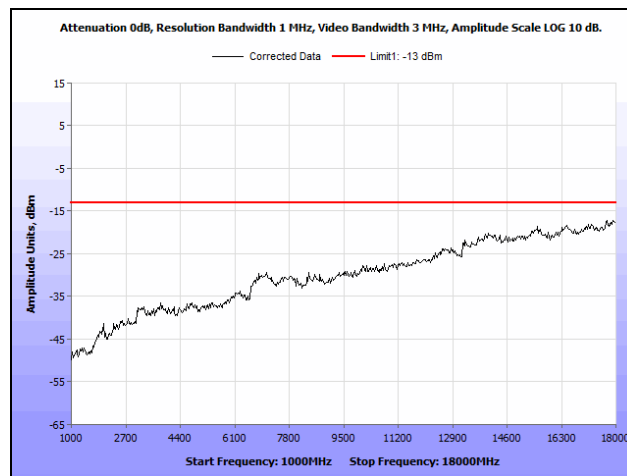

Plot 96. Radiated Spurious Emissions, High Channel, 1 GHz – 18 GHz, Part 22



Radiated Spurious Emissions, Part 24

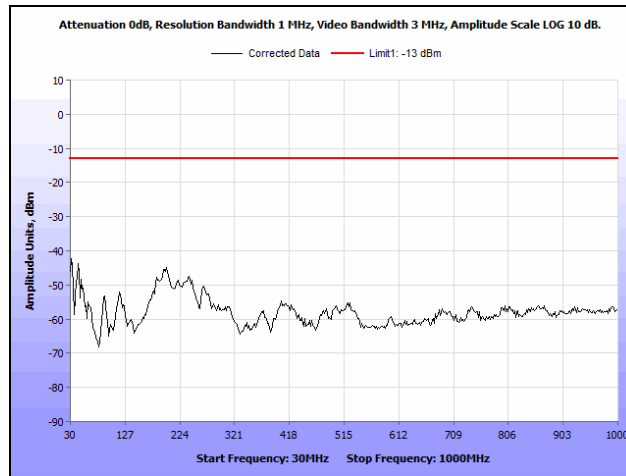

Plot 97. Radiated Spurious Emissions, Low Channel, 30 MHz – 1 GHz, Part 24

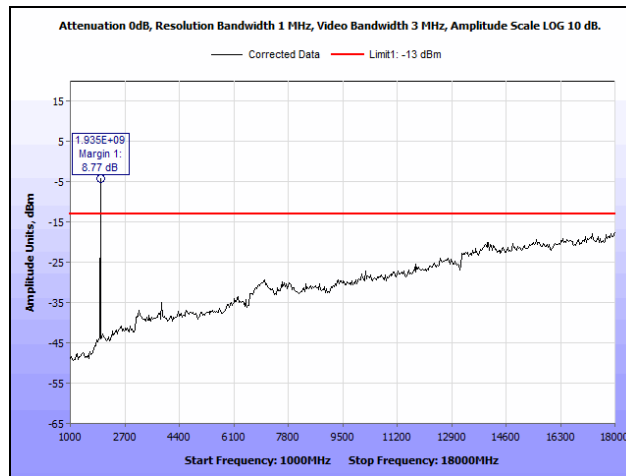

Plot 98. Radiated Spurious Emissions, Low Channel, 1 GHz – 18 GHz, Part 24

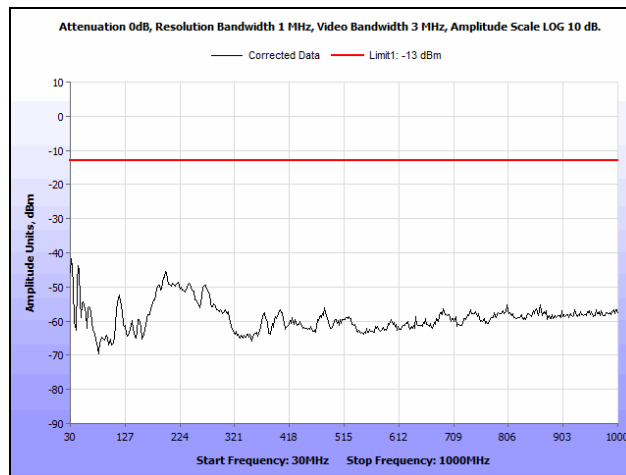

Plot 99. Radiated Spurious Emissions, Mid Channel, 30 MHz – 1 GHz, Part 24

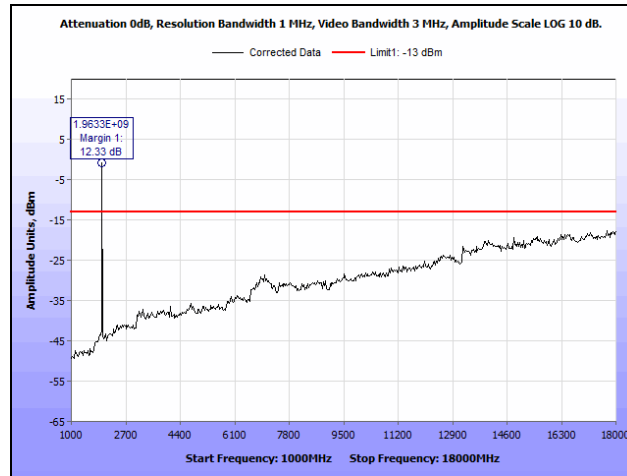

Plot 100. Radiated Spurious Emissions, Mid Channel, 1 GHz – 18 GHz, Part 24

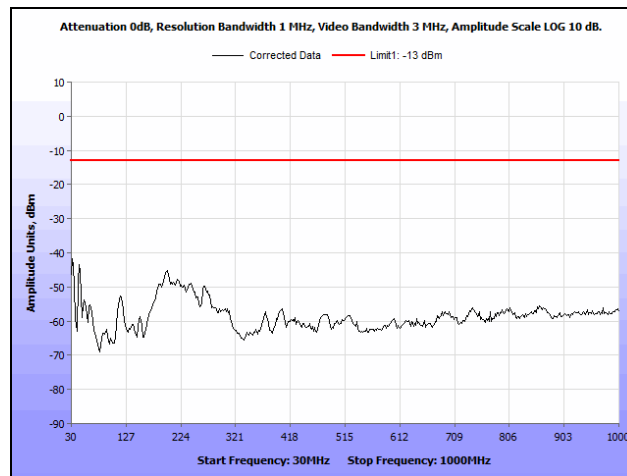

Plot 101. Radiated Spurious Emissions, High Channel, 30 MHz – 1 GHz, Part 24

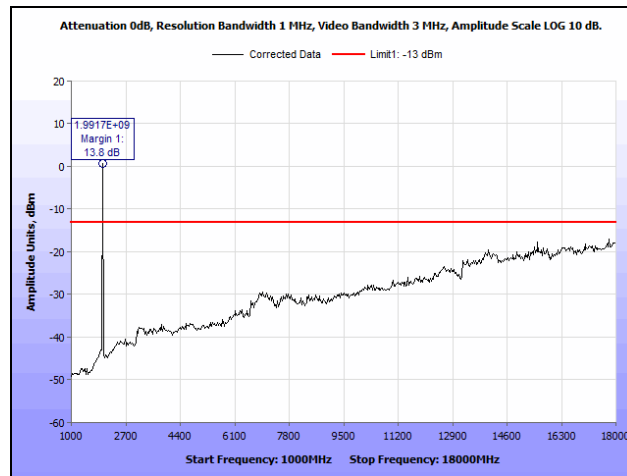

Plot 102. Radiated Spurious Emissions, High Channel, 1 GHz – 18 GHz, Part 24



Electromagnetic Compatibility Criteria for Intentional Radiators

§ 2.1051 Spurious Emissions at Antenna Terminals

Test Requirement(s): § 2.1051 **Measurements required: Spurious emissions at antenna terminals:** The radio frequency voltage or powers generated within the equipment and appearing on a spurious frequency shall be checked at the equipment output terminals when properly loaded with a suitable artificial antenna. Curves or equivalent data shall show the magnitude of each harmonic and other spurious emission that can be detected when the equipment is operated under the conditions specified in § 2.1049 as appropriate. The magnitude of spurious emissions which are attenuated more than 20 dB below the permissible value need not be specified.

§ 22.917 The rules in this section govern the spectral characteristics of emissions in the Cellular Radiotelephone Service.

§ 22.917 (a) Out of band emissions. The power of any emission outside of the authorized operating frequency ranges must be attenuated below the transmitting power (P) by a factor of at least $43 + 10 \log(P)$ dB.

§ 22.917 (b) *Measurement procedure.* Compliance with these rules is based on the use of measurement instrumentation employing a resolution bandwidth of 30 kHz or more. In the 60 kHz bands immediately outside and adjacent to the authorized frequency range or channel, a resolution bandwidth of at least one percent of the emission bandwidth of the fundamental emission of the transmitter may be employed. A narrower resolution bandwidth is permitted in all cases to improve measurement accuracy approved the measured power is integrated over the full required measurement bandwidth (i.e., 30 kHz or 1 percent of emission bandwidth, as specified). The emission bandwidth is defined as the width of the signal between two points, one below the carrier center frequency and one above the carrier center frequency, outside of which all emissions are attenuated at least 26 dB below the transmitter power.

§24.238 **Emission limitations for Broadband PCS equipment:** The rules in this section govern the spectral characteristics of emissions in the Broadband Personal Communications Service.

§ 24.238 (a) Out of band emissions. The power of any emission outside of the authorized operating frequency ranges must be attenuated below the transmitting power (P) by a factor of at least $43 + 10 \log(P)$ dB.

§ 24.238 (b) *Measurement procedure.* Compliance with these rules is based on the use of measurement instrumentation employing a resolution bandwidth of 1 MHz or greater. However, in the 1 MHz bands immediately outside and adjacent to the frequency block a resolution bandwidth of at least one percent of the emission bandwidth of the fundamental emission of the transmitter may be employed. A narrower resolution bandwidth is permitted in all cases to improve measurement accuracy provided the measured power is integrated over the full required measurement bandwidth (i.e., 1 MHz or 1 percent of emission bandwidth, as specified). The emission bandwidth is defined as the width of the signal between two points, one below the carrier center frequency and one above the carrier center frequency, outside of which all emissions are attenuated at least 26 dB below the transmitter power.

Test Procedures: As required by 47 CFR §2.1051, *spurious emissions at antenna terminal measurements* were made at the RF output terminals using a Spectrum Analyzer.

A laptop was connected to EUT to control the RF power output and frequency channel. The EUT was connected to a Spectrum Analyzer through an attenuator. The Spectrum Analyzer was set to sweep 30 MHz and up to 10th harmonic of the fundamental or 40 GHz whichever is the lesser. Measurements were made in all applicable frequency bands.

Band Edge Plots: If a reduction of power was necessary for compliance at band edges, a second band edge plot was taken at the outermost channel that was compliant at the highest power. The channel number is noted in the caption of those plots.

Test Results: Equipment complies with these requirements.

Test Engineer(s): Benjamin Taylor

Test Date(s): 08/06/15

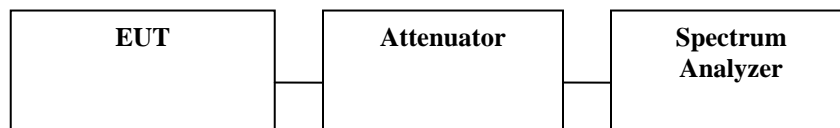
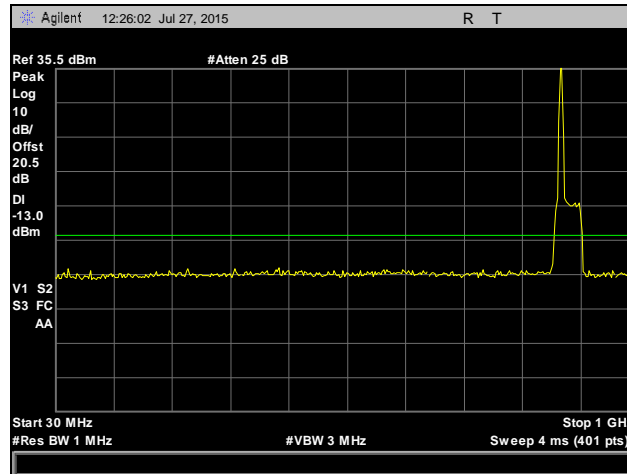
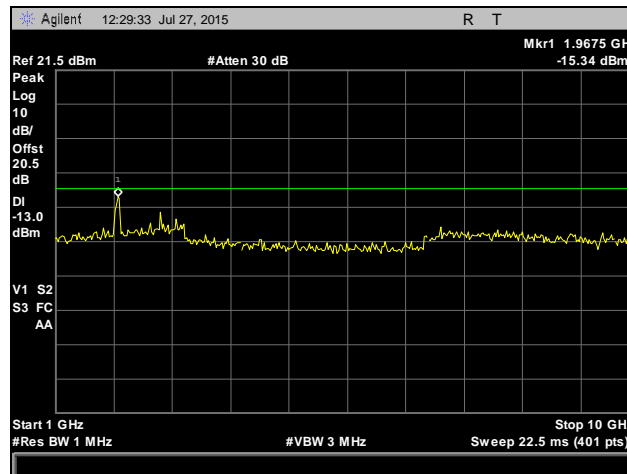

Figure 3. Spurious Emissions at Antenna Terminals Test Setup



Plot 103. Conducted Spurious Emissions, CDMA, Low Channel, 30 MHz – 1 GHz, Part 22



Plot 104. Conducted Spurious Emissions, CDMA, Low Channel, 1 GHz – 10 GHz, Part 22

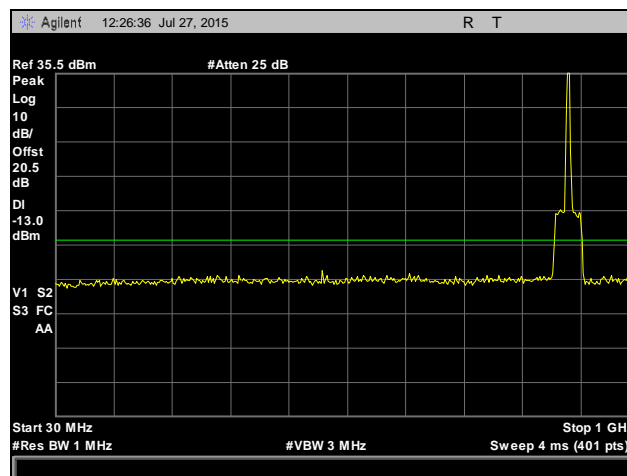

Plot 105. Conducted Spurious Emissions, CDMA, Mid Channel, 30 MHz – 1 GHz, Part 22

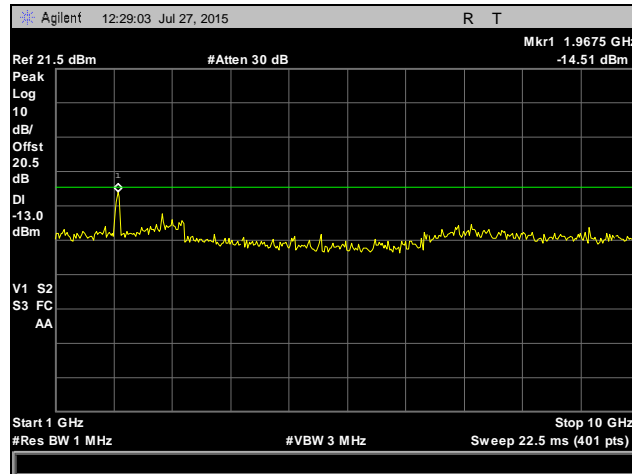

Plot 106. Conducted Spurious Emissions, CDMA, Mid Channel, 1 GHz – 10 GHz, Part 22

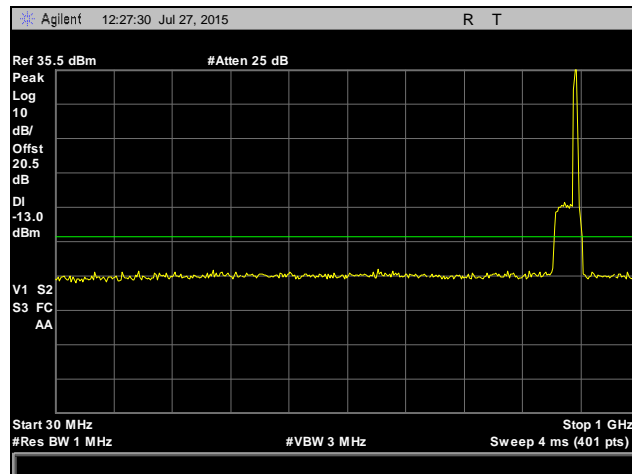

Plot 107. Conducted Spurious Emissions, CDMA, High Channel, 30 MHz – 1 GHz, Part 22

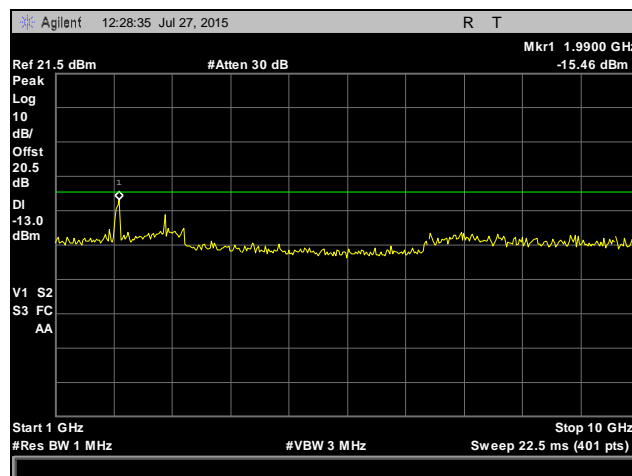

Plot 108. Conducted Spurious Emissions, CDMA, High Channel, 1 GHz – 10 GHz, Part 22

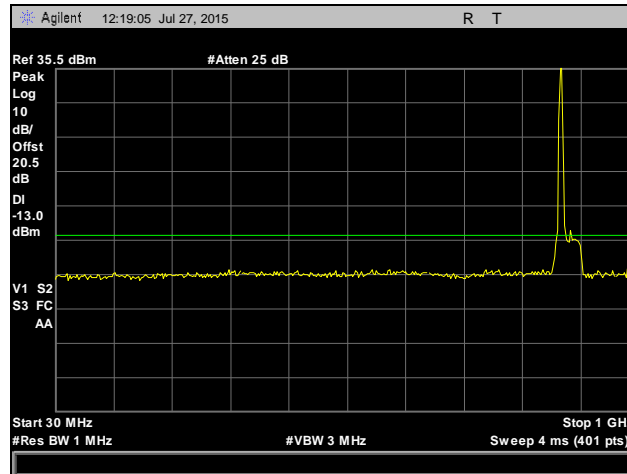

Plot 109. Conducted Spurious Emissions, GSM, Low Channel, 30 MHz – 1 GHz, Part 22

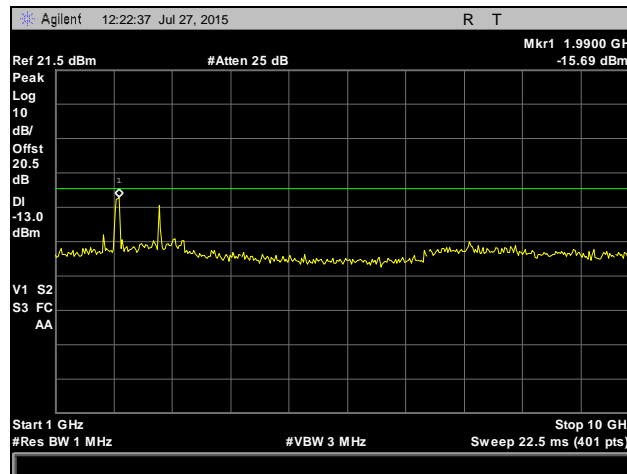

Plot 110. Conducted Spurious Emissions, GSM, Low Channel, 1 GHz – 10 GHz, Part 22

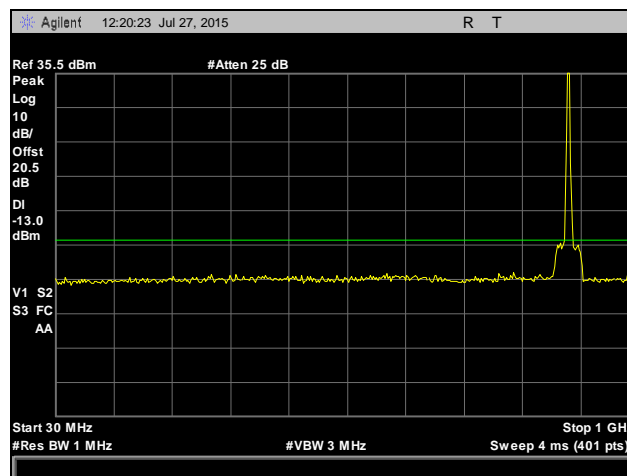

Plot 111. Conducted Spurious Emissions, GSM, Mid Channel, 30 MHz – 1 GHz, Part 22

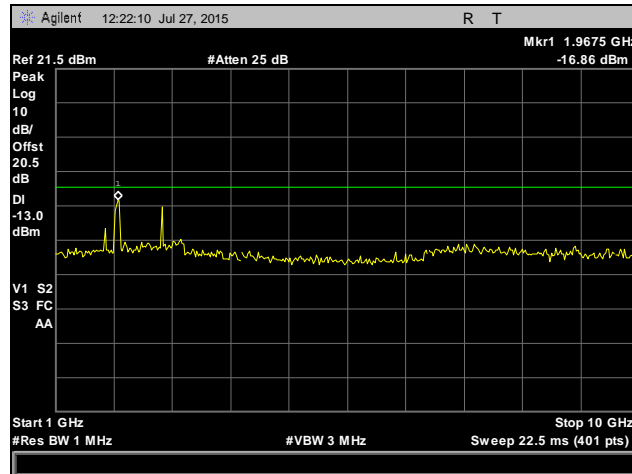

Plot 112. Conducted Spurious Emissions, GSM, Mid Channel, 1 GHz – 10 GHz, Part 22

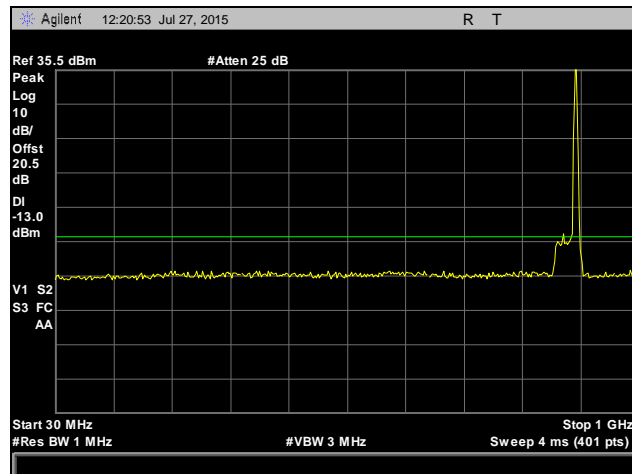

Plot 113. Conducted Spurious Emissions, GSM, High Channel, 30 MHz – 1 GHz, Part 22

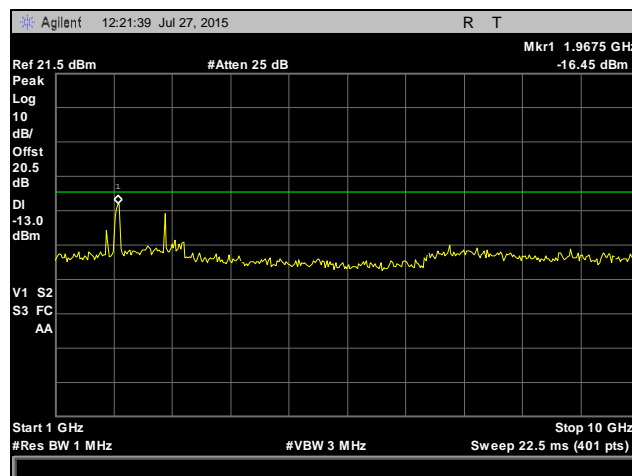

Plot 114. Conducted Spurious Emissions, GSM, High Channel, 1 GHz – 10 GHz, Part 22

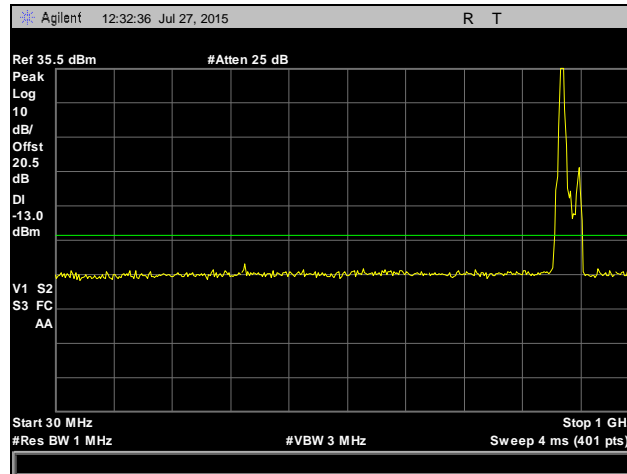

Plot 115. Conducted Spurious Emissions, WCDMA, Low Channel, 30 MHz – 1 GHz, Part 22

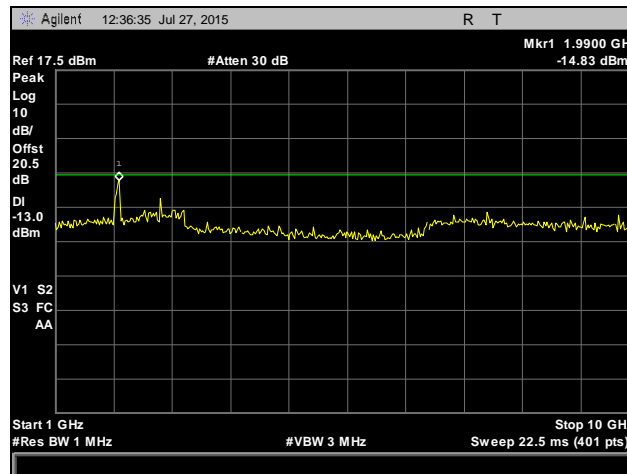

Plot 116. Conducted Spurious Emissions, WCDMA, Low Channel, 1 GHz – 10 GHz, Part 22

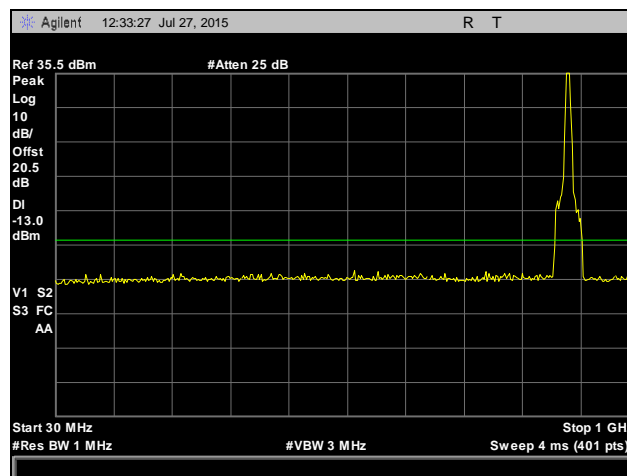

Plot 117. Conducted Spurious Emissions, WCDMA, Mid Channel, 30 MHz – 1 GHz, Part 22

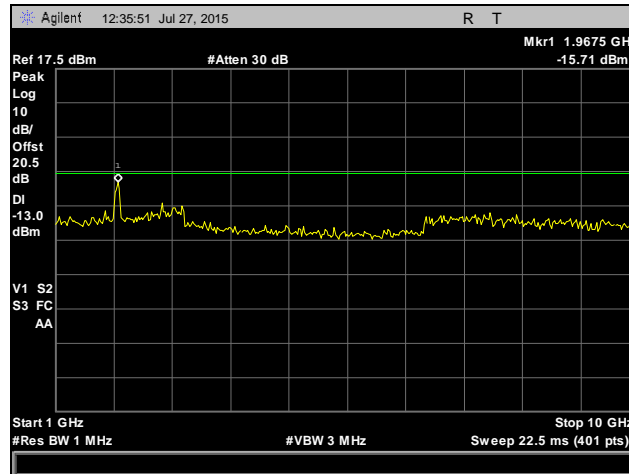

Plot 118. Conducted Spurious Emissions, WCDMA, Mid Channel, 1 GHz – 10 GHz, Part 22

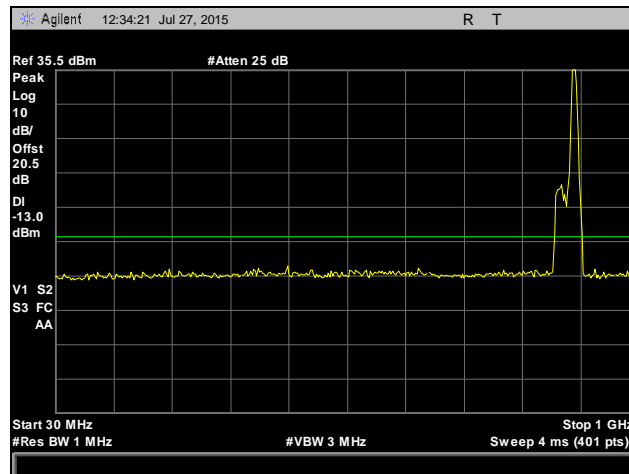

Plot 119. Conducted Spurious Emissions, WCDMA, High Channel, 30 MHz – 1 GHz, Part 22

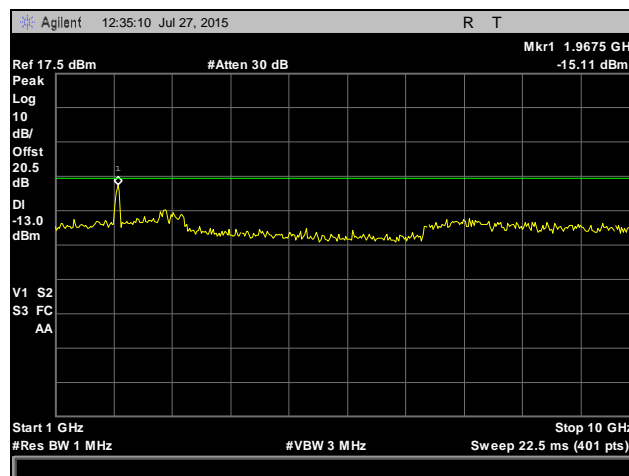

Plot 120. Conducted Spurious Emissions, WCDMA, High Channel, 1 GHz – 10 GHz, Part 22

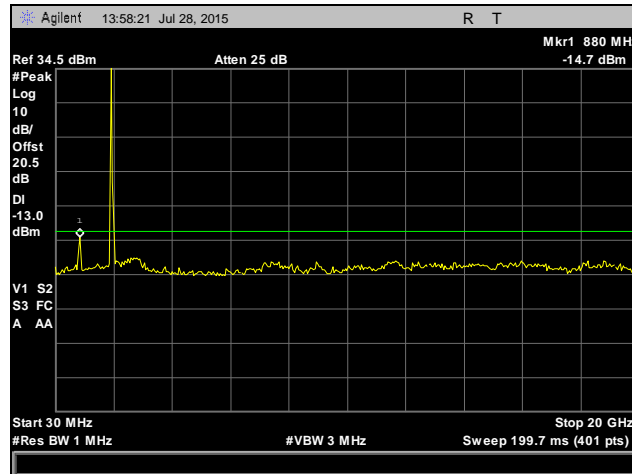

Plot 121. Conducted Spurious Emissions, CDMA, Low Channel, 30 MHz – 20 GHz, Part 24

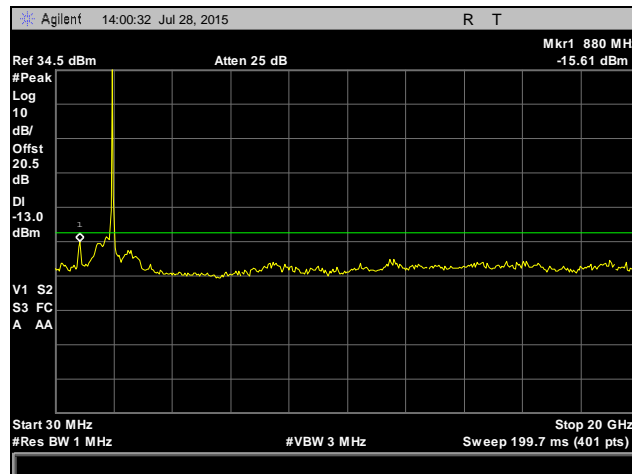

Plot 122. Conducted Spurious Emissions, CDMA, Mid Channel, 30 MHz – 20 GHz, Part 24

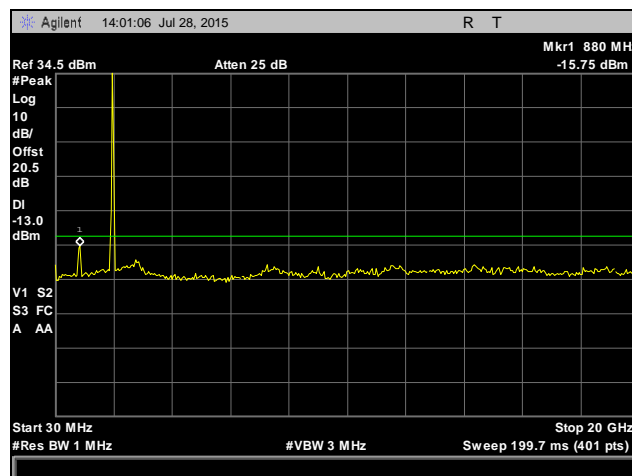

Plot 123. Conducted Spurious Emissions, CDMA, High Channel, 30 MHz – 20 GHz, Part 24

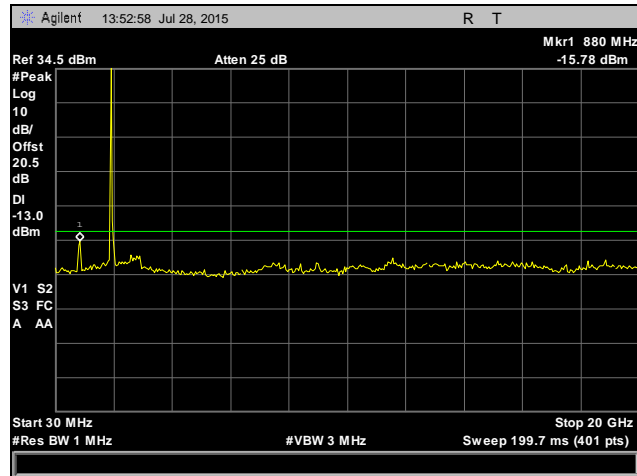

Plot 124. Conducted Spurious Emissions, GSM, Low Channel, 30 MHz – 20 GHz, Part 24

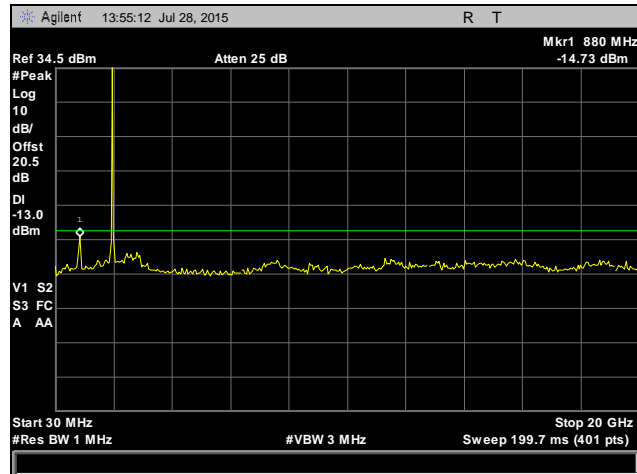

Plot 125. Conducted Spurious Emissions, GSM, Mid Channel, 30 MHz – 20 GHz, Part 24

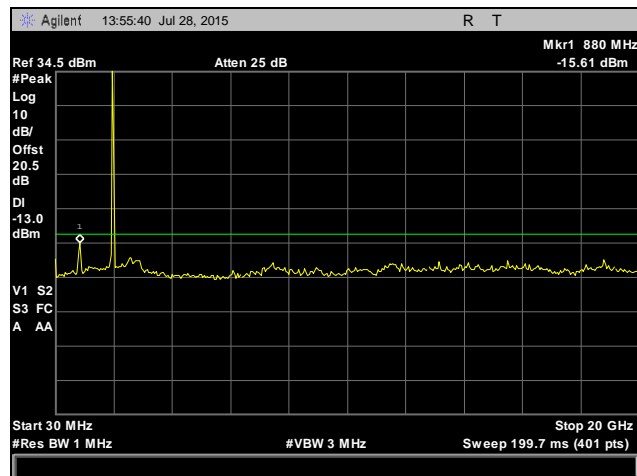

Plot 126. Conducted Spurious Emissions, GSM, High Channel, 30 MHz – 20 GHz, Part 24

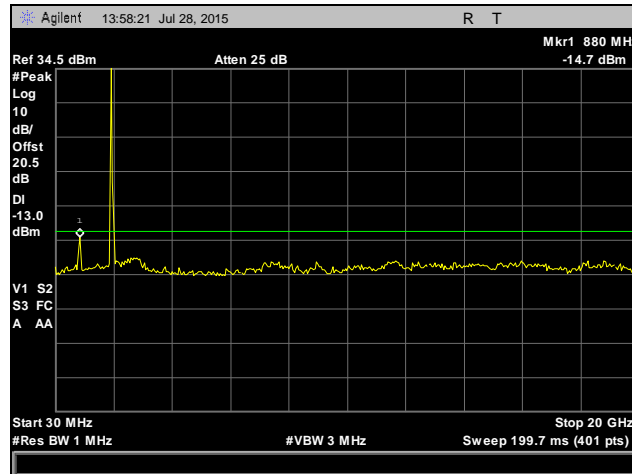

Plot 127. Conducted Spurious Emissions, WCDMA, Low Channel, 30 MHz – 20 GHz, Part 24

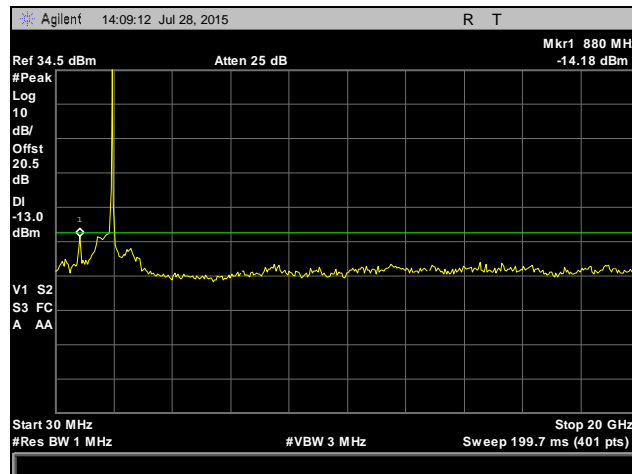

Plot 128. Conducted Spurious Emissions, WCDMA, Mid Channel, 30 MHz – 20 GHz, Part 24

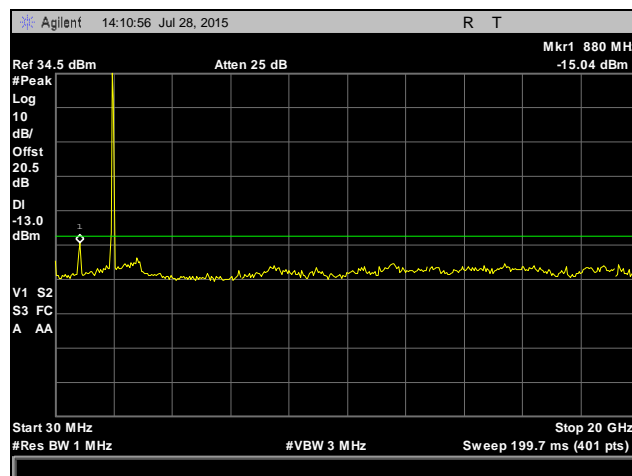

Plot 129. Conducted Spurious Emissions, WCDMA, High Channel, 30 MHz – 20 GHz, Part 24

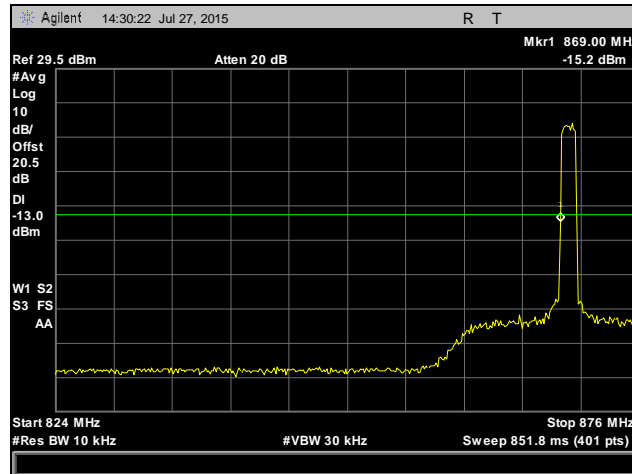

Plot 130. Conducted Band Edge, CDMA, Low Channel, Part 22

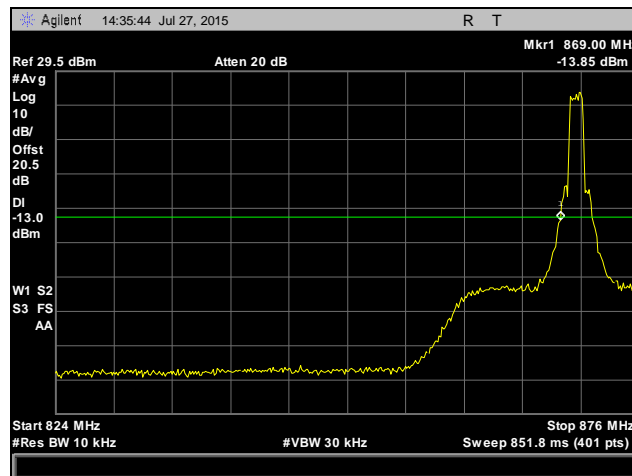

Plot 131. Conducted Band Edge, CDMA, Low Channel, Channel 14, Part 22

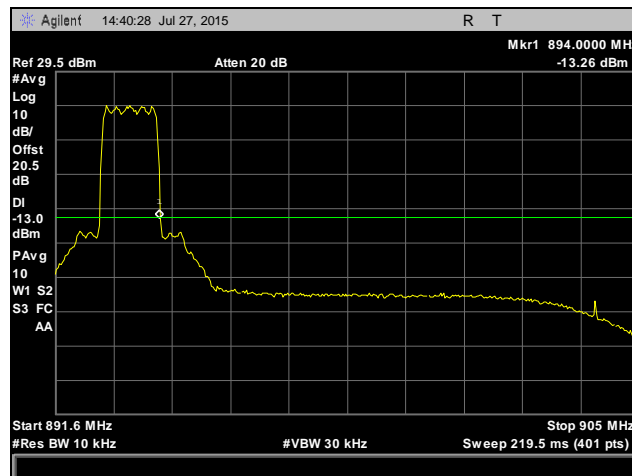

Plot 132. Conducted Band Edge, CDMA, High Channel, Part 22

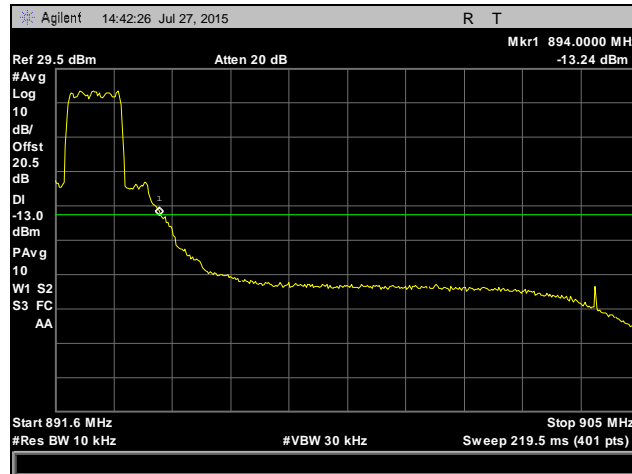

Plot 133. Conducted Band Edge, CDMA, High Channel, Channel 750, Part 22

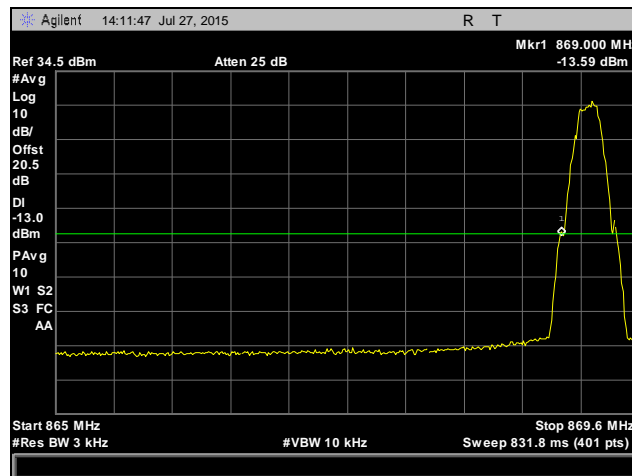

Plot 134. Conducted Band Edge, GSM, Low Channel, Part 22

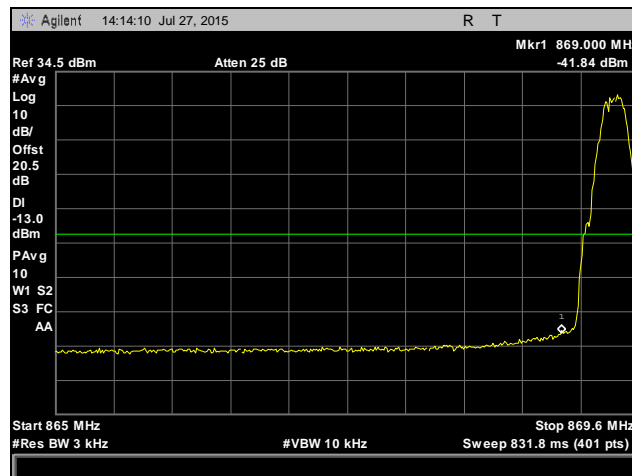

Plot 135. Conducted Band Edge, GSM, Low Channel, Channel 129, Part 22

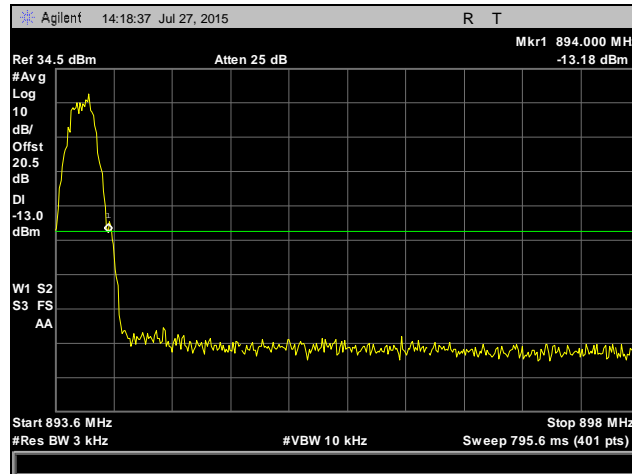

Plot 136. Conducted Band Edge, GSM, High Channel, Part 22

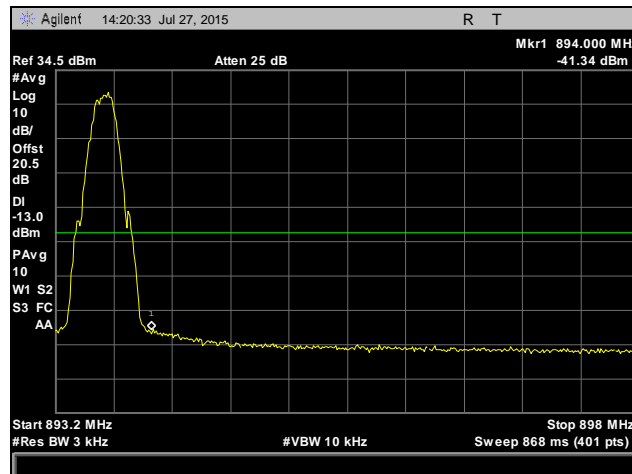

Plot 137. Conducted Band Edge, GSM, High Channel, Channel 250, Part 22

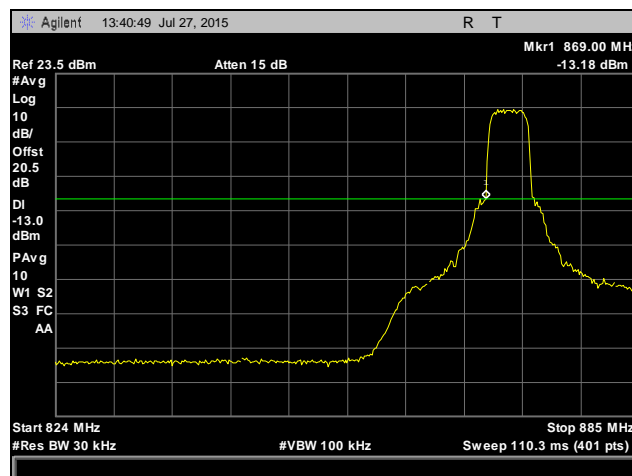

Plot 138. Conducted Band Edge, WCDMA, Low Channel, Part 22

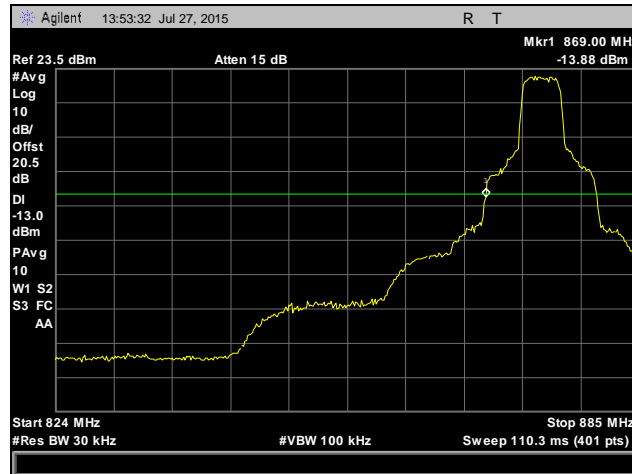

Plot 139. Conducted Band Edge, WCDMA, Low Channel, Channel 4374, Part 22

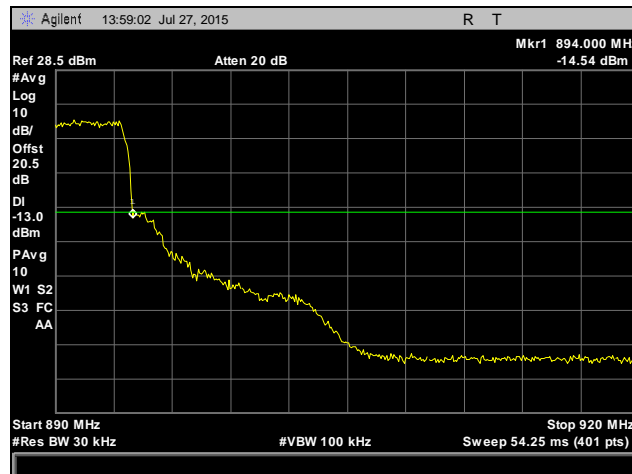

Plot 140. Conducted Band Edge, WCDMA, High Channel, Part 22

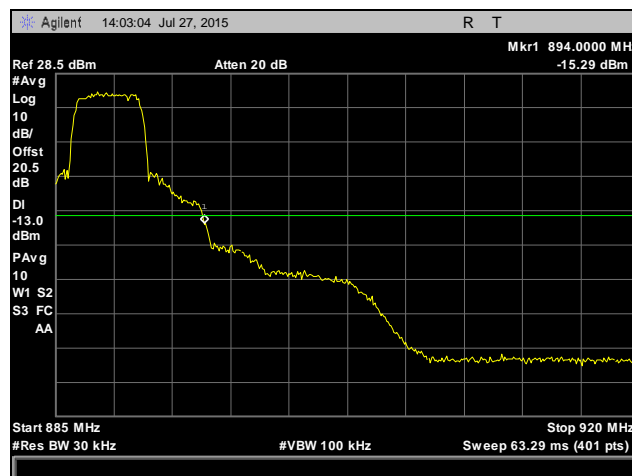

Plot 141. Conducted Band Edge, WCDMA, High Channel, Channel 4441, Part 22

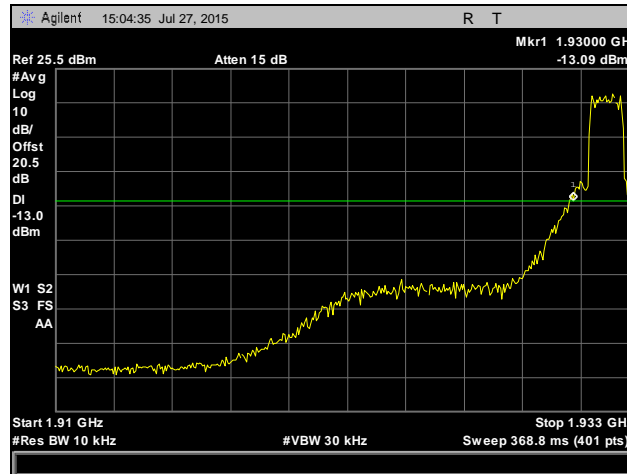

Plot 142. Conducted Band Edge, CDMA, Low Channel, Part 24

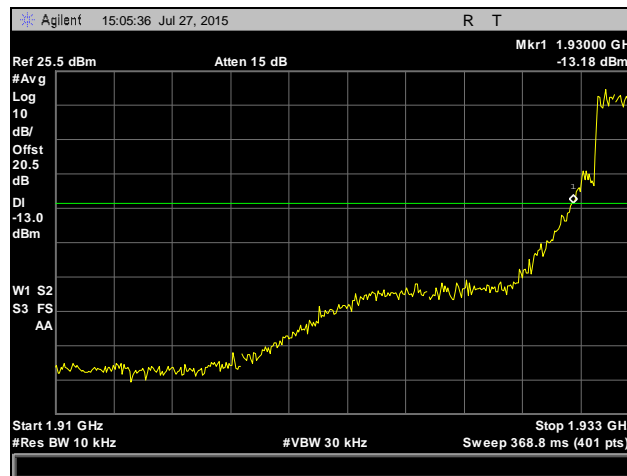

Plot 143. Conducted Band Edge, CDMA, Low Channel, Channel 30, Part 24

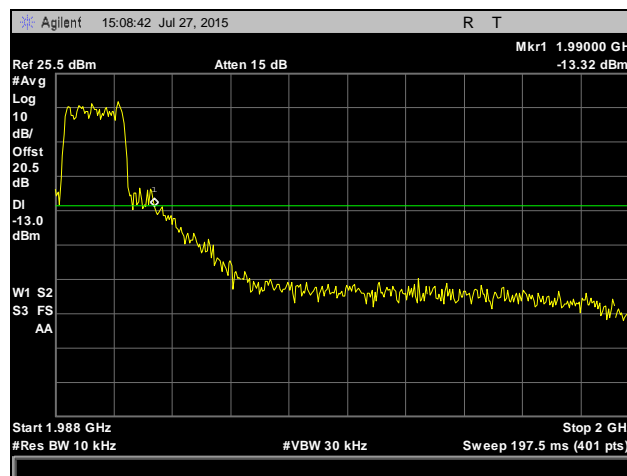

Plot 144. Conducted Band Edge, CDMA, High Channel, Part 24

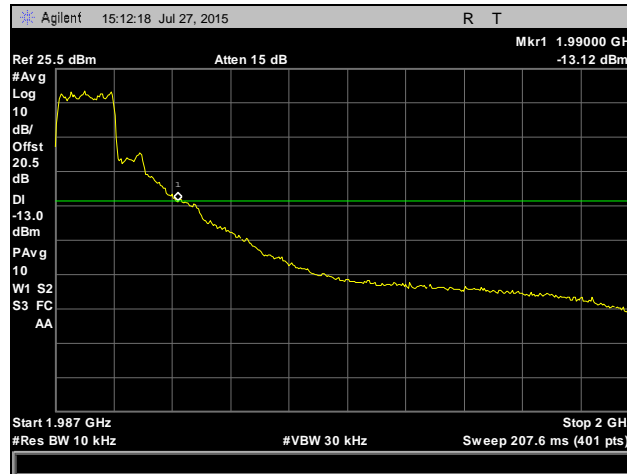

Plot 145. Conducted Band Edge, CDMA, High Channel, Channel 1160, Part 24

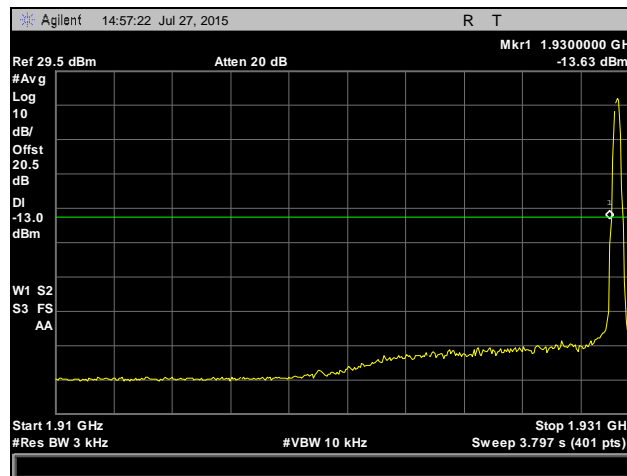

Plot 146. Conducted Band Edge, GSM, Low Channel, Part 24

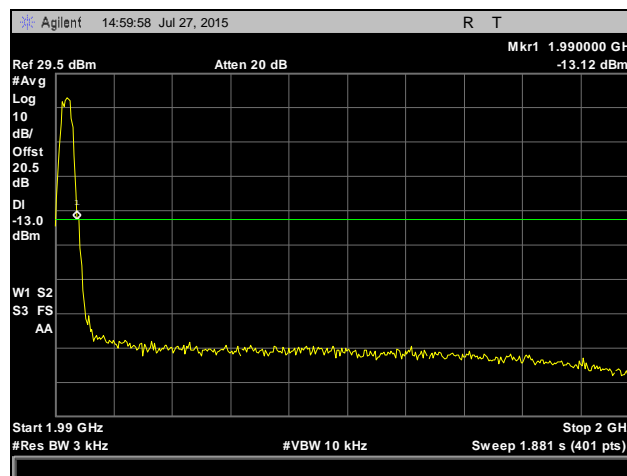

Plot 147. Conducted Band Edge, GSM, High Channel, Part 24

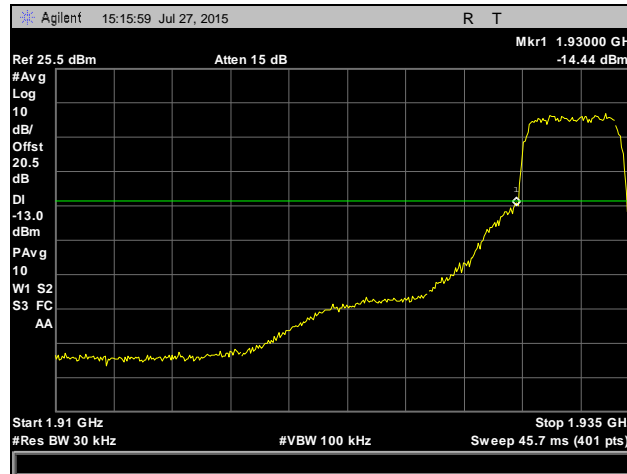

Plot 148. Conducted Band Edge, WCDMA, Low Channel, Part 24

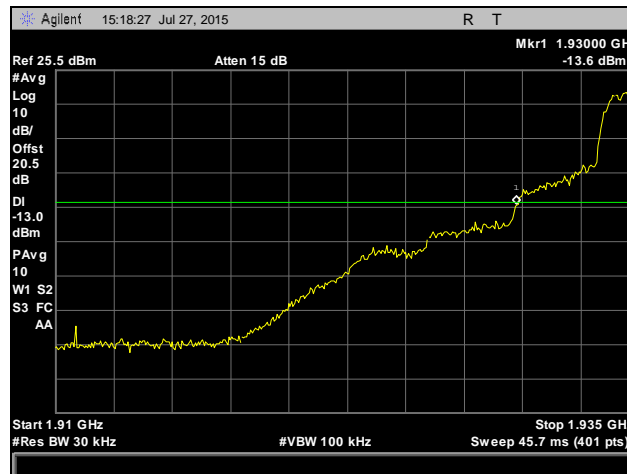

Plot 149. Conducted Band Edge, WCDMA, Low Channel, Channel 9679, Part 24

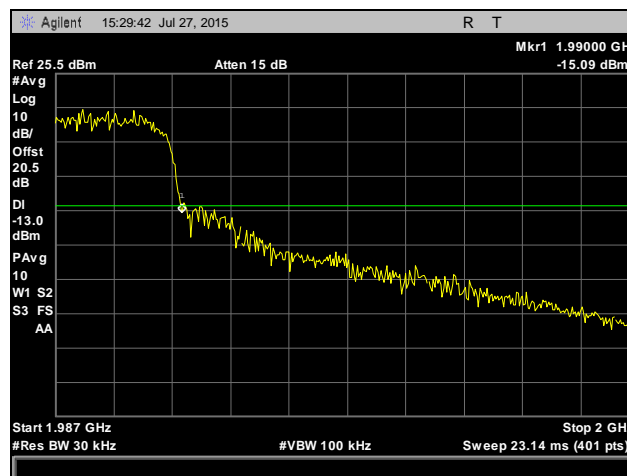

Plot 150. Conducted Band Edge, WCDMA, High Channel, Part 24



Plot 151. Conducted Band Edge, WCDMA, High Channel, Channel 9900, Part 24



Electromagnetic Compatibility Criteria for Intentional Radiators

Out of Band Rejection

Test Requirement(s): Test for rejection of out-of-band signals

Test Procedures: A signal generator was used to drive the input of the EUT. The signal generator was swept across the band of interest. Filter frequency response plots were taken.

Test Results: The EUT complies with the requirements of this section.

Test Engineer: Benjamin Taylor

Test Results: 07/28/15

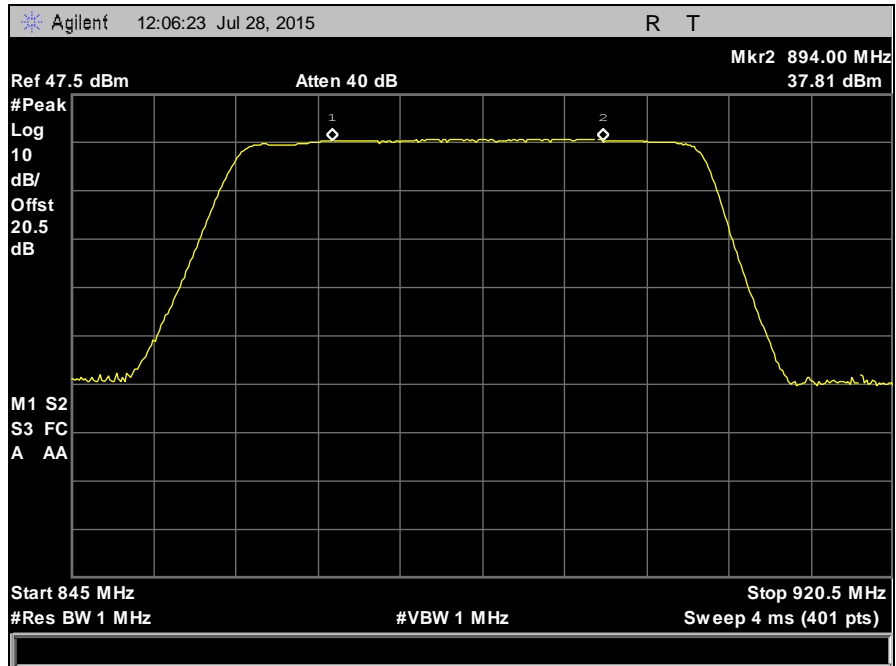

Plot 152. Filter Response, Part 22

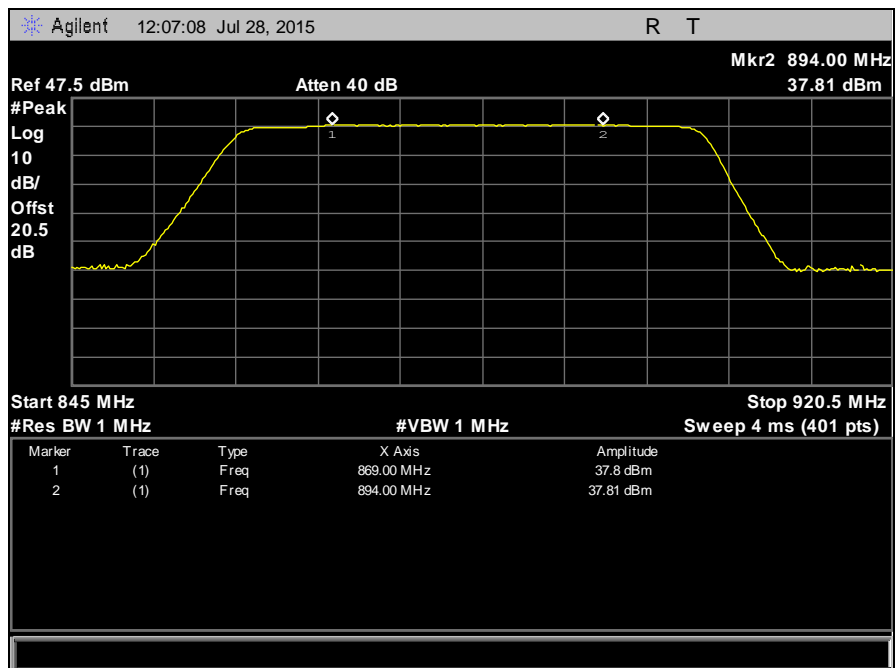

Plot 153. Filter Response with Marker Table, Part 22

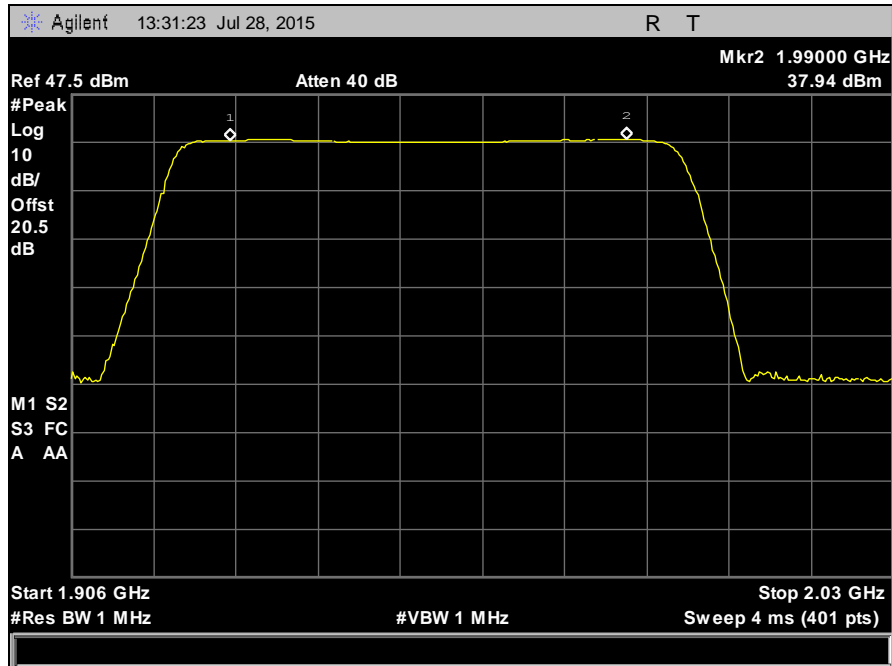

Plot 154. Filter Response, Part 24

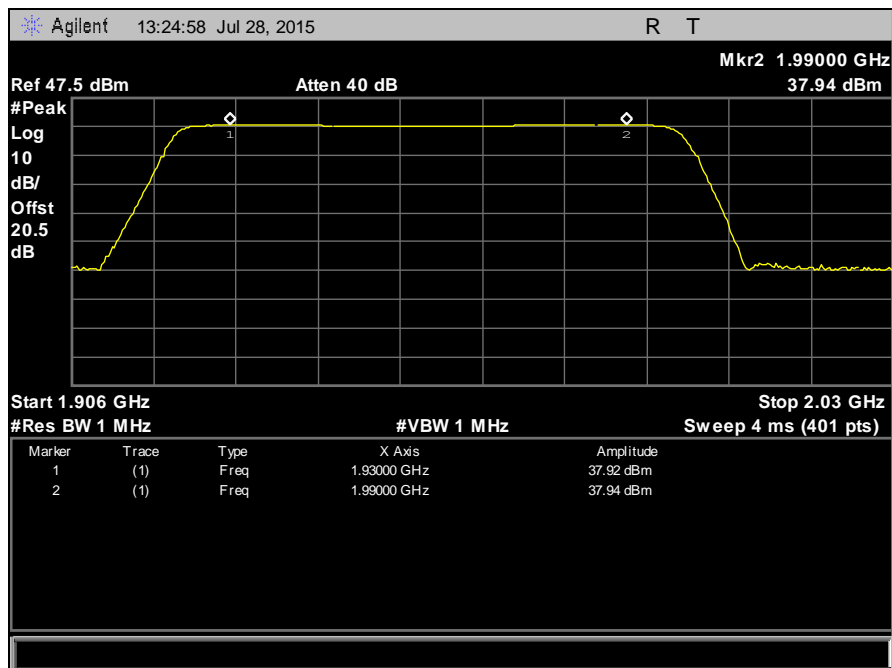

Plot 155. Filter Response with Marker Table, Part 24



Electromagnetic Compatibility Criteria for Intentional Radiators

Intermodulation

- Test Requirement(s):** Intermodulation – Test all modulation types [TDMA, CDMA, and FM (covers GSM and F1D)]
- CW signal rather than typical signal is acceptable (for FM).
 - At maximum drive level, for each modulation: one test with three tones, or two tests (High-, low-band edge) with two tones)
 - Limit usually is -13 dBm conducted.
 - Not needed for Single Channel systems
 - Combination of modulation types not needed.
- Test Procedures:** The two tone test method was used. A signal generator was used to drive the input of the EUT. The EUT was evaluated at the high and low band edge.
- Test Results:** The EUT complies with the requirements of this section. Inter modulation will only pass for low power setting. Therefore, high power setting cannot be used when there are multiple channels per band.
- Test Engineer(s):** Benjamin Taylor
- Test Date(s):** 07/28/15

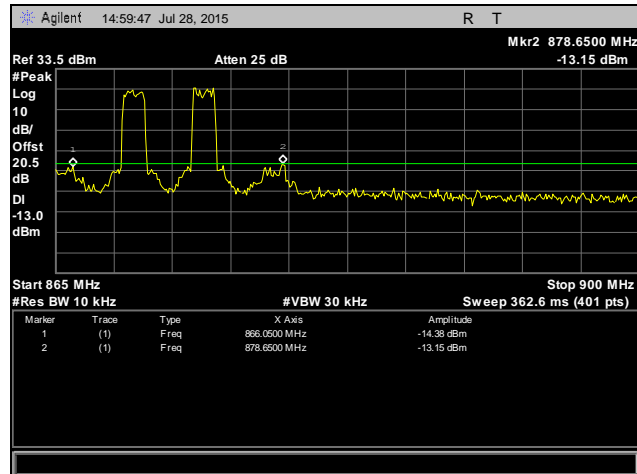

Plot 156. Intermodulation, CDMA, Low Channel, Part 22

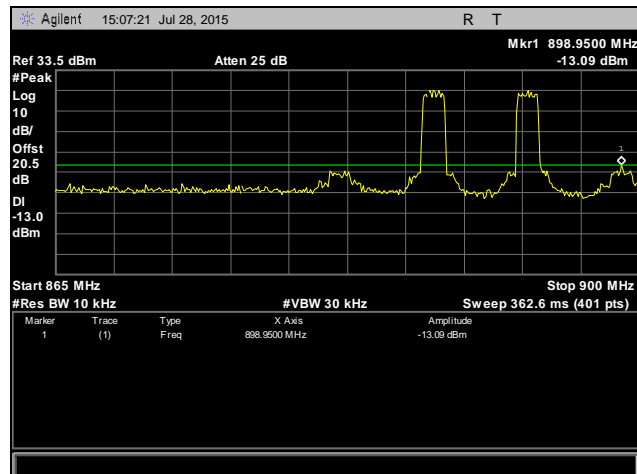

Plot 157. Intermodulation, CDMA, High Channel, Part 22

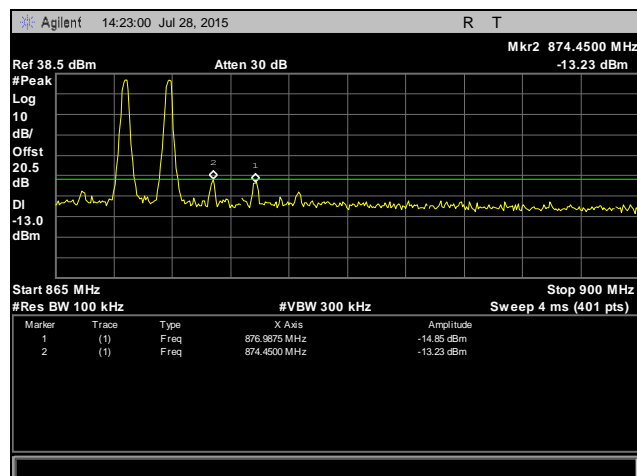

Plot 158. Intermodulation, GSM, Low Channel, Part 22

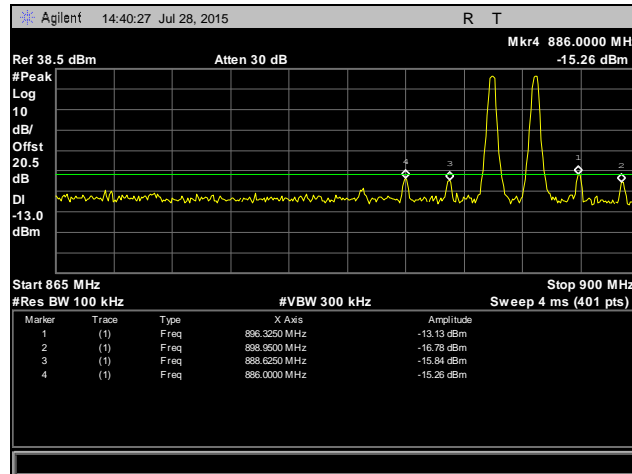

Plot 159. Intermodulation, GSM, High Channel, Part 22

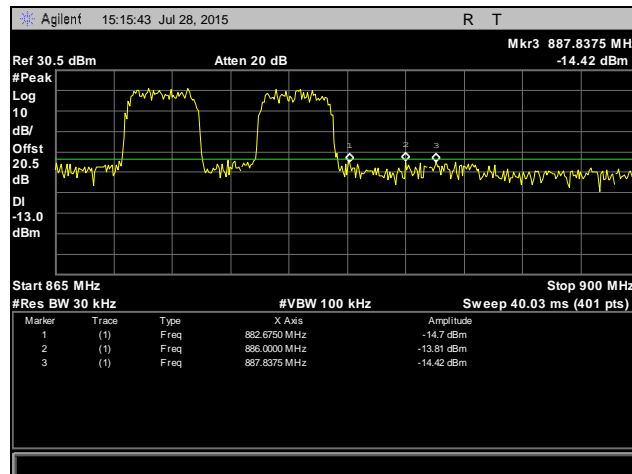

Plot 160. Intermodulation, WCDMA, Low Channel, Part 22

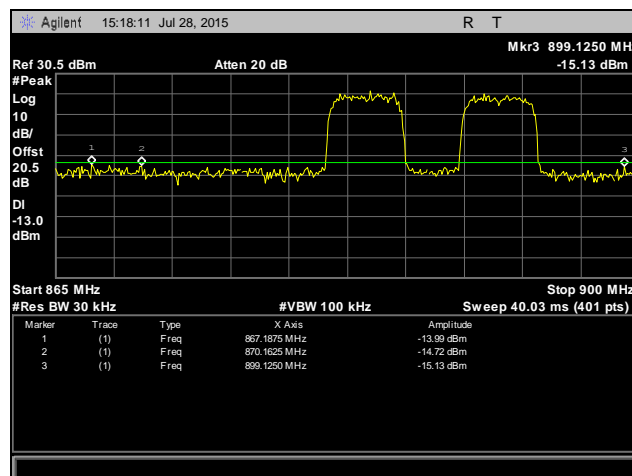

Plot 161. Intermodulation, WCDMA, High Channel, Part 22

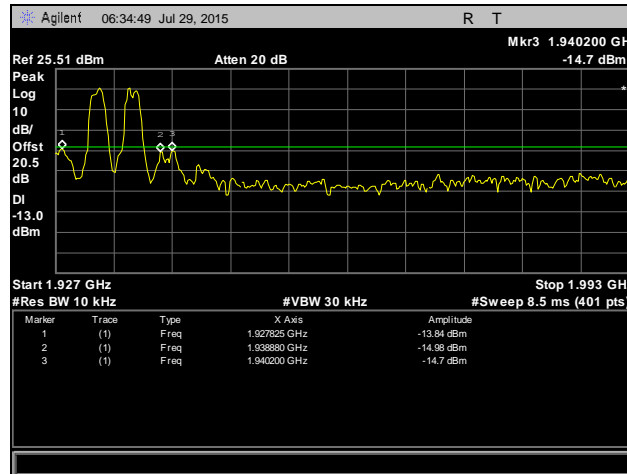

Plot 162. Intermodulation, CDMA, Low Channel, Part 24

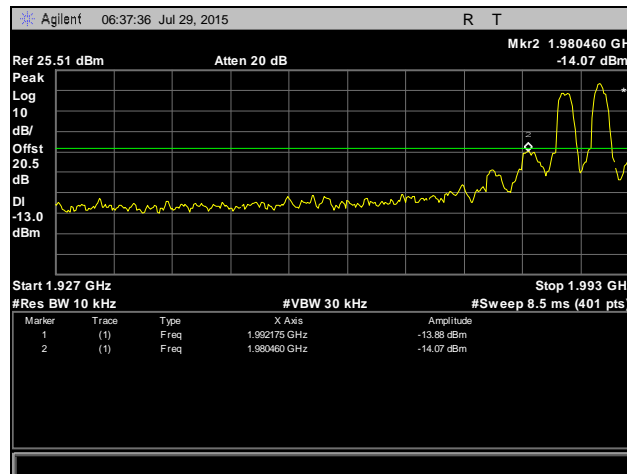

Plot 163. Intermodulation, CDMA, High Channel, Part 24

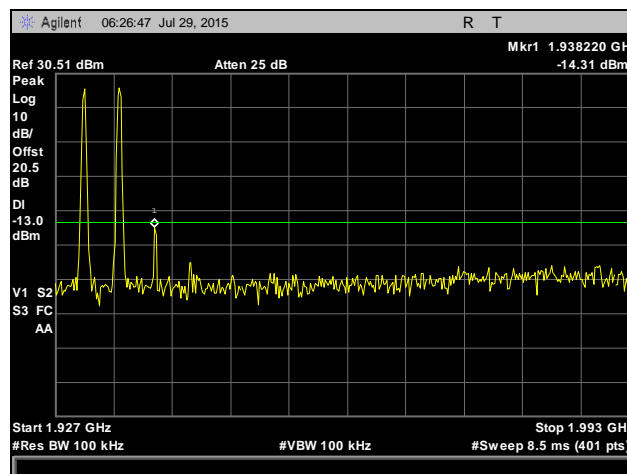

Plot 164. Intermodulation, GSM, Low Channel, Part 24

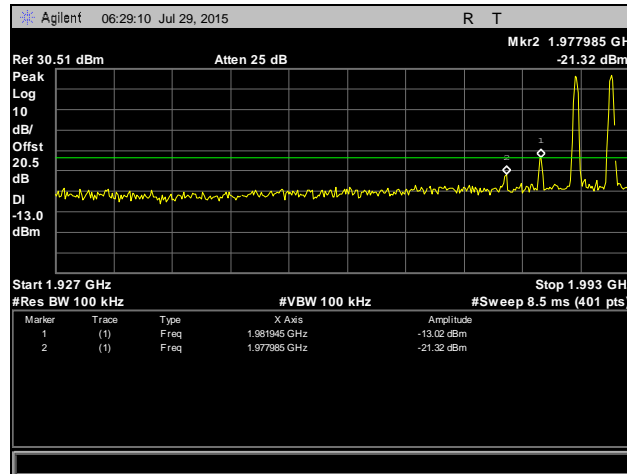

Plot 165. Intermodulation, GSM, High Channel, Part 24

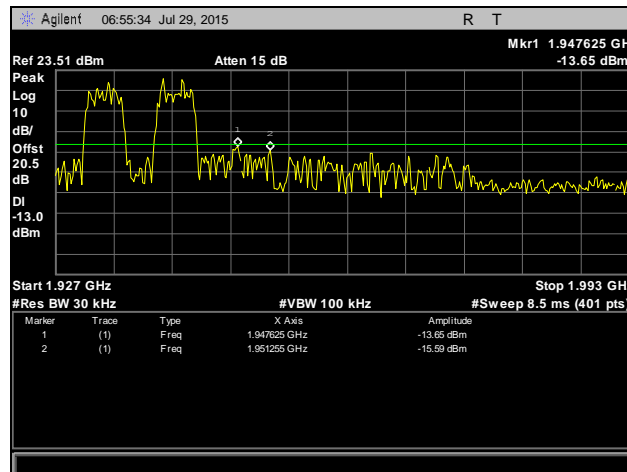

Plot 166. Intermodulation, WCDMA, Low Channel, Part 24

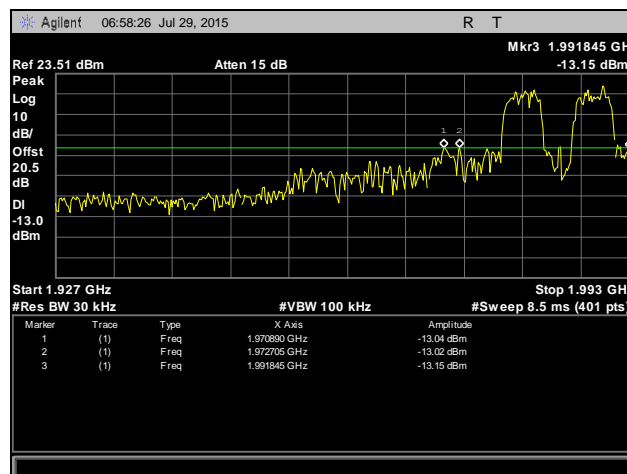

Plot 167. Intermodulation, WCDMA, High Channel, Part 24



IV. Test Equipment



Test Equipment

Calibrated test equipment utilized during testing was maintained in a current state of calibration per the requirements of ISO/IEC 17025:2005.

MET Asset #	Equipment	Manufacturer	Model	Last Cal Date	Cal Due Date
1T6658	SPECTRUM ANALYZER	AGILENT	E4407B	11/05/2014	11/05/2015
1T4497	SIGNAL GENERATOR	AGILENT TECHNOLOGIES	E4432B	10/06/2014	04/06/2016
1T4483	ANTENNA; HORN	ETS-LINDGREN	3117	02/28/2014	08/28/2015
1T4771	PSA SPECTRUM ANALYZER	AGILENT TECHNOLOGIES	E4446A	11/25/2014	05/25/2016
1T4300B	SEMI-ANECHOIC 3M CHAMBER # 1 D (2043A-1) (IC)	EMC TEST SYSTEMS	NONE	01/11/2015	01/11/2018
1T4409	EMI RECEIVER	ROHDE & SCHWARZ	ESIB7	10/29/2014	10/29/2016
1T4751	ANTENNA - BILOG	SUNOL SCIENCES	JB6	07/29/2014	01/29/2016
1T4149	HIGH-FREQUENCY ANECHOIC CHAMBER	RAY-PROOF	81	NOT REQUIRED	
1T4442	PRE-AMPLIFIER, MICROWAVE	MITEQ	AFS42-01001800-30-10P	SEE NOTE	
1T4859	DIGITAL BAROMETER, HYGROMETER, THERMOMETER	CONTROL COMPANY	15-078-198, FB70423, 245CD	12/19/2013	12/19/2015

Note: Functionally tested equipment is verified using calibrated instrumentation at the time of testing.



End of Report