



A Test Lab Techno Corp.

No.140-1, Chang-an St., Bade City, Tao-Yuan County 334, Taiwan (R.O.C.)
Tel : +886-3-2710188 / Fax : +886-3-2710190

Part 15 C Measurement Report



Report No.	: 0909FR11
Applicant	: BaudTec Corporation
Product Name	: Wireless 802.11b/g ADSL2+ Router
Trade Name	: BaudTec
Model No.	: TW263R4
FCC ID	: XKR-TW263R4
Dates of Test	: Sep. 04 ~ Sep. 07, 2009
Test Specification	: FCC CFR Title 47 Part 15 Subpart C (15.247) (2008-10) PUBLIC NOTICE :DA 00-705 Filing and Measurement Guidelines for Frequency Hopping Spread Spectrum Systems
Location of Test Lab.	: Chang-an Lab.

1. The test operations have to be performed with cautious behavior, the test results are as attached.
2. The test results are under chamber environment of A Test Lab Techno Corp. A Test Lab Techno Corp. does not assume responsibility for any conclusions and generalizations drawn from the test results with regard to other specimens or samples.
3. The measurement report has to be written approval of A Test Lab Techno Corp. It may only be reproduced or published in full. This report shall not be reproduced except in full, without the written approval of A Test Lab Techno Corp.
4. This document may be altered or revised by A Test Lab Techno. Corp. personnel only, and shall be noted in the revision section of the document.



Miller Lee 20090914
Approve Signer

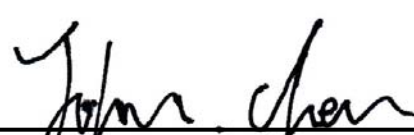

John Cheng 20090914
Testing Engineer



CERTIFICATION

We hereby verify that:

The test data, data evaluation, test procedures and equipment configurations shown in this report were made in accordance with the procedures given in ANSI C63.4:2003. All test were conducted by *A Test Lab Techno Corp. No.140-1, Chang-an St., Bade City, Tao-Yuan County 334, Taiwan (R.O.C.)* Also, we attest to the accuracy of each.

We further submit that the energy emitted by the sample EUT tested as described in the report is in compliance with Class B radiated and conducted emission limit of FCC Rules Part 15 Subpart C (15.247).

Product Name : Wireless 802.11b/g ADSL2+ Router
Applicant : BaudTec Corporation
Applicant Address : 12F, No.181, Sec. 1, Tatung Rd., Hsichih City, Taipei Hsien 221, Taiwan, R.O.C.
Manufacturer : BaudTec Corporation
Manufacturer Address : 12F, No.181, Sec. 1, Tatung Rd., Hsichih City, Taipei Hsien 221, Taiwan, R.O.C.
Trade Name : BaudTec
Model No. : TW263R4
FCC ID : XKR-TW263R4
Rated Voltage : 100-240Vac, 0.5A, 50/60Hz
EUT Voltage : 12Vdc, 1A
Applicable Standard : FCC CFR Title 47 Part 15 Subpart C (15.247) (2008-10)
Classification : B
Test Result : Complied

Approved by : 
Miller Lee 2009/09/14

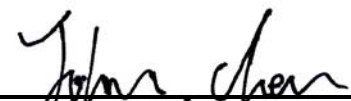
Prepared by : 
John Cheng 2009/09/14

A Test Lab Techno Corp.

No.140-1, Chang-an St., Bade City, Tao-Yuan County 334, Taiwan (R.O.C.)
Tel : 03-2710188 / Fax : 03-2710190



Contents

1. GENERAL.....	4
2. Conducted Emissions Requirements	6
3. Radiated Emissions Requirements.....	10
4. Maximum Conducted Output Power Requirements	34
5. Minimum 6dB RF Bandwidth Requirements	37
6. Maximum Power Density Requirements.....	43
7. Out of Band Conducted Emissions Requirements.....	49
8. Band Edges Requirements	58
9. Antenna Requirements.....	69



1. GENERAL

1.1 Description of Equipment under Test (EUT)

Applicant	: BaudTec Corporation
Applicant Address	: 12F, NO, 181, Sec.1.TatungRd., His-chih City, Taipei county, Taiwan 221
Manufacturer	: BaudTec Corporation
Manufacturer Address	: 12F, NO, 181, Sec.1.TatungRd., His-chih City, Taipei county, Taiwan 221
Product Name	: Wireless 802.11b/g ADSL2+ Router
Trade Name	: BaudTec
Model No.	: TW263R4
Frequency Range	: IEEE 802.11b / IEEE 802.11g: 2412MHz~2462MHz
Type of Modulation	: IEEE 802.11b:DSSS(CCK, DQPSK, DBPSK) IEEE 802.11g:DSSS(CCK, DQPSK, DBPSK)+ OFDM(QPSK, BPSK, 16-QAM, 64-QAM)
Hardware Version	: 7000-06I7-00
Software Version	: STD(P2F_85)_A07(211650_310250)
Component	
Power Adapter (1)	: ADS10-W 120100 Input:100-240Vac, 0.5A, 50/60Hz Output: 12Vdc, 1A Cable out: Non-Shielded, 1.5 m

1.2 Introduction

The following measurement report is submitted on behalf of **BaudTec Corporation** In support of a Class B Digital Device certification in accordance with Part2 Subpart J and Part 15 Subpart A and B&C of the Commission's and Regulations.

1.3 Summary of Tests

47 CFR Part 15 Subpart C			
Reference	Test	Results	Note
15.207	AC Power Conducted Emission	PASS	-----
15.247(c)	Transmitter Radiated Emissions	PASS	-----
15.247(b)	Max. Output Power	PASS	-----
15.247(a)(2)	6dB RF Bandwidth	PASS	-----
15.247(d)	Max. Power Density	PASS	-----
15.247(c)	Out of Band Conducted Spurious Emission	PASS	-----
15.247(c)	Band Edge Measurement	PASS	-----
15.203	Antenna Requirement	PASS	-----

1.4 Configuration of System under Test

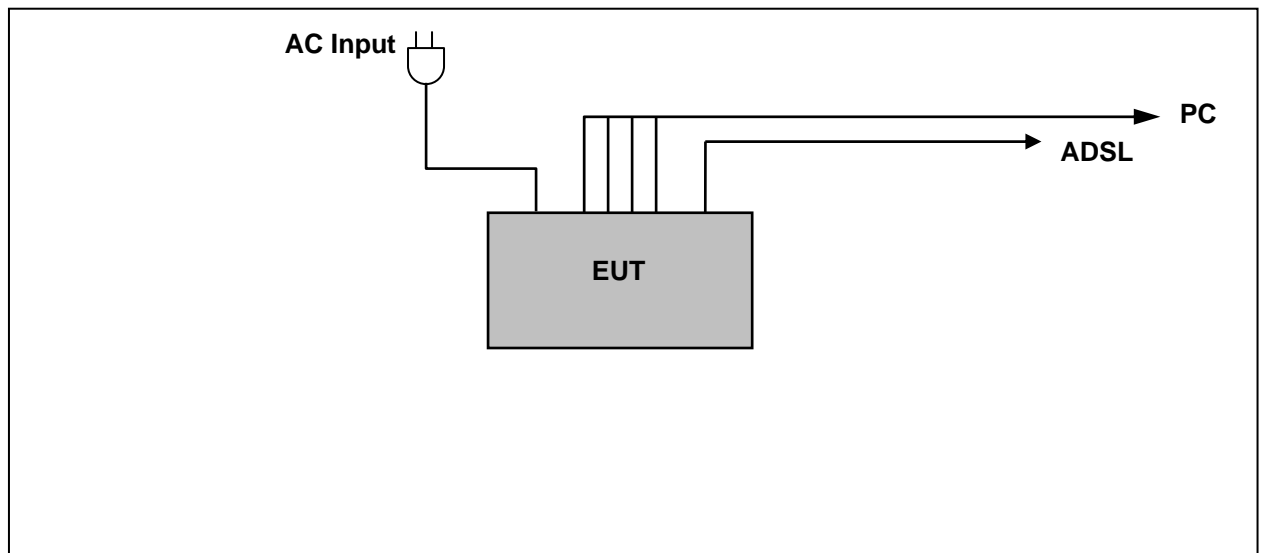

During testing the EUT's LAN port connected to the PC and ADSL port connect ADSL.



2. Conducted Emissions Requirements

2.1 Test Procedure

The EUT and simulators are connected to the main power through a line impedance stabilization network (L.I.S.N.). This provides a 50ohm//50uH coupling impedance for the measuring equipment. The peripheral devices are also connected to the main power through a LISN that provides a 50ohm /50uH coupling impedance with 50ohm termination. (Please refer to the block diagram of the test setup and photographs.)

Both sides of A.C. line are checked for maximum conducted interference. In order to find the maximum emission, the relative positions of equipment and all of the interface cables must be changed according to ANSI C63.4: 2003 on conducted measurement.

Conducted emissions were investigated over the frequency range from 0.15MHz to 30MHz using a receiver bandwidth of 9 kHz.

2.2 Limits

Frequency range (MHz)	Limits (dBuV)	
	Quasi-peak	Average
0.15 to 0.50	66 to 56	56 to 46
0.50 to 5.0	56	46
5.0 to 30	60	50

2.3 Test Equipment List

Describe	Manufacturer	Model	Serial Number	Calibration	
				Cal. Date	Due Date
Spectrum Analyzer	Advantest	R3132	160300103	Mar. 10, 2009	Mar. 10, 2010
Test Receiver	R&S	ESCI	100367	Jun. 05, 2009	Jun. 05, 2010
LISN	EMCO	3816/2 SH	00060110	Jun. 05, 2009	Jun. 05, 2010
LISN	EMCO	3816/2 SH	00060111	Jun. 29, 2009	Jun. 29, 2010
Transient Limiter	ELECTRO-METRICS	EM-7600	777	Sep. 22, 2008	Sep. 22, 2009

2.4 Test Instruments Configuration

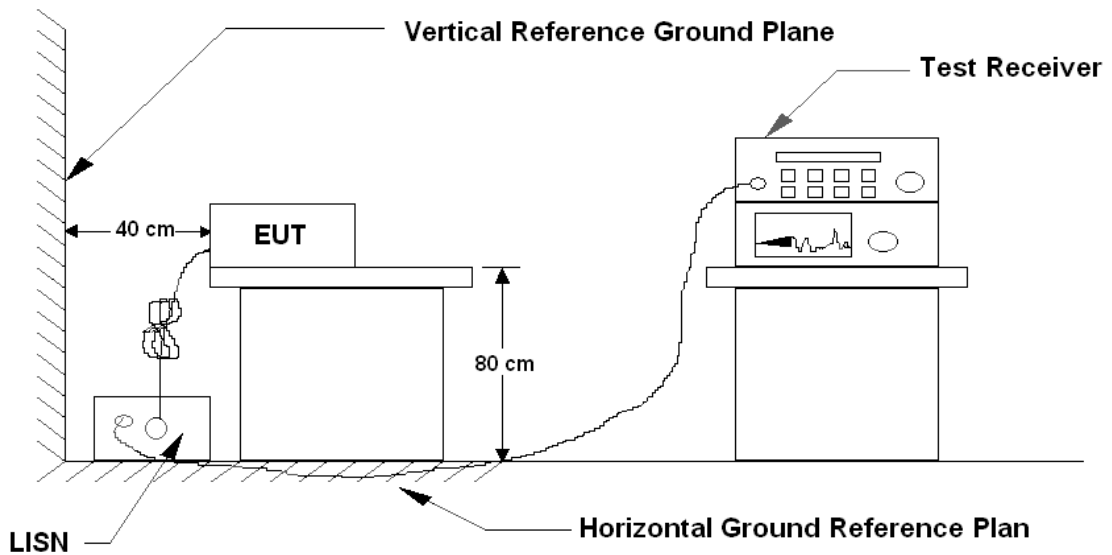

2.5 Test Results

EUT : Wireless 802.11b/g ADSL2+ Router
Model No. : TW263R4
Test Mode : Link Mode
Test Date : 08/28/2009

Please refer to next page of detail testing data.

Notes:

1. L1: One end & Ground L2: The other end & Ground
2. Height of table on which the EUT was placed: 0.8 m.
3. The Quasi-Peak Value have already met the Average Value Limit showed on above limits.
4. The above test results are obtained under the normal condition.



File :FCC
80.0 dBuV

Data :#1

Date: 2009/8/28

Time: 上午 12:45:19

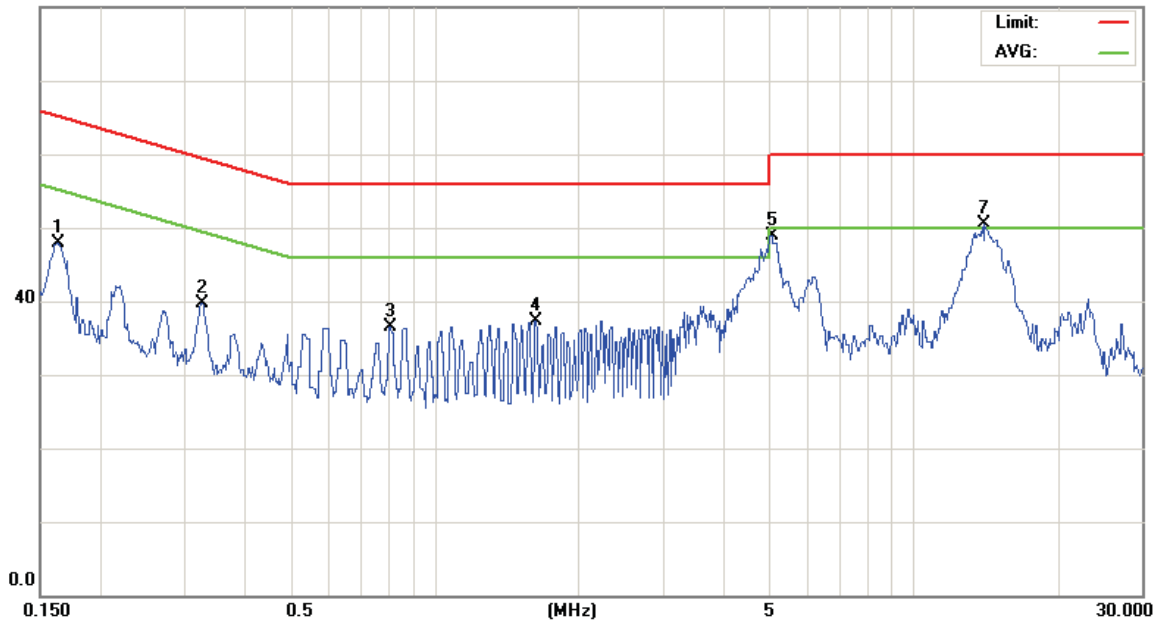

Site site#1 Phase: **L1** Temperature: 26 °C
 Limit: CISPR22 Class B Conduction(QP) Power: AC 120V/60Hz Humidity: 55 %
 EUT:
 M/N: 09-0216-EP
 Mode: Link Mode
 Note:

No.	Mk.	Freq. MHz	Reading Level dBuV	Correct Factor dB	Measure- ment dBuV	Limit dBuV	Over dB	Detector	Comment
1		0.1626	38.16	9.73	47.89	65.32	-17.43	peak	
2		0.3257	30.02	9.77	39.79	59.56	-19.77	peak	
3		0.8059	26.61	9.80	36.41	56.00	-19.59	peak	
4		1.6250	27.43	9.83	37.26	56.00	-18.74	peak	
5		5.0500	38.77	10.08	48.85	60.00	-11.15	peak	
6		5.0500	20.32	10.08	30.40	50.00	-19.60	AVG	
7	*	14.0500	40.40	10.20	50.60	60.00	-9.40	peak	
8		14.0500	23.70	10.20	33.90	50.00	-16.10	AVG	

*:Maximum data x:Over limit !:over margin

●Reference Only



File :FCC
80.0 dBuV

Data :#2

Date: 2009/8/28

Time: 上午 12:51:43

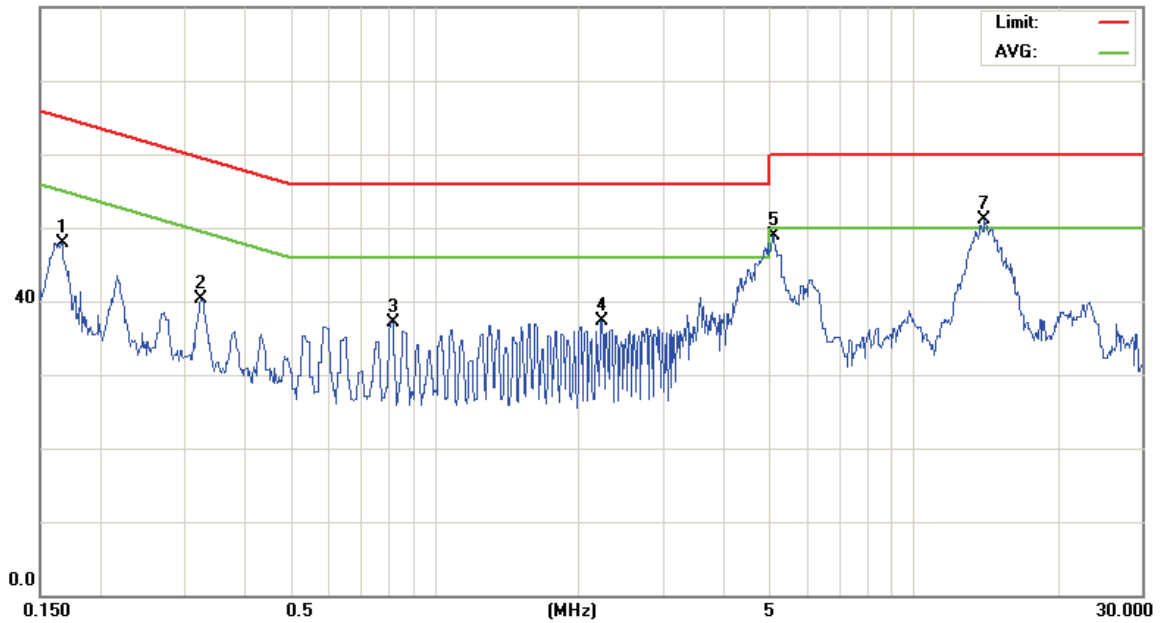

Site site#1 Phase: **L2** Temperature: 26 °C
 Limit: CISPR22 Class B Conduction(QP) Power: AC 120V/60Hz Humidity: 55 %
 EUT:
 M/N: 09-0216-EP
 Mode: Link Mode
 Note:

No.	Mk.	Freq. MHz	Reading Level dBuV	Correct Factor dB	Measure- ment dBuV	Limit dBuV	Over dB	Detector	Comment
1		0.1661	38.18	9.73	47.91	65.15	-17.24	peak	
2		0.3243	30.46	9.77	40.23	59.59	-19.36	peak	
3		0.8150	27.27	9.80	37.07	56.00	-18.93	peak	
4		2.2280	27.35	9.88	37.23	56.00	-18.77	peak	
5		5.1000	38.78	10.08	48.86	60.00	-11.14	peak	
6		5.1000	24.72	10.08	34.80	50.00	-15.20	AVG	
7	*	14.0500	40.91	10.20	51.11	60.00	-8.89	peak	
8		14.0500	24.70	10.20	34.90	50.00	-15.10	AVG	

*:Maximum data x:Over limit !:over margin

●Reference Only



3. Radiated Emissions Requirements

3.1 Test Procedure

The EUT and its simulators are placed on a turn table which is 0.8 meter above ground. The turn table can rotate 360 degrees to determine the position of the maximum emission level.

The antenna can move up and down between 1 meter and 4 meters to find out the maximum emission level.

Both horizontal and vertical polarization of the antenna are set on measurement. In order to find the maximum emission, all of the interface cables must be manipulated according to ANSI C63.4:2003 on radiated measurement.

The EUT was positioned such that the distance from antenna to the EUT was 10 meters for the frequency under 1GHz and 3 meters for the frequency above 1GHz.

The bandwidth below 1GHz setting on the field strength meter (R&S Test Receiver ESCS 30) is 120 kHz and above 1GHz is 1MHz.

3.2 Radiated Emissions Limits

Frequency range (MHz)	Field strength (microvolts/meter)	Measure-ment dis-tance (meters)
0.009 to 0.490	2400/F(kHz)	300
0.490 to 1.705	24000/F(kHz)	30
1.705 to 30.0	30	30
30 to 88	100**	3
88 to 216	150**	3
216 to 960	200**	3
Above 960	500**	3

**Except as provided in paragraph (g), fundamental emissions from intentional radiators operating under this section shall not be located in the frequency bands 54–72 MHz, 76– 88 MHz, 174–216 MHz or 470–806 MHz. However, operation within these frequency bands is permitted under other sections of this part, e.g., §§15.231 and 15.241.

3.3 Test Equipment List

Describe	Manufacturer	Model	Serial Number	Calibration	
				Cal. Date	Due Date
Spectrum Analyzer	Agilent	E4408B	MY46181421	Mar. 13, 2009	Mar. 13, 2010
Pre Amplifier	Agilent	8449B	3008A02457	Mar. 04, 2009	Mar. 04, 2010
Pre Amplifier	Agilent	8447D	2944A11119	Jan. 19, 2009	Jan. 19, 2010
Test Receiver	R&S	ESCI	100367	Jun. 05, 2009	Jun. 05, 2010
Biconilog Antenna	SCHWARZBECK MESS-ELEKTRONIK	VULB9163	9163-270	Jun. 23, 2009	Jun. 23, 2010
Horn Antenna	SCHWARZBECK MESS-ELEKTRONIK	BBHA9120D	9120D-550	Jul. 01, 2009	Jul. 01, 2010
Horn Antenna	SCHWARZBECK MESS-ELEKTRONIK	BBHA9170	9170-320	Jun. 30, 2009	Jun. 30, 2010
Horn Antenna	SCHWARZBECK MESS-ELEKTRONIK	BBHA9120E	0899	Jun. 23, 2009	Jun. 23, 2010

3.4 Test Instruments Configuration

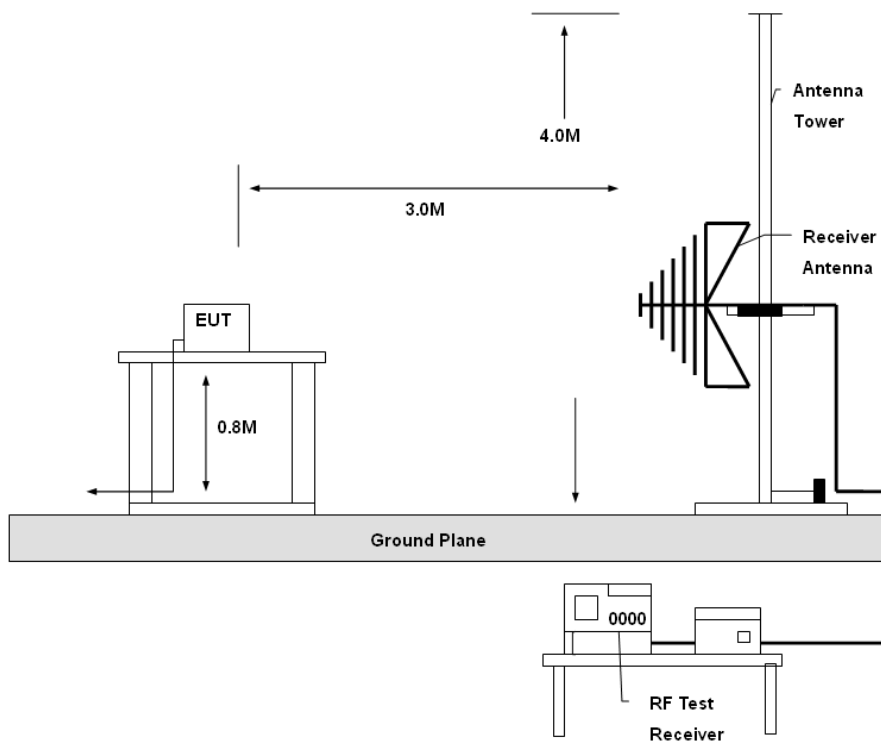



3.5 Test Results

EUT : Wireless 802.11b/g ADSL2+ Router

Model No. : TW263R4

Test Mode : IEEE 802.11b Link Mode

Test Date : 09/04/2009

Please refer to next page of detail testing data.

Notes:

1. Margin= Amplitude - Limits
2. Distance of Measurement: 3 Meter (30-1000MHz) & (1-10GHz), 1 Meter (10-26.5GHz)
3. Height of table for EUT placed: 0.8 Meter.
4. ANT= Antenna height.
5. Amplitude= Reading Amplitude – Amplifier gain + Cable loss + Antenna factor
(Auto calculate in spectrum analyzer)
6. The EUT was worst case on X axis after pretest on X & Y & Z axis setting.
7. The testing data only show below 18GHz's data because measure data above 18GHz was only ambient noise.
8. All frequencies from 30MHz to 26.5GHz have been tested



File :FCC(WIFI)

Data :#5

Date: 2009/9/4

Time: 上午 03:00:54

80.0 dBuV

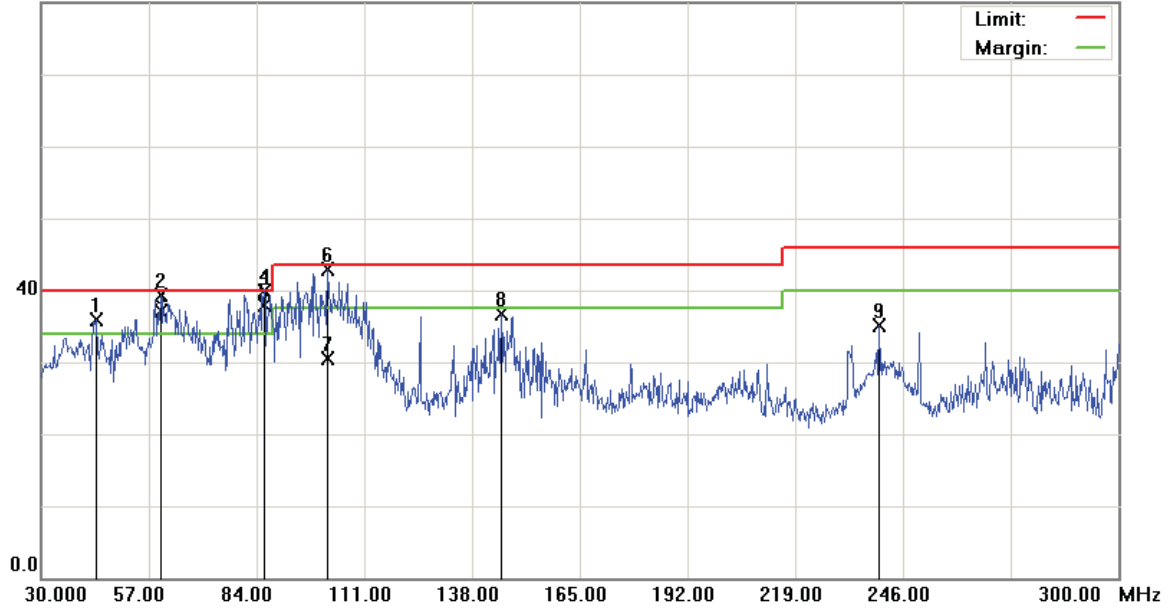

Site: site #1
 Limit: FCC Class B 3M Radiation
 EUT:
 M/N: 09-0216-EP
 Mode: IEEE 802.11b Link Mode
 Note:

Polarization: *Vertical*
 Power:
 Distance: 3m

Temperature: 22 °C
 Humidity: 60 %

No.	Mk.	Freq. MHz	Reading Level dBuV	Correct Factor dB	Measure- ment dBuV	Limit dBuV	Over dB	Antenna Height cm	Table Degree degree	Detector	Comment
1	!	43.7700	47.81	-11.84	35.97	40.00	-4.03			peak	
2	!	59.9700	51.87	-12.54	39.33	40.00	-0.67			peak	
3	!	59.9700	49.60	-12.54	37.06	40.00	-2.94			QP	
4	*	85.8900	54.31	-14.46	39.85	40.00	-0.15			peak	
5	!	85.8900	52.34	-14.46	37.88	40.00	-2.12			QP	
6	!	101.8200	54.86	-11.88	42.98	43.50	-0.52			peak	
7		101.8200	42.38	-11.88	30.50	43.50	-13.00			QP	
8		145.2900	52.81	-16.17	36.64	43.50	-6.86			peak	
9		240.0600	46.45	-11.43	35.02	46.00	-10.98			peak	

*:Maximum data x:Over limit !:over margin



File :FCC(WIFI)

Data :#6

Date: 2009/9/4

Time: 上午 03:05:08

80.0 dBuV

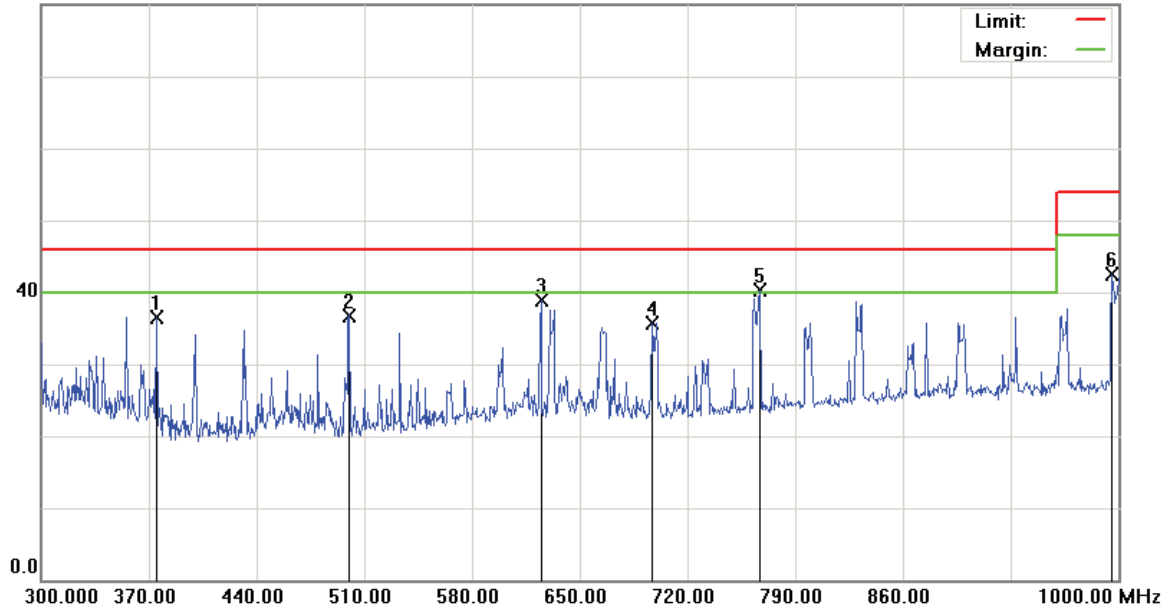

Site: site #1	Polarization: Vertical	Temperature: 22 °C
Limit: FCC Class B 3M Radiation	Power:	Humidity: 60 %
EUT:	Distance: 3m	
M/N: 09-0216-EP		
Mode: IEEE 802.11b Link Mode		
Note:		

No.	Mk.	Freq. MHz	Reading Level dBuV	Correct Factor dB	Measure- ment dBuV	Limit dBuV	Over dB	Antenna Height cm	Table Degree degree	Detector	Comment
1		374.9000	45.54	-8.95	36.59	46.00	-9.41			peak	
2		500.2000	43.97	-7.17	36.80	46.00	-9.20			peak	
3		624.8000	43.47	-4.64	38.83	46.00	-7.17			peak	
4		696.9000	39.52	-3.85	35.67	46.00	-10.33			peak	
5	*	766.9000	43.00	-2.75	40.25	46.00	-5.75			peak	
6		995.8000	41.72	0.75	42.47	54.00	-11.53			peak	

*:Maximum data x:Over limit !:over margin



File :FCC(2412MHz)

Data :#17

Date: 2009/9/4

Time: 上午 01:29:18

95.0 dBuV

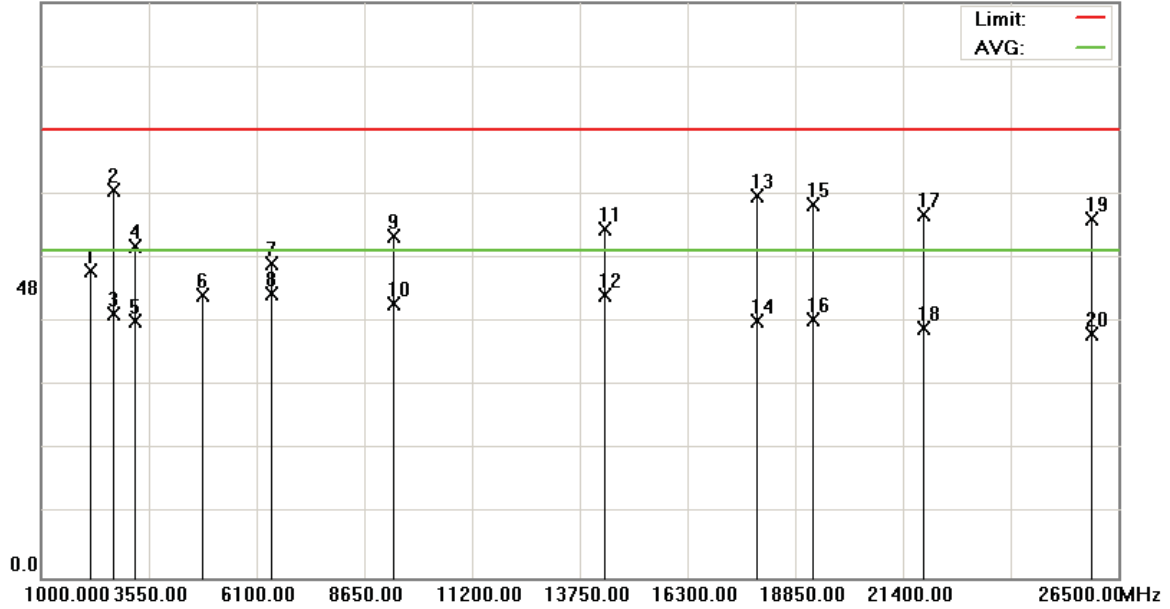

Site: site #1
 Limit: FCC part 15 (PK)
 EUT:
 M/N: 09-0216-EP
 Mode: IEEE 802.11b Link Mode
 Note: CH01(2412MHz)

Polarization: **Vertical**
 Power:
 Distance: 3m

Temperature: 22 °C
 Humidity: 60 %

No.	Mk.	Freq. MHz	Reading Level dBuV	Correct Factor dB	Measure- ment dBuV	Limit dBuV	Over dB	Antenna Height cm	Table Degree degree	Comment
1		2149.200	50.58	0.10	50.68	74.00	-23.32	peak		
2		2700.000	41.34	22.58	63.92	74.00	-10.08	peak		
3		2700.000	21.12	22.58	43.70	54.00	-10.30	AVG		
4		3211.000	51.84	2.85	54.69	74.00	-19.31	peak		
5		3211.000	39.45	2.85	42.30	54.00	-11.70	AVG		
6		4824.000	39.13	7.48	46.61	74.00	-27.39	peak		
7		6441.250	41.02	10.80	51.82	74.00	-22.18	peak		
8	*	6441.250	35.99	10.80	46.79	54.00	-7.21	AVG		
9		9324.750	39.43	16.91	56.34	74.00	-17.66	peak		
10		9324.750	28.39	16.91	45.30	54.00	-8.70	AVG		
11		14320.000	38.93	18.57	57.50	74.00	-16.50	peak		
12		14320.000	28.06	18.57	46.63	54.00	-7.37	AVG		
13		17920.000	38.33	24.84	63.17	74.00	-10.83	peak		
14		17920.000	17.56	24.84	42.40	54.00	-11.60	AVG		
15		19253.750	38.73	22.92	61.65	74.00	-12.35	peak		
16		19253.750	19.61	22.92	42.53	54.00	-11.47	AVG		
17		21867.500	38.68	21.19	59.87	74.00	-14.13	peak		
18		21867.500	19.90	21.19	41.09	54.00	-12.91	AVG		
19		25862.500	40.64	18.67	59.31	74.00	-14.69	peak		
20		25862.500	21.52	18.67	40.19	54.00	-13.81	AVG		

*:Maximum data x:Over limit !:over margin



File :FCC(2437MHz)

Data :#17

Date: 2009/9/4

Time: 上午 01:37:46

95.0 dBuV

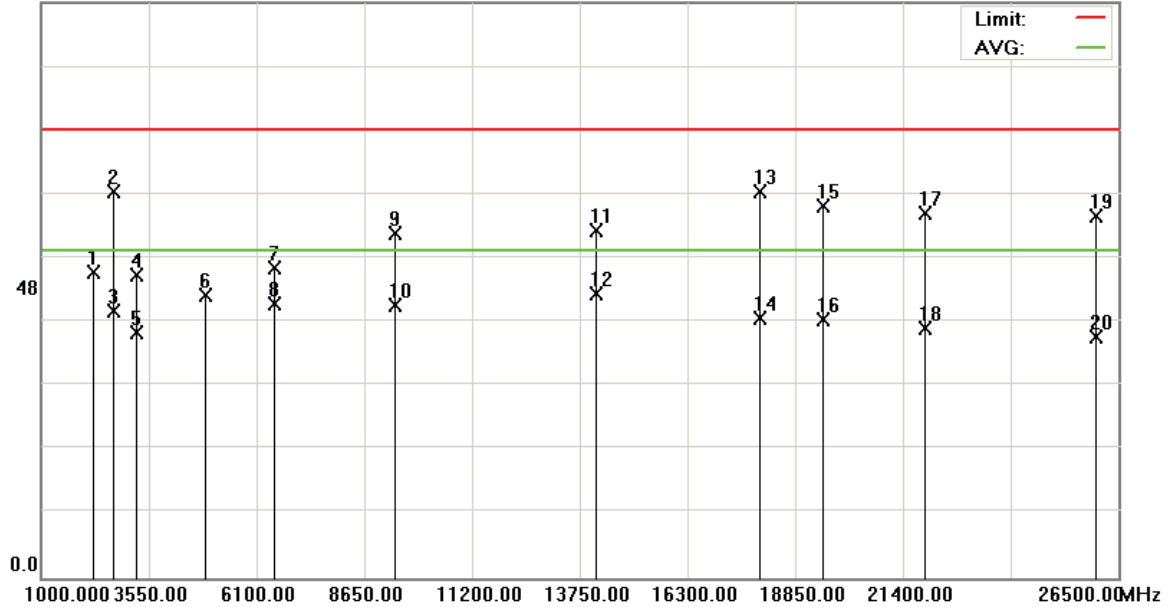

Site: site #1
 Limit: FCC part 15 (PK)
 EUT:
 M/N: 09-0216-EP
 Mode: IEEE 802.11b Link Mode
 Note: CH06(2437MHz)

Polarization: **Vertical**
 Power:
 Distance: 3m

Temperature: 22 °C
 Humidity: 60 %

No.	Mk.	Freq. MHz	Reading Level dBuV	Correct Factor dB	Measure- ment dBuV	Limit dBuV	Over dB	Antenna Height cm	Table Degree degree	Detector	Comment
1		2239.300	50.12	0.43	50.55	74.00	-23.45			peak	
2		2700.000	41.09	22.58	63.67	74.00	-10.33			peak	
3		2700.000	21.48	22.58	44.06	54.00	-9.94			AVG	
4		3247.500	47.54	2.41	49.95	74.00	-24.05			peak	
5		3247.500	38.13	2.41	40.54	54.00	-13.46			AVG	
6		4874.000	38.86	7.72	46.58	74.00	-27.42			peak	
7		6496.000	40.25	10.95	51.20	74.00	-22.80			peak	
8		6496.000	34.22	10.95	45.17	54.00	-8.83			AVG	
9		9361.250	39.91	16.98	56.89	74.00	-17.11			peak	
10		9361.250	27.92	16.98	44.90	54.00	-9.10			AVG	
11		14120.000	38.44	18.87	57.31	74.00	-16.69			peak	
12	*	14120.000	27.98	18.87	46.85	54.00	-7.15			AVG	
13		18000.000	38.25	25.57	63.82	74.00	-10.18			peak	
14		18000.000	17.28	25.57	42.85	54.00	-11.15			AVG	
15		19508.750	38.59	22.69	61.28	74.00	-12.72			peak	
16		19508.750	20.03	22.69	42.72	54.00	-11.28			AVG	
17		21888.750	39.11	21.18	60.29	74.00	-13.71			peak	
18		21888.750	19.92	21.18	41.10	54.00	-12.90			AVG	
19		25947.500	41.21	18.60	59.81	74.00	-14.19			peak	
20		25947.500	21.10	18.60	39.70	54.00	-14.30			AVG	

*:Maximum data x:Over limit !:over margin



File :FCC(2462MHz)

Data :#17

Date: 2009/9/4

Time: 上午 01:44:05

95.0 dBuV

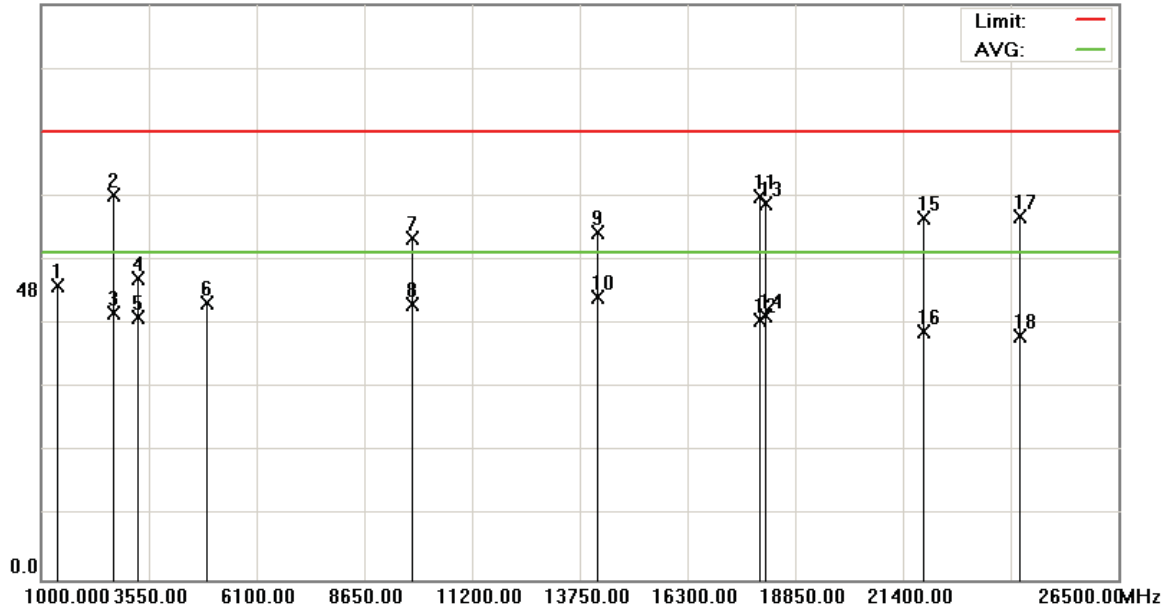

Site: site #1
 Limit: FCC part 15 (PK)
 EUT:
 M/N: 09-0216-EP
 Mode: IEEE 802.11b Link Mode
 Note: CH11(2462MHz)

Polarization: **Vertical**
 Power:
 Distance: 3m

Temperature: 22 °C
 Humidity: 60 %

No.	Mk.	Freq. MHz	Reading Level dBuV	Correct Factor dB	Measure- ment dBuV	Limit dBuV	Over dB	Antenna Height cm	Table Degree degree	Degree Comment
1		1363.800	52.31	-3.68	48.63	74.00	-25.37	peak		
2		2700.000	41.06	22.58	63.64	74.00	-10.36	peak		
3		2700.000	21.43	22.58	44.01	54.00	-9.99	AVG		
4		3284.000	47.35	2.37	49.72	74.00	-24.28	peak		
5		3284.000	40.89	2.37	43.26	54.00	-10.74	AVG		
6		4924.000	38.07	7.65	45.72	74.00	-28.28	peak		
7		9781.000	38.72	17.69	56.41	74.00	-17.59	peak		
8		9781.000	27.84	17.69	45.53	54.00	-8.47	AVG		
9		14160.000	38.45	18.83	57.28	74.00	-16.72	peak		
10	*	14160.000	27.91	18.83	46.74	54.00	-7.26	AVG		
11		18000.000	37.81	25.57	63.38	74.00	-10.62	peak		
12		18000.000	17.29	25.57	42.86	54.00	-11.14	AVG		
13		18127.500	38.83	23.23	62.06	74.00	-11.94	peak		
14		18127.500	20.30	23.23	43.53	54.00	-10.47	AVG		
15		21867.500	38.55	21.19	59.74	74.00	-14.26	peak		
16		21867.500	19.75	21.19	40.94	54.00	-13.06	AVG		
17		24162.500	39.99	19.88	59.87	74.00	-14.13	peak		
18		24162.500	20.26	19.88	40.14	54.00	-13.86	AVG		

*:Maximum data x:Over limit !:over margin



File :FCC(WIFI)

Data :#7

Date: 2009/9/4

Time: 上午 03:09:21

80.0 dBuV

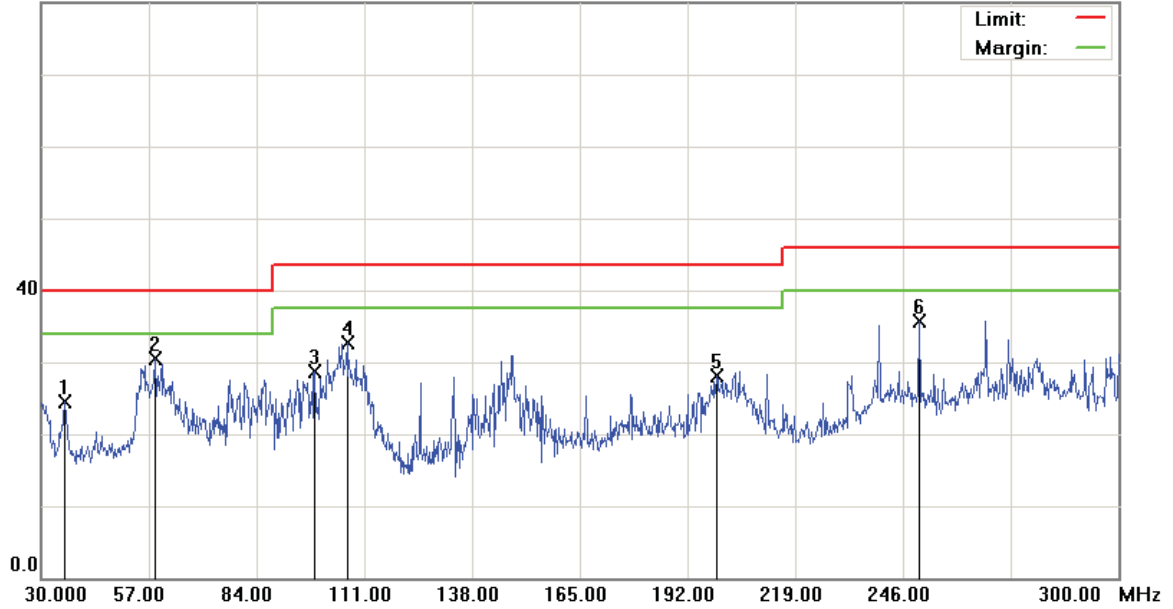

Site: site #1
 Limit: FCC Class B 3M Radiation
 EUT:
 M/N: 09-0216-EP
 Mode: IEEE 802.11b Link Mode
 Note:

Polarization: *Horizontal*
 Power:
 Distance: 3m

Temperature: 22 °C
 Humidity: 60 %

No.	Mk.	Freq. MHz	Reading Level dBuV	Correct Factor dB	Measure- ment dBuV	Limit dBuV	Over dB	Antenna Height cm	Table Degree degree	Detector	Comment
1		35.9400	37.49	-12.95	24.54	40.00	-15.46			peak	
2	*	58.6200	42.96	-12.45	30.51	40.00	-9.49			peak	
3		98.5800	40.51	-11.84	28.67	43.50	-14.83			peak	
4		106.6800	45.03	-12.23	32.80	43.50	-10.70			peak	
5		199.2900	41.33	-13.17	28.16	43.50	-15.34			peak	
6		250.0500	46.58	-10.82	35.76	46.00	-10.24			peak	

*:Maximum data x:Over limit !:over margin



File :FCC(WIFI)

Data :#8

Date: 2009/9/4

Time: 上午 03:13:36

80.0 dBuV

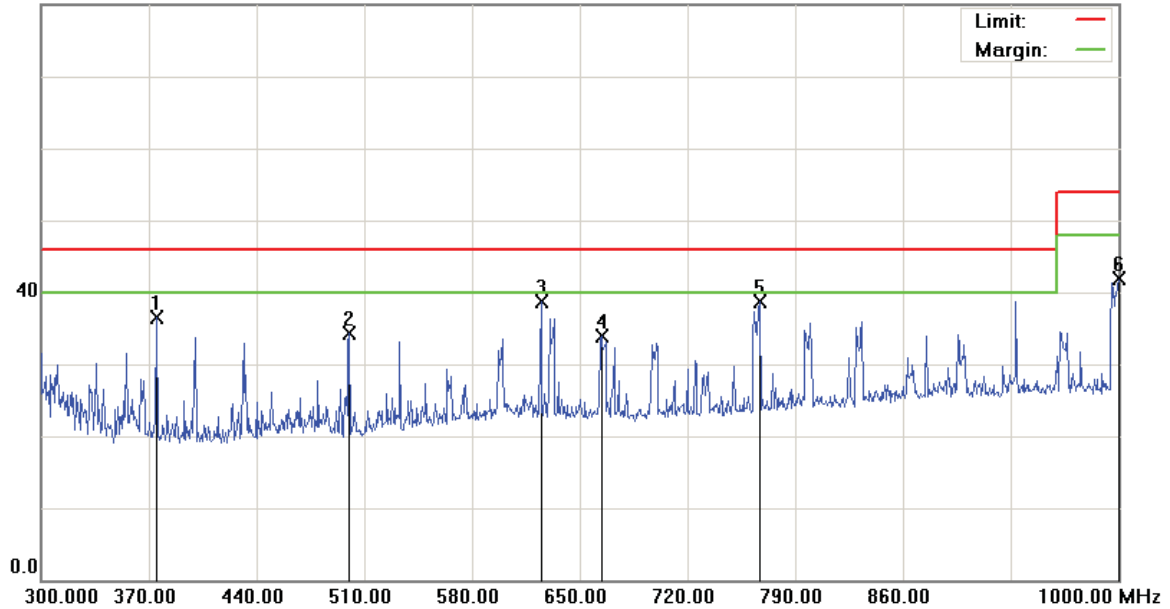

Site: site #1
 Limit: FCC Class B 3M Radiation
 EUT:
 M/N: 09-0216-EP
 Mode: IEEE 802.11b Link Mode
 Note:

Polarization: *Horizontal*
 Power:
 Distance: 3m

Temperature: 22 °C
 Humidity: 60 %

No.	Mk.	Freq. MHz	Reading Level dBuV	Correct Factor dB	Measure- ment dBuV	Limit dBuV	Over dB	Antenna Height cm	Table Degree degree	Detector	Comment
1		374.9000	45.40	-8.95	36.45	46.00	-9.55			peak	
2		500.2000	41.50	-7.17	34.33	46.00	-11.67			peak	
3	*	624.8000	43.36	-4.64	38.72	46.00	-7.28			peak	
4		664.0000	38.32	-4.43	33.89	46.00	-12.11			peak	
5		766.9000	41.43	-2.75	38.68	46.00	-7.32			peak	
6		1000.0000	41.24	0.62	41.86	54.00	-12.14			peak	

*:Maximum data x:Over limit !:over margin



File :FCC(2412MHz)

Data :#18

Date: 2009/9/4

Time: 上午 01:32:51

95.0 dBuV

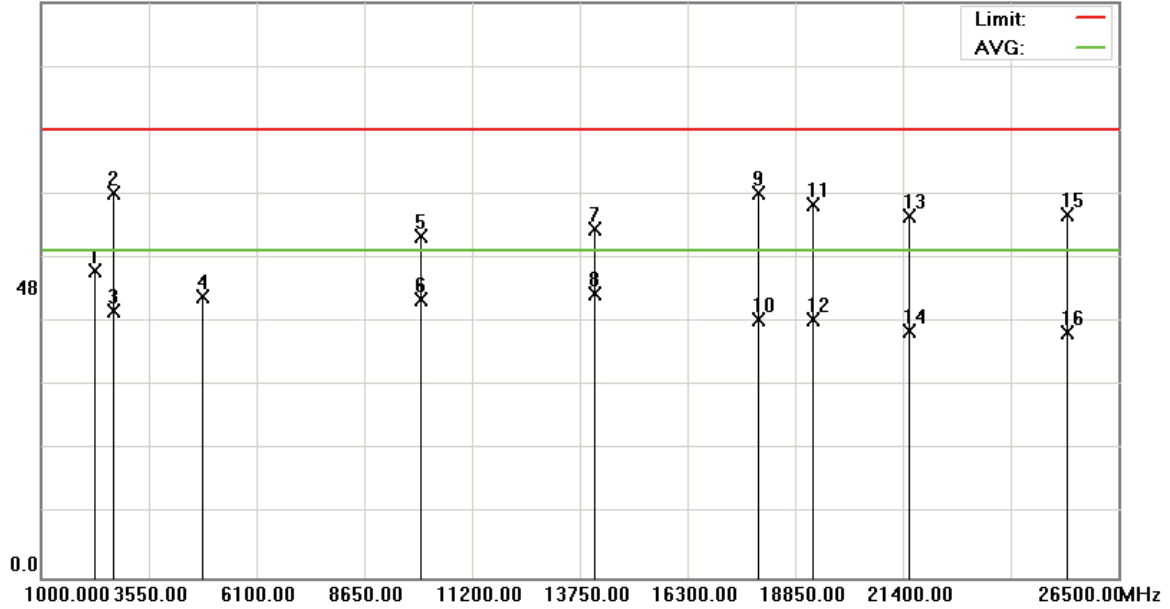

Site: site #1
 Limit: FCC part 15 (PK)
 EUT:
 M/N: 09-0216-EP
 Mode: IEEE 802.11b Link Mode
 Note: CH01(2412MHz)

Polarization: **Horizontal**
 Power:
 Distance: 3m

Temperature: 22 °C
 Humidity: 60 %

No.	Mk.	Freq. MHz	Reading Level dBuV	Correct Factor dB	Measurement dBuV	Limit dBuV	Over dB	Antenna Height cm	Table Degree degree	Comment
1		2263.100	50.25	0.45	50.70	74.00	-23.30			peak
2		2700.000	40.93	22.58	63.51	74.00	-10.49			peak
3		2700.000	21.37	22.58	43.95	54.00	-10.05			AVG
4		4824.000	38.98	7.48	46.46	74.00	-27.54			peak
5		10000.000	38.48	17.94	56.42	74.00	-17.58			peak
6		10000.000	27.94	17.94	45.88	54.00	-8.12			AVG
7		14100.000	38.70	18.90	57.60	74.00	-16.40			peak
8	*	14100.000	27.91	18.90	46.81	54.00	-7.19			AVG
9		17980.000	38.25	25.21	63.46	74.00	-10.54			peak
10		17980.000	17.44	25.21	42.65	54.00	-11.35			AVG
11		19275.000	38.69	22.91	61.60	74.00	-12.40			peak
12		19275.000	19.73	22.91	42.64	54.00	-11.36			AVG
13		21548.750	38.52	21.33	59.85	74.00	-14.15			peak
14		21548.750	19.42	21.33	40.75	54.00	-13.25			AVG
15		25288.750	40.87	19.11	59.98	74.00	-14.02			peak
16		25288.750	21.31	19.11	40.42	54.00	-13.58			AVG

*:Maximum data x:Over limit !:over margin



File :FCC(2437MHz)

Data :#18

Date: 2009/9/4

Time: 上午 01:41:11

95.0 dBuV

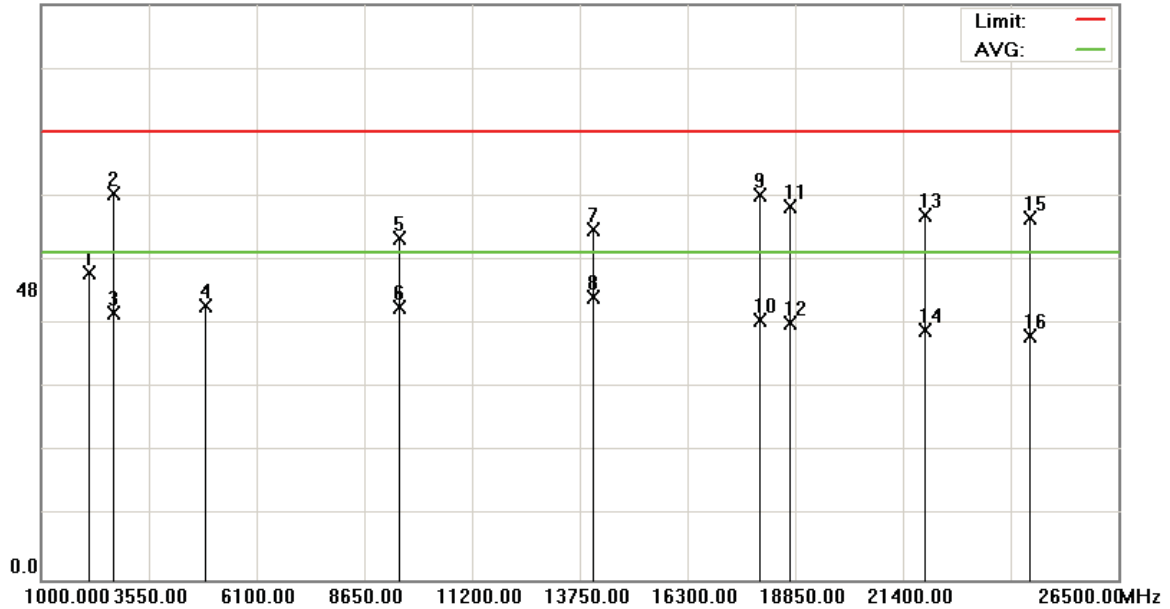

Site: site #1
 Limit: FCC part 15 (PK)
 EUT:
 M/N: 09-0216-EP
 Mode: IEEE 802.11b Link Mode
 Note: CH06(2437MHz)

Polarization: **Horizontal**
 Power:
 Distance: 3m

Temperature: 22 °C
 Humidity: 60 %

No.	Mk.	Freq. MHz	Reading Level dBuV	Correct Factor dB	Measure- ment dBuV	Limit dBuV	Over dB	Antenna Height cm	Table Degree degree	Detector	Comment
1		2123.700	51.09	-0.29	50.80	74.00	-23.20			peak	
2		2700.000	41.25	22.58	63.83	74.00	-10.17			peak	
3		2700.000	21.40	22.58	43.98	54.00	-10.02			AVG	
4		4874.000	37.61	7.72	45.33	74.00	-28.67			peak	
5		9452.500	39.43	17.00	56.43	74.00	-17.57			peak	
6		9452.500	27.89	17.00	44.89	54.00	-9.11			AVG	
7		14080.000	39.05	18.81	57.86	74.00	-16.14			peak	
8	*	14080.000	27.90	18.81	46.71	54.00	-7.29			AVG	
9		18000.000	37.96	25.57	63.53	74.00	-10.47			peak	
10		18000.000	17.27	25.57	42.84	54.00	-11.16			AVG	
11		18722.500	38.42	23.12	61.54	74.00	-12.46			peak	
12		18722.500	19.21	23.12	42.33	54.00	-11.67			AVG	
13		21888.750	38.93	21.18	60.11	74.00	-13.89			peak	
14		21888.750	19.98	21.18	41.16	54.00	-12.84			AVG	
15		24396.250	40.12	19.72	59.84	74.00	-14.16			peak	
16		24396.250	20.48	19.72	40.20	54.00	-13.80			AVG	

*:Maximum data x:Over limit !:over margin



File :FCC(2462MHz)

Data :#18

Date: 2009/9/4

Time: 上午 01:47:38

95.0 dBuV

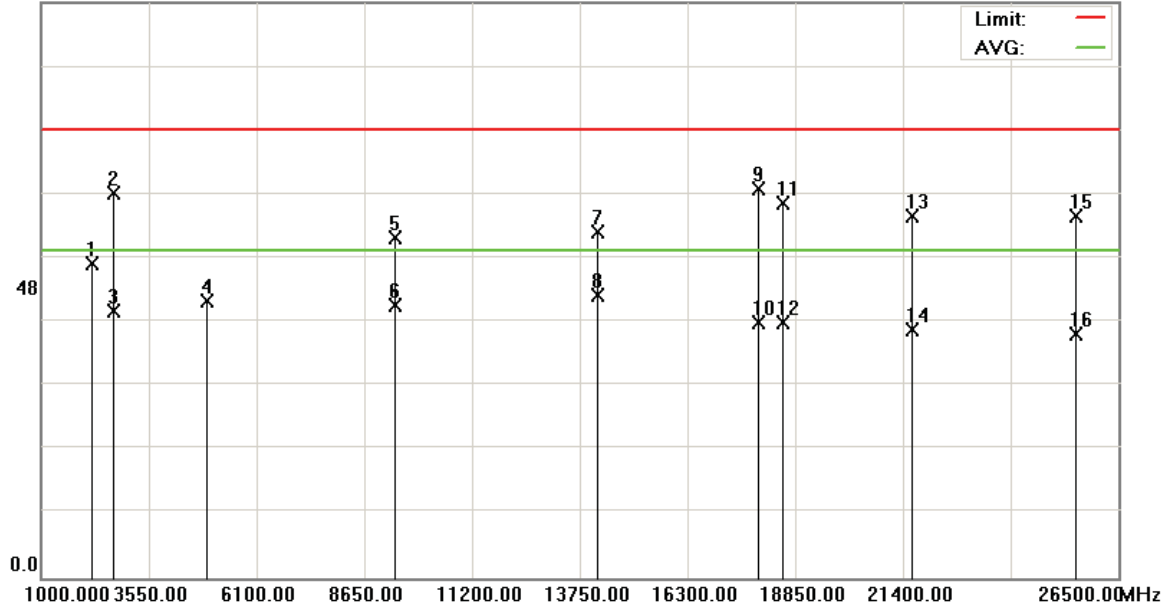

Site: site #1
 Limit: FCC part 15 (PK)
 EUT:
 M/N: 09-0216-EP
 Mode: IEEE 802.11b Link Mode
 Note: CH11(2462MHz)

Polarization: **Horizontal**
 Power:
 Distance: 3m

Temperature: 22 °C
 Humidity: 60 %

No.	Mk.	Freq. MHz	Reading Level dBuV	Correct Factor dB	Measure- ment dBuV	Limit dBuV	Over dB	Antenna Height cm	Table Degree degree	Comment
1		2181.500	51.61	0.26	51.87	74.00	-22.13	peak		
2		2700.000	40.99	22.58	63.57	74.00	-10.43	peak		
3		2700.000	21.39	22.58	43.97	54.00	-10.03	AVG		
4		4924.000	37.97	7.65	45.62	74.00	-28.38	peak		
5		9343.000	39.23	16.93	56.16	74.00	-17.84	peak		
6		9343.000	28.13	16.93	45.06	54.00	-8.94	AVG		
7		14180.000	28.67	28.39	57.06	74.00	-16.94	peak		
8	*	14180.000	18.38	28.39	46.77	54.00	-7.23	AVG		
9		17960.000	29.78	34.38	64.16	74.00	-9.84	peak		
10		17960.000	7.79	34.38	42.17	54.00	-11.83	AVG		
11		18552.500	38.69	23.08	61.77	74.00	-12.23	peak		
12		18552.500	19.05	23.08	42.13	54.00	-11.87	AVG		
13		21591.250	38.51	21.30	59.81	74.00	-14.19	peak		
14		21591.250	19.66	21.30	40.96	54.00	-13.04	AVG		
15		25501.250	40.83	18.98	59.81	74.00	-14.19	peak		
16		25501.250	21.21	18.98	40.19	54.00	-13.81	AVG		

*:Maximum data x:Over limit !:over margin



EUT : Wireless 802.11b/g ADSL2+ Router
Model No. : TW263R4
Test Mode : IEEE 802.11g Link Mode
Test Date : 09/04/2009

Please refer to next page of detail testing data.

Notes:

1. Margin= Amplitude - Limits
2. Distance of Measurement: 3 Meter (30-1000MHz) & (1-10GHz), 1 Meter (10-26.5GHz)
3. Height of table for EUT placed: 0.8 Meter.
4. ANT= Antenna height.
5. Amplitude= Reading Amplitude – Amplifier gain + Cable loss + Antenna factor
(Auto calculate in spectrum analyzer)
6. The EUT was worst case on X axis after pretest on X & Y & Z axis setting.
7. The testing data only show below 18GHz's data because measure data above 18GHz was only ambient noise.
8. All frequencies from 30MHz to 26.5GHz have been tested



File :FCC(WIFI)

Data :#5

Date: 2009/9/4

Time: 上午 03:00:54

80.0 dBuV

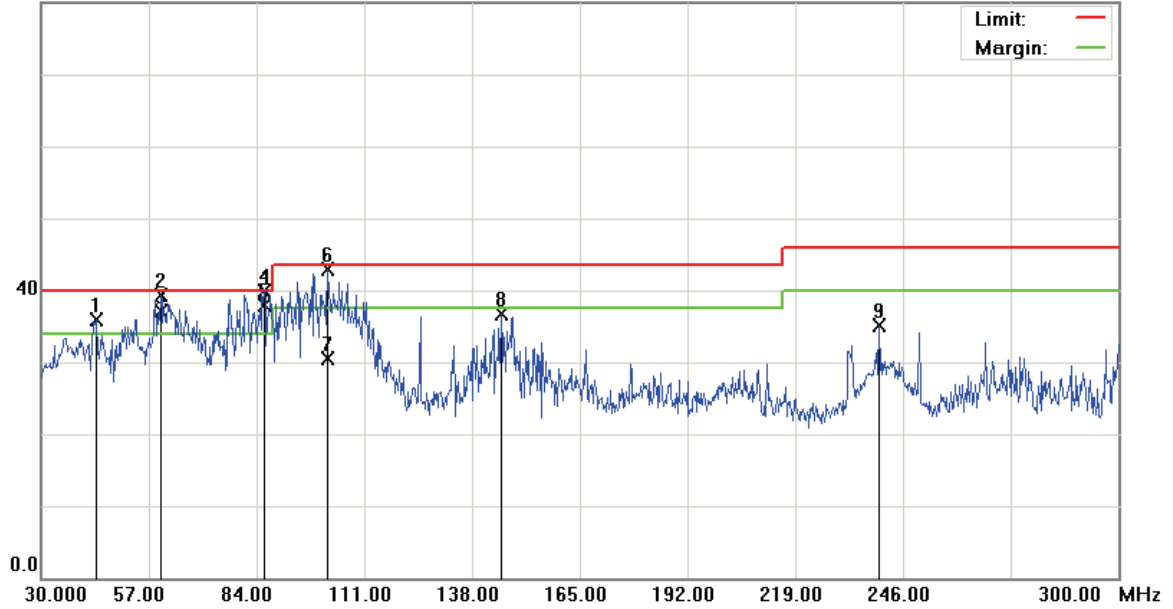

Site: site #1

Polarization: *Vertical*

Temperature: 22 °C

Limit: FCC Class B 3M Radiation

Power:

Humidity: 60 %

EUT:

Distance: 3m

M/N: 09-0216-EP

Mode: IEEE 802.11g Link Mode

Note:

No.	Mk.	Freq. MHz	Reading Level dBuV	Correct Factor dB	Measure- ment dBuV	Limit dBuV	Over dB	Antenna Height cm	Table Degree degree	Detector	Comment
1	!	43.7700	47.81	-11.84	35.97	40.00	-4.03			peak	
2	!	59.9700	51.87	-12.54	39.33	40.00	-0.67			peak	
3	!	59.9700	49.60	-12.54	37.06	40.00	-2.94			QP	
4	*	85.8900	54.31	-14.46	39.85	40.00	-0.15			peak	
5	!	85.8900	52.34	-14.46	37.88	40.00	-2.12			QP	
6	!	101.8200	54.86	-11.88	42.98	43.50	-0.52			peak	
7		101.8200	42.38	-11.88	30.50	43.50	-13.00			QP	
8		145.2900	52.81	-16.17	36.64	43.50	-6.86			peak	
9		240.0600	46.45	-11.43	35.02	46.00	-10.98			peak	

*:Maximum data x:Over limit !:over margin



File :FCC(WIFI)

Data :#6

Date: 2009/9/4

Time: 上午 03:05:08

80.0 dBuV

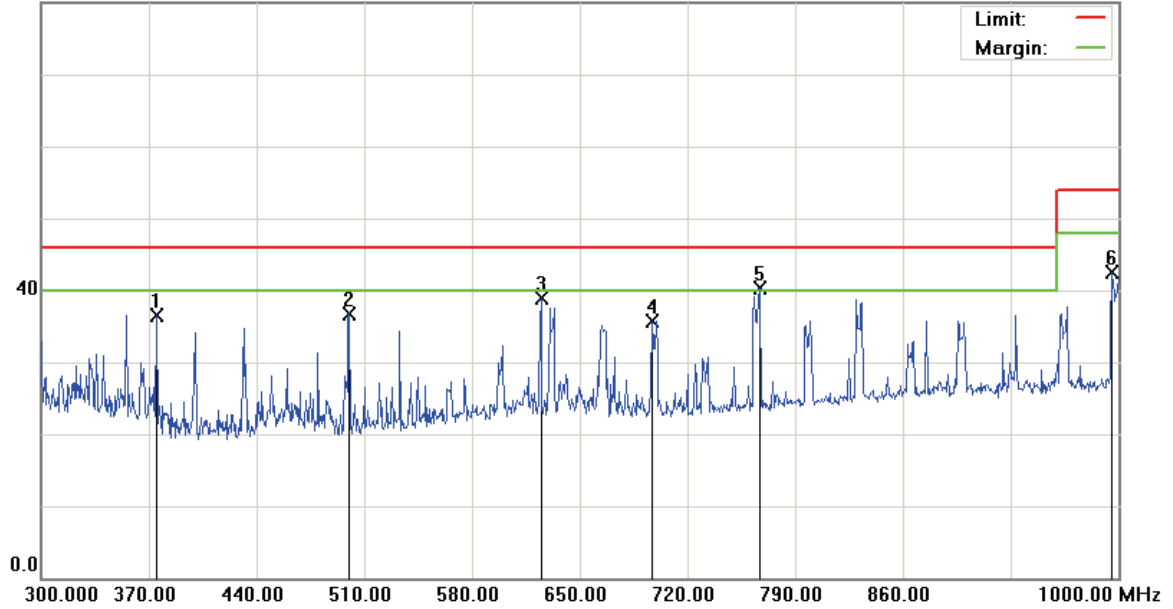

Site: site #1

Polarization: **Vertical**

Temperature: 22 °C

Limit: FCC Class B 3M Radiation

Power:

Humidity: 60 %

EUT:

Distance: 3m

M/N: 09-0216-EP

Mode: IEEE 802.11g Link Mode

Note:

No.	Mk.	Freq. MHz	Reading Level dBuV	Correct Factor dB	Measure- ment dBuV	Limit dBuV	Over dB	Antenna Height cm	Table Degree degree	Detector	Comment
1		374.9000	45.54	-8.95	36.59	46.00	-9.41			peak	
2		500.2000	43.97	-7.17	36.80	46.00	-9.20			peak	
3		624.8000	43.47	-4.64	38.83	46.00	-7.17			peak	
4		696.9000	39.52	-3.85	35.67	46.00	-10.33			peak	
5	*	766.9000	43.00	-2.75	40.25	46.00	-5.75			peak	
6		995.8000	41.72	0.75	42.47	54.00	-11.53			peak	

*:Maximum data x:Over limit !:over margin



File :FCC(2412MHz)

Data :#17

Date: 2009/9/4

Time: 上午 12:52:30

95.0 dBuV

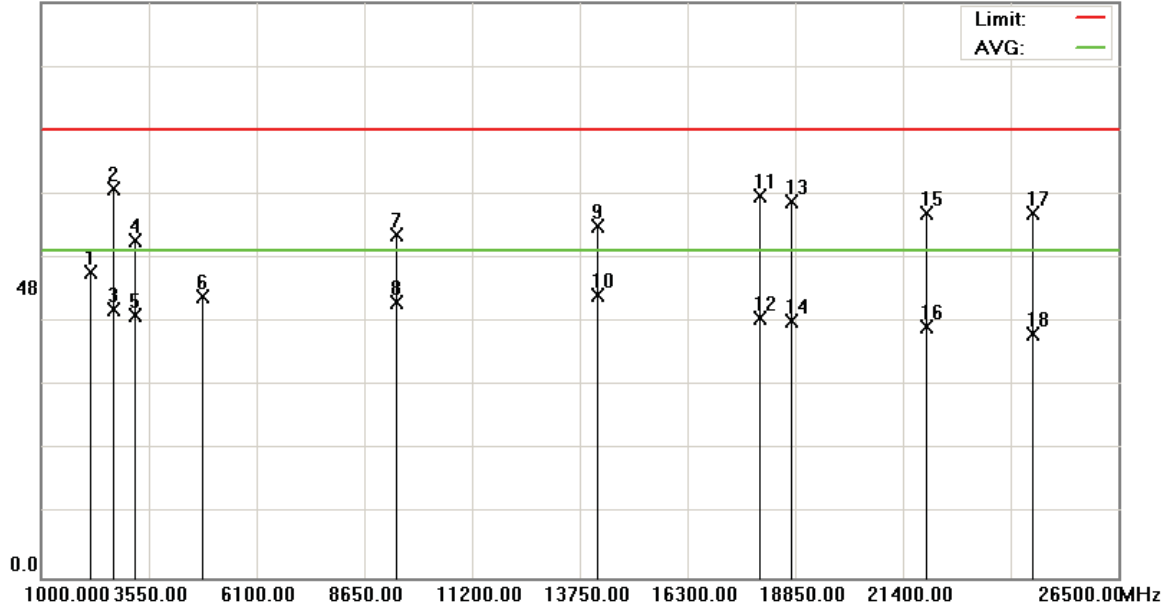

Site: site #1
 Limit: FCC part 15 (PK)
 EUT:
 M/N: 09-0216-EP
 Mode: IEEE 802.11g Link Mode
 Note: CH01(2412MHz)

Polarization: **Vertical**
 Power:
 Distance: 3m

Temperature: 22 °C
 Humidity: 60 %

No.	Mk.	Freq. MHz	Reading Level dBuV	Correct Factor dB	Measure- ment dBuV	Limit dBuV	Over dB	Antenna Height cm	Table Degree degree	Comment
1		2169.600	50.31	0.16	50.47	74.00	-23.53	peak		
2		2700.000	41.57	22.58	64.15	74.00	-9.85	peak		
3		2700.000	21.83	22.58	44.41	54.00	-9.59	AVG		
4		3211.000	52.80	2.85	55.65	74.00	-18.35	peak		
5		3211.000	40.53	2.85	43.38	54.00	-10.62	AVG		
6		4824.000	38.96	7.48	46.44	74.00	-27.56	peak		
7		9397.750	39.59	17.08	56.67	74.00	-17.33	peak		
8		9397.750	28.34	17.08	45.42	54.00	-8.58	AVG		
9		14180.000	39.16	18.85	58.01	74.00	-15.99	peak		
10	*	14180.000	27.93	18.85	46.78	54.00	-7.22	AVG		
11		18000.000	37.59	25.57	63.16	74.00	-10.84	peak		
12		18000.000	17.29	25.57	42.86	54.00	-11.14	AVG		
13		18765.000	38.93	23.13	62.06	74.00	-11.94	peak		
14		18765.000	19.26	23.13	42.39	54.00	-11.61	AVG		
15		21952.500	38.94	21.15	60.09	74.00	-13.91	peak		
16		21952.500	20.28	21.15	41.43	54.00	-12.57	AVG		
17		24438.750	40.50	19.69	60.19	74.00	-13.81	peak		
18		24438.750	20.67	19.69	40.36	54.00	-13.64	AVG		

*:Maximum data x:Over limit !:over margin



File :FCC(2437MHz)

Data :#17

Date: 2009/9/4

Time: 上午 12:47:29

95.0 dBuV

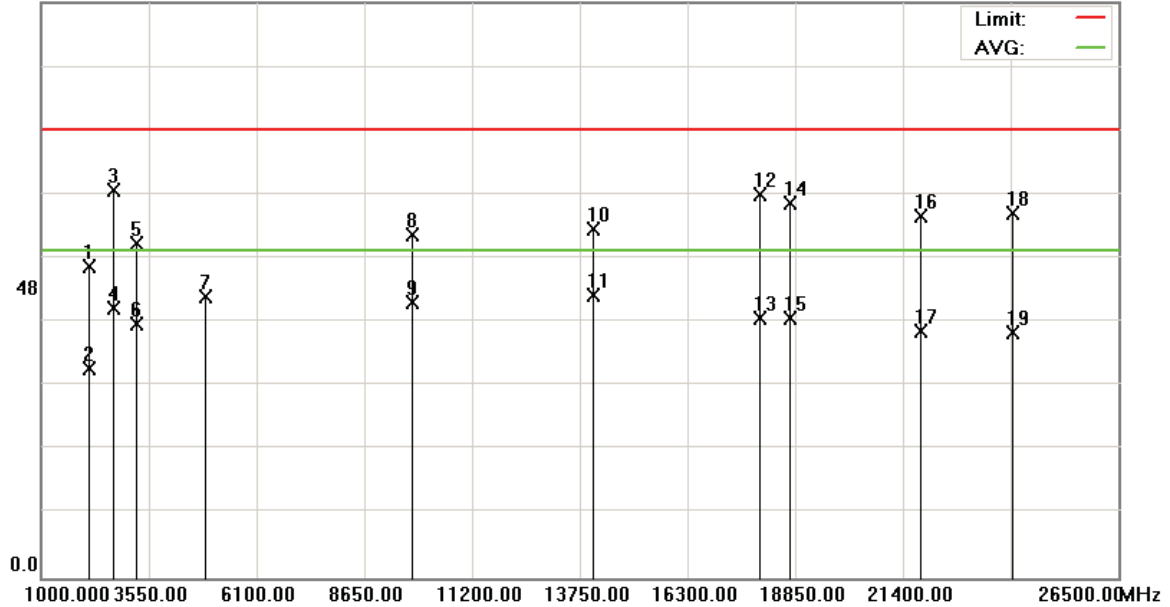

Site: site #1
 Limit: FCC part 15 (PK)
 EUT:
 M/N: 09-0216-EP
 Mode: IEEE 802.11g Link Mode
 Note: CH06(2437MHz)

Polarization: **Vertical**
 Power:
 Distance: 3m

Temperature: 22 °C
 Humidity: 60 %

No.	Mk.	Freq. MHz	Reading Level dBuV	Correct Factor dB	Measure- ment dBuV	Limit dBuV	Over dB	Antenna Height cm	Table Degree degree	Detector	Comment
1		2144.100	51.42	-0.01	51.41	74.00	-22.59			peak	
2		2144.100	34.64	-0.01	34.63	54.00	-19.37			AVG	
3		2700.000	41.48	22.58	64.06	74.00	-9.94			peak	
4		2700.000	21.89	22.58	44.47	54.00	-9.53			AVG	
5		3247.500	52.74	2.41	55.15	74.00	-18.85			peak	
6		3247.500	39.43	2.41	41.84	54.00	-12.16			AVG	
7		4874.000	38.64	7.72	46.36	74.00	-27.64			peak	
8		9762.750	38.89	17.70	56.59	74.00	-17.41			peak	
9		9762.750	27.71	17.70	45.41	54.00	-8.59			AVG	
10		14080.000	29.14	28.35	57.49	74.00	-16.51			peak	
11	*	14080.000	18.31	28.35	46.66	54.00	-7.34			AVG	
12		18000.000	28.10	35.11	63.21	74.00	-10.79			peak	
13		18000.000	7.76	35.11	42.87	54.00	-11.13			AVG	
14		18722.500	38.78	23.12	61.90	74.00	-12.10			peak	
15		18722.500	19.74	23.12	42.86	54.00	-11.14			AVG	
16		21803.750	38.55	21.21	59.76	74.00	-14.24			peak	
17		21803.750	19.57	21.21	40.78	54.00	-13.22			AVG	
18		23992.500	40.21	20.03	60.24	74.00	-13.76			peak	
19		23992.500	20.49	20.03	40.52	54.00	-13.48			AVG	

*:Maximum data x:Over limit !:over margin



File :FCC(2462MHz)

Data :#17

Date: 2009/9/4

Time: 上午 12:36:48

95.0 dBuV

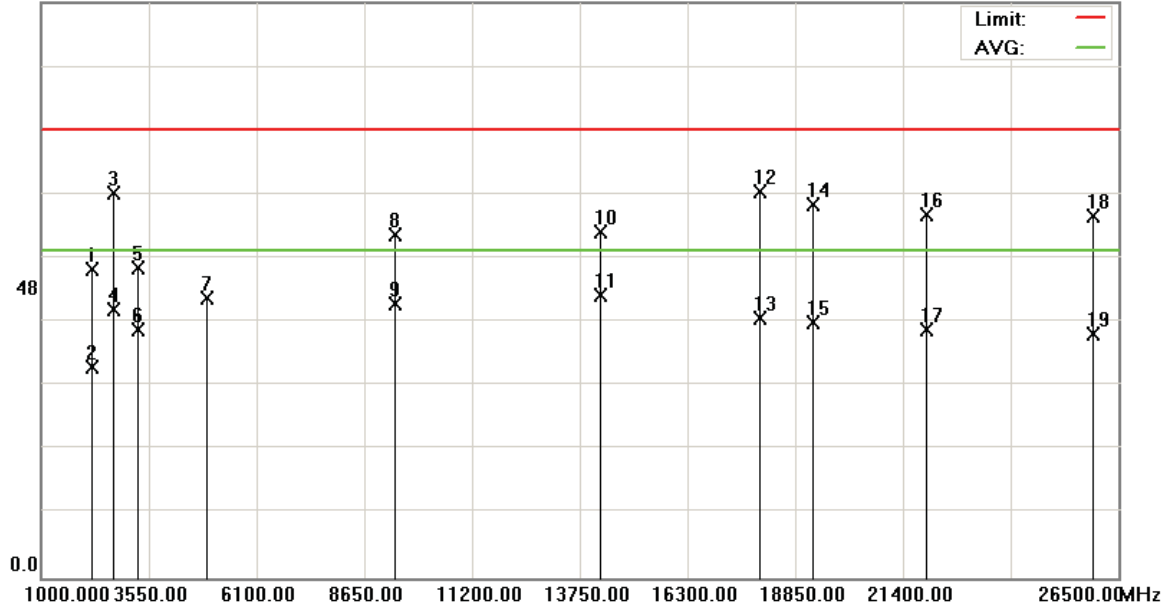

Site: site #1
 Limit: FCC part 15 (PK)
 EUT:
 M/N: 09-0216-EP
 Mode: IEEE 802.11g Link Mode
 Note: CH11(2462MHz)

Polarization: **Vertical**
 Power:
 Distance: 3m

Temperature: 22 °C
 Humidity: 60 %

No.	Mk.	Freq. MHz	Reading Level dBuV	Correct Factor dB	Measure- ment dBuV	Limit dBuV	Over dB	Antenna Height cm	Table Degree degree	Detector	Comment
1		2181.500	50.79	0.26	51.05	74.00	-22.95			peak	
2		2181.500	34.59	0.26	34.85	54.00	-19.15			AVG	
3		2700.000	41.07	22.58	63.65	74.00	-10.35			peak	
4		2700.000	21.65	22.58	44.23	54.00	-9.77			AVG	
5		3284.000	48.83	2.37	51.20	74.00	-22.80			peak	
6		3284.000	38.62	2.37	40.99	54.00	-13.01			AVG	
7		4924.000	38.54	7.65	46.19	74.00	-27.81			peak	
8		9361.250	39.61	16.98	56.59	74.00	-17.41			peak	
9		9361.250	28.32	16.98	45.30	54.00	-8.70			AVG	
10		14220.000	38.44	18.78	57.22	74.00	-16.78			peak	
11	*	14220.000	27.93	18.78	46.71	54.00	-7.29			AVG	
12		18000.000	38.31	25.57	63.88	74.00	-10.12			peak	
13		18000.000	17.30	25.57	42.87	54.00	-11.13			AVG	
14		19275.000	38.78	22.91	61.69	74.00	-12.31			peak	
15		19275.000	19.21	22.91	42.12	54.00	-11.88			AVG	
16		21952.500	38.86	21.15	60.01	74.00	-13.99			peak	
17		21952.500	19.87	21.15	41.02	54.00	-12.98			AVG	
18		25883.750	41.02	18.65	59.67	74.00	-14.33			peak	
19		25883.750	21.71	18.65	40.36	54.00	-13.64			AVG	

*:Maximum data x:Over limit !:over margin



File :FCC(WIFI)

Data :#7

Date: 2009/9/4

Time: 上午 03:09:21

80.0 dBuV

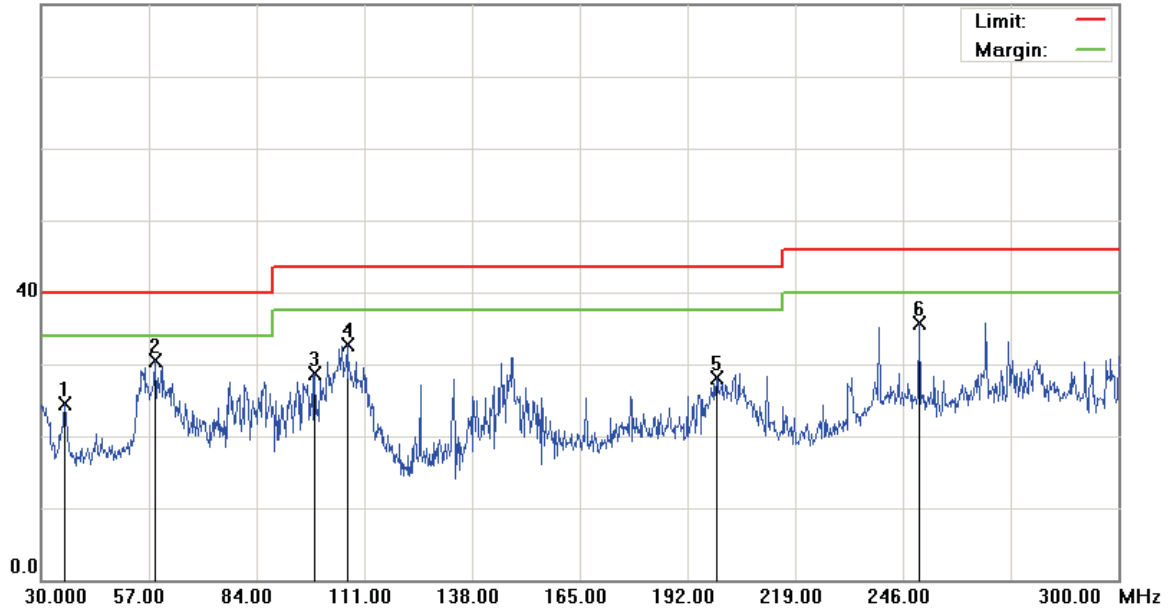

Site: site #1

Polarization: *Horizontal*

Temperature: 22 °C

Limit: FCC Class B 3M Radiation

Power:

Humidity: 60 %

EUT:

Distance: 3m

M/N: 09-0216-EP

Mode: IEEE 802.11g Link Mode

Note:

No.	Mk.	Freq. MHz	Reading Level dBuV	Correct Factor dB	Measure- ment dBuV	Limit dBuV	Over dB	Antenna Height cm	Table Degree degree	Detector	Comment
1		35.9400	37.49	-12.95	24.54	40.00	-15.46			peak	
2	*	58.6200	42.96	-12.45	30.51	40.00	-9.49			peak	
3		98.5800	40.51	-11.84	28.67	43.50	-14.83			peak	
4		106.6800	45.03	-12.23	32.80	43.50	-10.70			peak	
5		199.2900	41.33	-13.17	28.16	43.50	-15.34			peak	
6		250.0500	46.58	-10.82	35.76	46.00	-10.24			peak	

*:Maximum data x:Over limit !:over margin



File :FCC(WIFI)

Data :#8

Date: 2009/9/4

Time: 上午 03:13:36

80.0 dBuV

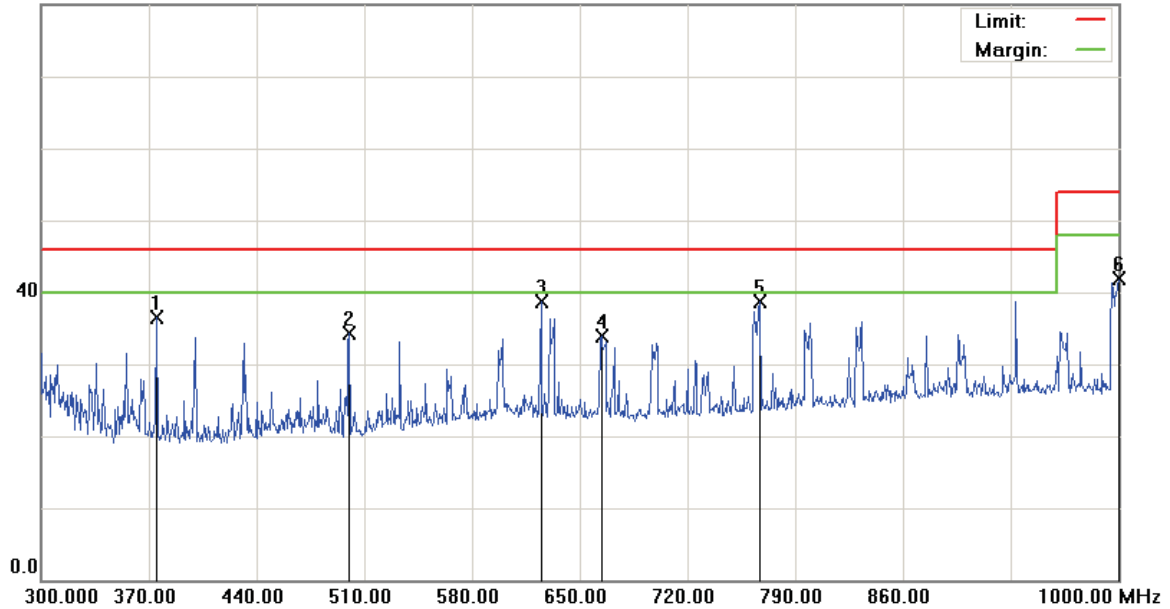

Site: site #1

Polarization: *Horizontal*

Temperature: 22 °C

Limit: FCC Class B 3M Radiation

Power:

Humidity: 60 %

EUT:

Distance: 3m

M/N: 09-0216-EP

Mode: IEEE 802.11g Link Mode

Note:

No.	Mk.	Freq. MHz	Reading Level dBuV	Correct Factor dB	Measure- ment dBuV	Limit dBuV	Over dB	Antenna Height cm	Table Degree degree	Detector	Comment
1		374.9000	45.40	-8.95	36.45	46.00	-9.55			peak	
2		500.2000	41.50	-7.17	34.33	46.00	-11.67			peak	
3	*	624.8000	43.36	-4.64	38.72	46.00	-7.28			peak	
4		664.0000	38.32	-4.43	33.89	46.00	-12.11			peak	
5		766.9000	41.43	-2.75	38.68	46.00	-7.32			peak	
6		1000.0000	41.24	0.62	41.86	54.00	-12.14			peak	

*:Maximum data x:Over limit !:over margin



File :FCC(2412MHz)

Data :#18

Date: 2009/9/4

Time: 上午 01:20:10

95.0 dBuV

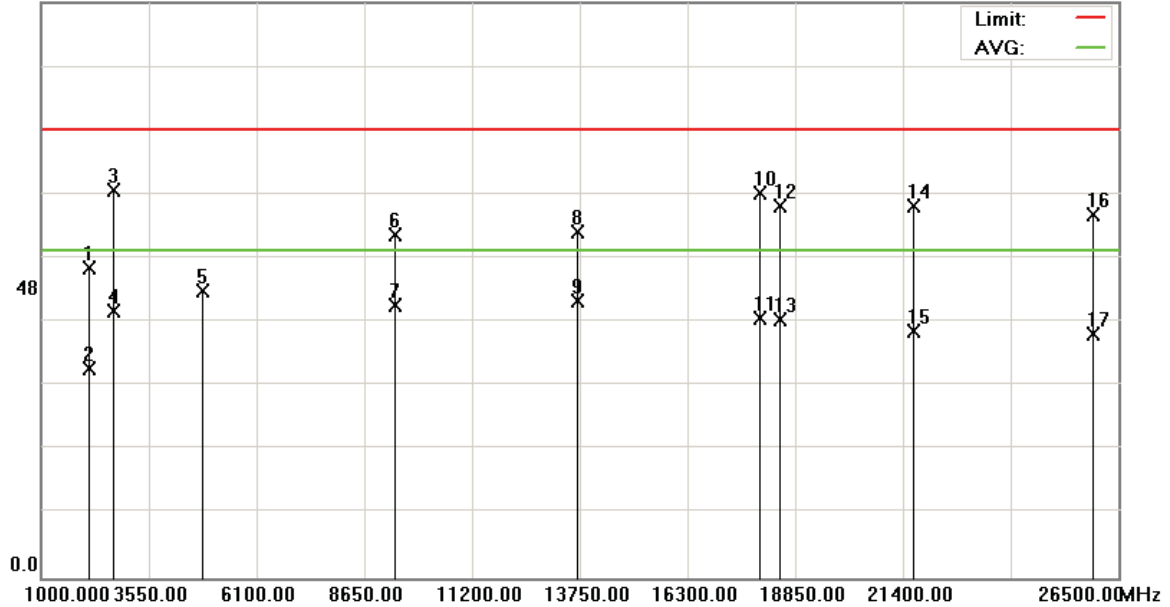

Site: site #1
 Limit: FCC part 15 (PK)
 EUT:
 M/N: 09-0216-EP
 Mode: IEEE 802.11g Link Mode
 Note: CH01(2412MHz)

Polarization: **Horizontal**
 Power:
 Distance: 3m

Temperature: 22 °C
 Humidity: 60 %

No.	Mk.	Freq. MHz	Reading Level dBuV	Correct Factor dB	Measure- ment dBuV	Limit dBuV	Over dB	Antenna Height cm	Table Degree degree	Comment
1		2139.000	51.40	-0.12	51.28	74.00	-22.72	peak		
2		2139.000	34.56	-0.12	34.44	54.00	-19.56	AVG		
3		2700.000	41.45	22.58	64.03	74.00	-9.97	peak		
4		2700.000	21.47	22.58	44.05	54.00	-9.95	AVG		
5		4824.000	39.89	7.48	47.37	74.00	-26.63	peak		
6		9343.000	39.79	16.93	56.72	74.00	-17.28	peak		
7		9343.000	28.05	16.93	44.98	54.00	-9.02	AVG		
8		13680.000	39.27	17.89	57.16	74.00	-16.84	peak		
9	*	13680.000	27.85	17.89	45.74	54.00	-8.26	AVG		
10		18000.000	38.01	25.57	63.58	74.00	-10.42	peak		
11		18000.000	17.32	25.57	42.89	54.00	-11.11	AVG		
12		18488.750	38.35	23.12	61.47	74.00	-12.53	peak		
13		18488.750	19.42	23.12	42.54	54.00	-11.46	AVG		
14		21633.750	40.23	21.28	61.51	74.00	-12.49	peak		
15		21633.750	19.42	21.28	40.70	54.00	-13.30	AVG		
16		25905.000	41.30	18.63	59.93	74.00	-14.07	peak		
17		25905.000	21.54	18.63	40.17	54.00	-13.83	AVG		

*:Maximum data x:Over limit !:over margin



File :FCC(2437MHz)

Data :#18

Date: 2009/9/4

Time: 上午 12:44:05

95.0 dBuV

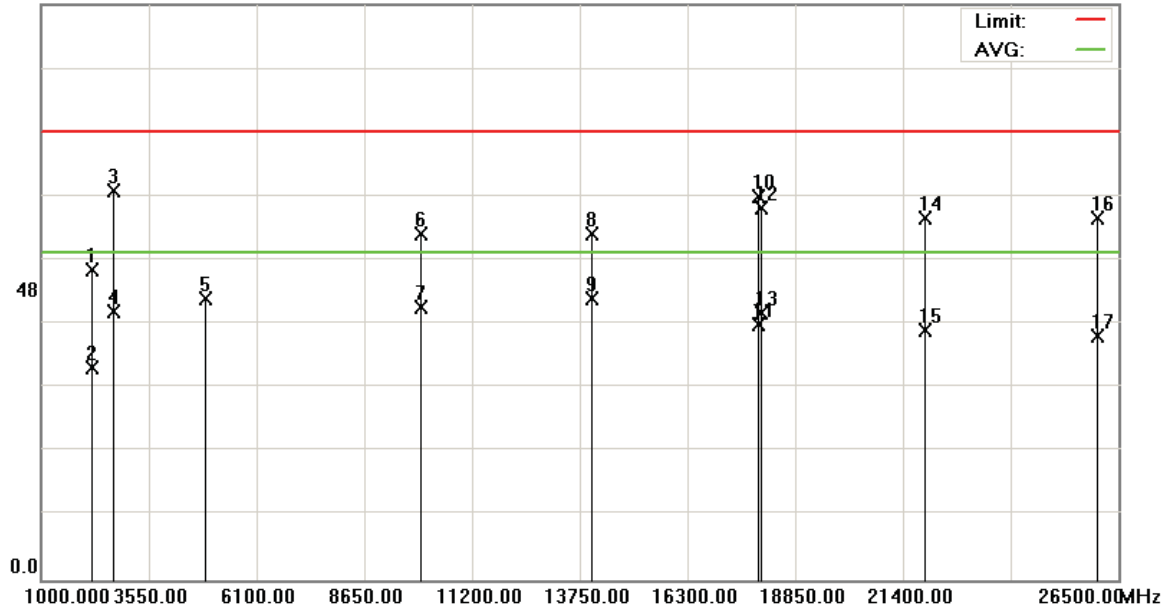

Site: site #1
 Limit: FCC part 15 (PK)
 EUT:
 M/N: 09-0216-EP
 Mode: IEEE 802.11g Link Mode
 Note: CH06(2437MHz)

Polarization: **Horizontal**
 Power:
 Distance: 3m

Temperature: 22 °C
 Humidity: 60 %

No.	Mk.	Freq. MHz	Reading Level dBuV	Correct Factor dB	Measure- ment dBuV	Limit dBuV	Over dB	Antenna Height cm	Table Degree degree	Detector	Comment
1		2188.300	50.70	0.40	51.10	74.00	-22.90			peak	
2		2188.300	34.52	0.40	34.92	54.00	-19.08			AVG	
3		2700.000	41.75	22.58	64.33	74.00	-9.67			peak	
4		2700.000	21.82	22.58	44.40	54.00	-9.60			AVG	
5		4874.000	38.65	7.72	46.37	74.00	-27.63			peak	
6		10000.000	39.12	17.94	57.06	74.00	-16.94			peak	
7		10000.000	26.97	17.94	44.91	54.00	-9.09			AVG	
8		14020.000	28.91	28.21	57.12	74.00	-16.88			peak	
9	*	14020.000	18.30	28.21	46.51	54.00	-7.49			AVG	
10		17960.000	29.01	34.38	63.39	74.00	-10.61			peak	
11		17960.000	7.80	34.38	42.18	54.00	-11.82			AVG	
12		18042.500	38.07	23.27	61.34	74.00	-12.66			peak	
13		18042.500	20.79	23.27	44.06	54.00	-9.94			AVG	
14		21910.000	38.69	21.16	59.85	74.00	-14.15			peak	
15		21910.000	20.08	21.16	41.24	54.00	-12.76			AVG	
16		26011.250	41.28	18.54	59.82	74.00	-14.18			peak	
17		26011.250	21.80	18.54	40.34	54.00	-13.66			AVG	

*:Maximum data x:Over limit !:over margin



File :FCC(2462MHz)

Data :#18

Date: 2009/9/4

Time: 上午 12:39:59

95.0 dBuV

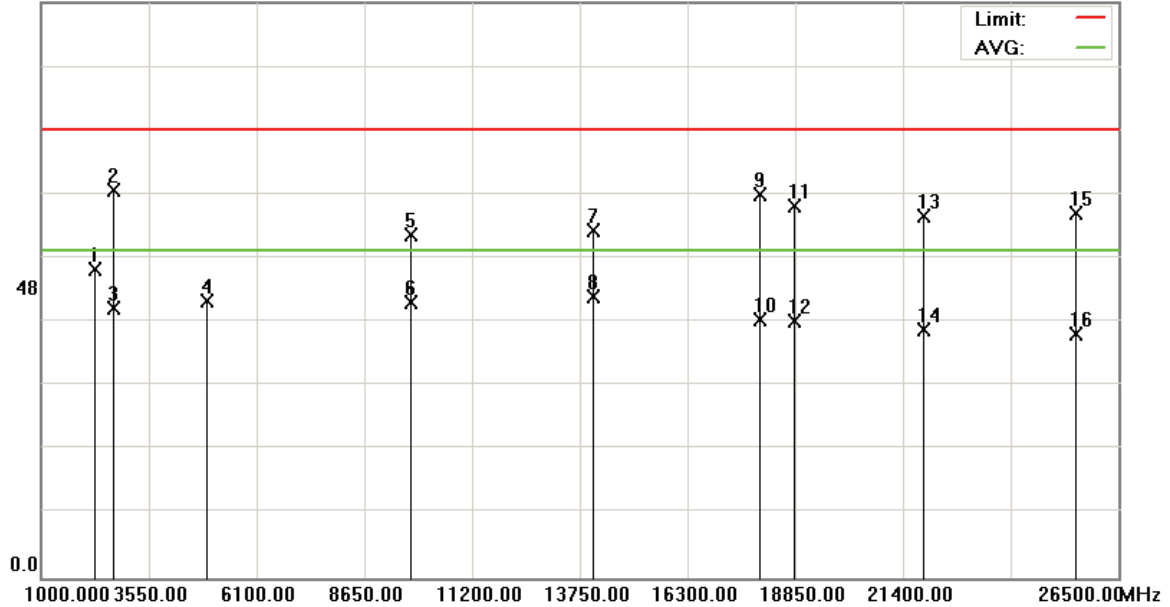

Site: site #1
 Limit: FCC part 15 (PK)
 EUT:
 M/N: 09-0216-EP
 Mode: IEEE 802.11g Link Mode
 Note: CH11(2462MHz)

Polarization: **Horizontal**
 Power:
 Distance: 3m

Temperature: 22 °C
 Humidity: 60 %

No.	Mk.	Freq. MHz	Reading Level dBuV	Correct Factor dB	Measure- ment dBuV	Limit dBuV	Over dB	Antenna Height cm	Table Degree degree	Detector	Comment
1		2261.400	50.55	0.45	51.00	74.00	-23.00			peak	
2		2700.000	41.48	22.58	64.06	74.00	-9.94			peak	
3		2700.000	21.99	22.58	44.57	54.00	-9.43			AVG	
4		4924.000	38.13	7.65	45.78	74.00	-28.22			peak	
5		9726.250	39.05	17.60	56.65	74.00	-17.35			peak	
6		9726.250	27.93	17.60	45.53	54.00	-8.47			AVG	
7		14040.000	38.79	18.66	57.45	74.00	-16.55			peak	
8	*	14040.000	27.84	18.66	46.50	54.00	-7.50			AVG	
9		18000.000	37.74	25.57	63.31	74.00	-10.69			peak	
10		18000.000	17.00	25.57	42.57	54.00	-11.43			AVG	
11		18807.500	38.26	23.16	61.42	74.00	-12.58			peak	
12		18807.500	19.24	23.16	42.40	54.00	-11.60			AVG	
13		21867.500	38.65	21.19	59.84	74.00	-14.16			peak	
14		21867.500	19.87	21.19	41.06	54.00	-12.94			AVG	
15		25501.250	41.20	18.98	60.18	74.00	-13.82			peak	
16		25501.250	21.26	18.98	40.24	54.00	-13.76			AVG	

*:Maximum data x:Over limit !:over margin



4. Maximum Conducted Output Power Requirements

4.1 Test Procedure

The tests below are run with the EUT's transmitter set at high power in TX mode. The EUT is needed to force selection of output power level and channel number. While testing, EUT was set to transmit continuously. Remove the Subjective device's antenna and connect the RF output port to spectrum analyzer. The maximum peak output power shall not exceed 1 watt.

Use a direct connection between the antenna port of transmitter and the spectrum Analyzer, for prevent the spectrum analyzer input attenuation 40-50 dB. And connect 10dB Attenuator. Set the RBW Bandwidth of the emission or use a channel power meter mode.

For antennas with gains of 6 dBi or less, maximum allowed transmitter output is 1 watt (+30 dBm). For antennas with gains greater than 6 dBi, transmitter output level must be decreased by an amount equal to $(GAIN - 6)/3$ dBm.

The antenna port of the EUT was connected to the input of a power meter. Power was read directly and cable loss correction was added to the reading to obtain power at the EUT antenna terminals.

4.2 Limits

For systems using digital modulation in the 2400 - 2483.5 MHz bands: 1 Watt.

4.3 Test Equipment List

Describe	Manufacturer	Model	Serial Number	Calibration	
				Cal. Date	Due Date
WIDE BAND SENSOR	R&S	NRP-Z81	100017	May 17, 2009	May 17, 2010
Attenuator	RADIALL	R415710000	0603033065	NA	NA

4.4 Test Instruments Configuration

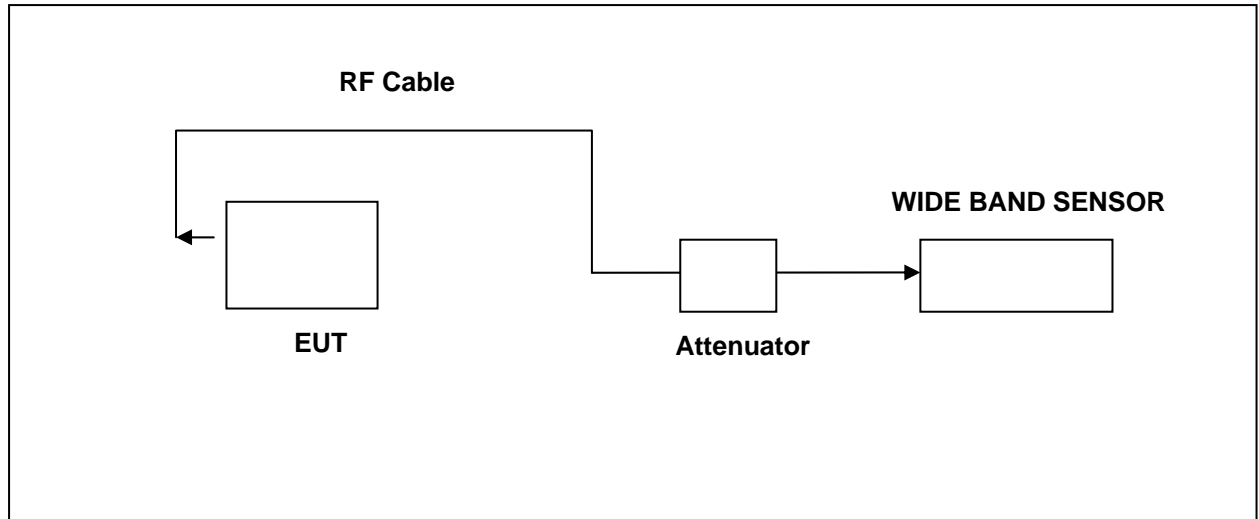

4.5 Test Result

EUT : Wireless 802.11b/g ADSL2+ Router
 Model No. : TW263R4
 Test Mode : IEEE 802.11b Link Mode
 Test Date : 09/04/2009

Frequency (MHz)	Rate	Average		Peak		Required Limit
		dBm	W	dBm	W	
2412	1	11.01	0.013	14.85	0.031	< 1W
2437	1	9.98	0.010	13.30	0.021	< 1W
2462	1	8.04	0.006	12.19	0.017	< 1W
2412	11	10.96	0.012	14.09	0.026	< 1W
2437	11	9.53	0.009	12.94	0.020	< 1W
2462	11	7.66	0.006	11.83	0.015	< 1W



EUT : Wireless 802.11b/g ADSL2+ Router

Model No. : TW263R4

Test Mode : IEEE 802.11g Link Mode

Test Date : 09/04/2009

Frequency (MHz)	Rate	Average		Peak		Required Limit
		dBm	W	dBm	W	
2412	6	10.09	0.010	18.82	0.076	< 1W
2437	6	9.20	0.008	17.95	0.062	< 1W
2462	6	7.76	0.006	17.04	0.051	< 1W
2412	54	8.12	0.006	17.04	0.051	< 1W
2437	54	7.77	0.006	16.73	0.047	< 1W
2462	54	6.05	0.004	15.95	0.039	< 1W

5. Minimum 6dB RF Bandwidth Requirements

5.1 Test Procedure

The EUT was setup to ANSI C63.4, 2003; tested to DTS test procedure of Oct 2002 KDB558074 for compliance to FCC 47CFR 15.247 requirements.

The antenna port of the EUT was connected to the input of a spectrum analyzer. Analyzer RES BW was set to 100 kHz. For each RF output channel investigated, the spectrum analyzer center frequency was set to the channel carrier. A peak output reading was taken, a DISPLAY line was drawn 6 dB lower than peak level. The 6 dB bandwidth was determined from where the channel output spectrum intersected the display line.

The test was performed at 3 channels (Channel 1, 6, 11)

5.2 Limits

Systems using digital modulation techniques may operate in the 2400–2483.5 MHz bands. The minimum 6 dB band-width shall be at least 500 kHz.

5.3 Test Equipment List

Describe	Manufacturer	Model	Serial Number	Calibration	
				Cal. Date	Due Date
Spectrum Analyzer	Agilent	E4445A	MY46181986	May 15, 2009	May 15, 2010

5.4 Test Instruments Configuration

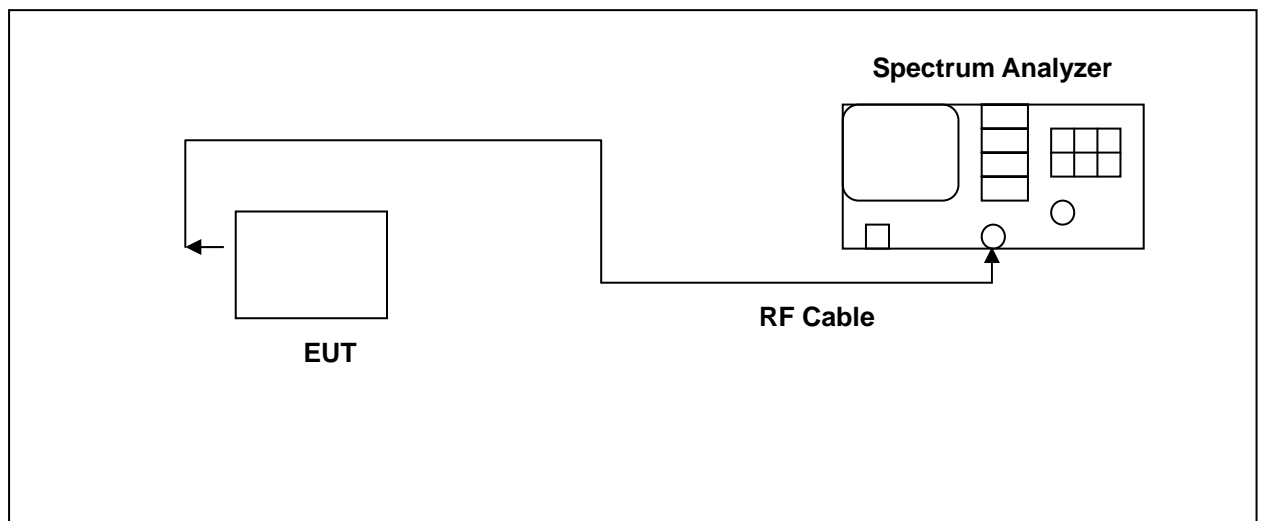



5.5 Test Result

EUT : Wireless 802.11b/g ADSL2+ Router
Model No. : TW263R4
Test Mode : IEEE 802.11b Link Mode
Test Date : 09/04/2009

Frequency (MHz)	Min. 6dB Bandwidth (MHz)	Required Limit
2412	12.375	> 500 KHz
2437	12.000	> 500 KHz
2462	12.250	> 500 KHz

EUT : Wireless 802.11b/g ADSL2+ Router
Model No. : TW263R4
Test Mode : IEEE 802.11g Link Mode
Test Date : 09/04/2009

Frequency (MHz)	Min. 6dB Bandwidth (MHz)	Required Limit
2412	16.250	> 500 KHz
2437	16.500	> 500 KHz
2462	16.500	> 500 KHz



5.6 Test Graphs

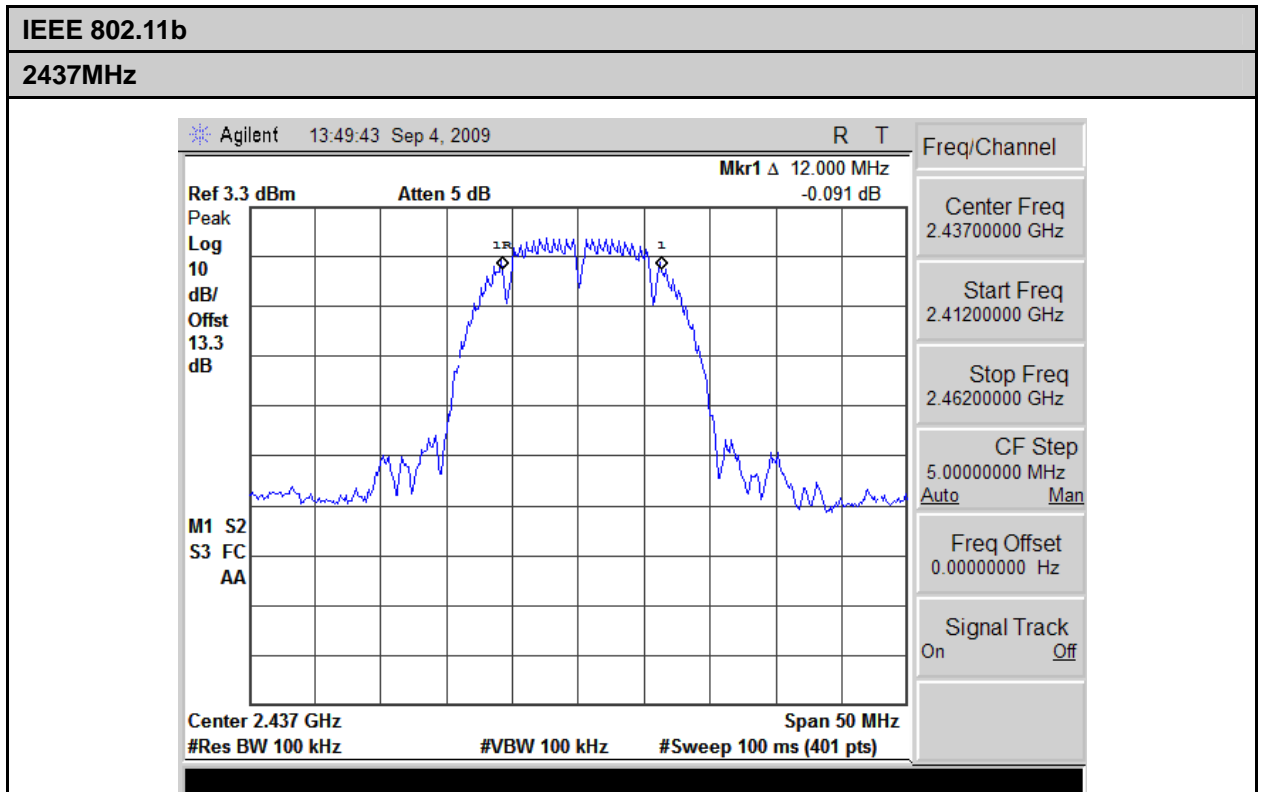
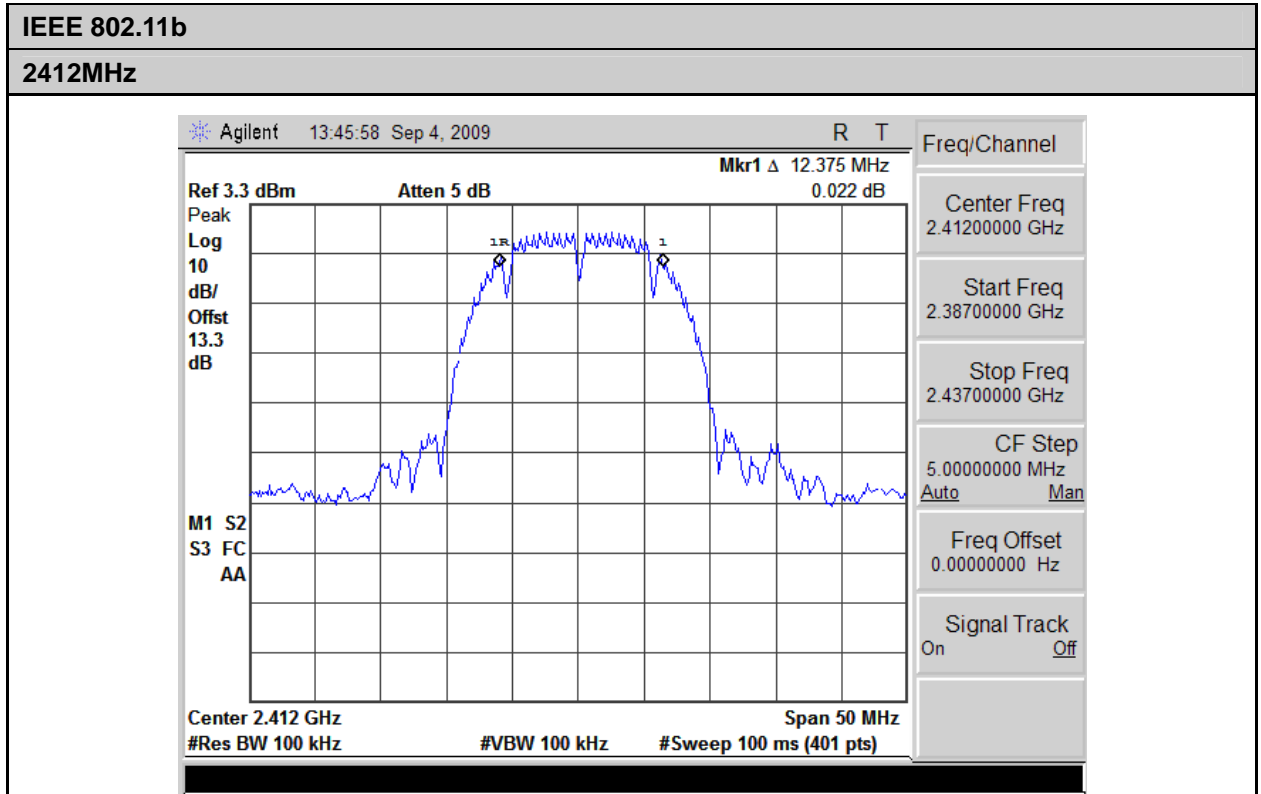



IEEE 802.11b

2462MHz

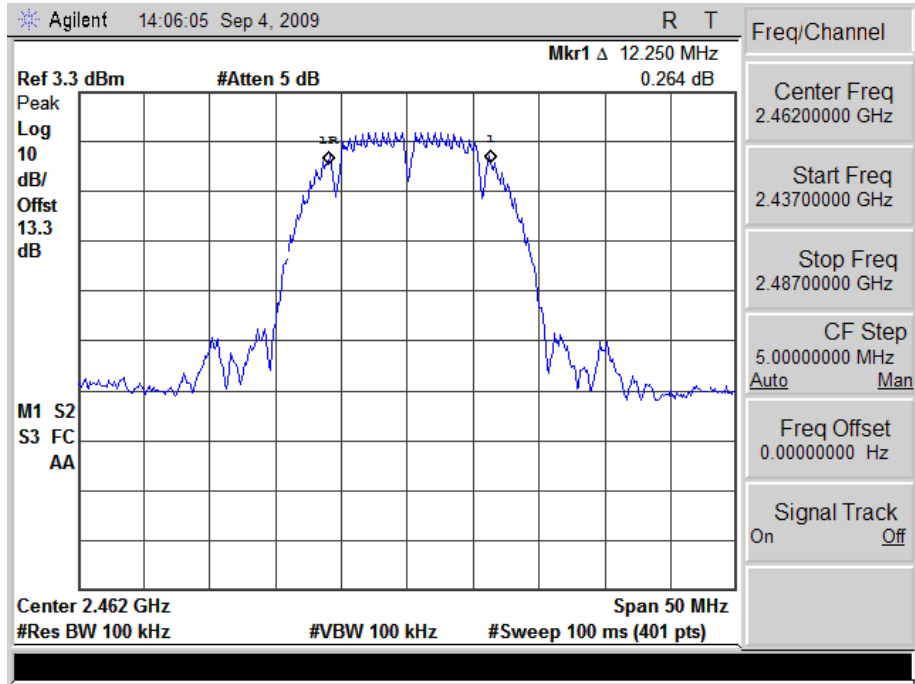



IEEE 802.11g

2412MHz

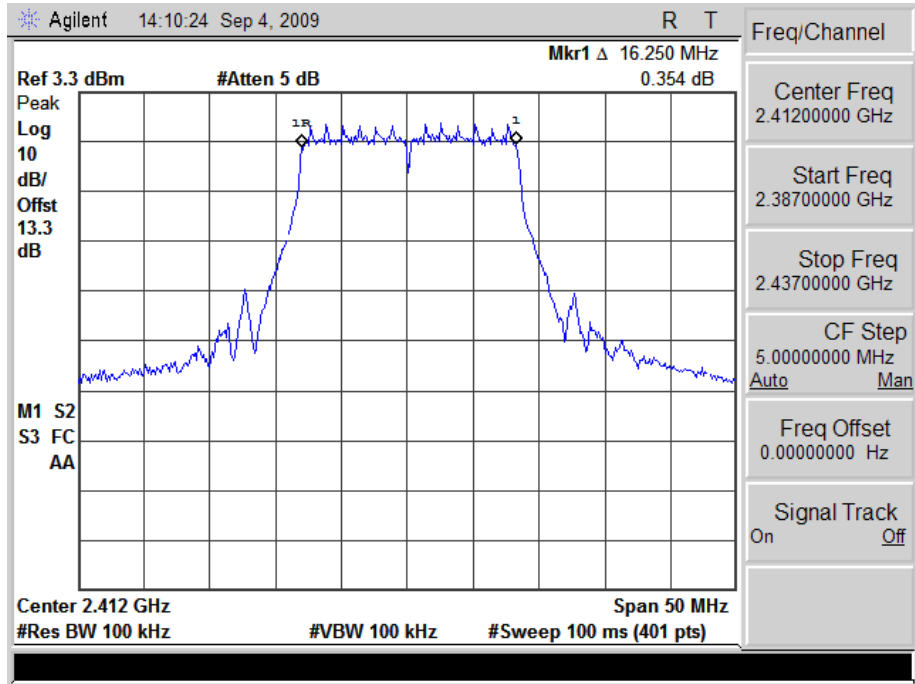

IEEE 802.11g

2437MHz

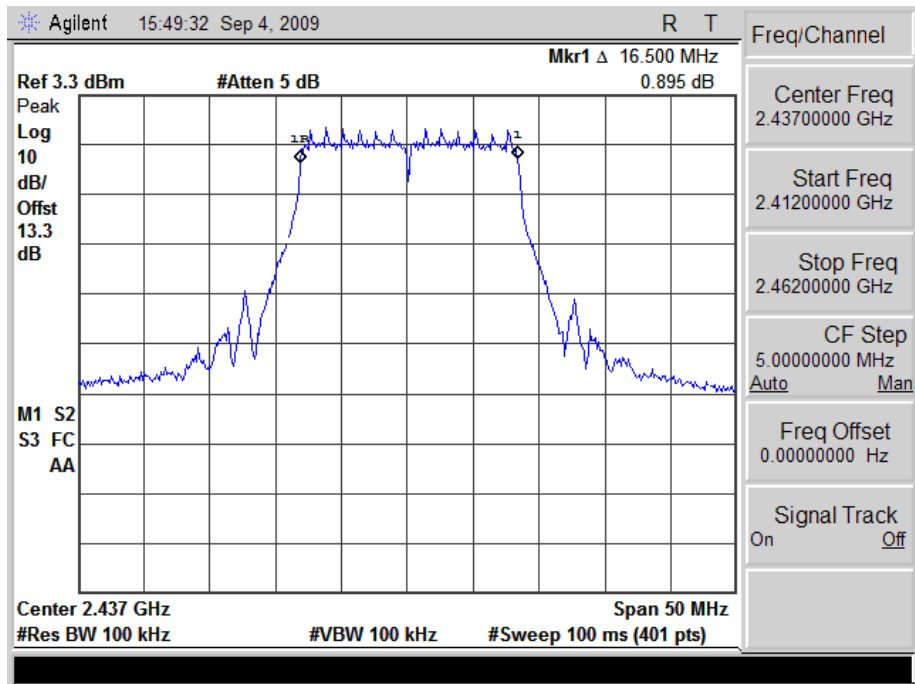



IEEE 802.11g

2462MHz

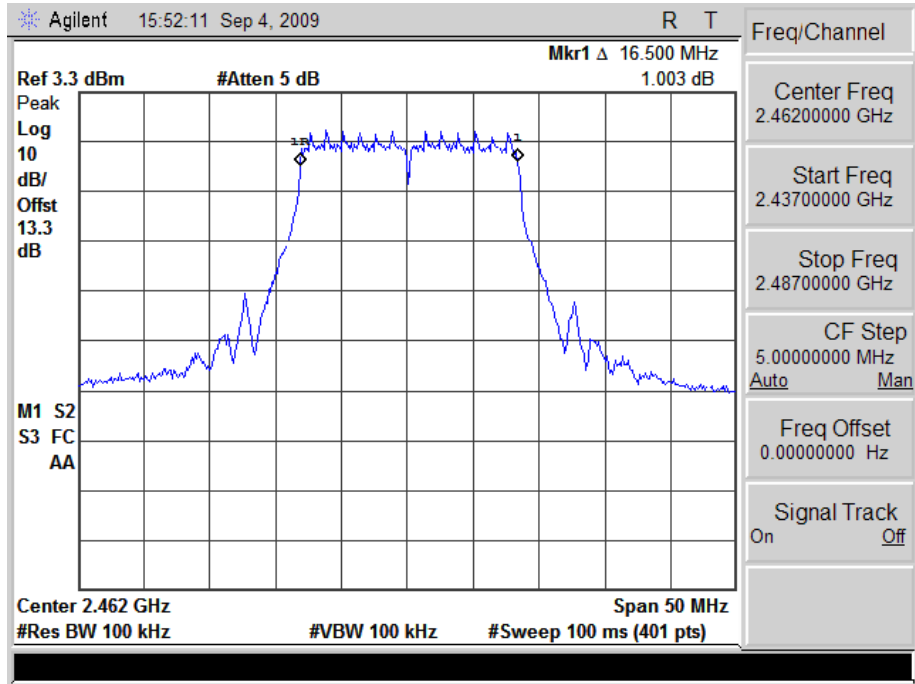



6. Maximum Power Density Requirements

6.1 Test Procedure

The EUT was setup to ANSI C63.4, 2003; tested to DTS test procedure of Oct 2002 KDB558074 for compliance to FCC 47CFR 15.247 requirements.

The spectrum analyzer RES BW was set to 3 kHz. The START and STOP frequencies were set to the band edges of the maximum output pass band. If there is no clear maximum amplitude in any given portion of the band, it may be necessary to make measurements at a number of bands defined by several START and STOP frequency pairs. The specification calls for a 1 second interval at each 3 kHz bandwidth; total SWEEP TIME is calculated as follows:

$$\text{SWEEP TIME (SEC)} = (\text{Fstop, kHz} - \text{Fstart, kHz}) / 3 \text{ kHz}$$

Antenna output of the EUT was coupled directly to spectrum analyzer; if an external attenuator and/or cable was used, these losses are compensated for with the analyzer OFFSET function.

6.2 Limits

For digitally modulated systems, the power spectral density conducted from the intentional radiator to the antenna shall not be greater than 8 dBm in any 3 kHz band during any time interval of continuous transmission.

6.3 Test Equipment List

Describe	Manufacturer	Model	Serial Number	Calibration	
				Cal. Date	Due Date
Spectrum Analyzer	Agilent	E4445A	MY46181986	May 15, 2009	May 15, 2010

6.4 Test Instruments Configuration

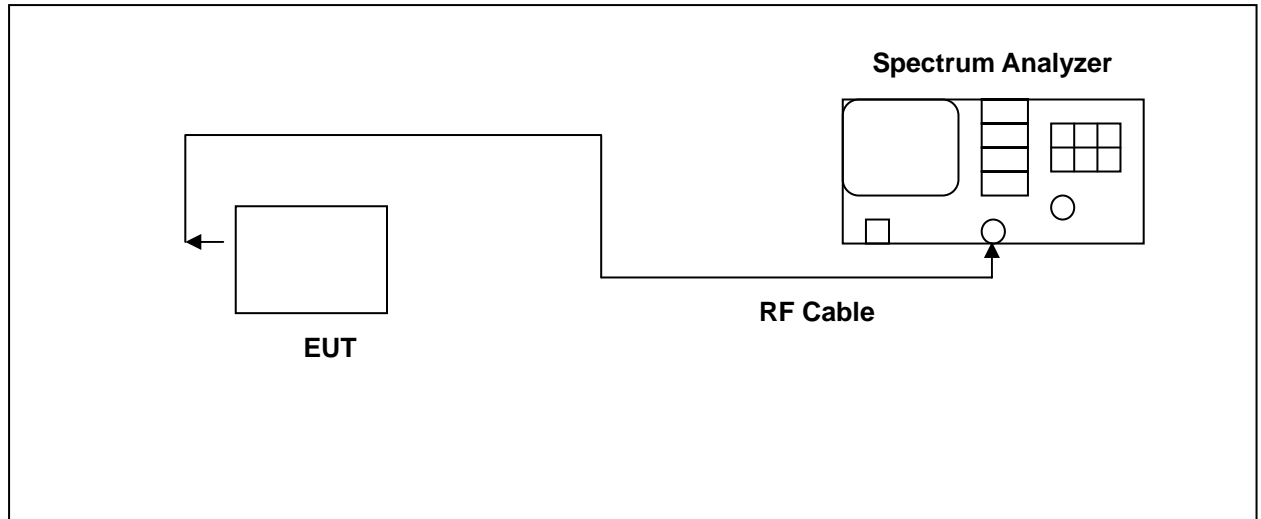

6.5 Test Result

EUT : Wireless 802.11b/g ADSL2+ Router
 Model No. : TW263R4
 Test Mode : IEEE 802.11b Link Mode
 Test Date : 09/07/2009

Frequency (MHz)	Power Density (dBm)	Required Limit
2412	-18.21	<8dBm
2437	-18.92	<8dBm
2462	-19.92	<8dBm

EUT : Wireless 802.11b/g ADSL2+ Router
 Model No. : TW263R4
 Test Mode : IEEE 802.11g Link Mode
 Test Date : 09/04/2009

Frequency (MHz)	Power Density (dBm)	Required Limit
2412	-17.05	<8dBm
2437	-17.74	<8dBm
2462	-19.16	<8dBm

Note:

1. Frequency Span= 600 kHz
2. Sweep Time = Frequency Span/3 kHz=200secs
3. Test Graphs See next page.



6.6 Test Graphs

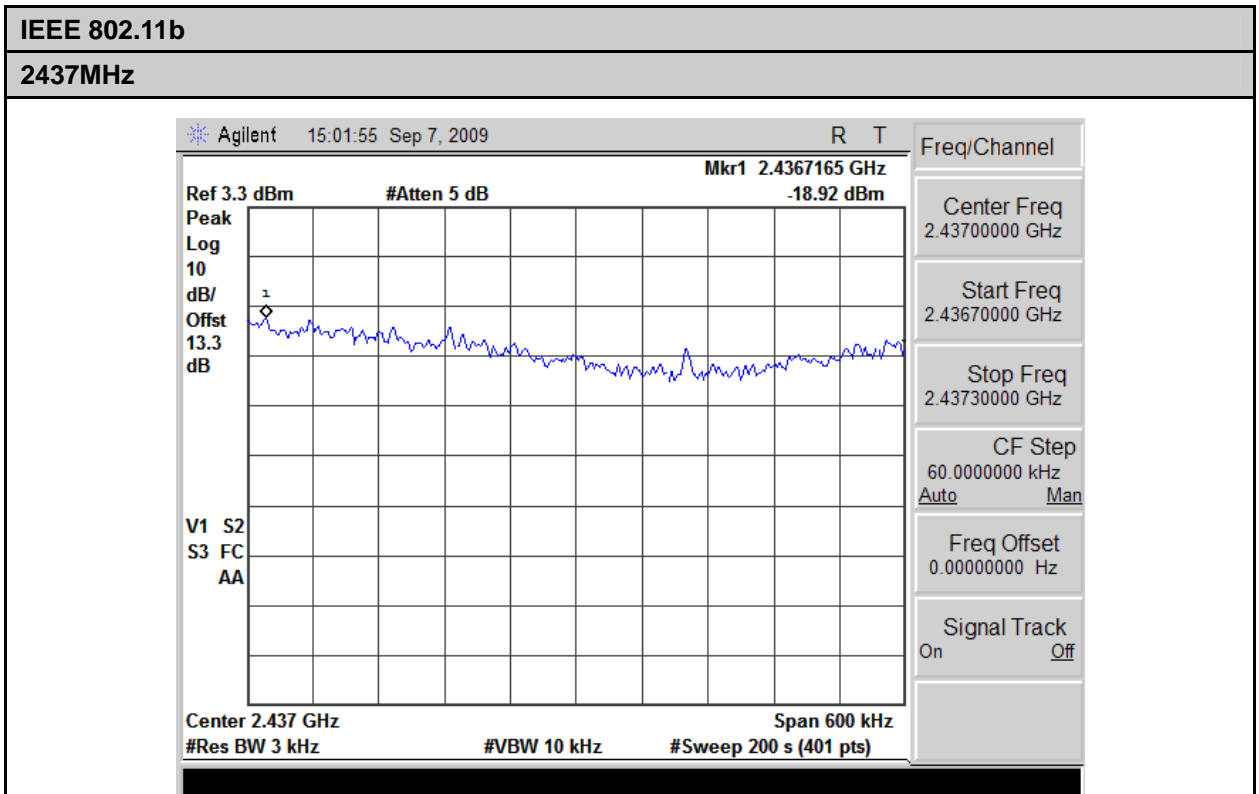
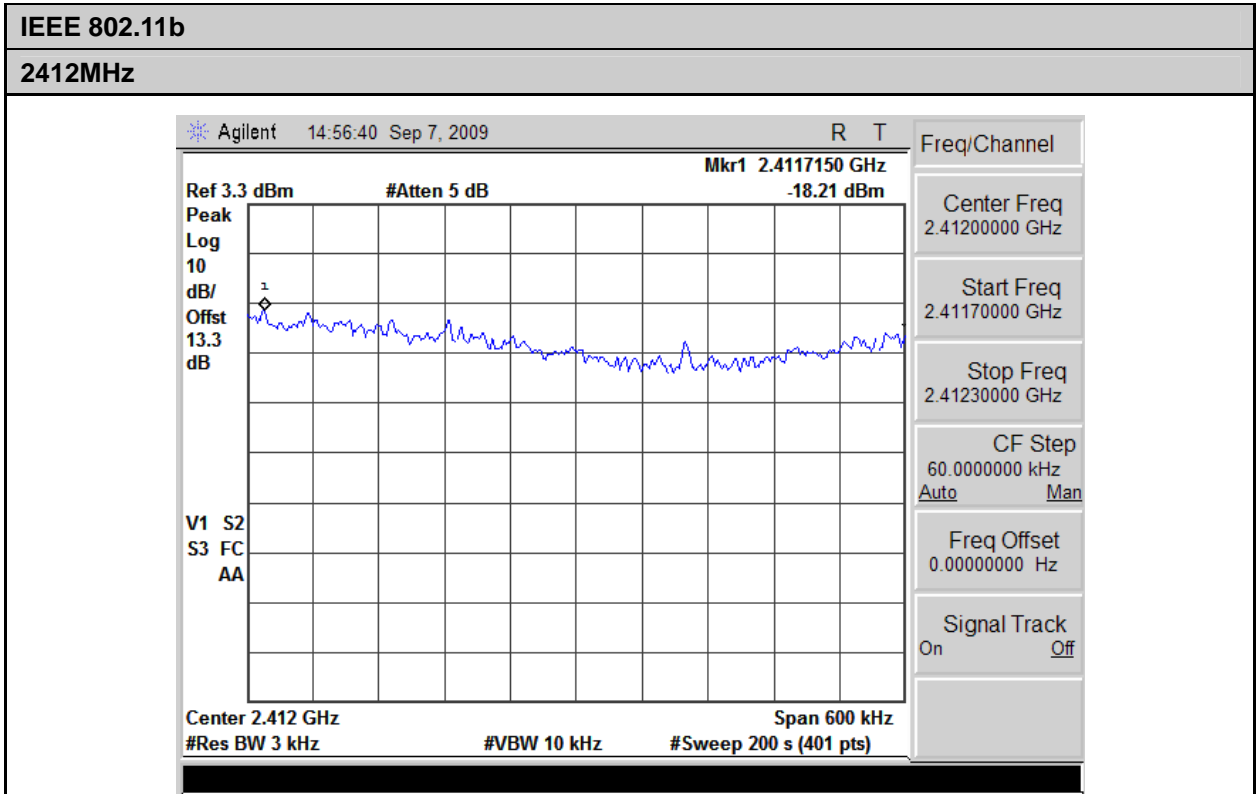



IEEE 802.11b

2462MHz

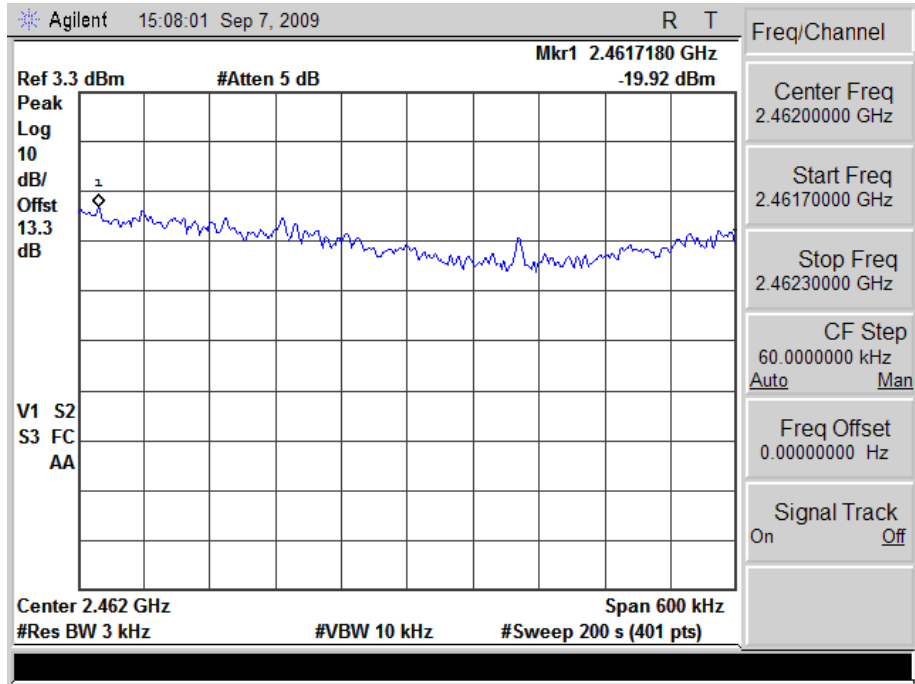

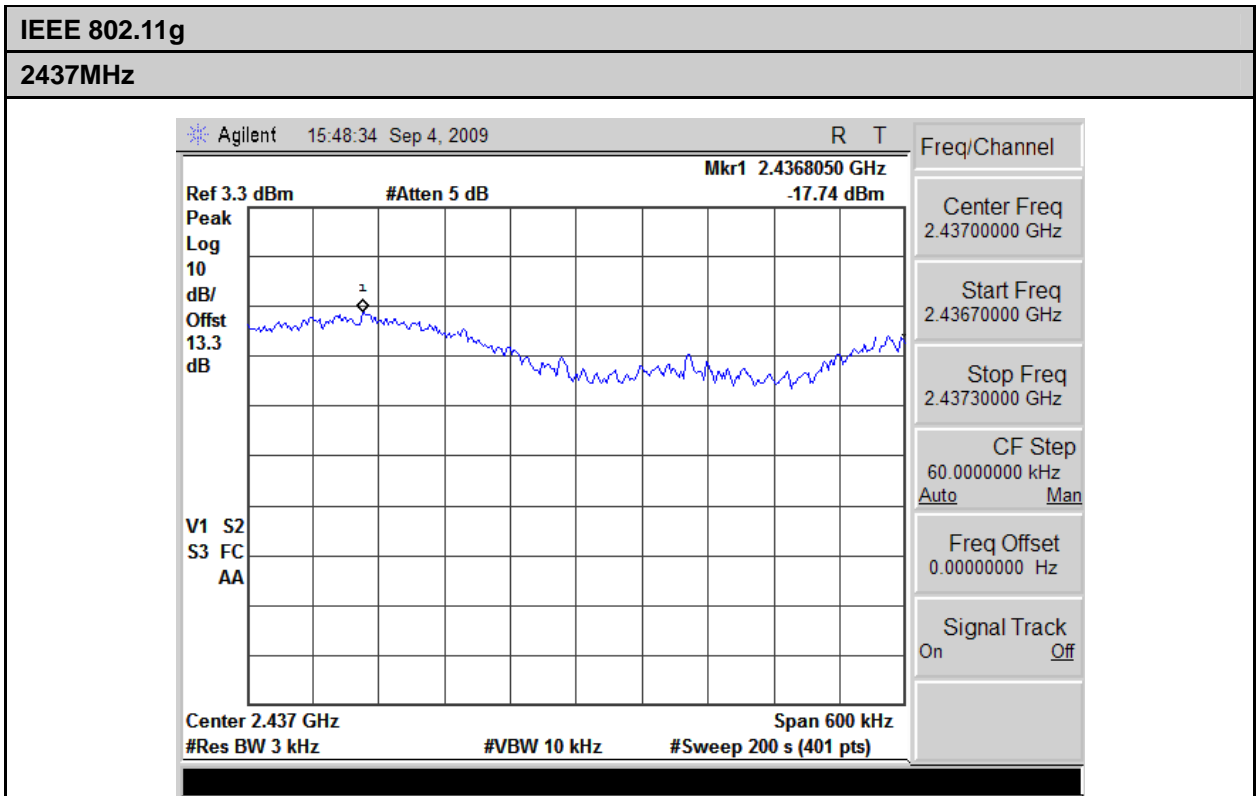
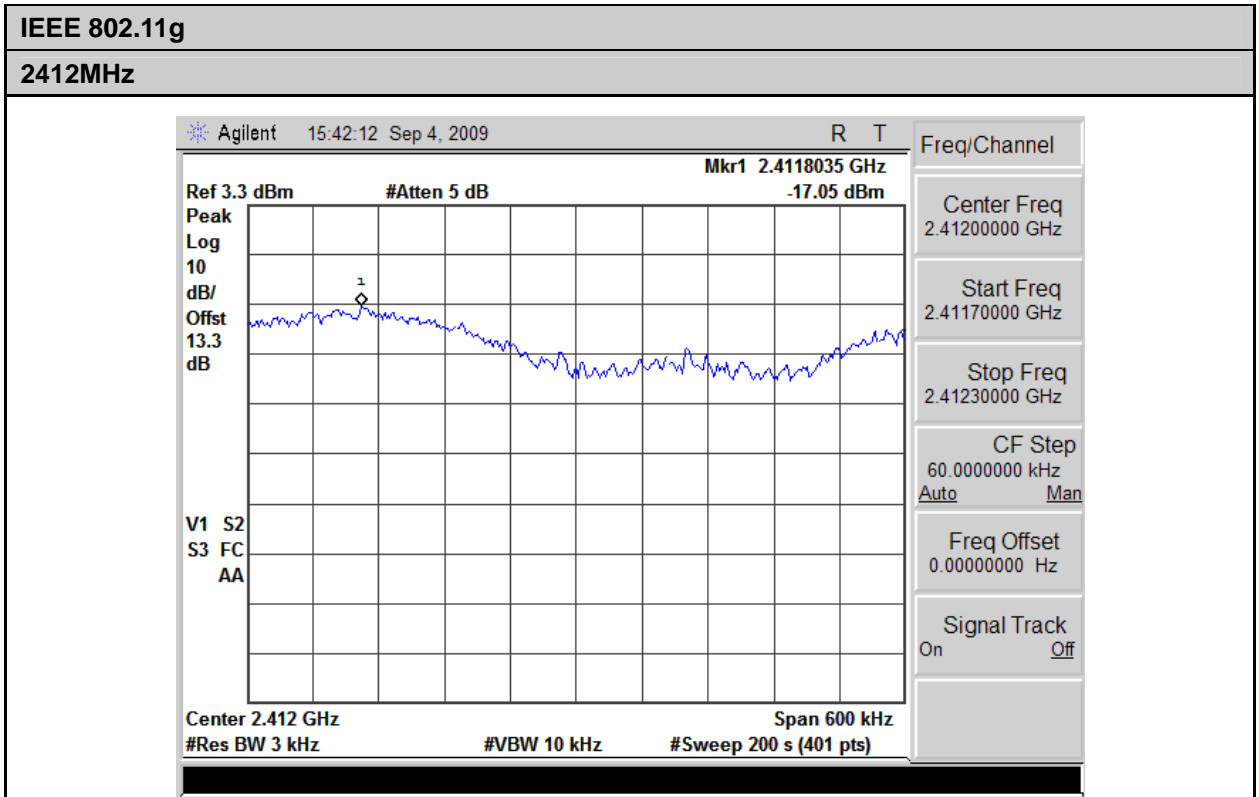



IEEE 802.11g

2462MHz

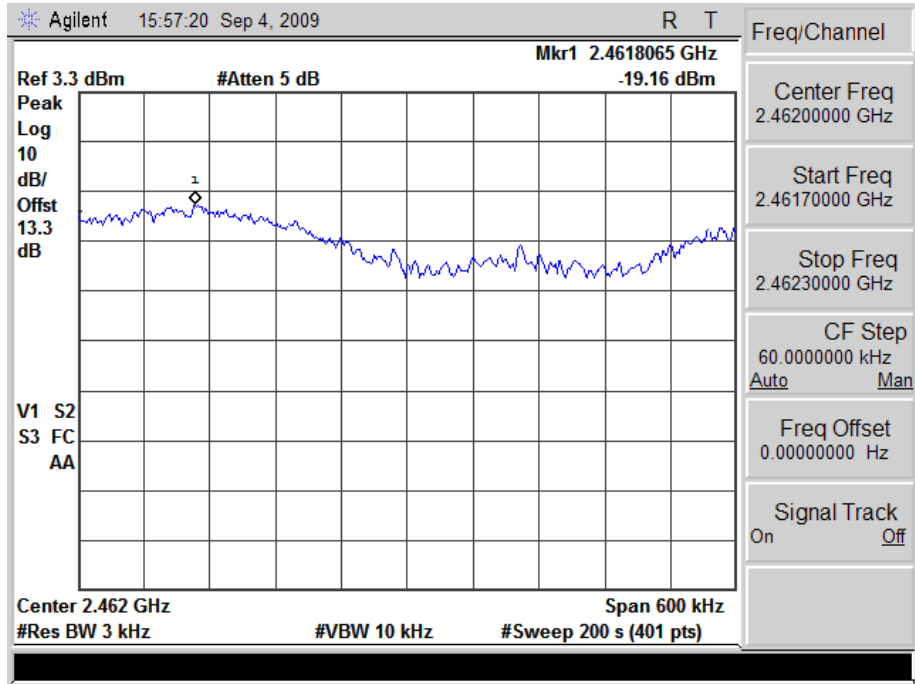

7. Out of Band Conducted Emissions Requirements

7.1 Test Procedure

The EUT was setup to ANSI C63.4, 2003; tested to DTS test procedure of Oct 2002 KDB558074 for compliance to FCC 47CFR 15.247 requirements.

In any 100 kHz bandwidth outside the EUT pass band, the RF power produced by the modulation products of the spreading sequence, the information sequence, and the carrier frequency shall be at least 20 dB below that of the maximum in-band 100 kHz emission, antenna output of the EUT was coupled directly to spectrum analyzer; if an external attenuator and/or cable was used, these losses are compensated for with the analyzer OFFSET function.

All other types of emissions from the EUT shall meet the general limits for radiated frequencies outside the pass band. The test was performed at 3 channels (Channel 1, 6, 11)

7.2 Limits

Refer to attached data sheets. Data shows out of band emissions are suppressed well below the -20 dBc minimum required by the Rules.

7.3 Test Equipment List

Describe	Manufacturer	Model	Serial Number	Calibration	
				Cal. Date	Due Date
Spectrum Analyzer	Agilent	E4445A	MY46181986	May 15, 2009	May 15, 2010

7.4 Test Instruments Configuration

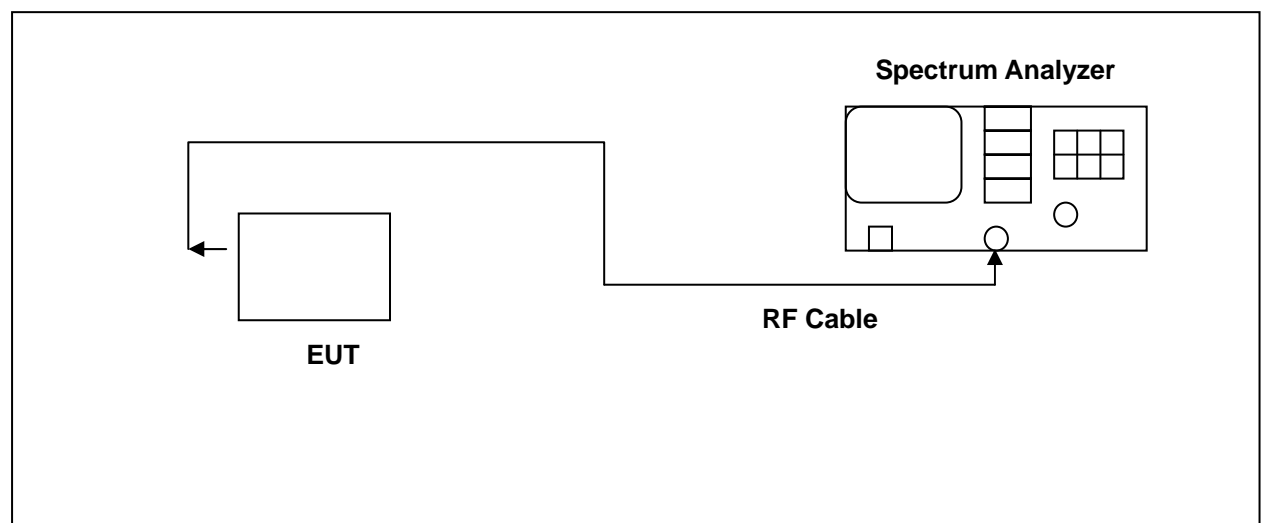



7.5 Test Result

EUT : Wireless 802.11b/g ADSL2+ Router

Model No. : TW263R4

Test Mode : IEEE 802.11b Link Mode

Test Date : 09/04/2009

Please refer to next page of detail testing data.



File :20dB(11b)

Data :#1

Date: 2009/9/4

Time: 下午 04:21:32

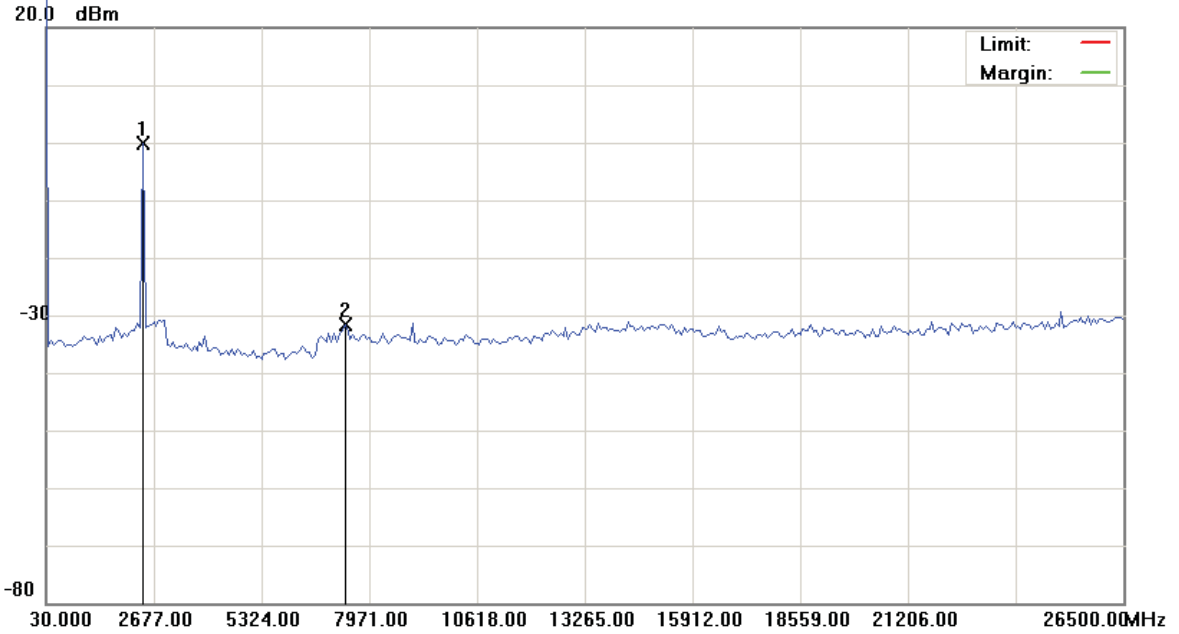

Site: site #1	Polarization:	Temperature: 26 °C
Limit:	Power: AC 110V/60Hz	Humidity: 55 %
EUT:	Distance:	
M/N: 09-0216-EP		
Mode: IEEE 802.11b Link Mode		
Note: 2412		

No.	Mk.	Freq. MHz	Reading Level dBm	Correct Factor dB	Measure- ment dBm	Limit dBm	Over dB	Antenna Height cm	Table Degree degree	Comment
1	*	2412.300	-1.21	1.00	-0.21			peak		TX
2		7375.425	-32.70	1.00	-31.70			peak		

*:Maximum data x:Over limit !:over margin



File :20dB(11b)

Data :#2

Date: 2009/9/4

Time: 下午 04:23:29

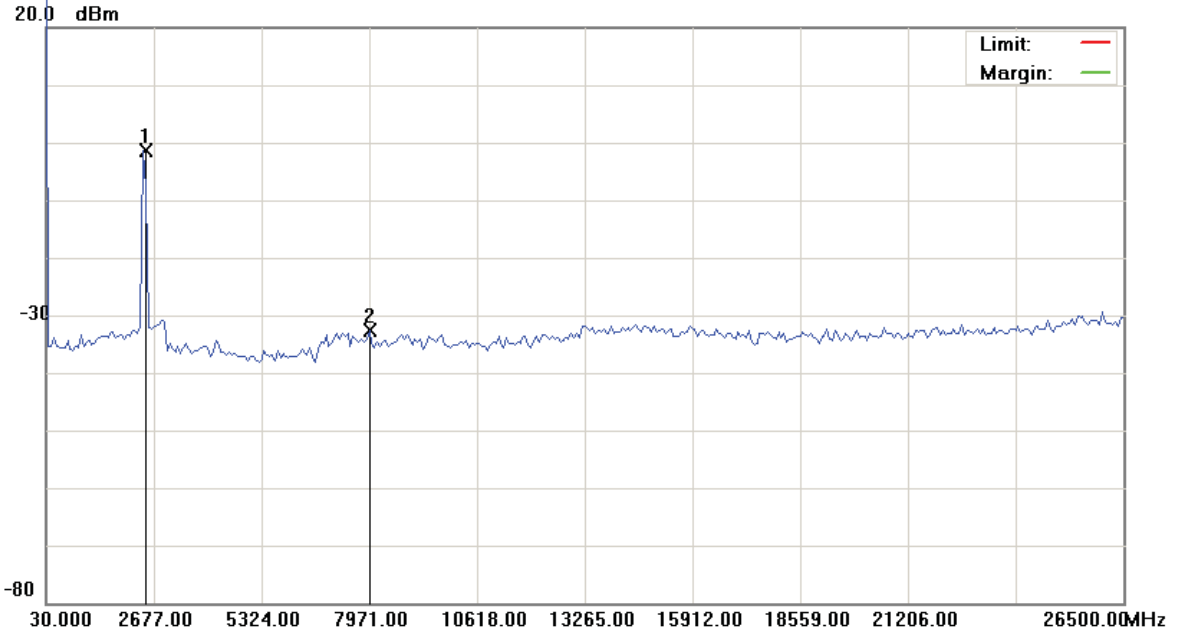

Site: site #1	Polarization:	Temperature: 26 °C
Limit:	Power: AC 110V/60Hz	Humidity: 55 %
EUT:	Distance:	
M/N: 09-0216-EP		
Mode: IEEE 802.11b Link Mode		
Note: 2437		

No.	Mk.	Freq. MHz	Reading Level dBm	Correct Factor dB	Measure- ment dBm	Limit dBm	Over dB	Antenna Height cm	Table Degree degree	Comment
1	*	2437.000	-2.42	1.00	-1.42			peak		TX
2		7971.000	-33.52	1.00	-32.52			peak		

*:Maximum data x:Over limit !:over margin



File :20dB(11b)

Data :#3

Date: 2009/9/4

Time: 下午 04:23:48

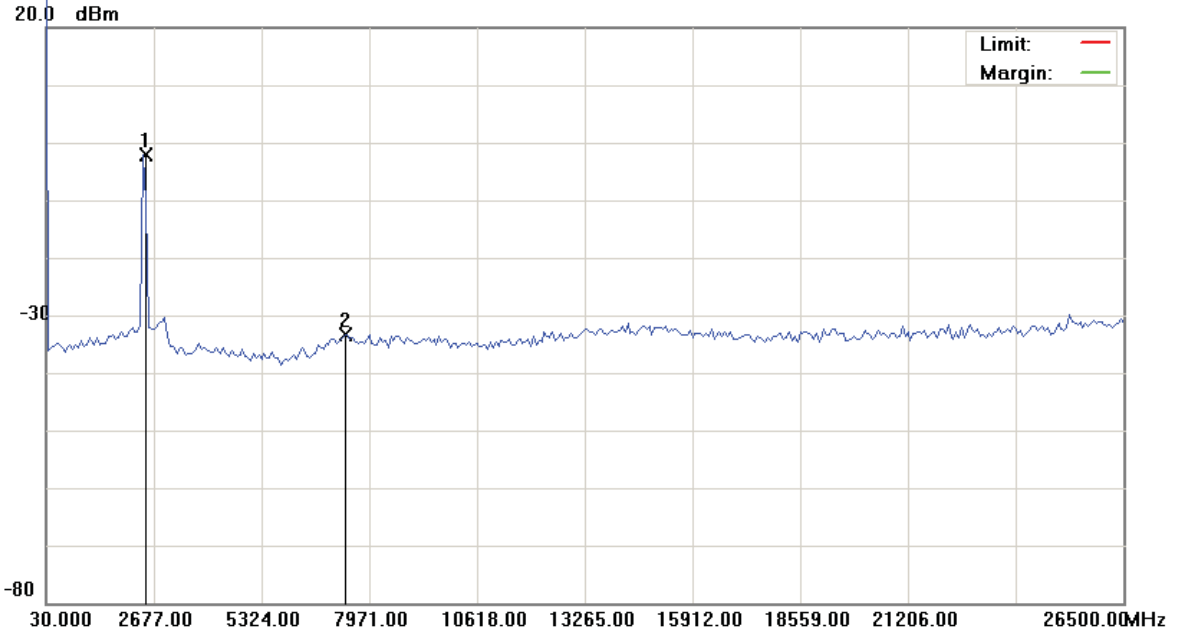

Site: site #1
 Limit:
 EUT:
 M/N: 09-0216-EP
 Mode: IEEE 802.11b Link Mode
 Note: 2462

Polarization:
 Power: AC 110V/60Hz
 Distance:

Temperature: 26 °C
 Humidity: 55 %

No.	Mk.	Freq. MHz	Reading Level dBm	Correct Factor dB	Measure- ment dBm	Limit dBm	Over dB	Antenna Height cm	Table Degree degree	Comment
1	*	2462.000	-3.03	1.00	-2.03			peak		TX
2		7375.425	-34.27	1.00	-33.27			peak		

*:Maximum data x:Over limit !:over margin



EUT : Wireless 802.11b/g ADSL2+ Router

Model No. : TW263R4

Test Mode : IEEE 802.11g Link Mode

Test Date : 09/04/2009

Please refer to next page of detail testing data.



File :20dB(11g)

Data :#1

Date: 2009/9/4

Time: 下午 04:16:53

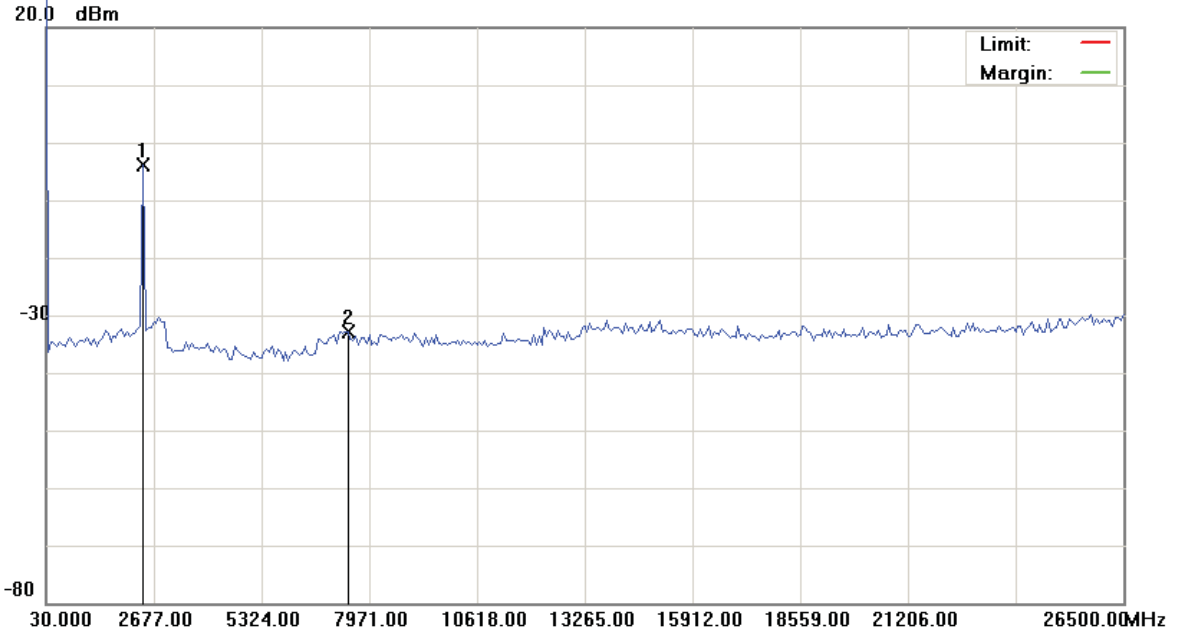

Site: site #1	Polarization:	Temperature: 26 °C
Limit:	Power: AC 110V/60Hz	Humidity: 55 %
EUT:	Distance:	
M/N: 09-0216-EP		
Mode: IEEE 802.11g Link Mode		
Note: 2412		

No.	Mk.	Freq. MHz	Reading Level dBm	Correct Factor dB	Measure- ment dBm	Limit dBm	Over dB	Detector	Antenna Height cm	Table Degree degree	Comment
1	*	2412.300	-4.76	1.00	-3.76			peak			TX
2		7441.600	-33.84	1.00	-32.84			peak			

*:Maximum data x:Over limit !:over margin



File :20dB(11g)

Data :#2

Date: 2009/9/4

Time: 下午 04:18:40

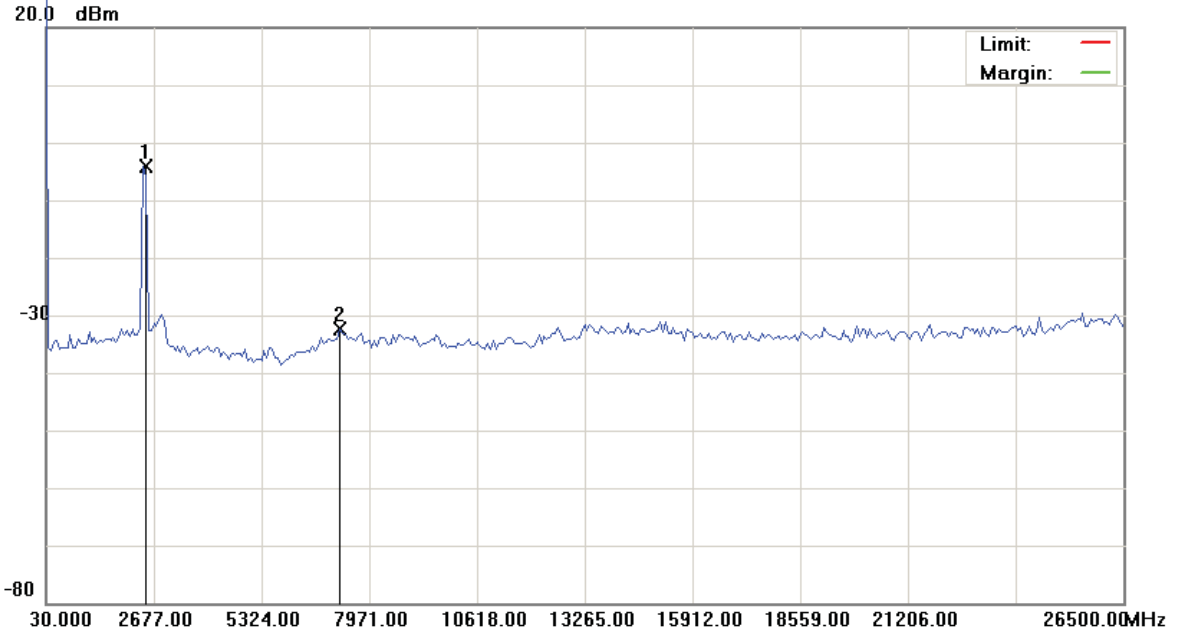

Site: site #1	Polarization:	Temperature: 26 °C
Limit:	Power: AC 110V/60Hz	Humidity: 55 %
EUT:	Distance:	
M/N: 09-0216-EP		
Mode: IEEE 802.11g Link Mode		
Note: 2437		

No.	Mk.	Freq. MHz	Reading Level dBm	Correct Factor dB	Measure- ment dBm	Limit dBm	Over dB	Antenna Height cm	Table Degree degree	Comment
1	*	2437.000	-5.15	1.00	-4.15			peak		TX
2		7243.075	-33.40	1.00	-32.40			peak		

*:Maximum data x:Over limit !:over margin



File :20dB(11g)

Data :#3

Date: 2009/9/4

Time: 下午 04:13:10

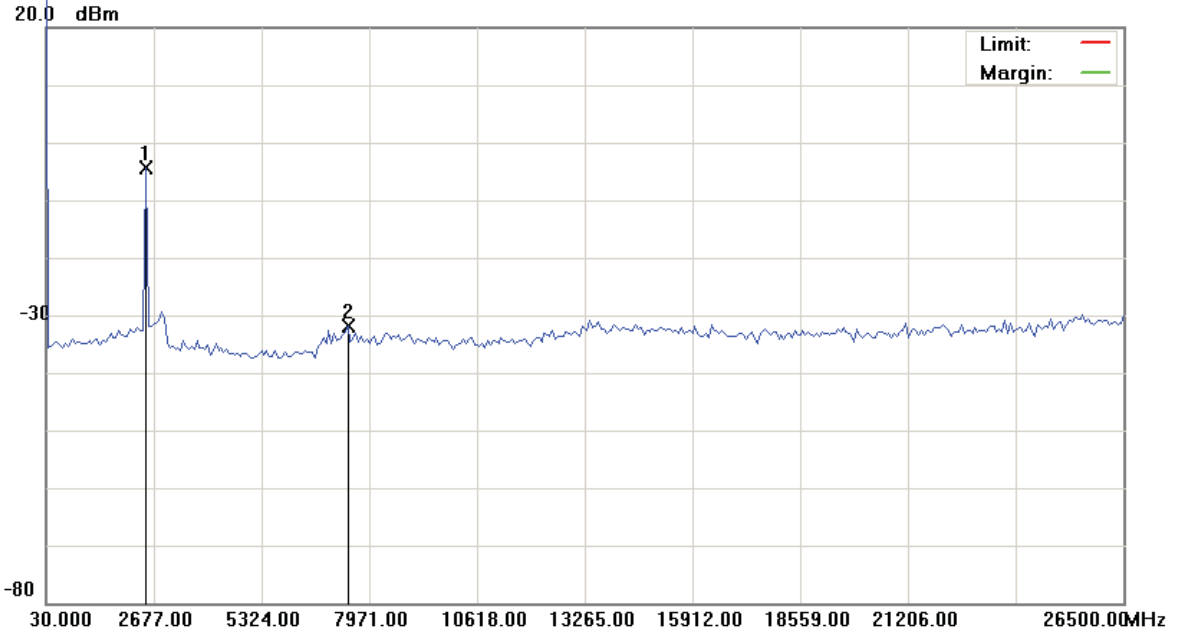

Site: site #1	Polarization:	Temperature: 26 °C
Limit:	Power: AC 110V/60Hz	Humidity: 55 %
EUT:	Distance:	
M/N: 09-0216-EP		
Mode: IEEE 802.11g Link Mode		
Note: 2462		

No.	Mk.	Freq. MHz	Reading Level dBm	Correct Factor dB	Measure- ment dBm	Limit dBm	Over dB	Antenna Height cm	Table Degree degree	Comment
1	*	2462.000	-5.39	1.00	-4.39			peak		TX
2		7441.600	-32.94	1.00	-31.94			peak		

*:Maximum data x:Over limit !:over margin



8. Band Edges Requirements

8.1 Test Procedure

The EUT was setup to ANSI C63.4, 2003; tested to DTS test procedure of Oct 2002 KDB558074 for compliance to FCC 47CFR 15.247 requirements.

The emissions on the harmonics frequencies, the limits, and the margin of compliance are presented. These tests were made when the transmitter was in full radiated power. The additional test was performed to show compliance with the requirement at the band-edge frequency 2483.5 MHz and up to 2500 MHz and at 2390.0 MHz.

The transmitter was configured with the worst case antenna and setup to transmit at the highest channel. Then the field strength was measured at 2483.5 MHz.

The transmitter was then configured with the worst case antenna and setup to transmit at the lowest channel. Then the field strength was measured at 2390.0 MHz. These tests were performed at 4 different bit rates.

8.2 Limits

In any 100 kHz bandwidth outside the intentional radiation frequency band, the radio frequency power shall be at least 20 dB below the highest level of the radiated power. In addition, radiated emissions which fall in the restricted bands must also comply with the radiated emission limits.

8.3 Test Equipment List

Describe	Manufacturer	Model	Serial Number	Calibration	
				Cal. Date	Due Date
Spectrum Analyzer	Agilent	E4408B	MY45107753	Jun. 08, 2009	Jun. 08, 2010
Pre Amplifier	Agilent	8449B	3008A02237	Jun. 08, 2009	Jun. 08, 2010
Horn Antenna	SCHWARZBECK MESS-ELEKTRONIK	BBHA9120D	9120D-550	Jul. 01, 2009	Jul. 01, 2010

8.4 Test Instruments Configuration

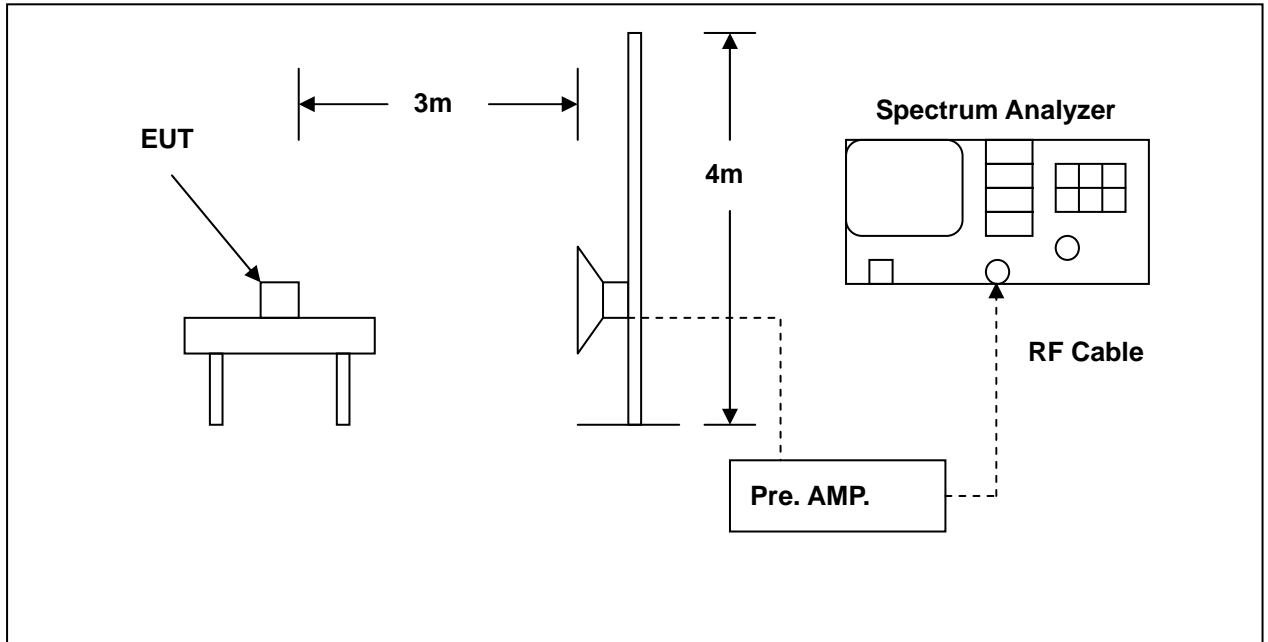

8.5 Test Result

EUT : Wireless 802.11b/g ADSL2+ Router
 Model No. : TW263R4
 Test Mode : IEEE 802.11b Link Mode Low CH & High CH
 Test Date : 09/07/2009

Please refer to next page of detail testing data.

Notes:

1. Margin= Amplitude - Limits
2. Height of table for EUT placed: 0.8 Meter.
3. ANT= Antenna height.
4. Duty= Duty cycle correction factor.
5. Dis= Distance extrapolation factor.
6. Amplitude= Reading Amplitude – Amplifier gain + Cable loss + Antenna factor
 (Auto calculate in spectrum analyzer)
7. Actual Amp= Amplitude – Duty – Dis.



File :FCC(BAND EDGE) power 5
125.0 dBuV

Data :#1

Date:2009/9/7

Time: 下午 12:09:41

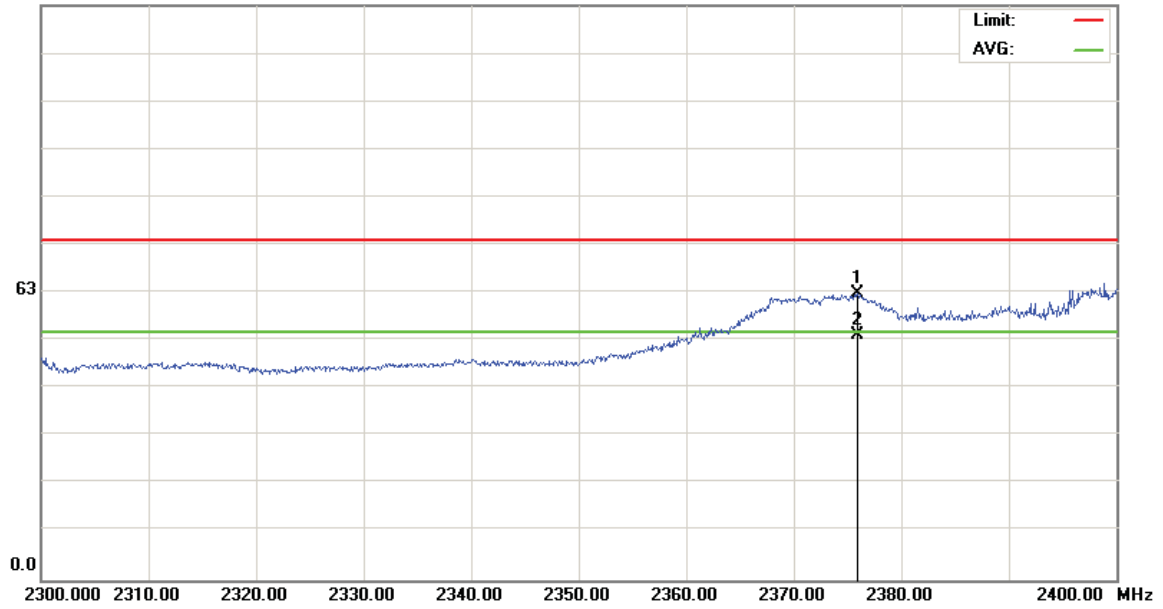

Site Polarization: *Vertical* Temperature: 22 °C
 Limit: FCC part 15 (PK) Power: Humidity: 60 %
 EUT: Distance: 3m
 M/N: 09-0216-EP
 Mode: BAND EDGE(11b)
 Note: CH01(2412MHz)

No.	Mk.	Freq.	Reading Level	Correct Factor	Measurement	Limit	Over	Antenna Height	Table Degree	
		MHz	dBuV	dB	dBuV	dBuV	dB	cm	degree	Comment
1		2375.900	62.04	0.16	62.20	74.00	-11.80			peak
2	*	2375.900	53.00	0.16	53.16	54.00	-0.84			AVG

*:Maximum data x:Over limit !:over margin

●Reference Only



File :FCC(BAND EDGE) power 5
125.0 dBuV

Data :#5

Date:2009/9/7

Time: 下午 12:13:16

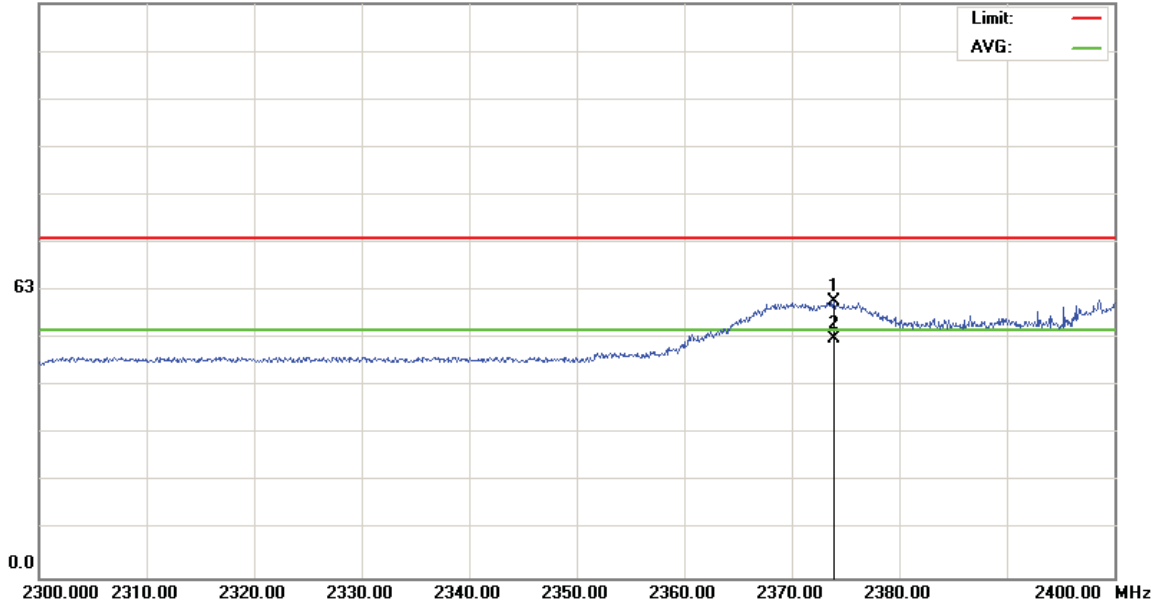

Site Polarization: *Horizontal* Temperature: 22 °C
 Limit: FCC part 15 (PK) Power: Humidity: 60 %
 EUT: Distance: 3m
 M/N: 09-0216-EP
 Mode: BAND EDGE(11b)
 Note: CH01(2412MHz)

No.	Mk.	Freq.	Reading Level	Correct Factor	Measurement	Limit	Over	Antenna Height	Table Degree	
		MHz	dBuV	dB	dBuV	dBuV	dB	cm	degree	Comment
1		2373.900	59.95	0.17	60.12	74.00	-13.88			peak
2	*	2373.900	51.95	0.17	52.12	54.00	-1.88			AVG

*:Maximum data x:Over limit !:over margin

●Reference Only



File :FCC(BAND EDGE) power 5
125.0 dBuV

Data :#3

Date:2009/9/7

Time: 下午 12:23:15

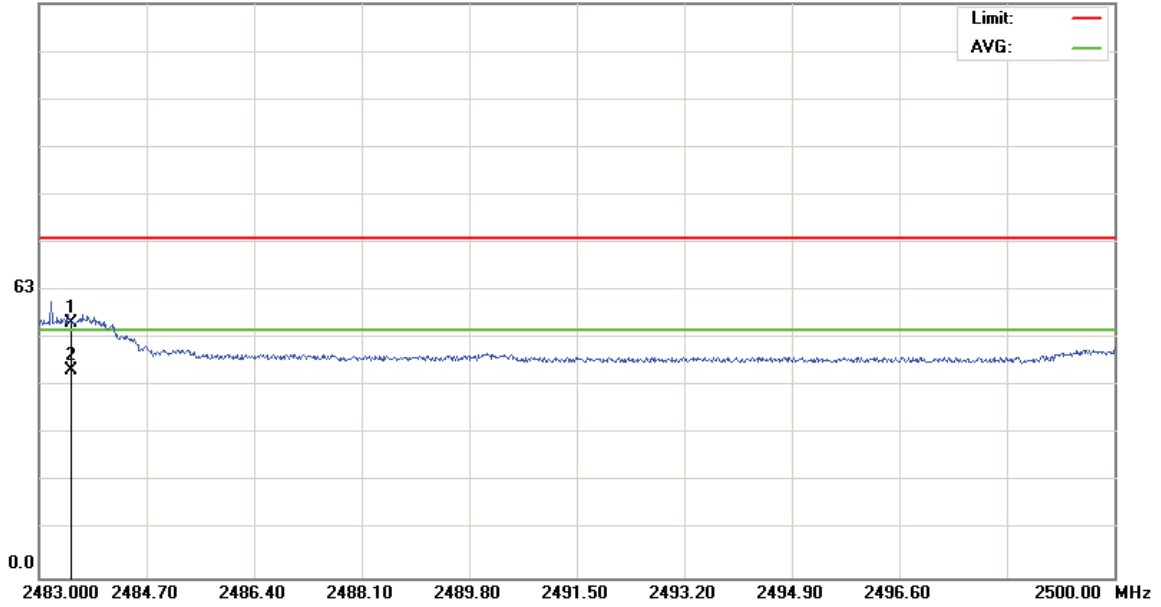

Site Polarization: *Vertical* Temperature: 22 °C
 Limit: FCC part 15 (PK) Power: Humidity: 60 %
 EUT: Distance: 3m
 M/N: 09-0216-EP
 Mode: BAND EDGE(11b)
 Note: CH11(2462MHz)

No.	Mk.	Freq.	Reading Level	Correct Factor	Measurement	Limit	Over	Antenna Height	Table Degree	
		MHz	dBuV	dB	dBuV	dBuV	dB	cm	degree	Comment
1		2483.500	55.07	0.25	55.32	74.00	-18.68			peak
2	*	2483.500	44.86	0.25	45.11	54.00	-8.89			AVG

*:Maximum data x:Over limit !:over margin

●Reference Only



File :FCC(BAND EDGE) power 5
125.0 dBuV

Data :#7

Date:2009/9/7

Time: 下午 12:19:53

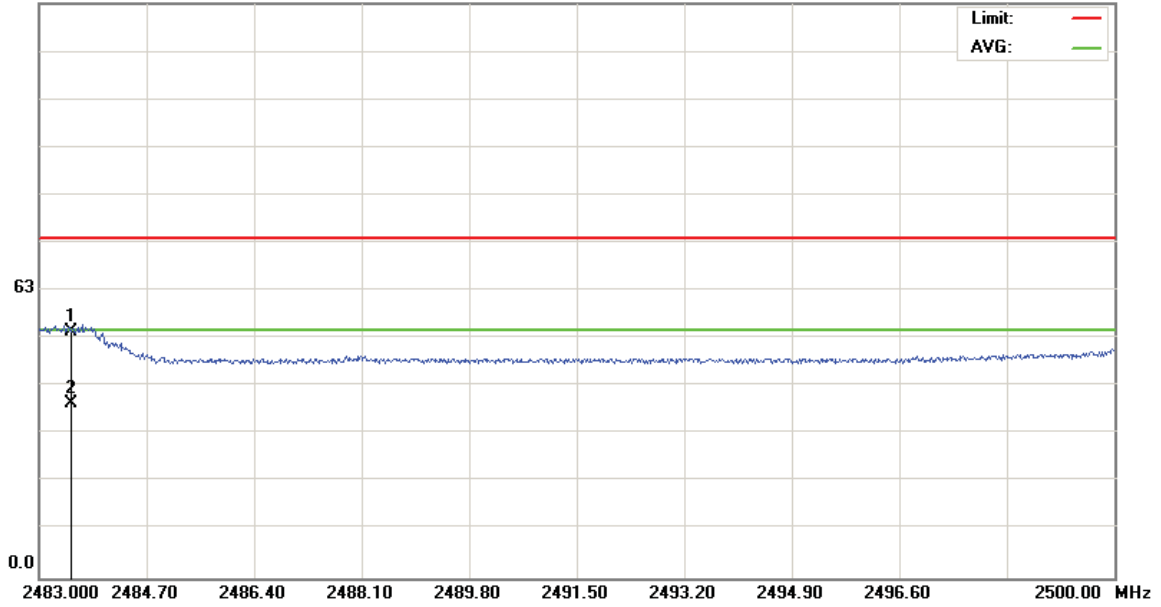

Site Polarization: *Horizontal* Temperature: 22 °C
 Limit: FCC part 15 (PK) Power: Humidity: 60 %
 EUT: Distance: 3m
 M/N: 09-0216-EP
 Mode: BAND EDGE(11b)
 Note: CH11(2462MHz)

No.	Mk.	Freq.	Reading Level	Correct Factor	Measurement	Limit	Over	Antenna Height	Table Degree	
		MHz	dBuV	dB	dBuV	dBuV	dB	cm	degree	Comment
1		2483.500	53.37	0.25	53.62	74.00	-20.38			peak
2	*	2483.500	37.58	0.25	37.83	54.00	-16.17			AVG

*:Maximum data x:Over limit !:over margin

●Reference Only



EUT : Wireless 802.11b/g ADSL2+ Router
Model No. : TW263R4
Test Mode : IEEE 802.11g Link Mode Low CH & High CH
Test Date : 09/07/2009

Please refer to next page of detail testing data.

Notes:

1. Margin= Amplitude - Limits
2. Height of table for EUT placed: 0.8 Meter.
3. ANT= Antenna height.
4. Duty= Duty cycle correction factor.
5. Dis= Distance extrapolation factor.
6. Amplitude= Reading Amplitude – Amplifier gain + Cable loss + Antenna factor
(Auto calculate in spectrum analyzer)
7. Actual Amp= Amplitude – Duty – Dis.



File :FCC(BAND EDGE)power 10
125.0 dBuV

Data :#1

Date:2009/9/7

Time: 下午 01:42:22

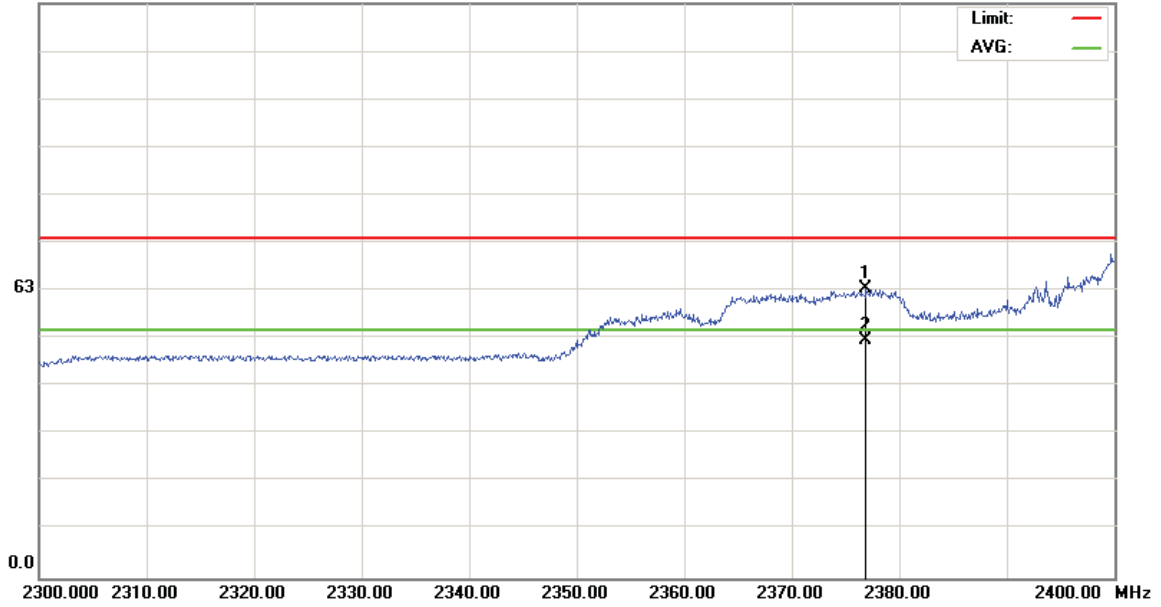

Site Polarization: *Vertical* Temperature: 22 °C
 Limit: FCC part 15 (PK) Power: Humidity: 60 %
 EUT: Distance: 3m
 M/N: 09-0216-EP
 Mode: BAND EDGE(11g)
 Note: CH01(2412MHz)

No.	Mk.	Freq. MHz	Reading Level dBuV	Correct Factor dB	Measure- ment dBuV	Limit dBuV	Over dB	Antenna Height cm	Table Degree degree	Comment
1		2376.900	62.93	0.16	63.09	74.00	-10.91	peak		
2	*	2376.900	51.48	0.16	51.64	54.00	-2.36	AVG		

*:Maximum data x:Over limit !:over margin

●Reference Only



File :FCC(BAND EDGE)power 10
117.0 dBuV

Data :#5

Date:2009/9/7

Time: 下午 01:48:26

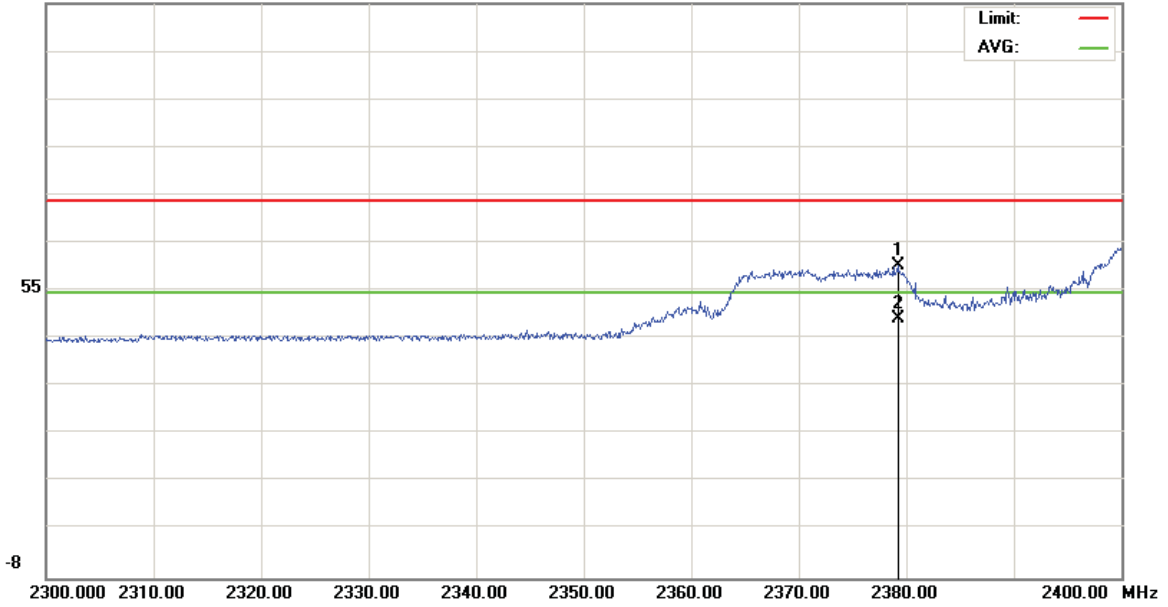

Site Polarization: *Horizontal* Temperature: 22 °C
 Limit: FCC part 15 (PK) Power: Humidity: 60 %
 EUT: Distance: 3m
 M/N: 09-0216-EP
 Mode: BAND EDGE(11g)
 Note: CH01(2412MHz)

No.	Mk.	Freq.	Reading Level	Correct Factor	Measurement	Limit	Over	Antenna Height	Table Degree	
		MHz	dBuV	dB	dBuV	dBuV	dB	cm	degree	Comment
1		2379.200	59.90	0.17	60.07	74.00	-13.93			peak
2	*	2379.200	48.16	0.17	48.33	54.00	-5.67			AVG

*:Maximum data x:Over limit !:over margin

●Reference Only



File :FCC(BAND EDGE)power 10
125.0 dBuV

Data :#3

Date:2009/9/7

Time: 下午 01:57:01

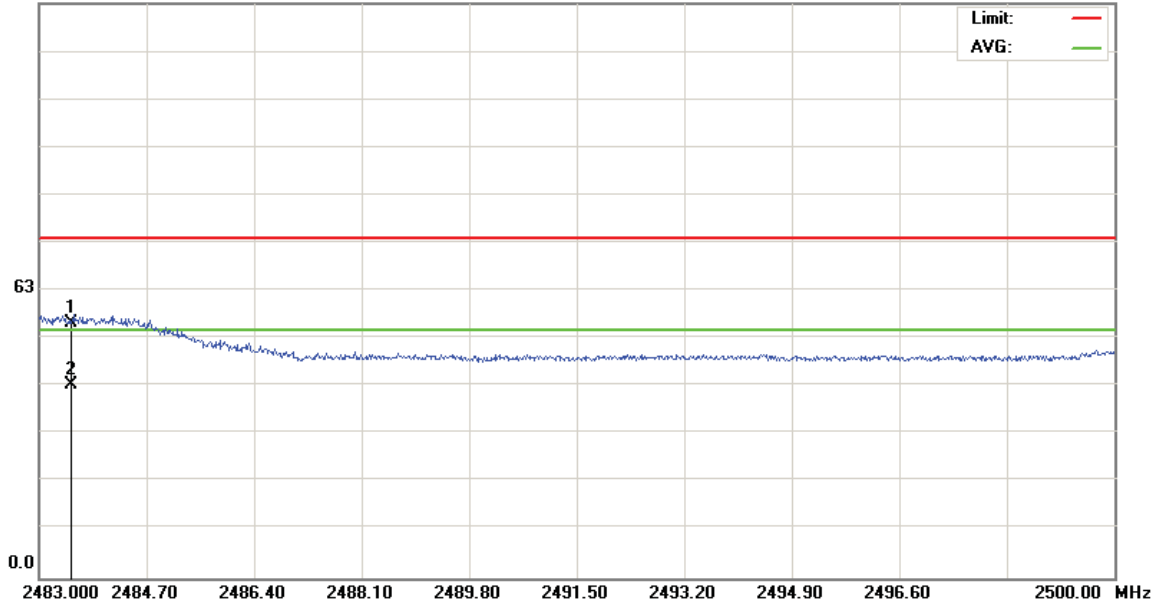

Site Polarization: *Vertical* Temperature: 22 °C
 Limit: FCC part 15 (PK) Power: Humidity: 60 %
 EUT: Distance: 3m
 M/N: 09-0216-EP
 Mode: BAND EDGE(11g)
 Note: CH11(2462MHz)

No.	Mk.	Freq.	Reading Level	Correct Factor	Measurement	Limit	Over	Antenna Height	Table Degree	
		MHz	dBuV	dB	dBuV	dBuV	dB	cm	degree	Comment
1		2483.500	55.14	0.25	55.39	74.00	-18.61			peak
2	*	2483.500	41.92	0.25	42.17	54.00	-11.83			AVG

*:Maximum data x:Over limit !:over margin

●Reference Only



File :FCC(BAND EDGE)power 10
125.0 dBuV

Data :#7

Date:2009/9/7

Time: 下午 01:54:00

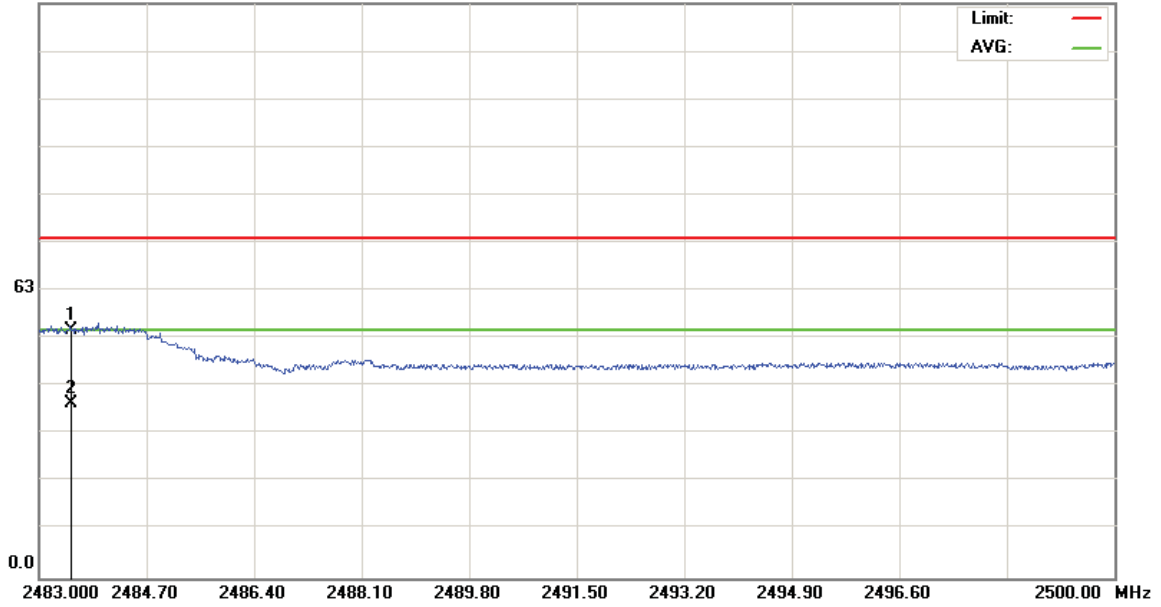

Site Polarization: *Horizontal* Temperature: 22 °C
 Limit: FCC part 15 (PK) Power: Humidity: 60 %
 EUT: Distance: 3m
 M/N: 09-0216-EP
 Mode: BAND EDGE(11g)
 Note: CH11(2462MHz)

No.	Mk.	Freq.	Reading Level	Correct Factor	Measurement	Limit	Over	Antenna Height	Table Degree	
		MHz	dBuV	dB	dBuV	dBuV	dB	cm	degree	Comment
1		2483.500	53.70	0.25	53.95	74.00	-20.05			peak
2	*	2483.500	37.83	0.25	38.08	54.00	-15.92			AVG

*:Maximum data x:Over limit !:over margin

●Reference Only



9. Antenna Requirements

9.1 Standard Applicable

For intentional device, according to 15.203, an intentional radiator shall be designed to ensure that no antenna other than that furnished by the responsible party shall be used with the device.

And According to 15.247 (b), if transmitting antennas of directional gain greater than 6 dBi are used, the power shall be reduced by the amount in dB that the directional gain of the antenna exceeds 6dBi.

9.2 Antenna Connector Construction

The antenna used in this product is **External Antenna**. And the maximum Gain of this antenna is only **3.5dBi**.