

## ELECTROMAGNETIC EMISSIONS COMPLIANCE REPORT

### INTENTIONAL RADIATOR CERTIFICATION TO FCC PART 15 SUBPART C REQUIREMENT INDUSTRY CANADA RSS-210

OF

**Product Name:** POS terminal

**Brand Name:** ingenico

**Model Name:** iPA280

**Model Differences:** N/A

**FCC ID:** XKBIPA280

**IC:** 2586D-IPA280

**Report No.:** EH/2009/30024

**Issue Date:** Dec. 04, 2009

**FCC Rule Part:** §15.225

**IC Rule Part:** RSS-210 issue 7:2007, Annex 2 A2.6

**Prepared for:** INGENICO  
1 rue Claude Chappe BP346. 07503  
Guilherand-Granges – France

**Prepared by:** SGS Taiwan Ltd.  
Electronics & Communication Laboratory  
No. 134, Wu Kung Rd., Wuku Industrial  
Zone, Taipei County, Taiwan



*Note: This report shall not be reproduced except in full, without the written approval of SGS Taiwan Ltd. This document may be altered or revised by SGS Taiwan Ltd. personnel only, and shall be noted in the revision section of the document.*

## VERIFICATION OF COMPLIANCE

**Applicant:** INGENICO  
1 rue Claude Chappe BP346. 07503 Guilherand-Granges – France

**Product Name:** POS terminal

**FCC ID:** XKBIPA280

**IC:** 2586D-IPA280

**Brand Name:** ingenico

**Model No.:** iPA280

**Model Difference:** N/A

**File Number:** EH/2009/30024

**Date of Test:** Nov. 25, 2009 ~ Dec. 03, 2009

**Date of EUT Received:** Mar. 27, 2009

### We hereby certify that:

The above equipment was tested by SGS Taiwan Ltd. Electronics & Communication Laboratory. The test data, data evaluation, test procedures, and equipment configurations shown in this report were made in accordance with the procedures given in ANSI C63.4 (2003) and the energy emitted by the sample EUT tested as described in this report is in compliance with conducted and radiated emission limits of FCC Rules Part 15.225 and RSS-210 issue 7: 2007 Annex 2 A2.6

The test results of this report relate only to the tested sample identified in this report

*Test By:*

*Jazz Huang*

*Date:*

Dec. 04, 2009

*Jazz Huang / Engineer*

*Prepared By:*

*Gigi yeh*

*Date:*

Dec. 04, 2009

*Gigi Yeh / Clerk*

*Approved By:*

*Vincent Su*

*Date:*

Dec. 04, 2009

*Vincent Su / Manager*

Unless otherwise stated the results shown in this test report refer only to the sample(s) tested and such sample(s) are retained for 90 days only. This test report cannot be reproduced, except in full, without prior written permission of the Company. 除非另有說明，此報告結果僅對測試之樣品負責，同時此樣品僅保留90天。本報告未經本公司書面許可，不可部份複製。

This document is issued by the Company subject to its General Conditions of Service ([www.sgs.com/terms\\_and\\_conditions.htm](http://www.sgs.com/terms_and_conditions.htm)) and Terms and Conditions for Electronic Documents ([www.sgs.com/terms\\_e-document.htm](http://www.sgs.com/terms_e-document.htm)). Attention is drawn to the limitations of liability, indemnification and jurisdictional issues established therein. Even if printed this electronic document is to be treated as an original within the meaning of UCP 600 article 20b. The authenticity of this document may be verified at [www.sgsonsite.com/authentication](http://www.sgsonsite.com/authentication). Any holder of this document is advised that information contained hereon reflects the Company's findings at the time of its intervention only and within the limits of client's instructions, if any. The Company's sole responsibility is to its Client and this document does not exonerate parties to a transaction from exercising all their rights and obligations under the transaction documents.

## Version

Version No.	Date	Description
00	Dec. 04, 2009	Initial creation of document

Unless otherwise stated the results shown in this test report refer only to the sample(s) tested and such sample(s) are retained for 90 days only. This test report cannot be reproduced, except in full, without prior written permission of the Company. 除非另有說明，此報告結果僅對測試之樣品負責，同時此樣品僅保留90天。本報告未經本公司書面許可，不可部份複製。

This document is issued by the Company subject to its General Conditions of Service ([www.sgs.com/terms\\_and\\_conditions.htm](http://www.sgs.com/terms_and_conditions.htm)) and Terms and Conditions for Electronic Documents ([www.sgs.com/terms\\_e-document.htm](http://www.sgs.com/terms_e-document.htm)). Attention is drawn to the limitations of liability, indemnification and jurisdictional issues established therein. Even if printed this electronic document is to be treated as an original within the meaning of UCP 600 article 20b. The authenticity of this document may be verified at [www.sgonsite.com/authentication](http://www.sgonsite.com/authentication). Any holder of this document is advised that information contained hereon reflects the Company's findings at the time of its intervention only and within the limits of client's instructions, if any. The Company's sole responsibility is to its Client and this document does not exonerate parties to a transaction from exercising all their rights and obligations under the transaction documents.

## Table of Contents

<b>1</b>	<b>GENERAL INFORMATION .....</b>	<b>5</b>
1.1	PRODUCT DESCRIPTION .....	5
1.2	RELATED SUBMITTAL(S) / GRANT (S).....	8
1.3	TEST METHODOLOGY .....	8
1.4	TEST FACILITY .....	8
1.5	SPECIAL ACCESSORIES .....	8
1.6	EQUIPMENT MODIFICATIONS.....	8
<b>2</b>	<b>SYSTEM TEST CONFIGURATION .....</b>	<b>9</b>
2.1	EUT CONFIGURATION .....	9
2.2	EUT EXERCISE.....	9
2.3	TEST PROCEDURE .....	9
2.4	LIMITATION .....	10
2.5	CONFIGURATION OF TESTED SYSTEM .....	12
<b>3</b>	<b>SUMMARY OF TEST RESULTS.....</b>	<b>13</b>
<b>4</b>	<b>DESCRIPTION OF TEST MODES.....</b>	<b>13</b>
<b>5</b>	<b>CONDUCTED EMISSIONS TEST.....</b>	<b>14</b>
5.1	MEASUREMENT PROCEDURE:.....	14
5.2	TEST SET-UP (BLOCK DIAGRAM OF CONFIGURATION).....	14
5.3	MEASUREMENT EQUIPMENT USED:.....	14
5.4	MEASUREMENT RESULT:.....	14
<b>6</b>	<b>RADIATED EMISSION TEST .....</b>	<b>17</b>
6.1	MEASUREMENT PROCEDURE .....	17
6.2	TEST SET-UP (BLOCK DIAGRAM OF CONFIGURATION).....	17
6.3	MEASUREMENT EQUIPMENT USED:.....	18
6.4	FIELD STRENGTH CALCULATION.....	18
6.5	MEASUREMENT RESULT .....	19
<b>7</b>	<b>FREQUENCY TOLERANCE .....</b>	<b>25</b>
7.1	MEASUREMENT PROCEDURE.....	25
7.2	TEST SET-UP (BLOCK DIAGRAM OF CONFIGURATION).....	25
7.3	MEASUREMENT EQUIPMENT USED:.....	25
7.4	MEASUREMENT RESULTS .....	25
<b>8. 99% OCCUPIED BANDWIDTH MEASUREMENT .....</b>		<b>27</b>
8.1	TEST SET-UP: .....	27
8.2	MEASUREMENT PROCEDURE: .....	27
8.3	MEASUREMENT EQUIPMENT USED:.....	27

Unless otherwise stated the results shown in this test report refer only to the sample(s) tested and such sample(s) are retained for 90 days only. This test report cannot be reproduced, except in full, without prior written permission of the Company. 除非另有說明，此報告結果僅對測試之樣品負責，同時此樣品僅保留90天。本報告未經本公司書面許可，不可部份複製。

This document is issued by the Company subject to its General Conditions of Service ([www.sgs.com/terms\\_and\\_conditions.htm](http://www.sgs.com/terms_and_conditions.htm)) and Terms and Conditions for Electronic Documents ([www.sgs.com/terms\\_e-document.htm](http://www.sgs.com/terms_e-document.htm)). Attention is drawn to the limitations of liability, indemnification and jurisdictional issues established therein. Even if printed this electronic document is to be treated as an original within the meaning of UCP 600 article 20b. The authenticity of this document may be verified at [www.sgsonsite.com/authentication](http://www.sgsonsite.com/authentication). Any holder of this document is advised that information contained hereon reflects the Company's findings at the time of its intervention only and within the limits of client's instructions, if any. The Company's sole responsibility is to its Client and this document does not exonerate parties to a transaction from exercising all their rights and obligations under the transaction documents.

## 1 GENERAL INFORMATION

### 1.1 Product Description

General:

Product Name:	POS terminal	
Brand Name:	ingenico	
Model Name:	iPA280	
Model Difference:	N/A	
Power Supply	3.6 Vdc re-chargeable battery or 5Vdc by AC/DC power adapter	
	Battery:	Model: IPA200-BAT, Supplier: ingenico
	Adapter:	Model: T010WM0512

GSM / DCS:

	Operation Band	Frequency Range	Rated Power
Cellular Phone Standards Frequency Range and Power	GSM/ EDGE 850 Class 10	824.2 MHz– 848.8 MHz	33 dBm
	GSM/ EDGE 900 Class 10	880.2MHz – 914.8MHz	33 dBm
	GSM/ EDGE 1800 Class 10	1710.2MHz – 1784.8MHz	30 dBm
	GSM/ EDGE 1900 Class 10	1850.2MHz – 1909.8MHz	30 dBm
Type of Emission	300KGXW		
Hardware Version	PVT		
Software Version	0.34.00.Q		
IMEI	354060011335375		

Unless otherwise stated the results shown in this test report refer only to the sample(s) tested and such sample(s) are retained for 90 days only. This test report cannot be reproduced, except in full, without prior written permission of the Company. 除非另有說明，此報告結果僅對測試之樣品負責，同時此樣品僅保留90天。本報告未經本公司書面許可，不可部份複製。

This document is issued by the Company subject to its General Conditions of Service ([www.sgs.com/terms\\_and\\_conditions.htm](http://www.sgs.com/terms_and_conditions.htm)) and Terms and Conditions for Electronic Documents ([www.sgs.com/terms\\_e-document.htm](http://www.sgs.com/terms_e-document.htm)). Attention is drawn to the limitations of liability, indemnification and jurisdictional issues established therein. Even if printed this electronic document is to be treated as an original within the meaning of UCP 600 article 20b. The authenticity of this document may be verified at [www.sgsonsite.com/authentication](http://www.sgsonsite.com/authentication). Any holder of this document is advised that information contained hereon reflects the Company's findings at the time of its intervention only and within the limits of client's instructions, if any. The Company's sole responsibility is to its Client and this document does not exonerate parties to a transaction from exercising all their rights and obligations under the transaction documents.

WLAN:

Frequency Range:	2412 – 2462 MHz
Channel number:	11 channels
Max. Output Power:	802.11 b: 15.35 dBm (Peak) 802.11 g: 14.83 dBm (Peak)
Modulation Technology:	DSSS, OFDM
Modulation type:	CCK, DQPSK, DBPSK for DSSS 64QAM, 16QAM, QPSK, BPSK for OFDM
Transition Rate:	802.11 b: 1/2/5.5/11 Mbps; 802.11 g: 6/9/12/18/24/36/48/54 Mbps
Antenna Designation:	PIFA Antenna / -0.51dBi.

The EUT is compliance with IEEE 802.11 b/g Standard.

Bluetooth:

Bluetooth Version	<input type="checkbox"/> V1.1 (GFSK) <input type="checkbox"/> V1.2 (GFSK) <input type="checkbox"/> V2.0 (GFSK) <input type="checkbox"/> V2.0 + EDR (GFSK + /4DQPSK + 8DPSK) <input checked="" type="checkbox"/> V2.1 + EDR (GFSK + /4DQPSK + 8DPSK)
Frequency Range	2402 – 2480MHz
Channel number	79 channels max.
Rated Power	1.74 dBm (Peak)
Modulation type	Frequency Hopping Spread Spectrum
Antenna Designation	PIFA Antenna / -0.42dBi.

The EUT is compliance with Bluetooth 2.1 Standard.

Unless otherwise stated the results shown in this test report refer only to the sample(s) tested and such sample(s) are retained for 90 days only. This test report cannot be reproduced, except in full, without prior written permission of the Company. 除非另有說明，此報告結果僅對測試之樣品負責，同時此樣品僅保留90天。本報告未經本公司書面許可，不可部份複製。

This document is issued by the Company subject to its General Conditions of Service ([www.sgs.com/terms\\_and\\_conditions.htm](http://www.sgs.com/terms_and_conditions.htm)) and Terms and Conditions for Electronic Documents ([www.sgs.com/terms\\_e-document.htm](http://www.sgs.com/terms_e-document.htm)). Attention is drawn to the limitations of liability, indemnification and jurisdictional issues established therein. Even if printed this electronic document is to be treated as an original within the meaning of UCP 600 article 20b. The authenticity of this document may be verified at [www.sgsonsite.com/authentication](http://www.sgsonsite.com/authentication). Any holder of this document is advised that information contained hereon reflects the Company's findings at the time of its intervention only and within the limits of client's instructions, if any. The Company's sole responsibility is to its Client and this document does not exonerate parties to a transaction from exercising all their rights and obligations under the transaction documents.

RFID:

Operating Frequency	13.56MHz
Transmit Power	< 123dBuV/m at 3m.
Number of Channels	1
Operating Mode	Point-to-Point
Antenna Type	Print antenna
Module Type	ASK

The EUT is compliance with RFID Standard.

GPS:

Receiver Frequency	L1 Band, 1575.42MHz
Frequency Conversion oscillator	26MHz
Antenna Designation	Patch antenna

This report applies for RFID.

Unless otherwise stated the results shown in this test report refer only to the sample(s) tested and such sample(s) are retained for 90 days only. This test report cannot be reproduced, except in full, without prior written permission of the Company. 除非另有說明，此報告結果僅對測試之樣品負責，同時此樣品僅保留90天。本報告未經本公司書面許可，不可部份複製。

This document is issued by the Company subject to its General Conditions of Service ([www.sgs.com/terms\\_and\\_conditions.htm](http://www.sgs.com/terms_and_conditions.htm)) and Terms and Conditions for Electronic Documents ([www.sgs.com/terms\\_e-document.htm](http://www.sgs.com/terms_e-document.htm)). Attention is drawn to the limitations of liability, indemnification and jurisdictional issues established therein. Even if printed this electronic document is to be treated as an original within the meaning of UCP 600 article 20b. The authenticity of this document may be verified at [www.sgsonsite.com/authentication](http://www.sgsonsite.com/authentication). Any holder of this document is advised that information contained hereon reflects the Company's findings at the time of its intervention only and within the limits of client's instructions, if any. The Company's sole responsibility is to its Client and this document does not exonerate parties to a transaction from exercising all their rights and obligations under the transaction documents.

## 1.2 Related Submittal(s) / Grant (s)

This submittal(s) (test report) is intended for **FCC ID: XKBIPA280** filing to comply with Section 15.225 of the FCC Part 15, Subpart C Rules and **IC: 2586D-IPA280** filing to comply with Industry Canada RSS-210 issue 7: 2007 Annex 2 A2.6. The composite system (digital device) is compliance with Subpart B is authorized under a DoC procedure..

## 1.3 Test Methodology

Both conducted and radiated testing were performed according to the procedures in ANSI C63.4 (2003) and RSS-Gen: 2007.. Radiated testing was performed at an antenna to EUT distance 3 meters.

## 1.4 Test Facility

The measurement facilities used to collect the 3m Radiated Emission and AC power line conducted data are located on the address of SGS Taiwan Ltd. Electronics & Communication Laboratory No. 134, Wu Kung Rd., Wuku Industrial Zone, Taipei Country, Taiwan which are constructed and calibrated to meet the FCC requirements in documents ANSI C63.4: 2003. FCC Registration Number are: 990257 and 236194, Canada Registration Number: 4620A-1.

The 10 m Open Area Test Sites located on the address of SGS Taiwan Ltd. Electronics & Communication Laboratory No. 29, Pau-Tou-Tsuo Valley Chia-Pau Tsuen, Linkou Hsiang, Taipei county, which is constructed and calibrated to meet the CISPR 22/EN 55022 requirements. SGS Site No. 1(3 &10 meters) and FCC Registration Number: 94644.

## 1.5 Special Accessories

Not available for this EUT intended for grant.

## 1.6 Equipment Modifications

Not available for this EUT intended for grant.

Unless otherwise stated the results shown in this test report refer only to the sample(s) tested and such sample(s) are retained for 90 days only. This test report cannot be reproduced, except in full, without prior written permission of the Company. 除非另有說明，此報告結果僅對測試之樣品負責，同時此樣品僅保留90天。本報告未經本公司書面許可，不可部份複製。

This document is issued by the Company subject to its General Conditions of Service ([www.sgs.com/terms\\_and\\_conditions.htm](http://www.sgs.com/terms_and_conditions.htm)) and Terms and Conditions for Electronic Documents ([www.sgs.com/terms\\_e-document.htm](http://www.sgs.com/terms_e-document.htm)). Attention is drawn to the limitations of liability, indemnification and jurisdictional issues established therein. Even if printed this electronic document is to be treated as an original within the meaning of UCP 600 article 20b. The authenticity of this document may be verified at [www.sgsonsite.com/authentication](http://www.sgsonsite.com/authentication). Any holder of this document is advised that information contained hereon reflects the Company's findings at the time of its intervention only and within the limits of client's instructions, if any. The Company's sole responsibility is to its Client and this document does not exonerate parties to a transaction from exercising all their rights and obligations under the transaction documents.



## 2 System Test Configuration

### 2.1 EUT Configuration

The EUT configuration for testing is installed on RF field strength measurement to meet the Commissions requirement and operating in a manner which intends to maximize its emission characteristics in a continuous normal application.

### 2.2 EUT Exercise

The Transmitter was operated in the normal operating mode. the Tx frequency was fixed which was for the purpose of the measurements.

### 2.3 Test Procedure

#### 2.3.1 Conducted Emissions

The EUT is a placed on as turn table which is 0.8 m above ground plane. According to the requirements in Section 7 and 13 of ANSI C63.4-2003. Conducted emissions from the EUT measured in the frequency range between 0.15 MHz and 30MHz using CISPR Quasi-Peak and average detector mode.

#### 2.3.2 Radiated Emissions

The EUT is a placed on as turn table which is 0.8 m above ground plane. The turn table shall rotate 360 degrees to determine the position of maximum emission level. EUT is set 3m away from the receiving antenna which varied from 1m to 4m to find out the highest emission. And also, each emission was to be maximized by changing the polarization of receiving antenna both horizontal and vertical. In order to find out the max. emission, the relative positions of this hand-held transmitter(EUT) was rotated through three orthogonal axes according to the requirements in Section 8 and 13 of ANSI C63.4-2003.

Unless otherwise stated the results shown in this test report refer only to the sample(s) tested and such sample(s) are retained for 90 days only. This test report cannot be reproduced, except in full, without prior written permission of the Company. 除非另有說明，此報告結果僅對測試之樣品負責，同時此樣品僅保留90天。本報告未經本公司書面許可，不可部份複製。

This document is issued by the Company subject to its General Conditions of Service ([www.sgs.com/terms\\_and\\_conditions.htm](http://www.sgs.com/terms_and_conditions.htm)) and Terms and Conditions for Electronic Documents ([www.sgs.com/terms\\_e-document.htm](http://www.sgs.com/terms_e-document.htm)). Attention is drawn to the limitations of liability, indemnification and jurisdictional issues established therein. Even if printed this electronic document is to be treated as an original within the meaning of UCP 600 article 20b. The authenticity of this document may be verified at [www.sgsonsite.com/authentication](http://www.sgsonsite.com/authentication). Any holder of this document is advised that information contained hereon reflects the Company's findings at the time of its intervention only and within the limits of client's instructions, if any. The Company's sole responsibility is to its Client and this document does not exonerate parties to a transaction from exercising all their rights and obligations under the transaction documents.

## 2.4 Limitation

### (1) Conducted Emission

According to section 15.207(a) Conducted Emission Limits is as following.

Frequency range MHz	Limits dB (uV)	
	Quasi-peak	Average
0.15 to 0.50	66 to 56	56 to 46
0.50 to 5	56	46
5 to 30	60	50

Note

- 1.The lower limit shall apply at the transition frequencies
- 2.The limit decreases linearly with the logarithm of the frequency in the range 0.15 MHz to 0.50 MHz.

### (2) Radiated Emission

- a. The field strength of any emission within the band 13.553-13.567 MHz shall not exceed 15,848 microvolts/meter at 30 meters.
- b. Within the bands 13.410-13.553 MHz and 13.567-13.710 MHz, the field strength of any emissions shall not exceed 334 microvolts/meter at 30 meters.
- c. Within the bands 13.110-13.410 MHz and 13.710-14.010 MHz the field strength of any emissions shall not exceed 106 microvolts/meter at 30 meters.
- d. The field strength of any emissions appearing outside of the 13.110-14.010 MHz shall not exceed the general radiated emission limits in section 15.209(Intentional Radiators general limit).as below.

Frequency (MHz)	Field strength $\mu\text{V/m}$	Distance (m)	Field strength at 3m $\text{dB}\mu\text{V/m}$
1.705-30	30	30	69.54
30-88	100	3	40
88-216	150	3	43.5
216-960	200	3	46
Above 960	500	3	54

Unless otherwise stated the results shown in this test report refer only to the sample(s) tested and such sample(s) are retained for 90 days only. This test report cannot be reproduced, except in full, without prior written permission of the Company. 除非另有說明，此報告結果僅對測試之樣品負責，同時此樣品僅保留90天。本報告未經本公司書面許可，不可部份複製。

This document is issued by the Company subject to its General Conditions of Service ([www.sgs.com/terms\\_and\\_conditions.htm](http://www.sgs.com/terms_and_conditions.htm)) and Terms and Conditions for Electronic Documents ([www.sgs.com/terms\\_e-document.htm](http://www.sgs.com/terms_e-document.htm)). Attention is drawn to the limitations of liability, indemnification and jurisdictional issues established therein. Even if printed this electronic document is to be treated as an original within the meaning of UCP 600 article 20b. The authenticity of this document may be verified at [www.sgsonsite.com/authentication](http://www.sgsonsite.com/authentication). Any holder of this document is advised that information contained hereon reflects the Company's findings at the time of its intervention only and within the limits of client's instructions, if any. The Company's sole responsibility is to its Client and this document does not exonerate parties to a transaction from exercising all their rights and obligations under the transaction documents.

- Remark:
1. Emission level in dBuV/m=20 log (uV/m)
  2. Measurement was performed at an antenna to the closed point of EUT distance of meters.
  3. Only spurious frequency is permitted to locate within the Restricted Bands specified in provision of  $\xi$  15.205 & RSS210 2.2.7
  4. Emission spurious frequency which appearing within the Restricted Bands specified in provision of  $\xi$ 15.205 &RSS210 2.2.7, then the general radiated emission limits in  $\xi$  15.209 & RSS210 2.2.7

### (3) Frequency Tolerance

The frequency tolerance of the carrier signal shall be maintained within +/- 0.01% of the operating frequency over a temperature variation of 5 degrees to +50 degrees C at normal supply voltage, and for a variation in the primary supply voltage from 85% to 115% of the rated supply voltage at a temperature of 20 degrees C. For battery operated equipment, the equipment tests shall be performed using a new battery.

Unless otherwise stated the results shown in this test report refer only to the sample(s) tested and such sample(s) are retained for 90 days only. This test report cannot be reproduced, except in full, without prior written permission of the Company. 除非另有說明，此報告結果僅對測試之樣品負責，同時此樣品僅保留90天。本報告未經本公司書面許可，不可部份複製。

This document is issued by the Company subject to its General Conditions of Service ([www.sgs.com/terms\\_and\\_conditions.htm](http://www.sgs.com/terms_and_conditions.htm)) and Terms and Conditions for Electronic Documents ([www.sgs.com/terms\\_e-document.htm](http://www.sgs.com/terms_e-document.htm)). Attention is drawn to the limitations of liability, indemnification and jurisdictional issues established therein. Even if printed this electronic document is to be treated as an original within the meaning of UCP 600 article 20b. The authenticity of this document may be verified at [www.sgsonsite.com/authentication](http://www.sgsonsite.com/authentication). Any holder of this document is advised that information contained hereon reflects the Company's findings at the time of its intervention only and within the limits of client's instructions, if any. The Company's sole responsibility is to its Client and this document does not exonerate parties to a transaction from exercising all their rights and obligations under the transaction documents.

## 2.5 Configuration of Tested System

Fig. 2-1 Configuration of Tested System



Table 2-1 Equipment Used in Tested System

Equipment	Mfr/Brand	Model/ Type No.	FCC ID	Series No.
Adaptor	LEI	1U18-2050200-WP	N/A	N/A

Unless otherwise stated the results shown in this test report refer only to the sample(s) tested and such sample(s) are retained for 90 days only. This test report cannot be reproduced, except in full, without prior written permission of the Company. 除非另有說明，此報告結果僅對測試之樣品負責，同時此樣品僅保留90天。本報告未經本公司書面許可，不可部份複製。

This document is issued by the Company subject to its General Conditions of Service ([www.sgs.com/terms\\_and\\_conditions.htm](http://www.sgs.com/terms_and_conditions.htm)) and Terms and Conditions for Electronic Documents ([www.sgs.com/terms\\_e-document.htm](http://www.sgs.com/terms_e-document.htm)). Attention is drawn to the limitations of liability, indemnification and jurisdictional issues established therein. Even if printed this electronic document is to be treated as an original within the meaning of UCP 600 article 20b. The authenticity of this document may be verified at [www.sgsonsite.com/authentication](http://www.sgsonsite.com/authentication). Any holder of this document is advised that information contained hereon reflects the Company's findings at the time of its intervention only and within the limits of client's instructions, if any. The Company's sole responsibility is to its Client and this document does not exonerate parties to a transaction from exercising all their rights and obligations under the transaction documents.

### 3 Summary of Test Results

FCC Rules	Description Of Test	Result
§15.207 & RSS-Gen §7.2.2	Conducted Emission	Compliant
§15.225 (a), (d) & RSS210 2.2.7	Radiated Emission	Compliant
§15.225 (e) & RSS210 Annex 2 A2.6	Frequency Stability	Compliant

### 4 Description of test modes

The EUT stay in continuous transmitting mode. The frequency 13.56 MHz is chosen for radiated emission testing.

Unless otherwise stated the results shown in this test report refer only to the sample(s) tested and such sample(s) are retained for 90 days only. This test report cannot be reproduced, except in full, without prior written permission of the Company. 除非另有說明，此報告結果僅對測試之樣品負責，同時此樣品僅保留90天。本報告未經本公司書面許可，不可部份複製。

This document is issued by the Company subject to its General Conditions of Service ([www.sgs.com/terms\\_and\\_conditions.htm](http://www.sgs.com/terms_and_conditions.htm)) and Terms and Conditions for Electronic Documents ([www.sgs.com/terms\\_e-document.htm](http://www.sgs.com/terms_e-document.htm)). Attention is drawn to the limitations of liability, indemnification and jurisdictional issues established therein. Even if printed this electronic document is to be treated as an original within the meaning of UCP 600 article 20b. The authenticity of this document may be verified at [www.sgsonsite.com/authentication](http://www.sgsonsite.com/authentication). Any holder of this document is advised that information contained hereon reflects the Company's findings at the time of its intervention only and within the limits of client's instructions, if any. The Company's sole responsibility is to its Client and this document does not exonerate parties to a transaction from exercising all their rights and obligations under the transaction documents.

## 5 Conducted Emissions Test

### 5.1 Measurement Procedure:

1. The EUT was placed on a table which is 0.8m above ground plane.
2. Maximum procedure was performed on the six highest emissions to ensure EUT compliance.
3. Repeat above procedures until all frequency measured were complete.

### 5.2 Test SET-UP (Block Diagram of Configuration)

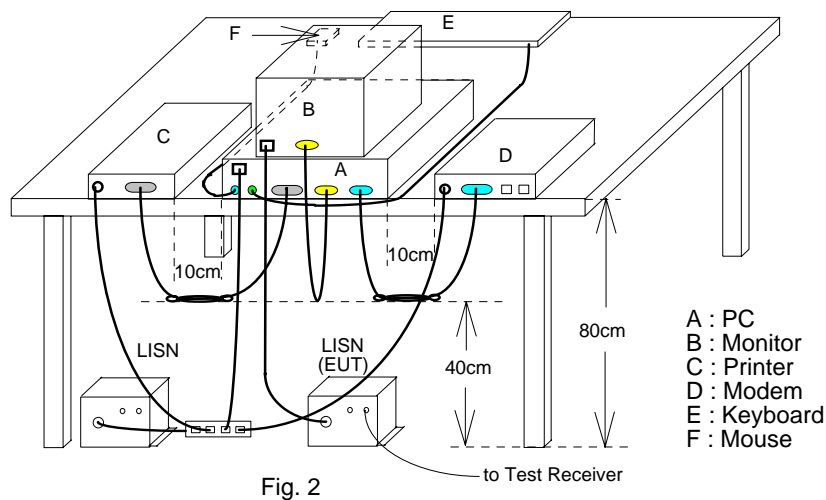

### 5.3 Measurement Equipment Used:

Conducted Emission Test Site					
EQUIPMENT TYPE	MFR	MODEL NUMBER	SERIAL NUMBER	LAST CAL.	CAL DUE.
EMI Test Receiver	R&S	ESCS30	828985/004	09/16/2009	09/15/2010
LISN	Rolf-Heine	NNB-2/16Z	99012	04/28/2009	04/27/2010
LISN	FCC	FCC-LISN-50/250-25-2-01	04034	04/28/2009	04/27/2010
Coaxial Cables	N/A	WK CE Cable	N/A	10/30/2009	10/29/2010

### 5.4 Measurement Result:

The initial step in collecting conducted data is a spectrum analyzer peak scan of the measurement range. Significant peaks are then marked as shown on the following data page, and these signals are then quasi-peak.

### AC POWER LINE CONDUCTED EMISSION TEST DATA

Operation Mode:	RFID Operation Mode		Test Date:	Nov. 26, 2009	
Temperature:	23 °C	Humidity:	60 %	Test By:	Jazz

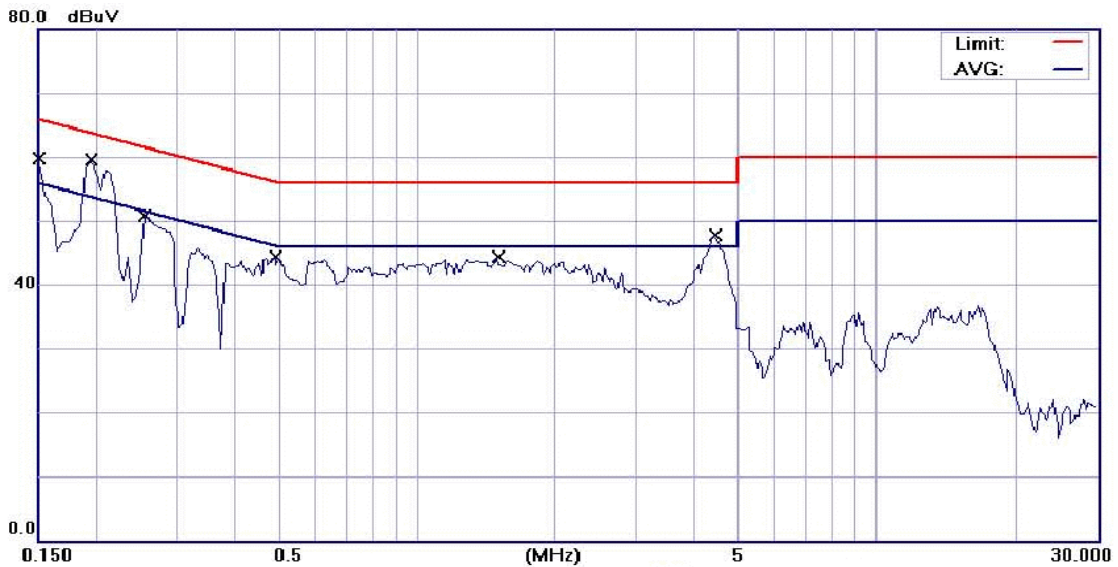

Site: SGS CONDUCTED #1	Phase: <b>L1</b>	Temperature: 23 °C
Limit: CISPR11 Class B Conduction(QP)	Power: AC 120V/60Hz	Humidity: 60 %
EUT: POS terminal	Distance:	Air Pressure: hpa
M/N: M81B		
Note: NFC Operation mode		

No.	Mk.	Freq.	Reading Level	Factor	Measurement	Limit	Over	Detector	Comment
		MHz	dBuV	dB	dBuV	dBuV	dB		
1		0.1500	52.00	0.18	52.18	66.00	-13.82	QP	
2		0.1500	38.00	0.18	38.18	56.00	-17.82	AVG	
3	*	0.1950	55.60	0.13	55.73	63.82	-8.09	QP	
4		0.1950	41.10	0.13	41.23	53.82	-12.59	AVG	
5		0.2550	47.10	0.11	47.21	61.59	-14.38	QP	
6		0.2550	35.20	0.11	35.31	51.59	-16.28	AVG	
7		0.4900	41.20	0.07	41.27	56.17	-14.90	QP	
8		0.4900	28.90	0.07	28.97	46.17	-17.20	AVG	
9		1.5000	40.30	0.11	40.41	56.00	-15.59	QP	
10		1.5000	30.10	0.11	30.21	46.00	-15.79	AVG	
11		4.4400	43.80	0.16	43.96	56.00	-12.04	QP	
12		4.4400	32.00	0.16	32.16	46.00	-13.84	AVG	

Unless otherwise stated the results shown in this test report refer only to the sample(s) tested and such sample(s) are retained for 90 days only. This test report cannot be reproduced, except in full, without prior written permission of the Company. 除非另有說明，此報告結果僅對測試之樣品負責，同時此樣品僅保留90天。本報告未經本公司書面許可，不可部份複製。  
This document is issued by the Company subject to its General Conditions of Service ([www.sgs.com/terms\\_and\\_conditions.htm](http://www.sgs.com/terms_and_conditions.htm)) and Terms and Conditions for Electronic Documents ([www.sgs.com/terms\\_e-document.htm](http://www.sgs.com/terms_e-document.htm)). Attention is drawn to the limitations of liability, indemnification and jurisdictional issues established therein. Even if printed this electronic document is to be treated as an original within the meaning of UCP 600 article 20b. The authenticity of this document may be verified at [www.sgsonsite.com/authentication](http://www.sgsonsite.com/authentication). Any holder of this document is advised that information contained hereon reflects the Company's findings at the time of its intervention only and within the limits of client's instructions, if any. The Company's sole responsibility is to its Client and this document does not exonerate parties to a transaction from exercising all their rights and obligations under the transaction documents.

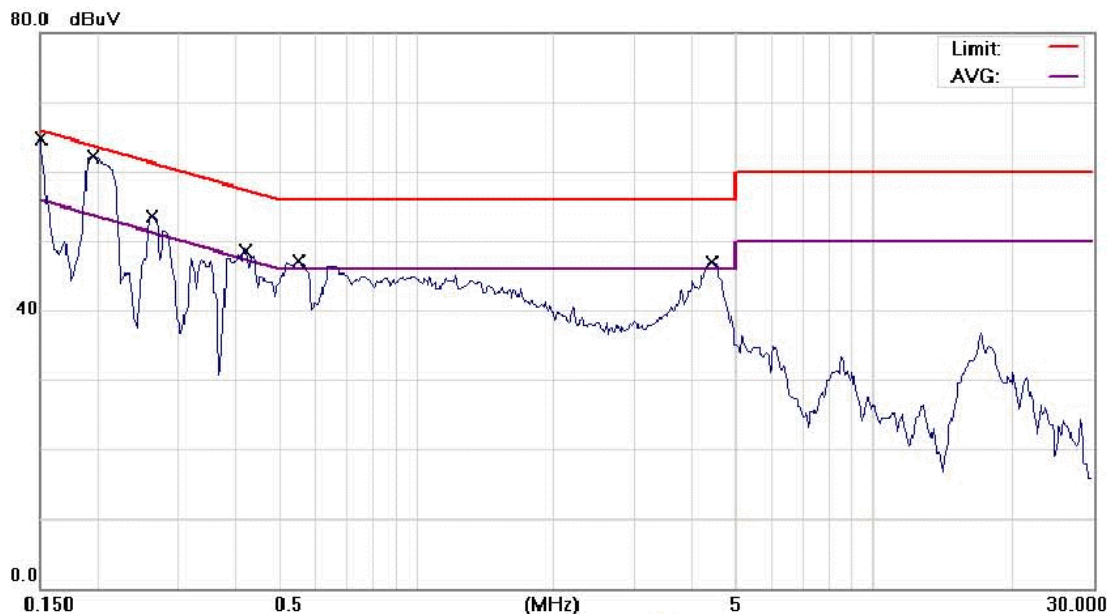

Site SGS CONDUCTED #1

Phase: **N**

Temperature: 23 °C

Limit: CISPR11 Class B Conduction(QP)

Power: AC 120V/60Hz

Humidity: 60 %

EUT: POS terminal

Distance:

Air Pressure: hpa

M/N: M81B

Note: NFC Operation mode

No.	Mk.	Freq.	Reading Level	Factor	Measurement	Limit	Over	Detector	Comment
		MHz	dBuV	dB	dBuV	dBuV	dB		
1		0.1500	56.50	0.20	56.70	66.00	-9.30	QP	
2		0.1500	40.10	0.20	40.30	56.00	-15.70	AVG	
3	*	0.1950	58.20	0.15	58.35	63.82	-5.47	QP	
4		0.1950	47.00	0.15	47.15	53.82	-6.67	AVG	
5		0.2650	48.70	0.13	48.83	61.27	-12.44	QP	
6		0.2650	31.00	0.13	31.13	51.27	-20.14	AVG	
7		0.4200	44.70	0.11	44.81	57.45	-12.64	QP	
8		0.4200	34.20	0.11	34.31	47.45	-13.14	AVG	
9		0.5500	42.80	0.10	42.90	56.00	-13.10	QP	
10		0.5500	30.70	0.10	30.80	46.00	-15.20	AVG	
11		4.4200	43.90	0.18	44.08	56.00	-11.92	QP	
12		4.4200	33.10	0.18	33.28	46.00	-12.72	AVG	

Unless otherwise stated the results shown in this test report refer only to the sample(s) tested and such sample(s) are retained for 90 days only. This test report cannot be reproduced, except in full, without prior written permission of the Company. 除非另有說明，此報告結果僅對測試之樣品負責，同時此樣品僅保留90天。本報告未經本公司書面許可，不可部份複製。

This document is issued by the Company subject to its General Conditions of Service ([www.sgs.com/terms\\_and\\_conditions.htm](http://www.sgs.com/terms_and_conditions.htm)) and Terms and Conditions for Electronic Documents ([www.sgs.com/terms\\_e-document.htm](http://www.sgs.com/terms_e-document.htm)). Attention is drawn to the limitations of liability, indemnification and jurisdictional issues established therein. Even if printed this electronic document is to be treated as an original within the meaning of UCP 600 article 20b. The authenticity of this document may be verified at [www.sgsonsite.com/authentication](http://www.sgsonsite.com/authentication). Any holder of this document is advised that information contained hereon reflects the Company's findings at the time of its intervention only and within the limits of client's instructions, if any. The Company's sole responsibility is to its Client and this document does not exonerate parties to a transaction from exercising all their rights and obligations under the transaction documents.



## 6 Radiated Emission Test

### 6.1 Measurement Procedure

1. The EUT was placed on a turn table which is 0.8m above ground plane.
2. Maximum procedure was performed on the six highest emissions to ensure EUT compliance.
3. And also, each emission was to be maximized by changing the polarization of receiving antenna both horizontal and vertical.
4. Repeat above procedures until all frequency measured were complete.

### 6.2 Test SET-UP (Block Diagram of Configuration)

(A) Radiated Emission Test Set-Up, Frequency Below 30MHz

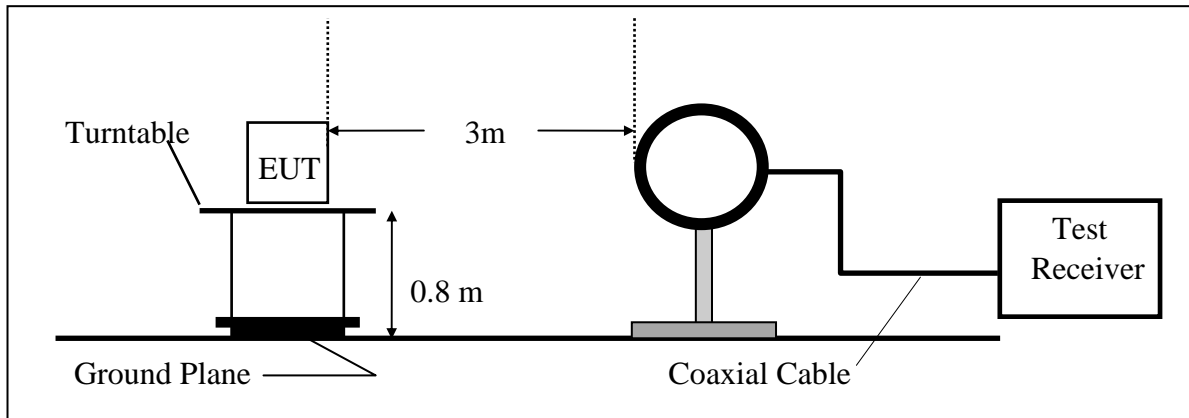

(B) Radiated Emission Test Set-Up, Frequency Below 1000MHz

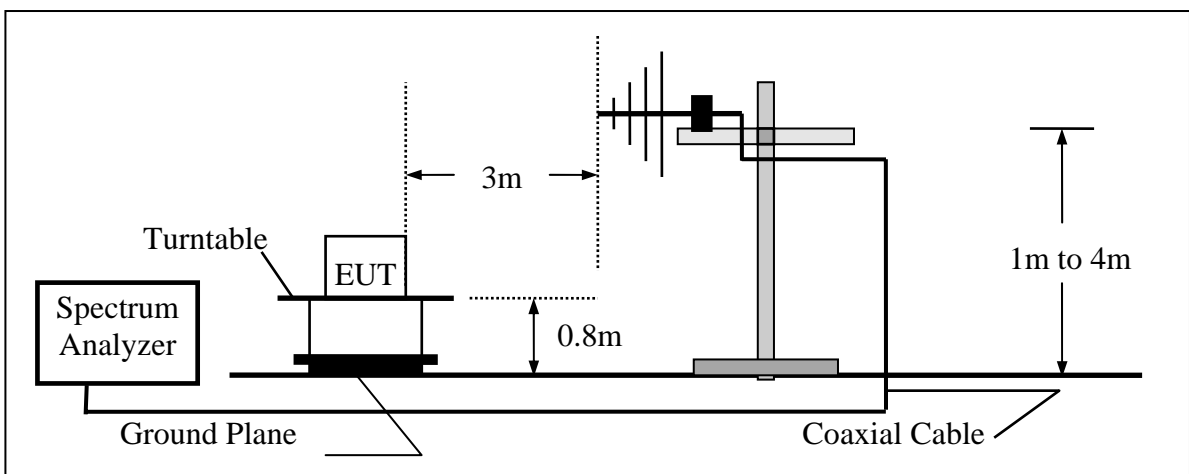

Unless otherwise stated the results shown in this test report refer only to the sample(s) tested and such sample(s) are retained for 90 days only. This test report cannot be reproduced, except in full, without prior written permission of the Company. 除非另有說明，此報告結果僅對測試之樣品負責，同時此樣品僅保留90天。本報告未經本公司書面許可，不可部份複製。  
This document is issued by the Company subject to its General Conditions of Service ([www.sgs.com/terms\\_and\\_conditions.htm](http://www.sgs.com/terms_and_conditions.htm)) and Terms and Conditions for Electronic Documents ([www.sgs.com/terms\\_e-document.htm](http://www.sgs.com/terms_e-document.htm)). Attention is drawn to the limitations of liability, indemnification and jurisdictional issues established therein. Even if printed this electronic document is to be treated as an original within the meaning of UCP 600 article 20b. The authenticity of this document may be verified at [www.sgsonsite.com/authentication](http://www.sgsonsite.com/authentication). Any holder of this document is advised that information contained hereon reflects the Company's findings at the time of its intervention only and within the limits of client's instructions, if any. The Company's sole responsibility is to its Client and this document does not exonerate parties to a transaction from exercising all their rights and obligations under the transaction documents.

### 6.3 Measurement Equipment Used:

966 Chamber					
EQUIPMENT TYPE	MFR	MODEL NUMBER	SERIAL NUMBER	LAST CAL.	CAL DUE.
Spectrum Analyzer	R&S	FSP 40	100034	02/22/2009	02/21/2010
Bilog Antenna	SCHWAZBECK	VULB9160	9160-3136	11/15/2009	11/14/2010
Loop antenna	MESSTEC	FLA30	03/10086	06/06/2009	06/05/2011
Pre-Amplifier	Agilent	8447D	1937A02834	11/30/2009	11/29/2010
Pre-Amplifier	Agilent	8449B	3008A01973	01/05/2009	01/04/2010
Turn Table	HD	DT420	N/A	N.C.R	N.C.R
Antenna Tower	HD	MA240-N	240/657	N.C.R	N.C.R
Controller	HD	HD100	N/A	N.C.R	N.C.R
Low Loss Cable	HUBER+SUHNER	SUCOFLEX 104PEA-10M	10m	01/05/2009	01/04/2010
Low Loss Cable	HUBER+SUHNER	SUCOFLEX 104PEA-3M	3m	01/05/2009	01/04/2010

### 6.4 Field Strength Calculation

The field strength is calculated by adding the Antenna Factor and Cable Factor and subtracting the Amplifier Gain and Duty Cycle Correction Factor (if any) from the measured reading. The basic equation with a sample calculation is as follows:

$$FS = RA + AF + CL - AG$$

Where	FS = Field Strength	CL = Cable Attenuation Factor (Cable Loss)
	RA = Reading Amplitude	AG = Amplifier Gain
	AF = Antenna Factor	

Unless otherwise stated the results shown in this test report refer only to the sample(s) tested and such sample(s) are retained for 90 days only. This test report cannot be reproduced, except in full, without prior written permission of the Company. 除非另有說明，此報告結果僅對測試之樣品負責，同時此樣品僅保留90天。本報告未經本公司書面許可，不可部份複製。

This document is issued by the Company subject to its General Conditions of Service ([www.sgs.com/terms\\_and\\_conditions.htm](http://www.sgs.com/terms_and_conditions.htm)) and Terms and Conditions for Electronic Documents ([www.sgs.com/terms\\_e-document.htm](http://www.sgs.com/terms_e-document.htm)). Attention is drawn to the limitations of liability, indemnification and jurisdictional issues established therein. Even if printed this electronic document is to be treated as an original within the meaning of UCP 600 article 20b. The authenticity of this document may be verified at [www.sgsonsite.com/authentication](http://www.sgsonsite.com/authentication). Any holder of this document is advised that information contained hereon reflects the Company's findings at the time of its intervention only and within the limits of client's instructions, if any. The Company's sole responsibility is to its Client and this document does not exonerate parties to a transaction from exercising all their rights and obligations under the transaction documents.

## 6.5 Measurement Result

Operation Mode: Transmitting Mode  
Fundamental Frequency: 13.56 MHz  
Temperature : 25 °C  
Humidity : 65 %

Test Date : Nov. 26, 2009  
Test By: Jazz  
Pol: Vertical

Freq. (MHz)	Ant.Pol. H/V	Detector Mode (PK/AV/QP)	Reading (dBuV)	Factor (dB)	Actual FS (dBuV/m)	Limit@3m (dBuV/m)	Safe Margin (dB)	Note
13.56	V	Peak	58.81	-5.30	53.51	123.99	-70.48	F
27.12	V	Peak	--					
40.68	V	Peak	--					
54.24	V	Peak	--					
67.80	V	Peak	--					
81.36	V	Peak	--					
94.92	V	Peak	--					
108.48	V	Peak	--					
122.04	V	Peak	--					
135.60	V	Peak	--					
172.59	V	Peak	45.10	-14.10	31.00	43.50	-12.50	E
223.03	V	Peak	48.67	-14.82	33.85	46.00	-12.15	E
264.74	V	Peak	45.54	-13.59	31.95	46.00	-14.05	E
281.23	V	Peak	44.89	-13.31	31.58	46.00	-14.42	E
390.84	V	Peak	39.66	-10.31	29.35	46.00	-16.65	E
482.99	V	Peak	37.78	-8.57	29.21	46.00	-16.79	E

### Remark :

- (1) Measuring frequencies from 25 MHz to the 1GHz.
- (2) Radiated emissions measured in frequency range from 25 MHz to 1000MHz were made with an instrument using Peak detector mode.
- (3) "F" denotes fundamental frequency; "H" denotes spurious frequency. "E" denotes band edge frequency.
- (4) Data of measurement within this frequency range shown "--" in the table above means the reading of emissions are attenuated more than 20dB below the permissible limits or the field strength is too small to be measured.
- (5) The IF bandwidth of SPA between 25MHz to 30MHz was 10KHz; 30MHz to 1GHz was 100KHz.

Unless otherwise stated the results shown in this test report refer only to the sample(s) tested and such sample(s) are retained for 90 days only. This test report cannot be reproduced, except in full, without prior written permission of the Company. 除非另有說明，此報告結果僅對測試之樣品負責，同時此樣品僅保留90天。本報告未經本公司書面許可，不可部份複製。

This document is issued by the Company subject to its General Conditions of Service ([www.sgs.com/terms\\_and\\_conditions.htm](http://www.sgs.com/terms_and_conditions.htm)) and Terms and Conditions for Electronic Documents ([www.sgs.com/terms\\_e-document.htm](http://www.sgs.com/terms_e-document.htm)). Attention is drawn to the limitations of liability, indemnification and jurisdictional issues established therein. Even if printed this electronic document is to be treated as an original within the meaning of UCP 600 article 20b. The authenticity of this document may be verified at [www.sgs.com/site/authentication](http://www.sgs.com/site/authentication). Any holder of this document is advised that information contained hereon reflects the Company's findings at the time of its intervention only and within the limits of client's instructions, if any. The Company's sole responsibility is to its Client and this document does not exonerate parties to a transaction from exercising all their rights and obligations under the transaction documents.

Operation Mode: Transmitting Mode  
Fundamental Frequency: 13.56 MHz  
Temperature : 25 °C  
Humidity : 65 %

Test Date : Nov. 26, 2009  
Test By: Jazz  
Pol: Horizontal

Freq. (MHz)	Ant.Pol. H/V	Detector Mode (PK/AV/QP)	Reading (dBuV)	Factor (dB)	Actual FS (dBuV/m)	Limit@3m (dBuV/m)	Safe Margin (dB)	Note
13.56	H	Peak	63.67	-5.30	58.37	123.99	-65.62	F
27.12	H	Peak	-					
40.68	H	Peak	-					
54.24	H	Peak	-					
67.80	H	Peak	-					
81.36	H	Peak	-					
94.92	H	Peak	-					
108.48	H	Peak	-					
122.04	H	Peak	-					
135.60	H	Peak	-					
46.49	H	Peak	48.11	-13.87	34.24	40.00	-5.76	E
193.93	H	Peak	55.92	-15.35	40.57	43.50	-2.93	E
223.03	H	Peak	51.13	-14.82	36.31	46.00	-9.69	E
390.84	H	Peak	43.52	-10.31	33.21	46.00	-12.79	E
489.78	H	Peak	41.60	-8.50	33.10	46.00	-12.90	E
649.83	H	Peak	38.22	-4.95	33.27	46.00	-12.73	E

Remark :

- (1) Measuring frequencies from 25 MHz to the 1GHz.
- (2) Radiated emissions measured in frequency range from 25 MHz to 1000MHz were made with an instrument using Peak detector mode.
- (3) "F" denotes fundamental frequency; "H" denotes spurious frequency. "E" denotes band edge frequency.
- (4) Data of measurement within this frequency range shown " - " in the table above means the reading of emissions are attenuated more than 20dB below the permissible limits or the field strength is too small to be measured.
- (5) The IF bandwidth of SPA between 25MHz to 30MHz was 10KHz; 30MHz to 1GHz was 100KHz.

Unless otherwise stated the results shown in this test report refer only to the sample(s) tested and such sample(s) are retained for 90 days only. This test report cannot be reproduced, except in full, without prior written permission of the Company. 除非另有說明，此報告結果僅對測試之樣品負責，同時此樣品僅保留90天。本報告未經本公司書面許可，不可部份複製。

This document is issued by the Company subject to its General Conditions of Service ([www.sgs.com/terms\\_and\\_conditions.htm](http://www.sgs.com/terms_and_conditions.htm)) and Terms and Conditions for Electronic Documents ([www.sgs.com/terms\\_e-document.htm](http://www.sgs.com/terms_e-document.htm)). Attention is drawn to the limitations of liability, indemnification and jurisdictional issues established therein. Even if printed this electronic document is to be treated as an original within the meaning of UCP 600 article 20b. The authenticity of this document may be verified at [www.sgsonsite.com/authentication](http://www.sgsonsite.com/authentication). Any holder of this document is advised that information contained hereon reflects the Company's findings at the time of its intervention only and within the limits of client's instructions, if any. The Company's sole responsibility is to its Client and this document does not exonerate parties to a transaction from exercising all their rights and obligations under the transaction documents.

Operation Mode: RX Mode  
Fundamental Frequency: 13.56 MHz  
Temperature : 25 °C  
Humidity : 65 %

Test Date : Nov. 26, 2009  
Test By: Jazz  
Pol: Vertical

Freq. (MHz)	Ant.Pol. H/V	Detector Mode (PK/AV/QP)	Reading (dBuV)	Factor (dB)	Actual FS (dBuV/m)	Limit@3m (dBuV/m)	Safe Margin (dB)	Note
193.93	V	Peak	55.80	-15.35	40.45	43.50	-3.05	E
223.03	V	Peak	52.49	-14.82	37.67	46.00	-8.33	E
281.23	V	Peak	48.24	-13.31	34.93	46.00	-11.07	E
327.79	V	Peak	44.85	-12.36	32.49	46.00	-13.51	E
460.68	V	Peak	41.14	-8.61	32.53	46.00	-13.47	E

Remark :

- (1) Measuring frequencies from 25 MHz to the 1GHz.
- (2) Radiated emissions measured in frequency range from 25 MHz to 1000MHz were made with an instrument using Peak detector mode.
- (3) "F" denotes fundamental frequency; "H" denotes spurious frequency. "E" denotes band edge frequency.
- (4) Data of measurement within this frequency range shown " - " in the table above means the reading of emissions are attenuated more than 20dB below the permissible limits or the field strength is too small to be measured.
- (5) The IF bandwidth of SPA between 25MHz to 30MHz was 10KHz; 30MHz to 1GHz was 100KHz.

Unless otherwise stated the results shown in this test report refer only to the sample(s) tested and such sample(s) are retained for 90 days only. This test report cannot be reproduced, except in full, without prior written permission of the Company. 除非另有說明，此報告結果僅對測試之樣品負責，同時此樣品僅保留90天。本報告未經本公司書面許可，不可部份複製。

This document is issued by the Company subject to its General Conditions of Service ([www.sgs.com/terms\\_and\\_conditions.htm](http://www.sgs.com/terms_and_conditions.htm)) and Terms and Conditions for Electronic Documents ([www.sgs.com/terms\\_e-document.htm](http://www.sgs.com/terms_e-document.htm)). Attention is drawn to the limitations of liability, indemnification and jurisdictional issues established therein. Even if printed this electronic document is to be treated as an original within the meaning of UCP 600 article 20b. The authenticity of this document may be verified at [www.sgsonsite.com/authentication](http://www.sgsonsite.com/authentication). Any holder of this document is advised that information contained hereon reflects the Company's findings at the time of its intervention only and within the limits of client's instructions, if any. The Company's sole responsibility is to its Client and this document does not exonerate parties to a transaction from exercising all their rights and obligations under the transaction documents.

Operation Mode: RX Mode  
Fundamental Frequency: 13.56 MHz  
Temperature : 25 °C  
Humidity : 65 %

Test Date : Nov. 26, 2009  
Test By: Jazz  
Pol: Horizontal

Freq. (MHz)	Ant.Pol. H/V	Detector Mode (PK/AV/QP)	Reading (dBuV)	Factor (dB)	Actual FS (dBuV/m)	Limit@3m (dBuV/m)	Safe Margin (dB)	Note
162.89	H	Peak	46.27	-13.57	32.70	43.50	-10.80	E
252.13	H	Peak	43.84	-13.72	30.12	46.00	-15.88	E
342.34	H	Peak	42.64	-11.97	30.67	46.00	-15.33	E
371.44	H	Peak	39.47	-11.02	28.45	46.00	-17.55	E
460.68	H	Peak	36.02	-8.61	27.41	46.00	-18.59	E
596.48	H	Peak	34.30	-6.12	28.18	46.00	-17.82	E

Remark :

- (1) Measuring frequencies from 25 MHz to the 1GHz.
- (2) Radiated emissions measured in frequency range from 25 MHz to 1000MHz were made with an instrument using Peak detector mode.
- (3) "F" denotes fundamental frequency; "H" denotes spurious frequency. "E" denotes band edge frequency.
- (4) Data of measurement within this frequency range shown " - " in the table above means the reading of emissions are attenuated more than 20dB below the permissible limits or the field strength is too small to be measured.
- (5) The IF bandwidth of SPA between 25MHz to 30MHz was 10KHz; 30MHz to 1GHz was 100KHz.

Unless otherwise stated the results shown in this test report refer only to the sample(s) tested and such sample(s) are retained for 90 days only. This test report cannot be reproduced, except in full, without prior written permission of the Company. 除非另有說明，此報告結果僅對測試之樣品負責，同時此樣品僅保留90天。本報告未經本公司書面許可，不可部份複製。

This document is issued by the Company subject to its General Conditions of Service ([www.sgs.com/terms\\_and\\_conditions.htm](http://www.sgs.com/terms_and_conditions.htm)) and Terms and Conditions for Electronic Documents ([www.sgs.com/terms\\_e-document.htm](http://www.sgs.com/terms_e-document.htm)). Attention is drawn to the limitations of liability, indemnification and jurisdictional issues established therein. Even if printed this electronic document is to be treated as an original within the meaning of UCP 600 article 20b. The authenticity of this document may be verified at [www.sgs.com/site/authentication](http://www.sgs.com/site/authentication). Any holder of this document is advised that information contained hereon reflects the Company's findings at the time of its intervention only and within the limits of client's instructions, if any. The Company's sole responsibility is to its Client and this document does not exonerate parties to a transaction from exercising all their rights and obligations under the transaction documents.

### Radiated Mask

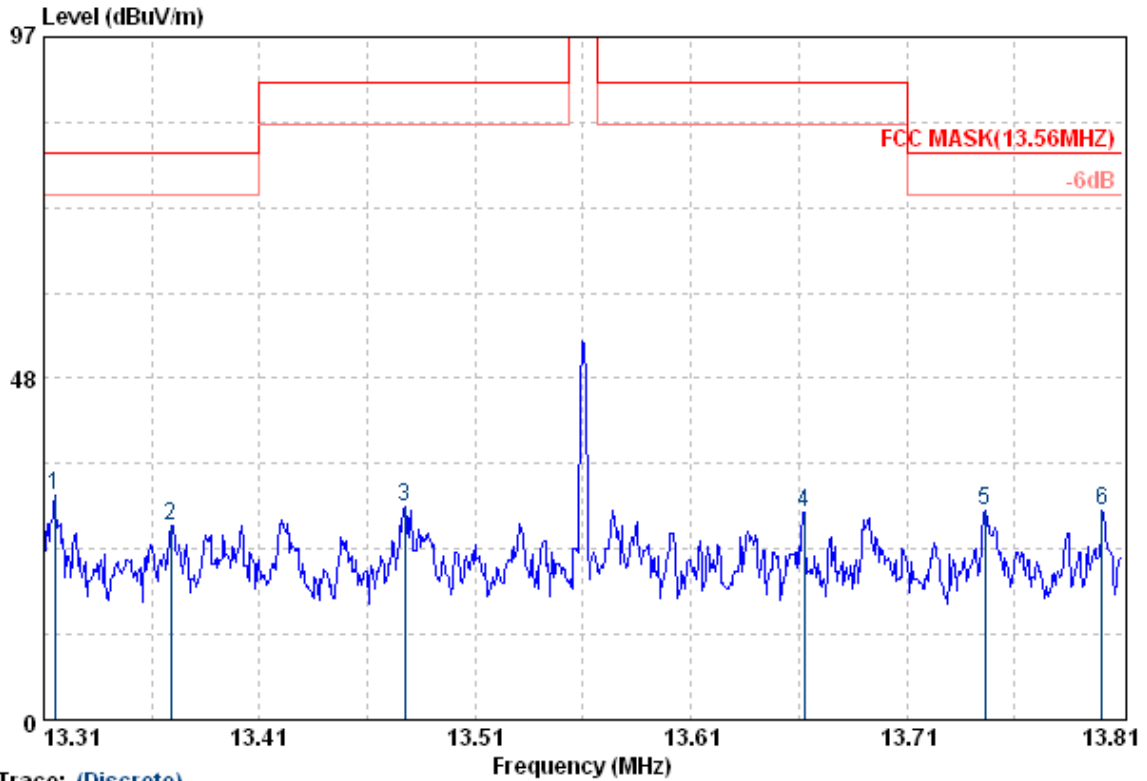

Trace: (Discrete)

Site : RF Site  
 Condition : FCC MASK(13.56MHz) 3m FLA30 VERTICAL  
 Project No. : EH-2009-30020  
 Applicant : 英華達  
 EUT Description : POS terminal  
 EUT Model : M81B  
 Test Mode : TX MODE /e1 PLAN  
 Temp./Humid. : AC Adapter:IU18-2050200-WP  
 Operator : Earphone:N/A  
 : USB Cable:N/A  
 : 25 deg. C/65 RH  
 : JAZZ

	Freq	Read Level	Antenna Factor	Cable Loss	Factor	Level	Limit Line	Over Limit	Remark
	MHz	dBuV	dB/m	dB	dB/m	dBuV/m	dBuV/m	dB	
1 @	13.32	37.25	22.70	0.38	-5.44	31.81	80.50	-48.69	Peak
2	13.37	32.94	22.73	0.38	-5.41	27.53	80.50	-52.97	Peak
3	13.48	35.63	22.78	0.38	-5.35	30.28	90.47	-60.19	Peak
4	13.66	34.70	22.88	0.39	-5.23	29.47	90.47	-61.00	Peak
5	13.75	34.84	22.91	0.39	-5.19	29.65	80.50	-50.85	Peak
6	13.80	34.93	22.94	0.39	-5.16	29.77	80.50	-50.73	Peak

Unless otherwise stated the results shown in this test report refer only to the sample(s) tested and such sample(s) are retained for 90 days only. This test report cannot be reproduced, except in full, without prior written permission of the Company. 除非另有說明，此報告結果僅對測試之樣品負責，同時此樣品僅保留90天。本報告未經本公司書面許可，不可部份複製。  
 This document is issued by the Company subject to its General Conditions of Service ([www.sgs.com/terms\\_and\\_conditions.htm](http://www.sgs.com/terms_and_conditions.htm)) and Terms and Conditions for Electronic Documents ([www.sgs.com/terms\\_e-document.htm](http://www.sgs.com/terms_e-document.htm)). Attention is drawn to the limitations of liability, indemnification and jurisdictional issues established therein. Even if printed this electronic document is to be treated as an original within the meaning of UCP 600 article 20b. The authenticity of this document may be verified at [www.sgsonsite.com/authentication](http://www.sgsonsite.com/authentication). Any holder of this document is advised that information contained herein reflects the Company's findings at the time of its intervention only and within the limits of client's instructions, if any. The Company's sole responsibility is to its Client and this document does not exonerate parties to a transaction from exercising all their rights and obligations under the transaction documents.

## Radiated Mask

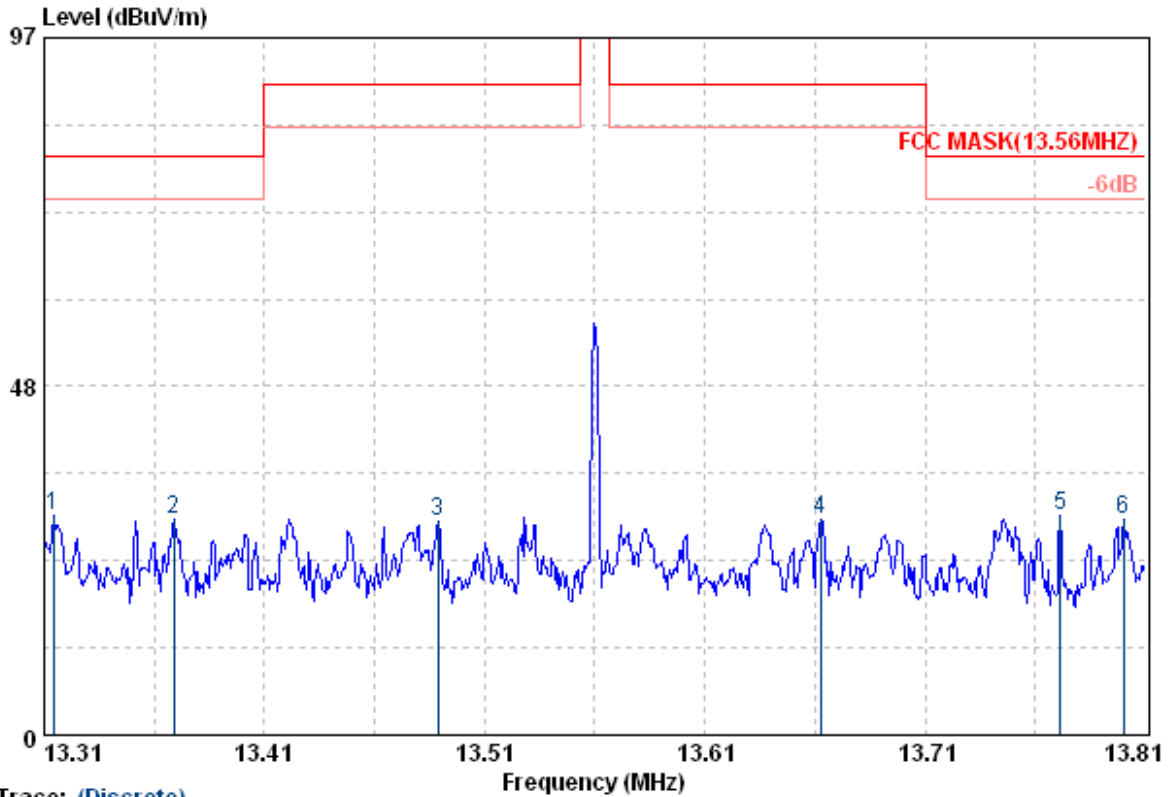

Trace: (Discrete)

Site : RF Site  
 Condition : FCC MASK(13.56MHz) 3m FLA30 HORIZONTAL  
 Project No. : EH-2009-30020  
 Applicant : 英華達  
 EUT Description : POS terminal  
 EUT Model : M81B  
 Test Mode : TX MODE /e1 PLAN  
 Temp./Humid. : AC Adapter:IU18-2050200-WP  
 Operator : Earphone:N/A  
           : USB Cable:N/A  
           : 25 deg. C/65 RH  
           : JAZZ

	Freq	Read Level	Antenna Factor	Cable Loss	Factor	Level	Limit	Over	Remark
	MHz	dBuV	dB/m	dB	dB/m	dBuV/m	dBuV/m	dB	
1 @	13.31	35.84	22.70	0.38	-5.44	30.40	80.50	-50.10	Peak
2	13.37	35.39	22.73	0.38	-5.41	29.98	80.50	-50.52	Peak
3	13.49	35.00	22.79	0.38	-5.34	29.66	90.47	-60.81	Peak
4	13.66	35.10	22.88	0.39	-5.23	29.87	90.47	-60.60	Peak
5	13.77	35.77	22.93	0.39	-5.17	30.60	80.50	-49.90	Peak
6	13.80	35.08	22.94	0.39	-5.16	29.92	80.50	-50.58	Peak

Unless otherwise stated the results shown in this test report refer only to the sample(s) tested and such sample(s) are retained for 90 days only. This test report cannot be reproduced, except in full, without prior written permission of the Company. 除非另有說明，此報告結果僅對測試之樣品負責，同時此樣品僅保留90天。本報告未經本公司書面許可，不可部份複製。

This document is issued by the Company subject to its General Conditions of Service ([www.sgs.com/terms\\_and\\_conditions.htm](http://www.sgs.com/terms_and_conditions.htm)) and Terms and Conditions for Electronic Documents ([www.sgs.com/terms\\_e-document.htm](http://www.sgs.com/terms_e-document.htm)). Attention is drawn to the limitations of liability, indemnification and jurisdictional issues established therein. Even if printed this electronic document is to be treated as an original within the meaning of UCP 600 article 20b. The authenticity of this document may be verified at [www.sgsonsite.com/authentication](http://www.sgsonsite.com/authentication). Any holder of this document is advised that information contained hereon reflects the Company's findings at the time of its intervention only and within the limits of client's instructions, if any. The Company's sole responsibility is to its Client and this document does not exonerate parties to a transaction from exercising all their rights and obligations under the transaction documents.



## 7 Frequency Tolerance

### 7.1 Measurement Procedure

1. The EUT was placed on a turn table which is 0.8m above ground plane.
2. Set EUT as normal operation
3. Set SPA Center Frequency = fundamental frequency, RBW, VBW= 1K, Span =30K.
4. Set SPA Max hold. Mark peak, -26dB.

### 7.2 Test SET-UP (Block Diagram of Configuration)

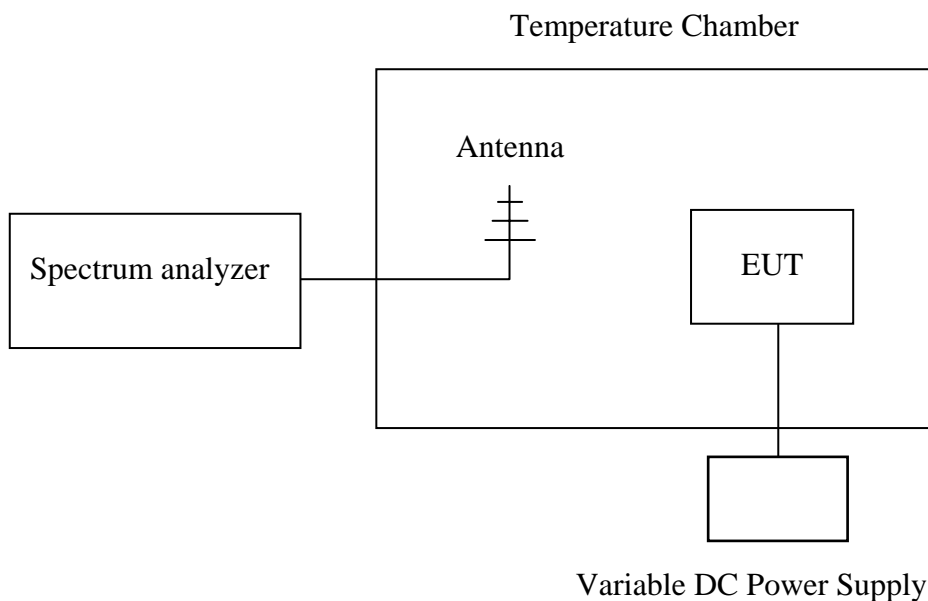

### 7.3 Measurement Equipment Used:

Same as 6.2 Radiated Emission Measurement.

### 7.4 Measurement Results

Refer to attached data chart.

Unless otherwise stated the results shown in this test report refer only to the sample(s) tested and such sample(s) are retained for 90 days only. This test report cannot be reproduced, except in full, without prior written permission of the Company. 除非另有說明，此報告結果僅對測試之樣品負責，同時此樣品僅保留90天。本報告未經本公司書面許可，不可部份複製。

This document is issued by the Company subject to its General Conditions of Service ([www.sgs.com/terms\\_and\\_conditions.htm](http://www.sgs.com/terms_and_conditions.htm)) and Terms and Conditions for Electronic Documents ([www.sgs.com/terms\\_e-document.htm](http://www.sgs.com/terms_e-document.htm)). Attention is drawn to the limitations of liability, indemnification and jurisdictional issues established therein. Even if printed this electronic document is to be treated as an original within the meaning of UCP 600 article 20b. The authenticity of this document may be verified at [www.sgsonsite.com/authentication](http://www.sgsonsite.com/authentication). Any holder of this document is advised that information contained hereon reflects the Company's findings at the time of its intervention only and within the limits of client's instructions, if any. The Company's sole responsibility is to its Client and this document does not exonerate parties to a transaction from exercising all their rights and obligations under the transaction documents.

### A. Temperature Variation

Power Supply	Environment	Frequency	Delta (Hz)	Limit (KHz)
Vdc	Temperature (°C)	(MHz)		
3.6	-20	13.560317	-67.00	+/- 1.356
3.6	-10	13.5603	-50.00	+/- 1.356
3.6	0	13.5603	-50.00	+/- 1.356
3.6	10	13.56025	0.00	+/- 1.356
3.6	20	13.56025	0.00	+/- 1.356
3.6	30	13.560243	7.00	+/- 1.356

### B. Supply Voltage Variation

Power Supply	Environment	Frequency	Delta (Hz)	Limit (KHz)
Vdc	Temperature (°C)	(MHz)		
4.2	20	13.560281	-31.00	+/- 1.356
3.6	20	13.56025	0.00	+/- 1.356
3.5	20	13.560261	-11.00	+/- 1.356

Unless otherwise stated the results shown in this test report refer only to the sample(s) tested and such sample(s) are retained for 90 days only. This test report cannot be reproduced, except in full, without prior written permission of the Company. 除非另有說明，此報告結果僅對測試之樣品負責，同時此樣品僅保留90天。本報告未經本公司書面許可，不可部份複製。

This document is issued by the Company subject to its General Conditions of Service ([www.sgs.com/terms\\_and\\_conditions.htm](http://www.sgs.com/terms_and_conditions.htm)) and Terms and Conditions for Electronic Documents ([www.sgs.com/terms\\_e-document.htm](http://www.sgs.com/terms_e-document.htm)). Attention is drawn to the limitations of liability, indemnification and jurisdictional issues established therein. Even if printed this electronic document is to be treated as an original within the meaning of UCP 600 article 20b. The authenticity of this document may be verified at [www.sgsonsite.com/authentication](http://www.sgsonsite.com/authentication). Any holder of this document is advised that information contained hereon reflects the Company's findings at the time of its intervention only and within the limits of client's instructions, if any. The Company's sole responsibility is to its Client and this document does not exonerate parties to a transaction from exercising all their rights and obligations under the transaction documents.

## 8. 99% OCCUPIED BANDWIDTH MEASUREMENT

### 8.1 Test Set-up:

Refer to section 6.2 in this report

### 8.2 Measurement Procedure:

The EUT's output RF connector was connected with a short cable to the spectrum analyzer, RBW (10KHz) was set to about 1% of emission BW, VBW= 3 times RBW(10KHz), -26dBc display line was placed on the screen (or 99% bandwidth), the occupied bandwidth is the delta frequency between the two points where the display line intersects the signal trace.

### 8.3 Measurement Equipment Used:

Refer to section 6.3 in this report

