

TEST REPORT

BNetzA-CAB-02/21-102

Test report no.: 1-8503/19-01-09

Testing laboratory

CTC advanced GmbH

Untertuerkheimer Strasse 6 – 10
66117 Saarbruecken / Germany

Phone: + 49 681 5 98 - 0

Fax: + 49 681 5 98 - 9075

Internet: <http://www.ctcadvanced.com>

e-mail: mail@ctcadvanced.com

Accredited Testing Laboratory:

The testing laboratory (area of testing) is accredited according to DIN EN ISO/IEC 17025 (2005) by the Deutsche Akkreditierungsstelle GmbH (DAkkS)

The accreditation is valid for the scope of testing procedures as stated in the accreditation certificate starting with the registration number: D-PL-12076-01.

Applicant

Ingenico Group

9 Avenue de la Gare Rovaltain
26958 Valence Cedex 9 / FRANCE

Phone: -/-

Contact: Nicolas Jacquemont

e-mail: nicolas.jacquemont@ingenico.com

Phone: +33475842123

Manufacturer

Ingenico Group

9 Avenue de la Gare Rovaltain
26958 Valence Cedex 9 / FRANCE

Test standard/s

FCC - Title 47 CFR Part 15 FCC - Title 47 of the Code of Federal Regulations; Chapter I; Part 15 - Radio frequency devices

RSS - 247 Issue 2 Digital Transmission Systems (DTSs), Frequency Hopping Systems (FHSs) and Licence - Exempt Local Area Network (LE-LAN) Devices

For further applied test standards please refer to section 3 of this test report.

Test Item

Kind of test item: **Communication dongle**

Model name: **XTRA module**

FCC ID: **XKB-XTRAWIBTC**

IC: **2586D-XTRAWIBTC**

Frequency: UNII band: 5470 MHz to 5725 MHz

Technology tested: WLAN

Antenna: Integrated FLEX antenna

Power supply: 110 V AC & 5 V DC by mains adapter / battery

Temperature range: 0°C to +40°C

This test report is electronically signed and valid without handwritten signature. For verification of the electronic signatures, the public keys can be requested at the testing laboratory.

Test report authorized:

Andreas Luckenbill
Lab Manager
Radio Communications & EMC

Test performed:

Mihail Dorongovskij
Lab Manager
Radio Communications & EMC

1 Table of contents

1	Table of contents	2
2	General information	4
2.1	Notes and disclaimer	4
2.2	Application details	4
2.3	Test laboratories sub-contracted	4
3	Test standard/s, references and accreditations	5
4	Test environment	6
5	Test item	6
5.1	General description	6
5.2	Additional information	7
6	Description of the test setup.....	8
6.1	Shielded semi anechoic chamber	9
6.2	Shielded fully anechoic chamber.....	10
6.3	Radiated measurements > 18 GHz.....	12
6.4	Conducted measurements	13
6.5	AC conducted	14
7	Measurement uncertainty	15
8	Sequence of testing	16
8.1	Sequence of testing radiated spurious 9 kHz to 30 MHz	16
8.2	Sequence of testing radiated spurious 30 MHz to 1 GHz	17
8.3	Sequence of testing radiated spurious 1 GHz to 18 GHz	18
8.4	Sequence of testing radiated spurious above 18 GHz	19
9	Summary of measurement results	20
10	Additional comments	21
11	Measurement results	23
11.1	Identify worst case data rate	23
11.2	Antenna gain.....	24
11.3	Duty cycle	25
11.4	Maximum output power.....	26
11.4.1	Maximum output power according to FCC requirements	26
11.4.2	Maximum output power according to IC requirements	28
11.5	Power spectral density	30
11.5.1	Power spectral density according to FCC requirements.....	30
11.5.2	Power spectral density according to IC requirements	32
11.6	Spectrum bandwidth / 26 dB bandwidth.....	34
11.7	Occupied bandwidth / 99% emission bandwidth	36
11.8	Band edge compliance radiated	38
11.9	Spurious emissions radiated below 30 MHz.....	40
11.10	Spurious emissions radiated 30 MHz to 1 GHz	45
11.11	Spurious emissions radiated 1 GHz to 40 GHz	52
11.12	Spurious emissions conducted < 30 MHz.....	64

Annex A	Glossary.....	67
Annex B	Document history	68
Annex C	Accreditation Certificate – D-PL-12076-01-04.....	68
Annex D	Accreditation Certificate – D-PL-12076-01-05.....	69

2 General information

2.1 Notes and disclaimer

The test results of this test report relate exclusively to the test item specified in this test report. CTC advanced GmbH does not assume responsibility for any conclusions and generalizations drawn from the test results with regard to other specimens or samples of the type of the equipment represented by the test item.

The test report may only be reproduced or published in full. Reproduction or publication of extracts from the report requires the prior written approval of CTC advanced GmbH.

The testing service provided by CTC advanced GmbH has been rendered under the current "General Terms and Conditions for CTC advanced GmbH".

CTC advanced GmbH will not be liable for any loss or damage resulting from false, inaccurate, inappropriate or incomplete product information provided by the customer.

Under no circumstances does the CTC advanced GmbH test report include any endorsement or warranty regarding the functionality, quality or performance of any other product or service provided.

Under no circumstances does the CTC advanced GmbH test report include or imply any product or service warranties from CTC advanced GmbH, including, without limitation, any implied warranties of merchantability, fitness for purpose, or non-infringement, all of which are expressly disclaimed by CTC advanced GmbH.

All rights and remedies regarding vendor's products and services for which CTC advanced GmbH has prepared this test report shall be provided by the party offering such products or services and not by CTC advanced GmbH. In no case this test report can be considered as a Letter of Approval.

This test report is electronically signed and valid without handwritten signature. For verification of the electronic signatures, the public keys can be requested at the testing laboratory.

2.2 Application details

Date of receipt of order:	2019-08-26
Date of receipt of test item:	2019-08-27
Start of test:	2019-11-22
End of test:	2019-12-04
Person(s) present during the test:	-/-

2.3 Test laboratories sub-contracted

None

3 Test standard/s, references and accreditations

Test standard	Date	Description
FCC - Title 47 CFR Part 15		FCC - Title 47 of the Code of Federal Regulations; Chapter I; Part 15 - Radio frequency devices
RSS - 247 Issue 2	February 2017	Digital Transmission Systems (DTSs), Frequency Hopping Systems (FHSs) and Licence - Exempt Local Area Network (LE-LAN) Devices
RSS - Gen Issue 5	April 2018	Spectrum Management and Telecommunications Radio Standards Specification - General Requirements for Compliance of Radio Apparatus

Guidance	Version	Description
KDB 789033 D02	v02r01	Guidelines for Compliance Testing of Unlicensed National Information Infrastructure (U-NII) Devices - Part 15, Subpart E
ANSI C63.4-2014	-/-	American National Standard for Methods of Measurement of Radio-Noise Emissions from Low-Voltage Electrical and Electronic Equipment in the Range of 9 kHz to 40 GHz
ANSI C63.10-2013	-/-	American National Standard of Procedures for Compliance Testing of Unlicensed Wireless Devices

Accreditation	Description	
D-PL-12076-01-04	Telecommunication and EMC Canada https://www.dakks.de/as/ast/d/D-PL-12076-01-04.pdf	  Deutsche Akkreditierungsstelle D-PL-12076-01-04
D-PL-12076-01-05	Telecommunication FCC requirements https://www.dakks.de/as/ast/d/D-PL-12076-01-05.pdf	  Deutsche Akkreditierungsstelle D-PL-12076-01-05

4 Test environment

Temperature	:	T_{nom} T_{max} T_{min}	+22 °C during room temperature tests No tests under extreme temperature conditions required. No tests under extreme temperature conditions required.
Relative humidity content	:		55 %
Barometric pressure	:		1021 hpa
Power supply	:	V_{nom} V_{max} V_{min}	110 V AC & 5 V DC by mains adapter / battery No tests under extreme voltage conditions required. No tests under extreme voltage conditions required.

5 Test item

5.1 General description

Kind of test item	:	Communication dongle
Model name	:	XTRA module
HMN	:	Lane/7000 Lane/8000
PMN	:	XTRA module
HVIN	:	MODU/7005 WiFi/BT MODU/8005 WiFi/BT MODU/7003 WiFi/BT
FVIN	:	n/a
S/N serial number	:	Rad. Host LANE7000: Module: 183132213091023807491902 Host: 190682203011067808006807 Host LANE8000: Module: 182322213091023807362912 Host: 191072213011040108138482 Stand-alone configuration: Module: 182322213091023807362912 Cond. Module: 190682203011067808006807
Hardware status	:	OS_045400
Software status	:	HTB_0202
Firmware status	:	n/a
Frequency band	:	UNII band: 5470 MHz to 5725 MHz
Type of radio transmission	:	OFDM
Use of frequency spectrum	:	
Type of modulation	:	BPSK, QPSK, 16 – QAM, 64 – QAM
Number of channels	:	20 MHz channels: 11 40 MHz channels: 5
Antenna	:	Integrated FLEX antenna
Power supply	:	110 V AC & 5 V DC by mains adapter / battery
Temperature range	:	0°C to +40°C

5.2 Additional information

Test setup and EUT photos are included in test report:

- 1-8503/19-01-01_AnnexA
- 1-8503/19-01-01_AnnexB
- 1-8503/19-01-01_AnnexD

6 Description of the test setup

Typically, the calibrations of the test apparatus are commissioned to and performed by an accredited calibration laboratory. The calibration intervals are determined in accordance with the DIN EN ISO/IEC 17025. In addition to the external calibrations, the laboratory executes comparison measurements with other calibrated test systems or effective verifications. Weekly chamber inspections and range calibrations are performed. Where possible, RF generating and signaling equipment as well as measuring receivers and analyzers are connected to an external high-precision 10 MHz reference (GPS-based or rubidium frequency standard).

In order to simplify the identification of the equipment used at some special tests, some items of test equipment and ancillaries can be provided with an identifier or number in the equipment list below (Lab/Item).

Agenda: Kind of Calibration

k	calibration / calibrated	EK	limited calibration
ne	not required (k, ev, izw, zw not required)	zw	cyclical maintenance (external cyclical maintenance)
ev	periodic self verification	izw	internal cyclical maintenance
Ve	long-term stability recognized	g	blocked for accredited testing
vlk!	Attention: extended calibration interval		
NK!	Attention: not calibrated	*)	next calibration ordered / currently in progress

6.1 Shielded semi anechoic chamber

The radiated measurements are performed in vertical and horizontal plane in the frequency range from 30 MHz to 1 GHz in semi-anechoic chambers. The EUT is positioned on a non-conductive support with a height of 0.80 m above a conductive ground plane that covers the whole chamber. The receiving antennas are conform to specifications ANSI C63. These antennas can be moved over the height range between 1.0 m and 4.0 m in order to search for maximum field strength emitted from EUT. The measurement distances between EUT and receiving antennas are indicated in the test setups for the various frequency ranges. For each measurement, the EUT is rotated in all three axes until the maximum field strength is received. The wanted and unwanted emissions are received by spectrum analyzers where the detector modes and resolution bandwidths over various frequency ranges are set according to requirement ANSI C63.

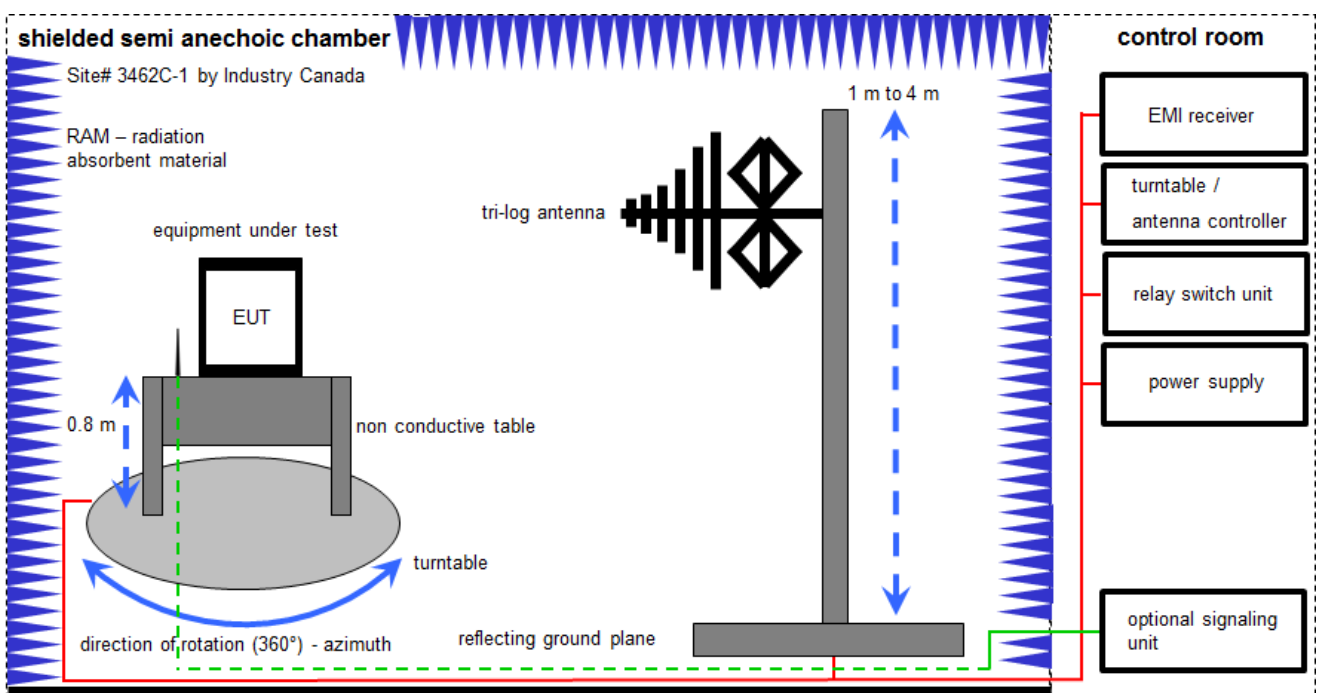

Measurement distance: tri-log antenna 10 meter

$$FS = UR + CL + AF$$

(FS-field strength; UR-voltage at the receiver; CL-loss of the cable; AF-antenna factor)

Example calculation:

$$FS [dB\mu V/m] = 12.35 [dB\mu V/m] + 1.90 [dB] + 16.80 [dB/m] = 31.05 [dB\mu V/m] (35.69 \mu V/m)$$

Equipment table:

No.	Lab / Item	Equipment	Type	Manufacturer	Serial No.	INV. No.	Kind of Calibration	Last Calibration	Next Calibration
1	A	Switch-Unit	3488A	HP	2719A14505	300000368	ev	-/-	-/-
2	A	Meßkabine 1	HF-Absorberhalle	MWB AG 300023	-/-	300000551	ne	-/-	-/-
3	A	Antenna Tower	Model 2175	ETS-Lindgren	64762	300003745	izw	-/-	-/-
4	A	Positioning Controller	Model 2090	ETS-Lindgren	64672	300003746	izw	-/-	-/-
5	A	Turntable Interface-Box	Model 105637	ETS-Lindgren	44583	300003747	izw	-/-	-/-
6	A	TRILOG Broadband Test-Antenna 30 MHz - 3 GHz	VULB9163	Schwarzbeck Mess-Elektronik	295	300003787	vKI!	19.02.2019	18.02.2021
7	A	EMI Test Receiver	ESR3	Rohde & Schwarz	102587	300005771	k	21.05.2019	20.05.2020

6.2 Shielded fully anechoic chamber

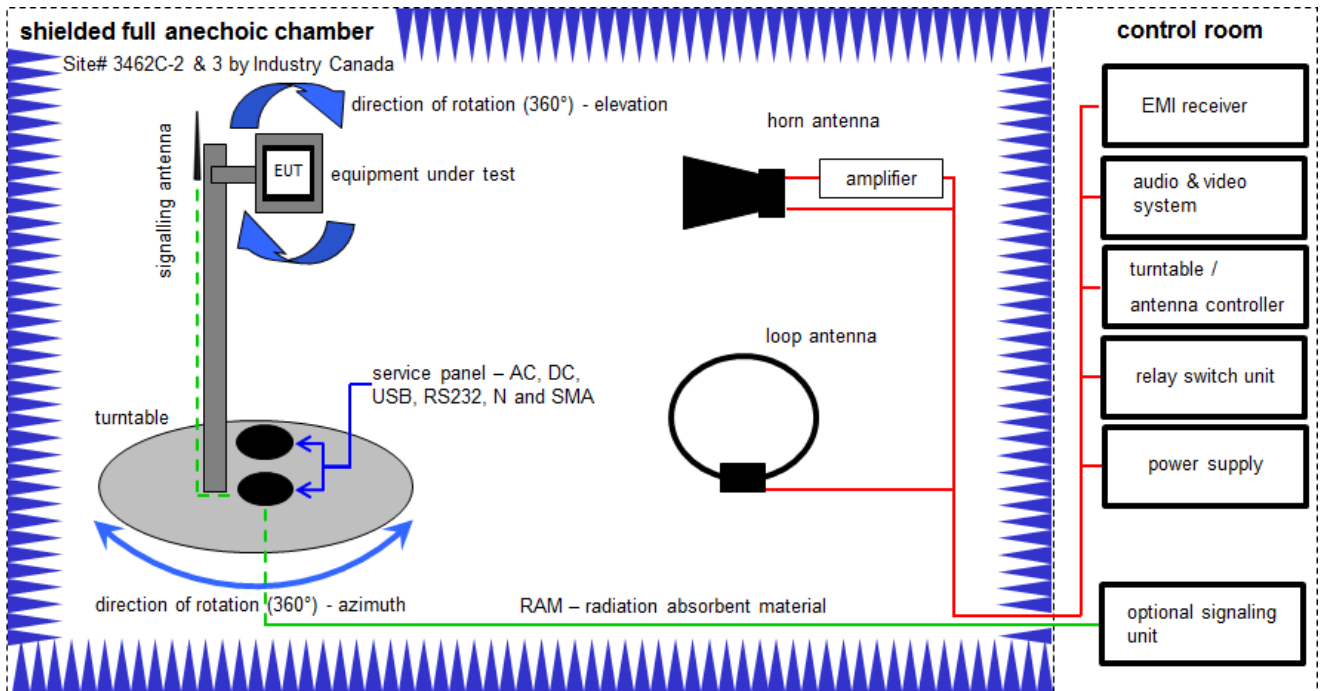

Measurement distance: horn antenna 3 meter; loop antenna 3 meter

FS = UR + CA + AF

(FS-field strength; UR-voltage at the receiver; CA-loss of the signal path; AF-antenna factor)

Example calculation:

FS [dBµV/m] = 40.0 [dBµV/m] + (-35.8) [dB] + 32.9 [dB/m] = 37.1 [dBµV/m] (71.61 µV/m)

Equipment table:

No.	Lab / Item	Equipment	Type	Manufacturer	Serial No.	INV. No.	Kind of Calibration	Last Calibration	Next Calibration
1	A	Active Loop Antenna 9 kHz to 30 MHz	6502	EMCO	2210	300001015	vKI!	13.06.2019	12.06.2021
2	B, C	Double-Ridged Waveguide Horn Antenna 1-18.0GHz	3115	EMCO	9107-3696	300001604	vKI!	27.02.2019	26.02.2021
3	C	Highpass Filter	WHKX7.0/18G-8SS	Wainwright	18	300003789	ne	-/-	-/-
4	B, C	Broadband Amplifier 0.5-18 GHz	CBLU5184540	CERNEX	22051	300004483	ev	-/-	-/-
5	A, B, C	4U RF Switch Platform	L4491A	Agilent Technologies	MY50000032	300004510	ne	-/-	-/-
6	A, B, C	NEXIO EMV-Software	BAT EMC V3.19.1.9	EMCO	-/-	300004682	ne	-/-	-/-
7	A, B, C	Anechoic chamber	-/-	TDK	-/-	300003726	ne	-/-	-/-
8	C	Band Reject Filter	WRCJV12-5120-5150-5350-5380-40SS	Wainwright	5	300005168	ev	-/-	-/-
9	C	Band Reject Filter	WRCJV12-5695-5725-5850-5880-40SS	Wainwright	5	300005169	ev	-/-	-/-
10	C	Band Reject Filter	WRCJV16-5440-5470-5725-5755-40SS	Wainwright	9	300005170	ev	-/-	-/-

11	B, C	RF-Amplifier	AMF-6F06001800-30-10P-R	NARDA-MITEQ Inc	2011571	300005240	ev	-/-	-/-
12	A, B, C	EMI Test Receiver 9kHz-26,5GHz	ESR26	R&S	101376	300005063	k	19.12.2018	18.12.2019

6.3 Radiated measurements > 18 GHz

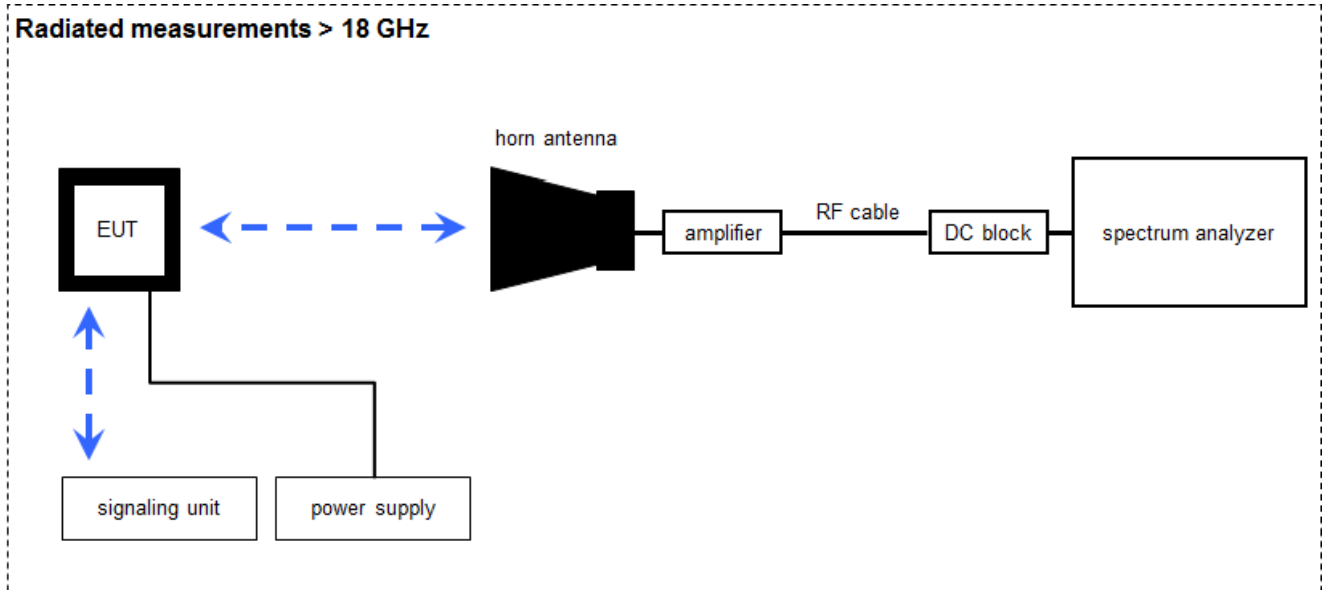

Measurement distance: horn antenna 50 cm

$$FS = UR + CA + AF$$

(FS-field strength; UR-voltage at the receiver; CA-loss signal path & distance correction; AF-antenna factor)

Example calculation:

$$FS [dB\mu V/m] = 40.0 [dB\mu V/m] + (-60.1) [dB] + 36.74 [dB/m] = 16.64 [dB\mu V/m] (6.79 \mu V/m)$$

Equipment table:

No.	Lab / Item	Equipment	Type	Manufacturer	Serial No.	INV. No.	Kind of Calibration	Last Calibration	Next Calibration
1	A	Amplifier 2-40 GHz	JS32-02004000-57-5P	MITEQ	1777200	300004541	ev	-/-	-/-
2	A	RF-Cable	ST18/SMAm/SMAm /48	Huber & Suhner	Batch no. 600918	400001182	ev	-/-	-/-
3	A	RF-Cable	ST18/SMAm/SMAm /48	Huber & Suhner	Batch no. 127377	400001183	ev	-/-	-/-
4	A	DC-Blocker 0.1-40 GHz	8141A	Inmet	-/-	400001185	ev	-/-	-/-
5	A	Std. Gain Horn Antenna 18.0-26.5 GHz	638	Narda	-/-	300000486	vIKI!	13.12.2017	12.12.2019
6	A	Signal Analyzer 40 GHz	FSV40	R&S	101042	300004517	vIKI!	17.12.2018	16.12.2019

6.4 Conducted measurements

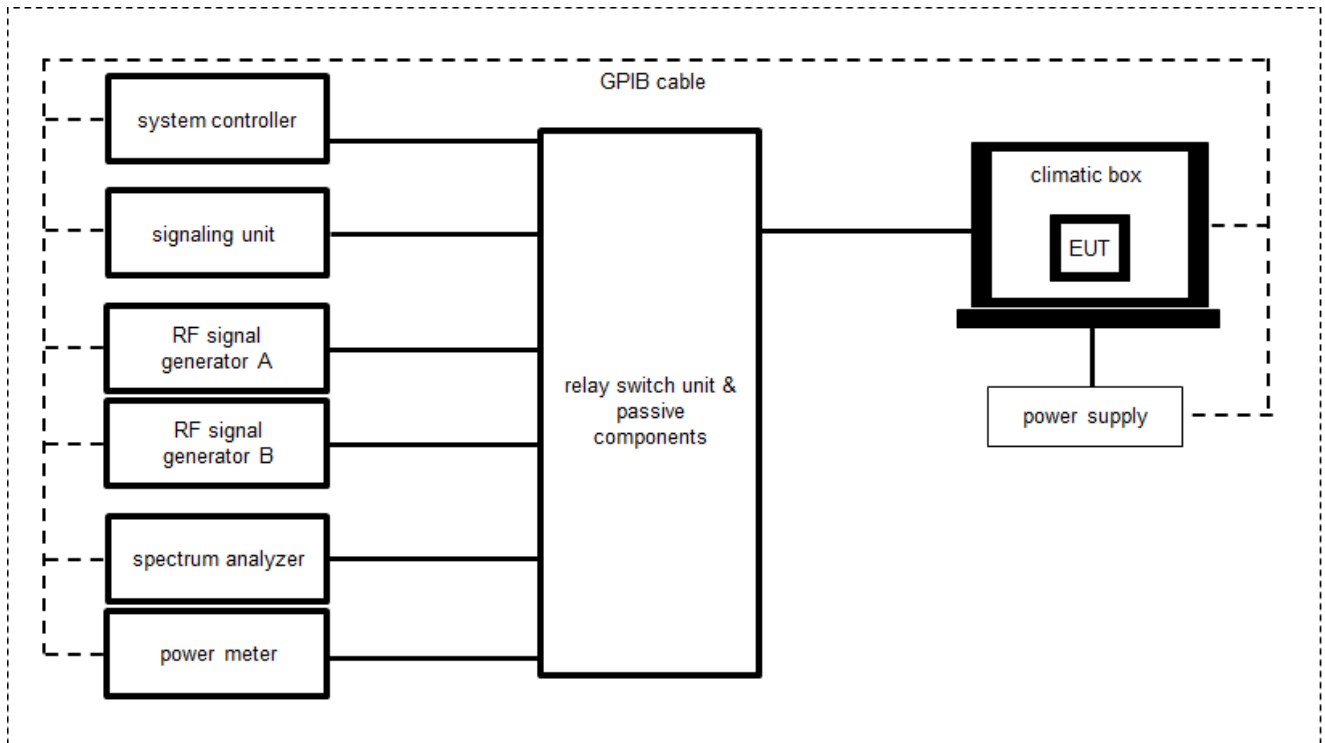

OP = AV + CA
(OP-output power; AV-analyzer value; CA-loss signal path)

Example calculation:

OP [dBm] = 6.0 [dBm] + 11.7 [dB] = 17.7 [dBm] (58.88 mW)

Equipment table:

No.	Lab / Item	Equipment	Type	Manufacturer	Serial No.	INV. No.	Kind of Calibration	Last Calibration	Next Calibration
1	A	PC Laboratory	Exone	Fröhlich + Walter	S2642279-03 / 10	300004179	ne	-/-	-/-
2	A	Spectrum Analyzer	FSV30	Rohde & Schwarz	103809	300005359	vKI!	17.12.2018	16.12.2020
3	A	Relay Switch Matrix	RSM-1	CTC advanced GmbH	0001	400001355	ev	14.06.2019	13.06.2020
4	A	Tester Software RadioStar (C.BER2 for BT Conformance)	Version 1.0.0.X	CTC advanced GmbH	0001	400001380	ne	-/-	-/-

6.5 AC conducted

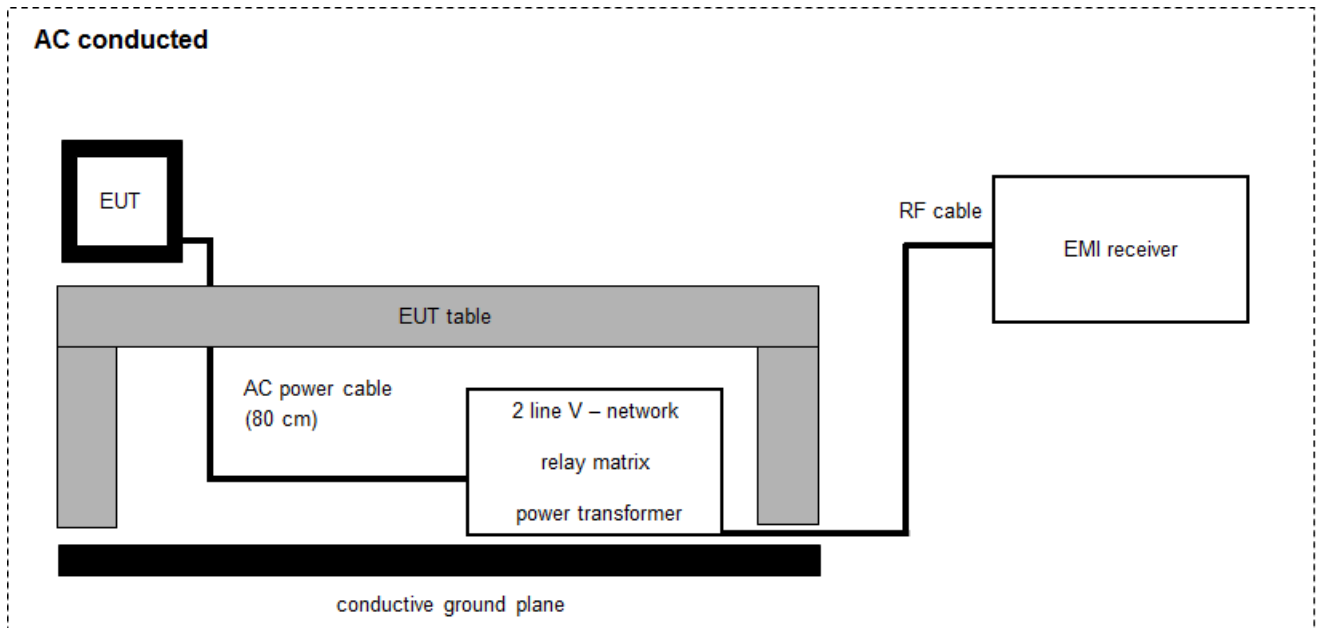

$$FS = UR + CF + VC$$

(FS-field strength; UR-voltage at the receiver; CR-loss of the cable and filter; VC-correction factor of the ISN)

Example calculation:

$$FS [dB\mu V/m] = 37.62 [dB\mu V/m] + 9.90 [dB] + 0.23 [dB] = 47.75 [dB\mu V/m] (244.06 \mu V/m)$$

Equipment table:

No.	Lab / Item	Equipment	Type	Manufacturer	Serial No.	INV. No.	Kind of Calibration	Last Calibration	Next Calibration
1	A	Two-line V-Network (LISN) 9 kHz to 30 MHz	ESH3-Z5	R&S	892475/017	300002209	vKI!	13.12.2017	12.12.2019
2	A	RF-Filter-section	85420E	HP	3427A00162	300002214	NK!	-/-	-/-
3	A	EMI Test Receiver	ESCI 3	R&S	100083	300003312	k	12.12.2018	11.12.2019
4	A	Hochpass 150 kHz	EZ-25	R&S	100010	300003798	ev	-/-	-/-

7 Measurement uncertainty

Measurement uncertainty		
Test case	Uncertainty	
Antenna gain	± 3 dB	
Power spectral density	± 1.15 dB	
Spectrum bandwidth	± 100 kHz (depends on the used RBW)	
Occupied bandwidth	± 100 kHz (depends on the used RBW)	
Maximum output power	± 1.15 dB conducted ± 3 dB radiated	
Minimum emissions bandwidth	± 100 kHz (depends on the used RBW)	
Band edge compliance radiated	± 3 dB	
Spurious emissions conducted	> 3.6 GHz	± 1.15 dB
	> 7 GHz	± 1.15 dB
	> 18 GHz	± 1.89 dB
	≥ 40 GHz	± 3.12 dB
Spurious emissions radiated below 30 MHz	± 3 dB	
Spurious emissions radiated 30 MHz to 1 GHz	± 3 dB	
Spurious emissions radiated 1 GHz to 12.75 GHz	± 3.7 dB	
Spurious emissions radiated above 12.75 GHz	± 4.5 dB	
Spurious emissions conducted below 30 MHz (AC conducted)	± 2.6 dB	

8 Sequence of testing

8.1 Sequence of testing radiated spurious 9 kHz to 30 MHz

Setup

- The equipment is set up to simulate normal operation mode as described in the user manual or defined by the manufacturer.
- If the EUT is a tabletop system, it is placed on a table with 0.8 m height.
- If the EUT is a floor standing device, it is placed directly on the turn table.
- Auxiliary equipment and cables are positioned to simulate normal operation conditions as described in ANSI C 63.4.
- The AC power port of the EUT (if available) is connected to a power outlet below the turntable.
- Measurement distance is 3 m (see ANSI C 63.4) – see test details.
- EUT is set into operation.

Premeasurement*

- The turntable rotates from 0° to 315° using 45° steps.
- The antenna height is 1 m.
- At each turntable position the analyzer sweeps with positive-peak detector to find the maximum of all emissions.

Final measurement

- Identified emissions during the pre-measurement are maximized by the software by rotating the turntable from 0° to 360°.
- Loop antenna is rotated about its vertical axis for maximum response at each azimuth about the EUT. (For certain applications, the loop antenna plane may also need to be positioned horizontally at the specified distance from the EUT)
- The final measurement is done in the position (turntable and elevation) causing the highest emissions with quasi-peak (as described in ANSI C 63.4).
- Final levels, frequency, measuring time, bandwidth, turntable position, correction factor, margin to the limit and limit will be recorded. A plot with the graph of the premeasurement and the limit is stored.

*Note: The sequence will be repeated three times with different EUT orientations.

8.2 Sequence of testing radiated spurious 30 MHz to 1 GHz

Setup

- The equipment is set up to simulate normal operation mode as described in the user manual or defined by the manufacturer.
- If the EUT is a tabletop system, a table with 0.8 m height is used, which is placed on the ground plane.
- If the EUT is a floor standing device, it is placed on the ground plane with insulation between both.
- Auxiliary equipment and cables are positioned to simulate normal operation conditions as described in ANSI C 63.4.
- The AC power port of the EUT (if available) is connected to a power outlet below the turntable.
- Measurement distance is 10 m or 3 m (see ANSI C 63.4) – see test details.
- EUT is set into operation.

Premeasurement

- The turntable rotates from 0° to 315° using 45° steps.
- The antenna is polarized vertical and horizontal.
- The antenna height changes from 1 m to 3 m.
- At each turntable position, antenna polarization and height the analyzer sweeps three times in peak to find the maximum of all emissions.

Final measurement

- The final measurement is performed for at least six highest peaks according to the requirements of the ANSI C63.4.
- Based on antenna and turntable positions at which the peak values are measured the software maximize the peaks by changing turntable position $\pm 45^\circ$ and antenna height between 1 and 4 m.
- The final measurement is done with quasi-peak detector (as described in ANSI C 63.4).
- Final levels, frequency, measuring time, bandwidth, antenna height, antenna polarization, turntable angle, correction factor, margin to the limit and limit are recorded. A plot with the graph of the premeasurement with marked maximum final results and the limit is stored.

8.3 Sequence of testing radiated spurious 1 GHz to 18 GHz

Setup

- The equipment is set up to simulate normal operation mode as described in the user manual or defined by the manufacturer.
- If the EUT is a tabletop system, a 2-axis positioner with 1.5 m height is used.
- If the EUT is a floor standing device, it is placed directly on the turn table.
- Auxiliary equipment and cables are positioned to simulate normal operation conditions as described in ANSI C 63.4.
- The AC power port of the EUT (if available) is connected to a power outlet below the turntable.
- Measurement distance is 3 m (see ANSI C 63.4) – see test details.
- EUT is set into operation.

Premeasurement

- The turntable rotates from 0° to 315° using 45° steps.
- The antenna is polarized vertical and horizontal.
- The antenna height is 1.5 m.
- At each turntable position and antenna polarization the analyzer sweeps with positive peak detector to find the maximum of all emissions.

Final measurement

- The final measurement is performed for at least six highest peaks according to the requirements of the ANSI C63.4.
- Based on antenna and turntable positions at which the peak values are measured the software maximizes the peaks by rotating the turntable from 0° to 360°. This measurement is repeated for different EUT-table positions (0° to 150° in 30°-steps) and for both antenna polarizations.
- The final measurement is done in the position (turntable, EUT-table and antenna polarization) causing the highest emissions with Peak and RMS detector (as described in ANSI C 63.4).
- Final levels, frequency, measuring time, bandwidth, turntable position, EUT-table position, antenna polarization, correction factor, margin to the limit and limit are recorded. A plot with the graph of the premeasurement with marked maximum final results and the limit is stored.

8.4 Sequence of testing radiated spurious above 18 GHz

Setup

- The equipment is set up to simulate normal operation mode as described in the user manual or defined by the manufacturer.
- Auxiliary equipment and cables are positioned to simulate normal operation conditions as described in ANSI C 63.4.
- The AC power port of the EUT (if available) is connected to a power outlet.
- The measurement distance is as appropriate (e.g. 0.5 m).
- The EUT is set into operation.

Premeasurement

- The test antenna is handheld and moved carefully over the EUT to cover the EUT's whole sphere and different polarizations of the antenna.

Final measurement

- The final measurement is performed at the position and antenna orientation causing the highest emissions with Peak and RMS detector (as described in ANSI C 63.4).
- Final levels, frequency, measuring time, bandwidth, correction factor, margin to the limit and limit are recorded. A plot with the graph of the premeasurement and the limit is stored.

9 Summary of measurement results

<input type="checkbox"/>	No deviations from the technical specifications were ascertained
<input type="checkbox"/>	There were deviations from the technical specifications ascertained
<input checked="" type="checkbox"/>	This test report is only a partial test report. The content and verdict of the performed test cases are listed below.

TC Identifier	Description	Verdict	Date	Remark
RF-Testing	CFR Title 47 Part 15 RSS 247, Issue 2	See table	2019-12-11	-/-

Test specification clause	Test case	C	NC	NA	NP	Remark
-/-	Output power verification (cond.)	-/-				Stand-alone configuration
-/-	Antenna gain	-/-				Stand-alone configuration
U-NII Part 15	Duty cycle	-/-				Stand-alone configuration
§15.407(a) RSS - 247 (6.2.x.1)	Maximum output power (conducted & radiated)	<input checked="" type="checkbox"/>	<input type="checkbox"/>	<input type="checkbox"/>	<input type="checkbox"/>	Stand-alone configuration
§15.407(a) RSS - 247 (6.2.x.1)	Power spectral density	<input checked="" type="checkbox"/>	<input type="checkbox"/>	<input type="checkbox"/>	<input type="checkbox"/>	Stand-alone configuration
RSS - 247 (6.2.4.1)	Spectrum bandwidth 6dB bandwidth	<input checked="" type="checkbox"/>	<input type="checkbox"/>	<input type="checkbox"/>	<input type="checkbox"/>	Stand-alone configuration
§15.407(a) RSS - 247 (6.2.x.2)	Spectrum bandwidth 26dB bandwidth	<input checked="" type="checkbox"/>	<input type="checkbox"/>	<input type="checkbox"/>	<input type="checkbox"/>	Stand-alone configuration
RSS Gen clause 6.6	Spectrum bandwidth 99% bandwidth	-/-				Stand-alone configuration
§15.205 RSS - 247 (6.2.x.2)	Band edge compliance radiated	<input checked="" type="checkbox"/>	<input type="checkbox"/>	<input type="checkbox"/>	<input type="checkbox"/>	Stand-alone configuration
§15.407(b) RSS - 247 (6.2.x.2)	TX spurious emissions radiated	<input checked="" type="checkbox"/>	<input type="checkbox"/>	<input type="checkbox"/>	<input type="checkbox"/>	30 MHz to 1 GHz: Tests in a host Above 1 GHz: Stand-alone configuration
§15.109 RSS-Gen	RX spurious emissions radiated	<input checked="" type="checkbox"/>	<input type="checkbox"/>	<input type="checkbox"/>	<input type="checkbox"/>	30 MHz to 1 GHz: Tests in a host Above 1 GHz: Stand-alone configuration
§15.209(a) RSS-Gen	Spurious emissions radiated < 30 MHz	<input checked="" type="checkbox"/>	<input type="checkbox"/>	<input type="checkbox"/>	<input type="checkbox"/>	Stand-alone configuration
§15.107(a) §15.207	Spurious emissions conducted emissions < 30 MHz	<input checked="" type="checkbox"/>	<input type="checkbox"/>	<input type="checkbox"/>	<input type="checkbox"/>	Tests in a host
§15.407 RSS - 247 (6.3)	DFS	<input type="checkbox"/>	<input type="checkbox"/>	<input type="checkbox"/>	<input checked="" type="checkbox"/>	-/-

Notes:

C: Compliant	NC: Not compliant	NA: Not applicable	NP: Not performed
---------------------	--------------------------	---------------------------	--------------------------

10 Additional comments

Reference documents: ICO-OPE-03994 Wifi_labtool_Radio_agreement_procedure.pdf
1- 8503_19-01-09_Annex_MR_A_1.pdf

Special test descriptions: The radiated spurious emissions tests between 30 MHz and 1 GHz were performed with one Xtra module in a LANE8000 host and one Xtra module in a LANE7000 host. Both hosts were in the semi-anechoic chamber at the same time and the modules were always transmitting in the same mode and on the same channel. This represents the worst case and therefore covers both possible Xtra module use cases.
As the Xtra module will be only used in LANE8000 and LANE7000 hosts, the module can be only used for this two use cases. All other tests were performed with a module stand-alone configuration. For 30 MHz to 1 GHz spurious tests the stand-alone configuration was not compliant due to unshielded cables which were used for the stand-alone test setup and are not part of the end product.

Configuration descriptions: Power settings used for all tests: a-mode: 14
n20-mode: 13
n40-mode: 11

Provided channels:

Channels with 20 MHz channel bandwidth:

U-NII-2C (5470 MHz to 5725 MHz) channel number & center frequency											
channel	100	104	108	112	116	120	124	128	132	136	140
f _c / MHz	5500	5520	5540	5560	5580	5600	5620	5640	5660	5680	5700

Channels with 40 MHz channel bandwidth:

U-NII-2C (5470 MHz to 5725 MHz) channel number & center frequency					
channel	102	110	118	126	134
f _c / MHz	5510	5550	5590	5630	5670

Test mode:

- No test mode available.
lperf is used to transmit data to a companion device
- Special software is used.
EUT is transmitting pseudo random data by itself

Antennas and transmit operating modes:

- Operating mode 1 (single antenna)
 - Equipment with 1 antenna,
 - Equipment with 2 diversity antennas operating in switched diversity mode by which at any moment in time only 1 antenna is used,
 - Smart antenna system with 2 or more transmit/receive chains, but operating in a mode where only 1 transmit/receive chain is used)
- Operating mode 2 (multiple antennas, no beamforming)
 - Equipment operating in this mode contains a smart antenna system using two or more transmit/receive chains simultaneously but without beamforming.
- Operating mode 3 (multiple antennas, with beamforming)
 - Equipment operating in this mode contains a smart antenna system using two or more transmit/receive chains simultaneously with beamforming.
In addition to the antenna assembly gain (G), the beamforming gain (Y) may have to be taken into account when performing the measurements.

11 Measurement results

11.1 Identify worst case data rate

Measurement:

All modes of the module will be measured with an average power meter to identify the maximum transmission power on mid channel. In the case that only one or two channels are available, only these will be measured.

In further tests only the identified worst case modulation scheme or bandwidth will be measured.

Measurement parameters:

Measurement parameter	
Detector:	Peak
Sweep time:	Auto
Resolution bandwidth:	3 MHz
Video bandwidth:	3 MHz
Trace mode:	Max hold
Used test setup:	See chapter 6.4 – A
Measurement uncertainty:	See chapter 6

Results:

OFDM – mode	Modulation scheme / bandwidth					
	U-NII-1 & U-NII-2A		U-NII-2C		U-NII-3	
	lowest channel	highest channel	lowest channel	highest channel	lowest channel	highest channel
a – mode	Mbit/s	Mbit/s	6 Mbit/s	6 Mbit/s	Mbit/s	Mbit/s
n HT20 – mode	MCS	MCS	MCS0	MCS0	MCS	MCS
n HT40 – mode	MCS	MCS	MCS0	MCS0	MCS	MCS

11.2 Antenna gain

Description:

The antenna gain of the complete system is calculated by the difference of radiated power in EIRP and the conducted power of the module.

Measurement parameters:

Measurement parameter	
External result file(s)	1-8503_19-01-09_Annex_MR_A_1.pdf Peak OP 3MHz/3MHz
Test setup:	See chapter 6.2 – A (radiated) See chapter 6.3 – A (conducted)
Measurement uncertainty:	See chapter 6

Limits:

Antenna Gain
6 dBi / > 6 dBi output power and power density reduction required

Results:

U-NII-2C (5470 MHz to 5725 MHz)	Antenna gain		
	Lowest channel	Middle channel	Highest channel
Conducted power / dBm @ 3 MHz RBW	11.6	11.3	12.2
Radiated power / dBm @ 3 MHz RBW	6.2	8.0	12.1
Gain / dBi (calculated or declared)	-5.4	-3.3	-0.1

11.3 Duty cycle

Description:

The duty cycle is necessary to compute the maximum power during an actual transmission. The shown plots and values are to show an example of the measurement procedure. The real value is measured direct during the power measurement or power density measurement. The correction value is shown in each plot of these measurements.

Measurement:

Measurement parameter	
According to: KDB789033 D02, B.	
External result file(s)	1-8503_19-01-09_Annex_MR_A_1.pdf FCC Part 15.407 Max Output Power and PSD
Used test setup:	See chapter 6.4 – A
Measurement uncertainty:	See chapter 6

Results:

Duty cycle and correction factor:

OFDM – mode	Duty cycle	Correction factor
a – mode	100%	0.0 dB
n HT20 – mode	100%	0.0 dB
n HT40 – mode	100%	0.0 dB

11.4 Maximum output power

11.4.1 Maximum output power according to FCC requirements

Description:

Measurement of the maximum output power conducted

Measurement:

Measurement parameter	
According to: KDB789033 D02, E.2.e.	
External result file(s)	1-8503_19-01-09_Annex_MR_A_1.pdf FCC Part 15.407 Max Output Power and PSD
Used test setup:	See chapter 6.4 – A
Measurement uncertainty:	See chapter 6

Limits:

Radiated output power	Conducted output power for mobile equipment
Conducted power + 6 dBi antenna gain	The lesser one of 250mW or 11 dBm + 10 log Bandwidth 5.470-5.725 GHz (where Bandwidth is the 26dB Bandwidth [MHz])

Results:

a	Maximum output power conducted [dBm]		
	U-NII-2C (5470 MHz to 5725 MHz)		
	Lowest channel	Middle channel	Highest channel
	10.3	9.2	10.8

Results:

n HT20	Maximum output power conducted [dBm]		
	U-NII-2C (5470 MHz to 5725 MHz)		
	Lowest channel	Middle channel	Highest channel
	9.4	7.8	9.9

Results:

n HT40	Maximum output power conducted [dBm]		
	U-NII-2C (5470 MHz to 5725 MHz)		
	Lowest channel	Middle channel	Highest channel
	5.9	5.2	6.6

11.4.2 Maximum output power according to IC requirements

Description:

Measurement of the maximum output power conducted + radiated

Measurement:

Measurement parameter	
External result file(s)	1-8503_19-01-09_Annex_MR_A_1.pdf ISED Max Output Power and PSD
Used test setup:	See chapter 6.4 – A
Measurement uncertainty:	See chapter 6

Limits:

Radiated output power	Conducted output power for mobile equipment
The lesser one of 1 W or 17 dBm + 10 log Bandwidth 5.470-5.725 GHz (where Bandwidth is the 99% Bandwidth [MHz])	The lesser one of 250mW or 11 dBm + 10 log Bandwidth 5.470-5.725 GHz (where Bandwidth is the 99% Bandwidth [MHz])

Results:

a	Maximum output power [dBm]		
	U-NII-2C (5470 MHz to 5725 MHz)		
	Lowest channel	Middle channel	Highest channel
	Conducted		
	10.2	9.2	10.7
	Radiated (calculated – see chapter antenna gain)		
4.8	5.9	10.6	

n HT20	Maximum output power [dBm]		
	U-NII-2C (5470 MHz to 5725 MHz)		
	Lowest channel	Middle channel	Highest channel
	Conducted		
	9.3	7.7	9.7
	Radiated (calculated – see chapter antenna gain)		
3.9	4.4	9.6	

Results:

n HT40	Maximum output power [dBm]		
	U-NII-2C (5470 MHz to 5725 MHz)		
	Lowest channel	Middle channel	Highest channel
	Conducted		
	5.9	5.5	6.6
	Radiated (calculated – see chapter antenna gain)		
	0.5	2.2	6.5

11.5 Power spectral density

11.5.1 Power spectral density according to FCC requirements

Description:

Measurement of the power spectral density of a digital modulated system. The measurement is repeated at the lowest, middle and highest channel.

Measurement:

Measurement parameter	
According to: KDB789033 D02, F.	
External result file(s)	1-8503_19-01-09_Annex_MR_A_1.pdf FCC Part 15.407 Max Output Power and PSD
Used test setup:	See chapter 6.4 – A
Measurement uncertainty:	See chapter 6

Limits:

Power Spectral Density
power spectral density conducted ≤ 11 dBm in any 1 MHz band (band 5470 – 5725 MHz)

Results:

a	Power spectral density (dBm/1MHz or dBm/500kHz)		
	U-NII-2C (5470 MHz to 5725 MHz)		
	Lowest channel	Middle channel	Highest channel
	-1.4	-2.5	-0.7

Results:

n HT20	Power spectral density (dBm/1MHz or dBm/500kHz)		
	U-NII-2C (5470 MHz to 5725 MHz)		
	Lowest channel	Middle channel	Highest channel
	-2.6	-4.2	-1.7

Results:

n HT40	Power spectral density (dBm/1MHz or dBm/500kHz)		
	U-NII-2C (5470 MHz to 5725 MHz)		
	Lowest channel	Middle channel	Highest channel
	-9.2	-9.5	-8.3

11.5.2 Power spectral density according to IC requirements

Description:

Measurement of the power spectral density of a digital modulated system. The measurement is repeated at the lowest, middle and highest channel.

Measurement:

Measurement parameter	
External result file(s)	1-8503_19-01-09_Annex_MR_A_1.pdf ISED Max Output Power and PSD
Used test setup:	See chapter 6.4 – A
Measurement uncertainty:	See chapter 6

Limits:

Power Spectral Density
power spectral density conducted ≤ 11 dBm in any 1 MHz band (band 5470 – 5725 MHz)

Results:

a	Power spectral density (dBm/1MHz or dBm/500kHz)		
	U-NII-2C (5470 MHz to 5725 MHz)		
	Lowest channel	Middle channel	Highest channel
	-1.5	-2.5	-0.8

Results:

n HT20	Power spectral density (dBm/1MHz or dBm/500kHz)		
	U-NII-2C (5470 MHz to 5725 MHz)		
	Lowest channel	Middle channel	Highest channel
	-2.6	-4.3	-1.9

Results:

n HT40	Power spectral density (dBm/1MHz or dBm/500kHz)		
	U-NII-2C (5470 MHz to 5725 MHz)		
	Lowest channel	Middle channel	Highest channel
	-9.2	-9.5	-8.3

11.6 Spectrum bandwidth / 26 dB bandwidth

Description:

Measurement of the 26 dB bandwidth of the modulated signal.

Measurement:

Measurement parameter	
According to: KDB789033 D02, C.1.	
External result file(s)	1-8503_19-01-09_Annex_MR_A_1.pdf FCC Part 15.407 & ISED Bandwidths
Used test setup:	see chapter 6.4 – A
Measurement uncertainty:	See chapter 6

Limits:

Spectrum Bandwidth – 26 dB Bandwidth
<p>IC: Any unwanted emissions that fall into the band 5250-5350 MHz shall be attenuated below the channel power by at least 26 dB, when measured using a resolution bandwidth between 1 and 5% of the occupied bandwidth (i.e. 99% bandwidth), above 5250 MHz. The 26 dB bandwidth may fall into the 5250-5350 MHz band; however, if the occupied bandwidth also falls within the 5250-5350 MHz band, the transmission is considered as intentional and the devices shall comply with all requirements in the band 5250-5350 MHz including implementing dynamic frequency selection (DFS) and TPC, on the portion of the emission that resides in the 5250-5350 MHz band.</p> <p>FCC: Radar Detection Function of Dynamic Frequency Selection (DFS). U-NII devices operating with any part of its 26 dB emission bandwidth in the 5.25-5.35 GHz and 5.47-5.725 GHz bands shall employ a DFS radar detection mechanism to detect the presence of radar systems and to avoid co-channel operation with radar systems.</p>

Results:

a	26 dB bandwidth (MHz)		
	U-NII-2C (5470 MHz to 5725 MHz)		
	Lowest channel	Middle channel	Highest channel
	20.1	20.2	20.3

Results:

n HT20	26 dB bandwidth (MHz)		
	U-NII-2C (5470 MHz to 5725 MHz)		
	Lowest channel	Middle channel	Highest channel
	20.6	20.6	20.7

Results:

n HT40	26 dB bandwidth (MHz)		
	U-NII-2C (5470 MHz to 5725 MHz)		
	Lowest channel	Middle channel	Highest channel
	41.5	41.5	41.4

11.7 Occupied bandwidth / 99% emission bandwidth

Description:

Measurement of the 99% bandwidth of the modulated signal acc. RSS-GEN.

Measurement:

Measurement parameter	
External result file(s)	1-8503_19-01-09_Annex_MR_A_1.pdf FCC Part 15.407 & ISED Bandwidths
Test setup:	See sub clause 6.5 – B
Measurement uncertainty:	See chapter 6

Usage:

-/-	IC
OBW is necessary for Emission Designator	

Results:

a	99% bandwidth (kHz)		
	U-NII-2C (5470 MHz to 5725 MHz)		
	Lowest channel	Middle channel	Highest channel
	16783	16833	16883

Results:

n HT20	99% bandwidth (kHz)		
	U-NII-2C (5470 MHz to 5725 MHz)		
	Lowest channel	Middle channel	Highest channel
	17882	17932	17932

Results:

n HT40	99% bandwidth (kHz)		
	U-NII-2C (5470 MHz to 5725 MHz)		
	Lowest channel	Middle channel	Highest channel
	36763	36763	36563

11.8 Band edge compliance radiated

Description:

Measurement of the radiated band edge compliance. The EUT is turned in the position that results in the maximum level at the band edge. Then a sweep over the corresponding restricted band is performed. The EUT is set to the lowest channel for the lower restricted band and to the highest channel for the upper restricted band. Measurement distance is 3m.

Measurement:

Measurement parameter	
Detector:	Peak / RMS
Sweep time:	Auto
Resolution bandwidth:	1 MHz
Video bandwidth:	≥ 3 x RBW
Span:	See plots!
Trace mode:	Max Hold
Test setup:	See sub clause 6.2 – A
Measurement uncertainty:	See chapter 6

Limits:

Band Edge Compliance Radiated
In any 100 kHz bandwidth outside the frequency band in which the spread spectrum or digitally modulated intentional radiator is operating, the radio frequency power that is produced by the intentional radiator shall be at least 20 dB below that in the 100 kHz bandwidth within the band that contains the highest level of the desired power, based on either an RF conducted or a radiated measurement. Attenuation below the general limits specified in Section 15.209(a) is not required. In addition, radiated emissions which fall in the restricted bands, as defined in Section 15.205(a), must also comply with the radiated emission limits specified in Section 15.209(a) (see Section 5.205(c)).
74 dBµV/m (peak) 54 dBµV/m (average)

Result:

Scenario	Band Edge Compliance Radiated [dBµV/m]
band edge	< 74 dBµV/m (peak) < 54 dBµV/m (average)

Plots:

Plot 1: lower band edge; U-NII-2C; lowest channel; 20 MHz channel bandwidth

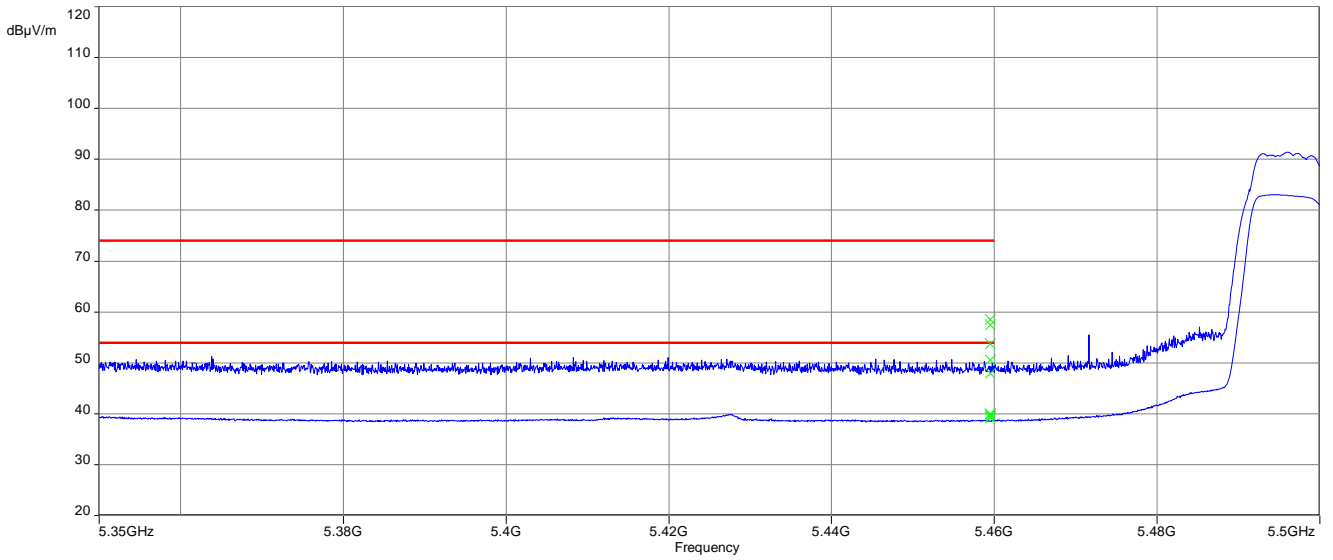

Plot 2: lower band edge; U-NII-2C; lowest channel; 40 MHz channel bandwidth

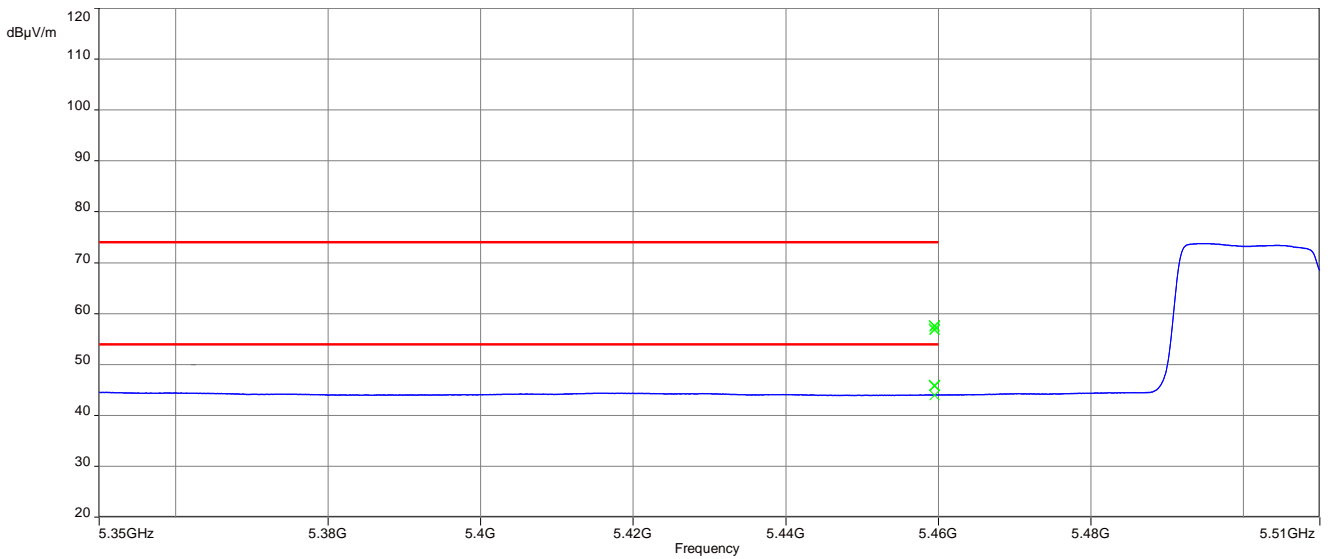

11.9 Spurious emissions radiated below 30 MHz

Description:

Measurement of the radiated spurious emissions in transmit mode below 30 MHz. The limits are re-calculated to a measurement distance of 3 m with 40 dB/decade according CFR Part 2.

Measurement:

Measurement parameter	
Detector:	Peak / Quasi Peak
Sweep time:	Auto
Video bandwidth:	F < 150 kHz: 200 Hz F > 150 kHz: 9 kHz
Resolution bandwidth:	F < 150 kHz: 1 kHz F > 150 kHz: 100 kHz
Span:	9 kHz to 30 MHz
Trace mode:	Max Hold
Test setup:	See sub clause 6.2 – C
Measurement uncertainty:	See chapter 6

Limits:

Spurious Emissions Radiated < 30 MHz		
Frequency (MHz)	Field Strength (dBµV/m)	Measurement distance
0.009 – 0.490	2400/F(kHz)	300
0.490 – 1.705	24000/F(kHz)	30
1.705 – 30.0	30	30

Results:

Spurious Emissions Radiated < 30 MHz [dBµV/m]		
F [MHz]	Detector	Level [dBµV/m]
All detected emissions are more than 20 dB below the limit.		

Plots: 20 MHz channel bandwidth

Plot 1: 9 kHz to 30 MHz, U-NII-2C; lowest channel

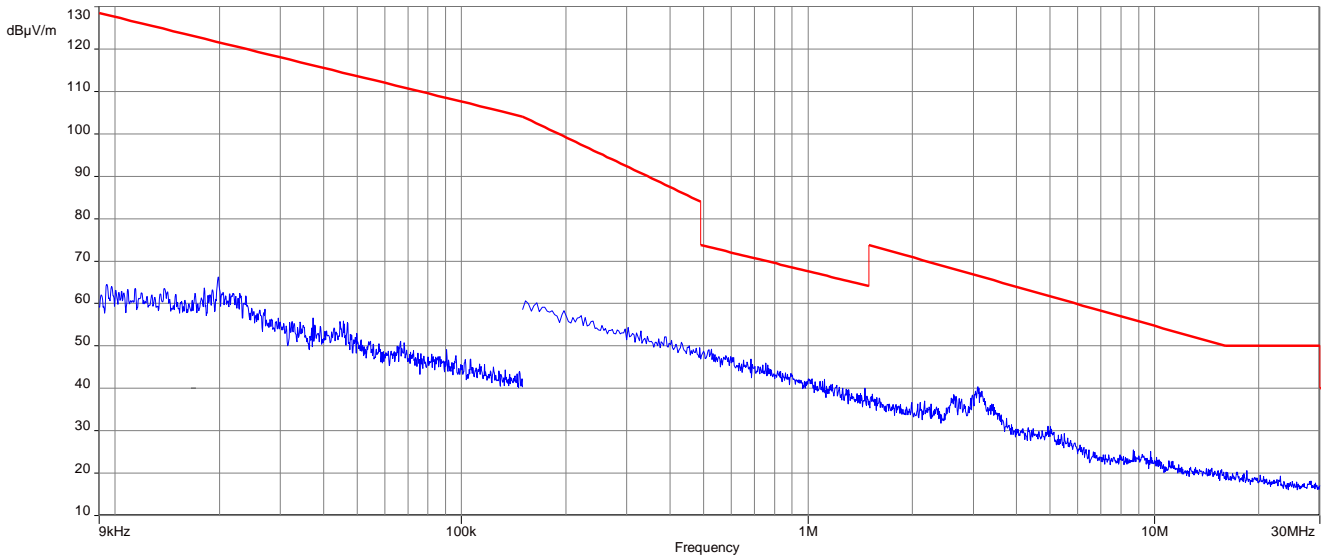

Plot 2: 9 kHz to 30 MHz, U-NII-2C; middle channel

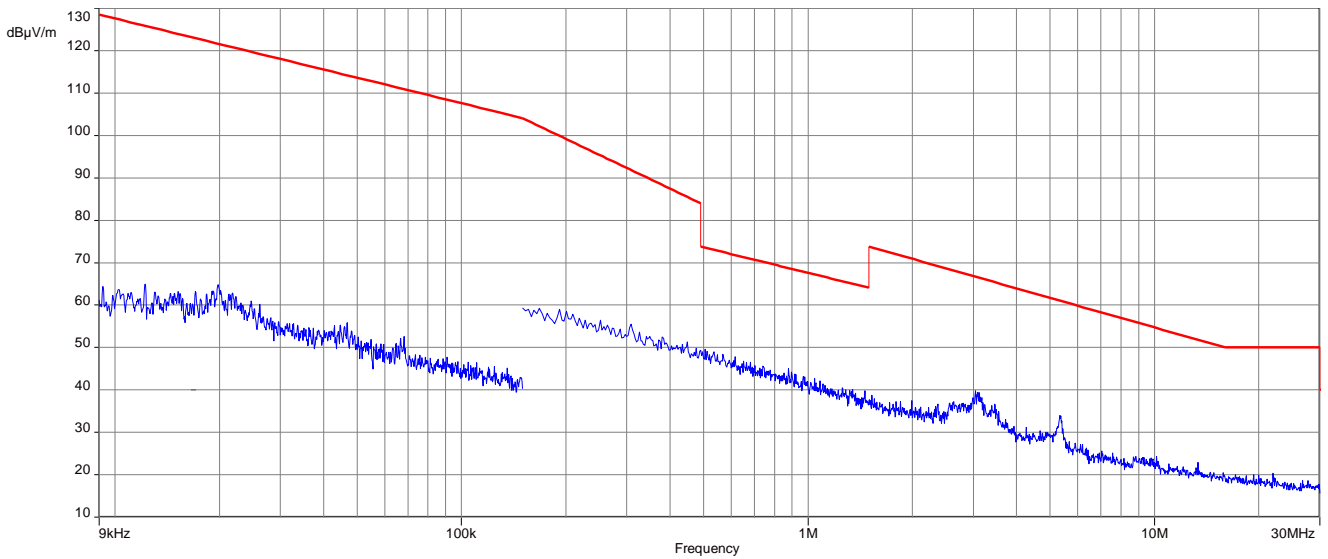

Plot 3: 9 kHz to 30 MHz, U-NII-2C; highest channel

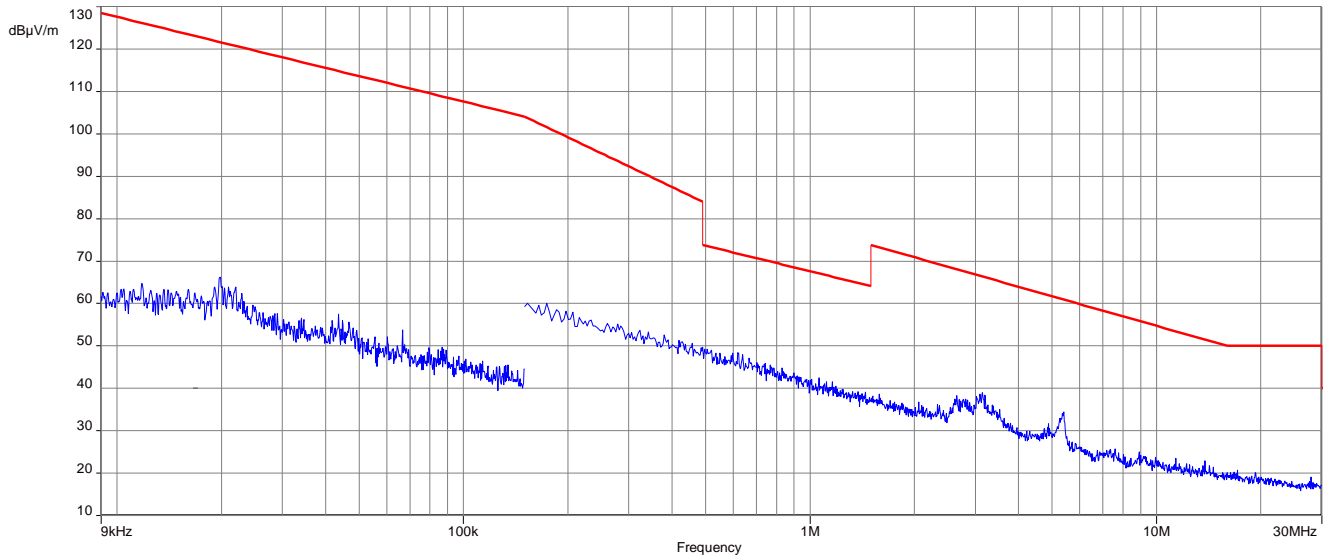

Plots: 40 MHz channel bandwidth

Plot 1: 9 kHz to 30 MHz, U-NII-2C; lowest channel

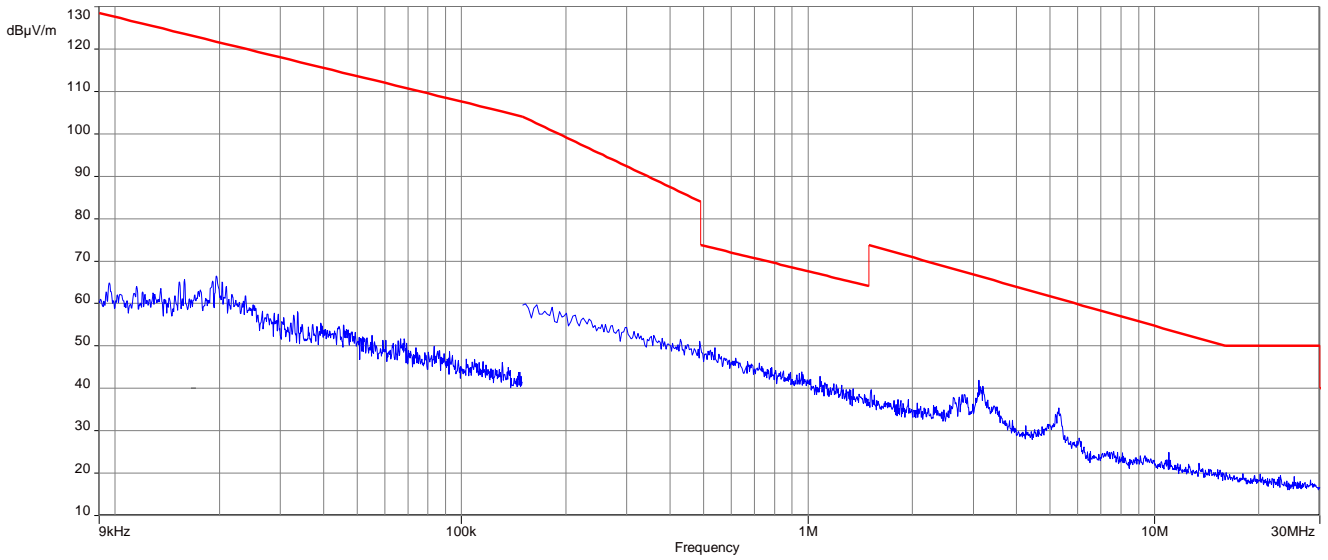

Plot 2: 9 kHz to 30 MHz, U-NII-2C; middle channel

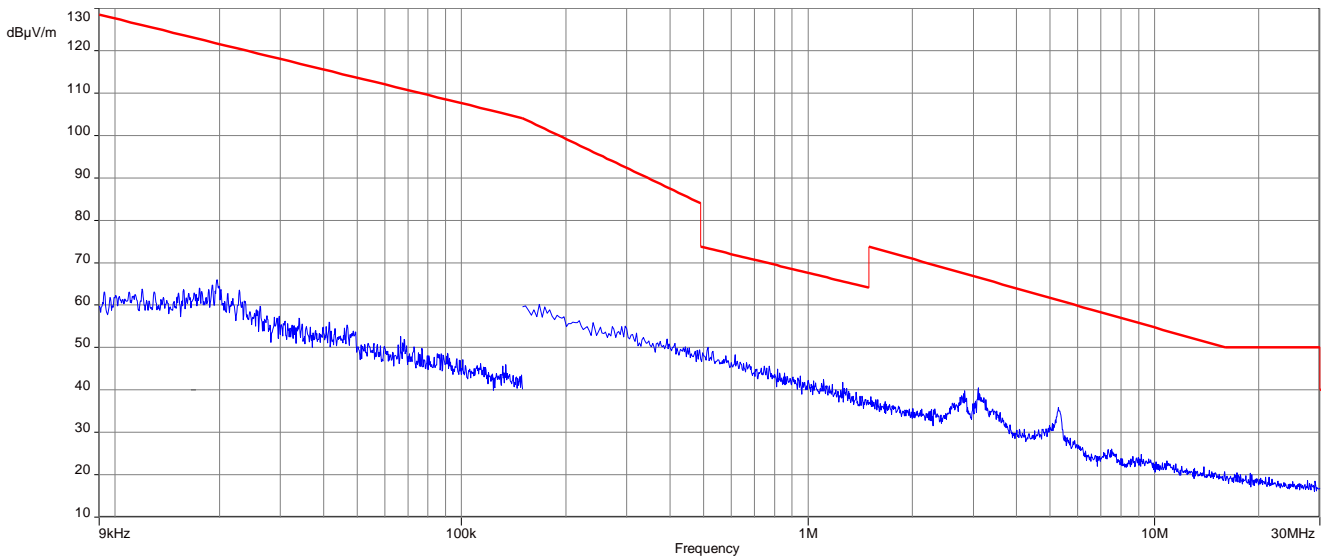

Plot 3: 9 kHz to 30 MHz, U-NII-2C; highest channel

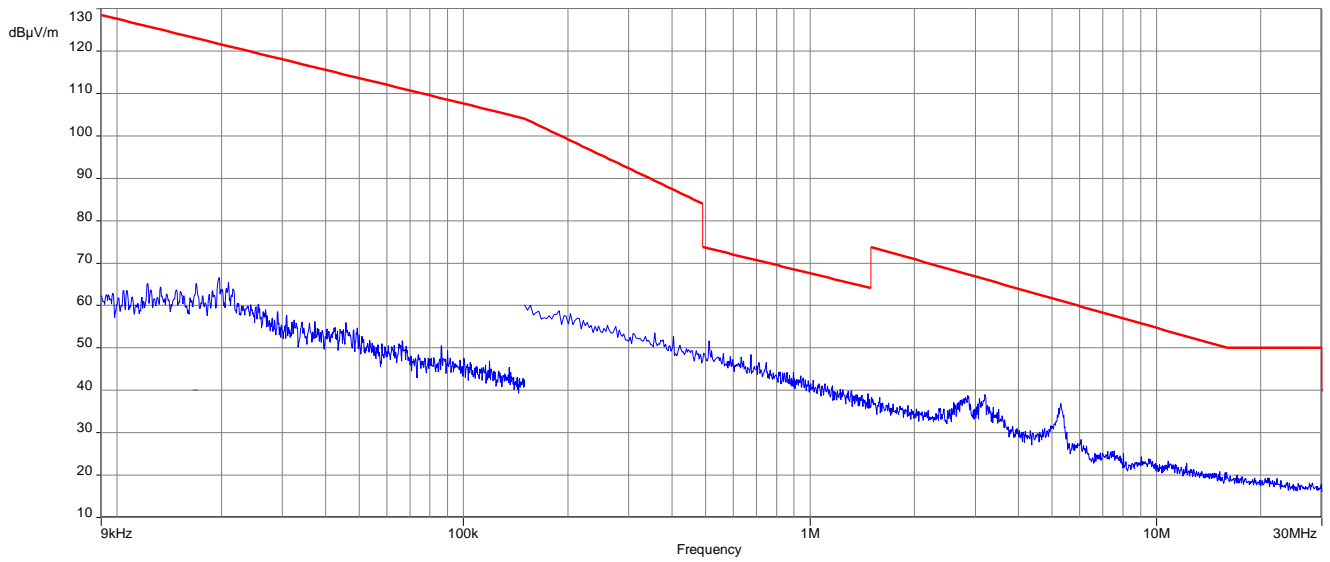

11.10 Spurious emissions radiated 30 MHz to 1 GHz

Description:

Measurement of the radiated spurious emissions and cabinet radiations below 1 GHz.

Measurement:

Measurement parameter	
Detector:	Quasi Peak
Sweep time:	Auto
Resolution bandwidth:	120 kHz
Video bandwidth:	500 kHz
Span:	30 MHz to 1 GHz
Test setup:	See sub clause 6.1 – A
Measurement uncertainty:	See chapter 6

Limits:

TX Spurious Emissions Radiated		
§15.209		
Frequency (MHz)	Field Strength (dBµV/m)	Measurement distance
30 - 88	30.0	10
88 – 216	33.5	10
216 – 960	36.0	10
Above 960	54.0	3
§15.407		
Outside the restricted bands!	-27 dBm / MHz	

Plots: 20 MHz channel bandwidth

Plot 1: 30 MHz to 1 GHz; vertical & horizontal polarization; U-NII-2C; lowest channel

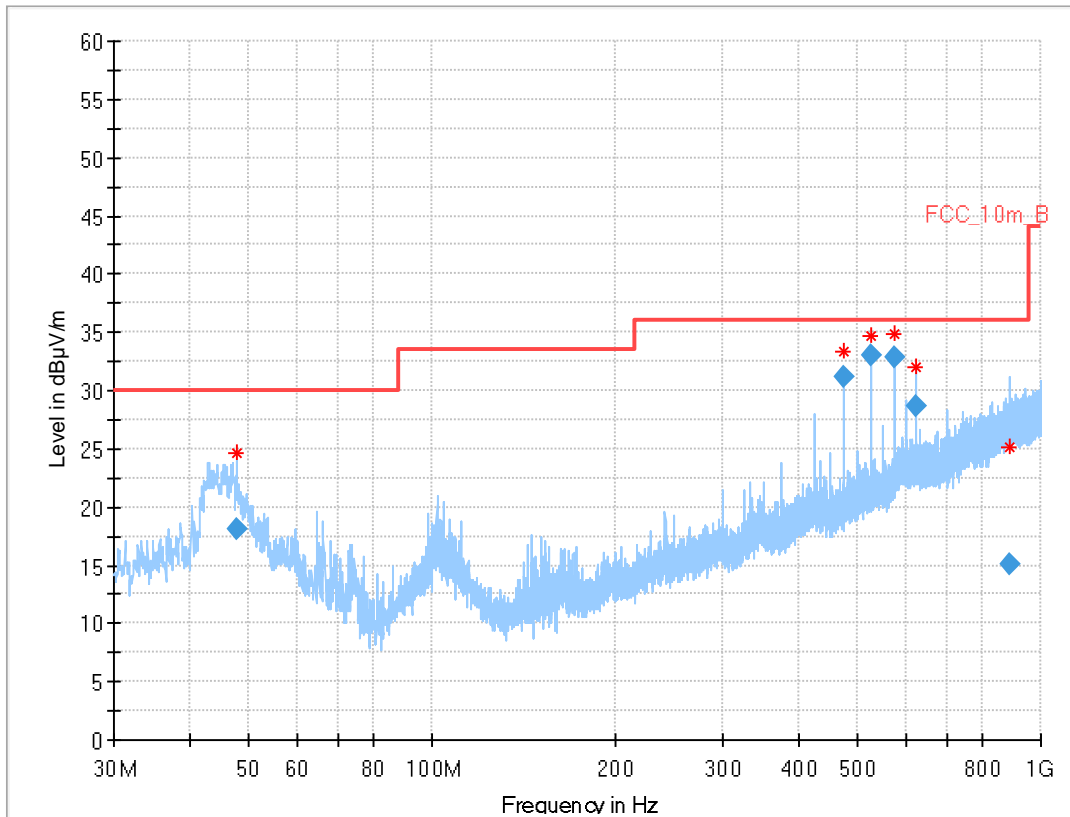

Results:

Frequency (MHz)	QuasiPeak (dBµV/m)	Limit (dBµV/m)	Margin (dB)	Meas. Time (ms)	Bandwidth (kHz)	Height (cm)	Pol	Azimuth (deg)	Corr. (dB)
47.759	18.14	30.0	11.86	1000	120	132.0	V	220.0	14
475.005	31.22	36.0	4.78	1000	120	160.0	H	151.0	18
524.999	32.94	36.0	3.06	1000	120	152.0	H	182.0	19
575.001	32.92	36.0	3.08	1000	120	160.0	H	319.0	19
625.013	28.74	36.0	7.26	1000	120	132.0	H	288.0	21
889.947	15.02	36.0	20.98	1000	120	98.0	H	58.0	24

Plot 2: 30 MHz to 1 GHz; vertical & horizontal polarization; U-NII-2C; middle channel

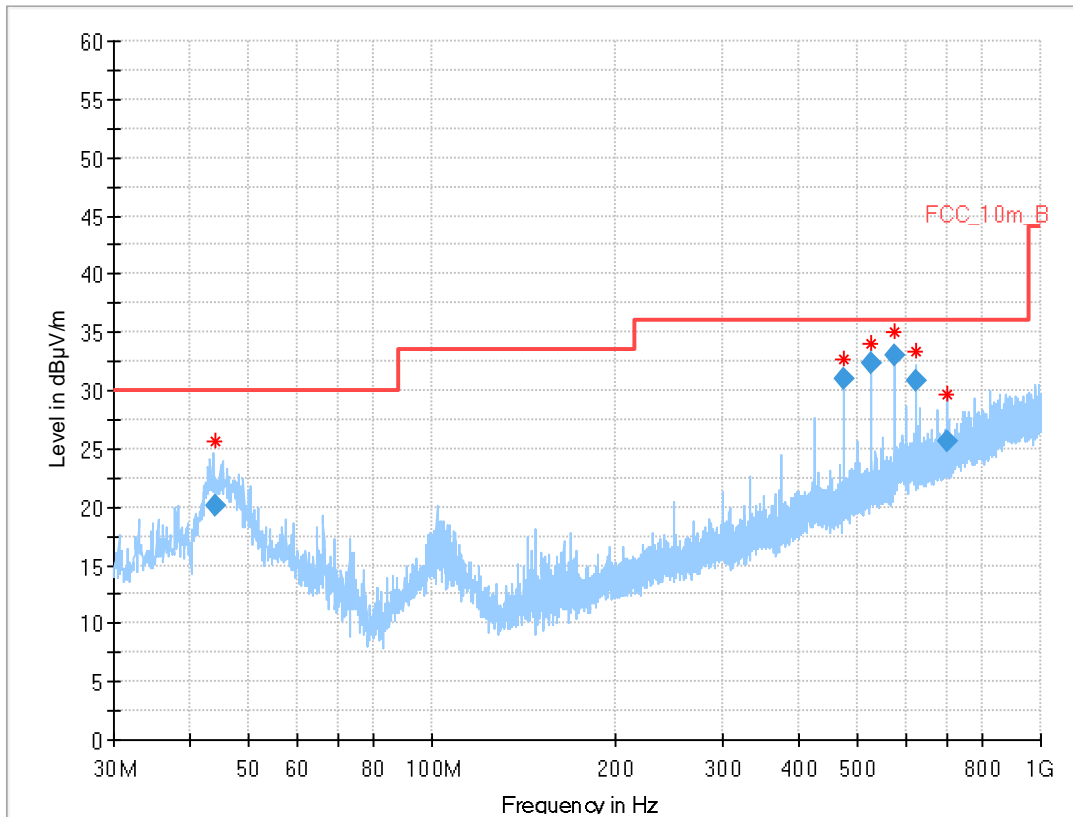

Results:

Frequency (MHz)	QuasiPeak (dBµV/m)	Limit (dBµV/m)	Margin (dB)	Meas. Time (ms)	Bandwidth (kHz)	Height (cm)	Pol	Azimuth (deg)	Corr. (dB)
43.920	20.14	30.0	9.86	1000	120	98.0	V	285.0	14
474.997	30.96	36.0	5.04	1000	120	149.0	H	149.0	18
525.013	32.27	36.0	3.73	1000	120	147.0	H	186.0	19
574.996	33.04	36.0	2.96	1000	120	160.0	H	330.0	19
625.015	30.76	36.0	5.24	1000	120	160.0	H	338.0	21
700.006	25.64	36.0	10.36	1000	120	136.0	H	302.0	21

Plot 3: 30 MHz to 1 GHz; vertical & horizontal polarization; U-NII-2C; highest channel

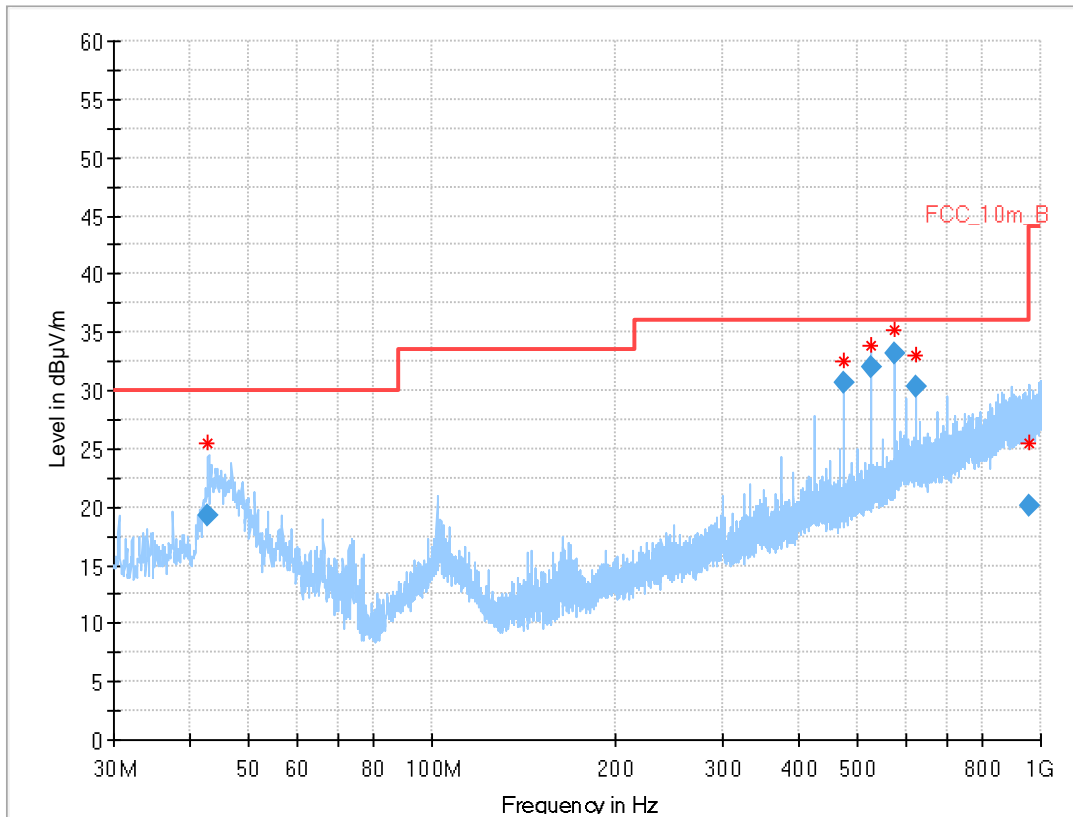

Results:

Frequency (MHz)	QuasiPeak (dBµV/m)	Limit (dBµV/m)	Margin (dB)	Meas. Time (ms)	Bandwidth (kHz)	Height (cm)	Pol	Azimuth (deg)	Corr. (dB)
42.891	19.20	30.0	10.80	1000	120	132.0	V	213.0	14
475.001	30.67	36.0	5.33	1000	120	160.0	H	145.0	18
524.997	32.09	36.0	3.91	1000	120	154.0	H	355.0	19
575.000	33.25	36.0	2.75	1000	120	160.0	H	158.0	19
625.005	30.33	36.0	5.67	1000	120	160.0	H	332.0	21
955.855	20.17	36.0	15.83	1000	120	160.0	V	97.0	24

Plots: 40 MHz channel bandwidth

Plot 1: 30 MHz to 1 GHz; vertical & horizontal polarization; U-NII-2C; lowest channel

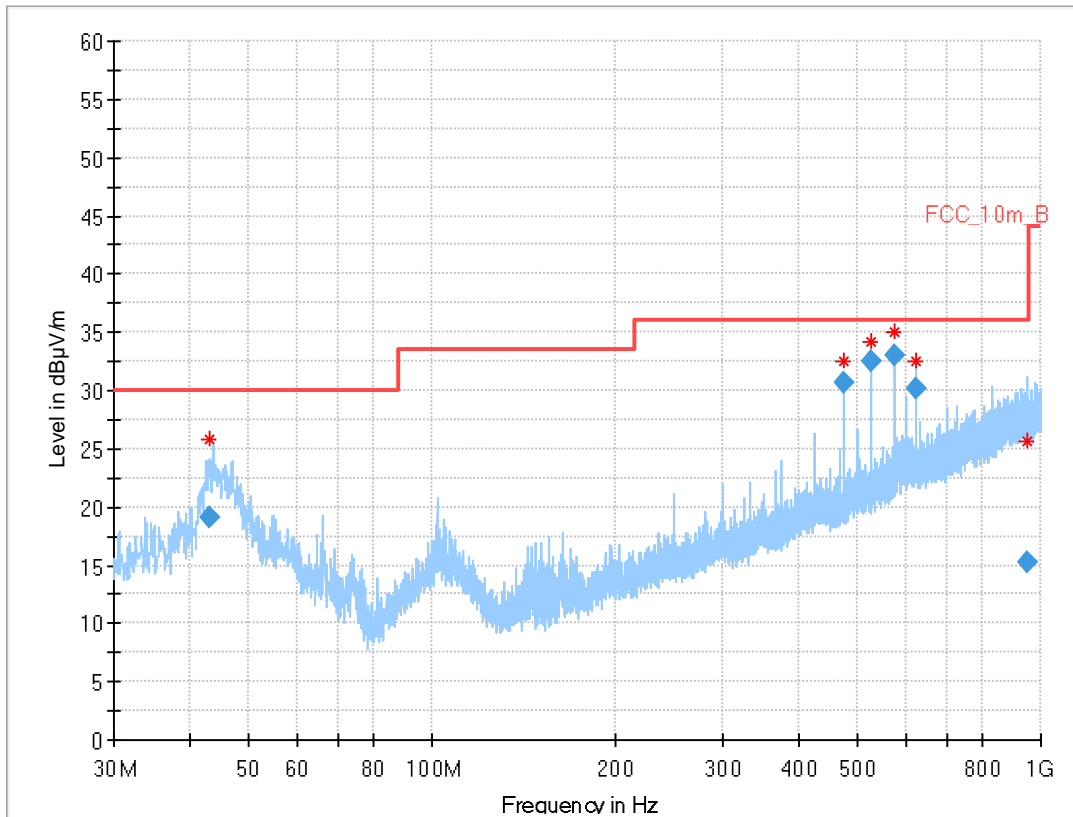

Results:

Frequency (MHz)	QuasiPeak (dBµV/m)	Limit (dBµV/m)	Margin (dB)	Meas. Time (ms)	Bandwidth (kHz)	Height (cm)	Pol	Azimuth (deg)	Corr. (dB)
43.208	19.03	30.0	10.97	1000	120	160.0	V	174.0	14
475.002	30.65	36.0	5.35	1000	120	160.0	H	269.0	18
524.990	32.49	36.0	3.51	1000	120	153.0	H	168.0	19
575.006	33.01	36.0	2.99	1000	120	160.0	H	329.0	19
625.006	30.14	36.0	5.86	1000	120	139.0	H	311.0	21
948.870	15.17	36.0	20.83	1000	120	153.0	V	355.0	24

Plot 2: 30 MHz to 1 GHz; vertical & horizontal polarization; U-NII-2C; middle channel

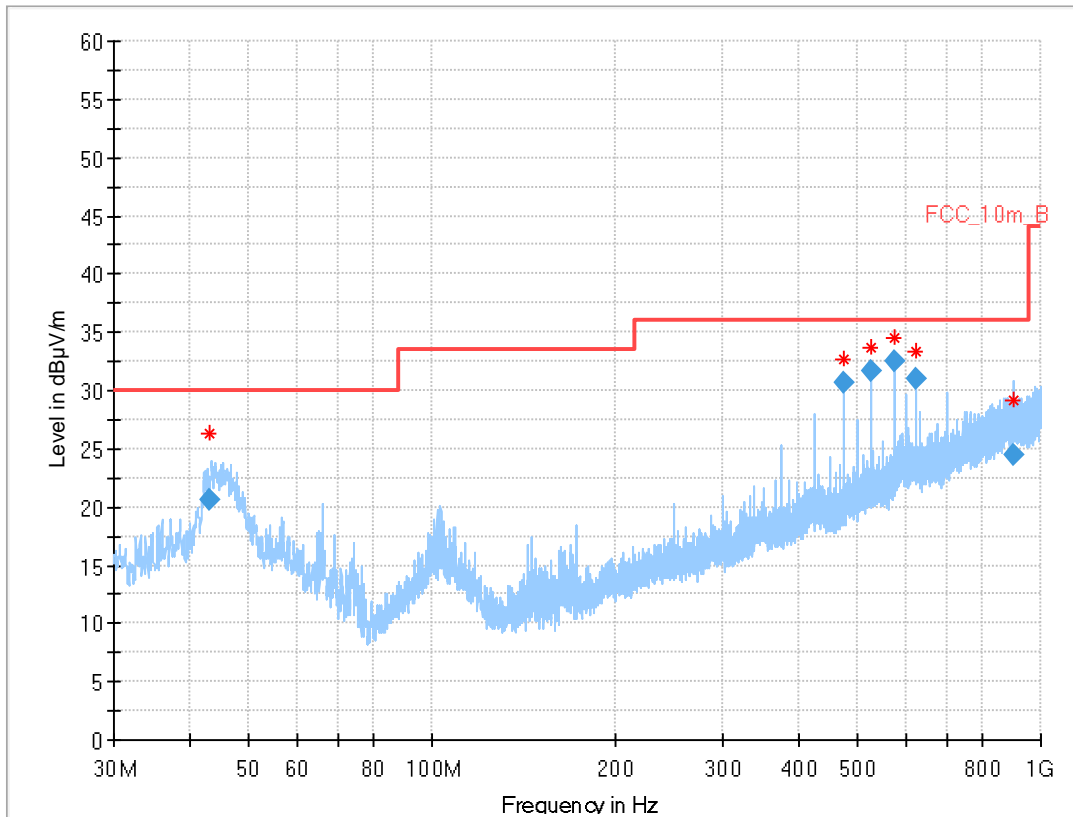

Results:

Frequency (MHz)	QuasiPeak (dBµV/m)	Limit (dBµV/m)	Margin (dB)	Meas. Time (ms)	Bandwidth (kHz)	Height (cm)	Pol	Azimuth (deg)	Corr. (dB)
43.084	20.65	30.0	9.35	1000	120	102.0	V	345.0	14
475.014	30.70	36.0	5.30	1000	120	139.0	H	167.0	18
524.997	31.62	36.0	4.38	1000	120	152.0	H	305.0	19
574.994	32.55	36.0	3.45	1000	120	160.0	H	168.0	19
624.996	30.95	36.0	5.05	1000	120	160.0	H	338.0	21
900.020	24.41	36.0	11.59	1000	120	101.0	H	183.0	24

Plot 3: 30 MHz to 1 GHz; vertical & horizontal polarization; U-NII-2C; highest channel

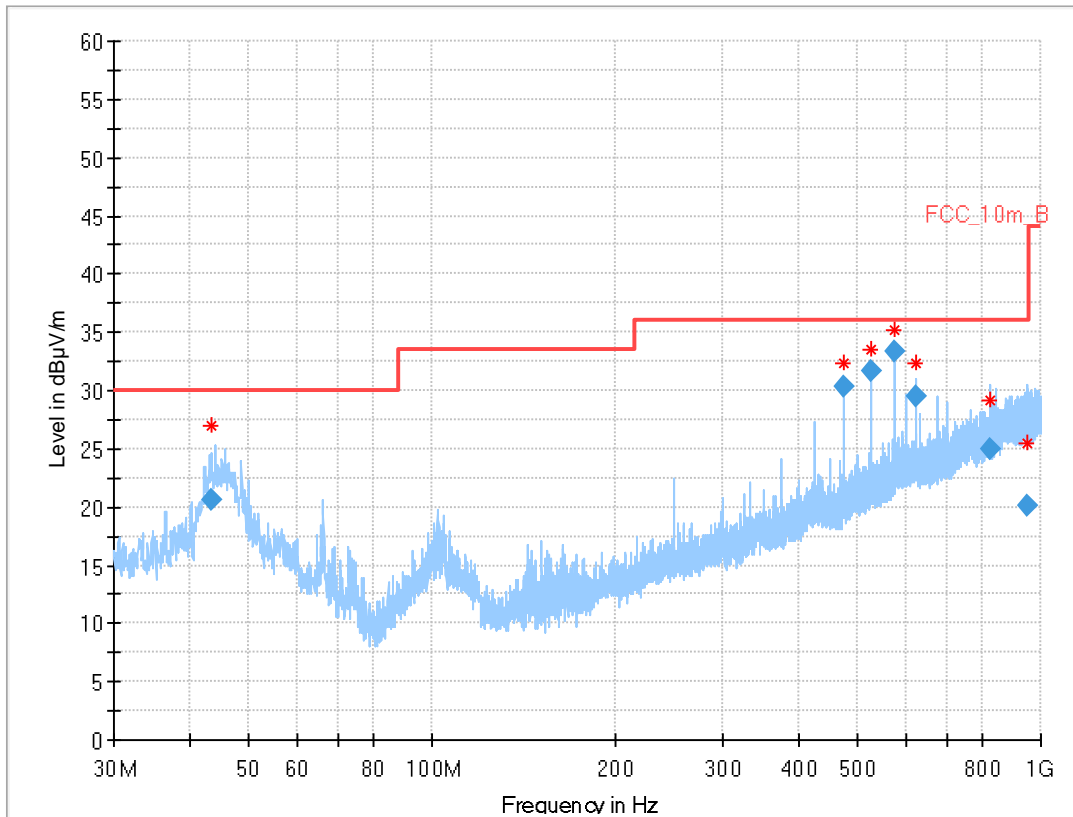

Results:

Frequency (MHz)	QuasiPeak (dBµV/m)	Limit (dBµV/m)	Margin (dB)	Meas. Time (ms)	Bandwidth (kHz)	Height (cm)	Pol	Azimuth (deg)	Corr. (dB)
43.533	20.62	30.0	9.38	1000	120	105.0	V	285.0	14
474.999	30.32	36.0	5.68	1000	120	160.0	H	143.0	18
525.007	31.72	36.0	4.28	1000	120	147.0	H	347.0	19
575.002	33.29	36.0	2.71	1000	120	160.0	H	153.0	19
624.997	29.57	36.0	6.43	1000	120	160.0	H	312.0	21
825.017	24.99	36.0	11.01	1000	120	111.0	H	272.0	23
947.240	20.04	36.0	15.96	1000	120	160.0	H	115.0	24

11.11 Spurious emissions radiated 1 GHz to 40 GHz

Description:

Measurement of the radiated spurious emissions and cabinet radiations from 1 GHz to 40 GHz.

Measurement:

Measurement parameter	
Detector:	Quasi Peak below 1 GHz (alternative Peak) Peak above 1 GHz / RMS
Sweep time:	Auto
Resolution bandwidth:	1 MHz
Video bandwidth:	3 MHz
Span:	1 GHz to 40 GHz
Trace mode:	Max Hold / Average with 100 counts + 20 log (1 / X) for duty cycle lower than 100 %
Test setup:	See sub clause 6.1 – A See sub clause 6.2 – B See sub clause 6.3 – A
Measurement uncertainty:	See chapter 6

Limits:

TX Spurious Emissions Radiated		
§15.209		
Frequency (MHz)	Field Strength (dBµV/m)	Measurement distance
Above 960	54.0	3
§15.407		
Outside the restricted bands!	-27 dBm / MHz	

Results: 20 MHz channel bandwidth

TX Spurious Emissions Radiated [dBµV/m] / dBm								
U-NII-2C (5470 MHz to 5725 MHz)								
Lowest channel			Middle channel			Highest channel		
F [MHz]	Detector	Level [dBµV/m]	F [MHz]	Detector	Level [dBµV/m]	F [MHz]	Detector	Level [dBµV/m]
1025	Peak	42.0	1025	Peak	42.0	1025	Peak	42.0
	AVG	37.1		AVG	37.1		AVG	37.1
11000	Peak	60.4	11205	Peak	62.5	11400	Peak	61.9
	AVG	47.9		AVG	50.3		AVG	50.3
For emissions above 18 GHz please take look at the plots.			For emissions above 18 GHz please take look at the plots.			For emissions above 18 GHz please take look at the plots.		

Results: 40 MHz channel bandwidth

TX Spurious Emissions Radiated [dBµV/m] / dBm								
U-NII-2C (5470 MHz to 5725 MHz)								
Lowest channel			Middle channel			Highest channel		
F [MHz]	Detector	Level [dBµV/m]	F [MHz]	Detector	Level [dBµV/m]	F [MHz]	Detector	Level [dBµV/m]
1025	Peak	42.0	1025	Peak	42.0	1025	Peak	42.0
	AVG	37.1		AVG	37.1		AVG	37.1
	Peak		7453	Peak	50.9	7560	Peak	51.1
	AVG			AVG	45.8		AVG	46.2
For emissions above 18 GHz please take look at the plots.			For emissions above 18 GHz please take look at the plots.			For emissions above 18 GHz please take look at the plots.		

Plots: 20 MHz channel bandwidth

Plot 1: 1 GHz to 18 GHz; vertical & horizontal polarization; U-NII-2C; lowest channel

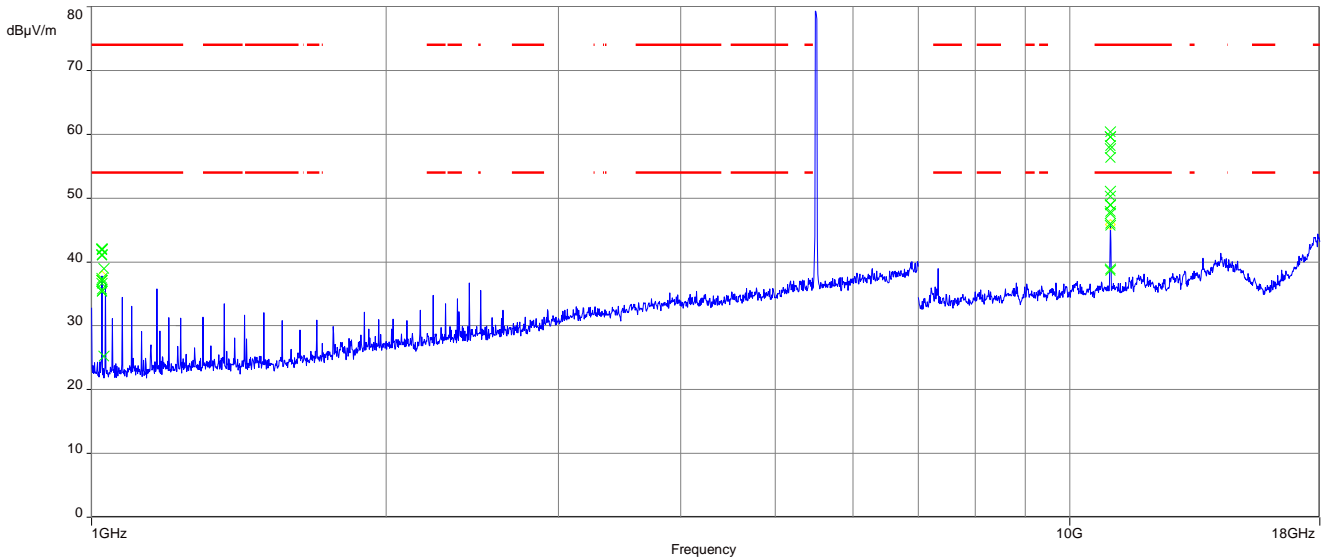

Plot 2: 18 GHz to 26 GHz; vertical & horizontal polarization; U-NII-2C; lowest channel

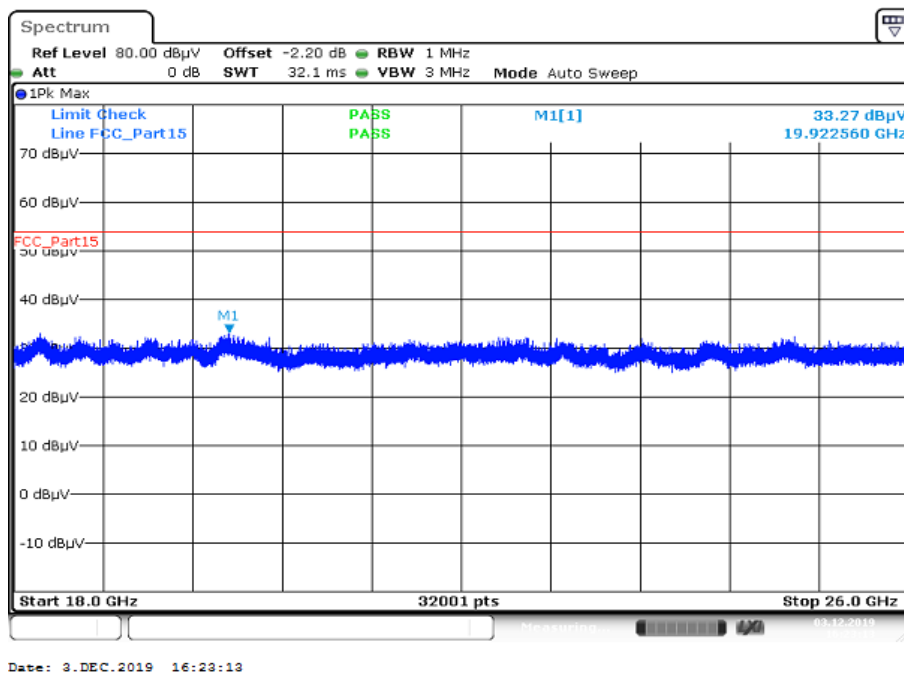

Plot 3: 26 GHz to 40 GHz; vertical & horizontal polarization; U-NII-2C; lowest channel

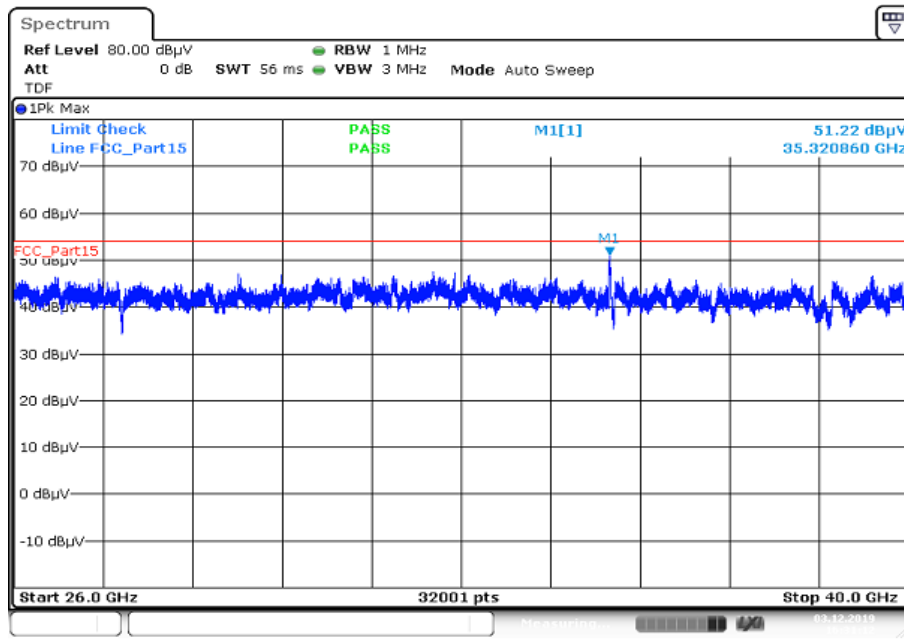

Plot 4: 1 GHz to 18 GHz; vertical & horizontal polarization; U-NII-2C; middle channel

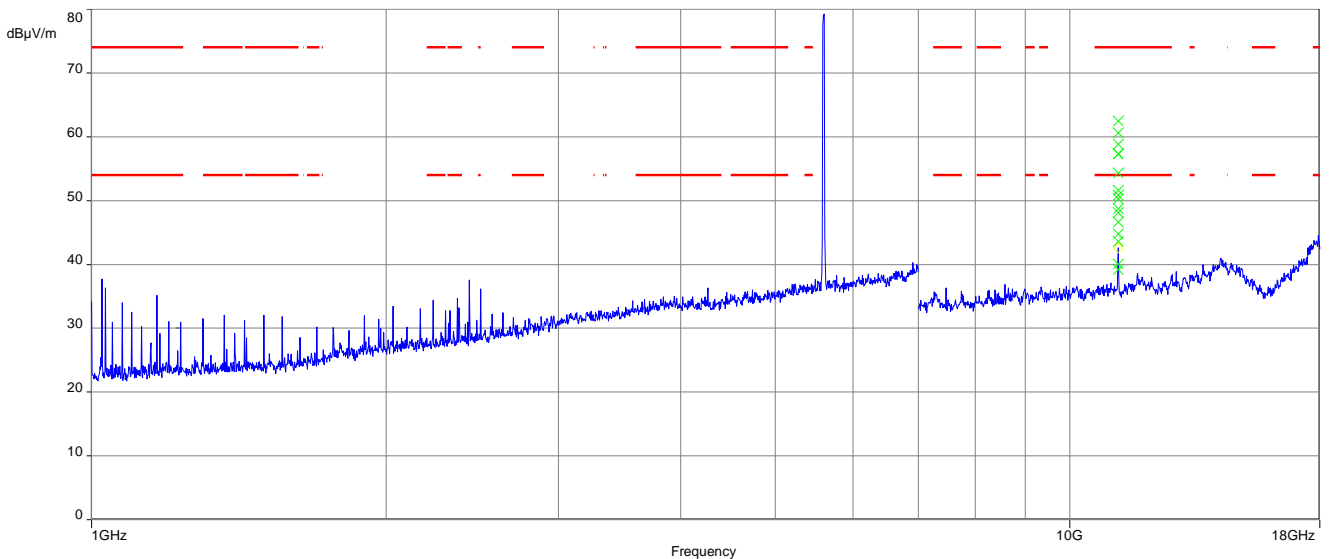

Plot 5: 18 GHz to 26 GHz; vertical & horizontal polarization; U-NII-2C; middle channel

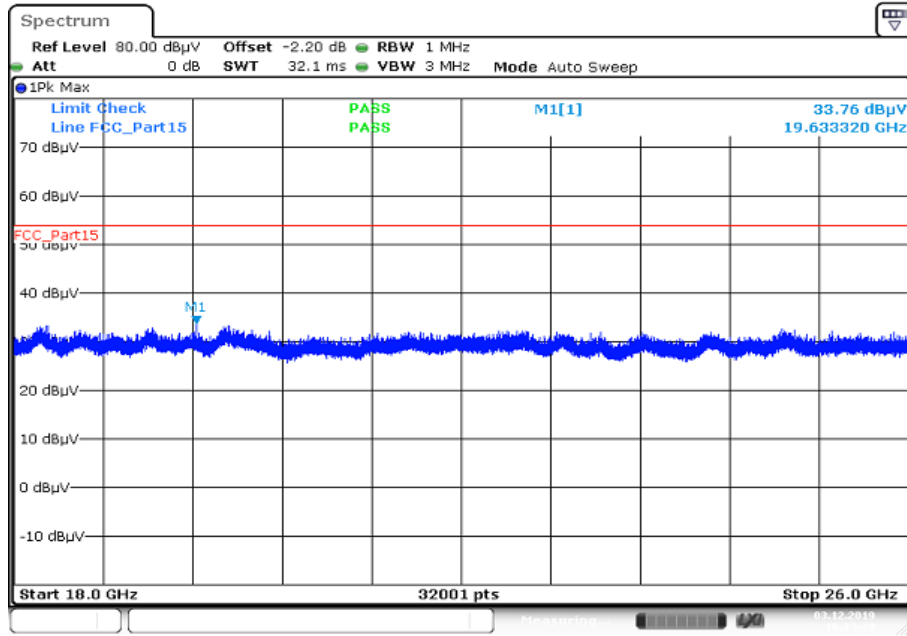

Date: 3.DEC.2019 16:23:38

Plot 6: 26 GHz to 40 GHz; vertical & horizontal polarization; U-NII-2C; middle channel

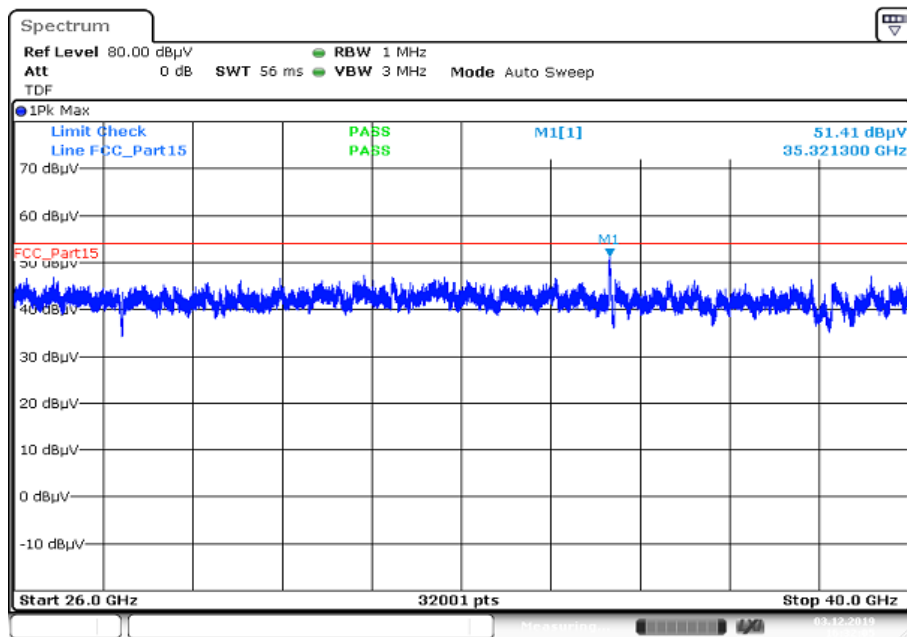

Date: 3.DEC.2019 16:32:05

Plot 7: 1 GHz to 18 GHz; vertical & horizontal polarization; U-NII-2C; highest channel

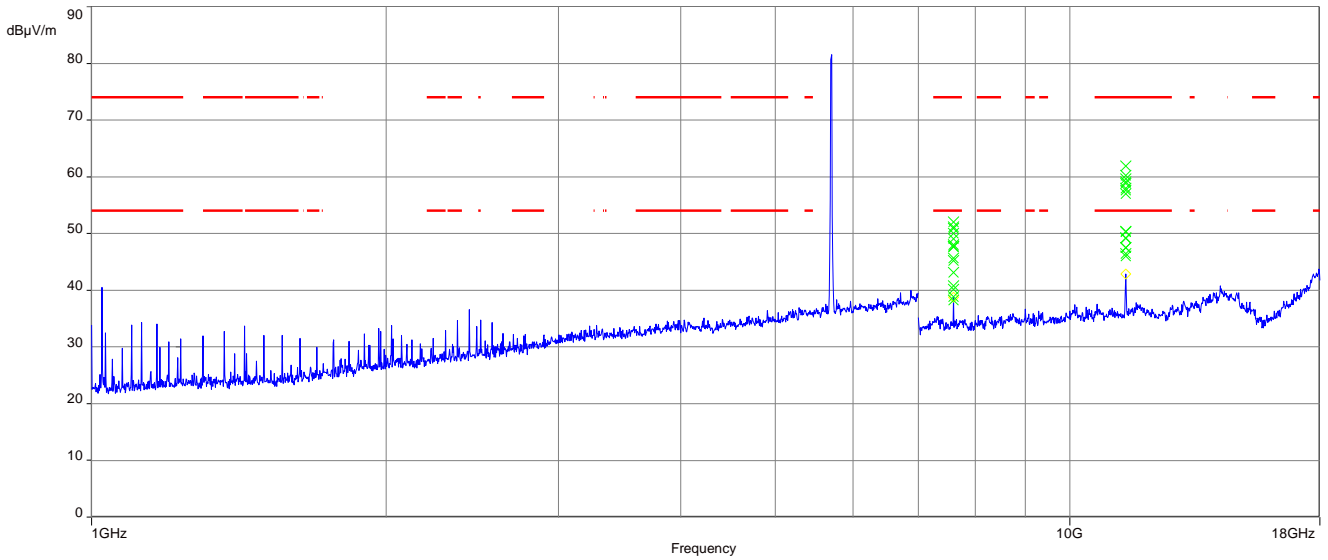

Plot 8: 18 GHz to 26 GHz; vertical & horizontal polarization; U-NII-2C; highest channel

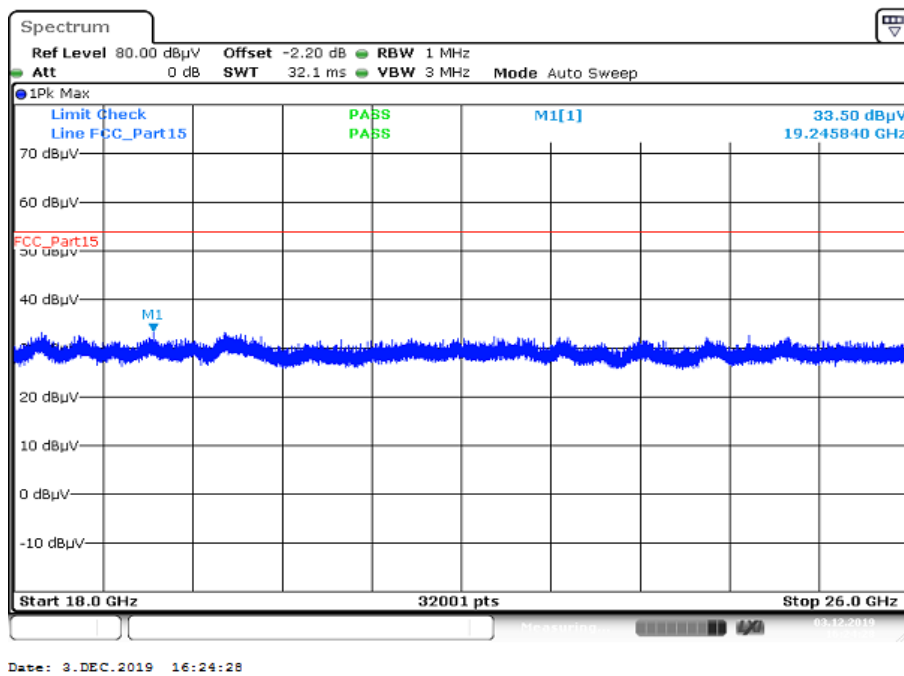

Plot 9: 26 GHz to 40 GHz; vertical & horizontal polarization; U-NII-2C; highest channel

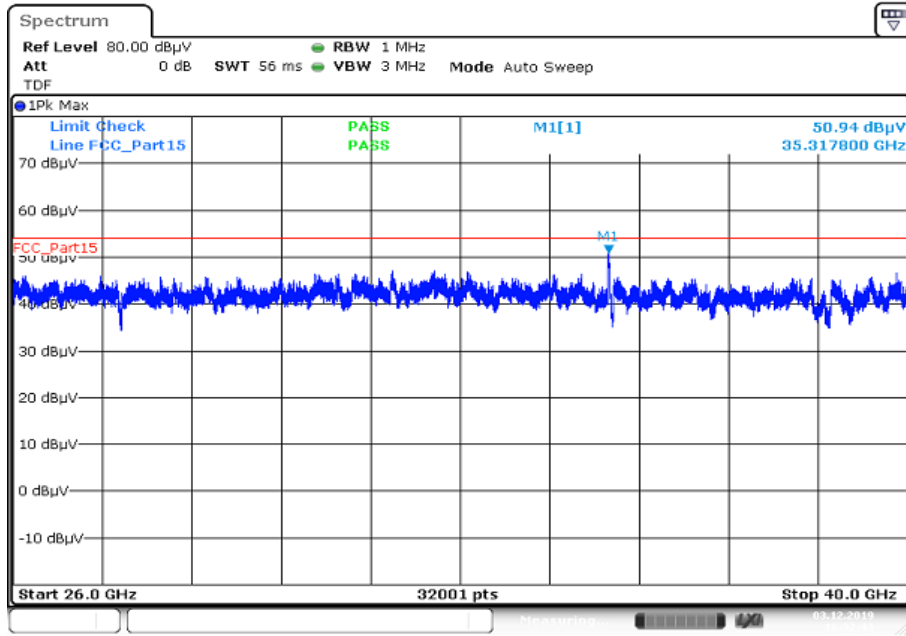

Plots: 40 MHz channel bandwidth

Plot 1: 1 GHz to 18 GHz; vertical & horizontal polarization; U-NII-2C; lowest channel

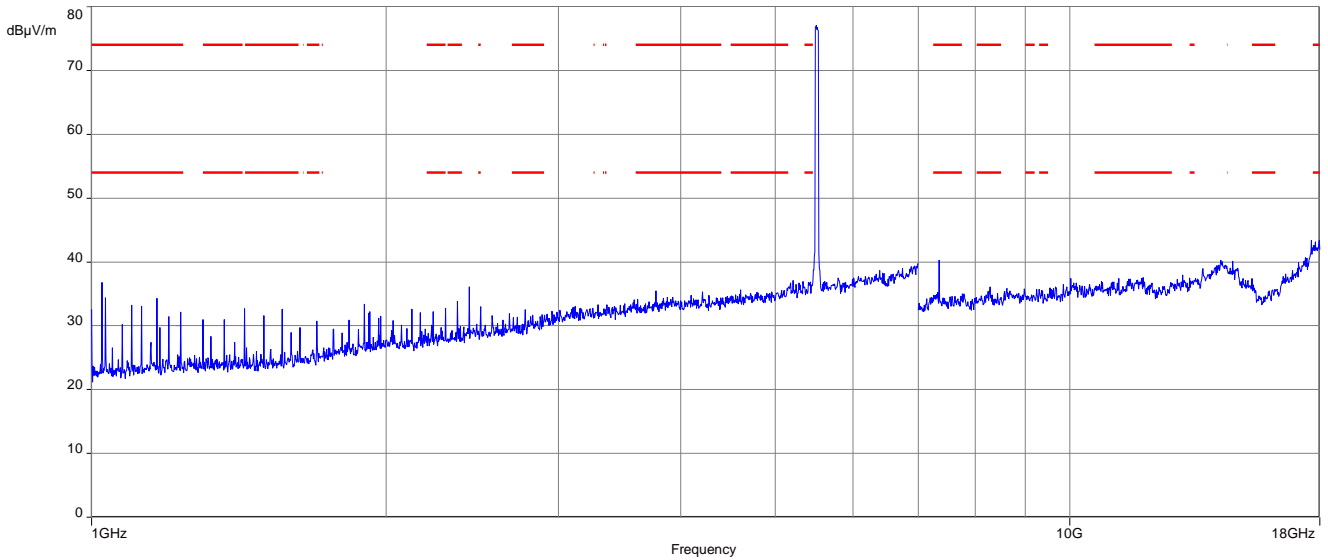

Plot 2: 18 GHz to 26 GHz; vertical & horizontal polarization; U-NII-2C; lowest channel

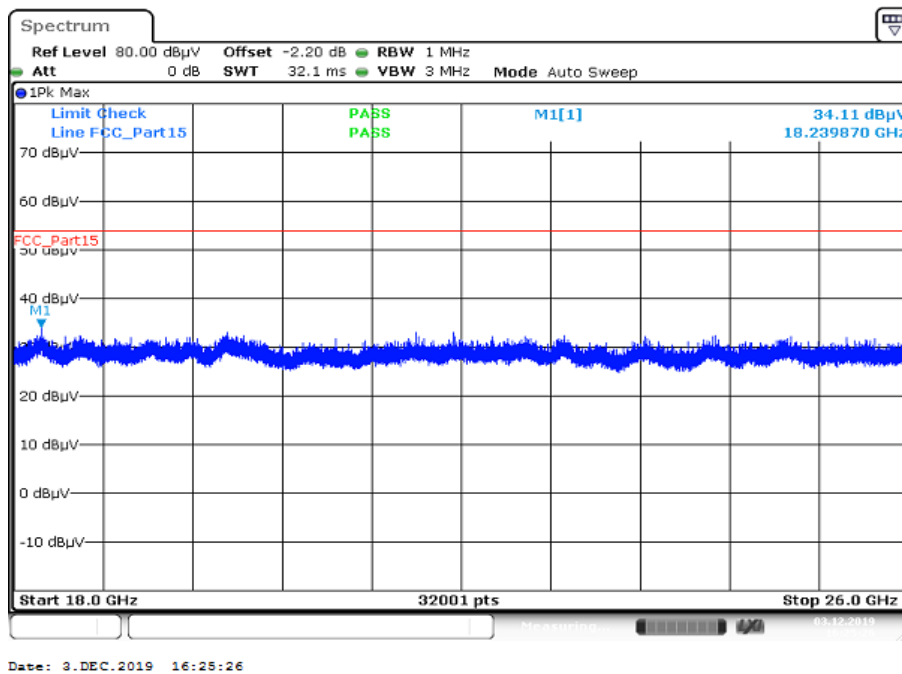

Plot 3: 26 GHz to 40 GHz; vertical & horizontal polarization; U-NII-2C; lowest channel

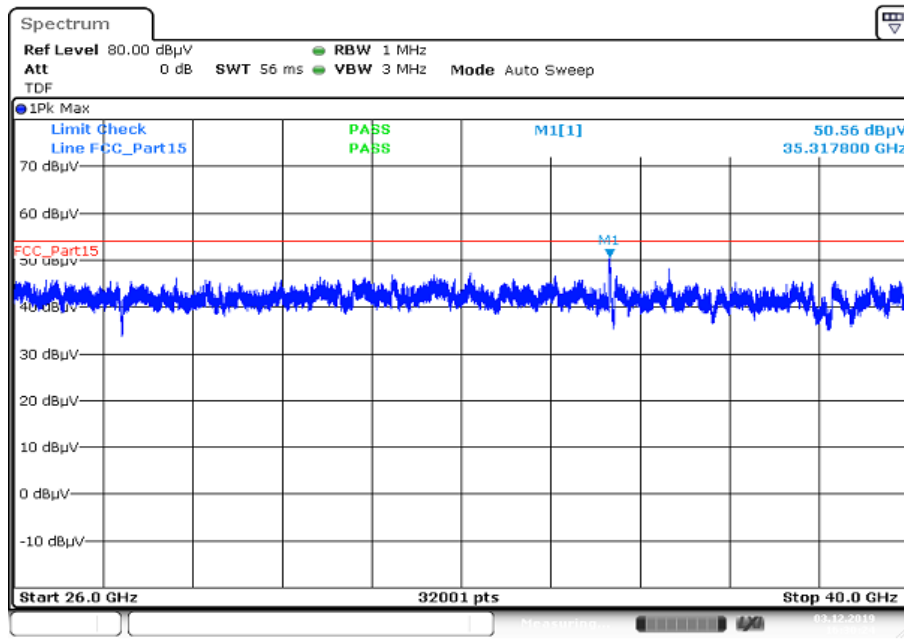

Plot 4: 1 GHz to 18 GHz; vertical & horizontal polarization; U-NII-2C; middle channel

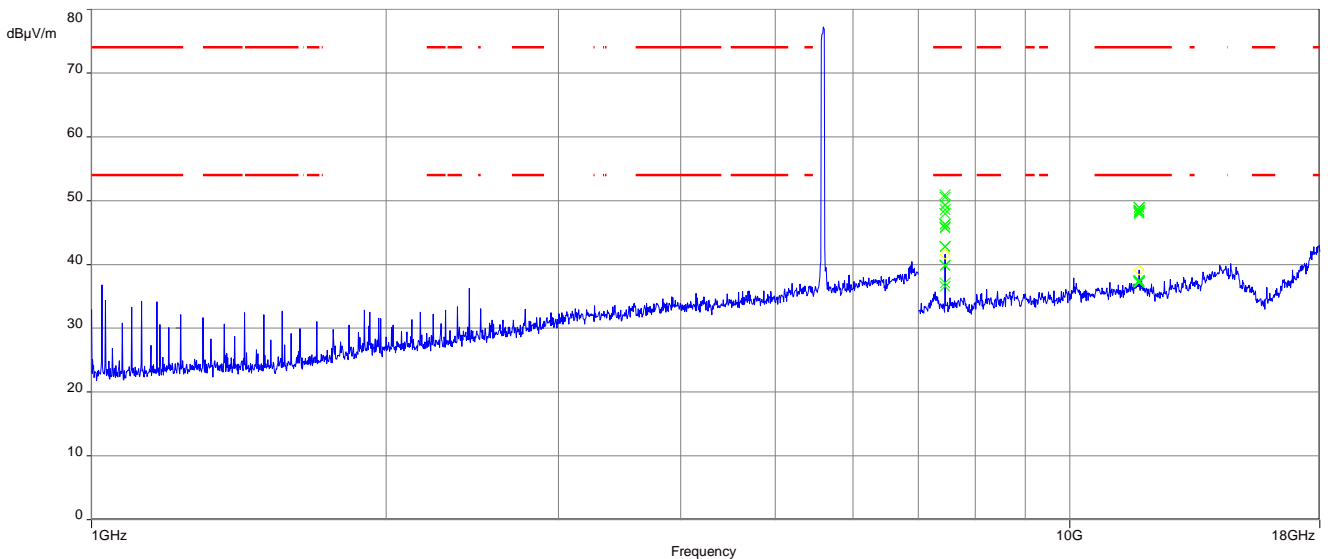

Plot 5: 18 GHz to 26 GHz; vertical & horizontal polarization; U-NII-2C; middle channel

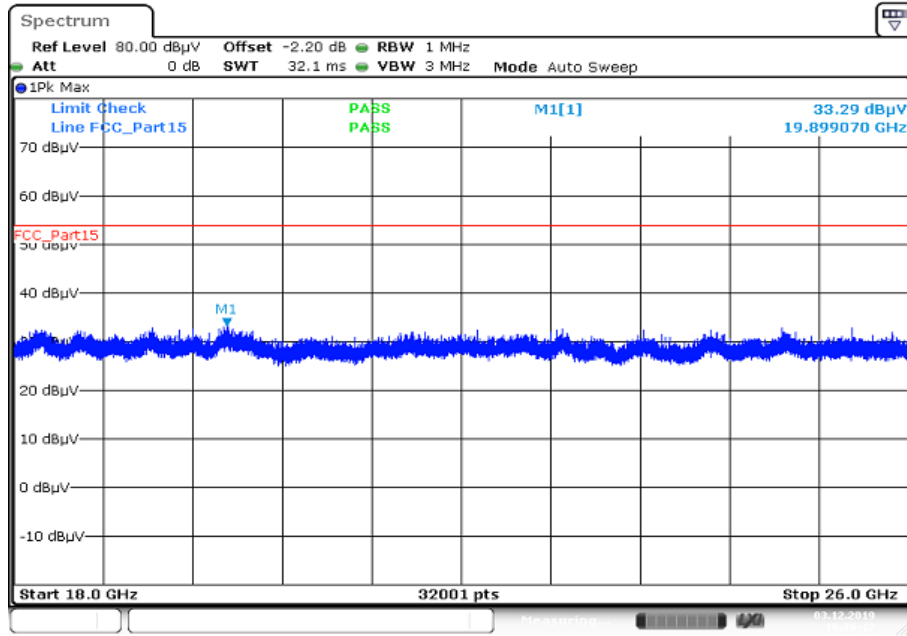

Date: 3.DEC.2019 16:26:12

Plot 6: 26 GHz to 40 GHz; vertical & horizontal polarization; U-NII-2C; middle channel

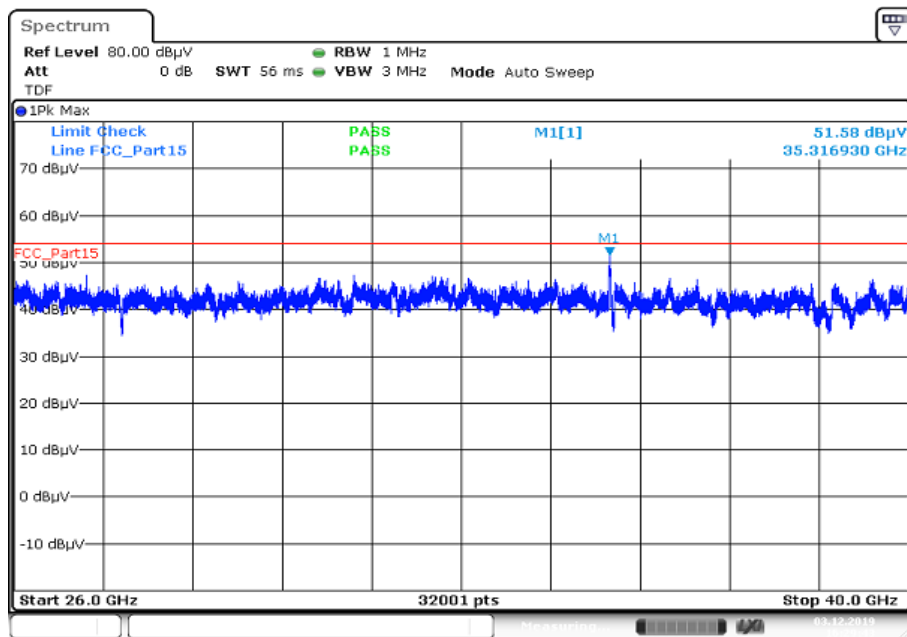

Date: 3.DEC.2019 16:29:43

Plot 7: 1 GHz to 18 GHz; vertical & horizontal polarization; U-NII-2C; highest channel

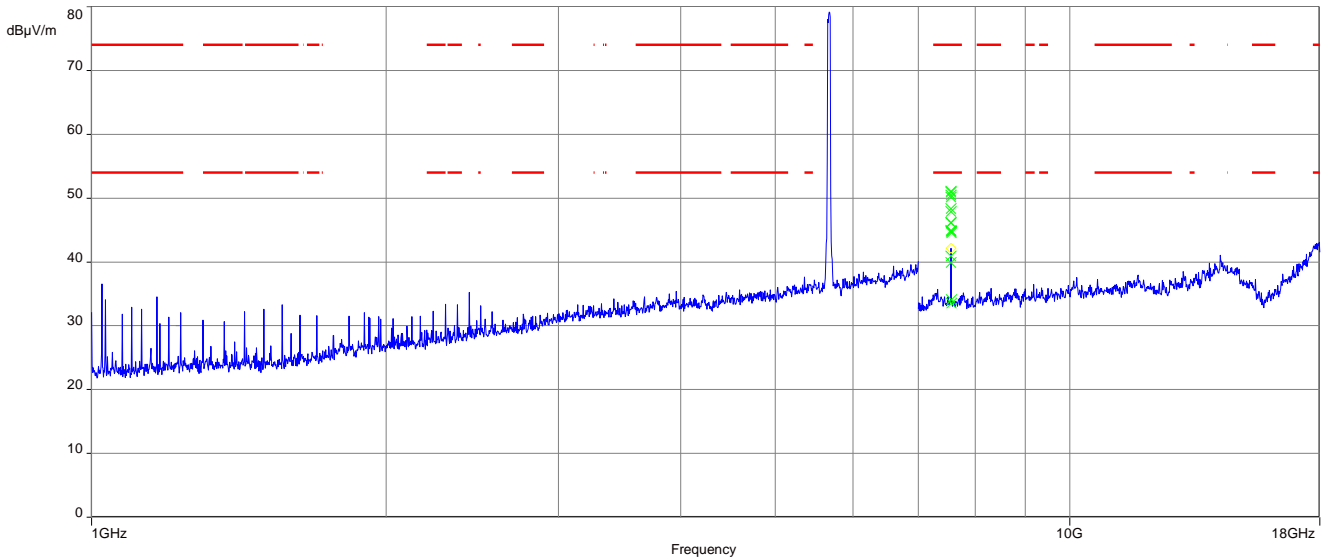

Plot 8: 18 GHz to 26 GHz; vertical & horizontal polarization; U-NII-2C; highest channel

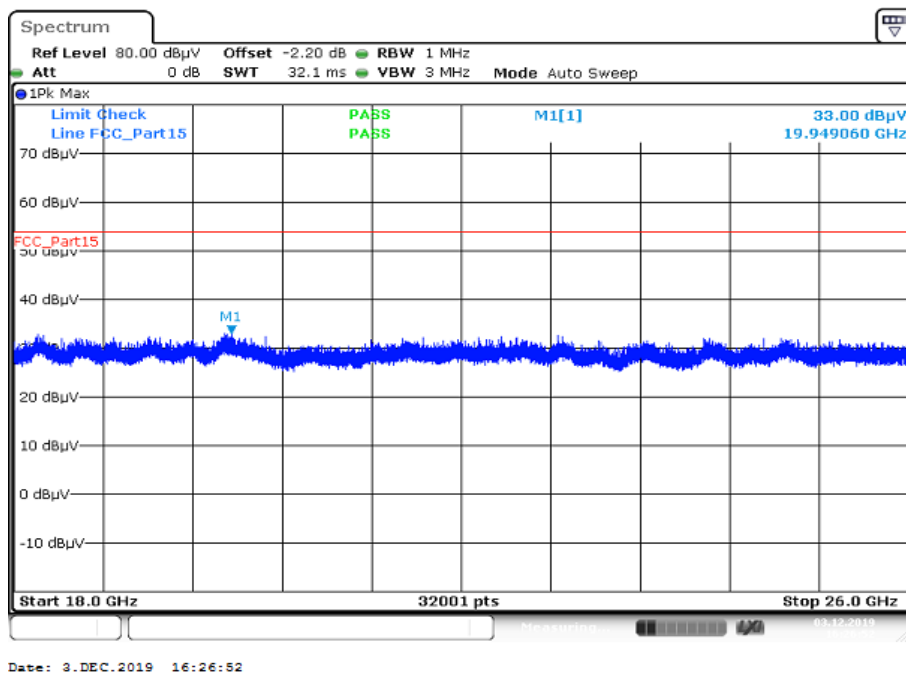

Plot 9: 26 GHz to 40 GHz; vertical & horizontal polarization; U-NII-2C; highest channel

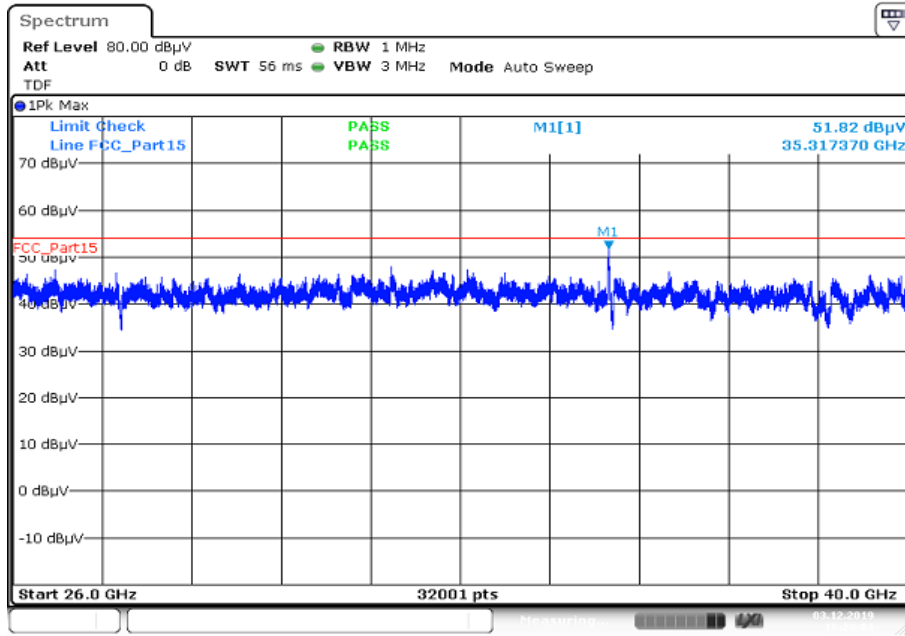

Date: 3.DEC.2019 16:29:03

11.12 Spurious emissions conducted < 30 MHz

Description:

Measurement of the conducted spurious emissions in transmit mode below 30 MHz. The EUT is set to middle channel. If critical peaks are found the lowest channel and the highest channel will be measured too. Both power lines, phase and neutral line, are measured. Found peaks are re-measured with average and quasi peak detection to show compliance to the limits.

Measurement:

Measurement parameter	
Detector:	Peak - Quasi Peak / Average
Sweep time:	Auto
Video bandwidth:	9 kHz
Resolution bandwidth:	100 kHz
Span:	150 kHz to 30 MHz
Trace mode:	Max Hold
Test setup:	See sub clause 6.5 – A
Measurement uncertainty:	See chapter 8

Limits:

Spurious Emissions Conducted < 30 MHz		
Frequency (MHz)	Quasi-Peak (dBµV/m)	Average (dBµV/m)
0.15 – 0.5	66 to 56*	56 to 46*
0.5 – 5	56	46
5 – 30.0	60	50

*Decreases with the logarithm of the frequency

Results:

Spurious Emissions Conducted < 30 MHz [dBµV/m]		
F [MHz]	Detector	Level [dBµV/m]
All detected emissions are more than 20 dB below the limit.		

Plots:

Plot 1: 150 kHz to 30 MHz, phase line

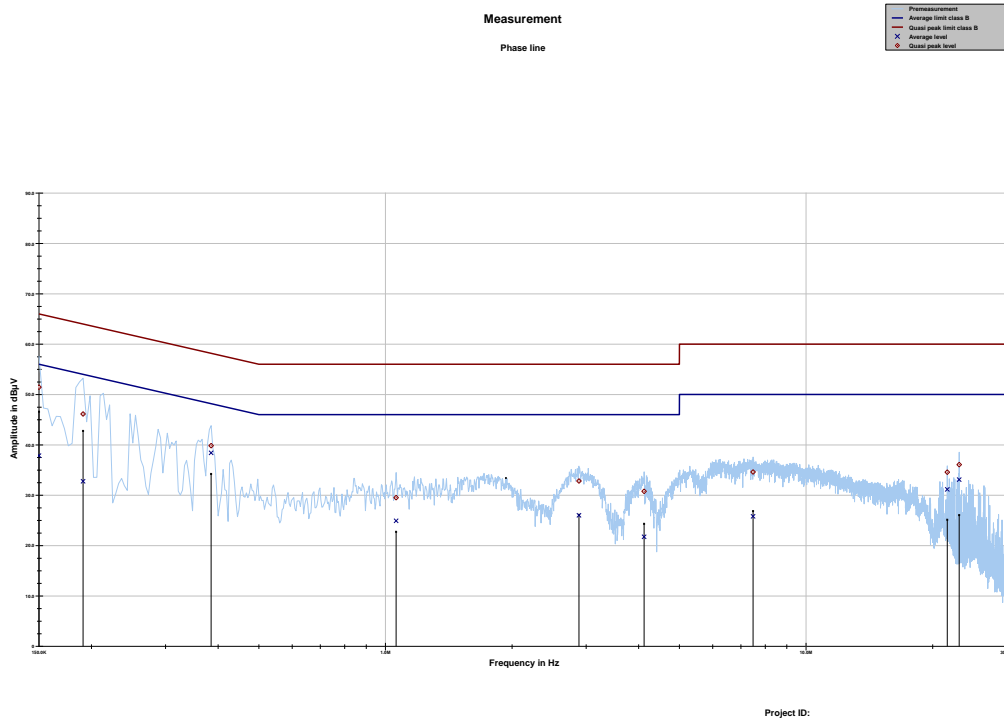

Final results:

Frequency	Quasi peak level	Margin quasi peak	Limit QP	Average level	Margin average	Limit AV
MHz	dBµV	dB	dBµV	dBµV	dB	dBµV
0.150000	51.44	14.56	66.000	37.85	18.15	56.000
0.191044	46.12	17.87	63.991	32.76	22.07	54.827
0.385069	39.84	18.33	58.169	38.42	10.87	49.284
1.060425	29.52	26.48	56.000	24.91	21.09	46.000
2.885006	32.81	23.19	56.000	26.01	19.99	46.000
4.120050	30.76	25.24	56.000	21.75	24.25	46.000
7.481906	34.60	25.40	60.000	25.80	24.20	50.000
21.664388	34.56	25.44	60.000	31.15	18.85	50.000
23.130769	36.07	23.93	60.000	33.10	16.90	50.000

Plot 2: 150 kHz to 30 MHz, neutral line

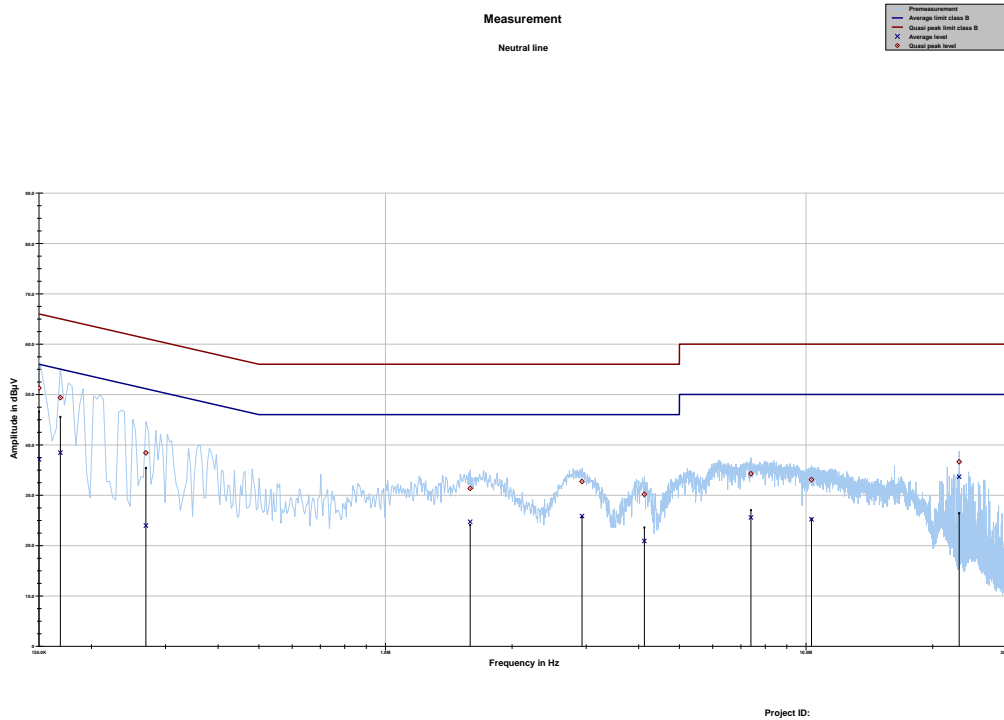

Final results:

Frequency	Quasi peak level	Margin quasi peak	Limit QP	Average level	Margin average	Limit AV
MHz	dBµV	dB	dBµV	dBµV	dB	dBµV
0.150000	51.27	14.73	66.000	37.10	18.90	56.000
0.168656	49.37	15.66	65.026	38.44	17.02	55.467
0.269400	38.41	22.73	61.136	23.98	28.61	52.589
1.590262	31.36	24.64	56.000	24.73	21.27	46.000
2.933512	32.71	23.29	56.000	25.87	20.13	46.000
4.127512	30.20	25.80	56.000	20.90	25.10	46.000
7.396088	34.26	25.74	60.000	25.59	24.41	50.000
10.302731	33.10	26.90	60.000	25.22	24.78	50.000
23.130769	36.63	23.37	60.000	33.67	16.33	50.000

Annex A Glossary

EUT	Equipment under test
DUT	Device under test
UUT	Unit under test
GUE	GNSS User Equipment
ETSI	European Telecommunications Standards Institute
EN	European Standard
FCC	Federal Communications Commission
FCC ID	Company Identifier at FCC
IC	Industry Canada
PMN	Product marketing name
HMN	Host marketing name
HVIN	Hardware version identification number
FVIN	Firmware version identification number
EMC	Electromagnetic Compatibility
HW	Hardware
SW	Software
Inv. No.	Inventory number
S/N or SN	Serial number
C	Compliant
NC	Not compliant
NA	Not applicable
NP	Not performed
PP	Positive peak
QP	Quasi peak
AVG	Average
OC	Operating channel
OCW	Operating channel bandwidth
OBW	Occupied bandwidth
OOB	Out of band
DFS	Dynamic frequency selection
CAC	Channel availability check
OP	Occupancy period
NOP	Non occupancy period
DC	Duty cycle
PER	Packet error rate
CW	Clean wave
MC	Modulated carrier
WLAN	Wireless local area network
RLAN	Radio local area network
DSSS	Dynamic sequence spread spectrum
OFDM	Orthogonal frequency division multiplexing
FHSS	Frequency hopping spread spectrum
GNSS	Global Navigation Satellite System
C/N₀	Carrier to noise-density ratio, expressed in dB-Hz

Annex B Document history

Version	Applied changes	Date of release
-/-	Initial release	2019-12-11

Annex C Accreditation Certificate – D-PL-12076-01-04

first page	last page
 <p>The first page of the accreditation certificate includes the DAkkS logo, the name 'Deutsche Akkreditierungsstelle GmbH', and states it is entrusted according to Section 8 subsection 1 of the AkkStelleG. It identifies the laboratory as 'CTC advanced GmbH' located at 'Untertürkheimer Straße 6-10, 66117 Saarbrücken'. The certificate is for 'Telecommunication (TC) and Electromagnetic Compatibility (EMC) for Canadian Standards'. It is signed by Dipl.-Biol. Uwe Zimmermann, Head of Division, on 11.01.2019 in Frankfurt am Main.</p>	 <p>The last page lists three office locations: Berlin (Spittelmarkt 10), Frankfurt am Main (Europa-Allee 52), and Braunschweig (Bundesallee 100). It contains legal disclaimers regarding the publication of extracts and the scope of accreditation, and provides website links for EA, ILAC, and IAF.</p>

Note: The current certificate annex is published on the website (link see below) of the Accreditation Body DAkkS or may be received by CTC advanced GmbH on request

<https://www.dakks.de/as/ast/d/D-PL-12076-01-04.pdf>

Annex D Accreditation Certificate – D-PL-12076-01-05

first page	last page
 <p>Deutsche Akkreditierungsstelle GmbH</p> <p>Entrusted according to Section 8 subsection 1 AkkStelleG in connection with Section 1 subsection 1 AkkStelleGBV Signatory to the Multilateral Agreements of EA, ILAC and IAF for Mutual Recognition</p> <p>Accreditation </p> <p>The Deutsche Akkreditierungsstelle GmbH attests that the testing laboratory CTC advanced GmbH Untertürkheimer Straße 6-10, 66117 Saarbrücken is competent under the terms of DIN EN ISO/IEC 17025:2005 to carry out tests in the following fields: Telecommunication (FCC Requirements)</p> <p>The accreditation certificate shall only apply in connection with the notice of accreditation of 11.01.2019 with the accreditation number D-PL-12076-01 and is valid until 21.04.2021. It comprises the cover sheet, the reverse side of the cover sheet and the following annex with a total of 5 pages.</p> <p>Registration number of the certificate: D-PL-12076-01-05</p> <p>Frankfurt am Main, 11.01.2019  Head of Division</p> <p><small>See notes on final</small></p>	<p>Deutsche Akkreditierungsstelle GmbH</p> <p>Office Berlin Spittelmarkt 10 10117 Berlin</p> <p>Office Frankfurt am Main Europa-Allee 52 60327 Frankfurt am Main</p> <p>Office Braunschweig Bundesallee 100 38116 Braunschweig</p> <p>The publication of extracts of the accreditation certificate is subject to the prior written approval by Deutsche Akkreditierungsstelle GmbH (DAkKS). Exempted is the unchanged form of separate disseminations of the cover sheet by the conformity assessment body mentioned overleaf.</p> <p>No impression shall be made that the accreditation also extends to fields beyond the scope of accreditation attested by DAkKS.</p> <p>The accreditation was granted pursuant to the Act on the Accreditation Body (AkkStelleG) of 31 July 2009 (Federal Law Gazette I p. 2625) and the Regulation (EC) No 765/2008 of the European Parliament and of the Council of 9 July 2008 setting out the requirements for accreditation and market surveillance relating to the marketing of products (Official Journal of the European Union L 218 of 9 July 2008, p. 30). DAkKS is a signatory to the Multilateral Agreements for Mutual Recognition of the European co-operation for Accreditation (EA), International Accreditation Forum (IAF) and International Laboratory Accreditation Cooperation (ILAC). The signatories to these agreements recognise each other's accreditations.</p> <p>The up-to-date state of membership can be retrieved from the following websites: EA: www.european-accreditation.org ILAC: www.ilac.org IAF: www.iaf.nu</p>

Note: The current certificate annex is published on the website (link see below) of the Accreditation Body DAkKS or may be received by CTC advanced GmbH on request

<https://www.dakks.de/as/ast/d/D-PL-12076-01-05.pdf>

END OF TEST REPORT