



LCIE

Bluetooth Low Energy Template: Release September 27, 2019

TEST REPORT

N°: 163285-741962-A(FILE#1029087)

Version : 01

Subject Radio spectrum matters
tests according to standards:
47 CFR Part 15.247 & RSS-247 Issue 2 & RSS-Gen Issue 5

Issued to **INGENICO**
9 Avenue de la Gare
26958-Valence
FRANCE

Apparatus under test

- Product **Self/045x**
- Trade mark **INGENICO**
- Manufacturer **INGENICO**
- Model under test **Self/0451**
- Serial number **17055221314115110700000**
- FCC ID **XKB-SELFADDON**
- IC **2586D-SELFADDON**

Conclusion See Test Program chapter

Test date October 10, 2019 to October 22, 2019

Test location Fontenay Aux Roses

Test Site 6230B-1

Sample receipt date October 8, 2019

Composition of document 71 pages

Document issued on December 5, 2019

Written by :
Gaetan DESCHAMPS
Gaetan Deschamps
Tests operator

Approved by :
Anthony MERLIN
Technical manager



This document shall not be reproduced, except in full, without the written approval of the LCIE. This document contains results related only to the items tested. It does not imply the conformity of the whole production to the items tested. Unless otherwise specified or rule defined by the test method, the decision of conformity doesn't take into account the uncertainty of measures. This document doesn't anticipate any certification decision.

LCIE

Laboratoire Central des Industries Electriques
Une société de Bureau Veritas

ZI Centr'alp
170 rue de Chatagnon
38430 Moirans FRANCE

Tél : +33 4 76 07 36 36
contact@lcie.fr
www.lcie.fr



PUBLICATION HISTORY

Version	Date	Author	Modification
01	December 5, 2019	Gaetan DESCHAMPS	Creation of the document

Each new edition of this test report replaces and cancels the previous edition. The control of the old editions of report is under responsibility of client.



SUMMARY

1.	TEST PROGRAM	4
2.	EQUIPMENT UNDER TEST: CONFIGURATION (DECLARED BY PROVIDER).....	5
3.	OCCUPIED BANDWIDTH.....	10
4.	20DB EMISSION BANDWIDTH	15
5.	CARRIER FREQUENCY SEPARATION.....	20
6.	NUMBER OF HOPPING FREQUENCY	25
7.	TIME OF OCCUPANCY	30
8.	MAXIMUM CONDUCTED OUTPUT POWER	34
9.	UNWANTED EMISSIONS INTO NON-RESTRICTED FREQUENCY BANDS AT THE BAND EDGE	40
10.	UNWANTED EMISSIONS INTO NON-RESTRICTED FREQUENCY BANDS.....	51
11.	AC POWER LINE CONDUCTED EMISSIONS.....	54
12.	UNWANTED EMISSIONS IN RESTRICTED FREQUENCY BANDS	61
13.	UNCERTAINTIES CHART	71

1. TEST PROGRAM

References

- 47 CFR Part 15.247
- RSS 247 Issue 2
- RSS Gen Issue 5
- KDB 558074 D01 DTS Meas Guidance v05r02
- ANSI C63.10-2013

Radio requirement:

Clause (47CFR Part 15.247 & RSS-247 Issue 2 & RSS-Gen Issue 5) Test Description	Test result - Comments			
Occupied Bandwidth	<input checked="" type="checkbox"/> PASS	<input type="checkbox"/> FAIL	<input type="checkbox"/> NA	<input type="checkbox"/> NP(1)
20dB Bandwidth	<input checked="" type="checkbox"/> PASS	<input type="checkbox"/> FAIL	<input type="checkbox"/> NA	<input type="checkbox"/> NP(1)
Number of Hopping Frequency	<input checked="" type="checkbox"/> PASS	<input type="checkbox"/> FAIL	<input type="checkbox"/> NA	<input type="checkbox"/> NP(1)
Carrier Frequency Separation	<input checked="" type="checkbox"/> PASS	<input type="checkbox"/> FAIL	<input type="checkbox"/> NA	<input type="checkbox"/> NP(1)
Time of Occupancy	<input checked="" type="checkbox"/> PASS	<input type="checkbox"/> FAIL	<input type="checkbox"/> NA	<input type="checkbox"/> NP(1)
Duty Cycle	<input type="checkbox"/> PASS	<input type="checkbox"/> FAIL	<input checked="" type="checkbox"/> NA	<input type="checkbox"/> NP(1)
Maximum Conducted Output Power	<input checked="" type="checkbox"/> PASS	<input type="checkbox"/> FAIL	<input type="checkbox"/> NA	<input type="checkbox"/> NP(1)
Conducted Spurious Emission at the Band Edge	<input checked="" type="checkbox"/> PASS	<input type="checkbox"/> FAIL	<input type="checkbox"/> NA	<input type="checkbox"/> NP(1)
Unwanted Emissions into Non-Restricted Frequency Bands	<input checked="" type="checkbox"/> PASS	<input type="checkbox"/> FAIL	<input type="checkbox"/> NA()	<input type="checkbox"/> NP(1)
AC Power Line Conducted Emission	<input checked="" type="checkbox"/> PASS	<input type="checkbox"/> FAIL	<input type="checkbox"/> NA(2)	<input type="checkbox"/> NP(1)
Unwanted Emissions into Restricted Frequency Bands	<input checked="" type="checkbox"/> PASS	<input type="checkbox"/> FAIL	<input type="checkbox"/> NA	<input type="checkbox"/> NP(1)
Receiver Radiated emissions	<input type="checkbox"/> PASS	<input type="checkbox"/> FAIL	<input checked="" type="checkbox"/> NA	<input type="checkbox"/> NP(1)
This table is a summary of test report, see conclusion of each clause of this test report for detail.				

(1): Limited program

(2): EUT not directly or indirectly connected to the AC Power Public Network

PASS: EUT complies with standard's requirement

FAIL: EUT does not comply with standard's requirement

NA: Not Applicable

NP: Test Not Performed

2. EQUIPMENT UNDER TEST: CONFIGURATION (DECLARED BY PROVIDER)

2.1. HARDWARE IDENTIFICATION (EUT AND AUXILIARIES):

Equipment under test (EUT):
INGENICO Self/0451

Serial Number: 1705522131411511070000



Equipment Under Test

Power supply:

During all the tests, EUT is supplied by V_{nom} : 28VDC
For measurement with different voltage, it will be presented in test method.

Name	Type	Rating	Reference / Sn	Comments
Supply1	<input type="checkbox"/> AC <input checked="" type="checkbox"/> DC <input type="checkbox"/> Battery	10-45VDC	/	For Host equipment
Internal	<input type="checkbox"/> AC <input checked="" type="checkbox"/> DC <input type="checkbox"/> Battery	9-16VDC	/	For ADD ON RADIO equipment (provided by Host equipment)

Voltage table used (for Power Line Conducted Emissions):

Type	Measurement performed:	
<input checked="" type="checkbox"/> AC	<input checked="" type="checkbox"/> 120VAC/60Hz	<input checked="" type="checkbox"/> 240VAC/50Hz
<input type="checkbox"/> DC	<input type="checkbox"/> +12VDC	<input type="checkbox"/> -...VDC
<input type="checkbox"/> Battery	<input type="checkbox"/> +3.6VDC	<input type="checkbox"/> -...VDC
<input type="checkbox"/> USB (Laptop auxiliary)	<input type="checkbox"/> 120VAC/60Hz (Laptop auxiliary)	<input type="checkbox"/> 240VAC/50Hz(Laptop auxiliary)



Inputs/outputs - Cable:

Access	Type	Length used (m)	Declared <3m	Shielded	Under test	Comments
Supply1	2 wires	0.30	<input type="checkbox"/>	<input type="checkbox"/>	<input checked="" type="checkbox"/>	/
COM0	RS232	1.8	<input type="checkbox"/>	<input type="checkbox"/>	<input checked="" type="checkbox"/>	/
COM2	RS232	1.8	<input type="checkbox"/>	<input type="checkbox"/>	<input checked="" type="checkbox"/>	/
Host USB1	USB	1.5	<input type="checkbox"/>	<input checked="" type="checkbox"/>	<input checked="" type="checkbox"/>	/
Host USB2	USB	1.5	<input type="checkbox"/>	<input checked="" type="checkbox"/>	<input checked="" type="checkbox"/>	/
ETH	RJ45 (Ethernet)	1.8	<input type="checkbox"/>	<input type="checkbox"/>	<input checked="" type="checkbox"/>	/
Access6	SAM1	-	<input type="checkbox"/>	<input type="checkbox"/>	<input checked="" type="checkbox"/>	/
Access7	SAM2	-	<input type="checkbox"/>	<input type="checkbox"/>	<input checked="" type="checkbox"/>	/
Access8	µUSB	-	<input type="checkbox"/>	<input type="checkbox"/>	<input checked="" type="checkbox"/>	/
Slave USB	USB	1	<input type="checkbox"/>	<input checked="" type="checkbox"/>	<input checked="" type="checkbox"/>	/

Auxiliary equipment used during test:

Type	Reference	Sn	Comments
AC/DC power source	KEYSIGHT	AC6802A -	A7042305
Bluetooth Tester	CBT	A2440007	R&S

Equipment information:

Bluetooth Classic Type:	<input type="checkbox"/> v1.2	<input type="checkbox"/> v2.0	<input checked="" type="checkbox"/> v2.1+EDR	<input type="checkbox"/> v3.0+HS
	<input type="checkbox"/> v4.0	<input type="checkbox"/> v4.1		<input type="checkbox"/> v4.2
Frequency band:	[2400 – 2483.5] MHz			
Spectrum Modulation:	<input checked="" type="checkbox"/> FHSS			
Number of Channel:	Maximum:	79	Minimum:	20
Spacing channel:	1MHz			
Channel bandwidth:	1MHz			
Antenna Type:	<input type="checkbox"/> Integral	<input checked="" type="checkbox"/> External	<input type="checkbox"/> Dedicated	
Antenna connector:	<input checked="" type="checkbox"/> Yes	<input type="checkbox"/> No	<input type="checkbox"/> Temporary for test	
Transmit chains:	1			
	Single antenna			
	Gain: 0.56dBi			
Beam forming gain:	No			
Receiver chains	1			
Type of equipment:	<input checked="" type="checkbox"/> Stand-alone	<input type="checkbox"/> Plug-in	<input type="checkbox"/> Combined	
Ad-Hoc mode:	<input type="checkbox"/> Yes		<input checked="" type="checkbox"/> No	
Duty cycle:	<input checked="" type="checkbox"/> Continuous duty	<input type="checkbox"/> Intermittent duty	<input type="checkbox"/> 100% duty	
Equipment type:	<input checked="" type="checkbox"/> Production model		<input type="checkbox"/> Pre-production model	
Operating temperature range:	Tmin:	<input checked="" type="checkbox"/> -20°C	<input type="checkbox"/> 0°C	<input type="checkbox"/> °C
	Tnom:	20°C		
	Tmax:	<input type="checkbox"/> 35°C	<input type="checkbox"/> 55°C	<input checked="" type="checkbox"/> 65°C
Type of power source:	<input type="checkbox"/> AC power supply	<input checked="" type="checkbox"/> DC power supply	<input type="checkbox"/> Battery	
Operating voltage range:	Vnom:	<input type="checkbox"/> 230V/50Hz	<input checked="" type="checkbox"/> 28Vdc	



L C I E

WS

CHANNEL PLAN					
Channel	Frequency (MHz)	Channel	Frequency (MHz)	Channel	Frequency (MHz)
Cmin: 0	2402	27	2429	54	2456
1	2403	28	2430	55	2457
2	2404	29	2431	56	2458
3	2405	30	2432	57	2459
4	2406	31	2433	58	2460
5	2407	32	2434	59	2461
6	2408	33	2435	60	2462
7	2409	34	2436	61	2463
8	2410	35	2437	62	2464
9	2411	36	2438	63	2465
10	2412	37	2439	64	2466
11	2413	38	2440	65	2467
12	2414	39	2441	66	2468
13	2415	40	2442	67	2469
14	2416	41	2443	68	2470
15	2417	42	2444	69	2471
16	2418	43	2445	70	2472
17	2419	44	2446	71	2473
18	2420	45	2447	72	2474
19	2421	46	2448	73	2475
20	2422	47	2449	74	2476
21	2423	48	2450	75	2477
22	2424	49	2451	76	2478
23	2425	50	2452	77	2479
24	2426	51	2453	Cmax: 78	2480
25	2427	52	2454		
26	2428	53	2455		

DATA RATE				
Available for EUT	Modulation type	Max. Data Rate (Mbps)	Packet type	Worst Case Modulation
<input checked="" type="checkbox"/>	GFSK	1	1-DM1	<input type="checkbox"/>
	GFSK	1	1-DH1	<input checked="" type="checkbox"/>
	GFSK	1	1-DM3	<input type="checkbox"/>
	GFSK	1	1-DH3	<input checked="" type="checkbox"/>
	GFSK	1	1-DM5	<input type="checkbox"/>
	GFSK	1	1-DH5	<input checked="" type="checkbox"/>
<input type="checkbox"/>	GFSK	1	AUX1	<input type="checkbox"/>
<input checked="" type="checkbox"/>	$\pi/4$ DQPSK	2	2-DH1	<input checked="" type="checkbox"/>
	$\pi/4$ DQPSK	2	2-DH3	<input checked="" type="checkbox"/>
	$\pi/4$ DQPSK	2	2-DH5	<input checked="" type="checkbox"/>
	8DPSK	3	3-DH1	<input checked="" type="checkbox"/>
	8DPSK	3	3-DH3	<input checked="" type="checkbox"/>



L C I E

	8DPSK	3	3-DH5	<input checked="" type="checkbox"/>
--	-------	---	-------	-------------------------------------

2.2. RUNNING MODE

Test mode	Description of test mode
Test mode 1	Permanent emission with modulation on a fixed channel in the data rate that produced the highest power
Test mode 2	Permanent emission with modulation & hopping in the data rate that produced the highest power
Test mode 3	Permanent reception

Test	Running mode
Occupied Bandwidth	<input checked="" type="checkbox"/> Test mode 1 (1) <input type="checkbox"/> Alternative test mode()
20dB Bandwidth	<input checked="" type="checkbox"/> Test mode 1 (1) <input type="checkbox"/> Alternative test mode()
Number of Hopping Frequency	<input checked="" type="checkbox"/> Test mode 2 (1) <input type="checkbox"/> Alternative test mode()
Carrier Frequency Separation	<input checked="" type="checkbox"/> Test mode 1 (1) <input type="checkbox"/> Alternative test mode()
Time of Occupancy	<input checked="" type="checkbox"/> Test mode 2 (1) <input type="checkbox"/> Alternative test mode()
Duty Cycle	<input checked="" type="checkbox"/> Test mode 1 (1) <input type="checkbox"/> Alternative test mode()
Maximum Conducted Output Power	<input checked="" type="checkbox"/> Test mode 1 (1) <input type="checkbox"/> Alternative test mode()
Conducted Spurious Emission at the Band Edge	<input checked="" type="checkbox"/> Test mode 1 (1) <input type="checkbox"/> Alternative test mode()
Unwanted Emissions into Non-Restricted Frequency Bands	<input checked="" type="checkbox"/> Test mode 1 (1) <input type="checkbox"/> Alternative test mode()
AC Power Line Conducted Emission	<input checked="" type="checkbox"/> Test mode 2 (1) <input type="checkbox"/> Alternative test mode()
Unwanted Emissions into Restricted Frequency Bands	<input checked="" type="checkbox"/> Test mode 1 (1) <input type="checkbox"/> Alternative test mode()
Receiver Radiated emissions	<input checked="" type="checkbox"/> Test mode 3 (1) <input type="checkbox"/> Alternative test mode()

The EUT is set in the following modes during tests (with CBT Bluetooth tester):

- Permanent emission with modulation on a fixed channel in the data rate that produced the highest power
- Permanent emission with modulation & hopping in the data rate that produced the highest power

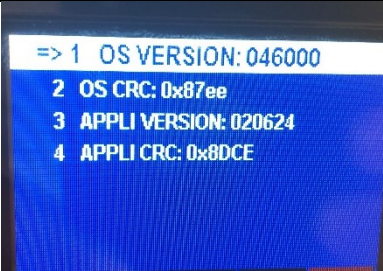
Hardware information
 <pre> => 1 OS VERSION: 046000 2 OS CRC: 0x87ee 3 APPLI VERSION: 020624 4 APPLI CRC: 0x8DCE </pre>

2.3. EQUIPMENT MODIFICATION

None Modification:

3. OCCUPIED BANDWIDTH

3.1. TEST CONDITIONS

Test performed by : Gaetan DESCHAMPS
 Date of test : October 17, 2019
 Ambient temperature : 23 °C
 Relative humidity : 32 %

3.2. TEST SETUP

- The Equipment under Test is installed:

- On a table
- In an anechoic chamber

- Measurement is performed with a spectrum analyzer in:

- Conducted Method
- Radiated Method

Packet type: 1-DH5 / 2-DH5 / 3-DH5 Worst case presented

- Test Procedure:

- RSS-Gen Issue 5 § 6.7
- ANSI C63.10 § 6.9.2

Measurement Procedure:

- a) RBW shall be in the range of 1% to 5% of the anticipated occupied bandwidth
- b) Set the video bandwidth (VBW) $\geq 3 \times$ RBW
- c) SPAN = Capture all products of the modulation process
- d) Detector = Peak.
- e) Trace mode = max hold.
- f) Sweep = auto couple.
- g) Allow the trace to stabilize.
- h) OBW 99% function of spectrum analyzer used

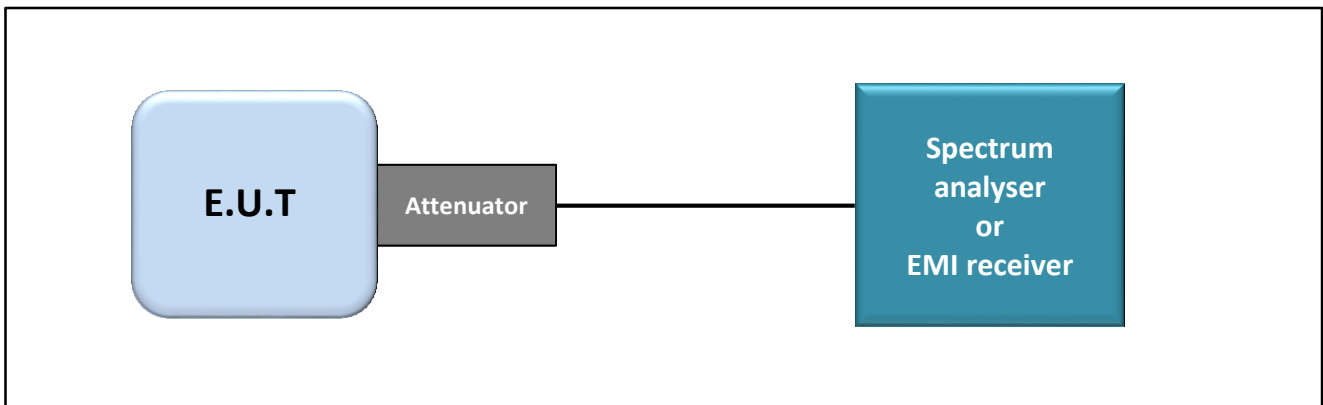

Test set up of Occupied Bandwidth



L C I E

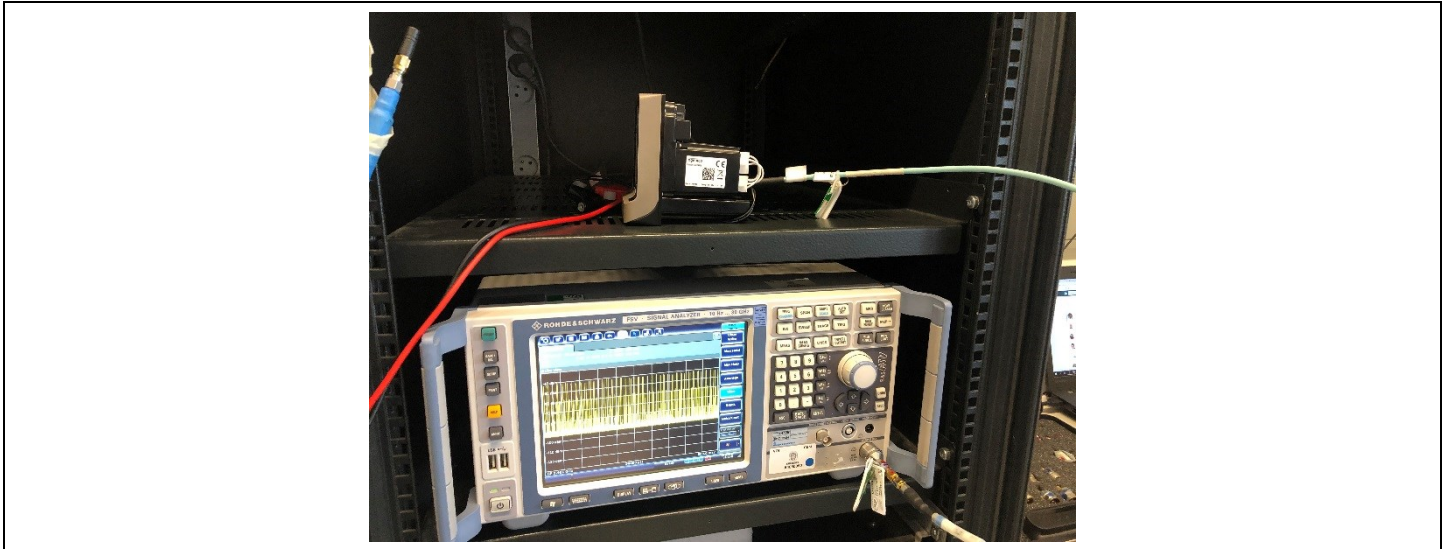

Photograph for Occupied bandwidth

3.3. LIMIT

None

3.4. TEST EQUIPMENT LIST

TEST EQUIPMENT USED					
Description	Manufacturer	Model	Identifier	Last Calibration date	Calibration due date
Cable Measure		36G	A5329604	02/19	02/20
Attenuator 10dB	AEROFLEX		A7122269	12/18	12/19
Bluetooth Tester	ROHDE & SCHWARZ	CBT	A2440007		
SMA 1.5m	SUCOFLEX	18GHz	A5329864	11/18	11/19
Attenuator 10dB	WA	INA 265B	A7122274	09/17	09/19
Thermo-hygrometer (PM1/2/3)	KIMO	HQ 210	B4206022	08/18	08/20
Spectrum analyzer	ROHDE & SCHWARZ	FSV 30	A4060050	12/17	12/19
AC source 1kW	KEYSIGHT	AC6802A	A7042305		
Multimeter	FLUKE	289	A1241119	11/18	11/20
Antenna 2.4GHz	-	SMA	C2040219	-	-

Note: In our quality system, the test equipment calibration due is more & less 2 months



L C I E

3.5. RESULTS

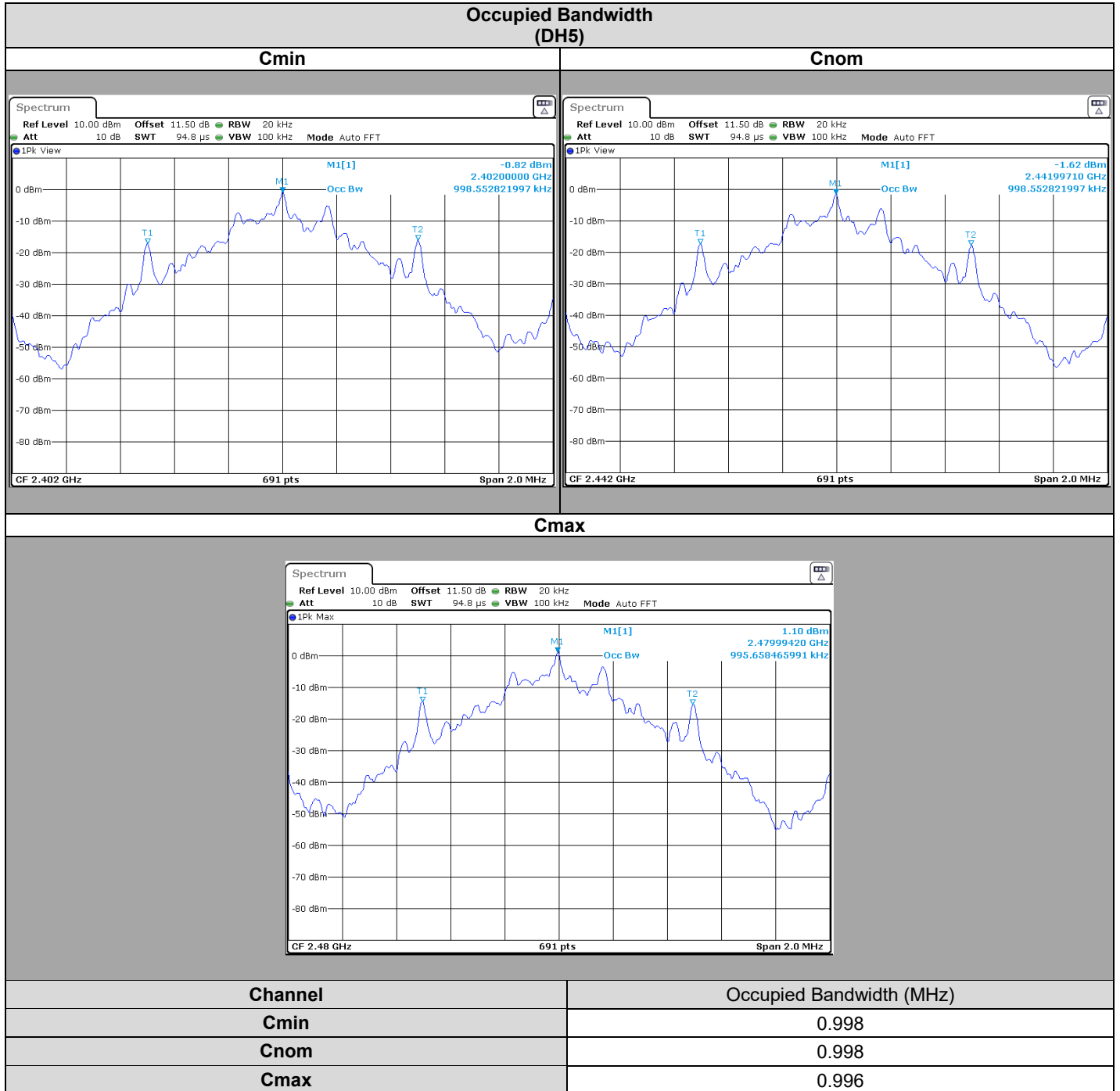



L C I E

Occupied Bandwidth (2-DH5)

Cmin

Cnom

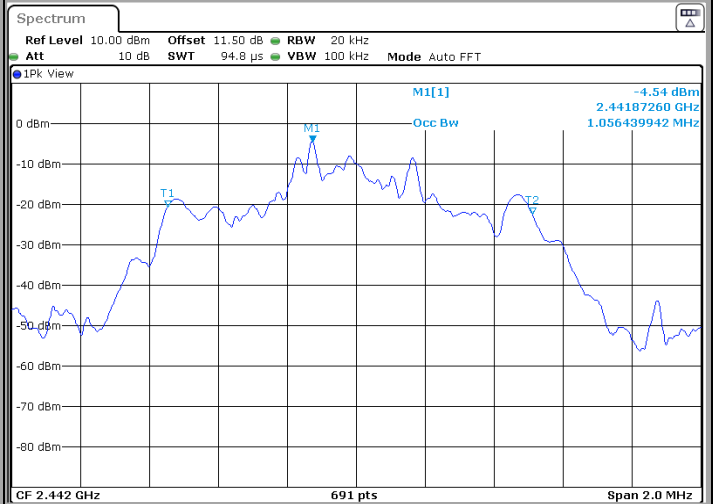
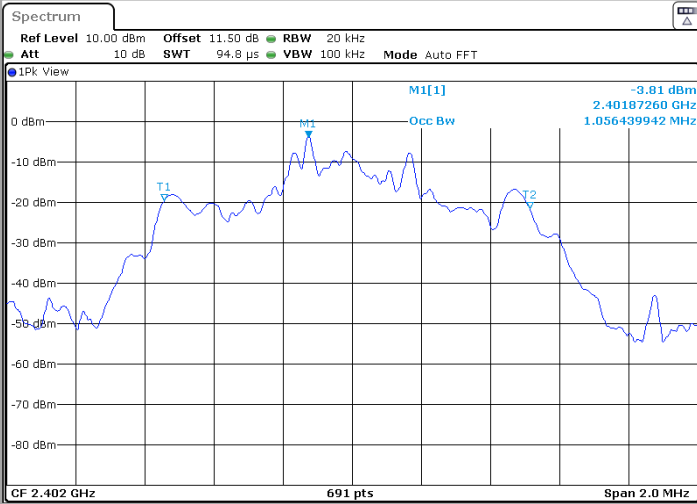

Cmax

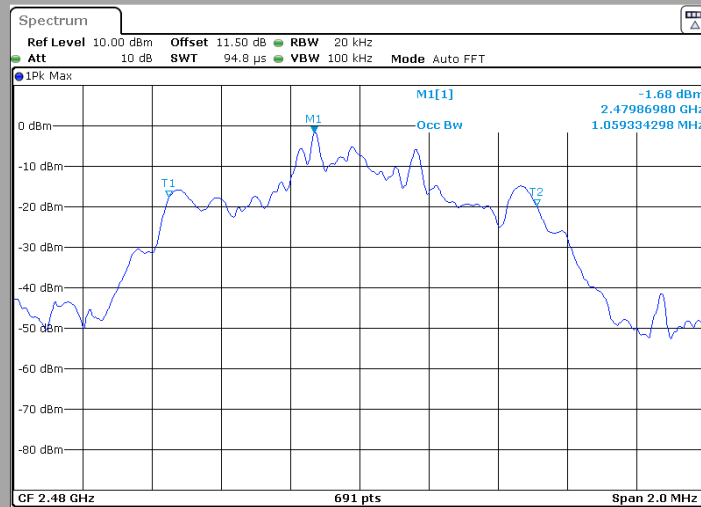

Channel	Occupied Bandwidth (MHz)
Cmin	1.056
Cnom	1.056
Cmax	1.059



L C I E

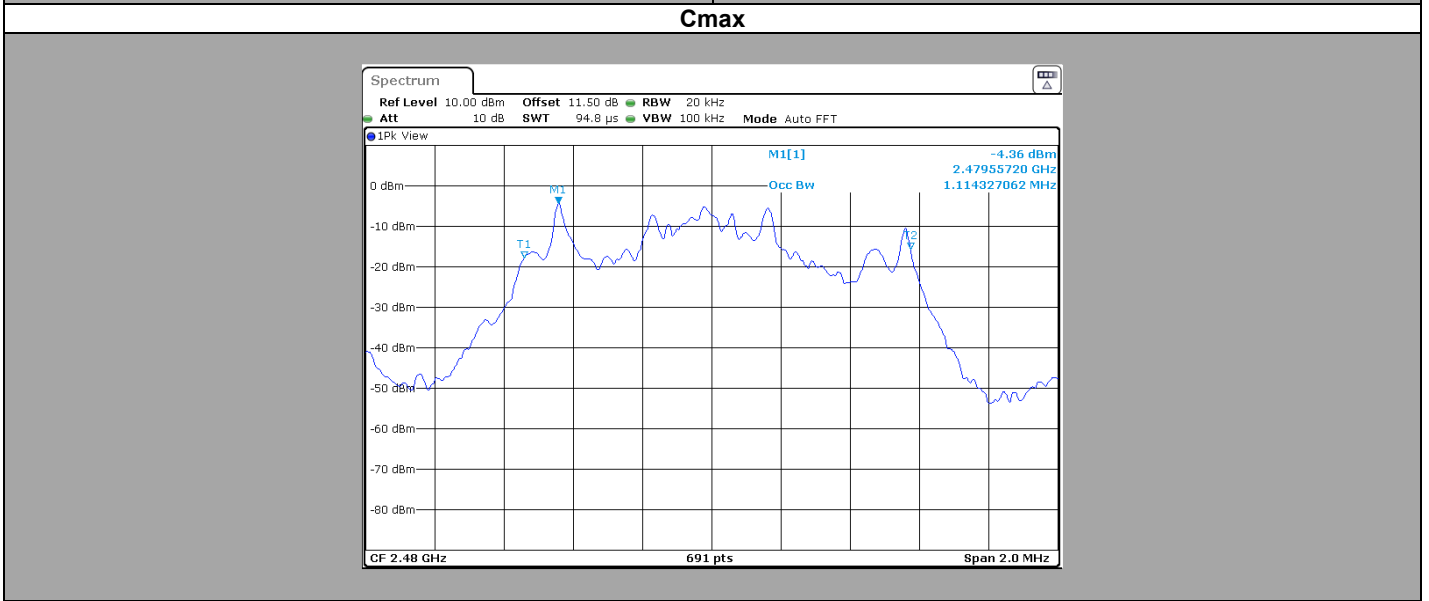
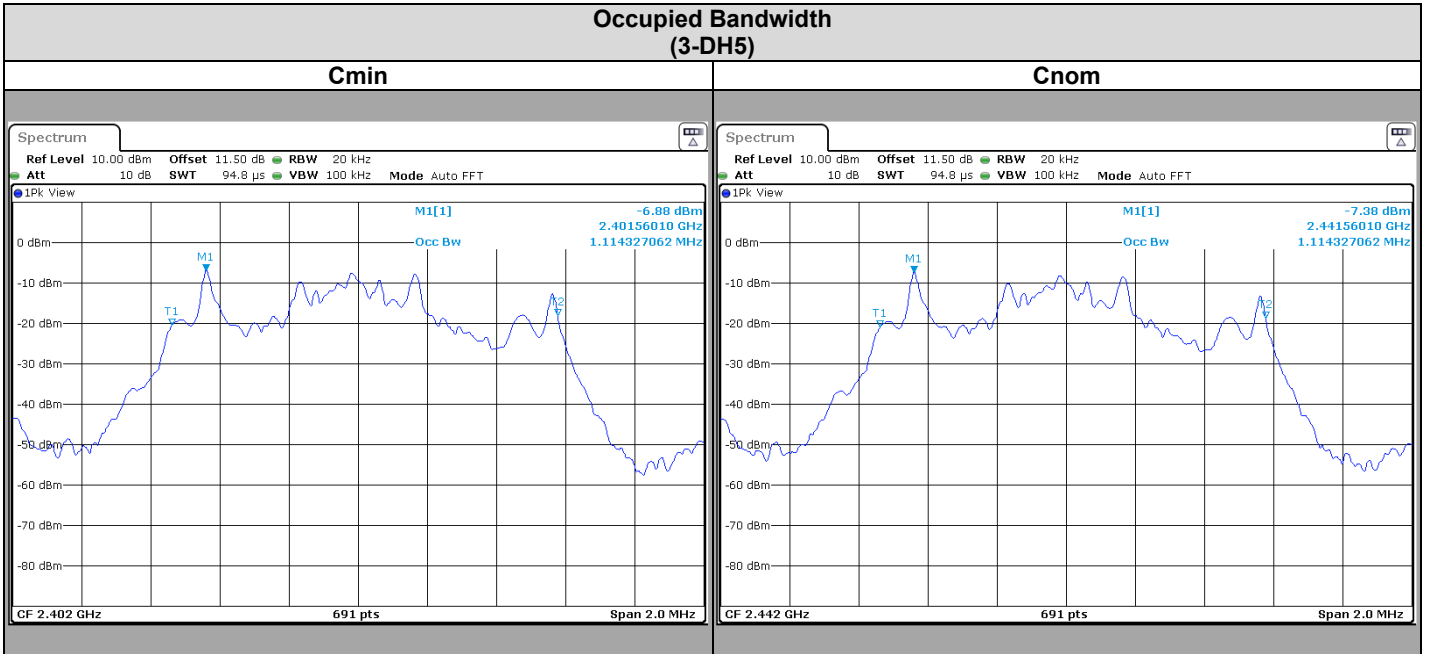

Channel	Occupied Bandwidth (MHz)
Cmin	1.114
Cnom	1.114
Cmax	1.114

3.6. CONCLUSION

Occupied Channel Bandwidth measurement performed on the sample of the product **INGENICO Self/0451**, SN: **1705522131411511070000**, in configuration and description presented in this test report, show levels **compliant** to the **47 CFR PART 15.247 & RSS-GEN ISSUE 5** limits.

4. 20dB EMISSION BANDWIDTH

4.1. TEST CONDITIONS

Test performed by : Gaetan DESCHAMPS
Date of test : October 17, 2019
Ambient temperature : 23 °C
Relative humidity : 32 %

4.2. TEST SETUP

- The Equipment Under Test is installed:

- On a table
- In an anechoic chamber

- Measurement is performed with a spectrum analyzer in:

- Conducted Method
- Radiated Method

Packet type: 1-DH5 / 2-DH5 / 3-DH5 Worst case presented

- Test Procedure:

- ANSI C63.10 § 6.9.2:

The EUT is turn ON and using the MaxHold function, the frequency separation of two frequencies that were attenuated 20dB from the Peak Output Power level. A delta marker is used to measure the frequency difference as the emission bandwidth.

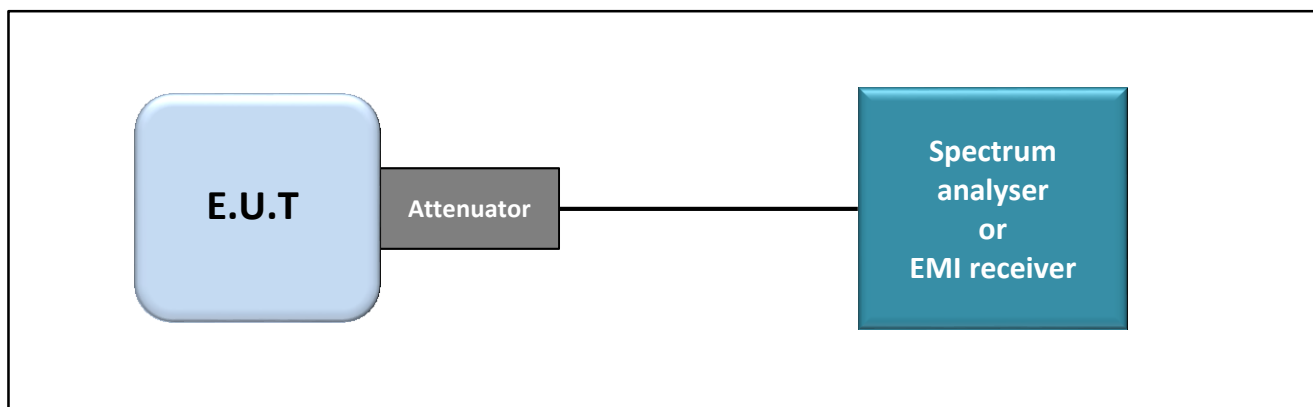

Test set up of 20dB Emission Bandwidth



L C I E

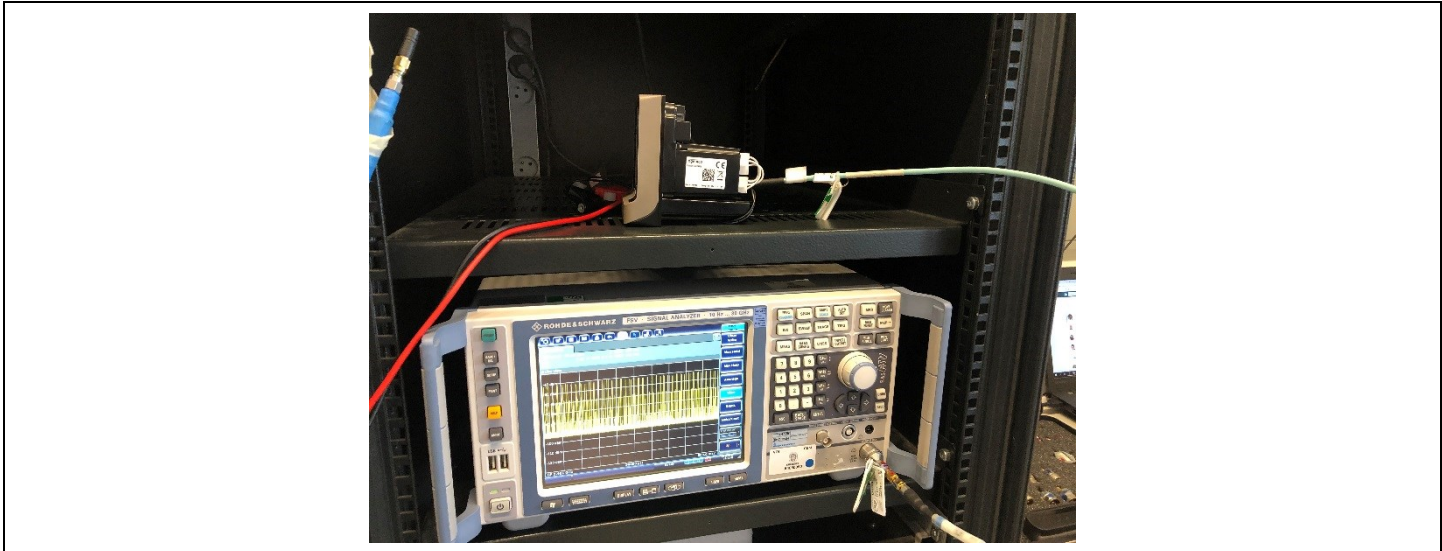

Photograph for 20dB emission bandwidth

4.3. LIMIT

None

4.4. TEST EQUIPMENT LIST

TEST EQUIPMENT USED					
Description	Manufacturer	Model	Identifier	Last Calibration date	Calibration due date
Cable Measure		36G	A5329604	02/19	02/20
Attenuator 10dB	AEROFLEX		A7122269	12/18	12/19
Bluetooth Tester	ROHDE & SCHWARZ	CBT	A2440007		
SMA 1.5m	SUCOFLEX	18GHz	A5329864	11/18	11/19
Attenuator 10dB	WA	INA 265B	A7122274	09/17	09/19
Thermo-hygrometer (PM1/2/3)	KIMO	HQ 210	B4206022	08/18	08/20
Spectrum analyzer	ROHDE & SCHWARZ	FSV 30	A4060050	12/17	12/19
AC source 1kW	KEYSIGHT	AC6802A	A7042305		
Multimeter	FLUKE	289	A1241119	11/18	11/20
Antenna 2.4GHz	-	SMA	C2040219	-	-

Note: In our quality system, the test equipment calibration due is more & less 2 months



L C I E

4.5. RESULTS

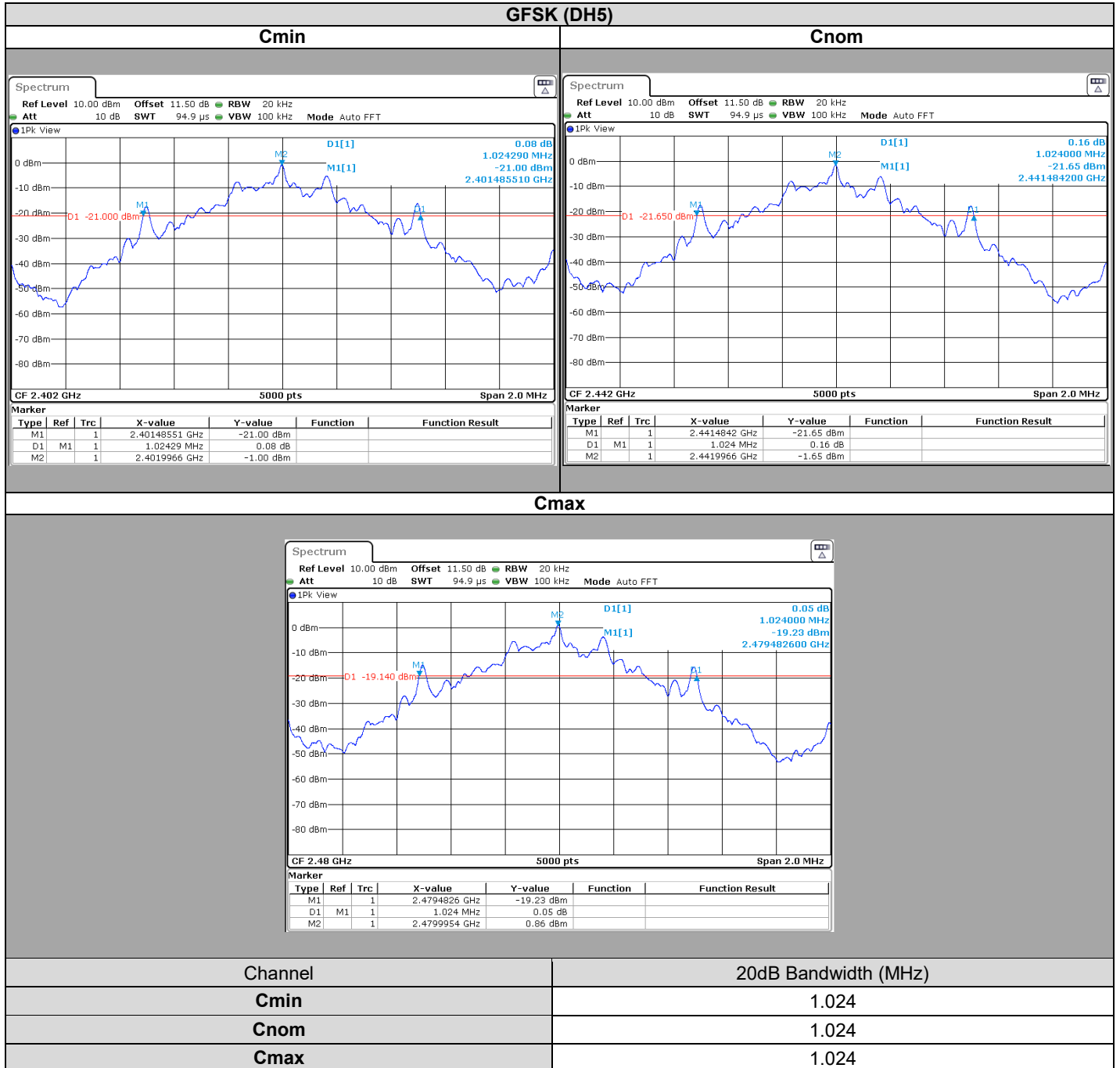



L C I E

$\pi/4$ DQPSK (2-DH5)

Cmin

Cnom

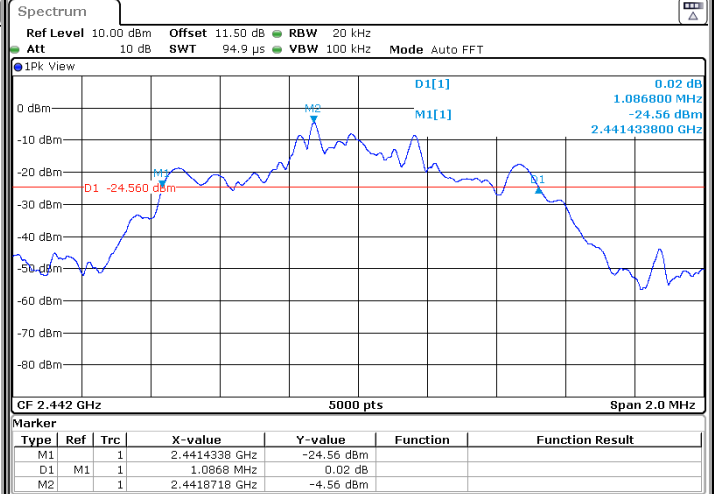
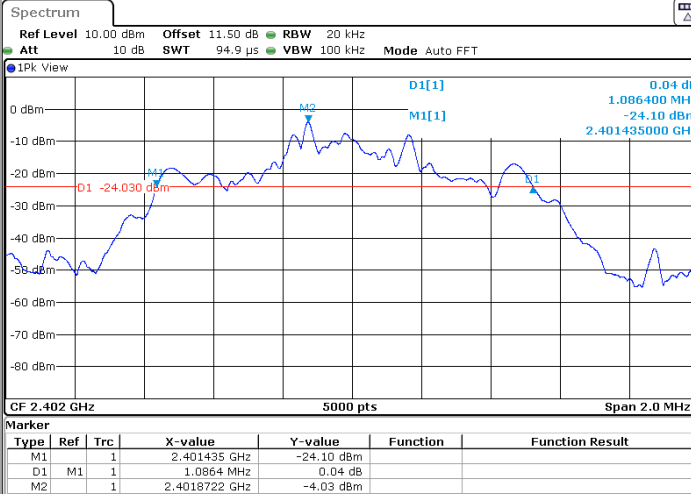

Cmax

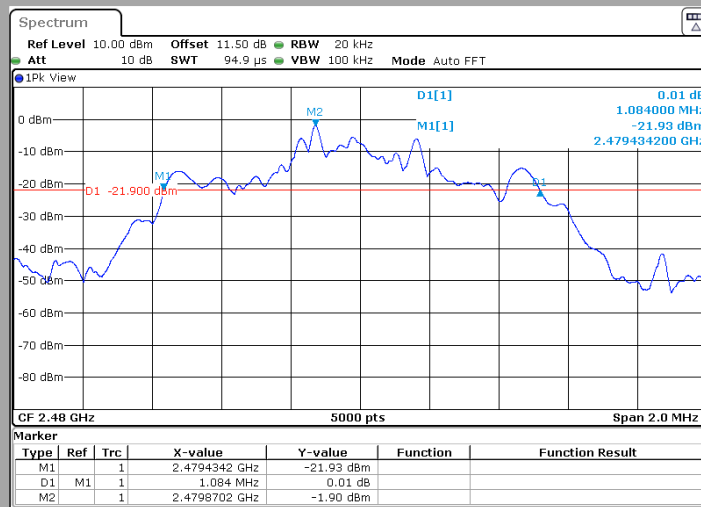

Channel

20dB Bandwidth (MHz)

Cmin

1.086

Cnom

1.086

Cmax

1.084



L C I E

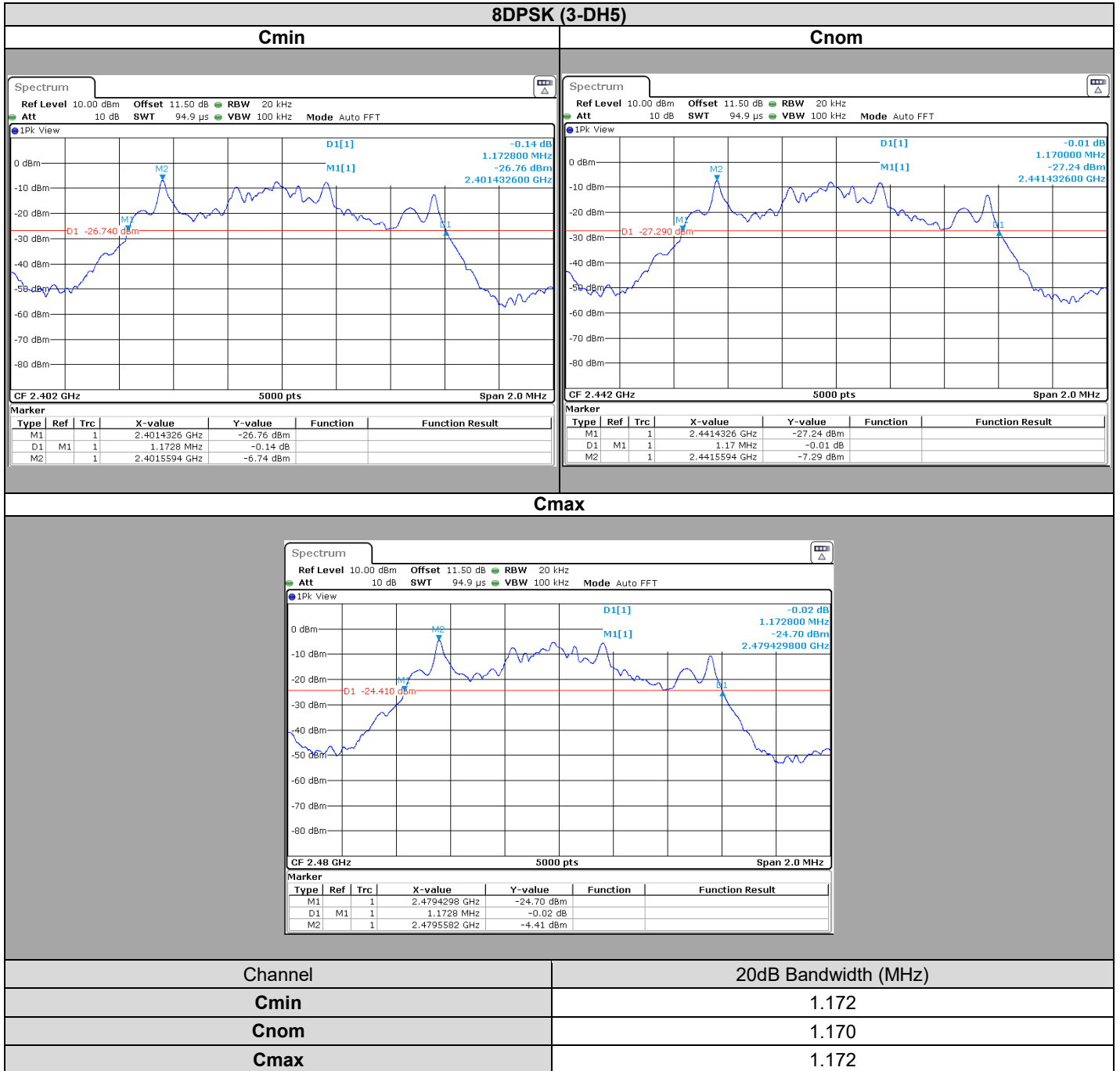

4.6. CONCLUSION

20dB Emission Bandwidth measurement performed on the sample of the product **INGENICO Self/0451**, SN: **1705522131411511070000**, in configuration and description presented in this test report, show levels **compliant** to the **47 CFR PART 15.247 & RSS 247 ISSUE 2** limits.

5. CARRIER FREQUENCY SEPARATION

5.1. TEST CONDITIONS

Test performed by : Gaetan DESCHAMPS
Date of test : October 17, 2019
Ambient temperature : 23 °C
Relative humidity : 32 %

5.2. TEST SETUP

- The Equipment Under Test is installed:

- On a table
- In an anechoic chamber

- Measurement is performed with a spectrum analyzer in:

- Conducted Method
- Radiated Method

Packet type: 1-DH5 / 2-DH5 / 3-DH5 Worst case presented

- Test Procedure:

- ANSI C63.10 § 7.8.2:

The EUT is turn ON and using the MaxHold function, the separation of two adjacent channels is recorded. A delta marker is used to measure the frequency difference.

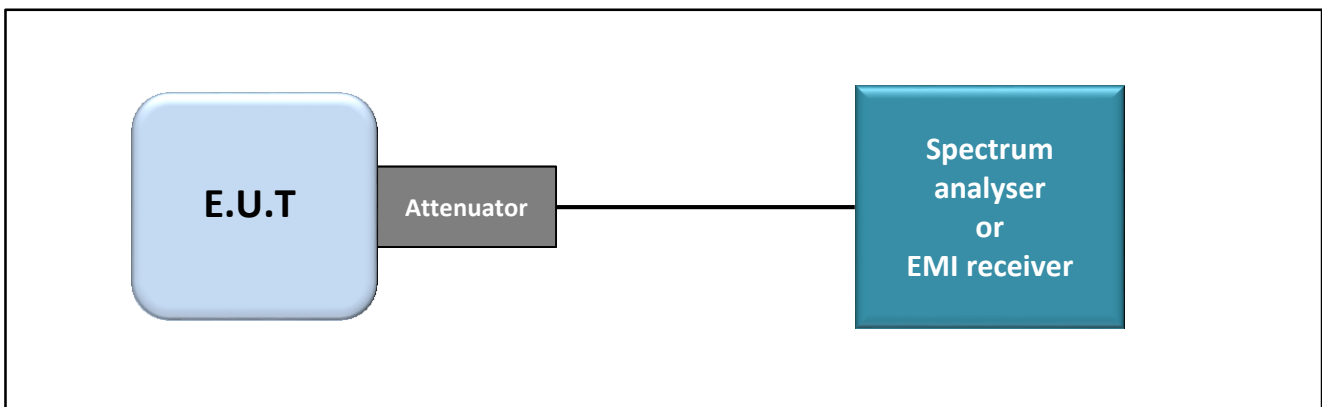

Test set up of Carrier Frequency Separation



L C I E

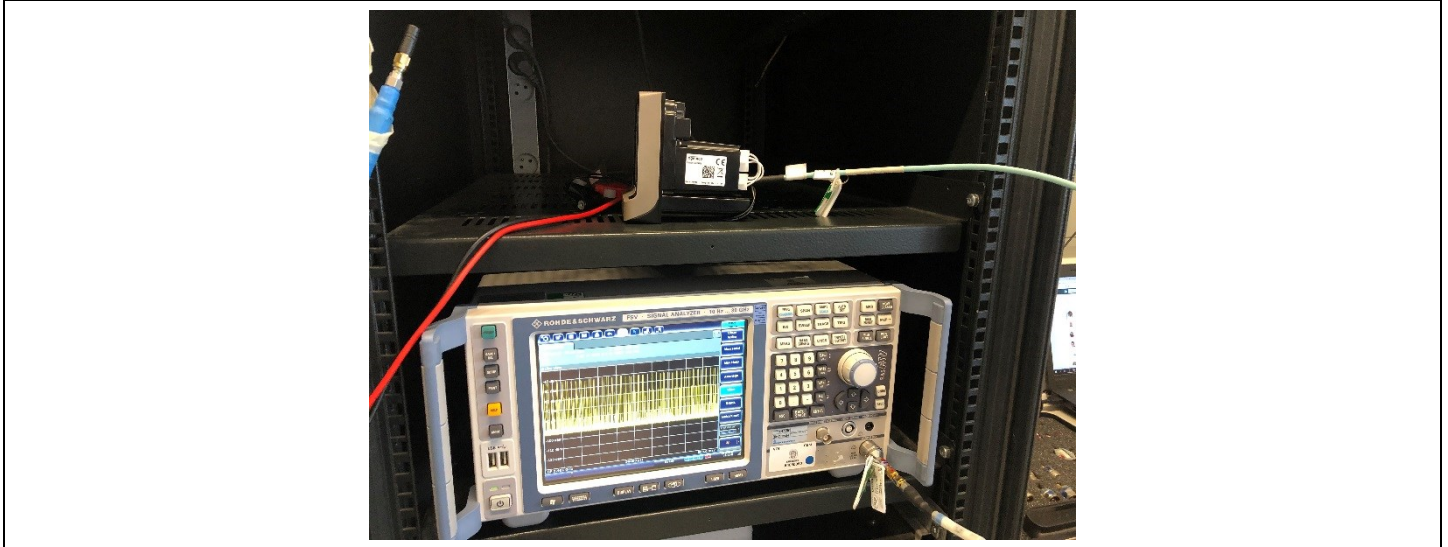

Photograph for Carrier Frequency Separation

5.3. LIMIT

Carrier Frequency Separation shall be at least two-thirds of the 20dB Bandwidth

5.4. TEST EQUIPMENT LIST

TEST EQUIPMENT USED					
Description	Manufacturer	Model	Identifier	Last Calibration date	Calibration due date
Cable Measure		36G	A5329604	02/19	02/20
Attenuator 10dB	AEROFLEX		A7122269	12/18	12/19
Bluetooth Tester	ROHDE & SCHWARZ	CBT	A2440007		
SMA 1.5m	SUCOFLEX	18GHz	A5329864	11/18	11/19
Antenna 2.4GHz	-	SMA	C2040219	-	-
Attenuator 10dB	WA	INA 265B	A7122274	09/17	09/19
Thermo-hygrometer (PM1/2/3)	KIMO	HQ 210	B4206022	08/18	08/20
Spectrum analyzer	ROHDE & SCHWARZ	FSV 30	A4060050	12/17	12/19
AC source 1kW	KEYSIGHT	AC6802A	A7042305		
Multimeter	FLUKE	289	A1241119	11/18	11/20

Note: In our quality system, the test equipment calibration due is more & less 2 months



L C I E

5.5. RESULTS

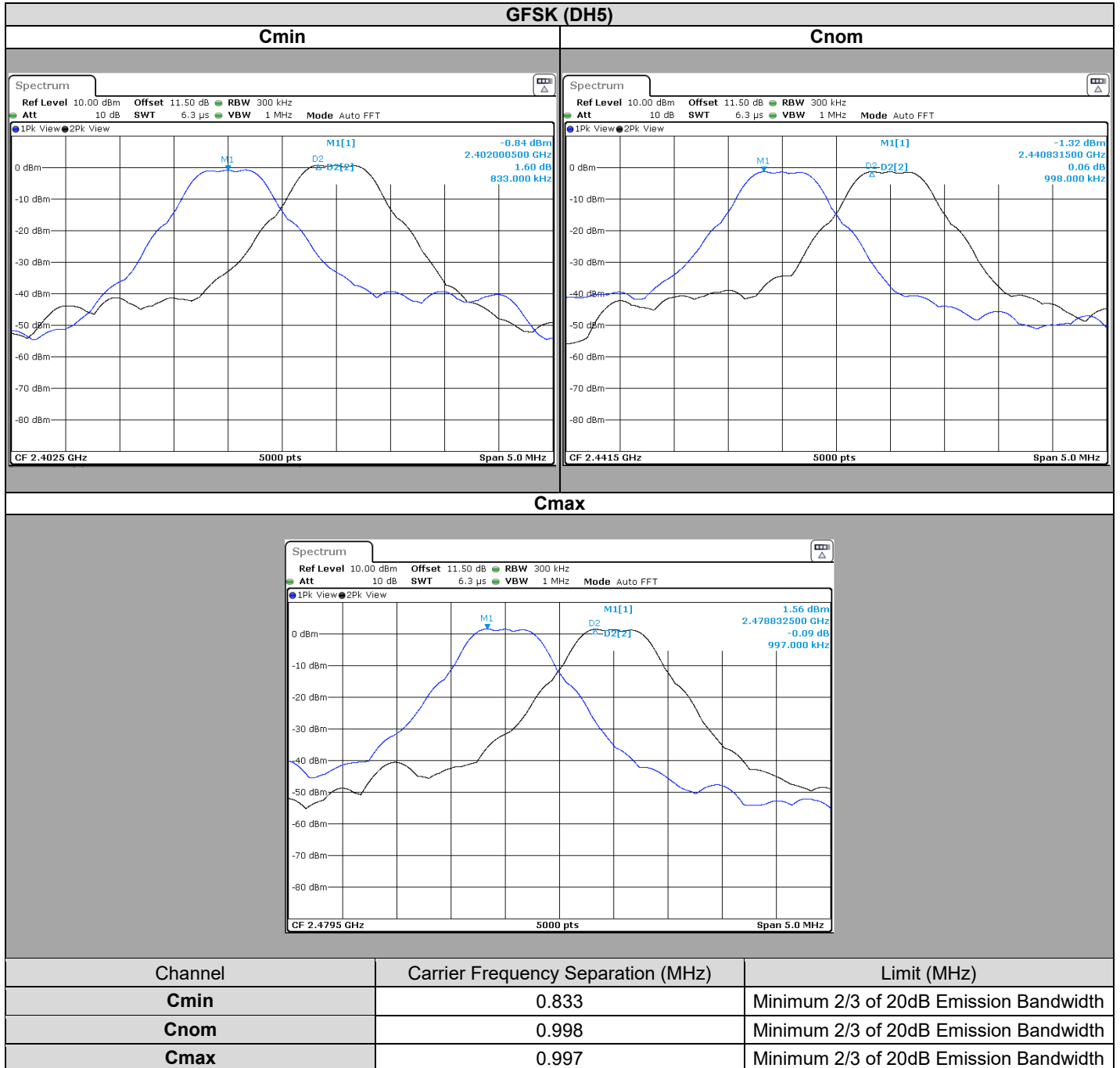



L C I E

$\pi/4$ DQPSK (2-DH5)

Cmin

Cnom

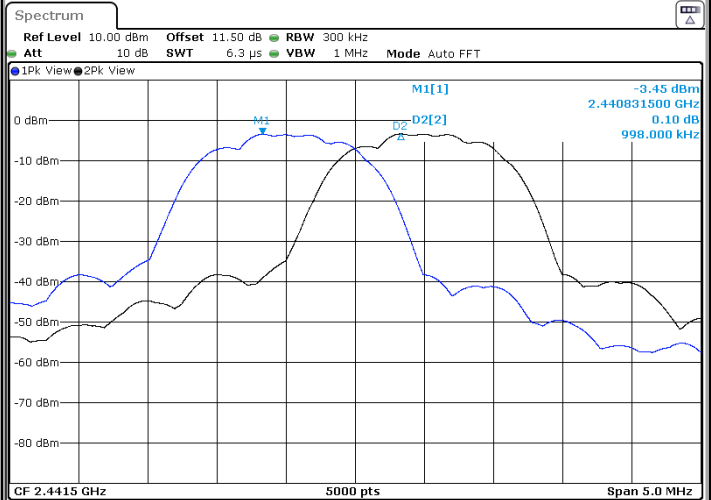
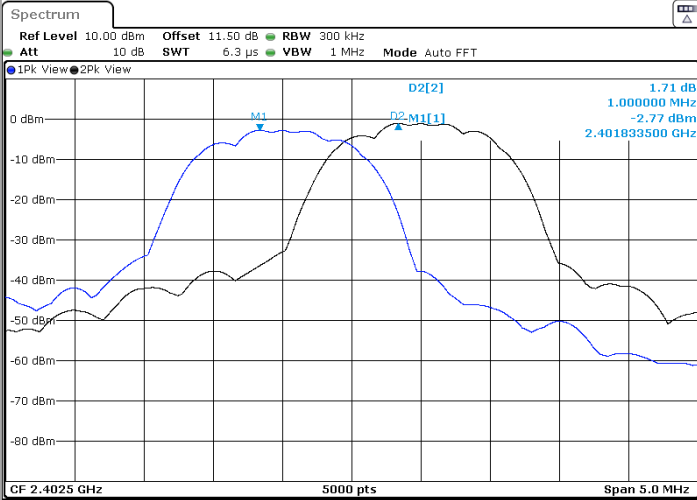

Cmax



Channel	Carrier Frequency Separation (MHz)	Limit (MHz)
Cmin	1.000	Minimum 2/3 of 20dB Emission Bandwidth
Cnom	0.998	Minimum 2/3 of 20dB Emission Bandwidth
Cmax	0.997	Minimum 2/3 of 20dB Emission Bandwidth



L C I E

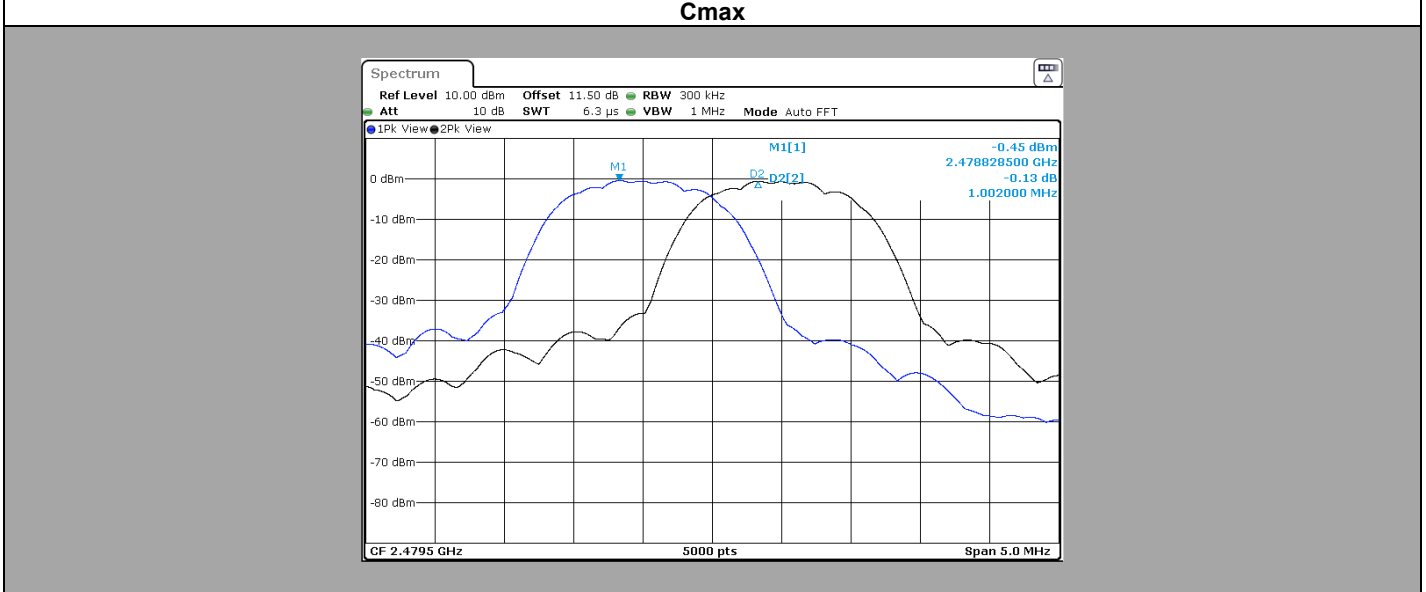
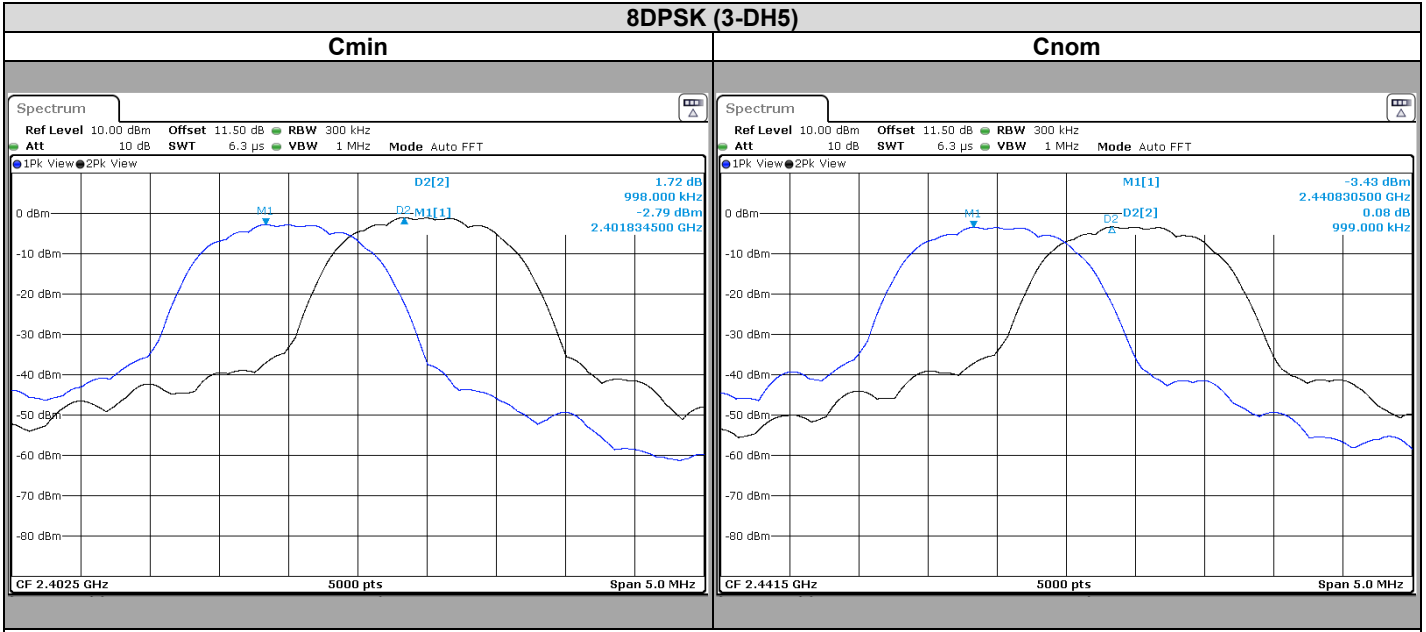

Channel	Carrier Frequency Separation (MHz)	Limit (MHz)
Cmin	0.998	Minimum 2/3 of 20dB Emission Bandwidth
Cnom	0.999	Minimum 2/3 of 20dB Emission Bandwidth
Cmax	1.002	Minimum 2/3 of 20dB Emission Bandwidth

5.6. CONCLUSION

Carrier Frequency Separation measurement performed on the sample of the product **INGENICO Self/0451**, SN: **1705522131411511070000**, in configuration and description presented in this test report, show levels **compliant** to the **47 CFR PART 15.247 & RSS-GEN ISSUE 5** limits.

6. NUMBER OF HOPPING FREQUENCY

6.1. TEST CONDITIONS

Test performed by : Gaetan DESCHAMPS
Date of test : October 17, 2019
Ambient temperature : 23 °C
Relative humidity : 32 %

6.2. TEST SETUP

- The Equipment Under Test is installed:

- On a table
- In an anechoic chamber

- Measurement is performed with a spectrum analyzer in:

- Conducted Method
- Radiated Method

Packet type: 1-DH5 / 2-DH5 / 3-DH5 Worst case presented

- Test Procedure:

- ANSI C63.10 § 7.8.3:

The EUT is turn ON and using the MaxHold function and a delta marker the number of frequencies used for this FHSS system is recorded, see following graphs.

RBW: 100kHz

VBW: 300kHz

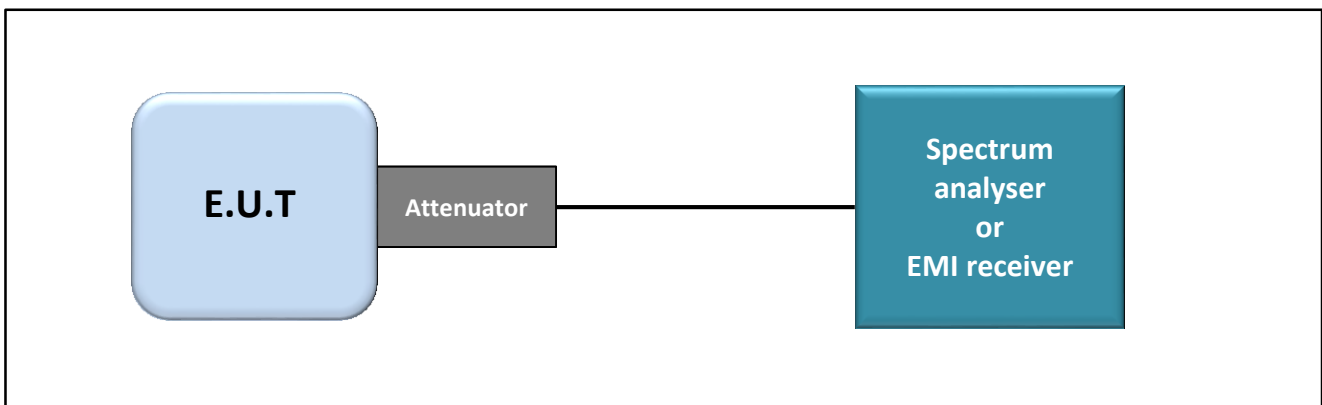

Test set up of Number of Hopping Frequency



L C I E

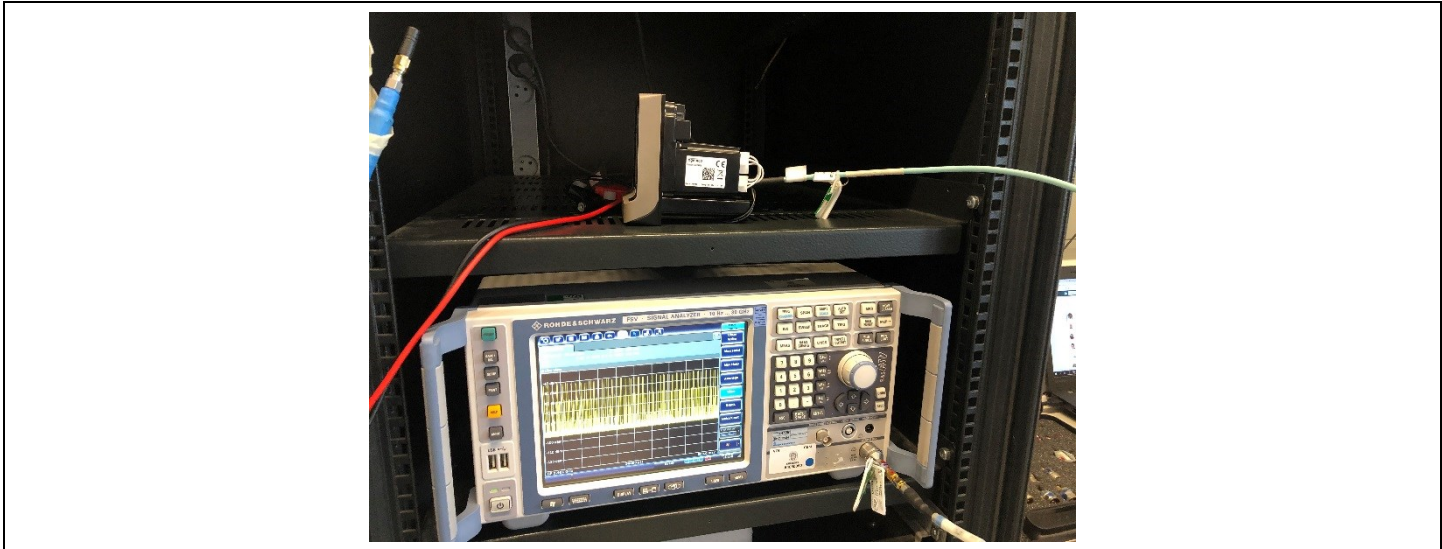

Photograph for Number of Frequency Hopping

6.3. LIMIT

Number of Hopping Frequencies shall be at least 15 channels

6.4. TEST EQUIPMENT LIST

TEST EQUIPMENT USED					
Description	Manufacturer	Model	Identifier	Last Calibration date	Calibration due date
Cable Measure		36G	A5329604	02/19	02/20
Attenuator 10dB	AEROFLEX		A7122269	12/18	12/19
Bluetooth Tester	ROHDE & SCHWARZ	CBT	A2440007		
SMA 1.5m	SUCOFLEX	18GHz	A5329864	11/18	11/19
Attenuator 10dB	WA	INA 265B	A7122274	09/17	09/19
Thermo-hygrometer (PM1/2/3)	KIMO	HQ 210	B4206022	08/18	08/20
Spectrum analyzer	ROHDE & SCHWARZ	FSV 30	A4060050	12/17	12/19
AC source 1kW	KEYSIGHT	AC6802A	A7042305		
Multimeter	FLUKE	289	A1241119	11/18	11/20
Antenna 2.4GHz	-	SMA	C2040219	-	-

Note: In our quality system, the test equipment calibration due is more & less 2 months

6.5. RESULTS

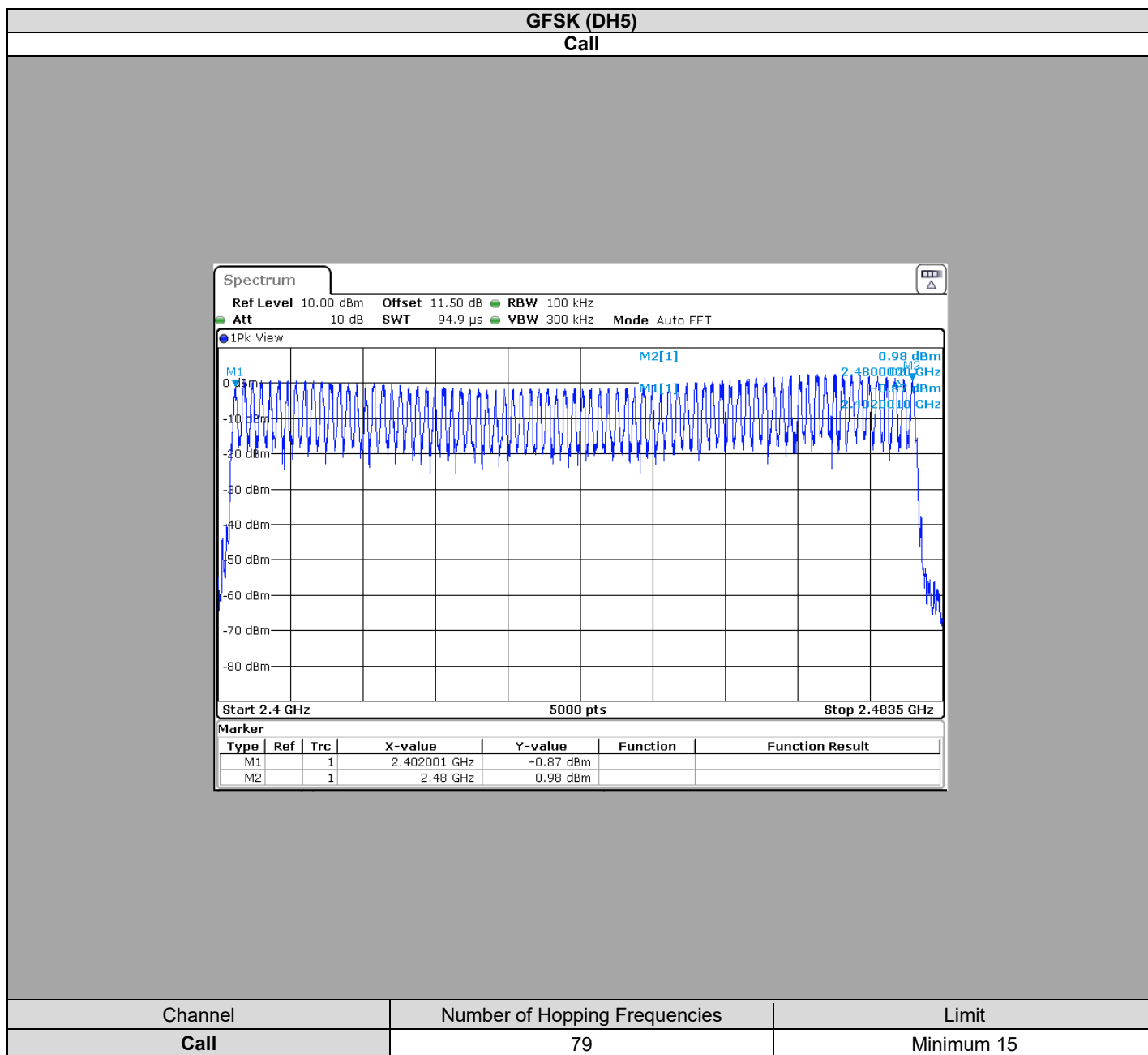



L C I E

$\pi/4$ DQPSK (2-DH5)

Call

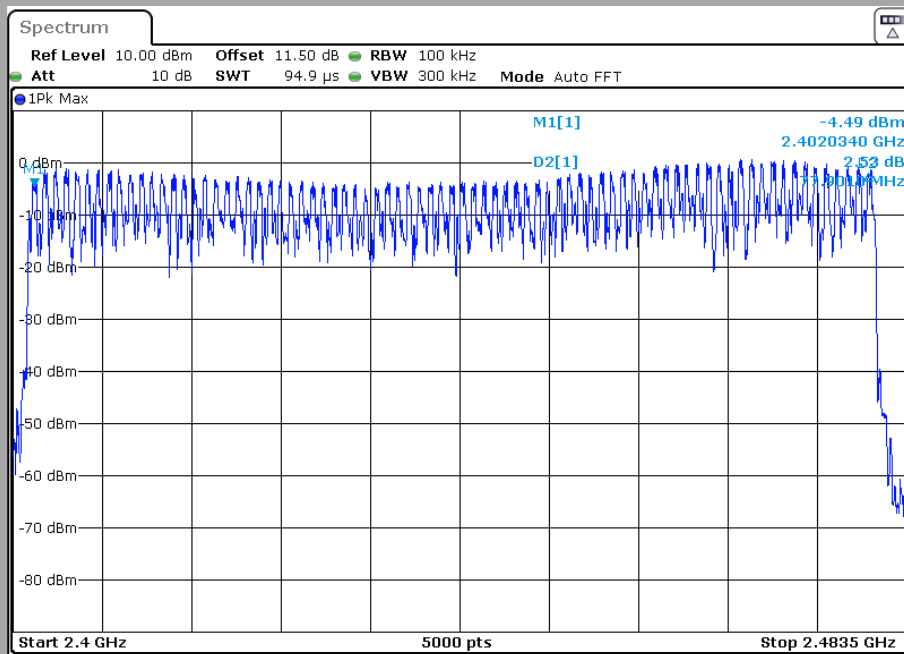

Channel	Number of Hopping Frequencies	Limit
Call	79	Minimum 15



L C I E

8DPSK (3-DH5)

Call

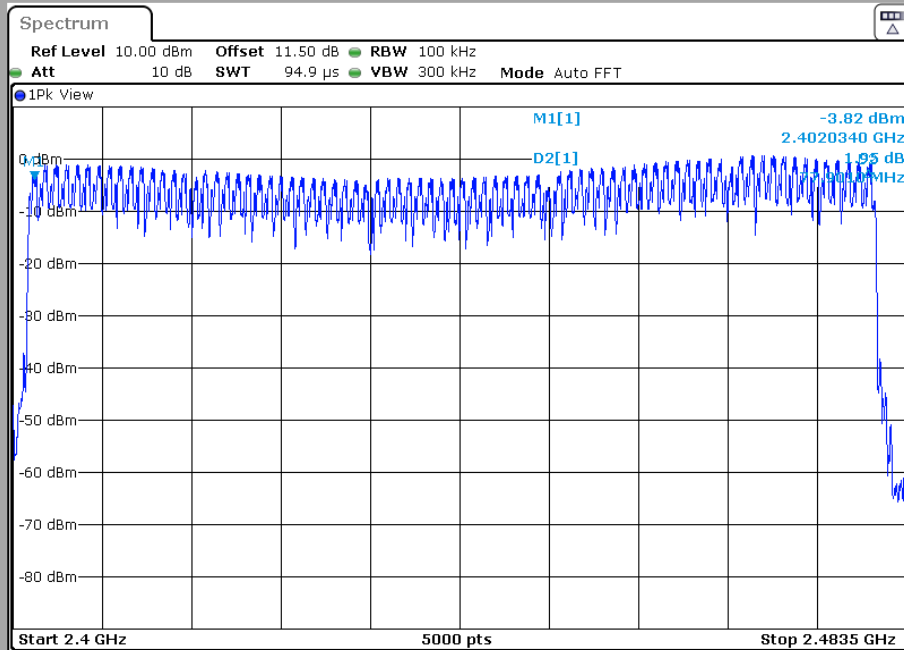

Channel	Number of Hopping Frequencies	Limit
Call	79	Minimum 15

6.6. CONCLUSION

Number of Frequency Hopping measurement performed on the sample of the product **INGENICO Self/0451**, SN: **1705522131411511070000**, in configuration and description presented in this test report, show levels **compliant** to the **47 CFR PART 15.247 & RSS-GEN ISSUE 5** limits.

7. TIME OF OCCUPANCY

7.1. TEST CONDITIONS

Test performed by : Gaetan DESCHAMPS
Date of test : October 17, 2019
Ambient temperature : 23 °C
Relative humidity : 32 %

7.2. TEST SETUP

- The Equipment Under Test is installed:

- On a table
- In an anechoic chamber

- Measurement is performed with a spectrum analyzer in:

- Conducted Method
- Radiated Method

Packet type: 3-DH1 / 3-DH3 / 3-DH5 worst case presented

- Test Procedure:

- ANSI C63.10 § 7.8.4

Dwell Time is measured and calculated using the zero SPAN mode on a channel frequency and a SWEEP with an adapter value to measure the number of transmission within a period and the time of transmission

RBW: 100kHz

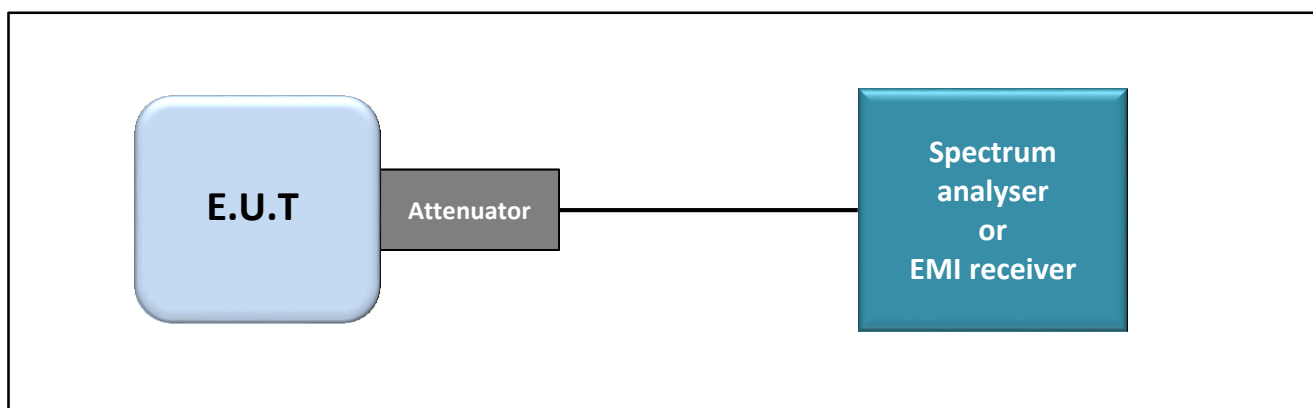

Test set up of Time of Occupancy



L C I E

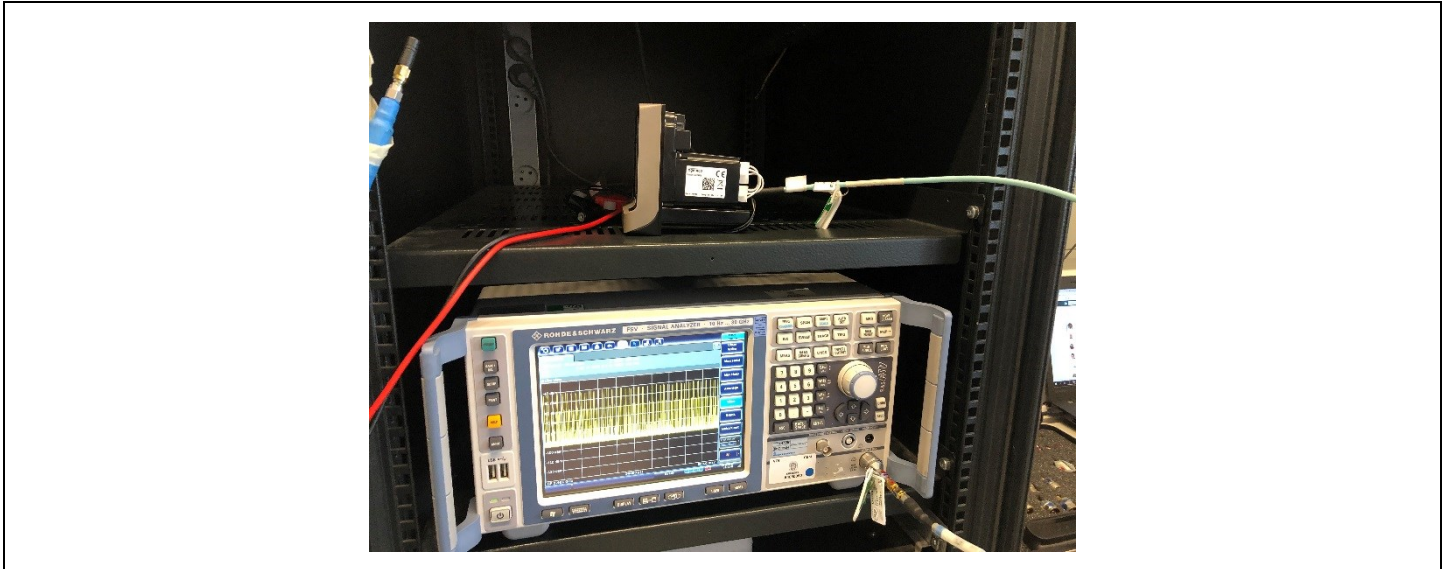

Photograph for Time of Occupancy

7.3. LIMIT

The Time of Occupancy shall not exceed 0.4s within any period of 0.4s multiplied by the number of hopping channels employed

7.4. TEST EQUIPMENT LIST

TEST EQUIPMENT USED					
Description	Manufacturer	Model	Identifier	Last Calibration date	Calibration due date
Cable Measure		36G	A5329604	02/19	02/20
Attenuator 10dB	AEROFLEX		A7122269	12/18	12/19
Bluetooth Tester	ROHDE & SCHWARZ	CBT	A2440007		
SMA 1.5m	SUCOFLEX	18GHz	A5329864	11/18	11/19
Attenuator 10dB	WA	INA 265B	A7122274	09/17	09/19
Thermo-hygrometer (PM1/2/3)	KIMO	HQ 210	B4206022	08/18	08/20
Spectrum analyzer	ROHDE & SCHWARZ	FSV 30	A4060050	12/17	12/19
AC source 1kW	KEYSIGHT	AC6802A	A7042305		
Multimeter	FLUKE	289	A1241119	11/18	11/20
Antenna 2.4GHz	-	SMA	C2040219	-	-

Note: In our quality system, the test equipment calibration due is more & less 2 months

7.5. RESULTS

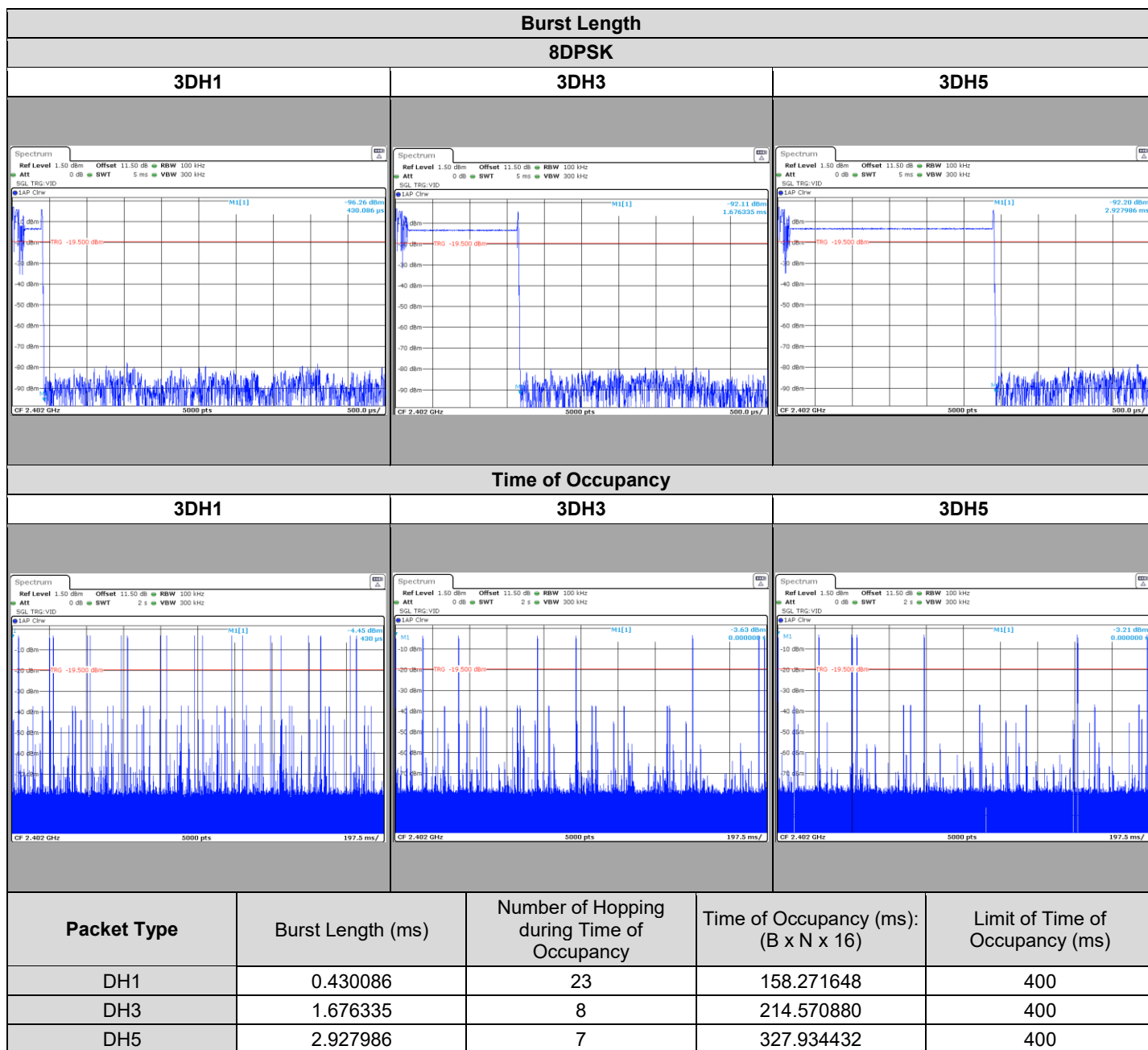

Note: Period of 31.6 seconds (79 channels x 0.4)

7.6. CONCLUSION

Time of Occupancy measurement performed on the sample of the product **INGENICO Self/0451**, SN: **1705522131411511070000**, in configuration and description presented in this test report, show levels **compliant** to the **47 CFR PART 15.247 & RSS-GEN ISSUE 5** limits.



L C I E

8. MAXIMUM CONDUCTED OUTPUT POWER

8.1. TEST CONDITIONS

Test performed by : Gaetan DESCHAMPS
Date of test : October 17, 2019
Ambient temperature : 23 °C
Relative humidity : 32 %

8.2. TEST SETUP

- The Equipment under Test is installed:

- On a table
- In an anechoic chamber

- Measurement is performed with a spectrum analyzer in:

- Conducted Method
- Radiated Method

Packet type: 1-DH5 / 2-DH5 / 3-DH5 Worst case presented

- Test Procedure:

- ANSI C63.10 § 7.8.5

Measurement Procedure:

- a) 1) Span: Approximately five times the 20 dB bandwidth, centered on a hopping channel.
- b) 2) RBW > 20 dB bandwidth of the emission being measured.
- c) 3) VBW \geq RBW.
- d) 4) Sweep: Auto.
- e) 5) Detector function: Peak.
- f) 6) Trace: Max hold.

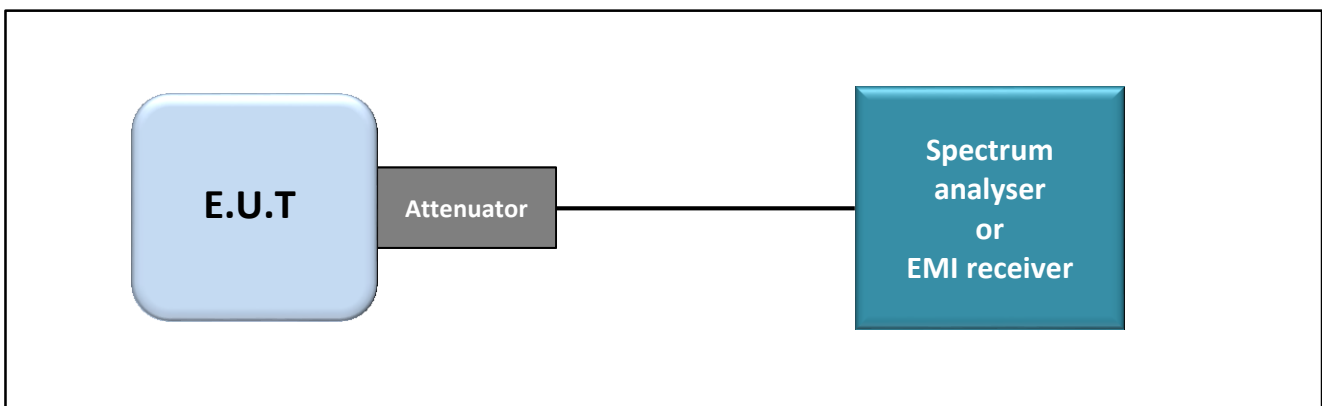

Test set up of Maximum Conducted Output Power



L C I E

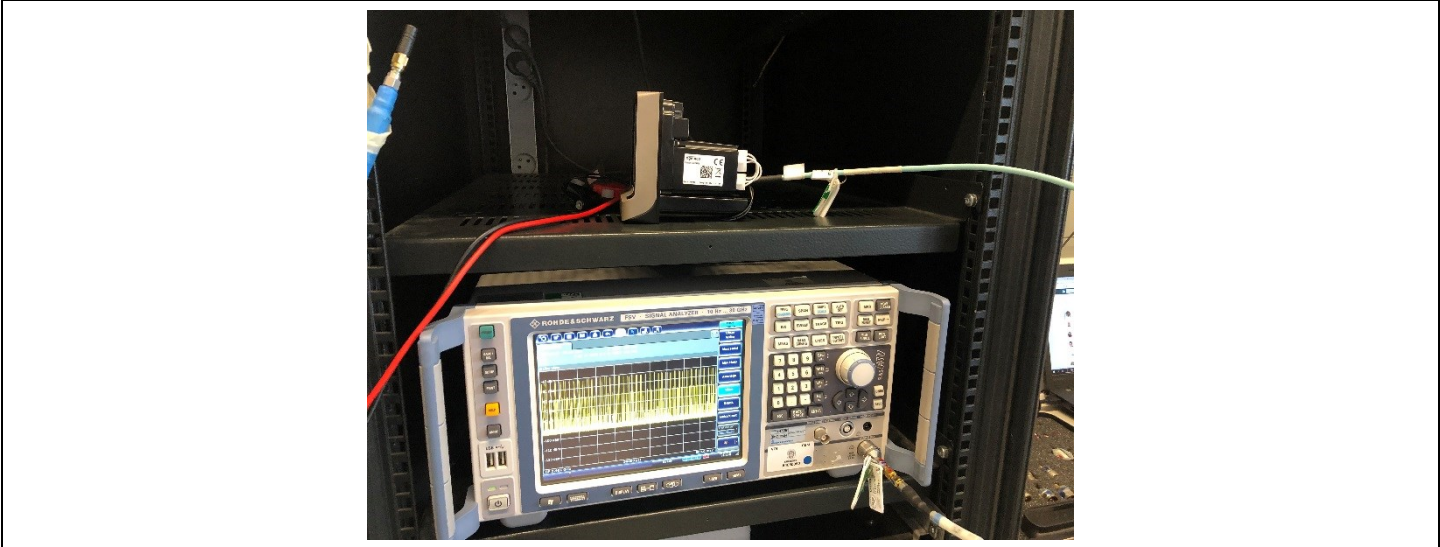

Photograph for Maximum Conducted Output Power

8.3. LIMIT

Maximum Conducted Output power:
Shall not exceed 21dBm
Limits are reduced by G-6dBi if Antenna Gain above 6dBi

8.4. TEST EQUIPMENT LIST

TEST EQUIPMENT USED					
Description	Manufacturer	Model	Identifier	Last Calibration date	Calibration due date
Cable Measure		36G	A5329604	02/19	02/20
Attenuator 10dB	AEROFLEX		A7122269	12/18	12/19
Bluetooth Tester	ROHDE & SCHWARZ	CBT	A2440007		
SMA 1.5m	SUCOFLEX	18GHz	A5329864	11/18	11/19
Attenuator 10dB	WA	INA 265B	A7122274	09/17	09/19
Thermo-hygrometer (PM1/2/3)	KIMO	HQ 210	B4206022	08/18	08/20
Spectrum analyzer	ROHDE & SCHWARZ	FSV 30	A4060050	12/17	12/19
AC source 1kW	KEYSIGHT	AC6802A	A7042305		
Multimeter	FLUKE	289	A1241119	11/18	11/20
Antenna 2.4GHz	-	SMA	C2040219	-	-

Note: In our quality system, the test equipment calibration due is more & less 2 months



L C I E

8.5. RESULTS

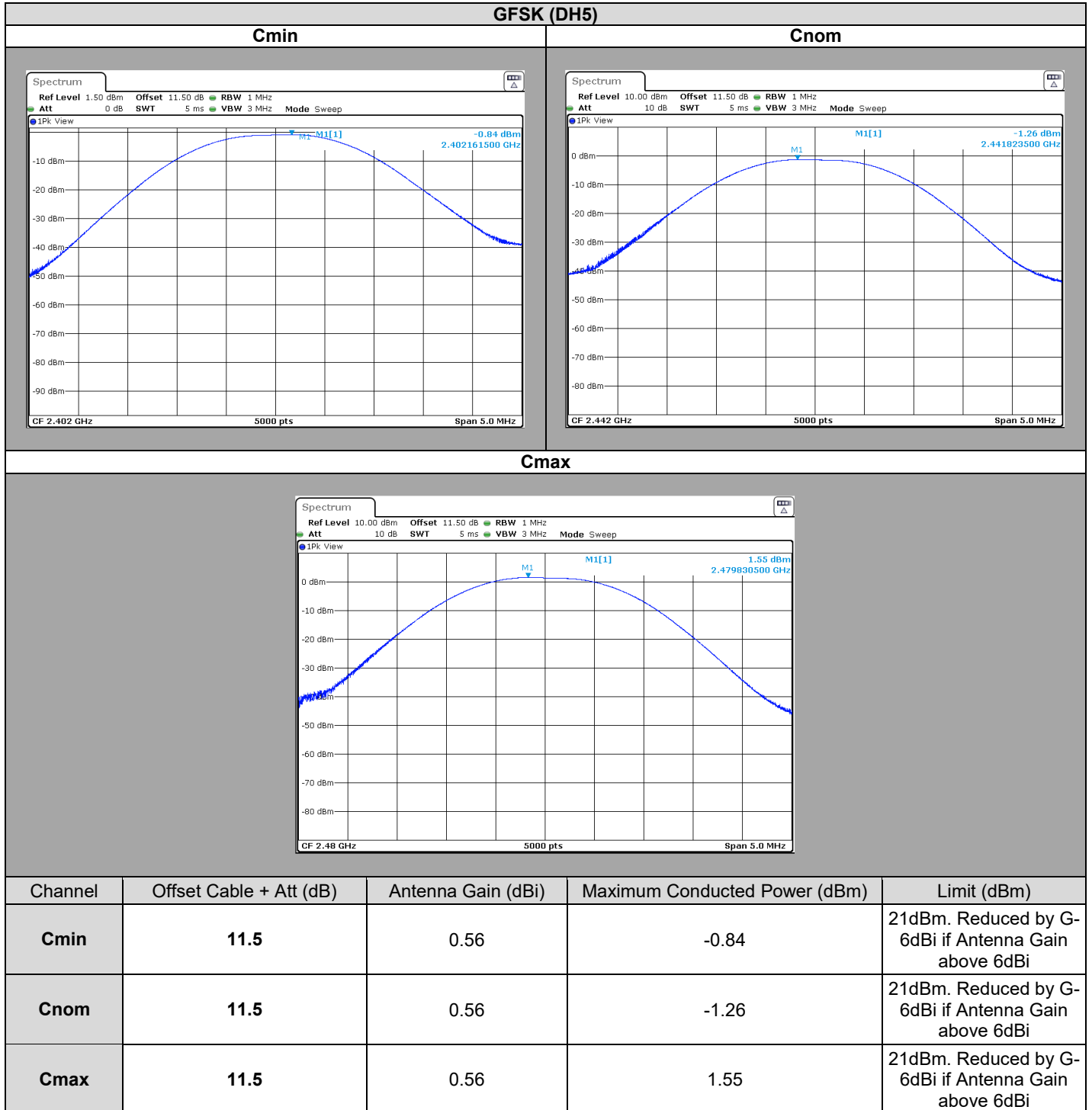



L C I E

$\pi/4$ DQPSK (2-DH5)

Cmin

Cnom

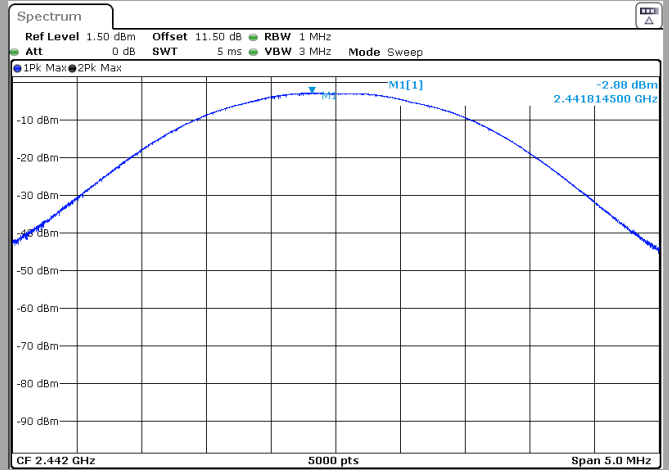
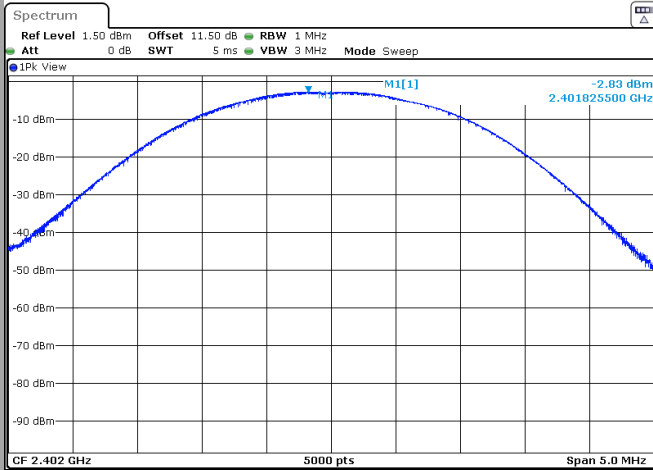

Cmax

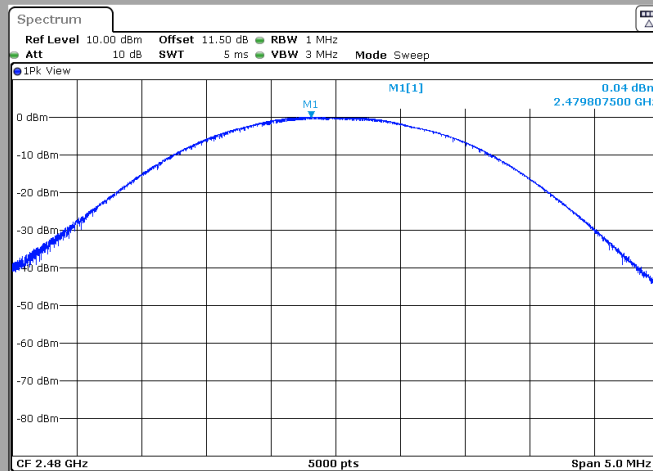

Channel	Offset Cable + Att (dB)	Antenna Gain (dBi)	Maximum Conducted Power (dBm)	Limit (dBm)
Cmin	11.5	0.56	-2.83	21dBm. Reduced by G-6dBi if Antenna Gain above 6dBi
Cnom	11.5	0.56	-2.88	21dBm. Reduced by G-6dBi if Antenna Gain above 6dBi
Cmax	11.5	0.56	0.04	21dBm. Reduced by G-6dBi if Antenna Gain above 6dBi



L C I E

$\pi/4$ DQPSK (3-DH5)

Cmin

Cnom

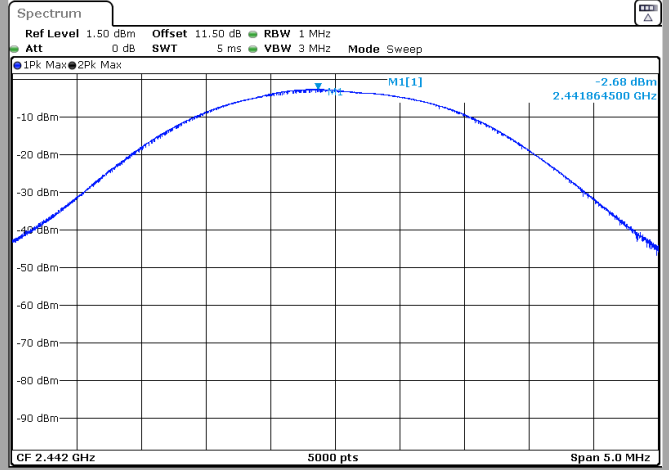
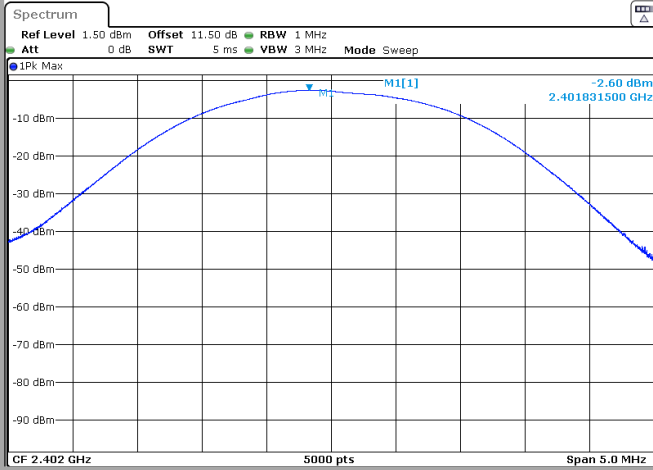

Cmax

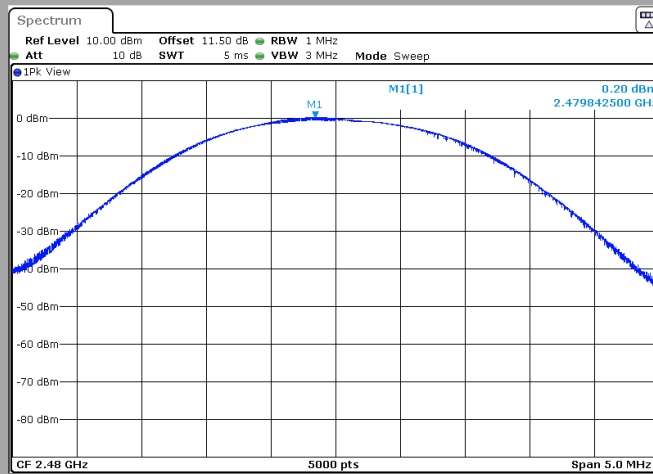

Channel	Offset Cable + Att (dB)	Antenna Gain (dBi)	Maximum Conducted Power (dBm)	Limit (dBm)
Cmin	11.5	0.56	-2.60	21dBm. Reduced by G-6dBi if Antenna Gain above 6dBi
Cnom	11.5	0.56	-2.68	21dBm. Reduced by G-6dBi if Antenna Gain above 6dBi
Cmax	11.5	0.56	0.20	21dBm. Reduced by G-6dBi if Antenna Gain above 6dBi



8.6. CONCLUSION

Maximum Conducted Output Power measurement performed on the sample of the product **INGENICO Self/0451**, SN: **17055221314115110700000**, in configuration and description presented in this test report, show levels **compliant** to the **47 CFR PART 15.247 & RSS 247 ISSUE 2** limits.

9. UNWANTED EMISSIONS INTO NON-RESTRICTED FREQUENCY BANDS AT THE BAND EDGE

9.1. TEST CONDITIONS

Test performed by : Gaetan DESCHAMPS
Date of test : October 21, 2019
Ambient temperature : 23 °C
Relative humidity : 32 %

9.2. TEST SETUP

- The Equipment Under Test is installed:

- On a table
- In an anechoic chamber

- Measurement is performed with a spectrum analyzer in:

- Conducted Method
- Radiated Method

- Test Procedure:

- ANSI C63.10 § 7.8.6

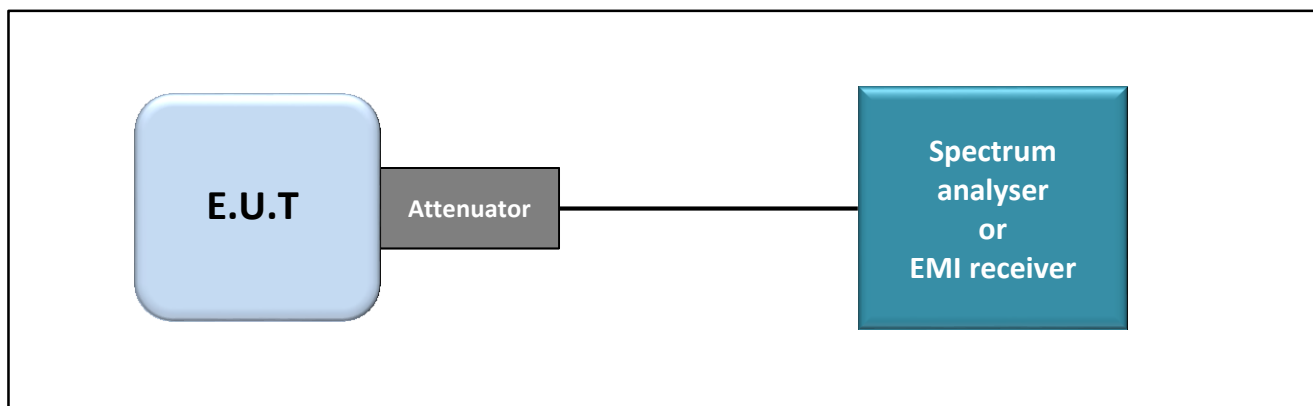

Test set up of Unwanted Emissions into Non-Restricted Frequency Bands at the Band Edge



L C I E

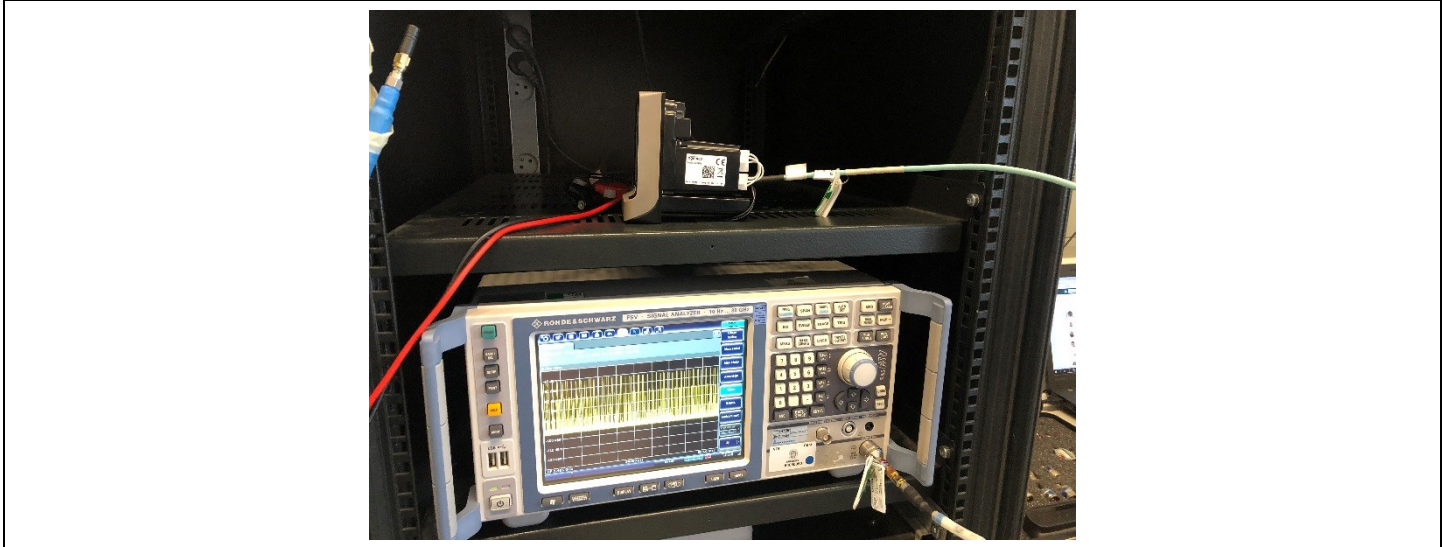

Photograph for Unwanted Emission into non-restricted frequency bands at the band edge

9.3. LIMIT

All Spurious Emissions must be at least 20dB below the Fundamental Radiator Level at the Band Edge Edge “2400MHz & 2483,5MHz”

9.4. TEST EQUIPMENT LIST

TEST EQUIPMENT USED					
Description	Manufacturer	Model	Identifier	Last Calibration date	Calibration due date
Cable Measure		36G	A5329604	02/19	02/20
Attenuator 10dB	AEROFLEX		A7122269	12/18	12/19
Bluetooth Tester	ROHDE & SCHWARZ	CBT	A2440007		
SMA 1.5m	SUCOFLEX	18GHz	A5329864	11/18	11/19
Attenuator 10dB	WA	INA 265B	A7122274	09/17	09/19
Thermo-hygrometer (PM1/2/3)	KIMO	HQ 210	B4206022	08/18	08/20
Spectrum analyzer	ROHDE & SCHWARZ	FSV 30	A4060050	12/17	12/19
AC source 1kW	KEYSIGHT	AC6802A	A7042305		
Multimeter	FLUKE	289	A1241119	11/18	11/20
Antenna 2.4GHz	-	SMA	C2040219	-	-

Note: In our quality system, the test equipment calibration due is more & less 2 months



L C I E

9.5. RESULTS

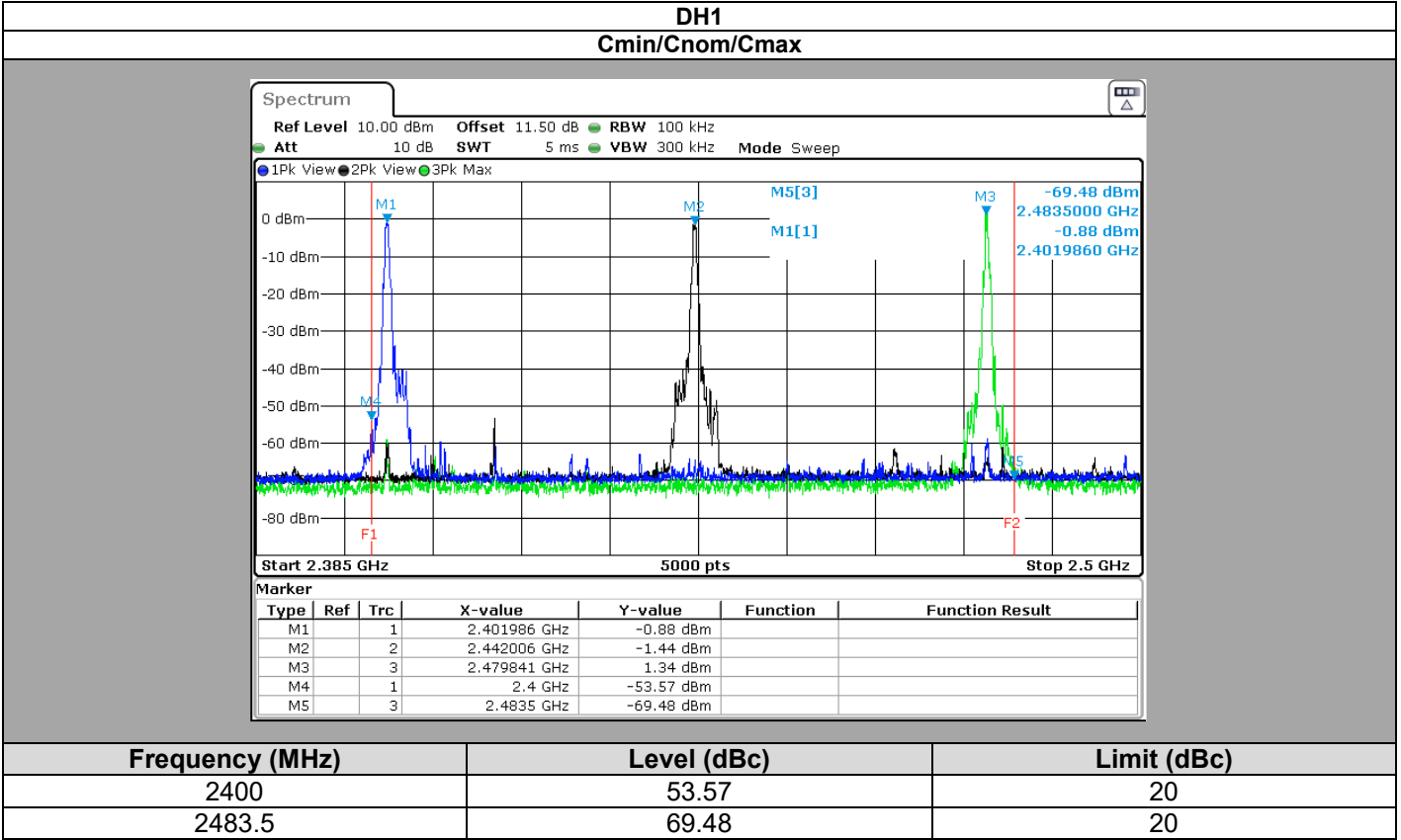



L C I E

2-DH1

Cmin/Cnom/Cmax

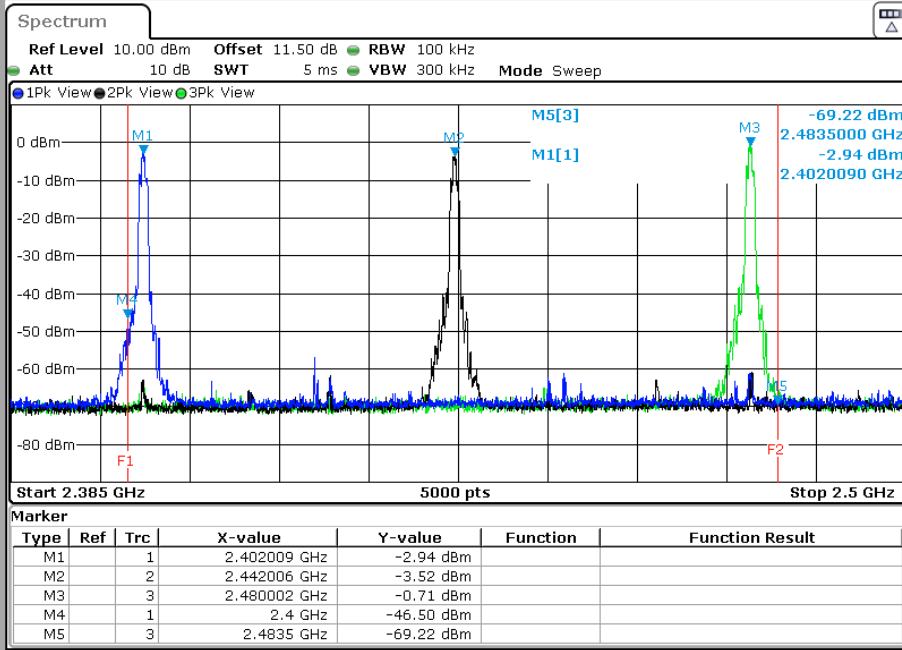

Frequency (MHz)	Level (dBc)	Limit (dBc)
2400	46.50	20
2483.5	69.22	20



L C I E

3-DH1

Cmin/Cnom/Cmax

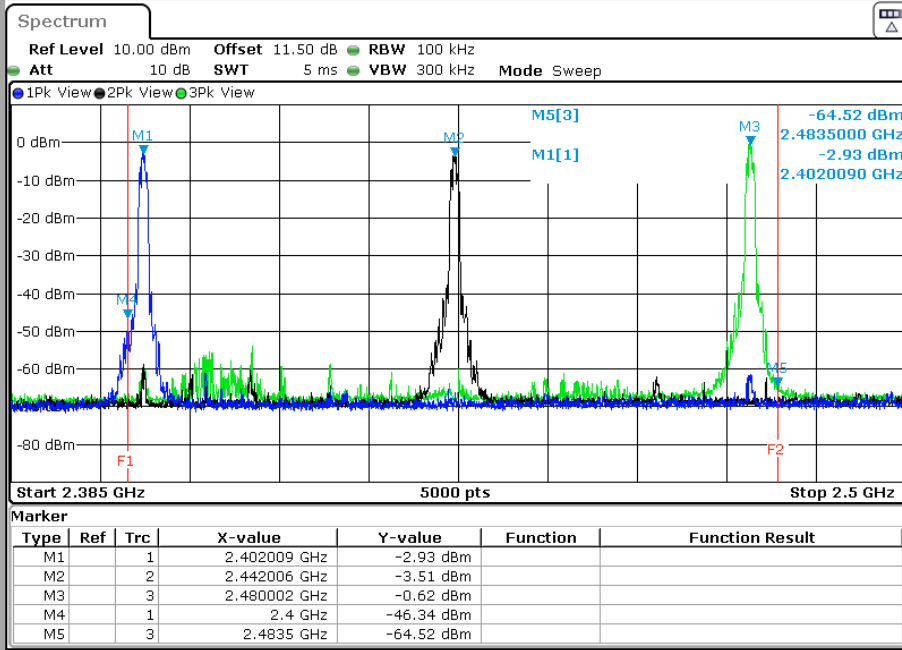

Frequency (MHz)	Level (dBc)	Limit (dBc)
2400	46.34	20
2483.5	64.52	20



L C I E

DH3

Cmin/Cnom/Cmax

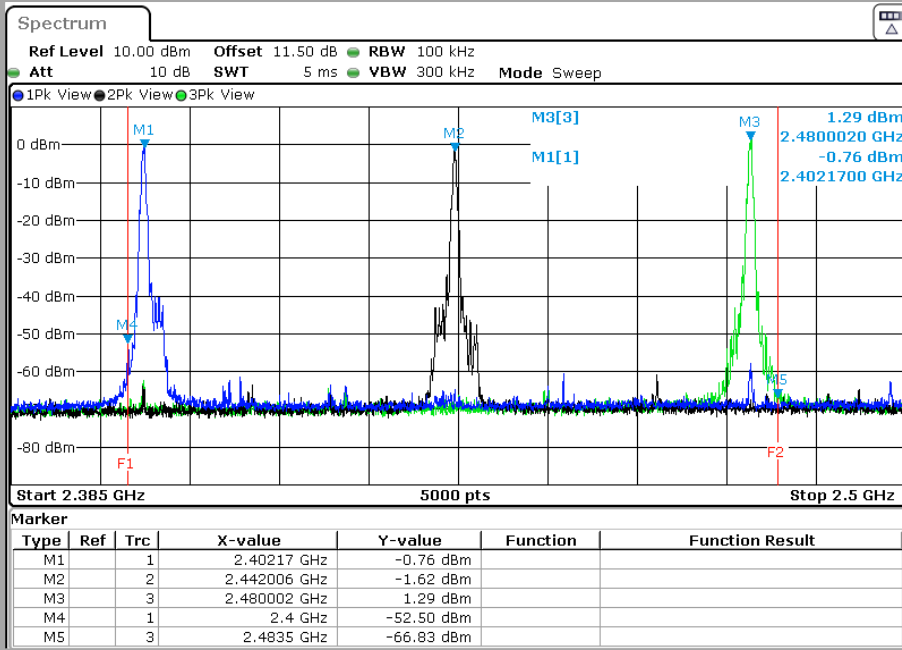

Frequency (MHz)	Level (dBc)	Limit (dBc)
2400	52.50	20
2483.5	66.83	20



L C I E

2-DH3

Cmin/Cnom/Cmax

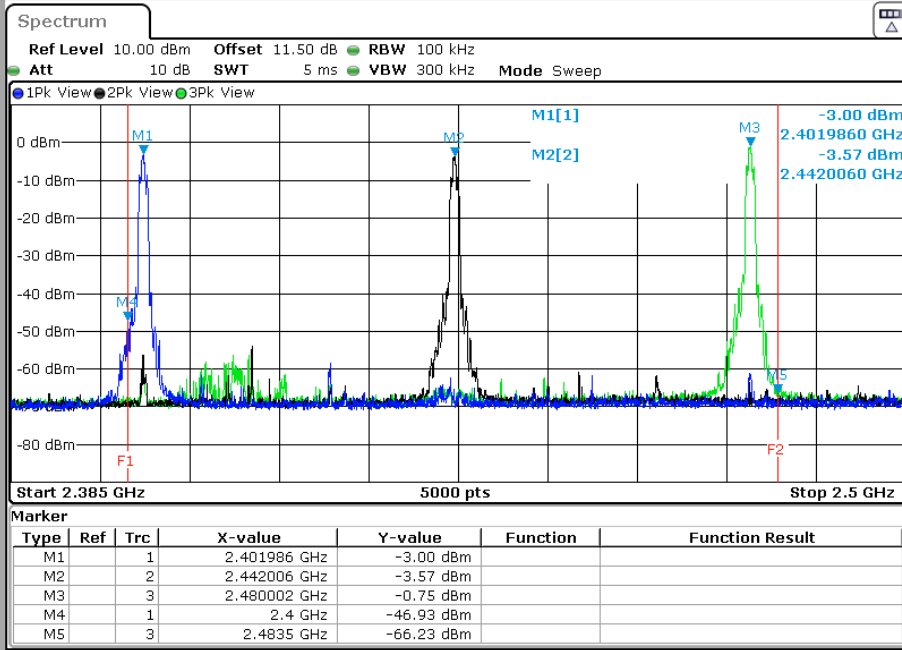

Frequency (MHz)	Level (dBc)	Limit (dBc)
2400	46.93	20
2483.5	66.23	20



L C I E

3-DH3

Cmin/Cnom/Cmax

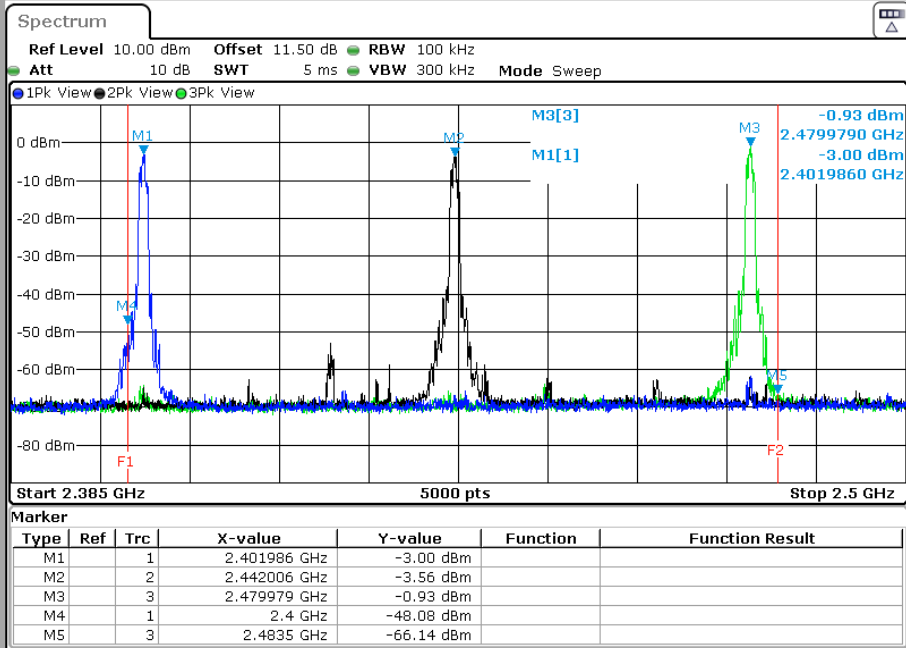

Frequency (MHz)	Level (dBc)	Limit (dBc)
2400	48.08	20
2483.5	66.14	20



L C I E

DH5

Cmin/Cnom/Cmax

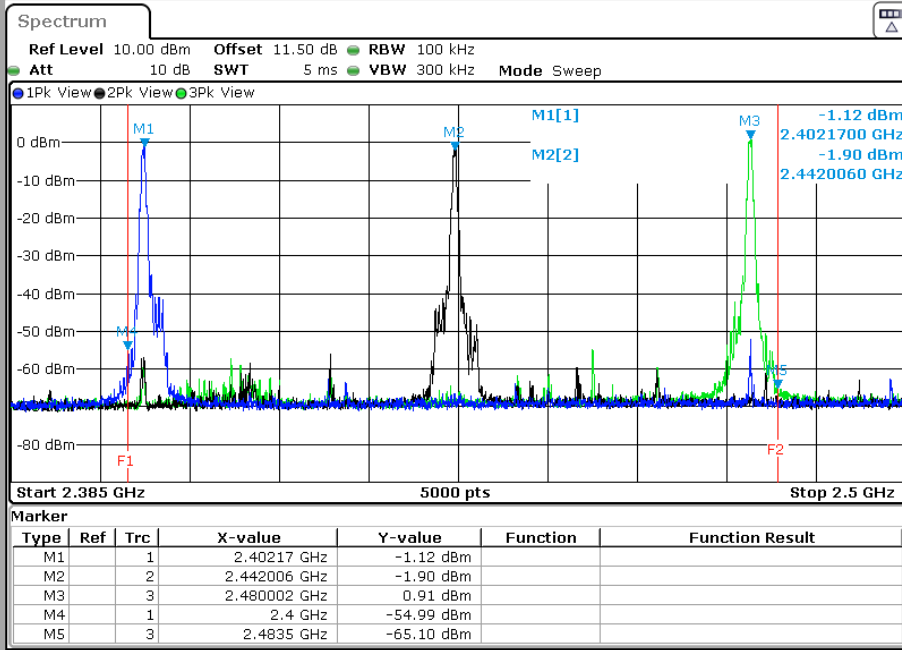

Frequency (MHz)	Level (dBc)	Limit (dBc)
2400	54.99	20
2483.5	65.10	20



L C I E

2-DH5
Cmin/Cnom/Cmax

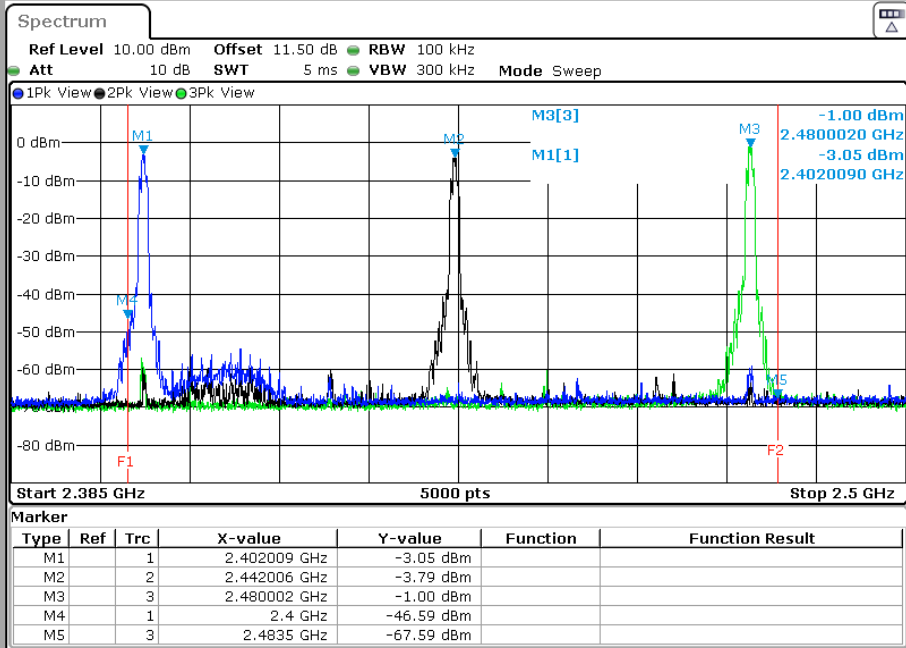

Frequency (MHz)	Level (dBc)	Limit (dBc)
2400	46.59	20
2483.5	67.59	20



L C I E

3-DH5
Cmin/Cnom/Cmax

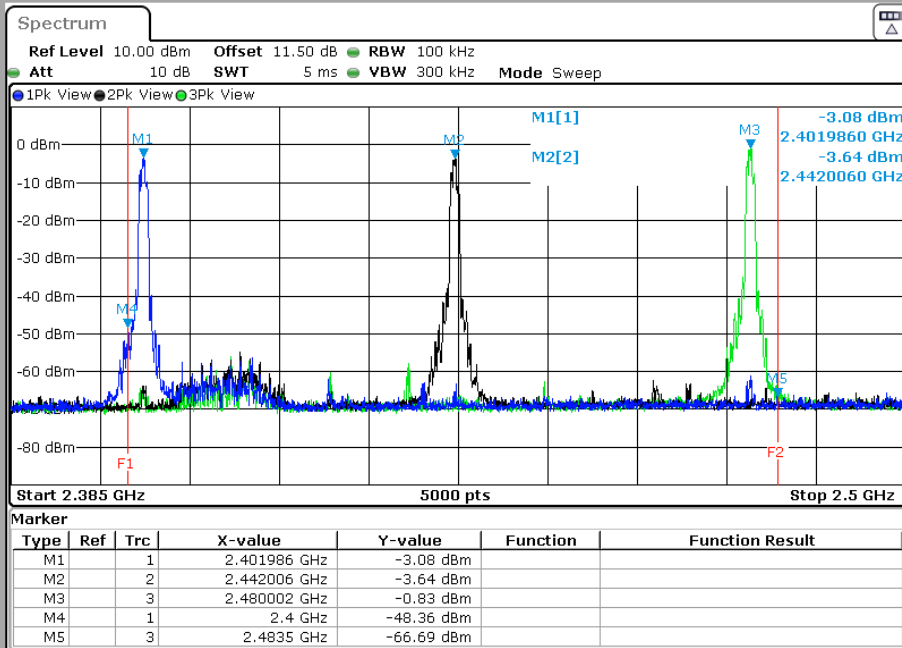

Frequency (MHz)	Level (dBc)	Limit (dBc)
2400	48.36	20
2483.5	66.69	20

9.6. CONCLUSION

Unwanted Emission into non-restricted frequency bands at the band edge measurement performed on the sample of the product **INGENICO Self/0451**, SN: **17055221314115110700000**, in configuration and description presented in this test report, show levels compliant to the **47 CFR PART 15.247 & RSS 247 ISSUE 2** limits.

10. UNWANTED EMISSIONS INTO NON-RESTRICTED FREQUENCY BANDS

10.1. TEST CONDITIONS

Test performed by : Gaetan DESCHAMPS
Date of test : October 21, 2019
Ambient temperature : 23 °C
Relative humidity : 32 %

10.2. TEST SETUP

- The Equipment under Test is installed:

- On a table
- In an anechoic chamber

- Measurement is performed with a spectrum analyzer in:

- Conducted Method
- Radiated Method

Packet type: 1-DH5 / 2-DH5 / 3-DH5 Worst case presented

- Test Procedure:

- ANSI C63.10 § 7.8.8

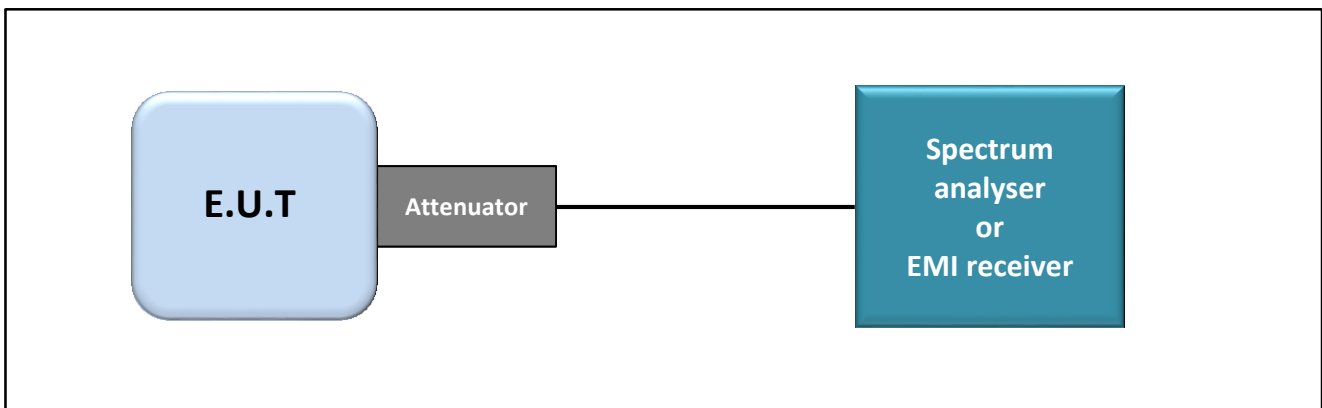

Test set up of Unwanted Emissions into Non-Restricted Frequency Bands



L C I E

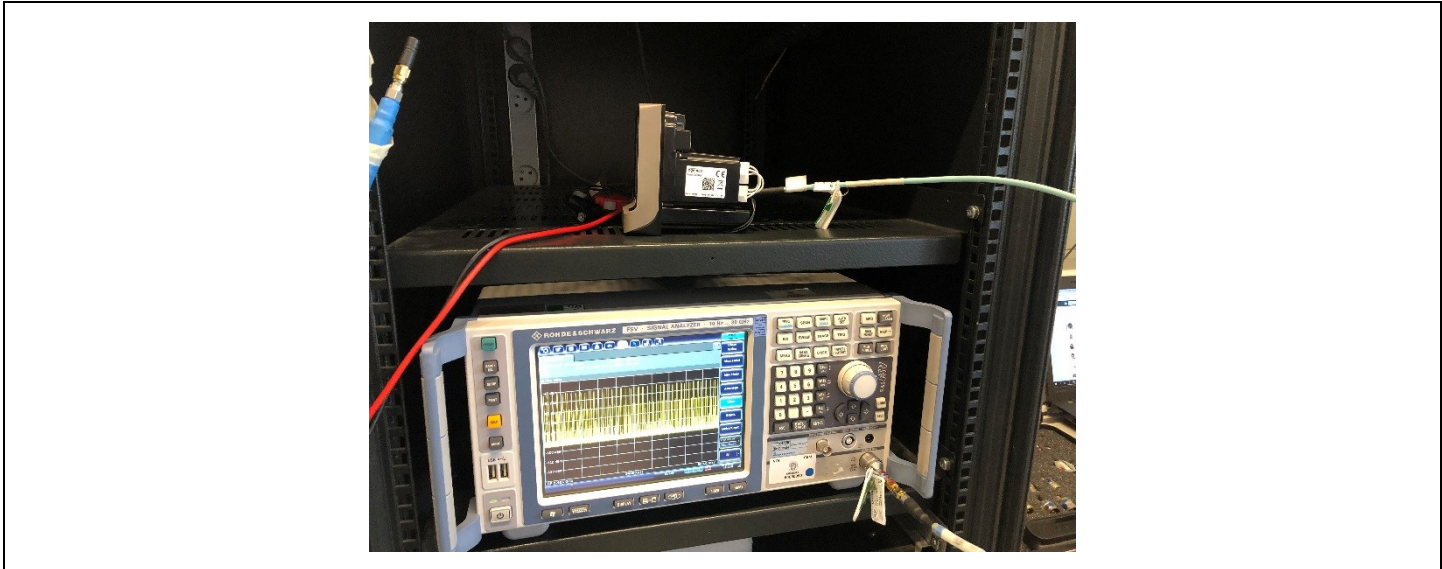

Photograph for Unwanted Emission into non-restricted frequency bands

10.3. LIMIT

All Spurious Emissions must be at least 20 below the Fundamental Radiator Level

10.4. TEST EQUIPMENT LIST

TEST EQUIPMENT USED					
Description	Manufacturer	Model	Identifier	Last Calibration date	Calibration due date
Cable Measure	-	36G	A5329604	02/19	02/20
Attenuator 10dB	AEROFLEX	-	A7122269	12/18	12/19
Bluetooth Tester	ROHDE & SCHWARZ	CBT	A2440007		
SMA 1.5m	SUCOFLEX	18GHz	A5329864	11/18	11/19
Attenuator 10dB	WA	INA 265B	A7122274	09/17	09/19
Thermo-hygrometer (PM1/2/3)	KIMO	HQ 210	B4206022	08/18	08/20
Spectrum analyzer	ROHDE & SCHWARZ	FSV 30	A4060050	12/17	12/19
AC source 1kW	KEYSIGHT	AC6802A	A7042305		
Multimeter	FLUKE	289	A1241119	11/18	11/20
Antenna 2.4GHz	-	SMA	C2040219	-	-

Note: In our quality system, the test equipment calibration due is more & less 2 months



L C I E

10.5. RESULTS

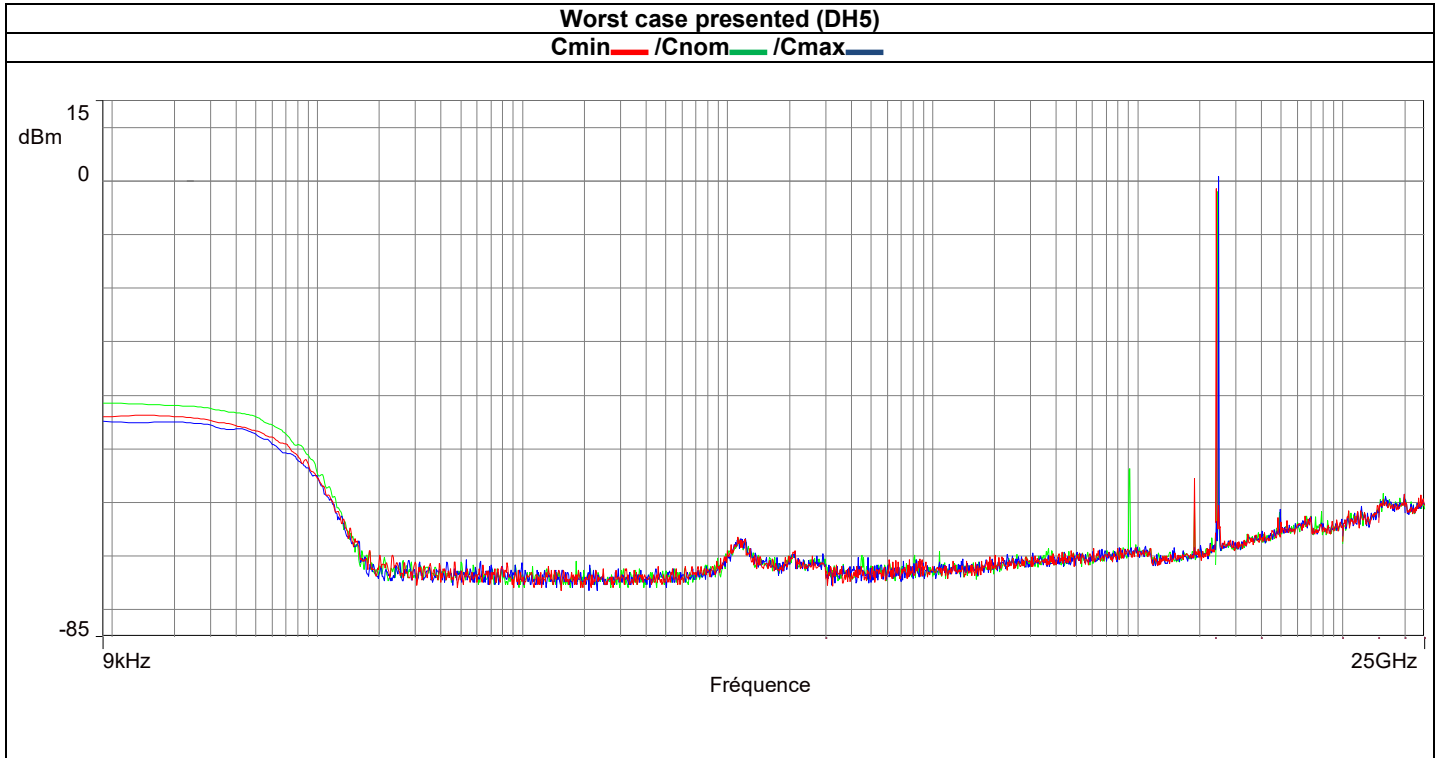

Frequency (MHz)	Level (dBm)	Level (dBc)	Limit (dBc)
914.24	-53.606	-52.185	20
1893.61	-55.538	-54.117	20
2402.00	-1.421		
2442.00	-1.600		
2480.00	0.800		
4804.00	-62.78	-63.580	20

10.6. CONCLUSION

Unwanted Emission into non-restricted frequency bands measurement performed on the sample of the product **INGENICO Self/0451**, SN: **17055221314115110700000**, in configuration and description presented in this test report, show levels **Select Result** to the **47 CFR PART 15.247 & RSS 247 ISSUE 2** limits.

11. AC POWER LINE CONDUCTED EMISSIONS

11.1. TEST CONDITIONS

Test performed by : Jonathan SARTO
 Date of test : September 19, 2019
 Ambient temperature : 22 °C
 Relative humidity : 50 %

11.2. TEST SETUP

The product has been tested according to ANSI C63.10 (2013) method. The EUT is placed on the ground reference plane, at 80cm from the LISN. The distance between the EUT and the vertical ground plane is 40cm. Auxiliaries are powered by another LISN. The cable has been shorted to 1meter length. The EUT is powered through the LISN. Measurement is made with a receiver in peak mode. This was followed by a Quasi-Peak, i.e. CISPR measurement for any strong signal. If the average limit is met when using a Quasi-Peak detector, the EUT shall be deemed to meet both limits and measurement with the average detector is unnecessary. The LISN (measure) is 50Ω / 50μH. Interconnecting cables and equipment's were moved to position that maximized emission.

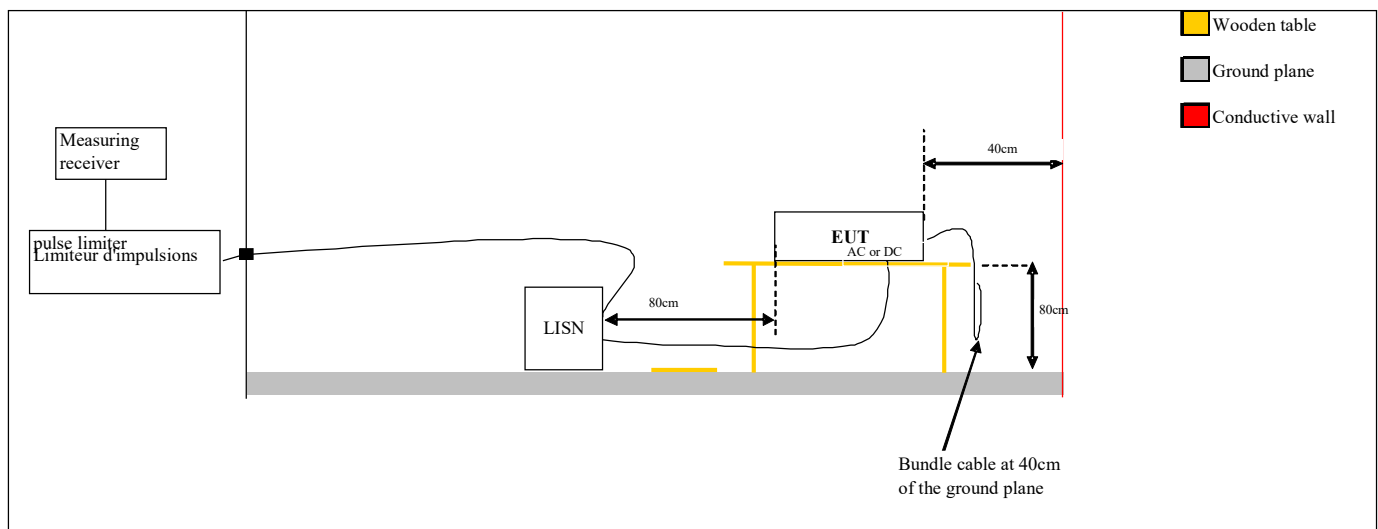

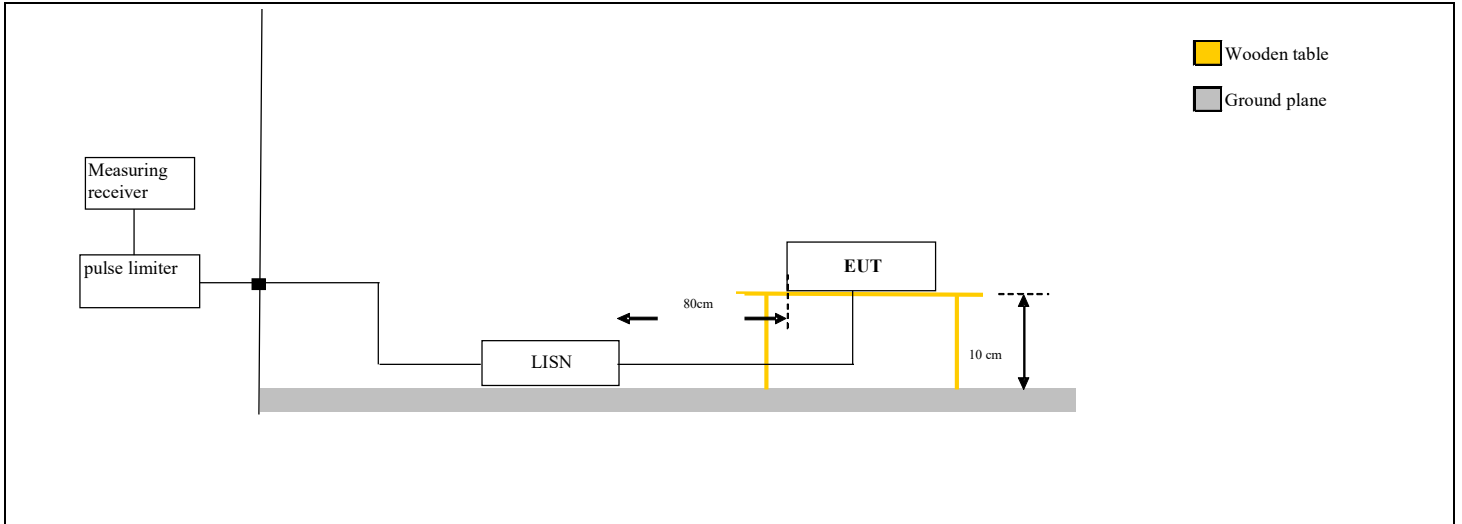

Test set up of AC Power Line Conducted Emissions



Photograph for AC Power Line Conducted Emissions (Front view)

11.3. LIMIT

Frequency range	Level	Detector
0,15kHz to 0,5MHz	66dB μ V to 56 μ V*	QPeak
	56dB μ V to 46 μ V*	Average
0,5MHz to 5MHz	56dB μ V	QPeak
	46dB μ V	Average
5MHz to 30MHz	60B μ V	QPeak
	50dB μ V	Average

*Decreases with the logarithm of the frequency

11.4. TEST EQUIPMENT LIST

TEST EQUIPMENT USED					
Description	Manufacturer	Model	Identifier	Cal date	Due date
BAT EMC	NEXIO	v3.9.0.10	L1000115		
Cable + self			A5329578	10/18	10/19
EMC comb generator	LCIE SUD EST		A3169098		
LISN	ROHDE & SCHWARZ	ENV216	C2320123	05/19	05/20
LISN	ROHDE & SCHWARZ	ENV216	C2320291	02/19	02/20
Spectrum Analyzer 9kHz - 30MHz	ROHDE & SCHWARZ	ESHS10	A2642028	11/17	11/19
Thermo-hygrometer (PM1/2/3)	KIMO	HQ 210	B4206022	08/18	08/20
Transient limiter	ROHDE & SCHWARZ	ESH3-Z2	A7122204	02/19	02/20
Load 50 Ω - N	AEROFLEX		A7152067	02/19	02/20

Note: In our quality system, the test equipment calibration due is more & less 2 months

11.5. DIVERGENCE, ADDITION OR SUPPRESSION ON THE TEST SPECIFICATION

None Divergence:

11.6. RESULTS

AC tests Results:

Measurements are performed on the phase (L1) and neutral (N) of the power line.

Results: (PEAK detection)

Graph identifier	Line	Comments
*Emc# 1	Phase	120VAC/60Hz See below
*Emc# 2	Neutral	120VAC/60Hz See below
*Emc# 3	Phase	240VAC/50Hz See below
*Emc# 4	Neutral	240VAC/50Hz See below

*see the EMC report: 163285-741959-A (FILE#1029087)



L C I E

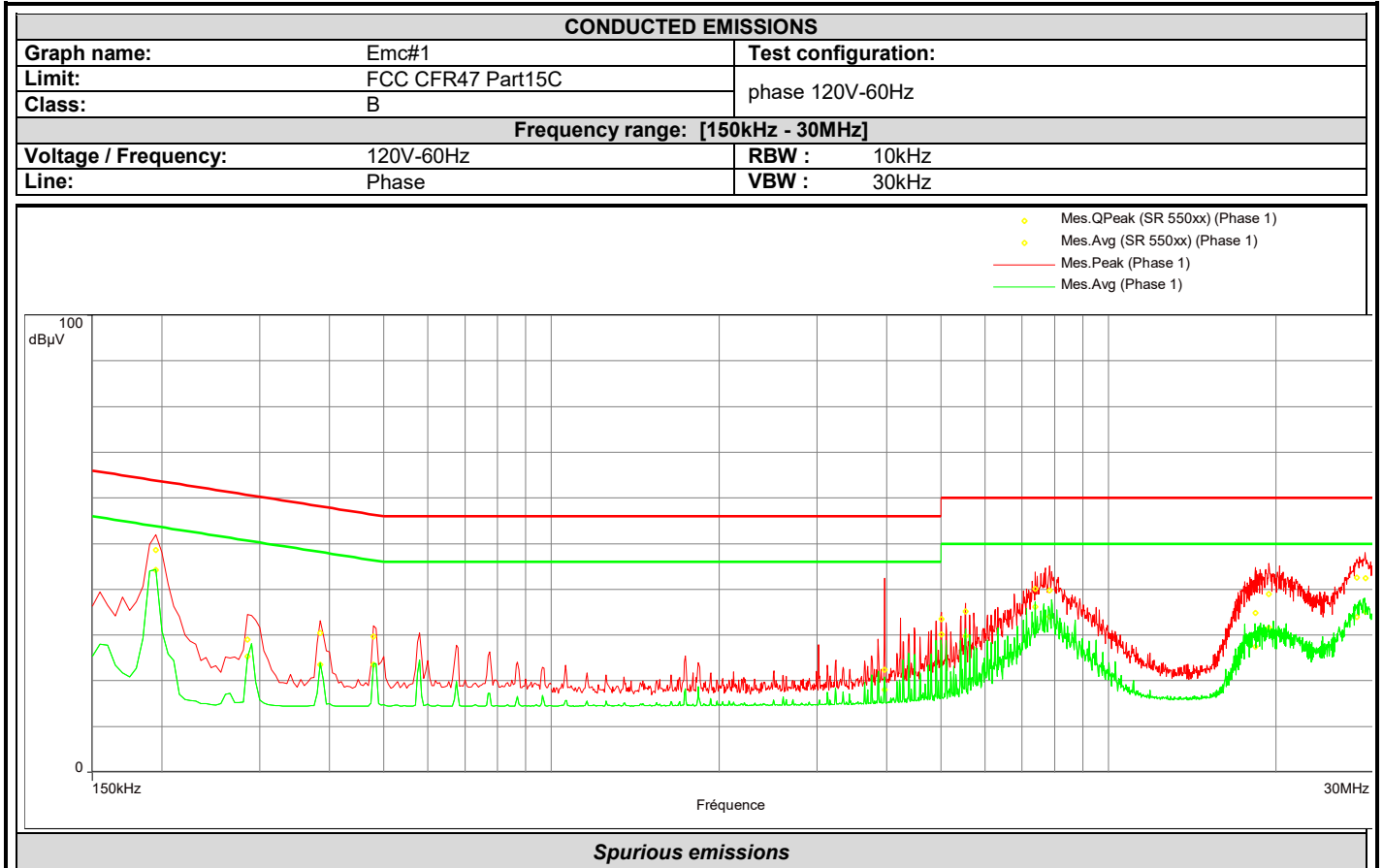

Frequency (MHz)	Mes.QPeak (dBµV)	LimQP (dBµV)	Mes.QPeak-LimQP (dB)	Mes.Avg (dBµV)	LimAvg (dBµV)	Mes.Avg-LimAvg (dB)	Correction (dB)
0.195	48.6	63.8	-15.2	44.2	53.8	-9.6	19.5
0.285	29.0	60.7	-31.6	25.3	50.7	-25.4	19.4
0.385	30.4	58.2	-27.7	23.5	48.2	-24.7	19.4
0.480	29.7	56.3	-26.7	23.5	46.3	-22.8	19.5
3.965	22.4	56.0	-33.6	18.1	46.0	-27.9	19.8
5.015	33.5	60.0	-26.5	30.1	50.0	-19.9	19.9
5.540	35.1	60.0	-24.9	29.8	50.0	-20.2	19.9
7.390	40.1	60.0	-19.9	36.2	50.0	-13.8	20.1
7.845	39.8	60.0	-20.2	34.0	50.0	-16.0	20.1
18.365	34.8	60.0	-25.2	27.4	50.0	-22.6	20.8
19.395	39.0	60.0	-21.0	31.6	50.0	-18.4	20.9
27.915	42.6	60.0	-17.4	34.0	50.0	-16.0	21.4
28.915	42.4	60.0	-17.6	35.0	50.0	-15.0	21.4



L C I E

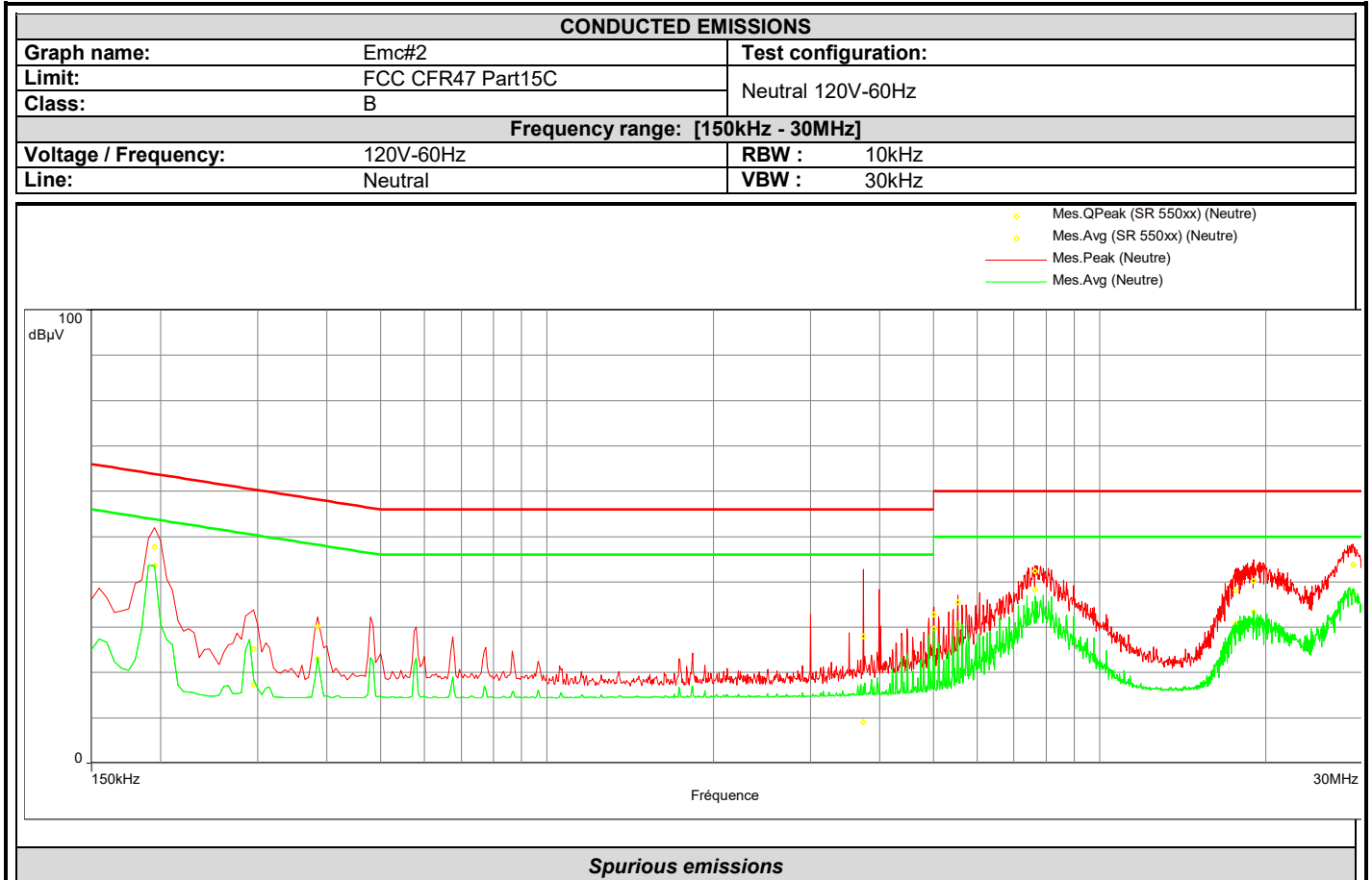

Frequency (MHz)	Mes.QPeak (dBµV)	LimQP (dBµV)	Mes.QPeak-LimQP (dB)	Mes.Avg (dBµV)	LimAvg (dBµV)	Mes.Avg-LimAvg (dB)	Correction (dB)
0.195	47.8	63.8	-16.1	43.5	53.8	-10.3	19.5
0.295	25.2	60.4	-35.2	17.4	50.4	-33.0	19.4
0.385	30.1	58.2	-28.0	22.9	48.2	-25.3	19.4
3.740	28.0	56.0	-28.0	9.1	46.0	-36.9	19.8
5.015	32.8	60.0	-27.2	29.7	50.0	-20.3	19.9
5.540	35.5	60.0	-24.5	30.6	50.0	-19.4	19.9
7.650	42.3	60.0	-17.7	38.3	50.0	-11.7	20.1
17.645	38.1	60.0	-21.9	30.8	50.0	-19.2	20.8
18.995	40.2	60.0	-19.8	33.4	50.0	-16.6	20.9
28.730	43.8	60.0	-16.2	37.7	50.0	-12.3	21.4



L C I E

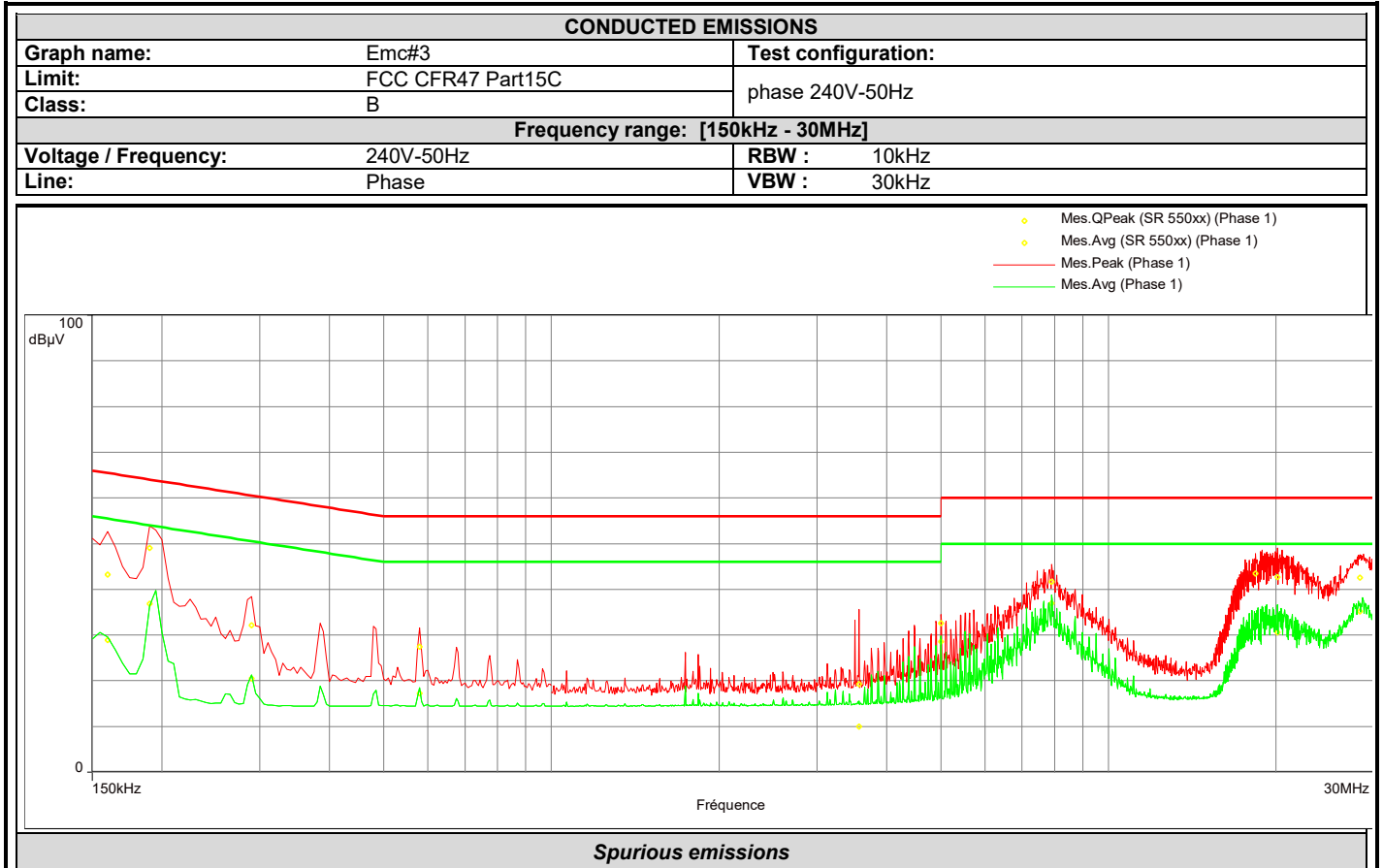

Frequency (MHz)	Mes.QPeak (dBµV)	LimQP (dBµV)	Mes.QPeak-LimQP (dB)	Mes.Avg (dBµV)	LimAvg (dBµV)	Mes.Avg-LimAvg (dB)	Correction (dB)
0.160	43.2	65.5	-22.2	28.9	55.5	-26.6	19.4
0.190	49.1	64.0	-15.0	36.9	54.0	-17.2	19.5
0.290	32.1	60.5	-28.4	20.5	50.5	-30.1	19.4
0.580	27.5	56.0	-28.5	17.2	46.0	-28.8	19.5
3.565	19.2	56.0	-36.8	10.0	46.0	-36.0	19.7
5.010	32.6	60.0	-27.4	28.6	50.0	-21.4	19.9
7.915	41.6	60.0	-18.4	37.0	50.0	-13.0	20.1
18.370	43.5	60.0	-16.5	31.9	50.0	-18.1	20.8
20.105	42.7	60.0	-17.3	30.6	50.0	-19.4	21.0
28.260	42.5	60.0	-17.5	35.2	50.0	-14.8	21.4



L C I E

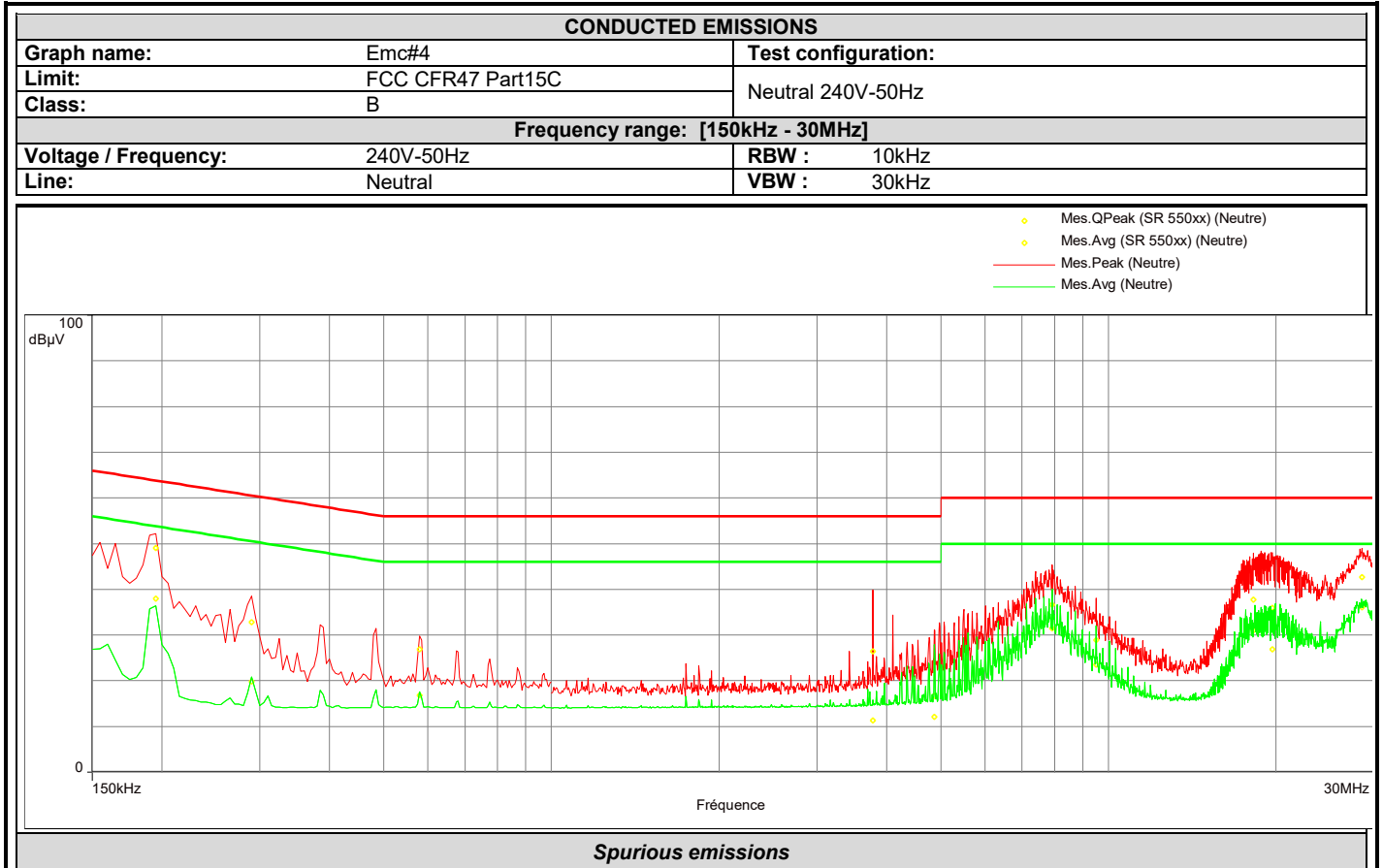

Frequency (MHz)	Mes.QPeak (dBµV)	LimQP (dBµV)	Mes.QPeak-LimQP (dB)	Mes.Avg (dBµV)	LimAvg (dBµV)	Mes.Avg-LimAvg (dB)	Correction (dB)
0.195	49.0	63.8	-14.8	38.0	53.8	-15.8	19.5
0.290	32.8	60.5	-27.7	19.9	50.5	-30.7	19.4
0.580	26.9	56.0	-29.1	16.8	46.0	-29.2	19.5
3.780	26.4	56.0	-29.6	11.3	46.0	-34.7	19.8
4.870	16.7	56.0	-39.3	12.1	46.0	-33.9	19.8
7.925	36.7	60.0	-23.3	31.5	50.0	-18.5	20.1
9.510	28.9	60.0	-31.1	23.6	50.0	-26.4	20.2
18.210	37.7	60.0	-22.3	31.0	50.0	-19.0	20.8
19.670	35.9	60.0	-24.1	26.9	50.0	-23.1	20.9
28.485	42.7	60.0	-17.3	36.0	50.0	-14.0	21.4

11.7. CONCLUSION

Ac Power Line Conducted Emission measurement performed on the sample of the product **INGENICO Self/0451**, SN: **1705522131411511070000**, in configuration and description presented in this test report, show levels **compliant** to the 47 CFR PART 15.247 & RSS 247 ISSUE 2 limits.

12. UNWANTED EMISSIONS IN RESTRICTED FREQUENCY BANDS

12.1. TEST CONDITIONS

Test performed by	: Gaetan DESCHAMPS	: Jonathan SARTO
Date of test	: October 11, 2019	: September 20, 2019
Ambient temperature	: 23 °C	: 21 °C
Relative humidity	: 32 %	: 50 %

12.2. TEST SETUP

Test is performed in horizontal (H) and vertical (V) polarization with **bilog** between 30MHz & 1GHz and with a horn antenna above 1GHz. Measurement bandwidth was 120kHz below 1GHz and 1MHz above 1GHz. The level has been maximised by the turntable rotation of 360 degrees range on the 3 axis of EUT. Antenna height search was performed from 1 to 4m. The EUT is place at 1.5m high above 1GHz and at 0.8m high under 1GHz. The EUT is placed **in a full anechoic chamber** above 1GHz and **on an open area test site** from 30MHz to 1GHz. Distance between measuring antenna and the EUT is **3m**.

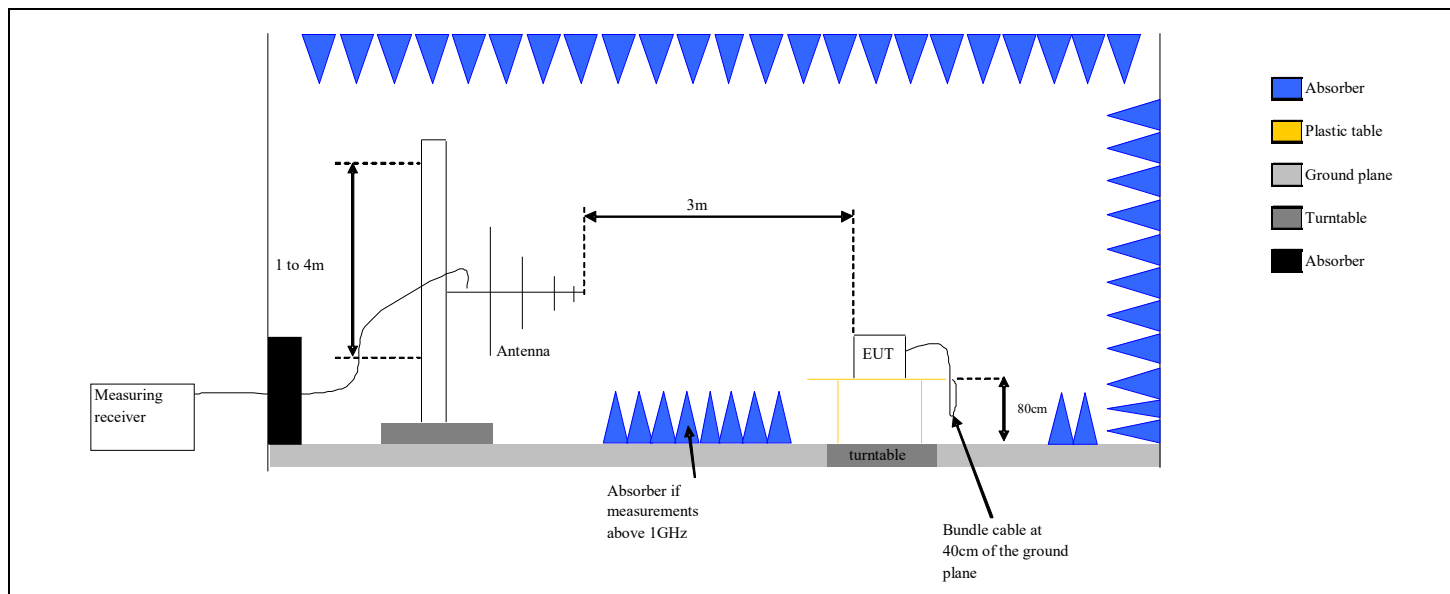

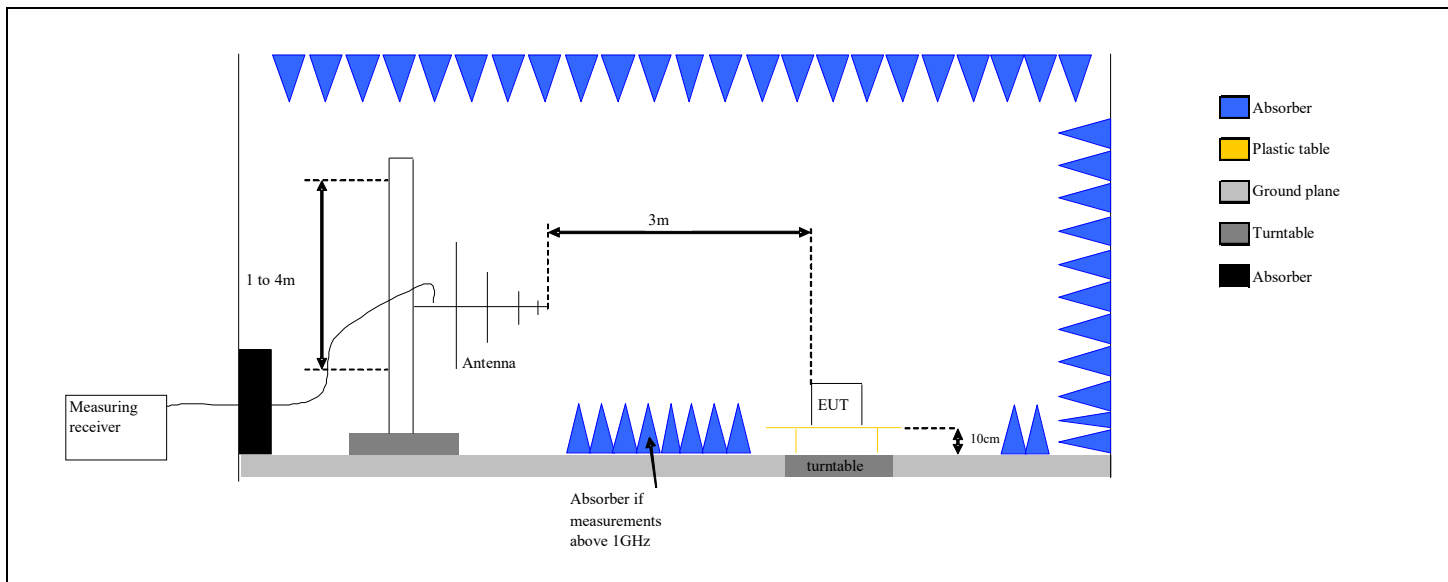

Test set up of Unwanted Emissions in Restricted Frequency Bands in semi anechoic chamber

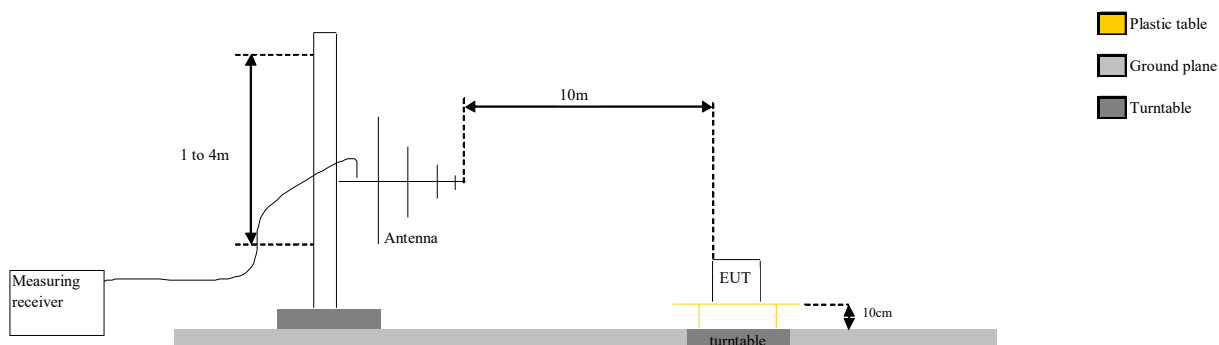
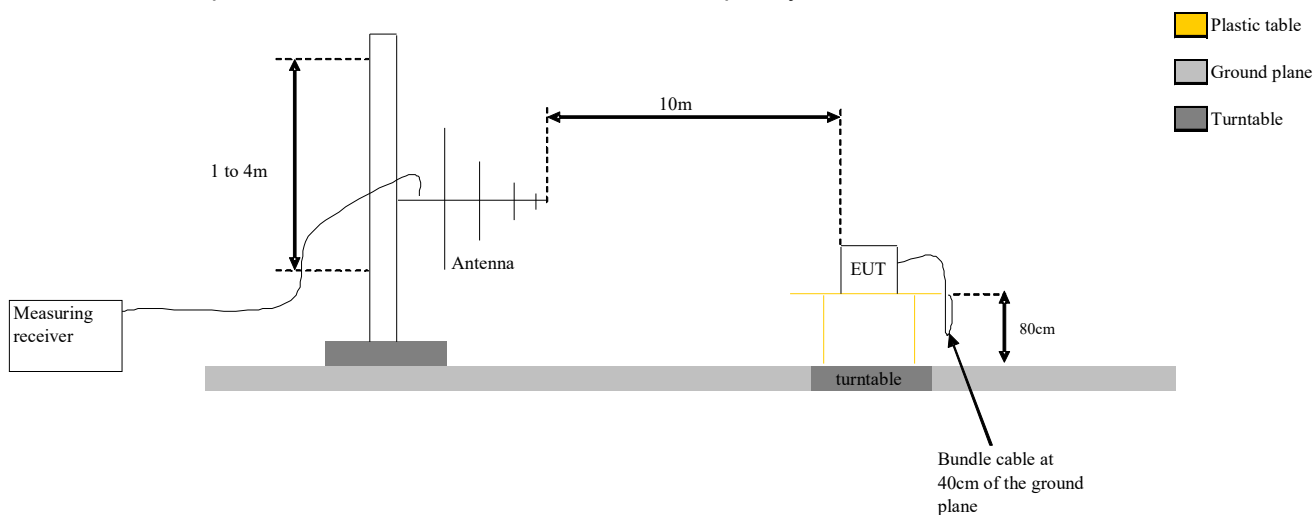

Test Set up for radiated measurement in open area test site



Test setup on OATS(30MHz-1GHz)

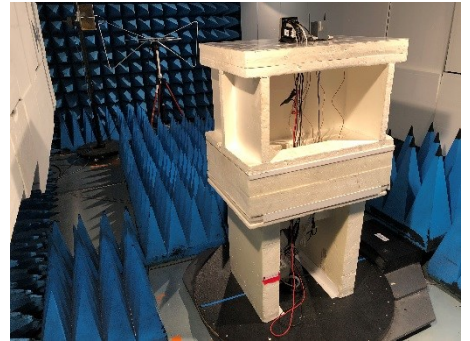
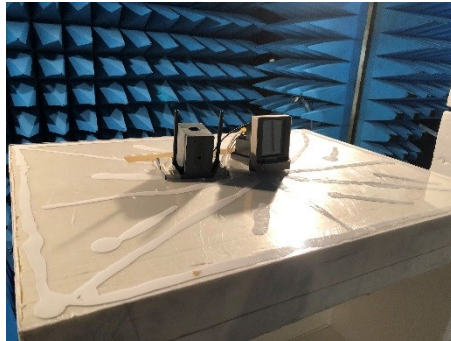

Test setup in axis XY (only one antenna position)

Photograph for Unwanted Emission in restricted frequency bands



L C I E

12.3. LIMIT

Measure at 300m		
Frequency range	Level	Detector
9kHz-490kHz	67.6dB μ V/m /F(kHz)	QPeak
Measure at 30m		
Frequency range	Level	Detector
490kHz-1.705MHz	87.6dB μ V/m /F(kHz)	QPeak
1.705MHz-30MHz	29.5dB μ V/m	QPeak
Measure at 10m		
Frequency range	Level	Detector
30MHz to 88MHz	29.5dB μ V/m	QPeak
88MHz to 216MHz	33dB μ V/m	QPeak
216MHz to 960MHz	35.5B μ V/m	QPeak
960MHz to 1000MHz	43.5dB μ V/m	QPeak
Above 1000MHz	63.5dB μ V/m	Peak
	43.5dB μ V/m	Average
Measure at 3m		
Frequency range	Level	Detector
30MHz to 88MHz	40dB μ V/m	QPeak
88MHz to 216MHz	43.5dB μ V/m	QPeak
216MHz to 960MHz	46B μ V/m	QPeak
960MHz to 1000MHz	54dB μ V/m	QPeak
Above 1000MHz	74dB μ V/m	Peak
	54dB μ V/m	Average

12.4. TEST EQUIPMENT LIST

Test setup for frequency range 1-26GHz :

TEST EQUIPMENT USED					
Description	Manufacturer	Model	Identifier	Last Calibration date	Calibration due date
Amplifier 9kHz - 40GHz	LCIE SUD EST	-	A7102082	10/18	10/19
Antenna horn 18GHz	EMCO	3115	C2042029	09/18	09/20
High Pass (4.8-18GHz)	BL Microwave	SH4800-1800	A7484034	08/19	08/21
Spectrum analyzer	ROHDE & SCHWARZ	FSV 30	A4060051	03/18	03/20
BAT EMC	NEXIO	v3.17.0.10	L1000115	-	-
Emission Cable (Cage <-> Antenna)	-	18GHz	A5329562	02/19	02/20
Emission Cable (SMA 1m)	TELEDYNE	26GHz	A5329874	01/19	01/20
Emission Cable (SMA 3.3m)	TELEDYNE	26GHz	A5329875	01/19	01/20
Emission Cable (SMA 30cm)	TELEDYNE	26GHz	A5329873	01/19	01/20
Emission Cable <1GHz (Ampl <-> Cage)	-	18GHz	A5329907	08/19	08/20
Semi-Anechoic chamber #3 (BF)	SIEPEL	-	D3044017_BF	03/17	03/20
Semi-Anechoic chamber #3 (VSWR)	SIEPEL	-	D3044017_VSWR	03/17	03/20
Antenna Bi-Log	CHASE	UPA6192	C2040221	01/18	01/20
Thermo-hygrometer (C3)	OREGON	BAR206	B4204078	10/18	10/20
Thermo-hygrometer (PM1/2/3)	KIMO	HQ 210	B4206022	08/18	08/20
Turntable chamber (Cage#3)	ETS Lingren	Model 2165	F2000371	-	-
Table C3	LCIE	-	F2000461	-	-
Rehausse Table C3	LCIE	-	F2000511	-	-
Turntable controller (Cage#3)	ETS Lingren	Model 2090	F2000444	-	-
Antenna 960-2500MHz	-	WH-GSM-D7	C2040218		
Bluetooth Tester	ROHDE & SCHWARZ	CBT	A2440007		
Cable Gén�	-	18GHz	A5329045	03/19	03/20
Cable Gén�	-	-	A5329590	11/18	11/19

Note: In our quality system, the test equipment calibration due is more & less 2 months



Test setup for frequency range 30M-1GHz :

TEST EQUIPMENT USED					
Description	Manufacturer	Model	Identifier	Cal date	Due date
Amplifier 100kHz - 18GHz	LCIE SUD EST		A7085027	07/19	07/20
Antenna Bi-log	AH System	SAS-521-7	C2040180	10/18	10/20
Antenna mast (Cage#1)	MATURO Gmbh	AM 4.0	F2000407		
BAT EMC	NEXIO	v3.9.0.10	L1000115		
Cable 0.75m	SUCOFLEX	18GHz	A5329920	09/19	09/20
Cable 2m	-	18GHz	A5329904	08/19	08/20
Emission Cable	SUCOFLEX	18GHz	A5329899	07/19	07/20
Radiated emission comb generator	BARDET		A3169050		
Semi-Anechoic chamber #1 (VSWR)	SIEPEL		D3044016 VSWR	07/19	07/22
Spectrum analyzer	ROHDE & SCHWARZ	FSV 30	A4060051	03/18	03/20
Table C1/OATS	MATURO Gmbh		F2000437		
Thermo-hygrometer (PM1/2/3)	KIMO	HQ 210	B4206022	08/18	08/20
Turntable chamber (Cage#1)	MATURO Gmbh	TT 2.0 SI	F2000406		
Turntable controller (Cage#1)	MATURO Gmbh	Control Unit	F2000408		
Antenna Bi-log	CHASE	CBL6111A	C2040051	06/19	06/20
Antenna mast (OATS)	ETS Lingren	2071-2	F2000392		
Cable (OATS)		1GHz	A5329623	03/19	03/20
Emission Cable	SUCOFLEX	6GHz	A5329061	02/19	02/20
OATS			F2000409	02/19	02/20
Receiver 20-1000MHz	ROHDE & SCHWARZ	ESVS30	A2642006	12/17	12/19
Table C2/OATS	LCIE		F2000438		
Turntable (OATS)	ETS Lingren	Model 2187	F2000403		
Turntable / Mast controller (OATS)	ETS Lingren	Model 2066	F2000372		

12.5. DIVERGENCE, ADDITION OR SUPPRESSION ON THE TEST SPECIFICATION

None Divergence:



L C I E

12.6. RESULTS

Worst case measurement presented:

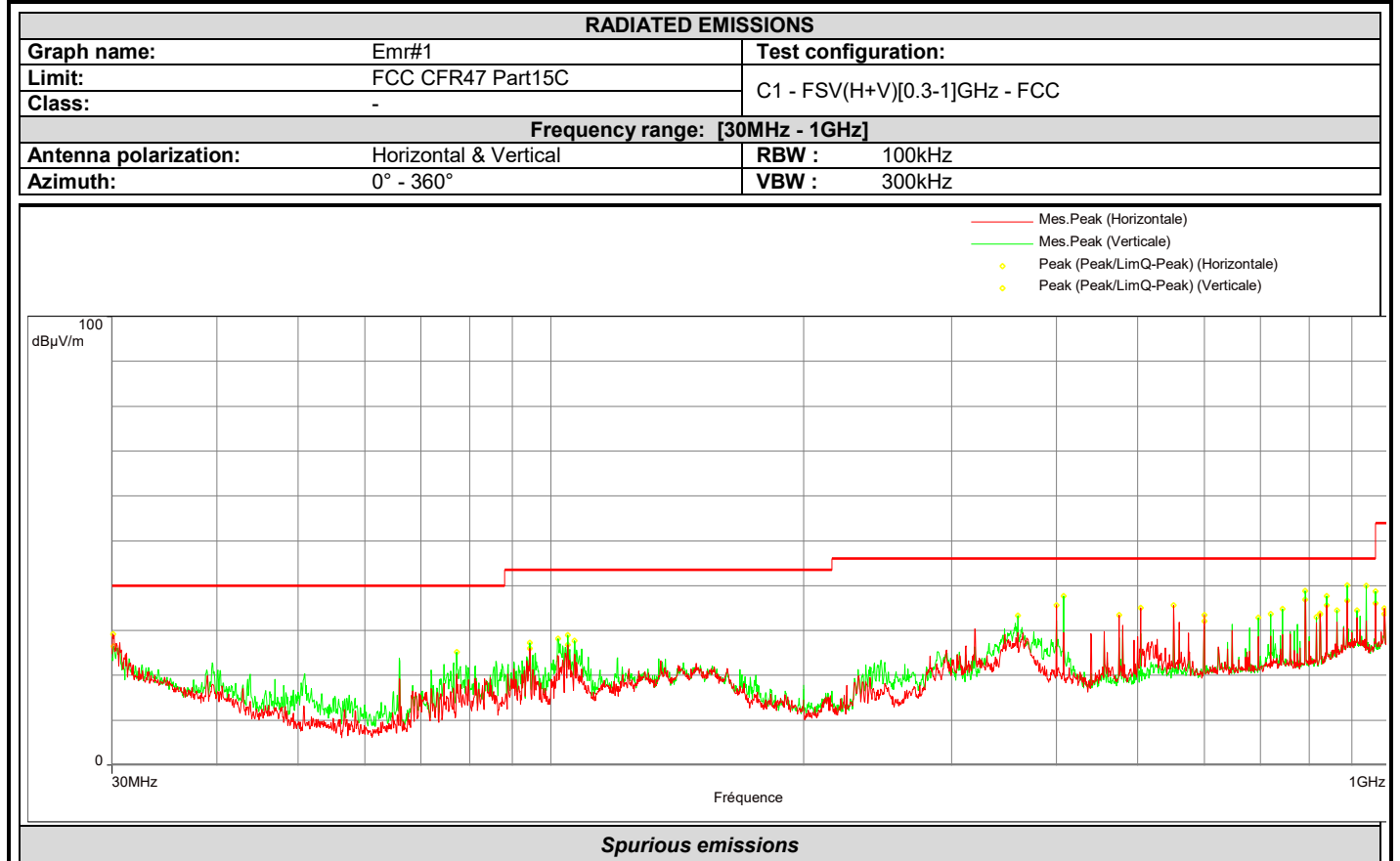

Frequency (MHz)	Peak (dBµV/m)	LimQP (dBµV/m)	Peak-LimQP (dB)	Hauteur (m)	Polarization	Correction (dB)
30.068	29.2	40.0	-10.8	1.6	Horizontal	-6.6
94.396	26.0	43.5	-17.5	1.6	Horizontal	-12.6
104.698	26.8	43.5	-16.7	1.6	Horizontal	-10.6
400.000	35.6	46.0	-10.4	1.6	Horizontal	-6.6
475.000	33.4	46.0	-12.6	1.6	Horizontal	-5.5
504.000	35.1	46.0	-10.9	1.6	Horizontal	-5.2
552.000	35.6	46.0	-10.4	1.6	Horizontal	-4.0
600.000	32.0	46.0	-14.0	1.6	Horizontal	-4.0
600.000	33.4	46.0	-12.6	1.6	Horizontal	-4.0
792.000	36.9	46.0	-9.1	1.6	Horizontal	-2.4
825.040	33.8	46.0	-12.2	1.6	Horizontal	-1.5
840.000	35.6	46.0	-10.4	1.6	Horizontal	-0.8
888.040	36.7	46.0	-9.3	1.6	Horizontal	1.1
960.040	36.1	54.0	-17.9	1.6	Horizontal	2.1
984.000	35.0	54.0	-19.0	1.6	Horizontal	2.9
990.000	34.6	54.0	-19.4	1.6	Horizontal	2.8
30.119	26.4	40.0	-13.6	1.6	Vertical	-6.7
77.192	25.3	40.0	-14.7	1.6	Vertical	-16.2
94.362	27.3	43.5	-16.2	1.6	Vertical	-12.6
101.893	28.2	43.5	-15.3	1.6	Vertical	-11.1
104.749	29.0	43.5	-14.5	1.6	Vertical	-10.6
106.721	27.7	43.5	-15.8	1.6	Vertical	-10.2
360.000	33.4	46.0	-12.6	1.6	Vertical	-9.2
408.000	37.7	46.0	-8.3	1.6	Vertical	-6.7



L C I E

Frequency (MHz)	Peak (dB μ V/m)	LimQP (dB μ V/m)	Peak-LimQP (dB)	Hauteur (m)	Polarization	Correction (dB)
696.000	32.9	46.0	-13.1	1.6	Vertical	-2.9
720.000	33.7	46.0	-12.3	1.6	Vertical	-2.7
743.960	34.8	46.0	-11.2	1.6	Vertical	-2.5
792.000	38.8	46.0	-7.2	1.6	Vertical	-2.4
816.000	33.0	46.0	-13.0	1.6	Vertical	-1.8
825.000	33.5	46.0	-12.5	1.6	Vertical	-1.5
840.000	37.7	46.0	-8.3	1.6	Vertical	-0.8
864.040	34.5	46.0	-11.5	1.6	Vertical	0.1
888.000	40.2	46.0	-5.8	1.6	Vertical	1.1
912.000	34.4	46.0	-11.6	1.6	Vertical	2.1
936.000	40.0	46.0	-6.0	1.6	Vertical	1.5
960.000	38.7	46.0	-7.3	1.6	Vertical	2.1
984.000	33.7	54.0	-20.3	1.6	Vertical	2.9

Worst case measurement observed in OATS (see the EMC report: 163285-741959-A (FILE#1029087))

Test Frequency (MHz)	Meter Reading dB(μ V)	Detector (Pk/QP/Av)	Polarity (V/H)	Azimuth (Degrees)	Antenna Height (cm)	Gain/Loss Factor (dB)	Transducer Factor (dB)	Level (dB μ V/m)	Limit (dB μ V/m)	Margin (dB)	Remark
77.100	21.0	QP	V	100	100	-	8.3	29.3	40.0	-10.7	
94.400	25.3	QP	V	0	100	-	10.9	36.2	43.5	-7.3	Measure performed at 3m
104.700	22.3	QP	V	0	100	-	12.3	34.6	43.5	-8.9	Measure performed at 3m
360.000	14.7	QP	V	260	100	-	18.4	33.1	46.0	-12.9	
400.000	14.8	QP	V	90	190	-	20.2	35.0	46.0	-11.0	
408.000	12.4	QP	V	0	100	-	20.4	32.8	46.0	-13.2	
504.000	13.6	QP	V	0	100	-	22.8	36.4	46.0	-9.6	
552.000	12.8	QP	V	90	100	-	25.1	37.9	46.0	-8.1	
888.000	12.0	QP	V	0	230	-	29.5	41.5	46.0	-4.5	
936.000	10.5	QP				-	31.1	41.6	46.0	-4.4	



L C I E

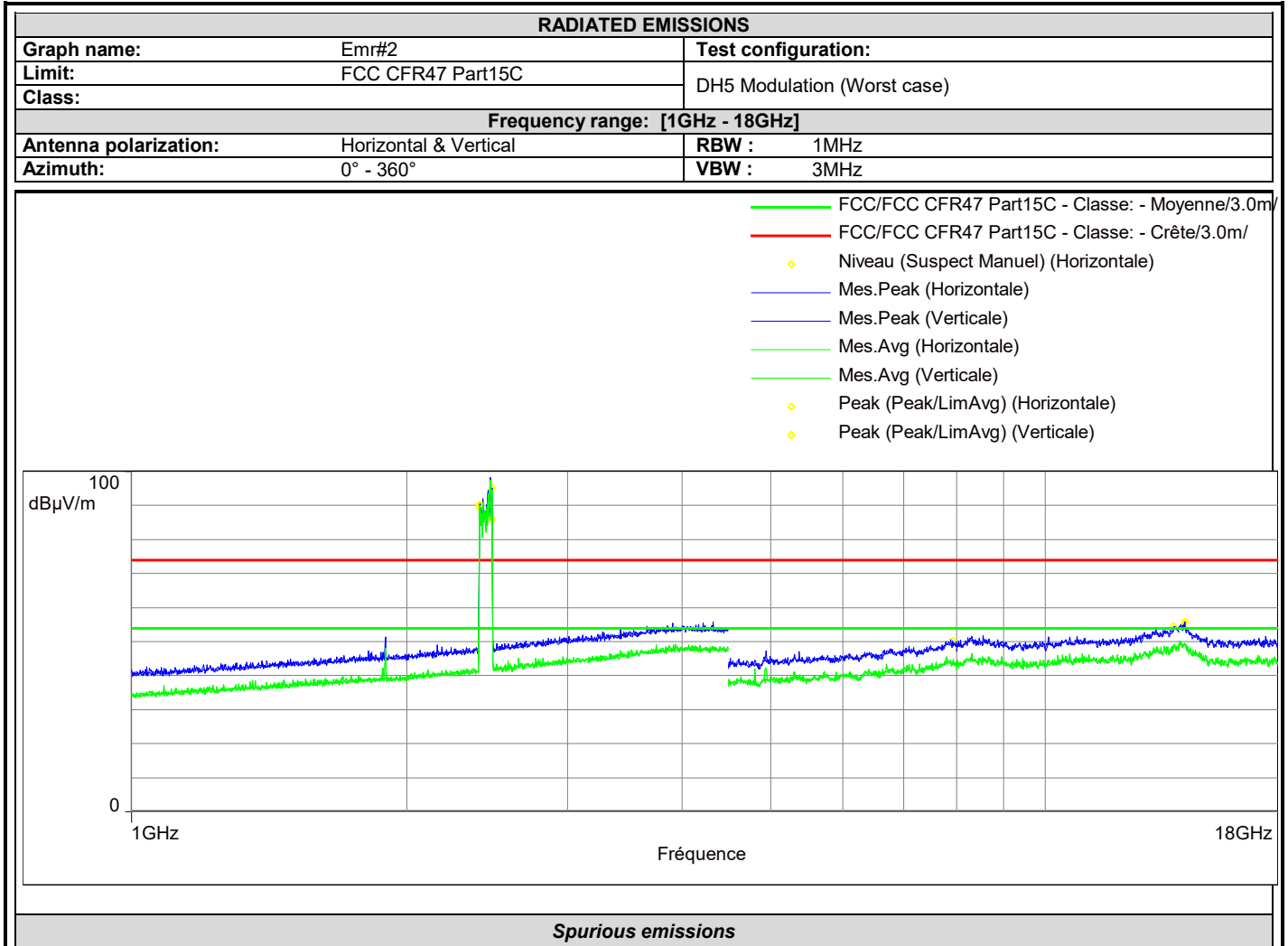

Frequency (MHz)**	Peak (dBµV/m)	LimM (dBµV/m)	Peak-LimM (dB)	Polarization	Correction (dB)
14206.800	55.8	54.0	1.8	Horizontal	1.8
2403.150*	89.6	54.0	35.6	Vertical	33.4
2480.150*	86.1	54.0	32.1	Vertical	33.7
7912.500	50.2	54.0	-3.8	Vertical	-18.5
13818.200	54.4	54.0	0.4	Vertical	2.6
14182.400	55.3	54.0	1.3	Vertical	2.0

*Carrier frequencies

**Worst case, see the following table results.



Worst case measurements :

Test Frequency (MHz)	Level (dB μ V/m)	Detector (Pk/QP/Av)	Polarity (V/H)	Azimuth (Degrees)	Antenna Height (cm)	Gain/Loss Factor (dB)	Transducer Factor (dB)	Limit (dB μ V/m)	Margin (dB)
7912.500	31.7	Pk	V	225	150	-	-19.3	74.0	-23.0
7912.500	21.7	Av	V	225	150	-	-19.3	54.0	-13.0
13818.200	56.5	Pk	V	355	150	-	1.5	74.0	-19.0
13818.200	50.5	Av	V	355	150	-	1.5	54.0	-5.0
14182.400	56.6	Pk	V	250	150	-	0.6	74.0	-18.0
14182.400	47.3	Av	V	250	150	-	0.6	54.0	-7.3
14206.800	56.4	Pk	H	265	150	-	0.6	74.0	-18.2
14206.800	47.1	Av	H	265	150	-	0.6	54.0	-7.5

Results for frequency range [18-26]GHz:

No significant frequency observed.

12.7. CONCLUSION

Unwanted Emission in restricted frequency bands measurement performed on the sample of the product **INGENICO Self/0451**, SN: **17055221314115110700000**, in configuration and description presented in this test report, show levels **compliant** to the 47 CFR PART 15.247 & RSS 247 ISSUE 2 limits.

13. UNCERTAINTIES CHART

Type de mesure / Kind of measurement	Incertitude élargie laboratoire / Wide uncertainty laboratory (k=2) ± x	Incertitude limite du CISPR / CISPR uncertainty limit ± y
Mesure des perturbations conduites en tension sur le réseau d'énergie <i>Measurement of conducted disturbances in voltage on the power port</i>	3.51 dB	3.6 dB
Mesure des perturbations conduites en tension sur le réseau de télécommunication <i>Measurement of conducted disturbances in voltage on the telecommunication port.</i>	3.26 dB	A l'étude / Under consid.
Mesure des perturbations discontinues conduites en tension <i>Measurement of discontinuous conducted disturbances in voltage</i>	3.45 dB	3.6 dB
Mesure des perturbations conduites en courant <i>Measurement of conducted disturbances in current</i>	3.09 dB	A l'étude / Under consid.
Mesure du champ électrique rayonné sur le site en espace libre de Moirans <i>Measurement of radiated electric field on the Moirans open area test site</i>	5.20 dB	6.3 dB

Les valeurs d'incertitudes calculées du laboratoire étant inférieures aux valeurs d'incertitudes limites établies par la norme, la conformité de l'échantillon est établie directement par les niveaux limites applicables. / *The uncertainty values calculated by the laboratory are lower than limit uncertainty values defined by the standard. The conformity of the sample is directly established by the applicable limits values.*