

TEST REPORT

Test Report No.: 1-5566/17-01-02-A

BNetzA-CAB-02/21-102

Testing Laboratory

CTC advanced GmbH

Untertuerkheimer Strasse 6 – 10
66117 Saarbruecken/Germany
Phone: + 49 681 5 98 - 0
Fax: + 49 681 5 98 - 9075
Internet: <http://www.ctcadvanced.com>
e-mail: mail@ctcadvanced.com

Accredited Test Laboratory:

The testing laboratory (area of testing) is accredited according to DIN EN ISO/IEC 17025 (2005) by the Deutsche Akkreditierungsstelle GmbH (DAKKS). The accreditation is valid for the scope of testing procedures as stated in the accreditation certificate with the registration number: D-PL-12076-01-03

Applicant

Ingenico Group

9 Avenue de la Gare Rovaltain
26958 Valence Cedex 9/France

Contact: Jean-Baptiste Palisse
e-mail: jean-baptiste.palisse@ingenico.com
Phone: +33 4 75 84 21 74
Fax:

Manufacturer

Ingenico Group

9 Avenue de la Gare Rovaltain
26958 Valence Cedex 9/France

Test Standards

IEEE 1528-2013 Recommended Practice for Determining the Peak Spatial-Average Specific Absorption Rate (SAR) in the Human Head from Wireless Communications Devices: Measurement Techniques
RSS-102 Issue 5 Radio Frequency Exposure Compliance of Radiocommunication Apparatus (All Frequency Bands)

For further applied test standards please refer to section 3 of this test report.

Test Item

Kind of test item:	Payment terminal
Device type:	portable device
Model name:	Move/5000 CL/4G/Wifi/BT / Move/3500 CL/4G/Wifi/BT
S/N serial number:	180317303201083402304887 180317303201094402300908 / 180317303201083402304879
FCC-ID:	XKB-M5000CL4GWIBT
IC:	2586D-M50CL4GWIBT
Product Marketing Name (PMN):	Move/5000 & Move/3500
Hardware Version Identification No. (HVIN):	Move/5000 CL/4G/WiFi/BT / Move/3500 CL/4G/WiFi/BT
IMEI-Number:	004401082440534 / 004401082441342
Hardware status:	01
Software status:	OS VERSION : 040102 / APPLI VERSION : 009400
Frequency:	see technical details
Antenna:	integrated 4 antennas
Battery option:	P/N: F12432566 3.6V / 2900mAh
Module information:	Gemalto ELS81-US
Test sample status:	identical prototype
Exposure category:	general population / uncontrolled environment

This test report is electronically signed and valid without handwriting signature. For verification of the electronic signatures, the public keys can be requested at the testing laboratory.

Test Report authorised:

Alexander Hnatovskiy
Lab Manager
Radio Communications & EMC

Test performed:

Marco Scigliano
Testing Manager
Radio Communications & EMC

1	Table of contents	2
1	Table of contents.....	2
2	General information	4
2.1	Notes and disclaimer	4
2.2	Application details	4
2.3	Statement of compliance.....	4
2.4	Technical details	5
2.5	Transmitter and Antenna Operating Configurations	5
3	Test standards/ procedures references	6
3.1	RF exposure limits	7
4	Summary of Measurement Results	8
4.1	SAR measurement variability and measurement uncertainty analysis.....	8
5	Test Environment	8
6	Test Set-up.....	9
6.1	Measurement system.....	9
6.1.1	System Description.....	9
6.1.2	Test environment.....	10
6.1.3	Probe description.....	10
6.1.4	Phantom description.....	11
6.1.5	Device holder description	12
6.1.6	Scanning procedure	13
6.1.7	Spatial Peak SAR Evaluation	14
6.1.8	Data Storage and Evaluation.....	15
6.1.9	Tissue simulating liquids: dielectric properties	17
6.1.10	Tissue simulating liquids: parameters	18
6.1.11	Measurement uncertainty evaluation for SAR test.....	19
6.1.12	Measurement uncertainty evaluation for System Check.....	22
6.1.13	System check	23
6.1.14	System check procedure	24
6.1.15	System validation	25
7	Detailed Test Results	26
7.1	Conducted power measurements.....	26
7.1.1	Conducted power measurements WCDMA FDD V (850 MHz).....	26
7.1.2	Conducted power measurements WCDMA FDD IV (1700 MHz).....	27
7.1.3	Conducted power measurements WCDMA FDD II (1900 MHz).....	28
7.1.4	Test-set-up information for WCDMA / HSPDA / HSUPA	29
7.1.5	Conducted power measurements LTE FDD 2 1900 MHz.....	33
7.1.6	Conducted power measurements LTE FDD 4 1700 MHz.....	36
7.1.7	Conducted power measurements LTE FDD 5 850 MHz.....	39
7.1.8	Conducted power measurements LTE FDD 12 700 MHz.....	41
7.1.9	Justification of SAR measurements in LTE mode.....	43
7.1.10	MPR information in LTE mode	43
7.1.11	Conducted power measurements WLAN 2450 MHz	44
7.1.12	Conducted power measurements WLAN 5 GHz.....	45
7.1.1	Conducted average power measurements Bluetooth 2.4 GHz.....	46
7.1.2	Standalone SAR Test Exclusion according to FCC KDB 447498 D01	47
7.1.3	Standalone SAR Test Exclusion according to RSS-102 Issue 5	47
7.2	SAR test results.....	48
7.2.1	General description of test procedures	48
7.2.2	Results overview	49
7.2.3	Multiple Transmitter Information.....	57
8	Test equipment and ancillaries used for tests	59
9	Observations	59

Annex A:	System performance check	60
Annex B:	DASY5 measurement results	65
	Annex B.1: Liquid depth	74
Annex C:	Photo documentation	77
Annex D:	Calibration parameters	77
Annex E:	RSS-102 Annex A and B	77
Annex F:	Document History	78
Annex G:	Further Information	78

2 General information

2.1 Notes and disclaimer

The test results of this test report relate exclusively to the test item specified in this test report. CTC advanced GmbH does not assume responsibility for any conclusions and generalisations drawn from the test results with regard to other specimens or samples of the type of the equipment represented by the test item. The test report may only be reproduced or published in full. Reproduction or publication of extracts from the report requires the prior written approval of CTC advanced GmbH.

This test report is electronically signed and valid without handwriting signature. For verification of the electronic signatures, the public keys can be requested at the testing laboratory.

The testing service provided by CTC advanced GmbH has been rendered under the current "General Terms and Conditions for CTC advanced GmbH".

CTC advanced GmbH will not be liable for any loss or damage resulting from false, inaccurate, inappropriate or incomplete product information provided by the customer.

Under no circumstances does the CTC advanced GmbH test report include any endorsement or warranty regarding the functionality, quality or performance of any other product or service provided.

Under no circumstances does the CTC advanced GmbH test report include or imply any product or service warranties from CTC advanced GmbH, including, without limitation, any implied warranties of merchantability, fitness for purpose, or non-infringement, all of which are expressly disclaimed by CTC advanced GmbH.

All rights and remedies regarding vendor's products and services for which CTC advanced GmbH has prepared this test report shall be provided by the party offering such products or services and not by CTC advanced GmbH.

In no case this test report can be considered as a Letter of Approval.

2.2 Application details

Date of receipt of order:	2018-01-18
Date of receipt of test item:	2018-02-27
Start of test:	2018-03-01
End of test:	2018-03-15
Person(s) present during the test:	

2.3 Statement of compliance

The SAR values found for the Move/5000 CL/4G/Wifi/BT / Move/3500 CL/4G/Wifi/BT Payment terminal are below the maximum recommended levels of 4 W/Kg as averaged over any 10 g tissue according to the FCC rule §2.1093, the ANSI/IEEE C 95.1:1992, the NCRP Report Number 86 for uncontrolled environment, according to the Health Canada's Safety Code 6 and the Industry Canada Radio Standards Specification RSS-102 for General Population/Uncontrolled exposure.

2.4 Technical details

Band tested for this test report	Technology	Lowest transmit frequency/MHz	Highest transmit frequency/MHz	Lowest receive Frequency/MHz	Highest receive Frequency/MHz	Kind of modulation	Power Class	Tested power control level	Test channel low	Test channel middle	Test channel high	Maximum output power/dBm)*
<input checked="" type="checkbox"/>	UMTS FDD II	1852.4	1907.6	1932.4	1987.6	QPSK	3	max	9262	9400	9538	23.0
<input checked="" type="checkbox"/>	UMTS FDD IV	1712.4	1752.6	2112.4	2152.6	QPSK	3	max	1312	1412	1513	22.8
<input checked="" type="checkbox"/>	UMTS FDD V	826.4	846.6	871.4	891.6	QPSK	3	max	4132	4182	4233	23.4
<input checked="" type="checkbox"/>	LTE FDD 2	1850	1910	1930	1990	QPSK	3	max	18700	18900	19100	22.3
<input checked="" type="checkbox"/>	LTE FDD 4	1710	1755	2110	2155	QPSK	3	max	20050	20175	20300	22.9
<input checked="" type="checkbox"/>	LTE FDD 5	824	849	869	894	QPSK	3	max	20450	20525	20600	23.3
<input checked="" type="checkbox"/>	LTE FDD 12	704	711	734	741	QPSK	3	max	23060	23095	23130	23.4
<input checked="" type="checkbox"/>	WLAN	2412	2462	2412	2462	CCK OFDM	--	max	1	6	11	6.0
<input type="checkbox"/>	WLAN	5180	5240	5180	5240	OFDM	--	max	--	--	--	0.3
<input type="checkbox"/>	WLAN	5260	5320	5260	5320	OFDM	--	max	--	--	--	1.7
<input type="checkbox"/>	WLAN	5500	5700	5500	5700	OFDM	--	max	--	--	--	2.7
<input type="checkbox"/>	WLAN	5745	5825	5745	5825	OFDM	--	max	--	--	--	3.2
<input checked="" type="checkbox"/>	BT	2402	2480	2402	2480	GFSK	3	max	0	39	78	15.4

)*: measured averaged max. RMS power for UMTS, LTE, WLAN and BT.

LTE: Cat 4 / max. Data Rate DL / UL: 150 / 50 Mbps

2.5 Transmitter and Antenna Operating Configurations

Simultaneous transmission conditions
GSM / GPRS / EDGE / UMTS + BT + WLAN 2.4GHz
GSM / GPRS / EDGE / UMTS + BT + WLAN 5GHz

Table 1: Simultaneous transmission conditions

3 Test standards/ procedures references

Test Standard	Version	Test Standard Description
IEEE 1528-2013	2013-06	Recommended Practice for Determining the Peak Spatial-Average Specific Absorption Rate (SAR) in the Human Head from Wireless Communications Devices: Measurement Techniques
RSS-102 Issue 5	2015-03	Radio Frequency Exposure Compliance of Radiocommunication Apparatus (All Frequency Bands)
Canada's Safety Code No. 6	2015-06	Limits of Human Exposure to Radiofrequency Electromagnetic Fields in the Frequency Range from 3 kHz to 300 GHz
IEEE Std. C95-3	2002	IEEE Recommended Practice for the Measurement of Potentially Hazardous Electromagnetic Fields – RF and Microwave
IEEE Std. C95-1	2005	IEEE Standard for Safety Levels with Respect to Human Exposure to Radio Frequency Electromagnetic Fields, 3 kHz to 300 GHz.
IEC 62209-2	2010	Human exposure to radio frequency fields from hand-held and bodymounted wireless communication devices. Human models, instrumentation, and procedures. Procedure to determine the specific absorption rate (SAR) for wireless communication devices used in close proximity to the human body (frequency range of 30 MHz to 6 GHz)
FCC KDBs:		
KDB 865664D01v01	August 7, 2015	FCC OET SAR measurement requirements 100 MHz to 6 GHz
KDB 865664D02v01	October 23, 2015	RF Exposure Compliance Reporting and Documentation Considerations
KDB 447498D01v06	October 23, 2015	Mobile and Portable Devices RF Exposure Procedures and Equipment Authorization Policies
KDB 648474D04v01	October 23, 2015	SAR Evaluation Considerations for Wireless Handsets
KDB 941225D01v03	October 23, 2015	SAR Measurements Procedures for 3G Devices
KDB 941225D05v02	October 23, 2015	SAR for LTE Devices
KDB 941225D05Av01	October 23, 2015	LTE Rel. 10 KDB Inquiry Sheet
KDB 941225D06v02	October 23, 2015	SAR Evaluation Procedures for Portable Devices with Wireless Router Capabilities
KDB 248227D01v02	October 23, 2015	SAR Measurement Procedures for 802.11 a/b/g Transmitters

3.1 RF exposure limits

Human Exposure	Uncontrolled Environment General Population	Controlled Environment Occupational
Spatial Peak SAR* (Brain and Trunk)	1.60 mW/g	8.00 mW/g
Spatial Average SAR** (Whole Body)	0.08 mW/g	0.40 mW/g
Spatial Peak SAR*** (Hands/Feet/Ankle/Wrist)	4.00 mW/g	20.00 mW/g

Table 2: RF exposure limits

The limit applied in this test report is shown in bold letters

Notes:

* The Spatial Peak value of the SAR averaged over any 1 gram of tissue (defined as a tissue volume in the shape of a cube) and over the appropriate averaging time

** The Spatial Average value of the SAR averaged over the whole body.

*** The Spatial Peak value of the SAR averaged over any 10 grams of tissue (defined as a tissue volume in the shape of a cube) and over the appropriate averaging time.

Uncontrolled Environments are defined as locations where there is the exposure of individuals who have no knowledge or control of their exposure.

Controlled Environments are defined as locations where there is exposure that may be incurred by persons who are aware of the potential for exposure, (i.e. as a result of employment or occupation).

4 Summary of Measurement Results

<input checked="" type="checkbox"/>	No deviations from the technical specifications ascertained	
<input type="checkbox"/>	Deviations from the technical specifications ascertained	
Maximum SAR value (W/kg)		
	reported	limit
extremity 0 mm distance for 10g	2.813	4.0
collocated situations ΣSAR evaluation	3.063	4.0

4.1 SAR measurement variability and measurement uncertainty analysis

This analysis is required for worst case results larger than 2.0 W/kg for 10g.

frequency band	highest original measurement result at worst case position (W/kg)	repeated measurement result at worst case position (W/kg)	ratio <1.2
UMTS FDD II 1900	2.340	2.060	1.14
LTE FDD 2 1900	2.010	2.080	1.03
UMTS FDD VI 1750	2.360	2.480	1.05
LTE FDD 4 1750	2.260	2.220	1.02

5 Test Environment

Ambient temperature:	20 – 24 °C
Tissue Simulating liquid:	20 – 24 °C
Relative humidity content:	40 – 50 %
Air pressure:	not relevant for this kind of testing
Power supply:	230 V / 50 Hz

Exact temperature values for each test are shown in the table(s) under 7.1 and/or on the measurement plots.

6 Test Set-up

6.1 Measurement system

6.1.1 System Description

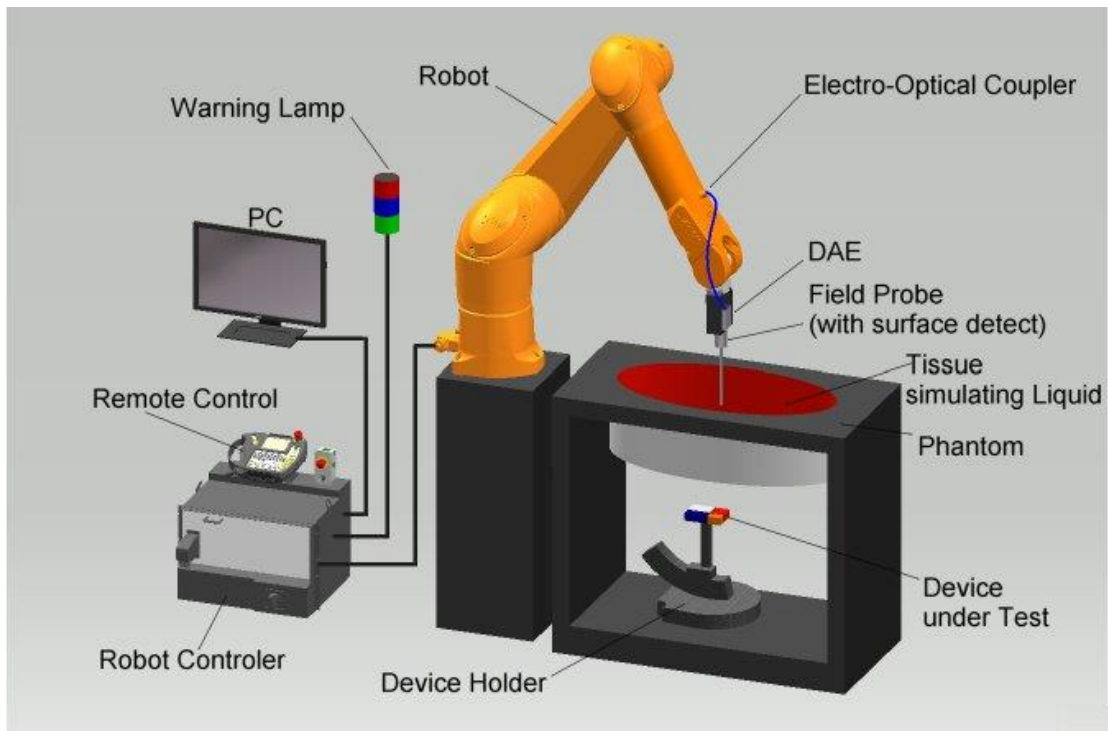

- The DASYS system for performing compliance tests consists of the following items:
- A standard high precision 6-axis robot (Stäubli RX/TX family) with controller and software. An arm extension for accommodating the data acquisition electronics (DAE).
- A dosimetric probe, i.e. an isotropic E-field probe optimized and calibrated for usage in tissue simulating liquid.
- A data acquisition electronic (DAE) which performs the signal amplification, signal multiplexing, AD-conversion, offset measurements, mechanical surface detection, collision detection, etc. The unit is battery powered with standard or rechargeable batteries. The signal is optically transmitted to the EOC.
- The Electro-Optical Coupler (EOC) performs the conversion from the optical into a digital electric signal of the DAE. The EOC is connected to the DASYS measurement server.
- The DASYS measurement server, which performs all real-time data evaluation for field measurements and surface detection, controls robot movements and handles safety operation. A computer operating Windows 7.
- DASYS software and SEMCAD data evaluation software.
- Remote control with teach panel and additional circuitry for robot safety such as warning lamps, etc.
- The generic twin phantom enabling the testing of left-hand and right-hand usage.
- The triple flat and eli phantom for the testing of handheld and body-mounted wireless devices.
- The device holder for handheld mobile phones and mounting device adaptor for laptops
- Tissue simulating liquid mixed according to the given recipes.
- System check dipoles allowing to validate the proper functioning of the system.

6.1.2 Test environment

The DASY measurement system is placed in a laboratory room within an environment which avoids influence on SAR measurements by ambient electromagnetic fields and any reflection from the environment. The pictures at the beginning of the photo documentation show a complete view of the test environment. The system allows the measurement of SAR values larger than 0.005 mW/g.

6.1.3 Probe description

Isotropic E-Field Probe ES3DV3 for Dosimetric Measurements	
Technical data according to manufacturer information	
Construction	Symmetrical design with triangular core Interleaved sensors Built-in shielding against static charges PEEK enclosure material (resistant to organic solvents, e.g., butyl diglycol)
Calibration	Calibration certificate in Appendix D
Frequency	10 MHz to 3 GHz (dosimetry); Linearity: ± 0.2 dB (30 MHz to 3 GHz)
Directivity	± 0.2 dB in HSL (rotation around probe axis) ± 0.3 dB in HSL (rotation normal to probe axis)
Dynamic range	5 μ W/g to > 100 mW/g; Linearity: ± 0.2 dB
Dimensions	Overall length: 330 mm Tip length: 20 mm Body diameter: 12 mm Tip diameter: 3.9 mm Distance from probe tip to dipole centers: 2.0 mm
Application	General dosimetry up to 3 GHz Compliance tests of mobile phones Fast automatic scanning in arbitrary phantoms (ES3DV3)
Isotropic E-Field Probe EX3DV4 for Dosimetric Measurements	
Technical data according to manufacturer information	
Construction	Symmetrical design with triangular core Interleaved sensors Built-in shielding against static charges PEEK enclosure material (resistant to organic solvents, e.g., DGBE)
Calibration	ISO/IEC 17025 calibration service available.
Frequency	10 MHz to >6 GHz (dosimetry); Linearity: ± 0.2 dB (30 MHz to 6 GHz)
Directivity	± 0.3 dB in HSL (rotation around probe axis) ± 0.5 dB in tissue material (rotation normal to probe axis)
Dynamic range	10 μ W/g to > 100 mW/g; Linearity: ± 0.2 dB (noise: typically <1 μ W/g)
Dimensions	Overall length: 337 mm (Tip: 20mm) Tip length: 2.5 mm (Body: 12mm) Typical distance from probe tip to dipole centers: 1mm
Application	High precision dosimetric measurements in any exposure scenario (e.g., very strong gradient fields). Only probe which enables compliance testing for frequencies up to 6 GHz with precision of better 30%.

6.1.4 Phantom description

The used SAM Phantom meets the requirements specified in FCC KDB865664 D01 for Specific Absorption Rate (SAR) measurements.

The phantom consists of a fibreglass shell integrated in a wooden table. It allows left-hand and right-hand head as well as body-worn measurements with a maximum liquid depth of 18 cm in head position and 22 cm in planar position (body measurements). The thickness of the Phantom shell is 2 mm +/- 0.1 mm.

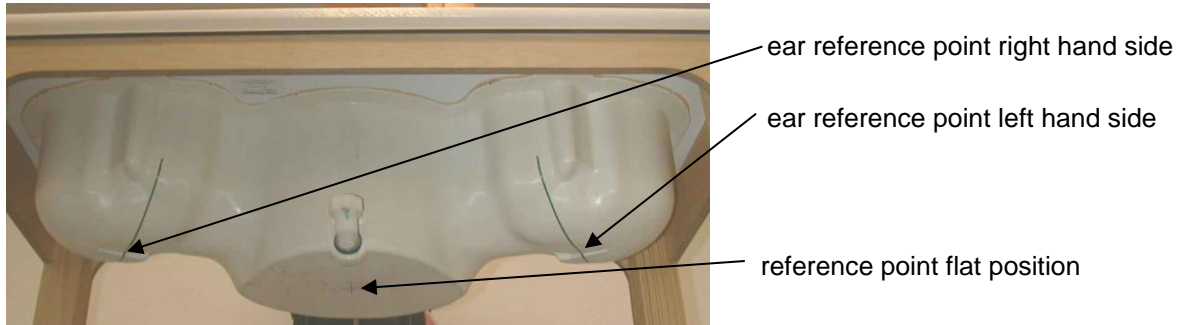

Triple Modular Phantom consists of three identical modules which can be installed and removed separately without emptying the liquid. It includes three reference points for phantom installation. Covers prevent evaporation of the liquid. Phantom material is resistant to DGBE based tissue simulating liquids.

6.1.5 Device holder description

The DASY device holder has two scales for device rotation (with respect to the body axis) and the device inclination (with respect to the line between the ear openings). The plane between the ear openings and the mouth tip has a rotation angle of 65°. The bottom plate contains three pair of bolts for locking the device holder. The device holder positions are adjusted to the standard measurement positions in the three sections. This device holder is used for standard mobile phones or PDA's only. If necessary an additional support of polystyrene material is used.



Larger DUT's (e.g. notebooks) cannot be tested using this device holder. Instead a support of bigger polystyrene cubes and thin polystyrene plates is used to position the DUT in all relevant positions to find and measure spots with maximum SAR values.

Therefore those devices are normally only tested at the flat part of the SAM.

6.1.6 Scanning procedure

- The DASY installation includes predefined files with recommended procedures for measurements and system check. They are read-only document files and destined as fully defined but unmeasured masks. All test positions (head or body-worn) are tested with the same configuration of test steps differing only in the grid definition for the different test positions.
- The „reference“ and „drift“ measurements are located at the beginning and end of the batch process. They measure the field drift at one single point in the liquid over the complete procedure. The indicated drift is mainly the variation of the DUT's output power and should vary max. +/- 5 %.
- The highest integrated SAR value is the main concern in compliance test applications. These values can mostly be found at the inner surface of the phantom and cannot be measured directly due to the sensor offset in the probe. To extrapolate the surface values, the measurement distances to the surface must be known accurately. A distance error of 0.5mm could produce SAR errors of 6% at 1800 MHz. Using predefined locations for measurements is not accurate enough. Any shift of the phantom (e.g., slight deformations after filling it with liquid) would produce high uncertainties. For an automatic and accurate detection of the phantom surface, the DASY5 system uses the mechanical surface detection. The detection is always at touch, but the probe will move backward from the surface the indicated distance before starting the measurement.
- The „area scan“ measures the SAR above the DUT or verification dipole on a parallel plane to the surface. It is used to locate the approximate location of the peak SAR with 2D spline interpolation. The robot performs a stepped movement along one grid axis while the local electrical field strength is measured by the probe. The probe is touching the surface of the SAM during acquisition of measurement values. The scan uses different grid spacings for different frequency measurements. Standard grid spacing for head measurements in frequency ranges ≤ 2 GHz is 15 mm in x- and y-dimension. For higher frequencies a finer resolution is needed, thus for the grid spacing is reduced according the following table:

Area scan grid spacing for different frequency ranges	
Frequency range	Grid spacing
≤ 2 GHz	≤ 15 mm
2 – 4 GHz	≤ 12 mm
4 – 6 GHz	≤ 10 mm

Grid spacing and orientation have no influence on the SAR result. For special applications where the standard scan method does not find the peak SAR within the grid, e.g. mobile phones with flip cover, the grid can be adapted in orientation. Results of this coarse scan are shown in annex B.

- A „zoom scan“ measures the field in a volume around the 2D peak SAR value acquired in the previous „coarse“ scan. It uses a fine meshed grid where the robot moves the probe in steps along all the 3 axis (x, y and z-axis) starting at the bottom of the Phantom. The grid spacing for the cube measurement is varied according to the measured frequency range, the dimensions are given in the following table:

Zoom scan grid spacing and volume for different frequency ranges			
Frequency range	Grid spacing for x, y axis	Grid spacing for z axis	Minimum zoom scan volume
≤ 2 GHz	≤ 8 mm	≤ 5 mm	≥ 30 mm
2 – 3 GHz	≤ 5 mm*	≤ 5 mm	≥ 28 mm
3 – 4 GHz	≤ 5 mm*	≤ 4 mm	≥ 28 mm
4 – 5 GHz	≤ 4 mm*	≤ 3 mm	≥ 25 mm
5 – 6 GHz	≤ 4 mm*	≤ 2 mm	≥ 22 mm

* When zoom scan is required and the reported SAR from the area scan based 1-g SAR estimation procedures of KDB Publication 447498 is ≤ 1.4 W/kg, ≤ 8 mm, ≤ 7 mm and ≤ 5 mm zoom scan resolution may be applied, respectively, for 2 GHz to 3 GHz, 3 GHz to 4 GHz and 4 GHz to 6 GHz.

DASY is also able to perform repeated zoom scans if more than 1 peak is found during area scan. In this document, the evaluated peak 1g and 10g averaged SAR values are shown in the 2D-graphics in annex B. Test results relevant for the specified standard (see section 3) are shown in table form in section 7.

6.1.7 Spatial Peak SAR Evaluation

The spatial peak SAR - value for 1 and 10 g is evaluated after the Cube measurements have been done. The basis of the evaluation are the SAR values measured at the points of the fine cube grid consisting of all points in the three directions x, y and z. The algorithm that finds the maximal averaged volume is separated into three different stages.

- The data between the dipole center of the probe and the surface of the phantom are extrapolated. This data cannot be measured since the center of the dipole is 1 to 2.7 mm away from the tip of the probe and the distance between the surface and the lowest measuring point is about 1 mm (see probe calibration sheet). The extrapolated data from a cube measurement can be visualized by selecting 'Graph Evaluated'.
- The maximum interpolated value is searched with a straight-forward algorithm. Around this maximum the SAR - values averaged over the spatial volumes (1g or 10 g) are computed using the 3d-spline interpolation algorithm. If the volume cannot be evaluated (i.e., if a part of the grid was cut off by the boundary of the measurement area) the evaluation will be started on the corners of the bottom plane of the cube.
- All neighbouring volumes are evaluated until no neighbouring volume with a higher average value is found.

Extrapolation

The extrapolation is based on a least square algorithm [W. Gander, Computermathematik, p.168-180]. Through the points in the first 3 cm along the z-axis, polynomials of order four are calculated. These polynomials are then used to evaluate the points between the surface and the probe tip. The points, calculated from the surface, have a distance of 1 mm from each other.

Interpolation

The interpolation of the points is done with a 3d-Spline. The 3d-Spline is composed of three one-dimensional splines with the "Not a knot"-condition [W. Gander, Computermathematik, p.141-150] (x, y and z -direction) [Numerical Recipes in C, Second Edition, p.123ff].

Volume Averaging

At First the size of the cube is calculated. Then the volume is integrated with the trapezoidal algorithm. 8000 points (20x20x20) are interpolated to calculate the average.

Advanced Extrapolation

DASY uses the advanced extrapolation option which is able to compensate boundary effects on E-field probes.

6.1.8 Data Storage and Evaluation

Data Storage

The DASY software stores the acquired data from the data acquisition electronics as raw data (in microvolt readings from the probe sensors), together with all necessary software parameters for the data evaluation (probe calibration data, liquid parameters and device frequency and modulation data) in measurement files with the extension ".DA4", ".DA5x". The software evaluates the desired unit and format for output each time the data is visualized or exported. This allows verification of the complete software setup even after the measurement and allows correction of incorrect parameter settings. For example, if a measurement has been performed with a wrong crest factor parameter in the device setup, the parameter can be corrected afterwards and the data can be re-evaluated.

The measured data can be visualized or exported in different units or formats, depending on the selected probe type ([V/m], [A/m], [°C], [mW/g], [mW/cm²], [dBrel], etc.). Some of these units are not available in certain situations or show meaningless results, e.g., a SAR output in a lossless media will always be zero. Raw data can also be exported to perform the evaluation with other software packages.

Data Evaluation by SEMCAD

The SEMCAD software automatically executes the following procedures to calculate the field units from the microvolt readings at the probe connector. The parameters used in the evaluation are stored in the configuration modules of the software:

Probe parameters:	- Sensitivity	Norm _i , a _{i0} , a _{i1} , a _{i2}
	- Conversion factor	ConvF _i
	- Diode compression point	Dcpi
Device parameters:	- Frequency	f
	- Crest factor	cf
Media parameters:	- Conductivity	σ
	- Density	ρ

These parameters must be set correctly in the software. They can be found in the component documents or they can be imported into the software from the configuration files issued for the DASY components. In the direct measuring mode of the multimeter option, the parameters of the actual system setup are used. In the scan visualization and export modes, the parameters stored in the corresponding document files are used.

The first step of the evaluation is a linearization of the filtered input signal to account for the compression characteristics of the detector diode. The compensation depends on the input signal, the diode type and the DC-transmission factor from the diode to the evaluation electronics.

If the exciting field is pulsed, the crest factor of the signal must be known to correctly compensate for peak power. The formula for each channel can be given as:

$$V_i = U_i + U_i^2 \cdot cf/dcp_i$$

with V_i = compensated signal of channel i (i = x, y, z)
 U_i = input signal of channel i (i = x, y, z)
 cf = crest factor of exciting field (DASY parameter)
 dcp_i = diode compression point (DASY parameter)

From the compensated input signals the primary field data for each channel can be evaluated:

E-field probes:
$$E_i = (V_i / Norm_i \cdot ConvF)^{1/2}$$

H-field probes:
$$H_i = (V_i)^{1/2} \cdot (a_{i0} + a_{i1}f + a_{i2}f^2)/f$$

with V_i = compensated signal of channel i (i = x, y, z)
 $Norm_i$ = sensor sensitivity of channel i (i = x, y, z)
[mV/(V/m)²] for E-field Probes
 $ConvF$ = sensitivity enhancement in solution
 a_{ij} = sensor sensitivity factors for H-field probes
 f = carrier frequency [GHz]
 E_i = electric field strength of channel i in V/m
 H_i = magnetic field strength of channel i in A/m

The RSS value of the field components gives the total field strength (Hermitian magnitude):

$$E_{tot} = (E_x^2 + E_y^2 + E_z^2)^{1/2}$$

The primary field data are used to calculate the derived field units.

$$SAR = (E_{tot}^2 \cdot \sigma) / (\rho \cdot 1000)$$

with SAR = local specific absorption rate in mW/g
 E_{tot} = total field strength in V/m
 σ = conductivity in [mho/m] or [Siemens/m]
 ρ = equivalent tissue density in g/cm³

Note that the density is normally set to 1 (or 1.06), to account for actual brain density rather than the density of the simulation liquid. The power flow density is calculated assuming the excitation field to be a free space field.

$$P_{pwe} = E_{tot}^2 / 3770 \quad \text{or} \quad P_{pwe} = H_{tot}^2 \cdot 37.7$$

with P_{pwe} = equivalent power density of a plane wave in mW/cm²
 E_{tot} = total electric field strength in V/m
 H_{tot} = total magnetic field strength in A/m

6.1.9 Tissue simulating liquids: dielectric properties

The following materials are used for producing the tissue-equivalent materials.

(Liquids used for tests described in section 7. are marked with ☒):

Ingredients (% of weight)	Frequency (MHz)								
	<input type="checkbox"/> 450	<input checked="" type="checkbox"/> 750	<input checked="" type="checkbox"/> 835	<input type="checkbox"/> 900	<input type="checkbox"/> 1450	<input checked="" type="checkbox"/> 1750	<input checked="" type="checkbox"/> 1900	<input checked="" type="checkbox"/> 2450	<input type="checkbox"/> 5000
frequency band									
Water	51.16	51.7	52.4	56.0	71.40	71.45	71.56	71.65	64 - 78
Salt (NaCl)	1.49	0.9	1.40	0.76	0.55	0.5	0.39	0.3	2 - 3
Sugar	46.78	47.2	45.0	41.76	0.0	0.0	0.0	0.0	0.0
HEC	0.52	0.0	1.0	1.21	0.0	0.0	0.0	0.0	0.0
Bactericide	0.05	0.1	0.1	0.27	0.1	0.1	0.1	0.1	0.0
Tween 20	0.0	0.0	0.0	0.0	27.95	27.95	27.95	27.95	0.0
Emulsifiers	0.0	0.0	0.0	0.0	0.0	0.0	0.0	0.0	9 - 15
Mineral Oil	0.0	0.0	0.0	0.0	0.0	0.0	0.0	0.0	11 - 18

Table 3: Body tissue dielectric properties

Salt: 99+% Pure Sodium Chloride

Water: De-ionized, 16MΩ+ resistivity

Sugar: 98+% Pure Sucrose

HEC: Hydroxyethyl Cellulose

Tween 20: Polyoxyethylene (20) sorbitan monolaurate

6.1.10 Tissue simulating liquids: parameters

Liquid MSL	Freq. (MHz)	Target body tissue		Measurement body tissue					Measurement date
		Permittivity	Conductivity (S/m)	Permittivity	Dev.	Conductivity		Dev.	
						ϵ''	(S/m)		
750	704	55.71	0.96	55.5	-0.3%	23.35	0.91	-4.7%	2018-03-02
	707	55.70	0.96	55.5	-0.3%	23.31	0.92	-4.5%	
	711	55.68	0.96	55.5	-0.3%	23.31	0.92	-4.0%	
	750	55.53	0.96	55.1	-0.8%	22.99	0.96	-0.4%	
850/900	826	55.24	0.97	55.1	-0.3%	21.32	0.98	1.1%	2018-03-15
	829	55.22	0.97	55.0	-0.4%	21.35	0.98	1.5%	
	835	55.20	0.97	54.9	-0.5%	21.34	0.99	2.2%	
	837	55.19	0.97	54.9	-0.5%	21.33	0.99	2.1%	
	844	55.17	0.98	54.8	-0.7%	21.30	1.00	1.9%	
	847	55.16	0.98	54.8	-0.7%	21.27	1.00	1.8%	
1750	1712	53.53	1.46	52.8	-1.3%	15.46	1.47	0.5%	2018-03-09
	1720	53.51	1.47	52.8	-1.3%	15.46	1.48	0.7%	
	1732	53.48	1.48	52.8	-1.3%	15.46	1.49	0.8%	
	1745	53.44	1.49	52.8	-1.3%	15.51	1.51	1.4%	
	1750	53.43	1.49	52.8	-1.3%	15.52	1.51	1.5%	
	1752	53.43	1.49	52.8	-1.3%	15.53	1.51	1.6%	
1900	1852	53.30	1.52	51.9	-2.6%	14.28	1.47	-3.2%	2018-03-13
	1860	53.30	1.52	51.9	-2.7%	14.26	1.48	-2.9%	
	1880	53.30	1.52	51.9	-2.7%	14.26	1.49	-1.9%	
	1900	53.30	1.52	51.7	-2.9%	14.36	1.52	-0.2%	
	1908	53.30	1.52	51.7	-3.1%	14.30	1.52	-0.2%	
2450	2402	52.76	1.90	50.9	-3.5%	14.51	1.94	1.8%	2018-03-14
	2412	52.75	1.91	50.9	-3.5%	14.54	1.95	1.9%	
	2437	52.72	1.94	50.7	-3.8%	14.55	1.97	1.8%	
	2441	52.71	1.94	50.7	-3.9%	14.55	1.98	1.8%	
	2450	52.70	1.95	50.7	-3.9%	14.58	1.99	1.9%	
	2462	52.68	1.97	50.6	-4.0%	14.65	2.01	2.0%	
	2480	52.66	1.99	50.5	-4.0%	14.70	2.03	1.8%	

Table 4: Parameter of the body tissue simulating liquid

Note: The dielectric properties have been measured using the contact probe method at 22°C.

6.1.11 Measurement uncertainty evaluation for SAR test

DASY5 Uncertainty Budget										
According to IEEE 1528/2003 and IEC 62209-1 for the 300 MHz - 3 GHz range										
Source of uncertainty	Uncertainty Value		Probability Distribution	Divisor	c _i (1g)	c _i (10g)	Standard Uncertainty		v _i ² or v _{eff}	
	± %						± %, (1g)	± %, (10g)		
Measurement System										
Probe calibration	± 6.0 %		Normal	1	1	1	± 6.0 %	± 6.0 %	∞	
Axial isotropy	± 4.7 %		Rectangular	√ 3	0.7	0.7	± 1.9 %	± 1.9 %	∞	
Hemispherical isotropy	± 9.6 %		Rectangular	√ 3	0.7	0.7	± 3.9 %	± 3.9 %	∞	
Boundary effects	± 1.0 %		Rectangular	√ 3	1	1	± 0.6 %	± 0.6 %	∞	
Probe linearity	± 4.7 %		Rectangular	√ 3	1	1	± 2.7 %	± 2.7 %	∞	
System detection limits	± 1.0 %		Rectangular	√ 3	1	1	± 0.6 %	± 0.6 %	∞	
Readout electronics	± 0.3 %		Normal	1	1	1	± 0.3 %	± 0.3 %	∞	
Response time	± 0.8 %		Rectangular	√ 3	1	1	± 0.5 %	± 0.5 %	∞	
Integration time	± 2.6 %		Rectangular	√ 3	1	1	± 1.5 %	± 1.5 %	∞	
RF ambient noise	± 3.0 %		Rectangular	√ 3	1	1	± 1.7 %	± 1.7 %	∞	
RF ambient reflections	± 3.0 %		Rectangular	√ 3	1	1	± 1.7 %	± 1.7 %	∞	
Probe positioner	± 0.4 %		Rectangular	√ 3	1	1	± 0.2 %	± 0.2 %	∞	
Probe positioning	± 2.9 %		Rectangular	√ 3	1	1	± 1.7 %	± 1.7 %	∞	
Max.SAR evaluation	± 1.0 %		Rectangular	√ 3	1	1	± 0.6 %	± 0.6 %	∞	
Test Sample Related										
Device positioning	± 2.9 %		Normal	1	1	1	± 2.9 %	± 2.9 %	145	
Device holder uncertainty	± 3.6 %		Normal	1	1	1	± 3.6 %	± 3.6 %	5	
Power drift	± 5.0 %		Rectangular	√ 3	1	1	± 2.9 %	± 2.9 %	∞	
Phantom and Set-up										
Phantom uncertainty	± 4.0 %		Rectangular	√ 3	1	1	± 2.3 %	± 2.3 %	∞	
Liquid conductivity (target)	± 5.0 %		Rectangular	√ 3	0.64	0.43	± 1.8 %	± 1.2 %	∞	
Liquid conductivity (meas.)	± 5.0 %		Rectangular	√ 3	0.64	0.43	± 1.8 %	± 1.2 %	∞	
Liquid permittivity (target)	± 5.0 %		Rectangular	√ 3	0.6	0.49	± 1.7 %	± 1.4 %	∞	
Liquid permittivity (meas.)	± 5.0 %		Rectangular	√ 3	0.6	0.49	± 1.7 %	± 1.4 %	∞	
Combined Std.							± 11.1 %	± 10.8 %	387	
Expanded Std.							± 22.1 %	± 21.6 %		

Table 5: Measurement uncertainties

Worst-Case uncertainty budget for DASY5 assessed according to IEEE 1528/2003.

The budget is valid for 2G and 3G communication signals and frequency range 300MHz - 3 GHz.

For these conditions it represents a worst-case analysis. For specific tests and configurations, the uncertainty could be considerable smaller.

Relative DASY5 Uncertainty Budget for SAR Tests								
According to IEEE 1528/2013 and IEC62209/2011 for the 0.3 - 3GHz range								
Error Description	Uncertainty Value ± %	Probability Distribution	Divisor	c _i (1g)	c _i (10g)	Standard Uncertainty		v _i ² or v _{eff}
						± %, (1g)	± %, (10g)	
Measurement System								
Probe calibration	± 6.0 %	Normal	1	1	1	± 6.0 %	± 6.0 %	∞
Axial isotropy	± 4.7 %	Rectangular	√ 3	0.7	0.7	± 1.9 %	± 1.9 %	∞
Hemispherical isotropy	± 9.6 %	Rectangular	√ 3	0.7	0.7	± 3.9 %	± 3.9 %	∞
Boundary effects	± 1.0 %	Rectangular	√ 3	1	1	± 0.6 %	± 0.6 %	∞
Probe linearity	± 4.7 %	Rectangular	√ 3	1	1	± 2.7 %	± 2.7 %	∞
System detection limits	± 1.0 %	Rectangular	√ 3	1	1	± 0.6 %	± 0.6 %	∞
Modulation Response	± 2.4 %	Rectangular	√ 3	1	1	± 1.4 %	± 1.4 %	∞
Readout electronics	± 0.3 %	Normal	1	1	1	± 0.3 %	± 0.3 %	∞
Response time	± 0.8 %	Rectangular	√ 3	1	1	± 0.5 %	± 0.5 %	∞
Integration time	± 2.6 %	Rectangular	√ 3	1	1	± 1.5 %	± 1.5 %	∞
RF ambient noise	± 3.0 %	Rectangular	√ 3	1	1	± 1.7 %	± 1.7 %	∞
RF ambient reflections	± 3.0 %	Rectangular	√ 3	1	1	± 1.7 %	± 1.7 %	∞
Probe positioner	± 0.4 %	Rectangular	√ 3	1	1	± 0.2 %	± 0.2 %	∞
Probe positioning	± 2.9 %	Rectangular	√ 3	1	1	± 1.7 %	± 1.7 %	∞
Max. SAR evaluation	± 2.0 %	Rectangular	√ 3	1	1	± 1.2 %	± 1.2 %	∞
Test Sample Related								
Device positioning	± 2.9 %	Normal	1	1	1	± 2.9 %	± 2.9 %	145
Device holder uncertainty	± 3.6 %	Normal	1	1	1	± 3.6 %	± 3.6 %	5
Power drift	± 5.0 %	Rectangular	√ 3	1	1	± 2.9 %	± 2.9 %	∞
Phantom and Set-up								
Phantom uncertainty	± 6.1 %	Rectangular	√ 3	1	1	± 3.5 %	± 3.5 %	∞
SAR correction	± 1.9 %	Rectangular	√ 3	1	0.84	± 1.1 %	± 0.9 %	∞
Liquid conductivity (meas.)	± 5.0 %	Rectangular	√ 3	0.78	0.71	± 2.3 %	± 2.0 %	∞
Liquid permittivity (meas.)	± 5.0 %	Rectangular	√ 3	0.26	0.26	± 0.8 %	± 0.8 %	∞
Temp. Unc. - Conductivity	± 3.4 %	Rectangular	√ 3	0.78	0.71	± 1.5 %	± 1.4 %	∞
Temp. Unc. - Permittivity	± 0.4 %	Rectangular	√ 3	0.23	0.26	± 0.1 %	± 0.1 %	∞
Combined Uncertainty						± 11.3 %	± 11.3 %	330
Expanded Std. Uncertainty						± 22.7 %	± 22.5 %	

Table 6: Measurement uncertainties

Worst-Case uncertainty budget for DASY5 assessed according to IEEE 1528/2013 and IEC 62209-1/2011 standards. The budget is valid for the frequency range 300MHz -3 GHz and represents a worst-case analysis. For specific tests and configurations, the uncertainty could be considerable smaller.

DASY5 Uncertainty Budget										
According to IEC 62209-2/2010 for the 300 MHz - 6 GHz range										
Source of uncertainty	Uncertainty Value		Probability Distribution	Divisor	c _i (1g)	c _i (10g)	Standard Uncertainty		v _i ² or v _{eff}	
							± %, (1g)	± %, (10g)		
Measurement System										
Probe calibration	± 6.6 %		Normal	1	1	1	± 6.6 %	± 6.6 %	∞	
Axial isotropy	± 4.7 %		Rectangular	√ 3	0.7	0.7	± 1.9 %	± 1.9 %	∞	
Hemispherical isotropy	± 9.6 %		Rectangular	√ 3	0.7	0.7	± 3.9 %	± 3.9 %	∞	
Boundary effects	± 2.0 %		Rectangular	√ 3	1	1	± 1.2 %	± 1.2 %	∞	
Probe linearity	± 4.7 %		Rectangular	√ 3	1	1	± 2.7 %	± 2.7 %	∞	
System detection limits	± 1.0 %		Rectangular	√ 3	1	1	± 0.6 %	± 0.6 %	∞	
Modulation Response	± 2.4 %		Rectangular	√ 3	1	1	± 1.4 %	± 1.4 %	∞	
Readout electronics	± 0.3 %		Normal	1	1	1	± 0.3 %	± 0.3 %	∞	
Response time	± 0.8 %		Rectangular	√ 3	1	1	± 0.5 %	± 0.5 %	∞	
Integration time	± 2.6 %		Rectangular	√ 3	1	1	± 1.5 %	± 1.5 %	∞	
RF ambient noise	± 3.0 %		Rectangular	√ 3	1	1	± 1.7 %	± 1.7 %	∞	
RF ambient reflections	± 3.0 %		Rectangular	√ 3	1	1	± 1.7 %	± 1.7 %	∞	
Probe positioner	± 0.8 %		Rectangular	√ 3	1	1	± 0.5 %	± 0.5 %	∞	
Probe positioning	± 6.7 %		Rectangular	√ 3	1	1	± 3.9 %	± 3.9 %	∞	
Post-processing	± 4.0 %		Rectangular	√ 3	1	1	± 2.3 %	± 2.3 %	∞	
Test Sample Related										
Device positioning	± 2.9 %		Normal	1	1	1	± 2.9 %	± 2.9 %	145	
Device holder uncertainty	± 3.6 %		Normal	1	1	1	± 3.6 %	± 3.6 %	5	
Power drift	± 5.0 %		Rectangular	√ 3	1	1	± 2.9 %	± 2.9 %	∞	
Phantom and Set-up										
Phantom uncertainty	± 7.9 %		Rectangular	√ 3	1	1	± 4.6 %	± 4.6 %	∞	
SAR correction	± 1.9 %		Rectangular	√ 3	1	0.84	± 1.1 %	± 0.9 %	∞	
Liquid conductivity (meas.)	± 5.0 %		Rectangular	√ 3	0.78	0.71	± 2.3 %	± 2.0 %	∞	
Liquid permittivity (meas.)	± 5.0 %		Rectangular	√ 3	0.26	0.26	± 0.8 %	± 0.8 %	∞	
Temp. Unc. - Conductivity	± 3.4 %		Rectangular	√ 3	0.78	0.71	± 1.5 %	± 1.4 %	∞	
Temp. Unc. - Permittivity	± 0.4 %		Rectangular	√ 3	0.23	0.26	± 0.1 %	± 0.1 %	∞	
Combined Uncertainty							± 12.7 %	± 12.6 %	330	
Expanded Std. Uncertainty							± 25.4 %	± 25.3 %		

Table 7: Measurement uncertainties.

Worst-Case uncertainty budget for DASY5 assessed according to according to IEC 62209-2/2010 standard. The budget is valid for the frequency range 300MHz - 6 GHz and represents a worst-case analysis. For specific tests and configurations, the uncertainty could be considerable smaller.

6.1.12 Measurement uncertainty evaluation for System Check

Uncertainty of a System Performance Check with DASY5 System for the 0.3 - 3 GHz range								
Source of uncertainty	Uncertainty Value	Probability Distribution	Divisor	c_i	c_i	Standard Uncertainty		v_i^2 or
				(1g)	(10g)	± %, (1g)	± %, (10g)	v_{eff}
Measurement System								
Probe calibration	± 6.0 %	Normal	1	1	1	± 6.0 %	± 6.0 %	∞
Axial isotropy	± 4.7 %	Rectangular	√ 3	0.7	0.7	± 1.9 %	± 1.9 %	∞
Hemispherical isotropy	± 0.0 %	Rectangular	√ 3	0.7	0.7	± 0.0 %	± 0.0 %	∞
Boundary effects	± 1.0 %	Rectangular	√ 3	1	1	± 0.6 %	± 0.6 %	∞
Probe linearity	± 4.7 %	Rectangular	√ 3	1	1	± 2.7 %	± 2.7 %	∞
System detection limits	± 1.0 %	Rectangular	√ 3	1	1	± 0.6 %	± 0.6 %	∞
Readout electronics	± 0.3 %	Normal	1	1	1	± 0.3 %	± 0.3 %	∞
Response time	± 0.0 %	Rectangular	√ 3	1	1	± 0.0 %	± 0.0 %	∞
Integration time	± 0.0 %	Rectangular	√ 3	1	1	± 0.0 %	± 0.0 %	∞
RF ambient conditions	± 3.0 %	Rectangular	√ 3	1	1	± 1.7 %	± 1.7 %	∞
Probe positioner	± 0.4 %	Rectangular	√ 3	1	1	± 0.2 %	± 0.2 %	∞
Probe positioning	± 2.9 %	Rectangular	√ 3	1	1	± 1.7 %	± 1.7 %	∞
Max. SAR evaluation	± 1.0 %	Rectangular	√ 3	1	1	± 0.6 %	± 0.6 %	∞
Test Sample Related								
Dev. of experimental dipole	± 0.0 %	Rectangular	√ 3	1	1	± 0.0 %	± 0.0 %	∞
Source to liquid distance	± 2.0 %	Rectangular	√ 3	1	1	± 1.2 %	± 1.2 %	∞
Power drift	± 3.4 %	Rectangular	√ 3	1	1	± 2.0 %	± 2.0 %	∞
Phantom and Set-up								
Phantom uncertainty	± 4.0 %	Rectangular	√ 3	1	1	± 2.3 %	± 2.3 %	∞
SAR correction	± 1.9 %	Rectangular	√ 3	1	0.84	± 1.1 %	± 0.9 %	∞
Liquid conductivity (meas.)	± 5.0 %	Normal	1	0.78	0.71	± 3.9 %	± 3.6 %	∞
Liquid permittivity (meas.)	± 5.0 %	Normal	1	0.26	0.26	± 1.3 %	± 1.3 %	∞
Temp. unc. - Conductivity	± 1.7 %	Rectangular	√ 3	0.78	0.71	± 0.8 %	± 0.7 %	∞
Temp. unc. - Permittivity	± 0.3 %	Rectangular	√ 3	0.23	0.26	± 0.0 %	± 0.0 %	∞
Combined Uncertainty						± 9.1 %	± 8.9 %	330
Expanded Std. Uncertainty						± 18.2 %	± 17.9 %	

Table 8: Measurement uncertainties of the System Check with DASY5 (0.3-3GHz)

Note: Worst case probe calibration uncertainty has been applied for all probes used during the measurements.

6.1.13 System check

The system check is performed for verifying the accuracy of the complete measurement system and performance of the software. The system check is performed with tissue equivalent material according to IEEE 1528. The following table shows system check results for all frequency bands and tissue liquids used during the tests (plot(s) see annex A).

System performance check (1000 mW)									
System validation Kit	Probe	Frequency	Target SAR _{1g} /mW/g (+/- 10%)	Target SAR _{10g} /mW/g (+/- 10%)	Measured SAR _{1g} / mW/g	SAR _{1g} dev.	Measured SAR _{10g} / mW/g	SAR _{10g} dev.	Measured date
D750V3 S/N: 1041	ES3DV3 S/N: 3320	750 MHz MSL	8.75	5.74	8.32	-4.9%	5.56	-3.1%	2018-03-02
D835V2 S/N: 4d153	ES3DV3 S/N: 3320	835 MHz MSL	9.53	6.28	10.30	8.1%	6.82	8.6%	2018-03-15
D1750V2 S/N: 1093	ES3DV3 S/N: 3320	1750 MHz MSL	37.50	20.30	37.20	-0.8%	19.60	-3.4%	2018-03-09
D1900V2 S/N: 5d009	ES3DV3 S/N: 3320	1900 MHz MSL	40.70	21.50	38.60	-5.2%	20.50	-4.7%	2018-03-13
D2450V2 S/N: 710	EX3DV4 S/N: 3944	2450 MHz MSL	51.10	24.20	50.30	-1.6%	23.40	-3.3%	2018-03-14

Table 9: Results system check

6.1.14 System check procedure

The system check is performed by using a validation dipole which is positioned parallel to the planar part of the SAM phantom at the reference point. The distance of the dipole to the SAM phantom is determined by a plexiglass spacer. The dipole is connected to the signal source consisting of signal generator and amplifier via a directional coupler, N-connector cable and adaption to SMA. It is fed with a power of 100 mW. To adjust this power a power meter is used. The power sensor is connected to the cable before the system check to measure the power at this point and do adjustments at the signal generator. At the outputs of the directional coupler both return loss as well as forward power are controlled during the validation to make sure that emitted power at the dipole is kept constant. This can also be checked by the power drift measurement after the test (result on plot).

System check results have to be equal or near the values determined during dipole calibration (target SAR in table above) with the relevant liquids and test system.

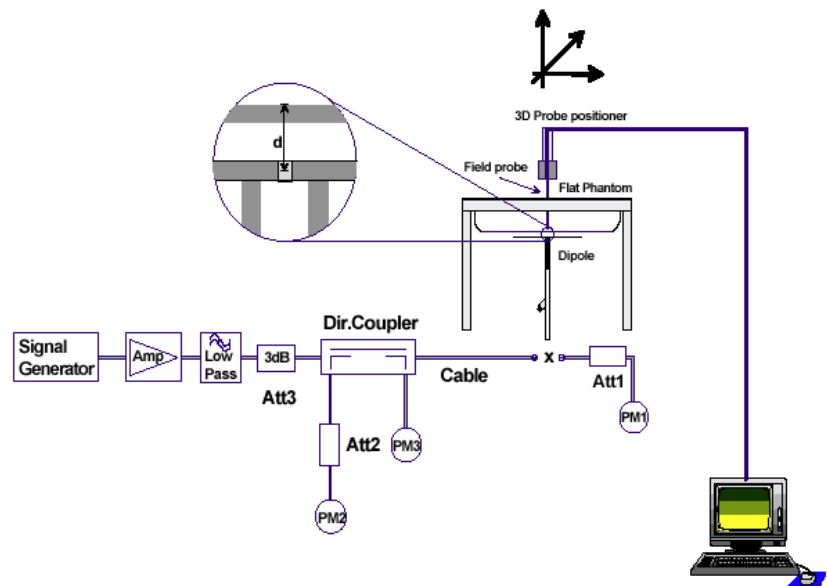

6.1.15 System validation

The system validation is performed in a similar way as a system check. It needs to be performed once a SAR measurement system has been established and allows an evaluation of the system accuracy with all components used together with the specified system. It has to be repeated at least once a year or when new system components are used (DAE, probe, phantom, dipole, liquid type).

In addition to the procedure used during system check a system validation also includes checks of probe isotropy, probe modulation factor and RF signal.

The following table lists the system validations relevant for this test report:

Frequency (MHz)	DASY SW	Dipole Type /SN	Probe Type / SN	Calibrated signal type(s)	DAE unit Type / SN	body validation
750	V52.8.7	D750V2 / 1041	ES3DV3 / 3320	CW	DAE3 / 413	2018-03-02
835	V52.8.7	D835V2 / 4d153	ES3DV3 / 3320	CW	DAE3 / 413	2018-03-06
1750	V52.8.7	D1750V2 / 1093	ES3DV3 / 3320	CW	DAE3 / 413	2018-03-08
1900	V52.8.7	D1900V2 / 5d009	ES3DV3 / 3320	CW	DAE3 / 413	2018-03-12
2450	V52.8.7	D2450V2 / 710	EX3DV4 / 3944	CW	DAE3/ 477	2017-06-20

7 Detailed Test Results

7.1 Conducted power measurements

For the measurements the Rohde & Schwarz Radio Communication Tester CMU 200 and CMW500 were used.

The output power was measured using an integrated RF connector and attached RF cable.

The conducted output power was also checked before and after each SAR measurement. The resulting power values were within a 0.2 dB tolerance of the values shown below.

7.1.1 Conducted power measurements WCDMA FDD V (850 MHz)

Max. RMS output power 850 MHz (FDD V) / dBm			
mode	CH 4132 / 826.4 MHz	CH 4182 / 836.6 MHz	CH 4233 / 846.6 MHz
RMC 12.2 kbit/s	23.3	23.4	23.4
RMC 64 kbit/s	23.2	23.3	23.4
RMC 144 kbit/s	23.1	23.3	23.3
RMC 384 kbit/s	23.2	23.2	23.3
AMR 4.75 kbit/s	23.2	23.3	23.3
AMR 5.15 kbit/s	23.1	23.2	23.2
AMR 5.9 kbit/s	23.2	23.4	23.3
AMR 6.7 kbit/s	23.2	23.3	23.3
AMR 7.4 kbit/s	23.1	23.4	23.2
AMR 7.95 kbit/s	23.2	23.4	23.2
AMR 10.2 kbit/s	23.2	23.3	23.3
AMR 12.2 kbit/s	23.2	23.2	23.4
HSDPA Sub test 1	23.2	23.2	23.2
HSDPA Sub test 2	22.0	22.1	22.2
HSDPA Sub test 3	21.5	21.6	21.8
HSDPA Sub test 4	21.6	21.8	21.6
HSUPA Sub test 1	23.3	23.2	23.3
HSUPA Sub test 2	21.1	21.1	21.2
HSUPA Sub test 3	22.2	22.2	22.3
HSUPA Sub test 4	21.2	21.1	21.1
HSUPA Sub test 5	23.1	23.3	23.2

Table 10: Test results conducted power measurement UMTS FDD V 850MHz

7.1.2 Conducted power measurements WCDMA FDD IV (1700 MHz)

Max. RMS output power FDD IV (1700MHz) / dBm			
mode	CH 1312 / 1712.4 MHz	CH 1412 / 1732.4 MHz	CH 1513 / 1752.6 MHz
RMC 12.2 kbit/s	22.8	22.8	22.7
RMC 64 kbit/s	22.6	22.7	22.7
RMC 144 kbit/s	22.7	22.6	22.6
RMC 384 kbit/s	22.6	22.6	22.6
AMR 4.75 kbit/s	22.6	22.8	22.6
AMR 5.15 kbit/s	22.7	22.6	22.6
AMR 5.9 kbit/s	22.6	22.7	22.6
AMR 6.7 kbit/s	22.6	22.7	22.5
AMR 7.4 kbit/s	22.7	22.7	22.6
AMR 7.95 kbit/s	22.6	22.7	22.6
AMR 10.2 kbit/s	22.6	22.7	22.6
AMR 12.2 kbit/s	22.7	22.7	22.5
HSDPA Sub test 1	22.7	22.6	22.5
HSDPA Sub test 2	21.5	21.6	21.5
HSDPA Sub test 3	21.1	21.0	21.0
HSDPA Sub test 4	21.1	21.2	20.9
HSUPA Sub test 1	22.6	22.6	22.5
HSUPA Sub test 2	20.6	20.7	20.5
HSUPA Sub test 3	21.7	21.7	21.6
HSUPA Sub test 4	20.6	20.6	20.5
HSUPA Sub test 5	22.8	22.8	22.6

Table 11: Test results conducted power measurement UMTS FDD IV 1700MHz

7.1.3 Conducted power measurements WCDMA FDD II (1900 MHz)

Max. RMS output power 1900 MHz (FDD II) / dBm			
mode	Channel / frequency		
	9262 / 1852.4 MHz	9400 / 1880.0 MHz	9538 / 1907.6 MHz
RMC 12.2 kbit/s	22.7	22.7	23.0
RMC 64 kbit/s	22.5	22.6	22.8
RMC 144 kbit/s	22.6	22.5	22.9
RMC 384 kbit/s	22.5	22.6	22.9
AMR 4.75 kbit/s	22.6	22.6	22.8
AMR 5.15 kbit/s	22.6	22.5	22.8
AMR 5.9 kbit/s	22.6	22.5	22.9
AMR 6.7 kbit/s	22.5	22.5	22.9
AMR 7.4 kbit/s	22.6	22.5	22.9
AMR 7.95 kbit/s	22.6	22.5	22.9
AMR 10.2 kbit/s	22.6	22.6	22.8
AMR 12.2 kbit/s	22.6	22.6	22.9
HSDPA Sub test 1	22.6	22.5	23.0
HSDPA Sub test 2	21.4	21.6	21.7
HSDPA Sub test 3	21.0	21.0	21.4
HSDPA Sub test 4	21.0	21.0	21.2
HSUPA Sub test 1	22.6	22.5	22.9
HSUPA Sub test 2	20.5	20.5	20.9
HSUPA Sub test 3	21.4	21.6	21.9
HSUPA Sub test 4	20.4	20.5	20.8
HSUPA Sub test 5	22.6	22.5	22.8

Table 12: Test results conducted power measurement UMTS FDD II 1900MHz

Remark: None of the HSDPA/HSUPA settings leads to conducted power values exceeding the conducted power in RMC mode by more than 0.25 dB.

Therefore no additional SAR measurements were performed in HSDPA/HSUPA mode.

7.1.4 Test-set-up information for WCDMA / HSPDA / HSUPA

a) WCDMA RMC

In RMC (reference measurement channel) mode the conducted power at 4 different bit rates was measured. They correspond with the used spreading factors as follows:

Bit rate	12.2 kbit/s	64 kbit/s	144 kbit/s	384 kbit/s
Spreading factor (SF)	64	16	8	4

In RMC mode only DPCCH and DPDCH are active. As bit rate changes do not influence the relative power of any code channel the measured RMS output power remains on the same level which is set to maximum by TPC (Transmit power control) pattern type 'All 1'.

b) HSDPA

HSDPA adds the HS-DPCCH in uplink as a control channel for high speed data transfer in downlink. In HSDPA mode 4 sub-tests are defined by 3GPP 34.121 according to the following table:

Sub-test	β_c	β_d	β_d (SF)	β_c/β_d	$\beta_{hs}^{(1)}$	CM(dB) ⁽²⁾
1	2/15	15/15	64	2/15	4/15	0.0
2	12/15 ⁽³⁾	15/15 ⁽³⁾	64	12/15 ⁽³⁾	24/15	1.0
3	15/15	8/15	64	15/8	30/15	1.5
4	15/15	4/15	64	15/4	30/15	1.5

Note 1: $\Delta_{ACK}, \Delta_{NACK}, \Delta_{CQI} = 8 \iff A_{hs} = \beta_{hs}/\beta_c = 30/15 \iff \beta_{hs} = 30/15 * \beta_c$

Note 2 : CM = 1 for $\beta_c/\beta_d = 12/15, \beta_{hs}/\beta_c = 24/15$

Note 3 : For subtest 2 the β_c/β_d ratio of 12/15 for the TFC during the measurement period (TF1, TF0) is achieved by setting the signalled gain factors for the reference TFC (TF1,TF1) to $\beta_c = 11/15$ and $\beta_d = 15/15$

Table 13: Sub-tests for UMTS Release 5 HSDPA

The β_c and β_d gain factors for DPCCH and DPDCH were set according to the values in the above table, β_{hs} for HS-DPCCH is set automatically to the correct value when $\Delta_{ACK}, \Delta_{NACK}, \Delta_{CQI} = 8$. The variation of the β_c/β_d ratio causes a power reduction at sub-tests 2 - 4.

The measurements were performed with a Fixed Reference Channel (FRC) and H-Set 1 QPSK.

Parameter	Value
Nominal average inf. bit rate	534 kbit/s
Inter-TTI Distance	3 TTI's
Number of HARQ Processes	2 Processes
Information Bit Payload	3202 Bits
MAC-d PDU size	336 Bits
Number Code Blocks	1 Block
Binary Channel Bits Per TTI	4800 Bits
Total Available SMLs in UE	19200 SMLs
Number of SMLs per HARQ Process	9600 SMLs
Coding Rate	0.67
Number of Physical Channel Codes	5

Table 14: settings of required H-Set 1 QPSK acc. to 3GPP 34.121

c) HSUPA

In HSUPA mode additional code channels (E-DPCCH, E-DPDCHn) are added for data transfer in uplink at higher bit rates.

5 sub-tests are defined by 3GPP 34.121 according to the following table:

Sub-test	β_c	β_d	β_d (SF)	β_c/β_d	$\beta_{hs}^{(1)}$	β_{ec}	β_{ed}	β_{ec} (SF)	β_{ed} (code)	CM ⁽²⁾ (dB)	MPR (dB)	AG ⁽⁴⁾ Index	E-TFCI
1	11/15 ⁽³⁾	15/15 ⁽³⁾	64	11/15 ⁽³⁾	22/15	209/225	1039/225	4	1	1.0	0.0	20	75
2	6/15	15/15	64	6/15	12/15	12/15	94/75	4	1	3.0	2.0	12	67
3	15/15	9/15	64	15/9	30/15	30/15	$\beta_{ed1}:47/15$ $\beta_{ed2}:47/15$	4	2	2.0	1.0	15	92
4	2/15	15/15	64	2/15	4/15	2/15	56/75	4	1	3.0	2.0	17	71
5	15/15 ⁽⁴⁾	15/15 ⁽⁴⁾	64	15/15 ⁽⁴⁾	30/15	24/15	134/15	4	1	1.0	0.0	21	81

Note 1 : $\Delta_{ACK}, \Delta_{NACK}, \Delta_{CQI} = 8 \iff A_{hs} = \beta_{hs}/\beta_c = 30/15 \iff \beta_{hs} = 30/15 * \beta_c$
 Note 2 : CM = 1 for $\beta_c/\beta_d = 12/15, \beta_{hs}/\beta_c = 24/15$. For all other combinations of DPDCH, DPCCH, HS-DPCCH, E-DPDCH and E-DPCCH the MPR is based on the relative CM difference
 Note 3 : For subtest 1 the β_c/β_d ratio of 11/15 for the TFC during the measurement period (TF1, TF0) is achieved by setting the signalled gain factors for the reference TFC (TF1,TF1) to $\beta_c = 10/15$ and $\beta_d = 15/15$
 Note 4 : For subtest 5 the β_c/β_d ratio of 15/15 for the TFC during the measurement period (TF1, TF0) is achieved by setting the signalled gain factors for the reference TFC (TF1,TF1) to $\beta_c = 14/15$ and $\beta_d = 15/15$
 Note 5 : Testing UE using E-DPDCH Physical Layer category 1 Sub-test 3 is not required according to TS 25.306 Table 5.1g
 Note 6 : β_{ed} can not be set directly; it is set by Absolute Grant Value

Table 15: Subtests for UMTS Release 6 HSUPA

To achieve the settings above some additional procedures were defined by 3GPP 34.121. Those have been included in an application note for the CMU200 and were exactly followed:

- Test mode connection (BS signal tab):
RMC 12.2 kbit/s + HSPA 34.108 with loop mode 1
- HS-DSCH settings (BS signal tab):
- FRC with H-set 1 QPSK
- ACK-NACK repetition factor = 3
- CQI feedback cycle = 4ms
- CQI repetition factor = 2
- HSUPA-specific signalling settings (UE signal tab):
- E-TFCI table index = 0
- E-DCH minimum set E-TFCI = 9
- Puncturing limit non-max = 0.84
- max. number of channelisation codes = 2x SF4
- Initial Serving Grant Value = Off
- HSDPA and HSUPA Gain factors (UE signal tab)

Sub-test	β_c	β_d	$\Delta_{ACK}, \Delta_{NACK}, \Delta_{CQI}$	$\Delta E-DPCCH$)*
1	10	15	8	6
2	6	15	8	8
3	15	9	8	8
4	2	15	8	5
5	14	15	8	7

)* : β_{ec} and β_{ed} ratios (relative to β_c and β_d) are set by $\Delta E-DPCCH$

- HSUPA Reference E-TFCIs (UE signal tab > HSUPA gain factors):

Sub-test	1, 2, 4, 5				
Number of E-TFCIs	5				
Reference E-TFCI	11	67	71	75	81
Reference E-TFCI power offset	4	18	23	26	27

Sub-test	3	
Number of E-TFCIs	2	
Reference E-TFCI	11	92
Reference E-TFCI power offset	4	18

- HSUPA-specific generator parameters (BS Signal tab > HSUPA > E-AGCH > AG Pattern)

Sub-test	Absolute Grant Value (AG Index)
1	20
2	12
3	15
4	17
5	21

- Power Level settings (BS Signal tab > Node B-settings):

- Level reference: Output Channel Power (Ior)

- Output Channel Power (Ior): -86 dBm

- Downlink Physical Channel Settings (BS signal tab)

- P-CPICH: -10 dB

- S-CPICH: Off

- P-SCH: -15 dB

- S-SCH : -15 dB

- P-CCPCH: -12 dB

- S-CCPCH: -12 dB

- PICH : -15 dB

- AICH : -12 dB

- DPDCH : -10 dB

- HS-SCCH : -8 dB

- HS-PDSCH : -3 dB

- E-AGCH : -20 dB

- E-RGCH/E-HICH - 20 dB

- E-RGCH Active: Off

The settings above were stored once for each sub-test and recalled before the measurement.

HSUPA test procedure:

To reach maximum output power in HSUPA mode the following procedures were followed:

3 different TPC patterns were defined:

Set 1 : Closed loop with target power 10 dBm

Set 2 : Single Pattern+Alternating with binary pattern '11111' for 1 dB steps 'up'

Set 3 : Single Pattern+Alternating with binary pattern '00000' for 1 dB steps 'down'

After recalling a certain HSUPA sub-test the HSUPA E-AGCH graph with E-TFCI event counter is displayed. After starting with the closed loop command the power is increased in 1 dB steps by activating pattern set 2 until the UE decreases the transmitted E-TFCI.

At this point set 3 is activated once to reduce the output power to the value at which the original E-TFCI, which is required for the sub-test, appears again.

For conducted power measurements the same steps are repeated in the power menu to read out the corresponding maximum RMS output power with the target E-TFCI.

For SAR measurements it is useful to switch to Code Domain Power vs. Time display.

Here the CMU200 shows relative power values (max. and min.) of each code channel which should roughly correspond to the numerators of the gain factors e.g.:

Sub-test	β_c	β_d	β_{hs}	β_{ec}	β_{ed}
5	15	15	30	24	134

By this way a surveillance of signalling conditions is possible to make sure that HSUPA code channels are active during the complete SAR measurement.

7.1.5 Conducted power measurements LTE FDD 2 1900 MHz

Bandwidth (MHz)	Channel / Frequency (MHz)	Resource block allocation	P _{avg} (dBm)	
			QPSK	16-QAM
1.4	18607 / 1850.7	1 RB low	22.2	21.2
		1 RB mid	22.1	21.2
		1 RB high	22.1	21.2
		50% RB low	22.1	21.1
		50% RB mid	22.1	21.1
		50% RB high	22.0	21.1
		100% RB	21.0	20.3
	18900 / 1880.0	1 RB low	22.1	21.5
		1 RB mid	22.1	21.5
		1 RB high	22.0	21.5
		50% RB low	22.1	21.2
		50% RB mid	22.1	21.1
		50% RB high	22.1	21.1
	19193 / 1909.3	1 RB low	22.0	20.9
		1 RB mid	21.9	20.8
		1 RB high	22.0	20.9
		50% RB low	22.0	21.1
		50% RB mid	21.9	21.1
50% RB high		21.9	21.0	
3.0	18615 / 1851.5	1 RB low	22.0	21.5
		1 RB mid	21.9	21.4
		1 RB high	21.8	21.3
		50% RB low	21.0	20.0
		50% RB mid	20.9	19.9
		50% RB high	20.9	19.9
		100% RB	20.9	20.1
	18900 / 1880.0	1 RB low	22.1	21.1
		1 RB mid	22.0	20.9
		1 RB high	22.0	21.0
		50% RB low	21.0	20.4
		50% RB mid	21.0	20.3
		50% RB high	21.0	20.3
	19185 / 1908.5	100% RB	20.9	20.0
		1 RB low	21.9	20.8
		1 RB mid	21.7	20.8
		1 RB high	21.8	20.7
		50% RB low	21.0	20.1
50% RB mid		20.9	20.0	
50% RB high		20.9	20.0	

Bandwidth (MHz)	Channel / Frequency (MHz)	Resource block allocation	P _{avg} (dBm)	
			QPSK	16-QAM
5.0	18625 / 1852.5	1 RB low	22.0	21.5
		1 RB mid	22.0	21.3
		1 RB high	21.8	21.3
		50% RB low	21.0	20.3
		50% RB mid	21.0	20.2
		50% RB high	20.9	20.1
	18900 / 1880.0	100% RB	21.0	20.1
		1 RB low	22.1	21.2
		1 RB mid	22.1	21.1
		1 RB high	22.0	21.1
		50% RB low	21.0	20.3
		50% RB mid	21.0	20.2
	19175 / 1907.5	50% RB high	21.0	20.2
		100% RB	21.0	20.1
		1 RB low	22.0	21.1
		1 RB mid	21.9	21.0
		1 RB high	21.8	20.9
		50% RB low	21.1	20.1
10.0	18650 / 1855	50% RB mid	21.0	20.1
		50% RB high	20.8	20.0
		100% RB	21.0	20.0
		1 RB low	22.2	21.6
		1 RB mid	21.8	21.4
		1 RB high	21.8	21.3
	18900 / 1880	50% RB low	21.1	20.2
		50% RB mid	20.9	20.0
		50% RB high	20.9	20.0
		100% RB	21.0	20.0
		1 RB low	22.2	21.4
		1 RB mid	21.9	21.0
	19150 / 1905	1 RB high	21.9	21.0
		50% RB low	21.1	20.3
		50% RB mid	21.1	20.2
		50% RB high	21.0	20.1
		100% RB	21.1	20.1
		1 RB low	22.1	21.2
		1 RB mid	21.8	20.9
		1 RB high	21.7	20.8
		50% RB low	21.1	20.1
		50% RB mid	20.9	20.0
		50% RB high	20.9	19.9
		100% RB	20.9	20.0

Bandwidth (MHz)	Channel / Frequency (MHz)	Resource block allocation	P _{avg} (dBm)	
			QPSK	16-QAM
15.0	18675 / 1857.5	1 RB low	22.3	21.8
		1 RB mid	21.8	21.2
		1 RB high	21.8	21.2
		50% RB low	21.2	20.3
		50% RB mid	21.0	20.1
		50% RB high	21.0	20.0
	18900 / 1880.0	100% RB	21.0	20.1
		1 RB low	22.5	21.9
		1 RB mid	21.9	21.3
		1 RB high	22.0	21.6
		50% RB low	21.2	20.3
		50% RB mid	21.0	20.1
	19125 / 1902.5	50% RB high	21.0	20.1
		100% RB	21.1	20.1
		1 RB low	22.3	21.5
		1 RB mid	21.9	21.0
		1 RB high	21.7	20.8
		50% RB low	21.2	20.2
20.0	18700 / 1860	50% RB mid	21.0	20.0
		50% RB high	20.8	19.9
		100% RB	21.0	20.0
		1 RB low	22.3	21.9
		1 RB mid	21.6	21.2
		1 RB high	21.6	21.1
	18900 / 1880	50% RB low	21.1	20.3
		50% RB mid	20.8	19.9
		50% RB high	20.8	19.9
		100% RB	21.0	20.1
		1 RB low	22.2	21.8
		1 RB mid	21.7	21.3
	19100 / 1900	1 RB high	21.5	21.1
		50% RB low	21.1	20.2
		50% RB mid	20.9	20.0
		50% RB high	20.8	19.9
		100% RB	21.0	20.1
		1 RB low	22.2	21.8
	1 RB mid	21.7	21.2	
	1 RB high	21.4	21.0	
	50% RB low	21.2	20.3	
	50% RB mid	20.9	20.0	
	50% RB high	20.8	19.9	
	100% RB	21.0	20.1	

Table 16: Test results conducted power measurement LTE FDD 2 1900MHz.

7.1.6 Conducted power measurements LTE FDD 4 1700 MHz

Bandwidth (MHz)	Channel / Frequency (MHz)	Resource block allocation	P _{avg} (dBm)	
			QPSK	16-QAM
1.4	19957 / 1710.7	1 RB low	22.6	21.9
		1 RB mid	22.5	21.9
		1 RB high	22.5	22.0
		50% RB low	22.5	21.6
		50% RB mid	22.6	21.6
		50% RB high	22.5	21.6
		100% RB	21.5	20.5
	20175 / 1732.5	1 RB low	22.4	21.4
		1 RB mid	22.3	21.3
		1 RB high	22.4	21.4
		50% RB low	22.4	21.5
		50% RB mid	22.3	21.5
		50% RB high	22.3	21.5
	20393 / 1754.3	100% RB	21.3	20.6
		1 RB low	22.3	21.3
		1 RB mid	22.2	21.3
		1 RB high	22.2	21.3
		50% RB low	22.2	21.3
50% RB mid		22.2	21.3	
3	19965 / 1711.5	50% RB high	22.2	21.3
		50% RB low	22.2	21.3
		50% RB mid	22.2	21.3
		50% RB high	22.2	21.3
		100% RB	21.2	20.5
		1 RB low	22.3	21.3
	20175 / 1732.5	1 RB mid	22.2	21.3
		1 RB high	22.2	21.3
		50% RB low	22.2	21.3
		50% RB mid	22.2	21.3
		50% RB high	22.2	21.3
		100% RB	21.2	20.5
		1 RB low	22.5	22.0
	20385 / 1753.5	1 RB mid	22.5	21.9
		1 RB high	22.4	21.9
		50% RB low	21.6	20.6
		50% RB mid	21.5	20.5
		50% RB high	21.5	20.5
100% RB		21.5	20.6	
1 RB low		22.4	21.4	
20385 / 1753.5	1 RB mid	22.3	21.3	
	1 RB high	22.3	21.2	
	50% RB low	21.4	20.7	
	50% RB mid	21.3	20.7	
	50% RB high	21.3	20.6	
	100% RB	21.3	20.4	
	1 RB low	22.2	21.2	
20385 / 1753.5	1 RB mid	22.2	21.2	
	1 RB high	22.1	21.1	
	50% RB low	21.3	20.4	
	50% RB mid	21.2	20.3	
	50% RB high	21.2	20.4	
	100% RB	21.2	20.4	

Bandwidth (MHz)	Channel / Frequency (MHz)	Resource block allocation	P _{avg} (dBm)		
			QPSK	16-QAM	
5	19975 / 1712.5	1 RB low	22.6	22.0	
		1 RB mid	22.6	21.9	
		1 RB high	22.4	21.8	
		50% RB low	21.5	20.8	
		50% RB mid	21.5	20.7	
		50% RB high	21.4	20.7	
		100% RB	21.5	20.6	
	20175 / 1732.5	1 RB low	22.4	21.5	
		1 RB mid	22.3	21.4	
		1 RB high	22.3	21.3	
		50% RB low	21.4	20.6	
		50% RB mid	21.3	20.5	
		50% RB high	21.3	20.4	
	20375 / 1752.5	1 RB low	22.3	21.4	
		1 RB mid	22.3	21.3	
		1 RB high	22.1	21.2	
		50% RB low	21.2	20.3	
		50% RB mid	21.2	20.4	
		50% RB high	21.1	20.4	
	10	20000 / 1715.0	1 RB low	22.7	22.1
			1 RB mid	22.4	21.9
1 RB high			22.3	21.8	
50% RB low			21.5	20.7	
50% RB mid			21.4	20.5	
50% RB high			21.4	20.5	
100% RB			21.4	20.6	
20175 / 1732.5		1 RB low	22.5	21.4	
		1 RB mid	22.2	21.2	
		1 RB high	22.1	21.2	
		50% RB low	21.4	20.6	
		50% RB mid	21.3	20.5	
		50% RB high	21.2	20.4	
20350 / 1750.0		1 RB low	22.3	21.4	
		1 RB mid	22.1	21.1	
		1 RB high	22.0	21.1	
		50% RB low	21.3	20.4	
		50% RB mid	21.1	20.2	
		50% RB high	21.1	20.2	
		100% RB	21.2	20.3	

Bandwidth (MHz)	Channel / Frequency (MHz)	Resource block allocation	P _{avg} (dBm)	
			QPSK	16-QAM
15	20025 / 1717.5	1 RB low	22.9	22.3
		1 RB mid	22.4	21.9
		1 RB high	22.4	21.7
		50% RB low	21.7	20.8
		50% RB mid	21.5	20.7
		50% RB high	21.4	20.6
		100% RB	21.5	20.7
	20175 / 1732.5	1 RB low	22.8	22.3
		1 RB mid	22.3	21.8
		1 RB high	22.2	21.7
		50% RB low	21.5	20.6
		50% RB mid	21.3	20.5
		50% RB high	21.2	20.3
	20325 / 1747.5	1 RB low	22.6	21.6
		1 RB mid	22.1	21.2
		1 RB high	22.1	21.1
		50% RB low	21.4	20.5
		50% RB mid	21.2	20.3
50% RB high		21.2	20.2	
20	20050 / 1720.0	1 RB low	22.9	22.5
		1 RB mid	22.2	21.9
		1 RB high	22.0	21.7
		50% RB low	21.7	20.8
		50% RB mid	21.4	20.4
		50% RB high	21.3	20.4
	20175 / 1732.5	100% RB	21.4	20.5
		1 RB low	22.6	22.3
		1 RB mid	22.0	21.7
		1 RB high	21.8	21.4
		50% RB low	21.5	20.6
		50% RB mid	21.2	20.3
	20300 / 1745.0	50% RB high	21.1	20.2
		100% RB	21.4	20.4
		1 RB low	22.6	22.1
		1 RB mid	22.0	21.5
		1 RB high	21.9	21.4
		50% RB low	21.4	20.5
	50% RB mid	21.1	20.2	
	50% RB high	21.1	20.2	
	100% RB	21.2	20.4	

Table 17: Test results conducted power measurement LTE FDD 4 1700 MHz.

7.1.7 Conducted power measurements LTE FDD 5 850 MHz

Bandwidth (MHz)	Channel / Frequency (MHz)	Resource block allocation	P _{avg} (dBm)	
			QPSK	16-QAM
1.4	20407 / 824.7	1 RB low	23.3	22.8
		1 RB mid	23.2	22.7
		1 RB high	23.3	22.8
		50% RB low	23.3	22.4
		50% RB mid	23.2	22.3
		50% RB high	23.2	22.3
	20525 / 836.5	100% RB	22.0	21.1
		1 RB low	23.0	22.2
		1 RB mid	23.1	22.0
		1 RB high	23.1	21.9
		50% RB low	23.0	22.3
		50% RB mid	23.0	22.3
	20643 / 848.3	50% RB high	23.0	22.2
		100% RB	22.0	21.3
		1 RB low	23.0	22.1
		1 RB mid	22.9	22.0
		1 RB high	22.9	22.0
		50% RB low	22.9	22.0
3.0	20415 / 825.5	50% RB mid	22.9	22.0
		50% RB high	22.9	22.0
		100% RB	21.9	21.1
		1 RB low	23.2	22.7
		1 RB mid	23.2	22.7
		1 RB high	23.1	22.6
	20525 / 836.5	50% RB low	22.1	21.2
		50% RB mid	22.2	21.0
		50% RB high	22.2	21.1
		100% RB	22.2	21.3
		1 RB low	22.9	22.1
		1 RB mid	22.9	22.1
	20635 / 847.5	1 RB high	22.9	22.0
		50% RB low	21.9	21.3
		50% RB mid	21.9	21.2
		50% RB high	21.9	21.2
		100% RB	21.9	21.0
		1 RB low	22.8	21.8
1 RB mid	22.8	21.8		
1 RB high	22.8	21.7		
50% RB low	21.9	21.0		
50% RB mid	21.8	20.9		
50% RB high	21.9	21.0		
100% RB	21.9	21.0		

Bandwidth (MHz)	Channel / Frequency (MHz)	Resource block allocation	P _{avg} (dBm)	
			QPSK	16-QAM
5.0	20425 / 826.5	1 RB low	23.2	22.6
		1 RB mid	23.2	22.6
		1 RB high	23.1	22.5
		50% RB low	22.2	21.4
		50% RB mid	22.2	21.4
		50% RB high	22.2	21.3
		100% RB	22.2	21.2
	20525 / 836.5	1 RB low	23.0	22.0
		1 RB mid	23.0	22.1
		1 RB high	22.9	22.0
		50% RB low	22.0	21.1
		50% RB mid	22.0	21.1
		50% RB high	21.9	21.0
	20625 / 846.5	1 RB low	22.9	21.9
		1 RB mid	23.0	22.0
		1 RB high	22.9	21.9
		50% RB low	22.0	21.0
		50% RB mid	21.9	21.1
50% RB high		21.7	21.0	
10.0	20450 / 829	1 RB low	23.1	22.7
		1 RB mid	23.0	22.6
		1 RB high	22.8	22.3
		50% RB low	22.1	21.2
		50% RB mid	22.1	21.1
		50% RB high	22.0	21.0
	20525 / 836.5	100% RB	22.1	21.1
		1 RB low	23.0	22.2
		1 RB mid	23.0	22.1
		1 RB high	22.7	21.8
		50% RB low	22.0	21.1
		50% RB mid	21.9	21.1
	20600 / 844	50% RB high	21.9	21.1
		100% RB	21.9	20.9
		1 RB low	22.8	21.8
		1 RB mid	22.8	21.8
		1 RB high	22.6	21.6
		50% RB low	21.8	20.9
	50% RB mid	21.8	20.8	
	50% RB high	21.9	20.8	
	100% RB	21.9	20.9	

Table 18: Test results conducted power measurement LTE FDD 5 850 MHz.

7.1.8 Conducted power measurements LTE FDD 12 700 MHz

Bandwidth (MHz)	Channel / Frequency (MHz)	Resource block allocation	P _{avg} (dBm)	
			QPSK	16-QAM
1.4	23017 / 699.7	1 RB low	23.3	23.0
		1 RB mid	23.3	22.9
		1 RB high	23.4	22.9
		50% RB low	23.3	22.5
		50% RB mid	23.4	22.5
		50% RB high	23.4	22.5
		100% RB	22.3	21.3
	23095 / 707.5	1 RB low	23.3	22.3
		1 RB mid	23.4	22.1
		1 RB high	23.4	22.3
		50% RB low	23.3	22.5
		50% RB mid	23.3	22.5
		50% RB high	23.2	22.4
	23173 / 715.3	100% RB	22.2	21.4
		1 RB low	23.2	22.3
		1 RB mid	23.2	22.3
		1 RB high	23.2	22.4
		50% RB low	23.1	22.3
50% RB mid		23.2	22.3	
3	23025 / 700.5	50% RB high	23.2	22.3
		100% RB	22.1	21.3
		1 RB low	23.4	22.9
		1 RB mid	23.3	22.9
		1 RB high	23.3	22.9
		50% RB low	22.4	21.3
		50% RB mid	22.4	21.2
	23095 / 707.5	50% RB high	22.3	21.2
		100% RB	22.3	21.3
		1 RB low	23.3	22.5
		1 RB mid	23.3	22.3
		1 RB high	23.2	22.3
		50% RB low	22.2	21.5
		50% RB mid	22.2	21.5
	23165 / 714.5	50% RB high	22.2	21.4
		100% RB	22.2	21.1
		1 RB low	23.0	22.1
		1 RB mid	23.1	22.1
1 RB high		23.1	22.0	
50% RB low		22.1	21.0	
50% RB mid		22.1	21.1	
50% RB high	22.1	21.1		
100% RB	22.1	21.1		

Bandwidth (MHz)	Channel / Frequency (MHz)	Resource block allocation	P _{avg} (dBm)	
			QPSK	16-QAM
5	21475 / 882.5	1 RB low	23.3	22.8
		1 RB mid	23.5	22.7
		1 RB high	23.3	22.6
		50% RB low	22.3	21.5
		50% RB mid	22.3	21.5
		50% RB high	22.2	21.4
		100% RB	22.3	21.2
	23095 / 707.5	1 RB low	23.2	22.3
		1 RB mid	23.2	22.4
		1 RB high	23.1	22.2
		50% RB low	22.2	21.3
		50% RB mid	22.2	21.2
		50% RB high	22.1	21.2
	23155 / 713.5	1 RB low	23.1	22.3
		1 RB mid	23.2	22.3
		1 RB high	23.1	22.1
		50% RB low	22.1	21.1
		50% RB mid	22.1	21.1
50% RB high		22.0	21.1	
10	23060 / 704	1 RB low	23.3	22.8
		1 RB mid	23.3	22.8
		1 RB high	23.0	22.6
		50% RB low	22.2	21.2
		50% RB mid	22.2	21.2
		50% RB high	22.2	21.1
	23095 / 707.5	100% RB	22.2	21.1
		1 RB low	23.2	22.3
		1 RB mid	23.2	22.2
		1 RB high	22.9	22.1
		50% RB low	22.2	21.2
		50% RB mid	22.1	21.2
	23130 / 711	50% RB high	22.1	21.1
		100% RB	22.1	21.1
		1 RB low	23.1	22.1
		1 RB mid	23.1	22.1
		1 RB high	23.0	22.0
		50% RB low	22.2	21.1
	50% RB mid	22.1	21.1	
	50% RB high	22.0	21.0	
	100% RB	22.1	21.0	

Table 19: Test results conducted power measurement LTE FDD12 700 MHz.

7.1.9 Justification of SAR measurements in LTE mode

According to Chapter 5 'SAR test procedures for LTE devices of FCC KDB Publication 941225 D05 the following test configurations for standalone measurements of the largest channel bandwidth (chapter 5.2) had to be taken into consideration:

5.2.1. QPSK with 1 RB allocation

Start with the largest channel bandwidth and measure SAR for QPSK with 1 RB allocation, using the RB offset and *required test channel* combination with the highest maximum output power for RB offsets at the upper edge, middle and lower edge of each *required test channel*. When the *reported SAR* is ≤ 0.8 W/kg, testing of the remaining RB offset configurations and *required test channels* is not required for 1 RB allocation; otherwise, SAR is required for the remaining *required test channels* and only for the RB offset configuration with the highest output power for that channel.⁶ When the *reported SAR* of a *required test channel* is > 1.45 W/kg, SAR is required for all three RB offset configurations for that *required test channel*.

5.2.2. QPSK with 50% RB allocation

The procedures required for 1 RB allocation in 5.2.1 are applied to measure the SAR for QPSK with 50% RB allocation.

5.2.3. QPSK with 100% RB allocation

For QPSK with 100% RB allocation, SAR is not required when the highest maximum output power for 100 % RB allocation is less than the highest maximum output power in 50% and 1 RB allocations and the highest *reported SAR* for 1 RB and 50% RB allocation in 5.2.1 and 5.2.2 are ≤ 0.8 W/kg. Otherwise, SAR is measured for the highest output power channel and if the *reported SAR* is > 1.45 W/kg, the remaining *required test channels* must also be tested.

5.2.4. Higher order modulations

For each modulation besides QPSK; e.g., 16-QAM, 64-QAM, apply the QPSK procedures in sections 5.2.1, 5.2.2 and 5.2.3 to determine the QAM configurations that may need SAR measurement. For each configuration identified as required for testing, SAR is required only when the highest maximum output power for the configuration in the higher order modulation is $> \frac{1}{2}$ dB higher than the same configuration in QPSK or when the *reported SAR* for the QPSK configuration is > 1.45 W/kg.

Testing of other channel bandwidths was not necessary because the output power of equivalent channel configurations was less than $\frac{1}{2}$ dB larger compared to the largest channel bandwidth and reported SAR was < 1.45 W/kg.

Conducted and radiated measurements were performed with the maximum number of bundled TTIs supported by the DUT (see section 2.4 for details).

7.1.10 MPR information in LTE mode

There is a permanently applied MPR implemented by the manufacturer. MPR is enabled for this device according to 3GPP TS36.101.

Modulation	Channel bandwidth / resource block configuration						Target MPR	3 GPP MPR
	1.4 MHz	3 MHz	5 MHz	10 MHz	15 MHz	20 MHz		
QPSK	> 5	> 4	> 8	> 12	> 16	> 18	1	≤ 1
16QAM	≤ 5	≤ 4	≤ 8	≤ 12	≤ 16	≤ 18	1	≤ 1
16QAM	> 5	> 4	> 8	> 12	> 16	> 18	2	≤ 2

Therefore there is no power reduction at 1.4 MHz bandwidth with 50% RB allocation (3 RBs).

Additional differences in conducted power are not caused by implemented MPR but depend on measurement uncertainty and allowable tolerances per 3GPP or tune-up. A-MPR was disabled for all SAR tests.

7.1.11 Conducted power measurements WLAN 2450 MHz

802.11b		maximum average conducted output power [dBm]			
Band	Ch	1Mbps	2Mbps	5.5Mbps	11Mbps
2450MHz	1	6.0	6.0	5.9	5.9
	6	5.4	5.4	5.3	5.3
	11	5.6	5.6	5.5	5.5

Table 20: Test results conducted power measurement 802.11b

802.11g		maximum average conducted output power [dBm]							
Band	Ch	6Mbps	9Mbps	12Mbps	18Mbps	24Mbps	36Mbps	48Mbps	54Mbps
2450MHz	1	6.1	6.0	5.9	6.0	5.9	5.7	5.7	5.7
	2	6.0	5.9	5.8	5.9	5.8	5.6	5.6	5.6
	6	6.0	5.9	5.8	5.9	5.9	5.7	5.7	5.7
	10	5.7	5.6	5.5	5.5	5.5	5.3	5.3	5.3
	11	5.7	5.6	5.5	5.5	5.5	5.3	5.3	5.3

Table 21: Test results conducted power measurement 802.11g

802.11n HT-20		maximum average conducted output power [dBm]							
Band	Ch	MCS-0	MCS-1	MCS-2	MCS-3	MCS-4	MCS-5	MCS-6	MCS-7
		6.5Mbps	13Mbps	19.5Mbps	26Mbps	39Mbps	52Mbps	58.5Mbps	65Mbps
2450MHz	1	6.0	5.9	5.9	5.9	5.8	5.8	5.7	5.5
	2	5.9	5.8	5.8	5.9	5.8	5.8	5.7	5.5
	6	5.8	5.7	5.7	5.8	5.7	5.7	5.6	5.4
	10	5.6	5.5	5.5	5.6	5.4	5.5	5.4	5.2
	11	5.6	5.5	5.5	5.5	5.4	5.4	5.3	5.2

Table 22: Test results conducted power measurement 802.11n HT-20

802.11n HT-40		maximum average conducted output power [dBm]							
Band	Ch	MCS-0	MCS-1	MCS-2	MCS-3	MCS-4	MCS-5	MCS-6	MCS-7
		13.5Mbps	27Mbps	40.5Mbps	54Mbps	81Mbps	108Mbps	121.5Mbps	135Mbps
2450MHz	3	4.0	4.3	4.2	4.3	4.3	4.2	4.2	4.2
	6	5.5	5.8	5.7	5.8	5.8	5.7	5.7	5.7
	9	3.6	3.9	3.8	3.9	3.9	3.8	3.8	3.8

Table 23: Test results conducted power measurement 802.11n HT-40

7.1.12 Conducted power measurements WLAN 5 GHz

802.11a		maximum average conducted output power [dBm]							
Band	Ch	6Mbps	9Mbps	12Mbps	18Mbps	24Mbps	36Mbps	48Mbps	54Mbps
5200	36	0.3	0.3	0.2	0.2	0.2	0.2	-0.2	-0.2
	40	0.3	0.3	0.3	0.3	0.2	0.2	-0.2	-0.2
	44	0.3	0.3	0.3	0.2	0.2	0.2	-0.2	-0.2
	48	0.2	0.2	0.2	0.2	0.2	0.2	-0.1	-0.1
5300	52	0.5	0.5	0.4	0.4	0.4	0.4	0.0	-0.1
	56	0.8	0.8	0.7	0.7	0.6	0.6	0.1	0.1
	60	0.9	0.9	0.8	0.8	0.8	0.7	0.2	0.1
	64	1.1	1.1	1.0	1.0	1.0	1.0	0.5	0.4
5600	100	1.7	1.7	1.6	1.6	1.6	1.6	1.1	1.1
	104	1.8	1.8	1.7	1.7	1.7	1.7	1.2	1.2
	108	1.7	1.7	1.7	1.6	1.6	1.6	1.0	0.9
	112	1.8	1.8	1.7	1.7	1.7	1.7	1.2	1.2
	116	2.0	2.0	1.9	1.8	1.8	1.8	1.3	1.2
	120	1.9	1.9	1.8	1.8	1.8	1.8	1.3	1.3
	124	2.1	2.1	2.0	2.0	1.9	1.9	1.4	1.4
	128	2.0	2.0	1.9	1.9	1.9	1.9	1.4	1.3
	132	1.9	1.9	1.8	1.8	1.8	1.8	1.3	1.3
	136	2.2	2.2	2.1	2.1	2.0	2.0	1.5	1.5
5800	140	2.7	2.7	2.6	2.6	2.6	2.5	2.0	1.9
	149	3.2	3.2	3.1	3.1	3.1	3.1	2.6	2.5
	153	2.1	2.1	2.0	2.0	2.0	2.0	1.4	1.4
	157	1.3	1.3	1.3	1.2	1.2	1.1	1.6	1.5
	161	1.2	1.2	1.2	1.1	1.1	1.1	1.6	1.5
	165	0.8	0.8	0.7	0.6	0.6	0.6	0.1	0.1

Table 24: Test results conducted power measurement 802.11a

802.11n HT-20 / 802.11ac VHT-20 maximum average conducted output power [dBm]									
Band [MHz]	Ch	MCS-0 6.5Mbps	MCS-1 13Mbps	MCS-2 19.5Mbps	MCS-3 26Mbps	MCS-4 39Mbps	MCS-5 52Mbps	MCS-6 58.5Mbps	MCS-7 65Mbps
5200	36	-0.5	-0.6	-0.3	-0.4	-0.5	-0.1	-0.4	-0.2
	40	-0.7	-0.8	-0.5	-0.5	-0.6	-0.3	-0.5	-0.4
	44	-0.8	-0.7	-0.3	-0.4	-0.4	-0.1	-0.4	-0.1
	48	-0.9	-0.9	-0.6	-0.6	-0.6	-0.4	-0.6	-0.5
5300	52	-0.4	-0.4	-0.1	-0.2	-0.2	-0.1	-0.2	-0.2
	56	-0.1	-0.1	0.2	0.2	0.2	0.5	0.2	0.4
	60	-0.3	-0.4	-0.1	-0.1	-0.1	0.2	-0.1	0.1
	64	-0.1	-0.1	0.2	0.2	0.2	0.5	0.2	0.4
5600	100	0.6	0.6	0.9	0.9	0.8	1.1	0.9	1.0
	104	0.8	0.8	1.1	1.0	1.0	1.3	1.0	1.2
	108	0.7	0.7	1.0	1.0	0.9	1.2	1.0	1.1
	112	0.9	0.9	1.2	1.2	1.2	1.5	1.2	1.3
	116	1.1	1.0	1.3	1.2	1.1	1.3	1.2	1.2
	120	1.4	1.4	1.7	1.7	1.6	1.9	1.7	1.6
	124	1.7	1.6	1.9	1.8	1.8	1.9	1.8	1.7
	128	1.5	1.4	1.7	1.7	1.7	1.8	1.7	1.6
	132	1.4	1.3	1.6	1.6	1.6	1.9	1.6	1.7
	136	1.7	1.6	1.9	1.8	1.8	2.1	1.8	2.0
140	1.7	1.7	2.0	1.9	1.9	2.1	1.9	1.9	
5800	149	1.8	1.8	2.1	2.1	2.1	2.3	2.0	2.2
	153	1.0	-0.9	-0.6	-0.6	-0.7	-0.3	-0.6	-0.4
	157	0.1	0.1	0.4	0.3	0.3	0.7	0.4	0.5
	161	0.0	-0.9	-0.6	-0.7	-0.8	-0.5	-0.6	-0.7
	165	-0.2	-0.2	0.1	0.1	0.0	0.4	0.1	0.2

Table 25: Test results conducted power measurement 802.11n HT-20 / 802.11ac VHT-20

802.11n HT-40 / 802.11ac VHT-40 maximum average conducted output power [dBm]									
Band [MHz]	Ch	MCS-0 13.5Mbps	MCS-1 27Mbps	MCS-2 40.5Mbps	MCS-3 54Mbps	MCS-4 81Mbps	MCS-5 108Mbps	MCS-6 121.5Mbps	MCS-7 135Mbps
5200	38	-2.9	-3.0	-3.0	-3.1	-3.1	-3.1	-2.8	-3.0
	46	-3.3	-3.4	-3.3	-3.3	-3.3	-3.5	-3.1	-3.3
5300	54	-3.3	-3.3	-3.3	-3.4	-3.3	-3.3	-3.2	-3.3
	62	-3.7	-3.6	-3.5	-3.5	-3.5	-3.5	-3.5	-3.5
5600	102	-1.9	-1.8	-1.8	-1.9	-1.9	-1.4	-1.7	-1.7
	110	-1.9	-1.9	-1.9	-1.9	-1.9	-1.9	-1.8	-1.8
	118	-1.5	-1.5	-1.5	-1.6	-1.6	-1.6	-1.3	-1.4
	126	-1.4	-1.5	-1.4	-1.5	-1.4	-1.5	-1.3	-1.5
	134	-1.8	-1.9	-1.7	-1.7	-1.7	-1.8	-1.6	-1.7
5800	151	-0.2	-0.2	-0.3	-0.4	-0.3	-0.2	-0.1	-0.2
	159	-1.8	-1.7	-1.7	-1.8	-1.7	-1.9	-1.7	-1.9

Table 26: Test results conducted power measurement 802.11n HT-40 / 802.11ac VHT-40

7.1.1 Conducted average power measurements Bluetooth 2.4 GHz

Channel	Frequency (MHz)	GFSK	upper limit	antenna gain
0	2402	6.3	7.0	-0.4
39	2441	10.0	10.5	5.7
78	2480	15.4	16.0	5.1

Table 27: Test results conducted average power measurement Bluetooth 2.4 GHz

7.1.2 Standalone SAR Test Exclusion according to FCC KDB 447498 D01

Standalone SAR test exclusion considerations							
Communication system	freq. (MHz)	distance (mm)	P _{avg} * (dBm)	P _{avg} * (mW)	threshold _{1g} comparison value	SAR _{1g} test exclusion thresholds	SAR _{1g} test exclusion
WLAN 5.2 GHz	5200	5	1.0	1.3	0.6	7.5	yes
WLAN 5.3 GHz	5300	5	1.5	1.4	0.7	7.5	yes
WLAN 5.6 GHz	5600	5	3.0	2.0	0.9	7.5	yes
WLAN 5.8 GHz	5800	5	3.5	2.2	1.1	7.5	yes

Table 28: Standalone SAR test exclusion considerations

P_{avg}* - maximum possible output power declared by manufacturer

The **10-g SAR test exclusion thresholds** for 100 MHz to 6 GHz at *test separation distances* ≤ 50 mm are determined by:

$[(\text{max. power of channel, including tune-up tolerance, mW}) / (\text{min. test separation distance, mm})] \times [\sqrt{f(\text{GHz})}] \leq 3.0$ for 1-g SAR and ≤ **7.5** for 10-g extremity SAR, where:

- f(GHz) is the RF channel transmit frequency in GHz
- Power and distance are rounded to the nearest mW and mm before calculation
- The result is rounded to one decimal place for comparison

When the minimum test separation distance is < 5 mm, a distance of 5 mm is applied to determine SAR test exclusion

7.1.3 Standalone SAR Test Exclusion according to RSS-102 Issue 5

Standalone SAR test exclusion considerations						
Communication system	freq. (MHz)	distance (mm)	P _{avg} * (dBm)	P _{avg} * (mW)	Exemption Limits _{1g} (mW)	SAR test exclusion
WLAN 5.2 GHz	5200	5	1.0	1.3	2.5	yes
WLAN 5.3 GHz	5300	5	1.5	1.4	2.5	yes
WLAN 5.6 GHz	5600	5	3.0	2.0	2.5	yes
WLAN 5.8 GHz	5800	5	3.5	2.2	2.5	yes

Table 29: Standalone SAR test exclusion considerations

P_{avg}* - maximum possible output power declared by manufacturer. Output power level shall be the higher of the maximum conducted or equivalent isotropically radiated power (e.i.r.p.) source-based, time-averaged output power.

For limb-worn devices where the **10g** value applies, the exemption limits for routine evaluation in Table 1 are multiplied by a factor of **2.5**. If the operating frequency of the device is between two frequencies located in Table, linear interpolation shall be applied for the applicable separation distance. For test separation distance less than 5 mm, the exemption limits for a separation distance of 5 mm can be applied to determine if a routine evaluation is required.

7.2 SAR test results

7.2.1 General description of test procedures

- The DUT is tested using CMU 200 and CMW 500 communications testers as controller unit to set test channels and maximum output power to the DUT, as well as for measuring the conducted peak power.
- Test positions as described in the tables above are in accordance with the specified test standard.
- UMTS was tested in RMC mode with 12.2 kbit/s and TPC bits set to 'all 1'.
- WLAN was tested in 802.11a/b mode with 1 MBit/s and 6 MBit/s.
- Required WLAN test channels were selected according to KDB 248227
- The DUT was tested using a CBT communication tester in BT-test mode to adjust maximum output power, test channels and operating mode.
(GFSK - DH5 - STATIC PBRs - 76% duty cycle)
- According to IEEE 1528 the SAR test shall be performed at middle channel. Testing of top and bottom channel is optional.
- According to KDB 447498 D01 testing of other required channels within the operating mode of a frequency band is not required when the reported 1-g or 10-g SAR for the mid-band or highest output power channel is:
 - ≤ 0.8 W/kg or 2.0 W/kg, for 1-g or 10-g respectively, when the transmission band is ≤ 100 MHz
 - ≤ 0.6 W/kg or 1.5 W/kg, for 1-g or 10-g respectively, when the transmission band is between 100 MHz and 200 MHz
 - ≤ 0.4 W/kg or 1.0 W/kg, for 1-g or 10-g respectively, when the transmission band is ≥ 200 MHz
- IEEE 1528-2013 requires the middle channel to be tested first. This generally applies to wireless devices that are designed to operate in technologies with tight tolerances for maximum output power variations across channels in the band. When the maximum output power variation across the required test channels is $> \frac{1}{2}$ dB, instead of the middle channel, the highest output power channel must be used.

7.2.2 Results overview

measured / extrapolated SAR numbers - Extremities - UMTS FDD II 1900MHz - Limit for 10g: 4W/kg										
Ch.	Freq. (MHz)	test cond.	Position	cond. P _{max} (dBm)		SAR _{10g} (W/kg)		power drift (dB)	liquid (°C)	dist. (mm)
				declared**	meas.	meas.	extrap.			
Move 5000										
9538	1907.6	RMC	top	23.5	23.0	0.156	0.175	-0.03	22.4	0
9538	1907.6	RMC	bottom	23.5	23.0	0.173	0.194	0.06	22.4	0
9262	1852.4	RMC	left	23.5	22.7	1.430	1.719	-0.10	22.4	0
9400	1880.0	RMC	left	23.5	22.7	1.290	1.551	-0.11	22.4	0
9538	1907.6	RMC	left	23.5	23.0	1.290	1.447	-0.10	22.4	0
9538	1907.6	RMC	right	23.5	23.0	0.127	0.142	-0.15	22.4	0
9538	1907.6	RMC	front	23.5	23.0	0.039	0.043	0.19	22.4	0
9538	1907.6	RMC	rear	23.5	23.0	0.105	0.118	-0.35	22.4	0
Move 3500										
9538	1907.6	RMC	top	23.5	23.0	0.174	0.195	0.05	21.7	0
9538	1907.6	RMC	bottom	23.5	23.0	0.215	0.241	0.00	21.7	0
9262	1852.4	RMC	left	23.5	22.7	2.340	2.813	0.00	21.7	0
9400	1880.0	RMC	left	23.5	22.7	2.110	2.537	0.00	21.7	0
9538	1907.6	RMC	left	23.5	23.0	2.090	2.345	0.01	21.7	0
9538	1907.6	RMC	right	23.5	23.0	0.152	0.171	-0.16	21.7	0
9538	1907.6	RMC	front	23.5	23.0	0.078	0.088	0.08	21.7	0
9538	1907.6	RMC	rear	23.5	23.0	0.021	0.023	-0.10	21.7	0
9262	1852.4	RMC	left*	23.5	22.7	2.060	2.477	0.00	21.7	0

Table 30: Test results SAR UMTS FDD II 1880 MHz (see max. SAR plot on page 65.)

* - repeated at the highest SAR measurement according to the FCC KDB 865664

** - maximum possible output power declared by manufacturer

measured / extrapolated SAR numbers - Extremities - UMTS FDD IV 1700MHz - Limit for 10g: 4W/kg										
Ch.	Freq. (MHz)	test cond.	Position	cond. P _{max} (dBm)		SAR _{10g} (W/kg)		power drift (dB)	liquid (°C)	dist. (mm)
				declared**	meas.	meas.	extrap.			
Move 5000										
1412	1732.4	RMC	top	23.0	22.8	0.144	0.151	0.13	20.9	0
1412	1732.4	RMC	bottom	23.0	22.8	0.303	0.317	-0.03	20.9	0
1312	1712.4	RMC	left	23.0	22.8	2.270	2.377	-0.08	20.9	0
1412	1732.4	RMC	left	23.0	22.8	2.360	2.471	-0.01	20.9	0
1513	1752.6	RMC	left	23.0	22.7	2.140	2.293	-0.13	20.9	0
1412	1732.4	RMC	right	23.0	22.8	0.271	0.284	0.03	20.9	0
1412	1732.4	RMC	front	23.0	22.8	0.045	0.047	-0.01	20.9	0
1412	1732.4	RMC	rear	23.0	22.8	0.098	0.102	0.17	20.9	0
1412	1732.4	RMC	left (WC)	23.0	22.8	2.480	2.597	-0.04	20.9	0
Move 3500										
1312	1712.4	RMC	left	23.0	22.8	1.890	1.979	-0.14	22.4	0
1412	1732.4	RMC	left	23.0	22.8	2.060	2.157	-0.19	22.4	0
1513	1752.6	RMC	left	23.0	22.7	2.020	2.164	-0.11	22.4	0

Table 31: Test results SAR UMTS FDD IV 1700 MHz MHz (see max. SAR plot on page 66.)

* - repeated at the highest SAR measurement according to the FCC KDB 865664

** - maximum possible output power declared by manufacturer

measured / extrapolated SAR numbers - Extremities - UMTS FDD V 85 MHz - Limit for 10g: 4W/kg										
Ch.	Freq. (MHz)	test cond.	Position	cond. P _{max} (dBm)		SAR _{10g} (W/kg)		power drift (dB)	liquid (°C)	dist. (mm)
				declared**	meas.	meas.	extrap.			
Move 5000										
4182	836.4	RMC	top	24.0	23.4	0.105	0.121	-0.11	23.4	0
4182	836.4	RMC	bottom	24.0	23.4	0.084	0.097	-0.04	23.4	0
4132	826.4	RMC	left	24.0	23.3	0.419	0.492	0.04	23.4	0
4182	836.4	RMC	left	24.0	23.4	0.403	0.463	-0.08	23.4	0
4233	846.6	RMC	left	24.0	23.4	0.398	0.457	-0.01	23.4	0
4182	836.4	RMC	right	24.0	23.4	0.055	0.063	-0.18	23.4	0
4182	836.4	RMC	front	24.0	23.4	0.029	0.034	-0.06	23.4	0
4182	836.4	RMC	rear	24.0	23.4	0.018	0.021	0.06	23.4	0
Move 3500										
4182	836.4	RMC	top	24.0	23.4	0.205	0.235	0.01	22.7	0
4182	836.4	RMC	bottom	24.0	23.4	0.131	0.150	0.03	22.7	0
4132	826.4	RMC	left	24.0	23.3	0.537	0.631	-0.16	22.7	0
4182	836.4	RMC	left	24.0	23.4	0.472	0.542	-0.13	22.7	0
4233	846.6	RMC	left	24.0	23.4	0.423	0.486	-0.15	22.7	0
4182	836.4	RMC	right	24.0	23.4	0.066	0.076	-0.15	22.7	0
4182	836.4	RMC	front	24.0	23.4	0.006	0.007	0.13	22.7	0
4182	836.4	RMC	rear	24.0	23.4	0.033	0.038	0.03	22.7	0

Table 32: Test results SAR UMTS FDD V 850 MHz (see max. SAR plot on page 67)

** - maximum possible output power declared by manufacturer

measured / extrapolated SAR numbers - Extremities - LTE FDD 2 1900MHz - Limit for 10g: 4W/Kg

Ch.	Freq. (MHz)	RB offset	Position	cond. P _{max} (dBm)		SAR _{10g} (W/kg)		power drift (dB)	liquid (°C)	dist. (mm)
				declared**	meas.	meas.	extrap.			
20MHz BW/1RB/QPSK - MOVE5000										
18700	1860	0	top	22.5	22.3	0.140	0.147	0.01	22.4	0
18700	1860	0	bottom	22.5	22.3	0.131	0.137	-0.14	22.4	0
18700	1860	0	left	22.5	22.3	1.270	1.330	0.01	22.4	0
18900	1880	0	left	22.5	22.2	1.200	1.286	0.01	22.4	0
19100	1900	0	left	22.5	22.2	1.160	1.243	0.09	22.4	0
18700	1860	0	right	22.5	22.3	0.155	0.162	-0.05	22.4	0
18700	1860	0	front	22.5	22.3	0.042	0.044	-0.16	22.4	0
18700	1860	0	rear	22.5	22.3	0.032	0.033	-0.02	22.4	0
20MHz BW/50RB/QPSK - MOVE5000										
19100	1900	0	top	21.5	21.2	0.100	0.107	0.17	22.4	0
19100	1900	0	bottom	21.5	21.2	0.098	0.105	0.11	22.4	0
19100	1900	0	left	21.5	21.2	0.925	0.991	-0.03	22.4	0
19100	1900	0	right	21.5	21.2	0.107	0.115	0.11	22.4	0
19100	1900	0	front	21.5	21.2	0.046	0.049	-0.13	22.4	0
19100	1900	0	rear	21.5	21.2	0.028	0.030	0.05	22.4	0
20MHz BW/1RB/QPSK - MOVE3500										
18700	1860	0	top	22.5	22.3	0.155	0.162	0.05	21.7	0
18700	1860	0	bottom	22.5	22.3	0.238	0.249	0.08	21.7	0
18700	1860	0	left	22.5	22.3	2.010	2.105	0.06	21.7	0
18900	1880	0	left	22.5	22.2	1.970	2.111	0.04	21.7	0
19100	1900	0	left	22.5	22.2	1.980	2.122	0.01	21.7	0
18700	1860	0	right	22.5	22.3	0.128	0.134	-0.13	21.7	0
18700	1860	0	front	22.5	22.3	0.089	0.093	-0.03	21.7	0
18700	1860	0	rear	22.5	22.3	0.029	0.031	-0.17	21.7	0
18700	1860	0	left*	22.5	22.3	2.080	2.178	-0.04	21.7	0
20MHz BW/50RB/QPSK - MOVE3500										
19100	1900	0	top	21.5	21.2	0.133	0.143	0.10	21.7	0
19100	1900	0	bottom	21.5	21.2	0.160	0.171	0.05	21.7	0
19100	1900	0	left	21.5	21.2	1.430	1.532	0.09	21.7	0
19100	1900	0	right	21.5	21.2	0.078	0.084	-0.07	21.7	0
19100	1900	0	front	21.5	21.2	0.066	0.071	0.16	21.7	0
19100	1900	0	rear	21.5	21.2	0.020	0.021	0.05	21.7	0
20MHz BW/100RB/QPSK - MOVE3500										
19100	1900	0	top	21.5	21.2	0.129	0.138	0.06	21.7	0
19100	1900	0	bottom	21.5	21.2	0.151	0.162	-0.04	21.7	0
19100	1900	0	left	21.5	21.2	1.160	1.243	-0.04	21.7	0
19100	1900	0	right	21.5	21.2	0.077	0.083	0.10	21.7	0
19100	1900	0	front	21.5	21.2	0.064	0.068	0.07	21.7	0
19100	1900	0	rear	21.5	21.2	0.020	0.021	-0.02	21.7	0

Table 33: Test results SAR LTE FDD 2 1900 MHz (see max. SAR plot on page 68.)

* - repeated at the highest SAR measurement according to the FCC KDB 865664

** - maximum possible output power declared by manufacturer

measured / extrapolated SAR numbers - Extremities - LTE FDD 4 1750MHz - Limit for 10g: 4W/Kg										
Ch.	Freq. (MHz)	RB offset	Position	cond. P _{max} (dBm)		SAR _{10g} (W/kg)		power drift (dB)	liquid (°C)	dist. (mm)
				declared**	meas.	meas.	extrap.			
20MHz BW/1RB/QPSK - MOVE5000										
20050	1720.0	0	top	23.0	22.9	0.113	0.116	0.14	20.8	0
20050	1720.0	0	bottom	23.0	22.9	0.341	0.349	0.04	20.8	0
20050	1720.0	0	left	23.0	22.9	2.170	2.221	-0.12	20.8	0
20175	1732.5	0	left	23.0	22.6	2.190	2.401	-0.04	20.8	0
20300	1745.0	0	left	23.0	22.6	2.260	2.478	-0.03	20.8	0
20050	1720.0	0	right	23.0	22.9	0.263	0.269	0.12	20.8	0
20050	1720.0	0	front	23.0	22.9	0.042	0.043	-0.05	20.8	0
20050	1720.0	0	rear	23.0	22.9	0.029	0.030	0.00	20.8	0
20300	1745.0	0	left (WC)	23.0	22.6	2.220	2.434	-0.19	20.8	0
20MHz BW/50RB/QPSK - MOVE5000										
20050	1720.0	0	top	22.0	21.7	0.090	0.096	0.18	20.8	0
20050	1720.0	0	bottom	22.0	21.7	0.265	0.284	-0.02	20.8	0
20050	1720.0	0	left	22.0	21.7	1.830	1.961	-0.03	20.8	0
20050	1720.0	0	right	22.0	21.7	0.216	0.231	-0.03	20.8	0
20050	1720.0	0	front	22.0	21.7	0.036	0.039	-0.01	20.8	0
20050	1720.0	0	rear	22.0	21.7	0.024	0.026	-0.02	20.8	0
20MHz BW/100RB/QPSK - MOVE5000										
20050	1720.0	0	top	22.0	21.4	0.087	0.099	0.13	20.8	0
20050	1720.0	0	bottom	22.0	21.4	0.241	0.277	0.06	20.8	0
20050	1720.0	0	left	22.0	21.4	1.680	1.929	-0.03	20.8	0
20050	1720.0	0	right	22.0	21.4	0.219	0.251	0.19	20.8	0
20050	1720.0	0	front	22.0	21.4	0.039	0.045	0.08	20.8	0
20050	1720.0	0	rear	22.0	21.4	0.024	0.027	0.13	20.8	0
20MHz BW/1RB/QPSK - MOVE3500										
20050	1720.0	0	left	23.0	22.9	1.980	2.026	-0.02	22.4	0
20175	1732.5	0	left	23.0	22.6	2.070	2.270	0.06	22.4	0
20300	1745.0	0	left	23.0	22.6	2.090	2.292	0.09	22.4	0

Table 34: Test results SAR LTE FDD 4 1750 MHz (see max. SAR plot on page 69.)

* - repeated at the highest SAR measurement according to the FCC KDB 865664

** - maximum possible output power declared by manufacturer

measured / extrapolated SAR numbers - Extremities - LTE FDD 5 850MHz - Limit for 10g: 4W/Kg										
Ch.	Freq. (MHz)	RB offset	Position	cond. P _{max} (dBm)		SAR _{10g} (W/kg)		power drift (dB)	liquid (°C)	dist. (mm)
				declared**	meas.	meas.	extrap.			
10MHz BW/1RB/QPSK - MOVE /5000										
20450	829.0	0	top	24.0	23.1	0.145	0.178	0.02	22.7	0
20450	829.0	0	bottom	24.0	23.1	0.085	0.104	0.14	22.7	0
20450	829.0	0	left	24.0	23.1	0.438	0.539	0.00	22.7	0
20525	836.5	0	left	24.0	23.0	0.414	0.521	0.03	22.7	0
20600	844.0	0	left	24.0	22.8	0.361	0.476	0.00	22.7	0
20450	829.0	0	right	24.0	23.1	0.051	0.063	-0.04	22.7	0
20450	829.0	0	front	24.0	23.1	0.004	0.005	0.17	22.7	0
20450	829.0	0	rear	24.0	23.1	0.019	0.024	-0.19	22.7	0
10MHz BW/25RB/QPSK - MOVE /5000										
20450	829.0	0	top	23.0	22.8	0.107	0.112	0.15	22.7	0
20450	829.0	0	bottom	23.0	22.8	0.066	0.069	0.05	22.7	0
20450	829.0	0	left	23.0	22.8	0.385	0.403	0.08	22.7	0
20450	829.0	0	right	23.0	22.8	0.043	0.045	0.05	22.7	0
20450	829.0	0	front	23.0	22.8	0.004	0.005	0.15	22.7	0
20450	829.0	0	rear	23.0	22.8	0.016	0.017	-0.18	22.7	0
10MHz BW/1RB/QPSK - MOVE3500										
20450	829.0	0	top	24.0	23.1	0.217	0.267	0.14	22.7	0
20450	829.0	0	bottom	24.0	23.1	0.150	0.185	-0.04	22.7	0
20450	829.0	0	left	24.0	23.1	0.574	0.706	-0.09	22.7	0
20525	836.5	0	left	24.0	23.0	0.512	0.645	-0.07	22.7	0
20600	844.0	0	left	24.0	22.8	0.465	0.613	-0.01	22.7	0
20450	829.0	0	right	24.0	23.1	0.087	0.107	0.09	22.7	0
20450	829.0	0	front	24.0	23.1	0.007	0.009	0.04	22.7	0
20450	829.0	0	rear	24.0	23.1	0.032	0.039	0.17	22.7	0
10MHz BW/25RB/QPSK - MOVE3500										
20450	829.0	0	top	23.0	22.8	0.174	0.182	0.04	22.7	0
20450	829.0	0	bottom	23.0	22.8	0.117	0.123	0.07	22.7	0
20450	829.0	0	left	23.0	22.8	0.440	0.461	-0.03	22.7	0
20450	829.0	0	right	23.0	22.8	0.064	0.067	-0.13	22.7	0
20450	829.0	0	front	23.0	22.8	0.005	0.006	0.03	22.7	0
20450	829.0	0	rear	23.0	22.8	0.025	0.026	0.13	22.7	0

Table 35: Test results SAR LTE FDD 5 850 MHz (see max. SAR plot on page 70.)

** - maximum possible output power declared by manufacturer

measured / extrapolated SAR numbers - Extremities - LTE FDD 12 700MHz - Limit for 10g: 4W/Kg										
Ch.	Freq. (MHz)	RB offset	Position	cond. P _{max} (dBm)		SAR _{10g} (W/kg)		power drift (dB)	liquid (°C)	dist. (mm)
				declared**	meas.	meas.	extrap.			
10MHz BW/1RB/QPSK - Move5000										
23060	704.0	25	top	24.0	23.3	0.110	0.129	0.00	22.7	0
23060	704.0	25	bottom	24.0	23.3	0.187	0.220	0.03	22.7	0
23060	704.0	25	left	24.0	23.3	0.319	0.375	-0.02	22.7	0
23095	707.5	25	left	24.0	23.2	0.312	0.375	0.01	22.7	0
23130	711.0	25	left	24.0	23.1	0.263	0.324	-0.14	22.7	0
23060	704.0	25	right	24.0	23.3	0.080	0.094	-0.17	22.7	0
23060	704.0	25	front	24.0	23.3	0.013	0.015	11.00	22.7	0
23060	704.0	25	rear	24.0	23.3	0.021	0.025	0.08	22.7	0
10MHz BW/25RB/QPSK - Move5000										
23060	704.0	12	top	23.0	22.2	0.103	0.124	0.07	22.7	0
23060	704.0	12	bottom	23.0	22.2	0.158	0.190	0.06	22.7	0
23060	704.0	12	left	23.0	22.2	0.311	0.374	-0.01	22.7	0
23060	704.0	12	right	23.0	22.2	0.067	0.080	0.01	22.7	0
23060	704.0	12	front	23.0	22.2	0.010	0.012	0.14	22.7	0
23060	704.0	12	rear	23.0	22.2	0.019	0.022	0.16	22.7	0
10MHz BW/1RB/QPSK - Move3500										
23060	704.0	25	left	24.0	23.3	0.247	0.290	0.03	22.7	0
23095	707.5	25	left	24.0	23.2	0.267	0.321	0.00	22.7	0
23130	711.0	25	left	24.0	23.1	0.273	0.336	-0.03	22.7	0

Table 36: Test results SAR LTE FDD 12 700 MHz (see max. plot on page 71.)

** - maximum possible output power declared by manufacturer

measured / extrapolated SAR numbers - Extremities - WLAN 2450 MHz - Limit for 10g: 4W/Kg											
Ch.	Freq. (MHz)	test cond.	Position	cond. P _{max} (dBm)		SAR _{10g} (W/kg)			power drift (dB)	liquid (°C)	dist. (mm)
				declared**	meas.	meas.	extrap.	100% DF			
Move5000											
1	2412	1Mbit/s	top	7.0	6.0	0.077	0.097	0.099	0.17	21.9	0
1	2412	1Mbit/s	bottom	7.0	5.4	0.013	0.018	0.019	-0.15	21.9	0
1	2412	1Mbit/s	left	7.0	6.0	0.129	0.162	0.166	-0.04	21.9	0
6	2437	1Mbit/s	left	7.0	5.4	0.125	0.181	0.184	-0.17	21.9	0
11	2462	1Mbit/s	left	7.0	5.6	0.124	0.171	0.175	-0.18	21.9	0
1	2412	1Mbit/s	right	7.0	6.0	0.002	0.003	0.003	0.17	21.9	0
1	2412	1Mbit/s	front	7.0	6.0	0.010	0.013	0.013	0.16	21.9	0
1	2412	1Mbit/s	rear	7.0	5.4	0.003	0.004	0.004	0.16	21.9	0
Move3500											
6	2437	1Mbit/s	left	7.0	5.4	0.148	0.214	0.218	0.15	21.9	0

Table 37: Test results body worn SAR WLAN 2.45 GHz (see max. SAR on page 72.)

measured / extrapolated SAR numbers - Extremities - Bluetooth 2450 MHz - Limit for 10g: 4W/Kg										
Ch.	Freq. (MHz)	Position	cond. P _{max} (dBm)		SAR _{10g} (W/kg)		power drift (dB)	liquid (°C)	dist. (mm)	
			declared**	measured	measured	extrap.				
Move5000										
0	2402	top	16.0	15.4	0.879	1.009	-0.01	21.9	0	
39	2441	top	16.0	15.4	0.888	1.020	-0.03	21.9	0	
78	2480	top	16.0	15.4	0.928	1.065	-0.04	21.9	0	
78	2480	bottom	16.0	15.4	0.175	0.201	0.19	21.9	0	
78	2480	left	16.0	15.4	0.028	0.032	0.11	21.9	0	
78	2480	right	16.0	15.4	0.751	0.862	0.16	21.9	0	
78	2480	front	16.0	15.4	0.311	0.357	-0.13	21.9	0	
78	2480	rear	16.0	15.4	0.017	0.019	0.12	21.9	0	
Move3500										
0	2402	top	16.0	15.4	0.882	1.013	-0.02	21.9	0	
39	2441	top	16.0	15.4	0.821	0.943	0.00	21.9	0	
78	2480	top	16.0	15.4	0.825	0.947	-0.03	21.9	0	
78	2480	bottom	16.0	15.4	0.142	0.163	-0.15	21.9	0	
78	2480	left	16.0	15.4	0.023	0.027	-0.18	21.9	0	
78	2480	right	16.0	15.4	0.745	0.855	0.18	21.9	0	
78	2480	front	16.0	15.4	0.231	0.265	-0.12	21.9	0	
78	2480	rear	16.0	15.4	0.019	0.022	0.13	21.9	0	

Table 38: Test results SAR Bluetooth 2.45 GHz (see max. SAR plot on page 73.)

** - maximum possible output power declared by manufacturer

Estimated stand alone SAR.					
Communication system	freq. (GHz)	distance (mm)	P _{avg} (dBm)	P _{avg} (mW)	estimated _{1-g} (W/kg)
WLAN5200	5.2	5	1	1.3	0.077
WLAN5300	5.3	5	1.5	1.4	0.087
WLAN5600	5.6	5	3	2.0	0.126
WLAN5800	5.8	5	3.5	2.2	0.144

Table 39: Estimated stand alone SAR_{max} for Bluetooth 2450MHz

7.2.3 Multiple Transmitter Information

The following tables list information which is relevant for the decision if a simultaneous transmit evaluation is necessary according to FCC KDB 447498D01 General RF Exposure Guidance v05.

reported SAR WWAN, BT and WLAN 2.4GHz, Σ SAR evaluation					
Frequency band	Position	SAR _{max} /W/kg			Σ SAR <4W/kg
		WWAN	BT	WLAN	
UMTS FDD II	top	0.195	1.065	0.099	1.359
	bottom	0.241	0.201	0.019	0.461
	left	2.813	0.032	0.218	3.063
	right	0.171	0.862	0.003	1.036
	front	0.088	0.357	0.011	0.456
	rear	0.118	0.022	0.004	0.144
UMTS FDD IV	top	0.151	1.065	0.099	1.315
	bottom	0.317	0.201	0.019	0.537
	left	2.597	0.032	0.218	2.847
	right	0.284	0.862	0.003	1.149
	front	0.047	0.357	0.011	0.415
	rear	0.102	0.022	0.004	0.128
UMTS FDD V	top	0.151	1.065	0.099	1.315
	bottom	0.317	0.201	0.019	0.537
	left	2.597	0.032	0.218	2.847
	right	0.271	0.862	0.003	1.136
	front	0.045	0.357	0.011	0.413
	rear	0.098	0.022	0.004	0.124
LTE FDD 2	top	0.235	1.065	0.099	1.399
	bottom	0.150	0.201	0.019	0.370
	left	0.631	0.032	0.218	0.881
	right	0.076	0.862	0.003	0.941
	front	0.034	0.357	0.011	0.402
	rear	0.038	0.022	0.004	0.064
LTE FDD 4	top	0.116	1.065	0.099	1.280
	bottom	0.349	0.201	0.019	0.569
	left	2.478	0.032	0.218	2.728
	right	0.263	0.862	0.003	1.128
	front	0.042	0.357	0.011	0.410
	rear	0.029	0.022	0.004	0.055
LTE FDD 5	top	0.267	1.065	0.099	1.431
	bottom	0.185	0.201	0.019	0.405
	left	0.706	0.032	0.218	0.956
	right	0.107	0.862	0.003	0.972
	front	0.009	0.357	0.011	0.377
	rear	0.039	0.022	0.004	0.065
LTE FDD 12	top	0.129	1.065	0.099	1.293
	bottom	0.220	0.201	0.019	0.440
	left	0.385	0.032	0.218	0.635
	right	0.094	0.862	0.003	0.959
	front	0.015	0.357	0.011	0.383
	rear	0.025	0.022	0.004	0.051

Table 40: SAR_{max} WWAN and WLAN 2.4GHz, Σ SAR_{10g} evaluation

reported SAR WWAN, BT and WLAN5GHz, Σ SAR evaluation					
Frequency band	Position	SAR _{max} /W/kg			Σ SAR <4W/kg
		WWAN	BT	WLAN	
UMTS FDD II	top	0.195	1.065	0.144	1.404
	bottom	0.241	0.201	0.144	0.586
	left	2.813	0.032	0.144	2.989
	right	0.171	0.862	0.144	1.177
	front	0.088	0.357	0.144	0.589
	rear	0.118	0.022	0.144	0.284
UMTS FDD IV	top	0.151	1.065	0.144	1.360
	bottom	0.317	0.201	0.144	0.662
	left	2.597	0.032	0.144	2.773
	right	0.284	0.862	0.144	1.290
	front	0.047	0.357	0.144	0.548
	rear	0.102	0.022	0.144	0.268
UMTS FDD V	top	0.151	1.065	0.144	1.360
	bottom	0.317	0.201	0.144	0.662
	left	2.597	0.032	0.144	2.773
	right	0.271	0.862	0.144	1.277
	front	0.045	0.357	0.144	0.546
	rear	0.098	0.022	0.144	0.264
LTE FDD 2	top	0.235	1.065	0.144	1.444
	bottom	0.150	0.201	0.144	0.495
	left	0.631	0.032	0.144	0.807
	right	0.076	0.862	0.144	1.082
	front	0.034	0.357	0.144	0.535
	rear	0.038	0.022	0.144	0.204
LTE FDD 4	top	0.116	1.065	0.144	1.325
	bottom	0.349	0.201	0.144	0.694
	left	2.478	0.032	0.144	2.654
	right	0.263	0.862	0.144	1.269
	front	0.042	0.357	0.144	0.543
	rear	0.029	0.022	0.144	0.195
LTE FDD 5	top	0.267	1.065	0.144	1.476
	bottom	0.185	0.201	0.144	0.530
	left	0.706	0.032	0.144	0.882
	right	0.107	0.862	0.144	1.113
	front	0.009	0.357	0.144	0.510
	rear	0.039	0.022	0.144	0.205
LTE FDD 12	top	0.129	1.065	0.144	1.338
	bottom	0.220	0.201	0.144	0.565
	left	0.385	0.032	0.144	0.561
	right	0.094	0.862	0.144	1.100
	front	0.015	0.357	0.144	0.516
	rear	0.025	0.022	0.144	0.191

Table 41: SAR_{max} WWAN and **WLAN 5GHz**, Σ SAR_{10g} evaluation

Conclusion:

Σ SAR < 4 W/kg therefore simultaneous transmissions SAR measurement with the enlarged zoom scan measurement and volume scan post-processing procedures is **not** required.

8 Test equipment and ancillaries used for tests

To simplify the identification of the test equipment and/or ancillaries which were used, the reporting of the relevant test cases only refer to the test item number as specified in the table below.

Equipment	Type	Manufacturer	Serial No.	Last Calibration	Frequency (months)
Dosimetric E-Field Probe	ES3DV3	Schmid & Partner Engineering AG	3320	January 15, 2018	12
Dosimetric E-Field Probe	EX3DV4	Schmid & Partner Engineering AG	3944	May 12, 2017	12
750 MHz System Validation Dipole	D750V3	Schmid & Partner Engineering AG	1041	January 16, 2017	36
835 MHz System Validation Dipole	D835V2	Schmid & Partner Engineering AG	4d153	May 11, 2017	36
1750 MHz System Validation Dipole	D1750V2	Schmid & Partner Engineering AG	1093	May 13, 2015	36
1900 MHz System Validation Dipole	D1900V2	Schmid & Partner Engineering AG	5d009	May 10, 2017	36
2450 MHz System Validation Dipole	D2450V2	Schmid & Partner Engineering AG	710	August 15, 2016	36
Data acquisition electronics	DAE3V1	Schmid & Partner Engineering AG	413	January 10, 2018	12
Data acquisition electronics	DAE3V1	Schmid & Partner Engineering AG	477	May 12, 2017	12
Software	DASY52 52.8.7	Schmid & Partner Engineering AG	---	N/A	--
SAM Twin Phantom V5.0	QD 000 P40 C	Schmid & Partner Engineering AG	1813	N/A	--
Universal Radio Communication Tester	CMU 200	Rohde & Schwarz	106826	January 05, 2018	24
Universal Radio Communication Tester	CMW500	Rohde & Schwarz	102375	January 11, 2018	24
Bluetooth Tester	CBT	Rohde & Schwarz	100313	September 22, 2016	24
Network Analyser 300 kHz to 6 GHz	8753ES	Agilent Technologies)*	US39174436	December 14, 2017	24
Dielectric Probe Kit	85070C	Hewlett Packard	US99360146	N/A	12
Signal Generator	8665A	Hewlett Packard	2833A00112	December 14, 2017	24
Signal Generator	8671B	Hewlett Packard	2823A00656	January 31, 2017	24
Amplifier	25S1G4 (25 Watt)	Amplifier Reasearch	20452	N/A	--
Power Meter	NRP	Rohde & Schwarz	101367	December 17, 2017	24
Power Meter Sensor	NRP Z22	Rohde & Schwarz	100227	December 10, 2017	12
Power Meter Sensor	NRP Z22	Rohde & Schwarz	100234	December 10, 2017	12
Directional Coupler	778D	Hewlett Packard	19171	December 10, 2017	12

)* : Network analyzer probe calibration against air, distilled water and a shorting block performed before measuring liquid parameters.

9 Observations

No observations exceeding those reported with the single test cases have been made.

Annex A: System performance check

Date/Time: 02.03.2018 14:23:33

SystemPerformanceCheck-D750 MSL 2018-03-02
DUT: Dipole 750 MHz; Type: D750V3; Serial: 1041

Communication System: UID 0, CW (0); Communication System Band: D750 (750.0 MHz); Frequency: 750 MHz; Communication System PAR: 0 dB; PMF: 1

 Medium parameters used: $f = 750$ MHz; $\sigma = 0.959$ S/m; $\epsilon_r = 55.078$; $\rho = 1000$ kg/m³

Phantom section: Flat Section

Measurement Standard: DASYS5

DASY5 Configuration:

- Probe: ES3DV3 - SN3320; ConvF(6.28, 6.28, 6.28); Calibrated: 15.01.2018;
- Sensor-Surface: 3mm (Mechanical Surface Detection), $z = 2.0, 32.0$
- Electronics: DAE3 Sn413; Calibrated: 10.01.2018
- Phantom: SAM front; Type: QD000P40CC; Serial: TP-1041
- DASY52 52.8.7(1137); SEMCAD X 14.6.10(7164)

MSL750/d=15mm, Pin=100 mW, dist=3mm/Area Scan (51x51x1): Interpolated grid: $dx=1.500$ mm, $dy=1.500$ mm

Maximum value of SAR (interpolated) = 0.963 W/kg

MSL750/d=15mm, Pin=100 mW, dist=3mm/Zoom Scan (7x7x7)/Cube 0:
Measurement grid: $dx=5$ mm, $dy=5$ mm, $dz=5$ mm

Reference Value = 32.712 V/m; Power Drift = -0.09 dB

Peak SAR (extrapolated) = 1.22 W/kg

SAR(1 g) = 0.832 W/kg; SAR(10 g) = 0.556 W/kg

Maximum value of SAR (measured) = 0.965 W/kg

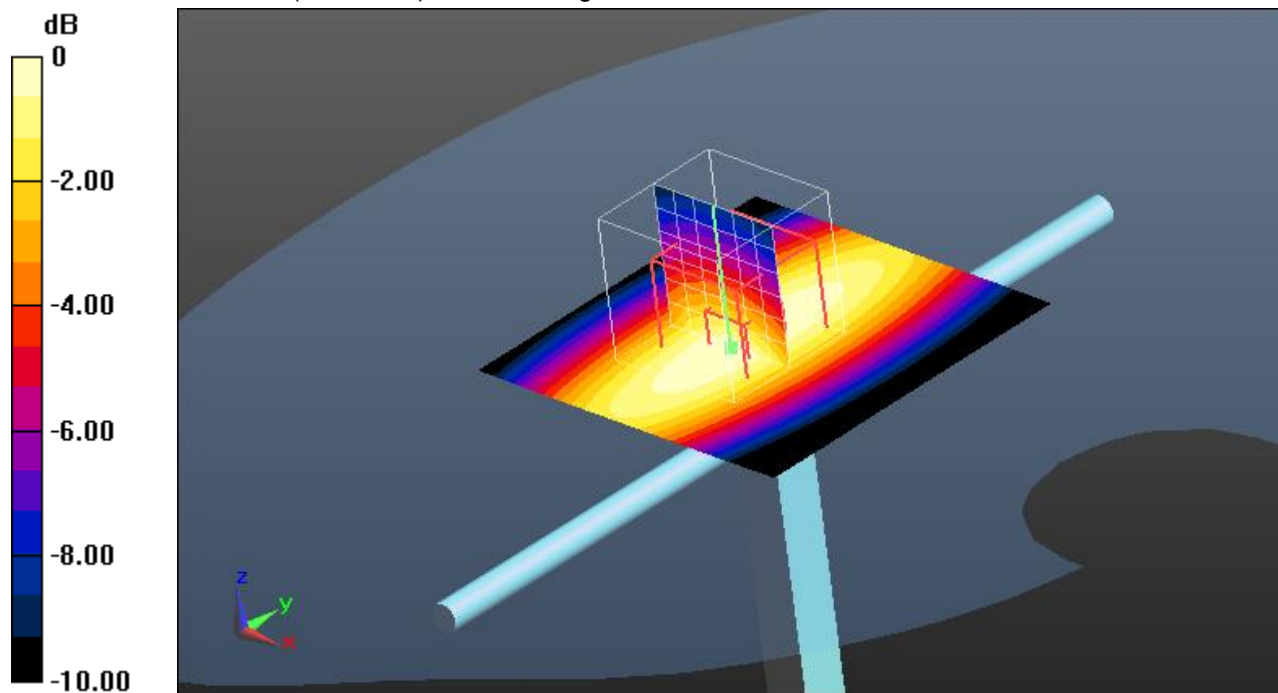

0 dB = 0.965 W/kg = -0.15 dBW/kg

Additional information:

ambient temperature: 23.8°C; liquid temperature: 22.7°C

SystemPerformanceCheck-D835 MSL 2018-03-15

DUT: Dipole 835 MHz; Type: D835V2; Serial: 4d153

Communication System: UID 0, CW (0); Communication System Band: D835 (835.0 MHz); Frequency: 835 MHz; Communication System PAR: 0 dB; PMF: 1

Medium parameters used: $f = 835$ MHz; $\sigma = 0.991$ S/m; $\epsilon_r = 54.923$; $\rho = 1000$ kg/m³

Phantom section: Flat Section

Measurement Standard: DASY5

DASY5 Configuration:

- Probe: ES3DV3 - SN3320; ConvF(6.16, 6.16, 6.16); Calibrated: 15.01.2018;
- Sensor-Surface: 3mm (Mechanical Surface Detection), $z = 2.0, 32.0$
- Electronics: DAE3 Sn413; Calibrated: 10.01.2018
- Phantom: SAM; Type: SAM; Serial: 1043
- DASY52 52.8.7(1137); SEMCAD X 14.6.10(7164)

MSL835/d=15mm, Pin=100 mW, dist=3.0mm/Area Scan (51x51x1): Interpolated

grid: $dx=1.500$ mm, $dy=1.500$ mm

Maximum value of SAR (interpolated) = 1.17 W/kg

MSL835/d=15mm, Pin=100 mW, dist=3.0mm/Zoom Scan (7x7x7)/Cube 0:

Measurement grid: $dx=5$ mm, $dy=5$ mm, $dz=5$ mm

Reference Value = 36.029 V/m; Power Drift = -0.09 dB

Peak SAR (extrapolated) = 1.50 W/kg

SAR(1 g) = 1.03 W/kg; SAR(10 g) = 0.682 W/kg

Maximum value of SAR (measured) = 1.20 W/kg

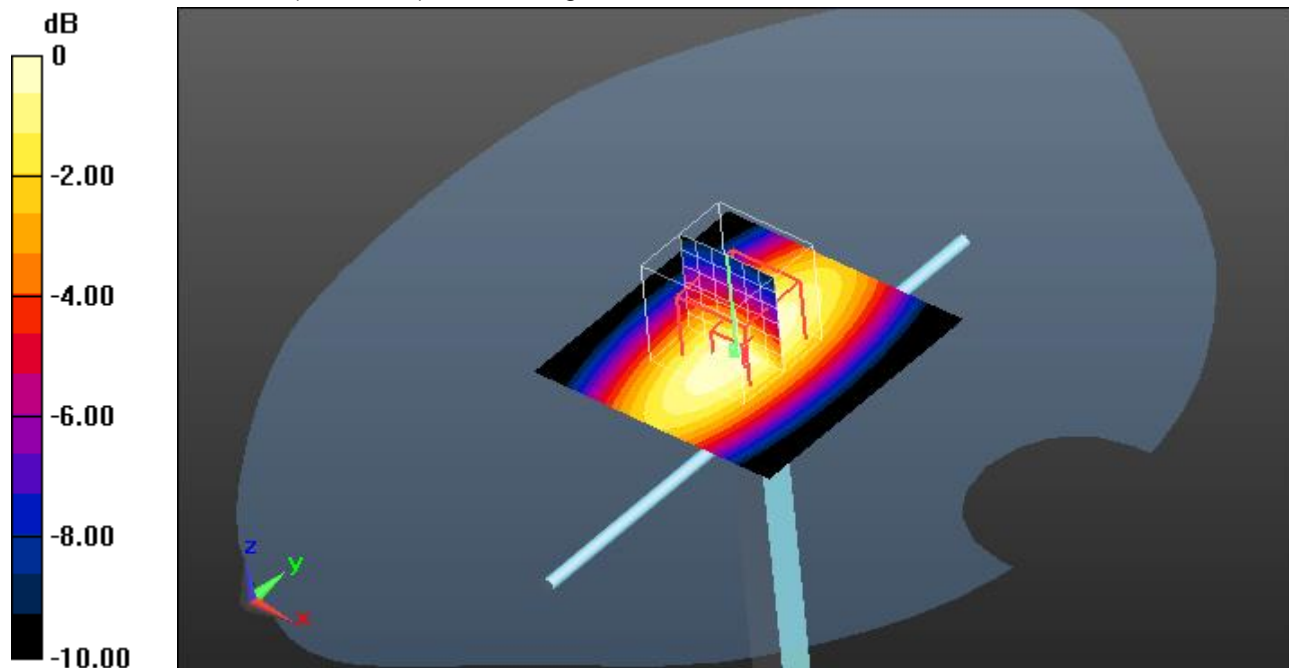

0 dB = 1.20 W/kg = 0.79 dBW/kg

Additional information:

ambient temperature: 23.6°C; liquid temperature: 22.7°C

SystemPerformanceCheck-D1750 MSL 2018-03-09

DUT: Dipole 1750 MHz; Type: D1750V2; Serial: 1093

Communication System: UID 0, CW (0); Communication System Band: D1750 (1750.0 MHz); Frequency: 1750 MHz; Communication System PAR: 0 dB; PMF: 1

Medium parameters used: $f = 1750$ MHz; $\sigma = 1.511$ S/m; $\epsilon_r = 52.762$; $\rho = 1000$ kg/m³

Phantom section: Flat Section

Measurement Standard: DASY5

DASY5 Configuration:

- Probe: ES3DV3 - SN3320; ConvF(4.97, 4.97, 4.97); Calibrated: 15.01.2018;
- Sensor-Surface: 3mm (Mechanical Surface Detection), $z = 2.0, 32.0$
- Electronics: DAE3 Sn413; Calibrated: 10.01.2018
- Phantom: SAM; Type: SAM; Serial: 1043
- DASY52 52.8.7(1137); SEMCAD X 14.6.10(7164)

MSL1750/d=10mm, Pin=100mW/Area Scan (51x51x1): Interpolated grid: $dx=1.500$ mm, $dy=1.500$ mm

Maximum value of SAR (interpolated) = 5.61 W/kg

MSL1750/d=10mm, Pin=100mW/Zoom Scan (7x7x7)/Cube 0: Measurement grid:

$dx=5$ mm, $dy=5$ mm, $dz=5$ mm

Reference Value = 58.110 V/m; Power Drift = -0.06 dB

Peak SAR (extrapolated) = 6.57 W/kg

SAR(1 g) = 3.72 W/kg; SAR(10 g) = 1.96 W/kg

Maximum value of SAR (measured) = 4.79 W/kg

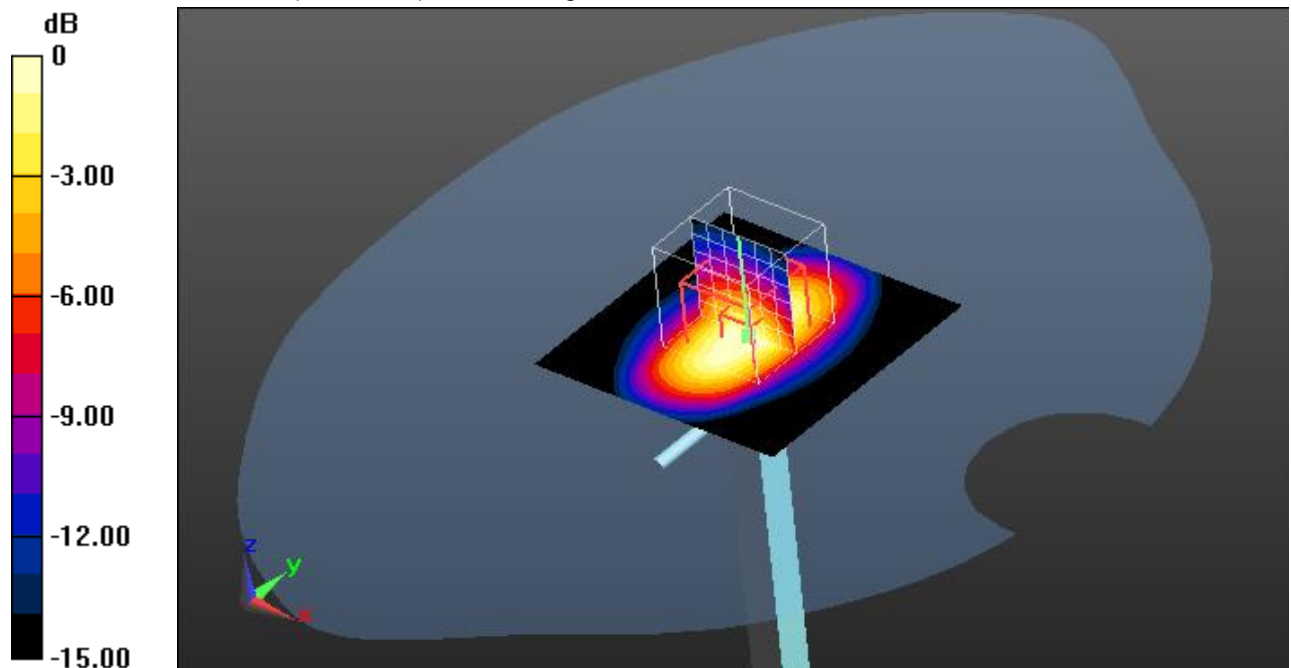

0 dB = 4.79 W/kg = 6.80 dBW/kg

Additional information:

ambient temperature: 22.6°C; liquid temperature: 20.4°C

SystemPerformanceCheck-D1900 MSL 2018-03-13

DUT: Dipole 1900 MHz; Type: D1900V2; Serial: 5d009

Communication System: UID 0, CW (0); Communication System Band: D1900 (1900.0 MHz); Frequency: 1900 MHz; Communication System PAR: 0 dB; PMF: 1

Medium parameters used: $f = 1900$ MHz; $\sigma = 1.518$ S/m; $\epsilon_r = 51.726$; $\rho = 1000$ kg/m³

Phantom section: Flat Section

Measurement Standard: DASY5

DASY5 Configuration:

- Probe: ES3DV3 - SN3320; ConvF(4.78, 4.78, 4.78); Calibrated: 15.01.2018;
- Sensor-Surface: 3mm (Mechanical Surface Detection), $z = 2.0, 32.0$
- Electronics: DAE3 Sn413; Calibrated: 10.01.2018
- Phantom: SAM; Type: SAM; Serial: 1043
- DASY52 52.8.7(1137); SEMCAD X 14.6.10(7164)

MSL1900/d=10mm, Pin=100mW/Area Scan (51x51x1): Interpolated grid: $dx=1.500$ mm, $dy=1.500$ mm

Maximum value of SAR (interpolated) = 5.88 W/kg

MSL1900/d=10mm, Pin=100mW/Zoom Scan (7x7x7)/Cube 0: Measurement grid:

$dx=5$ mm, $dy=5$ mm, $dz=5$ mm

Reference Value = 59.384 V/m; Power Drift = -0.01 dB

Peak SAR (extrapolated) = 6.64 W/kg

SAR(1 g) = 3.86 W/kg; SAR(10 g) = 2.05 W/kg

Maximum value of SAR (measured) = 4.86 W/kg

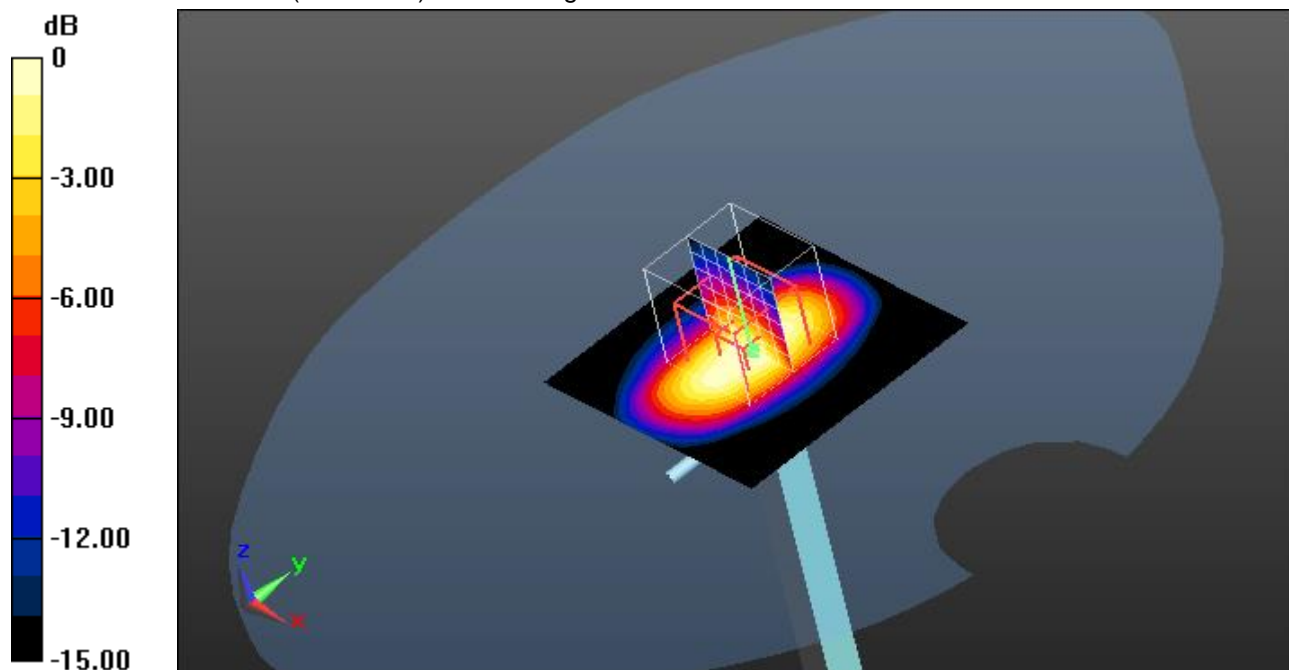

0 dB = 4.86 W/kg = 6.87 dBW/kg

Additional information:

ambient temperature: 22.8°C; liquid temperature: 21.7°C

SystemPerformanceCheck-D2450 MSL 2018-03-14

DUT: Dipole 2450 MHz; Type: D2450V2; Serial: 710

Communication System: UID 0, CW (0); Communication System Band: D2450 (2450.0 MHz); Frequency: 2450 MHz; Communication System PAR: 0 dB; PMF: 1

Medium parameters used: $f = 2450$ MHz; $\sigma = 1.987$ S/m; $\epsilon_r = 50.662$; $\rho = 1000$ kg/m³

Phantom section: Flat Section

Measurement Standard: DASY5

DASY5 Configuration:

- Probe: EX3DV4 - SN3944; ConvF(7.86, 7.86, 7.86); Calibrated: 12.05.2017;
- Sensor-Surface: 1.4mm (Mechanical Surface Detection), $z = 1.0, 31.0$
- Electronics: DAE3 Sn477; Calibrated: 12.05.2017
- Phantom: SAM front; Type: QD000P40CC; Serial: TP-1041
- DASY52 52.8.7(1137); SEMCAD X 14.6.10(7164)

MSL2450/d=10mm, Pin=100 mW, dist=1.4mm/Area Scan (51x51x1):

Interpolated grid: $dx=1.500$ mm, $dy=1.500$ mm

Maximum value of SAR (interpolated) = 10.0 W/kg

MSL2450/d=10mm, Pin=100 mW, dist=1.4mm/Zoom Scan (7x7x7)/Cube 0:

Measurement grid: $dx=5$ mm, $dy=5$ mm, $dz=5$ mm

Reference Value = 67.235 V/m; Power Drift = -0.13 dB

Peak SAR (extrapolated) = 10.2 W/kg

SAR(1 g) = 5.03 W/kg; SAR(10 g) = 2.34 W/kg

Maximum value of SAR (measured) = 8.26 W/kg

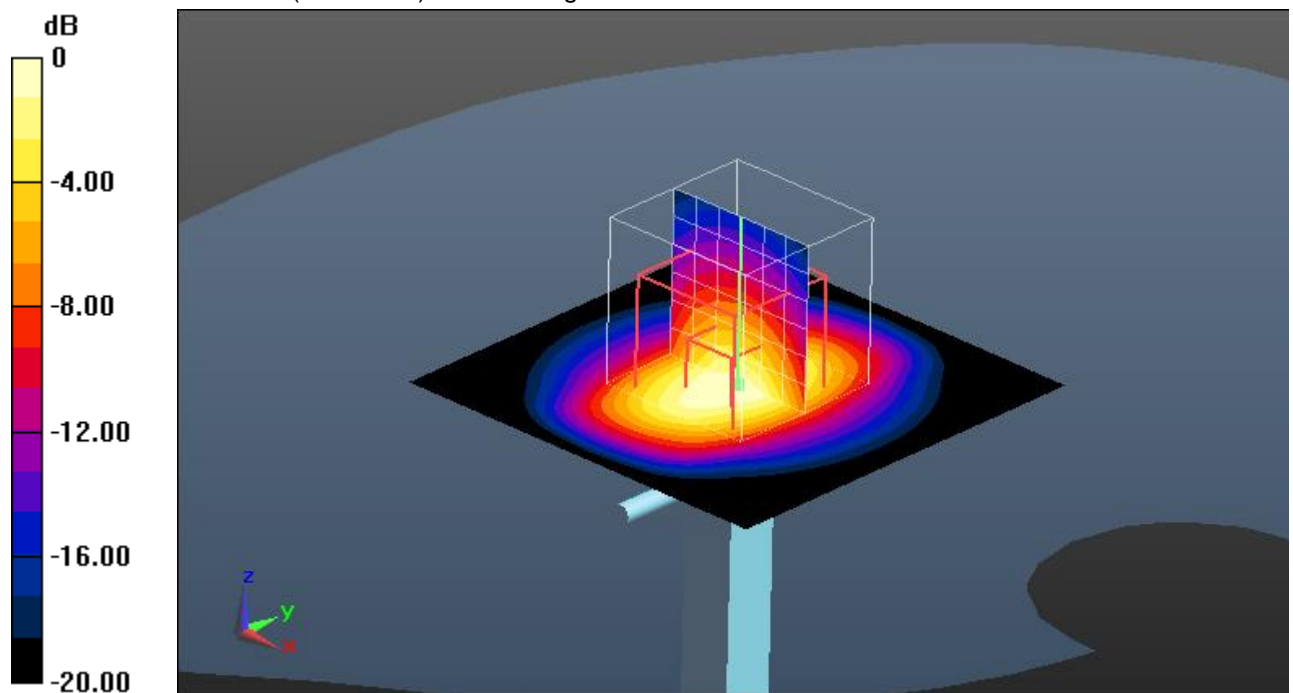

0 dB = 8.26 W/kg = 9.17 dBW/kg

Additional information:

ambient temperature: 23.8°C; liquid temperature: 21.9°C

Annex B: DASY5 measurement results

SAR plots for the highest measured SAR in each exposure configuration, wireless mode and frequency band combination according to FCC KDB 865664 D02

Date/Time: 13.03.2018 11:40:48

FCC_IEC-62209-2_UMTS FDD II Move3500

DUT: Ingenico; Type: Move/3500 CL/4G/WiFi/BT; Serial: 180317303201094402300908

Communication System: UID 0, UMTS FDD (0); Communication System Band: UMTS FDD II; Frequency: 1852.4 MHz; Communication System PAR: 0 dB; PMF: 1

Medium parameters used (interpolated): $f = 1852.4$ MHz; $\sigma = 1.471$ S/m; $\epsilon_r = 51.928$; $\rho = 1000$ kg/m³

Phantom section: Flat Section

Measurement Standard: DASY5

DASY5 Configuration:

- Probe: ES3DV3 - SN3320; ConvF(4.78, 4.78, 4.78); Calibrated: 15.01.2018;
- Sensor-Surface: 3mm (Mechanical Surface Detection (Locations From Previous Scan Used)), Sensor-Surface: 3mm (Mechanical Surface Detection), $z = 2.0, 27.0$
- Electronics: DAE3 Sn413; Calibrated: 10.01.2018
- Phantom: SAM; Type: SAM; Serial: 1043
- DASY52 52.8.7(1137); SEMCAD X 14.6.10(7164)

MSL 1900/Left position - Low/Area Scan (81x151x1): Interpolated grid: $dx=1.500$ mm, $dy=1.500$ mm

Maximum value of SAR (interpolated) = 7.09 W/kg

MSL 1900/Left position - Low/Zoom Scan (5x5x7)/Cube 0: Measurement grid:

$dx=7.5$ mm, $dy=7.5$ mm, $dz=5$ mm

Reference Value = 67.157 V/m; Power Drift = -0.01 dB

Peak SAR (extrapolated) = 9.21 W/kg

SAR(10 g) = 2.34 W/kg

Maximum value of SAR (measured) = 6.72 W/kg

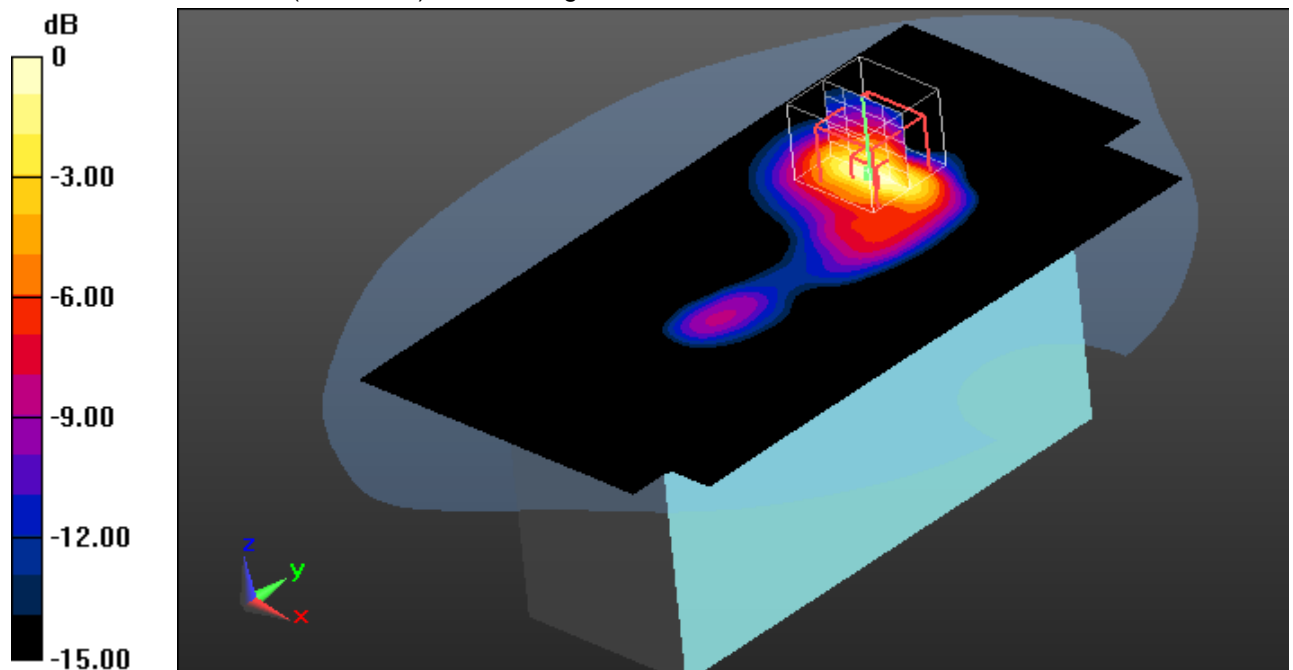

0 dB = 6.72 W/kg = 8.27 dBW/kg

Additional information:

position or distance of DUT to SAM: 0 mm

ambient temperature: 22.8°C; liquid temperature: 21.7°C

FCC_IEC-62209-2_UMTS FDD IV

DUT: Ingenico; Type: Move/5000 CL/4G/WiFi/BT; Serial: 180317303201083402304887

Communication System: UID 0, UMTS FDD (0); Communication System Band: UMTS FDD IV; Frequency: 1732.4 MHz; Communication System PAR: 0 dB; PMF: 1

Medium parameters used (interpolated): $f = 1732.4$ MHz; $\sigma = 1.491$ S/m; $\epsilon_r = 52.783$; $\rho = 1000$ kg/m³

Phantom section: Flat Section

Measurement Standard: DASY5

DASY5 Configuration:

- Probe: ES3DV3 - SN3320; ConvF(4.97, 4.97, 4.97); Calibrated: 15.01.2018;
- Sensor-Surface: 3mm (Mechanical Surface Detection (Locations From Previous Scan Used)), Sensor-Surface: 3mm (Mechanical Surface Detection), $z = 2.0, 27.0$
- Electronics: DAE3 Sn413; Calibrated: 10.01.2018
- Phantom: SAM; Type: SAM; Serial: 1043
- DASY52 52.8.7(1137); SEMCAD X 14.6.10(7164)

MSL 1750/Left position - Middle (WC)/Area Scan (81x151x1): Interpolated grid:

$dx=1.500$ mm, $dy=1.500$ mm

Maximum value of SAR (interpolated) = 8.80 W/kg

MSL 1750/Left position - Middle (WC)/Zoom Scan (6x6x7)/Cube 0: Measurement

grid: $dx=7.5$ mm, $dy=7.5$ mm, $dz=5$ mm

Reference Value = 75.681 V/m; Power Drift = -0.04 dB

Peak SAR (extrapolated) = 11.9 W/kg

SAR(10 g) = 2.48 W/kg

Maximum value of SAR (measured) = 7.86 W/kg

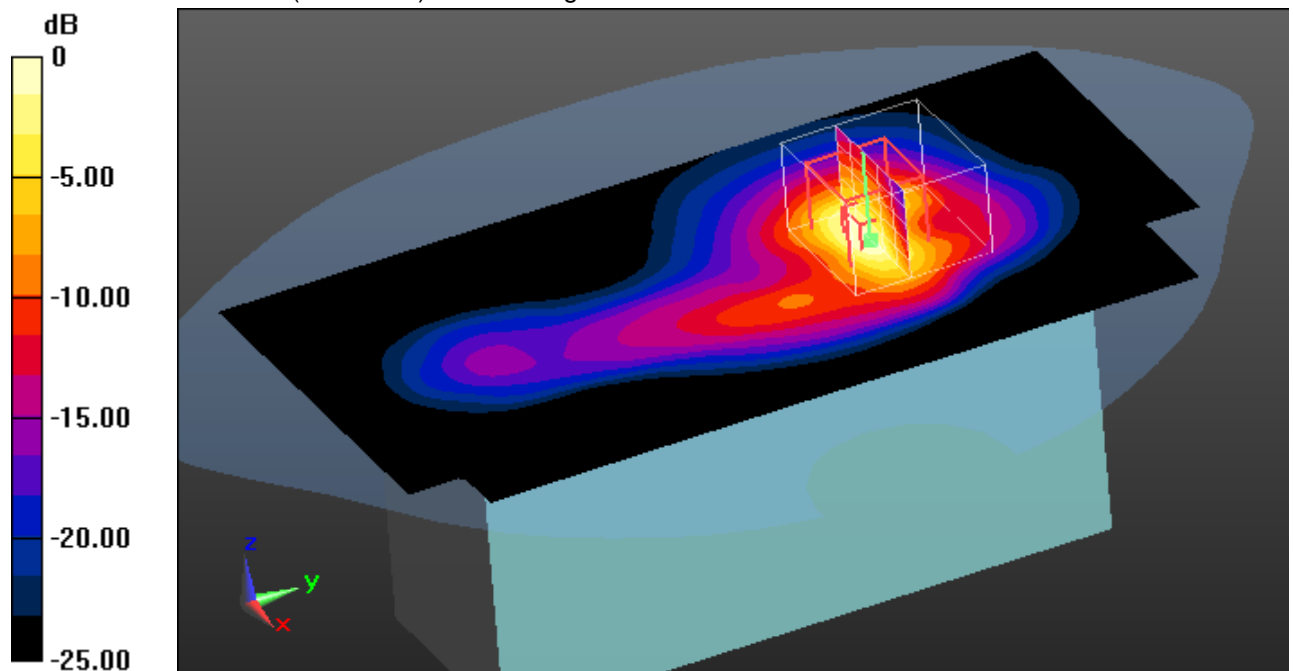

0 dB = 7.86 W/kg = 8.95 dBW/kg

Additional information:

position or distance of DUT to SAM: 0 mm

ambient temperature: 21.8°C; liquid temperature: 20.9°C

FCC_IEC-62209-2_UMTS FDD V Move3500

DUT: Ingenico; Type: Move/3500 CL/4G/WiFi/BT; Serial: 180317303201094402300908

Communication System: UID 0, UMTS FDD (0); Communication System Band: UMTS FDD V; Frequency: 826.4 MHz; Communication System PAR: 0 dB; PMF: 1

Medium parameters used (interpolated): $f = 826.4$ MHz; $\sigma = 0.981$ S/m; $\epsilon_r = 55.053$; $\rho = 1000$ kg/m³

Phantom section: Flat Section

Measurement Standard: DASY5

DASY5 Configuration:

- Probe: ES3DV3 - SN3320; ConvF(6.16, 6.16, 6.16); Calibrated: 15.01.2018;
- Sensor-Surface: 3mm (Mechanical Surface Detection), $z = 2.0, 27.0$
- Electronics: DAE3 Sn413; Calibrated: 10.01.2018
- Phantom: SAM; Type: SAM; Serial: 1043
- DASY52 52.8.7(1137); SEMCAD X 14.6.10(7164)

MSL 900/Left position - Low/Area Scan (81x151x1): Interpolated grid: $dx=1.500$ mm, $dy=1.500$ mm

Maximum value of SAR (interpolated) = 1.66 W/kg

MSL 900/Left position - Low/Zoom Scan (5x5x7)/Cube 0: Measurement grid:

$dx=7.5$ mm, $dy=7.5$ mm, $dz=5$ mm

Reference Value = 40.868 V/m; Power Drift = -0.16 dB

Peak SAR (extrapolated) = 2.53 W/kg

SAR(10 g) = 0.537 W/kg

Maximum value of SAR (measured) = 1.52 W/kg

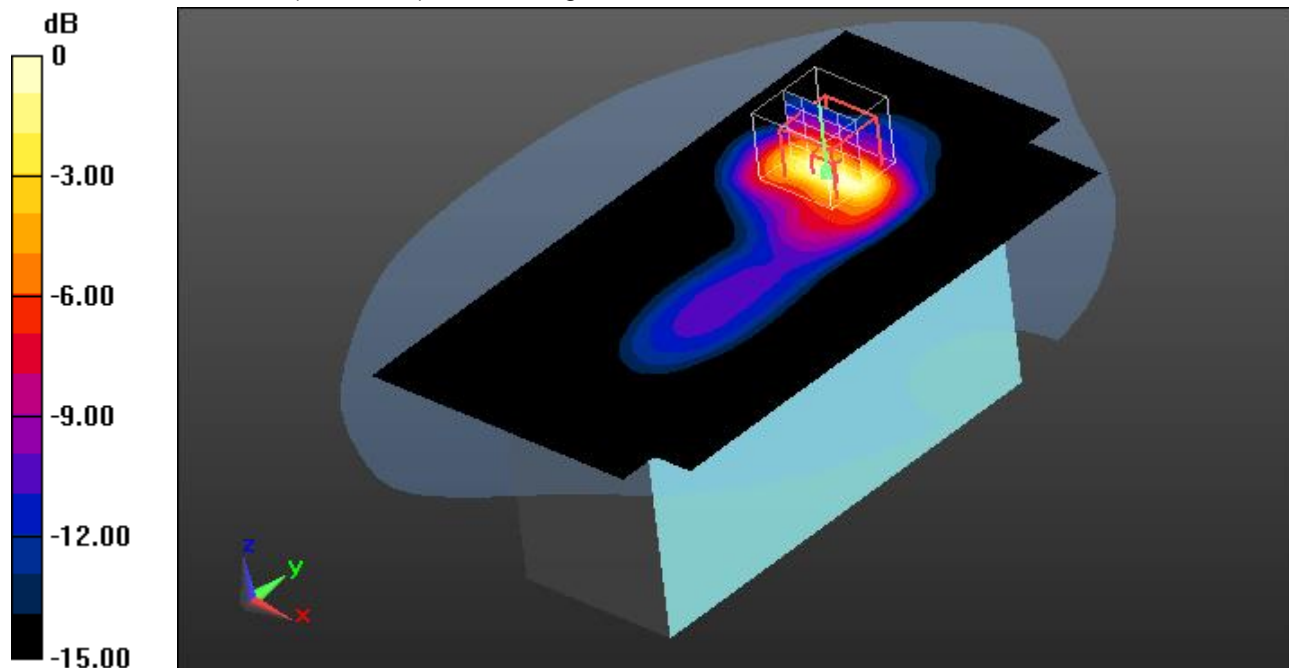

0 dB = 1.52 W/kg = 1.82 dBW/kg

Additional information:

position or distance of DUT to SAM: 0 mm

ambient temperature: 23.8°C; liquid temperature: 22.7°C

FCC_IEC-62209-2_LTE FDD 2 Move3500

DUT: Ingenico; Type: Move/3500 CL/4G/WiFi/BT; Serial: 180317303201094402300908

Communication System: UID 0, LTE FDD (0); Communication System Band: LTE 2 (1900MHz); Frequency: 1860 MHz; Communication System PAR: 0 dB; PMF: 1

Medium parameters used: $f = 1860$ MHz; $\sigma = 1.475$ S/m; $\epsilon_r = 51.853$; $\rho = 1000$ kg/m³

Phantom section: Flat Section

Measurement Standard: DASYS5

DASY5 Configuration:

- Probe: ES3DV3 - SN3320; ConvF(4.78, 4.78, 4.78); Calibrated: 15.01.2018;
- Sensor-Surface: 3mm (Mechanical Surface Detection (Locations From Previous Scan Used)), Sensor-Surface: 3mm (Mechanical Surface Detection), $z = 2.0, 27.0$
- Electronics: DAE3 Sn413; Calibrated: 10.01.2018
- Phantom: SAM; Type: SAM; Serial: 1043
- DASY52 52.8.7(1137); SEMCAD X 14.6.10(7164)

MSL 1900 - 20MHz BW - 1 RB - 0RB offset/Left position - Low wc/Area Scan

(81x151x1): Interpolated grid: $dx=1.500$ mm, $dy=1.500$ mm

Maximum value of SAR (interpolated) = 3.89 W/kg

MSL 1900 - 20MHz BW - 1 RB - 0RB offset/Left position - Low wc/Zoom

Scan (5x5x7)/Cube 0: Measurement grid: $dx=7.5$ mm, $dy=7.5$ mm, $dz=5$ mm

Reference Value = 53.775 V/m; Power Drift = -0.04 dB

Peak SAR (extrapolated) = 9.00 W/kg

SAR(10 g) = 2.08 W/kg

Maximum value of SAR (measured) = 5.42 W/kg

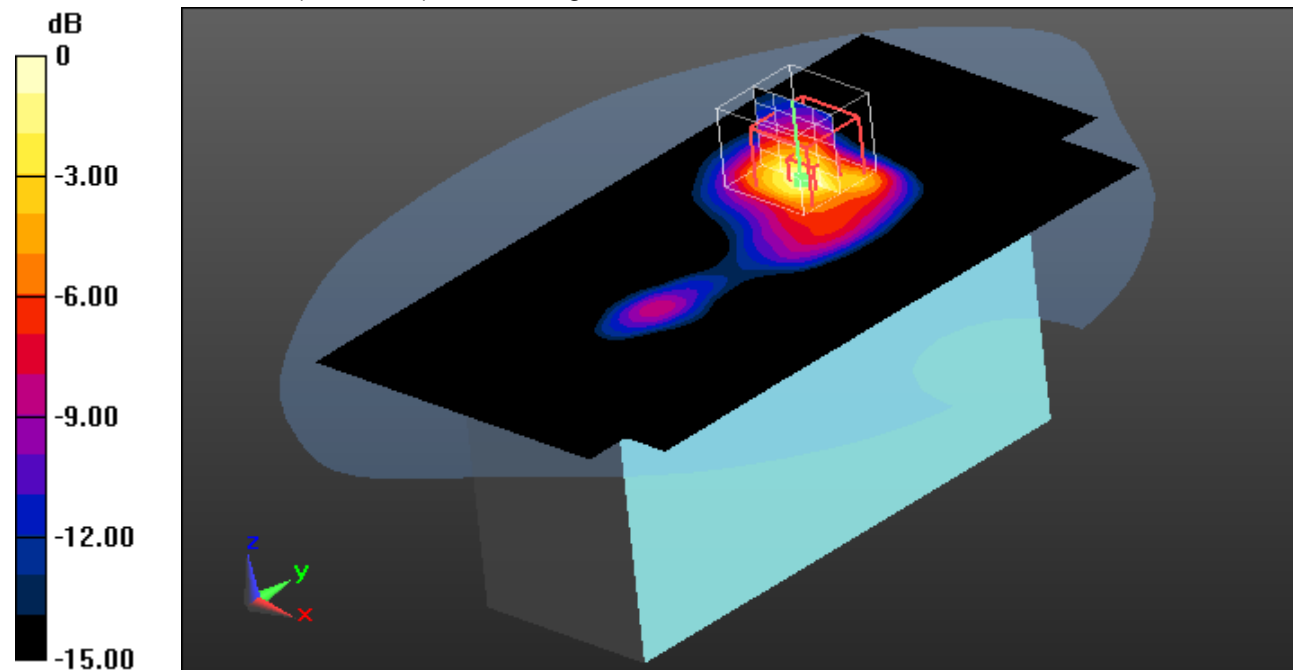

0 dB = 5.42 W/kg = 7.34 dBW/kg

Additional information:

position or distance of DUT to SAM: 0 mm

ambient temperature: 22.8°C; liquid temperature: 21.7°C

FCC_IEC-62209-2_LTE FDD 4

DUT: Ingenico; Type: Move/5000 CL/4G/WiFi/BT; Serial: 180317303201083402304887

Communication System: UID 0, LTE FDD (0); Communication System Band: LTE 4 (1700MHz); Frequency: 1745 MHz; Communication System PAR: 0 dB; PMF: 1

Medium parameters used: $f = 1745$ MHz; $\sigma = 1.505$ S/m; $\epsilon_r = 52.77$; $\rho = 1000$ kg/m³

Phantom section: Flat Section

Measurement Standard: DASY5

DASY5 Configuration:

- Probe: ES3DV3 - SN3320; ConvF(4.97, 4.97, 4.97); Calibrated: 15.01.2018;
- Sensor-Surface: 3mm (Mechanical Surface Detection (Locations From Previous Scan Used)), Sensor-Surface: 3mm (Mechanical Surface Detection), $z = 2.0, 27.0$
- Electronics: DAE3 Sn413; Calibrated: 10.01.2018
- Phantom: SAM; Type: SAM; Serial: 1043
- DASY52 52.8.7(1137); SEMCAD X 14.6.10(7164)

MSL 1750 - 20MHz BW - 1 RB - 0RB offset/Left position - High/Area Scan

(81x151x1): Interpolated grid: $dx=1.500$ mm, $dy=1.500$ mm

Maximum value of SAR (interpolated) = 6.88 W/kg

MSL 1750 - 20MHz BW - 1 RB - 0RB offset/Left position - High/Zoom Scan

(5x5x7)/Cube 0: Measurement grid: $dx=7.5$ mm, $dy=7.5$ mm, $dz=5$ mm

Reference Value = 72.582 V/m; Power Drift = -0.03 dB

Peak SAR (extrapolated) = 10.6 W/kg

SAR(10 g) = 2.26 W/kg

Maximum value of SAR (measured) = 7.44 W/kg

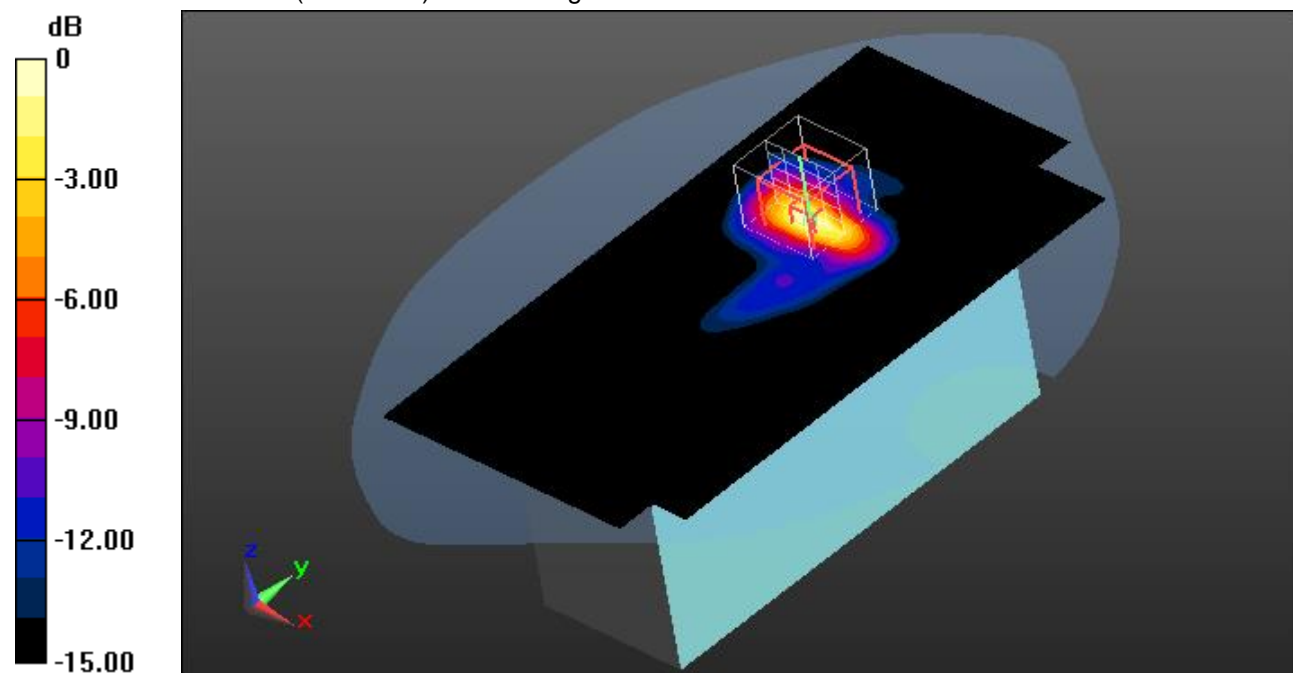

0 dB = 7.44 W/kg = 8.72 dBW/kg

Additional information:

position or distance of DUT to SAM: 0 mm

ambient temperature: 22.3°C; liquid temperature: 20.8°C

FCC_IEC-62209-2_LTE FDD 5 Move3500

DUT: Ingenico; Type: Move/3500 CL/4G/WiFi/BT; Serial: 180317303201094402300908

Communication System: UID 0, LTE FDD (0); Communication System Band: LTE 5 (850MHz); Frequency: 829 MHz; Communication System PAR: 0 dB; PMF: 1

Medium parameters used: $f = 829$ MHz; $\sigma = 0.984$ S/m; $\epsilon_r = 55.016$; $\rho = 1000$ kg/m³

Phantom section: Flat Section

Measurement Standard: DASYS5

DASY5 Configuration:

- Probe: ES3DV3 - SN3320; ConvF(6.16, 6.16, 6.16); Calibrated: 15.01.2018;
- Sensor-Surface: 3mm (Mechanical Surface Detection), $z = 2.0, 27.0$
- Electronics: DAE3 Sn413; Calibrated: 10.01.2018
- Phantom: SAM; Type: SAM; Serial: 1043
- DASY52 52.8.7(1137); SEMCAD X 14.6.10(7164)

MSL 900 - 10MHz BW - 1 RB - 0RB offset/Left position - Low/Area Scan

(81x151x1): Interpolated grid: $dx=1.500$ mm, $dy=1.500$ mm

Maximum value of SAR (interpolated) = 1.51 W/kg

MSL 900 - 10MHz BW - 1 RB - 0RB offset/Left position - Low/Zoom Scan

(6x5x7)/Cube 0: Measurement grid: $dx=7.5$ mm, $dy=7.5$ mm, $dz=5$ mm

Reference Value = 38.723 V/m; Power Drift = -0.09 dB

Peak SAR (extrapolated) = 2.72 W/kg

SAR(10 g) = 0.574 W/kg

Maximum value of SAR (measured) = 1.58 W/kg

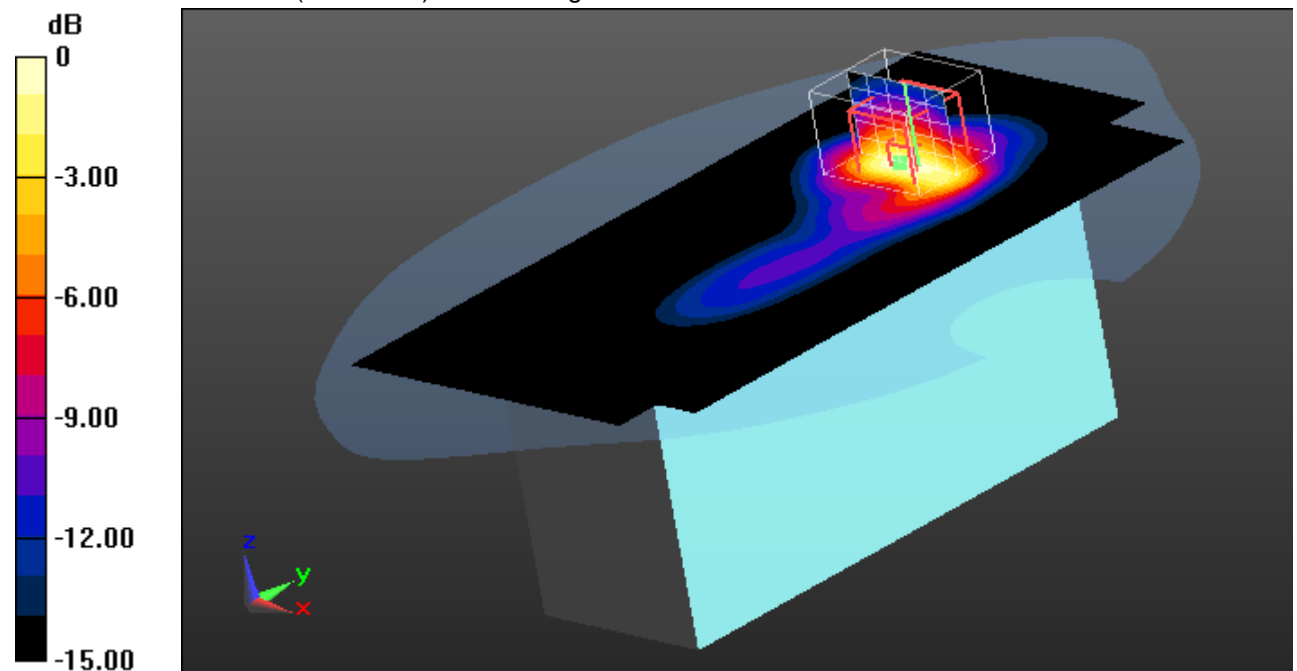

0 dB = 1.58 W/kg = 1.99 dBW/kg

Additional information:

position or distance of DUT to SAM: 0 mm

ambient temperature: 23.6°C; liquid temperature: 22.7°C

FCC_IEC-62209-2_LTE FDD 12

DUT: Ingenico; Type: Move/5000 CL/4G/WiFi/BT; Serial: 180317303201083402304887

Communication System: UID 0, LTE FDD (0); Communication System Band: LTE 12 (700MHz); Frequency: 704 MHz; Communication System PAR: 0 dB; PMF: 1

Medium parameters used: $f = 704$ MHz; $\sigma = 0.915$ S/m; $\epsilon_r = 55.545$; $\rho = 1000$ kg/m³

Phantom section: Flat Section

Measurement Standard: DASY5

DASY5 Configuration:

- Probe: ES3DV3 - SN3320; ConvF(6.28, 6.28, 6.28); Calibrated: 15.01.2018;
- Sensor-Surface: 3mm (Mechanical Surface Detection (Locations From Previous Scan Used)), Sensor-Surface: 3mm (Mechanical Surface Detection), $z = 2.0, 27.0$
- Electronics: DAE3 Sn413; Calibrated: 10.01.2018
- Phantom: SAM front; Type: QD000P40CC; Serial: TP-1041
- DASY52 52.8.7(1137); SEMCAD X 14.6.10(7164)

HSL 750 - 10MHz BW - 1 RB - 25RB offset/Left position - Low/Area Scan

(81x151x1): Interpolated grid: $dx=1.500$ mm, $dy=1.500$ mm

Maximum value of SAR (interpolated) = 0.846 W/kg

HSL 750 - 10MHz BW - 1 RB - 25RB offset/Left position - Low/Zoom Scan

(6x6x7)/Cube 0: Measurement grid: $dx=7.5$ mm, $dy=7.5$ mm, $dz=5$ mm

Reference Value = 20.221 V/m; Power Drift = -0.02 dB

Peak SAR (extrapolated) = 1.38 W/kg

SAR(10 g) = 0.319 W/kg

Maximum value of SAR (measured) = 0.847 W/kg

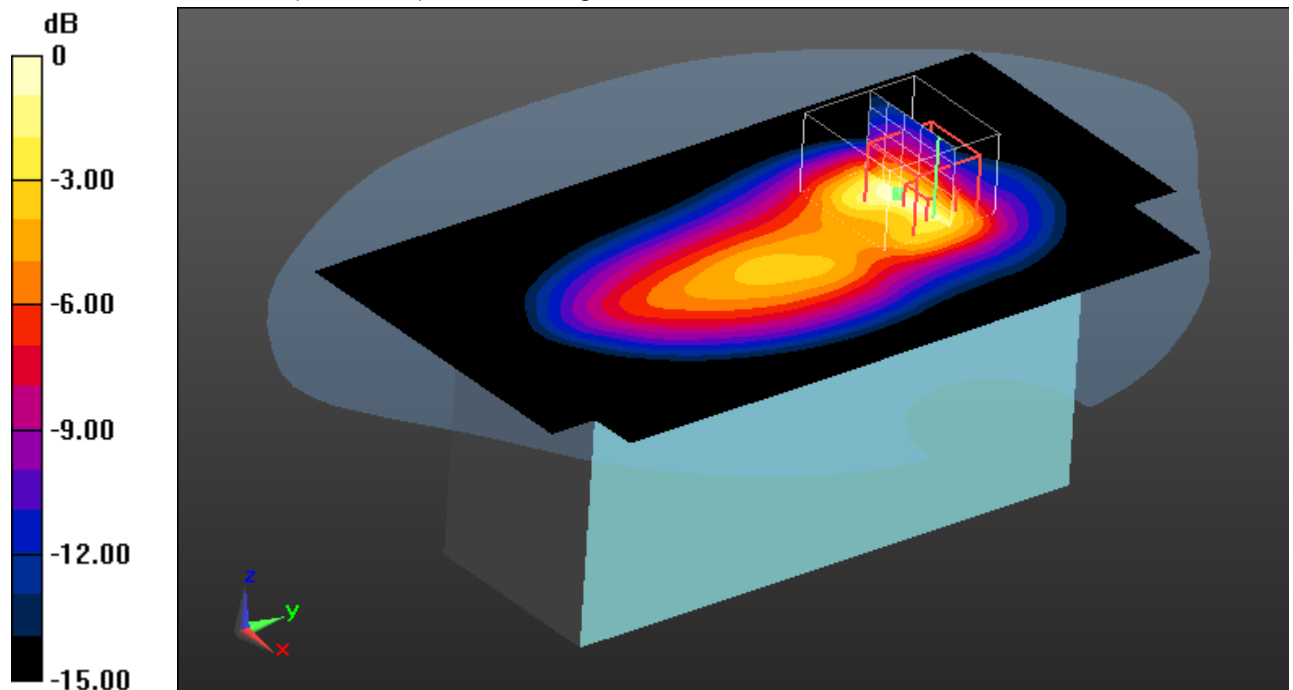

0 dB = 0.847 W/kg = -0.72 dBW/kg

Additional information:

position or distance of DUT to the phantom: 0 mm

ambient temperature: 23.8°C; liquid temperature: 22.7°C

FCC_IEC-62209-2_WLAN 2450

DUT: Ingenico; Type: Move/3500 CL/4G/WiFi/BT; Serial: 180317303201094402300908

Communication System: UID 0, WLAN 2450 (0); Communication System Band: 2.4 GHz; Frequency: 2437 MHz; Communication System PAR: 0 dB; PMF: 1

Medium parameters used: $f = 2437$ MHz; $\sigma = 1.973$ S/m; $\epsilon_r = 50.691$; $\rho = 1000$ kg/m³

Phantom section: Flat Section

Measurement Standard: DASY5

DASY5 Configuration:

- Probe: EX3DV4 - SN3944; ConvF(7.86, 7.86, 7.86); Calibrated: 12.05.2017;
- Sensor-Surface: 1.4mm (Mechanical Surface Detection (Locations From Previous Scan Used)), Sensor-Surface: 1.4mm (Mechanical Surface Detection), $z = 1.0, 26.0$
- Electronics: DAE3 Sn477; Calibrated: 12.05.2017
- Phantom: SAM front; Type: QD000P40CC; Serial: TP-1041
- DASY52 52.8.7(1137); SEMCAD X 14.6.10(7164)

MSL 2450 _ move 3500/Left position - Middle/Area Scan (81x151x1):

Interpolated grid: $dx=1.500$ mm, $dy=1.500$ mm

Maximum value of SAR (interpolated) = 0.482 W/kg

MSL 2450 _ move 3500/Left position - Middle/Zoom Scan (8x8x7)/Cube 0:

Measurement grid: $dx=5$ mm, $dy=5$ mm, $dz=5$ mm

Reference Value = 15.549 V/m; Power Drift = -0.17 dB

Peak SAR (extrapolated) = 1.06 W/kg

SAR(10 g) = 0.148 W/kg

Maximum value of SAR (measured) = 0.720 W/kg

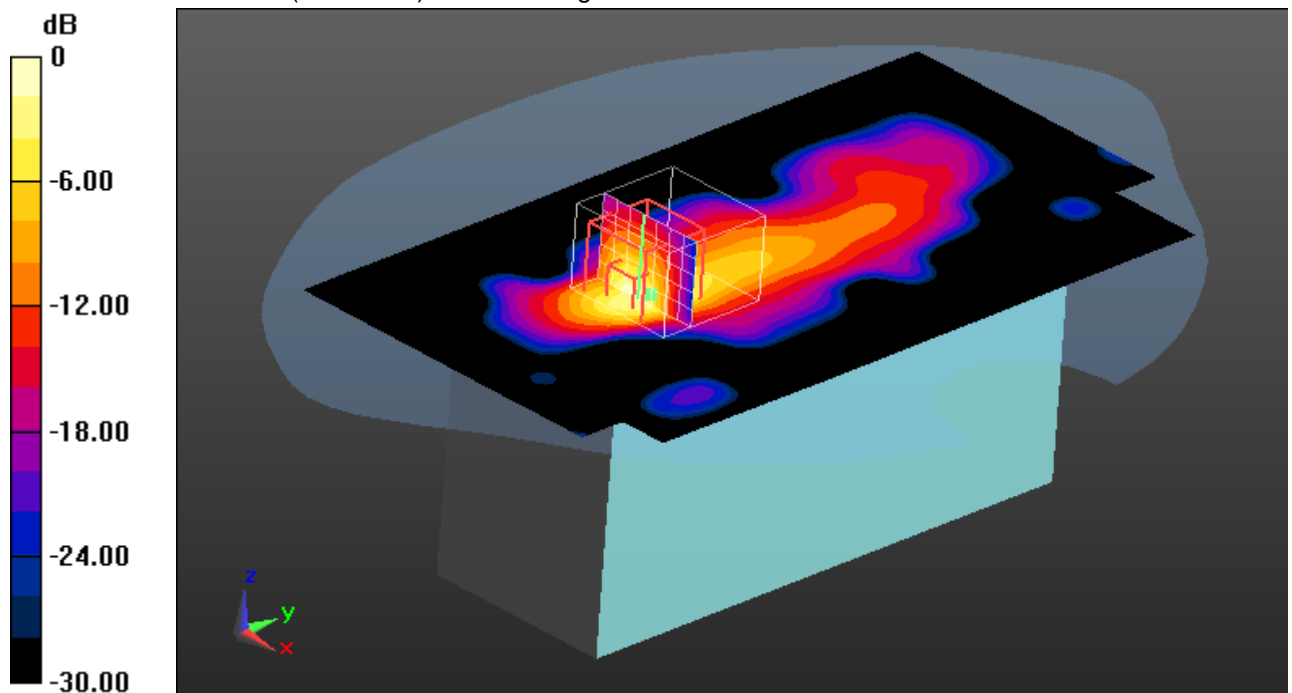

0 dB = 0.720 W/kg = -1.43 dBW/kg

Additional information:

position or distance of DUT to the phantom: 0 mm

ambient temperature: 23.8°C; liquid temperature: 21.9°C

FCC_IEC-62209-2_BT

DUT: Ingenico; Type: Move/5000 CL/4G/WiFi/BT; Serial: 180317303201083402304879

Communication System: UID 0, Bluetooth (0); Communication System Band: BT; Frequency: 2480 MHz;

Communication System PAR: 1.16 dB; PMF: 1.14288

Medium parameters used: $f = 2480$ MHz; $\sigma = 2.028$ S/m; $\epsilon_r = 50.541$; $\rho = 1000$ kg/m³

Phantom section: Flat Section

Measurement Standard: DASYS5

DASY5 Configuration:

- Probe: EX3DV4 - SN3944; ConvF(7.86, 7.86, 7.86); Calibrated: 12.05.2017;
- Sensor-Surface: 1.4mm (Mechanical Surface Detection (Locations From Previous Scan Used)), Sensor-Surface: 3mm (Mechanical Surface Detection), $z = 1.0, 26.0$
- Electronics: DAE3 Sn477; Calibrated: 12.05.2017
- Phantom: SAM front; Type: QD000P40CC; Serial: TP-1041
- DASY52 52.8.7(1137); SEMCAD X 14.6.10(7164)

MSL 2450_move 5000/Top position - High/Area Scan (81x151x1): Interpolated

grid: $dx=1.500$ mm, $dy=1.500$ mm

Maximum value of SAR (interpolated) = 2.84 W/kg

MSL 2450_move 5000/Top position - High/Zoom Scan (8x8x7)/Cube 0:

Measurement grid: $dx=5$ mm, $dy=5$ mm, $dz=5$ mm

Reference Value = 33.866 V/m; Power Drift = -0.04 dB

Peak SAR (extrapolated) = 4.05 W/kg

SAR(10 g) = 0.928 W/kg

Maximum value of SAR (measured) = 2.45 W/kg

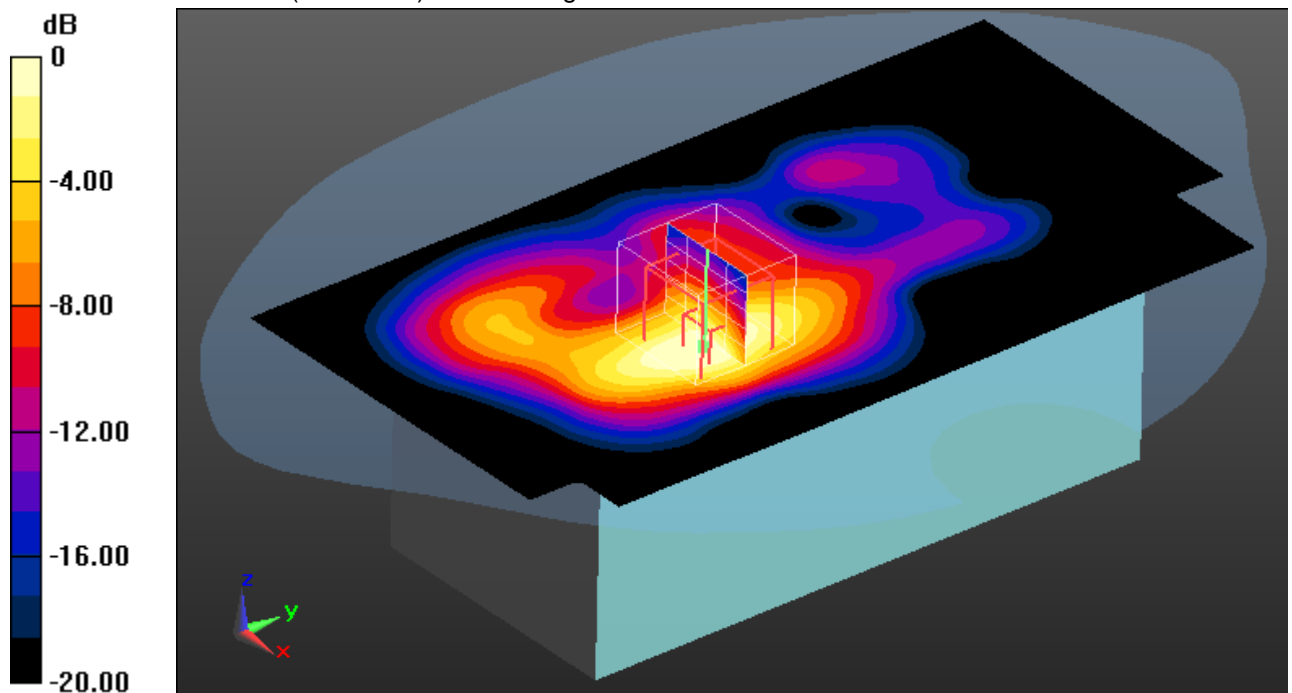

0 dB = 2.45 W/kg = 3.89 dBW/kg

Additional information:

position or distance of DUT to the phantom: 0 mm

ambient temperature: 23.8°C; liquid temperature: 21.9°C

Annex B.1: Liquid depth

Photo 1: Liquid depth 750 MHz body simulating liquid



Photo 2: Liquid depth 850 MHz body simulating liquid



Photo 3: Liquid depth 1750 MHz body simulating liquid

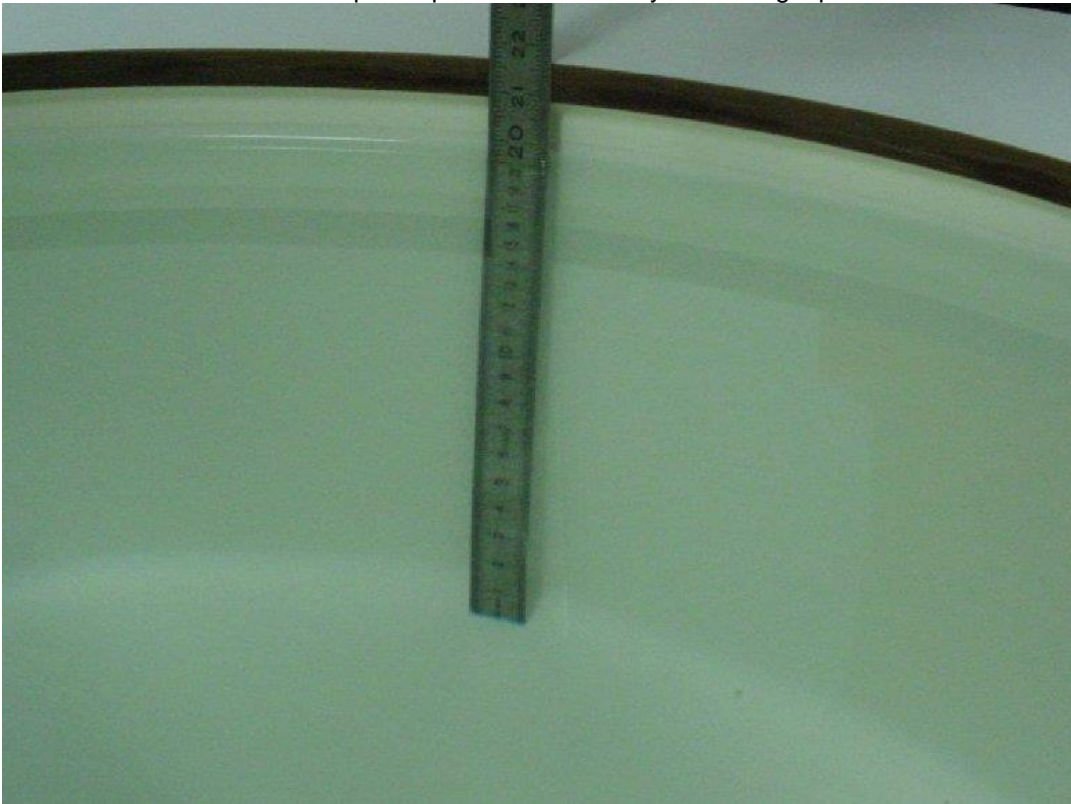

Photo 4: Liquid depth 1900 MHz body simulating liquid

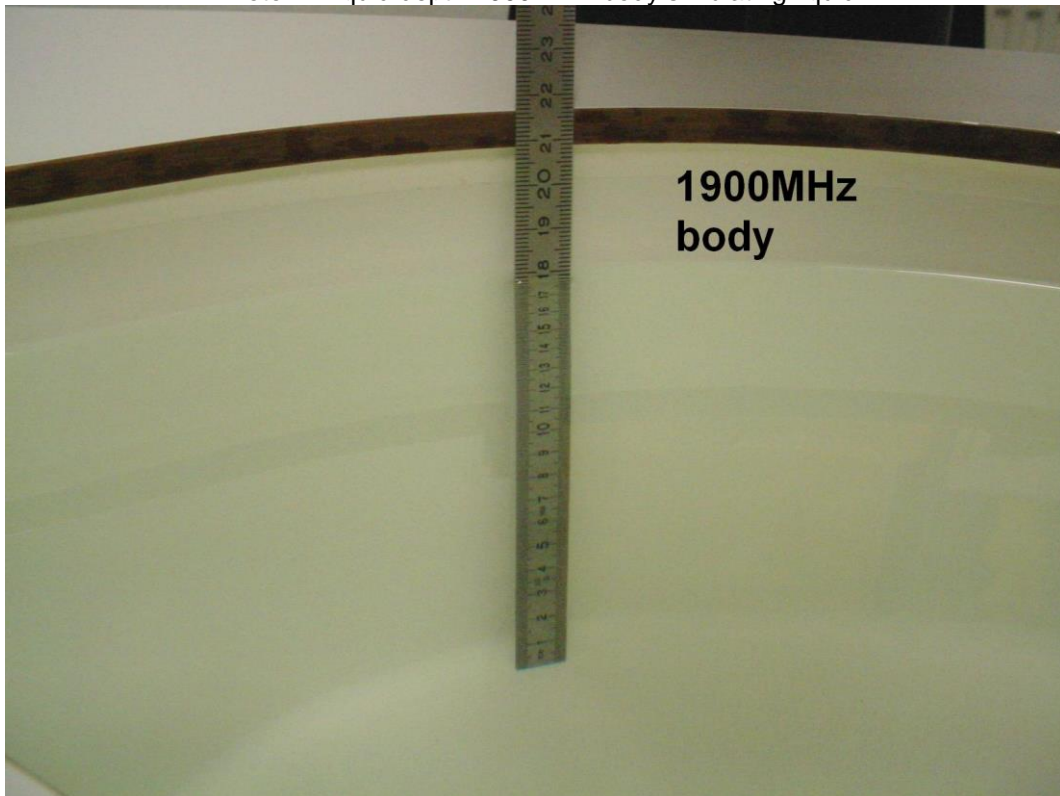
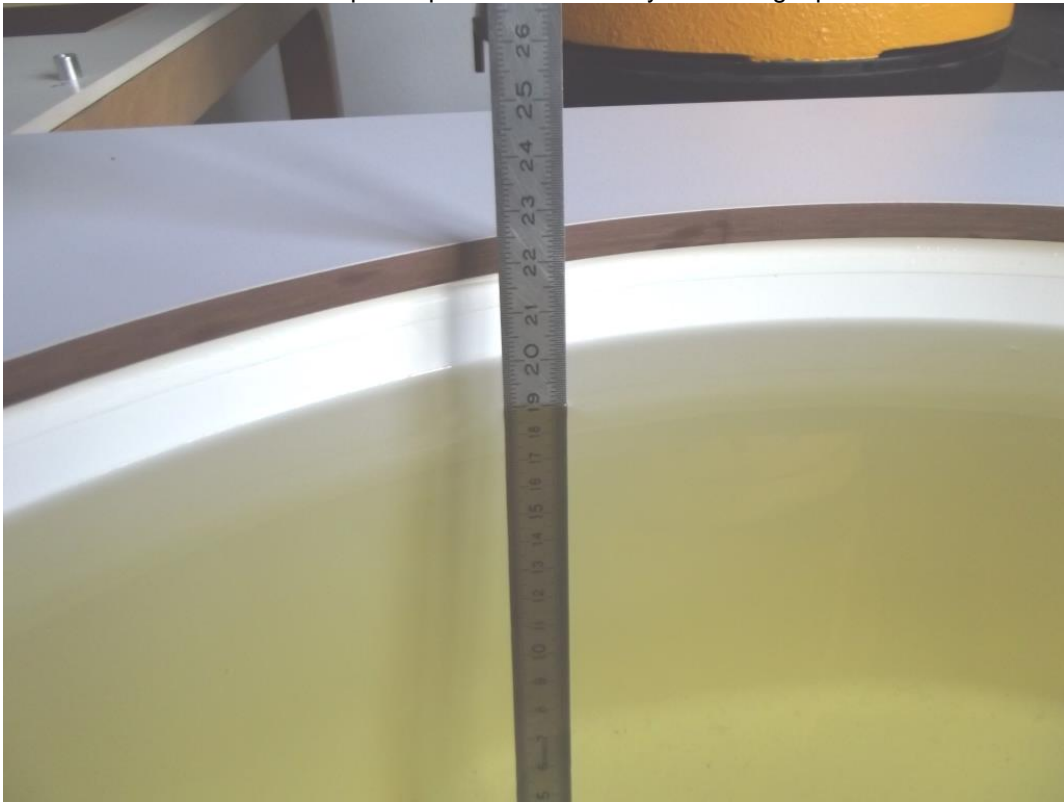

Photo 5: Liquid depth 2450 MHz body simulating liquid



Annex C: Photo documentation

Photo documentation is described in the additional document:

Appendix to test report no. 1-5566/17-01-02-A Photo documentation

Annex D: Calibration parameters

Calibration parameters are described in the additional document:

Appendix to test report no. 1-5566/17-01-02-A Calibration data, Phantom certificate and detail information of the DASY5 System

Annex E: RSS-102 Annex A and B

ICRF documents are described in the additional document:

Appendix to test report no. 1-5566/17-01-02-A_ICRF RF Technical Brief Cover Sheet acc. To RSS-102 Annex A and Declaration of RX Exposure Compliance Annex B

Annex F: Document History

Version	Applied Changes	Date of Release
	Initial Release	2018-03-16
-A	Test Item was completed	2018-04-03

Annex G: Further Information

Glossary

BW	-	Bandwidth
DTS	-	Distributed Transmission System
DUT	-	Device under Test
EUT	-	Equipment under Test
FCC	-	Federal Communication Commission
FCC ID	-	Company Identifier at FCC
HW	-	Hardware
IC	-	Industry Canada
Inv. No.	-	Inventory number
LTE	-	Long Term Evolution
N/A	-	not applicable
OET	-	Office of Engineering and Technology
RB	-	resource block(s)
SAR	-	Specific Absorption Rate
S/N	-	Serial Number
SW	-	Software
UNII	-	Unlicensed National Information Infrastructure