



TEST REPORT

Test report no.: 1-9148/19-01-04

BNetzA-CAB-02/21-102

Testing laboratory

CTC advanced GmbH

Untertuerkheimer Strasse 6 – 10

66117 Saarbruecken / Germany

Phone: + 49 681 5 98 - 0

Fax: + 49 681 5 98 - 9075

Internet: <http://www.ctcadvanced.com>

e-mail: mail@ctcadvanced.com

Accredited Testing Laboratory:

The testing laboratory (area of testing) is accredited according to DIN EN ISO/IEC 17025 (2005) by the Deutsche Akkreditierungsstelle GmbH (DAkkS)

The accreditation is valid for the scope of testing procedures as stated in the accreditation certificate starting with the registration number: D-PL-12076-01.

Applicant

Ingenico Group

9 Avenue de la Gare Rovaltain

26958 Valence Cedex 9 / FRANCE

Phone: -/-

Contact: Georges Allemand

e-mail: georges.allemand@ingenico.com

Phone: +33 4 75 84 20 14

Manufacturer

Ingenico Group

9 Avenue de la Gare Rovaltain

26958 Valence Cedex 9 / FRANCE

Test standard/s

FCC - Title 47 CFR Part 15 FCC - Title 47 of the Code of Federal Regulations; Chapter I; Part 15 - Radio frequency devices

RSS - 247 Issue 2 Digital Transmission Systems (DTSS), Frequency Hopping Systems (FHSs) and Licence - Exempt Local Area Network (LE-LAN) Devices

For further applied test standards please refer to section 3 of this test report.

Test Item

Kind of test item: **Payment Terminal**
Model name: **Lane/3000 CL/Eth/WiFi/BT**
FCC ID: **XKB-L3000CLWIBT**
IC: **2586D-L3000CLWIBT**
Frequency: UNII bands 5150 MHz to 5850 MHz
Technology tested: WLAN
Antenna: Integrated antenna
Power supply: 8 V DC / 115 V AC by mains adapter PSC16A-080L6
Temperature range: 0°C to +40°C

This test report is electronically signed and valid without handwritten signature. For verification of the electronic signatures, the public keys can be requested at the testing laboratory.

Test report authorized:



Marco Bertolino
Lab Manager
Radio Communications & EMC

Test performed:



Mihail Dorongovskij
Lab Manager
Radio Communications & EMC

1 Table of contents

1	Table of contents	2
2	General information	4
2.1	Notes and disclaimer	4
2.2	Application details	4
2.3	Test laboratories sub-contracted	4
3	Test standard/s, references and accreditations	5
4	Test environment	6
5	Test item	6
5.1	General description	6
5.2	Additional information	6
6	Description of the test setup.....	7
6.1	Shielded semi anechoic chamber	8
6.2	Shielded fully anechoic chamber.....	9
6.3	Radiated measurements > 18 GHz.....	10
6.4	Conducted measurements with peak power meter & spectrum analyzer	11
6.5	AC conducted	12
6.6	Shielded fully anechoic chamber.....	13
7	Sequence of testing	14
7.1	Sequence of testing radiated spurious 9 kHz to 30 MHz	14
7.2	Sequence of testing radiated spurious 30 MHz to 1 GHz	15
7.3	Sequence of testing radiated spurious 1 GHz to 18 GHz	16
7.4	Sequence of testing radiated spurious above 18 GHz	17
8	Measurement uncertainty	18
9	Summary of measurement results	19
10	Additional comments	20
11	Measurement results.....	23
11.1	Identify worst case data rate	23
11.2	Antenna gain.....	24
11.3	Duty cycle	25
11.4	Maximum output power.....	26
11.4.1	Maximum output power according to FCC requirements.....	26
11.4.2	Maximum output power according to IC requirements	29
11.5	Power spectral density	33
11.5.1	Power spectral density according to FCC requirements.....	33
11.5.2	Power spectral density according to IC requirements	36
11.6	Minimum emission bandwidth for the band 5.725-5.85 GHz.....	39
11.7	Spectrum bandwidth / 26 dB bandwidth.....	41
11.8	Occupied bandwidth / 99% emission bandwidth	44
11.9	Band edge compliance radiated.....	47
11.10	Spurious emissions radiated below 30 MHz.....	51
11.11	Spurious emissions radiated 30 MHz to 1 GHz	62

11.12	Spurious emissions radiated 1 GHz to 40 GHz	85
11.13	Spurious emissions conducted below 30 MHz (AC conducted).....	119
12	Observations	121
Annex A	Glossary.....	122
Annex B	Document history	123
Annex C	Accreditation Certificate – D-PL-12076-01-04.....	123
Annex D	Accreditation Certificate – D-PL-12076-01-05.....	124

2 General information

2.1 Notes and disclaimer

The test results of this test report relate exclusively to the test item specified in this test report. CTC advanced GmbH does not assume responsibility for any conclusions and generalizations drawn from the test results with regard to other specimens or samples of the type of the equipment represented by the test item.

The test report may only be reproduced or published in full. Reproduction or publication of extracts from the report requires the prior written approval of CTC advanced GmbH.

The testing service provided by CTC advanced GmbH has been rendered under the current "General Terms and Conditions for CTC advanced GmbH".

CTC advanced GmbH will not be liable for any loss or damage resulting from false, inaccurate, inappropriate or incomplete product information provided by the customer.

Under no circumstances does the CTC advanced GmbH test report include any endorsement or warranty regarding the functionality, quality or performance of any other product or service provided.

Under no circumstances does the CTC advanced GmbH test report include or imply any product or service warranties from CTC advanced GmbH, including, without limitation, any implied warranties of merchantability, fitness for purpose, or non-infringement, all of which are expressly disclaimed by CTC advanced GmbH.

All rights and remedies regarding vendor's products and services for which CTC advanced GmbH has prepared this test report shall be provided by the party offering such products or services and not by CTC advanced GmbH. In no case this test report can be considered as a Letter of Approval.

This test report is electronically signed and valid without handwritten signature. For verification of the electronic signatures, the public keys can be requested at the testing laboratory.

2.2 Application details

Date of receipt of order:	2019-12-09
Date of receipt of test item:	2020-01-14
Start of test:	2020-01-14
End of test:	2020-02-05
Person(s) present during the test:	-/-

2.3 Test laboratories sub-contracted

None

3 Test standard/s, references and accreditations

Test standard	Date	Description
FCC - Title 47 CFR Part 15	-/-	FCC - Title 47 of the Code of Federal Regulations; Chapter I; Part 15 - Radio frequency devices
RSS - 247 Issue 2	February 2017	Digital Transmission Systems (DTSs), Frequency Hopping Systems (FHSs) and Licence - Exempt Local Area Network (LE-LAN) Devices
RSS - Gen Issue 5 incl. Amendment 1	March 2019	Spectrum Management and Telecommunications Radio Standards Specification - General Requirements for Compliance of Radio Apparatus

Guidance	Version	Description
KDB 789033 D02	v02r01	Guidelines for Compliance Testing of Unlicensed National Information Infrastructure (U-NII) Devices - Part 15, Subpart E
ANSI C63.4-2014	-/-	American National Standard for Methods of Measurement of Radio-Noise Emissions from Low-Voltage Electrical and Electronic Equipment in the Range of 9 kHz to 40 GHz
ANSI C63.10-2013	-/-	American National Standard of Procedures for Compliance Testing of Unlicensed Wireless Devices

Accreditation	Description	
D-PL-12076-01-04	Telecommunication and EMC Canada https://www.dakks.de/as/ast/d/D-PL-12076-01-04.pdf	  Deutsche Akkreditierungsstelle D-PL-12076-01-04
D-PL-12076-01-05	Telecommunication FCC requirements https://www.dakks.de/as/ast/d/D-PL-12076-01-05.pdf	  Deutsche Akkreditierungsstelle D-PL-12076-01-05

4 Test environment

Temperature	:	T_{nom} +24 °C during room temperature tests T_{max} No tests under extreme temperature conditions required. T_{min} No tests under extreme temperature conditions required.
Relative humidity content	:	46 %
Barometric pressure	:	1014 hpa
Power supply	:	V_{nom} 8 V DC / 115 V AC by mains adapter PSC16A-080L6 V_{max} No tests under extreme voltage conditions required. V_{min} No tests under extreme voltage conditions required.

5 Test item

5.1 General description

Kind of test item	:	Payment Terminal
Model name	:	Lane/3000 CL/Eth/WiFi/BT
HMN	:	n/a
PMN	:	Lane/3000
HVIN	:	Lane/3000 CL/Eth/WiFi/BT
FVIN	:	n/a
S/N serial number	:	Radiated unit: 181397313011070602695494 Conducted unit: 181397313011070602695500
Hardware status	:	01
Software status	:	OS Version 038605/ Appli Version 010299
Firmware status	:	-/-
Frequency band	:	UNII bands 5150 MHz to 5850 MHz
Type of radio transmission	:	OFDM
Use of frequency spectrum	:	
Type of modulation	:	(D)BPSK, (D)QPSK, 16 – QAM, 64 – QAM
Number of channels	:	20 MHz: 21 40 MHz: 11
Antenna	:	Integrated antenna
Power supply	:	8 V DC / 115 V AC by mains adapter PSC16A-080L6
Temperature range	:	0°C to +40°C

5.2 Additional information

The content of the following annexes is defined in the QA. It may be that not all of the listed annexes are necessary for this report, thus some values in between may be missing.

Test setup and EUT photos are included in test report:

- 1-9148/19-01-01_AnnexA
- 1-9148/19-01-01_AnnexB
- 1-9148/19-01-01_AnnexD

6 Description of the test setup

Typically, the calibrations of the test apparatus are commissioned to and performed by an accredited calibration laboratory. The calibration intervals are determined in accordance with the DIN EN ISO/IEC 17025. In addition to the external calibrations, the laboratory executes comparison measurements with other calibrated test systems or effective verifications. Weekly chamber inspections and range calibrations are performed. Where possible, RF generating and signaling equipment as well as measuring receivers and analyzers are connected to an external high-precision 10 MHz reference (GPS-based or rubidium frequency standard).

In order to simplify the identification of the equipment used at some special tests, some items of test equipment and ancillaries can be provided with an identifier or number in the equipment list below (Lab/Item).

Agenda: Kind of Calibration

k	calibration / calibrated	EK	limited calibration
ne	not required (k, ev, izw, zw not required)	zw	cyclical maintenance (external cyclical maintenance)
ev	periodic self verification	izw	internal cyclical maintenance
Ve	long-term stability recognized	g	blocked for accredited testing
vlk!	Attention: extended calibration interval		
NK!	Attention: not calibrated	*)	next calibration ordered / currently in progress

6.1 Shielded semi anechoic chamber

The radiated measurements are performed in vertical and horizontal plane in the frequency range from 30 MHz to 1 GHz in semi-anechoic chambers. The EUT is positioned on a non-conductive support with a height of 0.80 m above a conductive ground plane that covers the whole chamber. The receiving antennas are conform to specifications ANSI C63. These antennas can be moved over the height range between 1.0 m and 4.0 m in order to search for maximum field strength emitted from EUT. The measurement distances between EUT and receiving antennas are indicated in the test setups for the various frequency ranges. For each measurement, the EUT is rotated in all three axes until the maximum field strength is received. The wanted and unwanted emissions are received by spectrum analyzers where the detector modes and resolution bandwidths over various frequency ranges are set according to requirement ANSI C63.

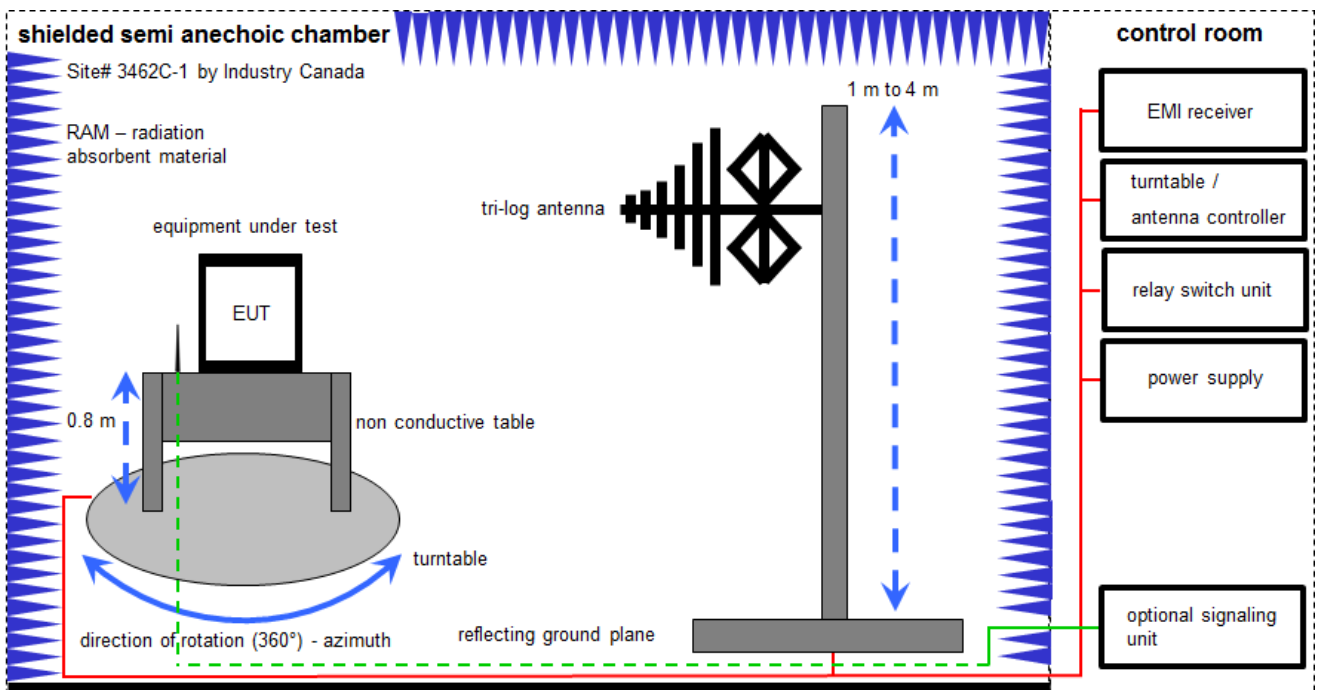

Measurement distance: tri-log antenna 10 meter; EMC32 software version: 10.30.0

FS = UR + CL + AF (FS-field strength; UR-voltage at the receiver; CL-loss of the cable; AF-antenna factor)

Example calculation:

$$FS \text{ [dB}\mu\text{V/m]} = 12.35 \text{ [dB}\mu\text{V/m]} + 1.90 \text{ [dB]} + 16.80 \text{ [dB/m]} = 31.05 \text{ [dB}\mu\text{V/m]} \text{ (35.69 } \mu\text{V/m)}$$

Equipment table:

No.	Lab / Item	Equipment	Type	Manufacturer	Serial No.	INV. No.	Kind of Calibration	Last Calibration	Next Calibration
1	A	Switch-Unit	3488A	HP	2719A14505	300000368	ev	-/-	-/-
2	A	Meßkabine 1	HF-Absorberhalle	MWB AG 300023	-/-	300000551	ne	-/-	-/-
3	A	Analyzer-Reference-System (Harmonics and Flicker)	ARS 16/1	SPS	A3509 07/0 0205	300003314	vIKI!	15.01.2018	14.01.2020
4	A	Analyzer-Reference-System (Harmonics and Flicker)	ARS 16/1	SPS	A3509 07/0 0205	300003314	vIKI!	17.01.2020	16.01.2022
5	A	Antenna Tower	Model 2175	ETS-Lindgren	64762	300003745	izw	-/-	-/-
6	A	Positioning Controller	Model 2090	ETS-Lindgren	64672	300003746	izw	-/-	-/-
7	A	Turntable Interface-Box	Model 105637	ETS-Lindgren	44583	300003747	izw	-/-	-/-
8	A	TRILOG Broadband Test-Antenna 30 MHz - 3 GHz	VULB9163	Schwarzbeck Mess-Elektronik	295	300003787	vIKI!	19.02.2019	18.02.2021
9	A	EMI Test Receiver	ESR3	Rohde & Schwarz	102587	300005771	k	21.05.2019	20.05.2020

6.2 Shielded fully anechoic chamber

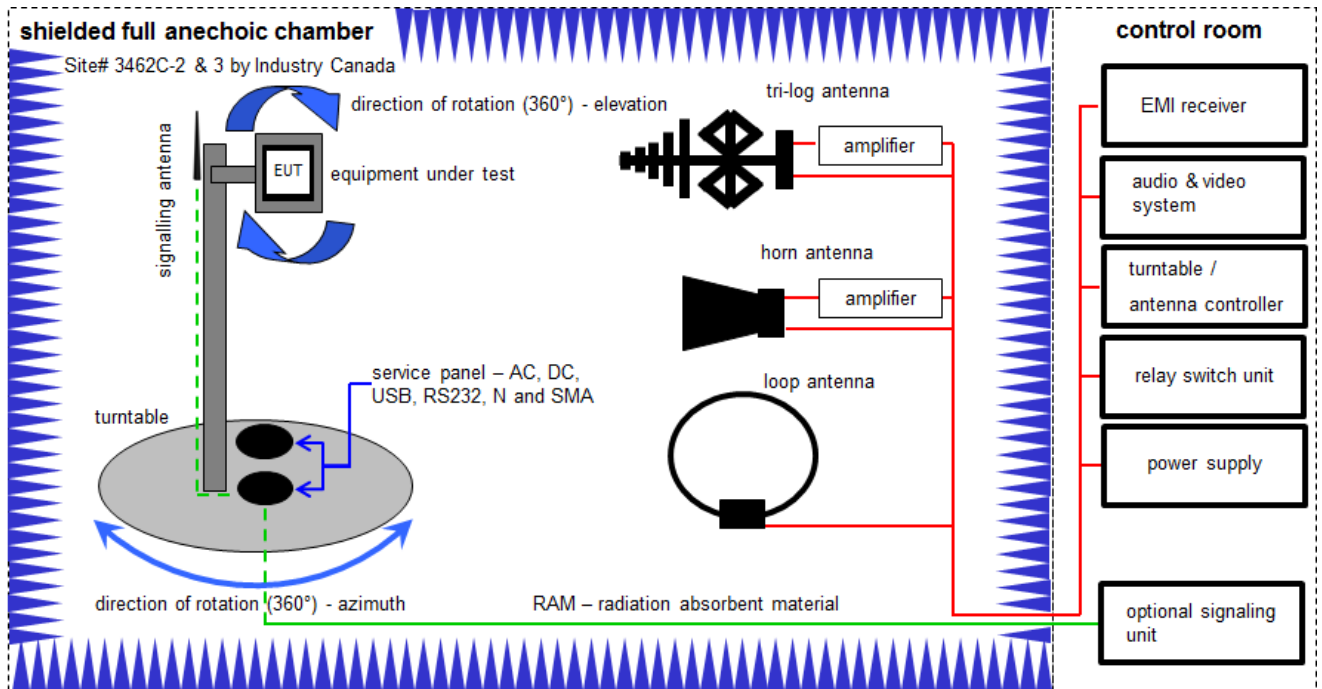

Measurement distance: tri-log antenna and horn antenna 3 meter; loop antenna 3 meter

FS = UR + CA + AF

(FS-field strength; UR-voltage at the receiver; CA-loss of the signal path; AF-antenna factor)

Example calculation:

FS [dB μ V/m] = 40.0 [dB μ V/m] + (-35.8) [dB] + 32.9 [dB/m] = 37.1 [dB μ V/m] (71.61 μ V/m)

Equipment table:

No.	Lab / Item	Equipment	Type	Manufacturer	Serial No.	INV. No.	Kind of Calibration	Last Calibration	Next Calibration
1	C	Active Loop Antenna 9 kHz to 30 MHz	6502	EMCO	2210	300001015	vKI!	13.06.2019	12.06.2021
2	A, B, C	Anechoic chamber	FAC 3/5m	MWB / TDK	87400/02	300000996	ev	-/-	-/-
3	A, B	Double-Ridged Waveguide Horn Antenna 1-18.0GHz	3115	EMCO	9107-3697	300001605	vKI!	27.02.2019	26.02.2021
4	A, B, C	Switch / Control Unit	3488A	HP	*	300000199	ne	-/-	-/-
5	A, B, C	Variable isolating transformer	MPL IEC625 Bus Variable isolating transformer	Erfi	91350	300001155	ne	-/-	-/-
6	A, B, C	EMI Test Receiver 20Hz- 26,5GHz	ESU26	R&S	100037	300003555	k	11.12.2019	10.12.2020
7	A	Highpass Filter	WHK1.1/15G-10SS	Wainwright	3	300003255	ev	-/-	-/-
8	A	Highpass Filter	WHKX7.0/18G-8SS	Wainwright	19	300003790	ne	-/-	-/-
9	A	Broadband Amplifier 0.5-18 GHz	CBLU5184540	CERNEX	22049	300004481	ev	-/-	-/-
10	A, B, C	4U RF Switch Platform	L4491A	Agilent Technologies	MY50000037	300004509	ne	-/-	-/-
11	A, B, C	NEXIO EMV-Software	BAT EMC V3.19.1.9	EMCO	-/-	300004682	ne	-/-	-/-
12	A, B, C	PC	ExOne	F+W	-/-	300004703	ne	-/-	-/-
13	A	RF-Amplifier	AMF-6F06001800-30-10P-R	NARDA-MITEQ Inc	2011572	300005241	ev	-/-	-/-
14	A	High Pass Filter	VHF-3500+	Mini Circuits	-/-	400000193	ne	-/-	-/-

6.3 Radiated measurements > 18 GHz

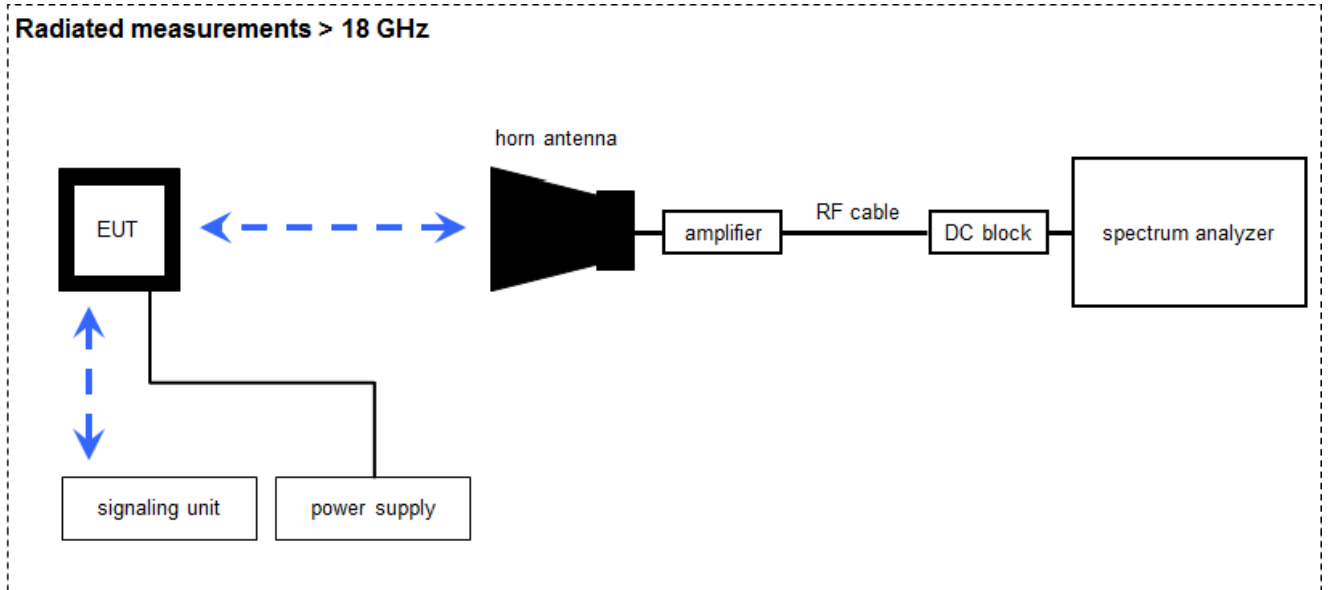

Measurement distance: horn antenna 50 cm

$$FS = UR + CA + AF$$

(FS-field strength; UR-voltage at the receiver; CA-loss signal path & distance correction; AF-antenna factor)

Example calculation:

$$FS [dB\mu V/m] = 40.0 [dB\mu V/m] + (-60.1) [dB] + 36.74 [dB/m] = 16.64 [dB\mu V/m] (6.79 \mu V/m)$$

Equipment table:

No.	Lab / Item	Equipment	Type	Manufacturer	Serial No.	INV. No.	Kind of Calibration	Last Calibration	Next Calibration
1	A	Broadband Low Noise Amplifier 18-50 GHz	CBL18503070-XX	CERNEX	19338	300004273	ev	-/-	-/-
2	A	Horn Antenna 18.0-40.0 GHz	LHAF180	Microw.Devel	39180-103-021	300001747	vIKI!	18.02.2019	17.02.2022
3	A	DC-Blocker	WA7046	Weinschel Associates	-/-	400001310	ev	-/-	-/-
4	A	RF-Cable	ST18/SMAm/SMAm /48	Huber & Suhner	Batch no. 600918	400001182	ev	-/-	-/-
5	A	RF-Cable	ST18/SMAm/SMAm /48	Huber & Suhner	Batch no. 127377	400001183	ev	-/-	-/-
6	A	Signal Analyzer 40 GHz	FSV40	R&S	101042	300004517	k	17.12.2019	16.12.2020

6.4 Conducted measurements with peak power meter & spectrum analyzer

Conducted measurements normal conditions

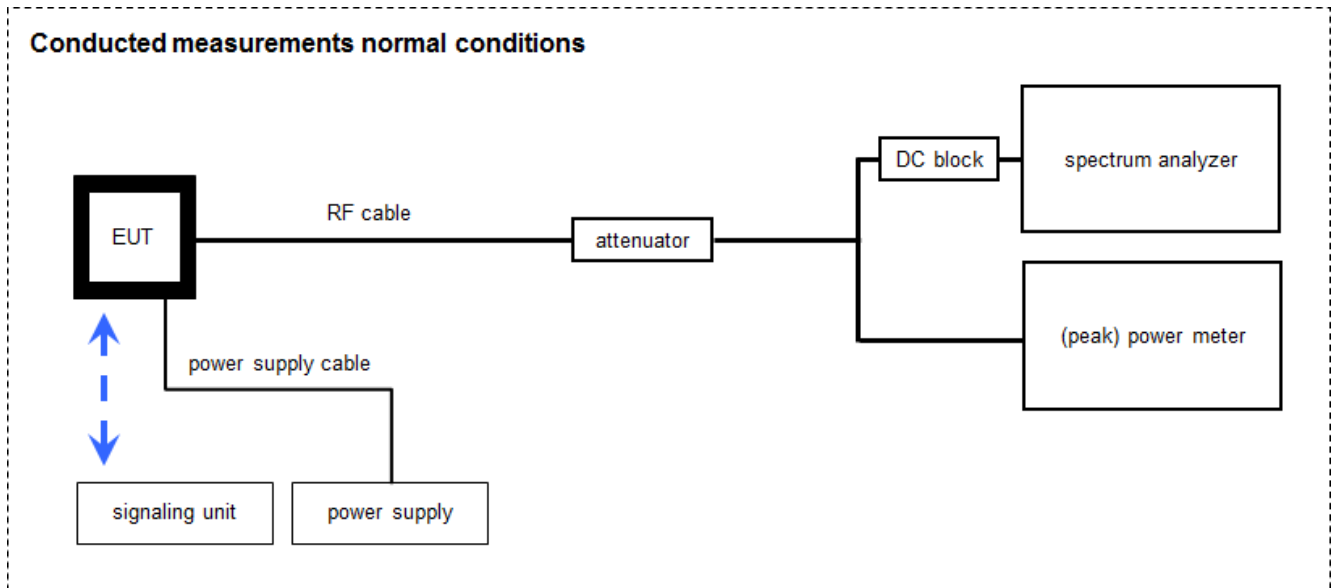

OP = AV + CA
(OP-output power; AV-analyzer value; CA-loss signal path)

Example calculation:

OP [dBm] = 6.0 [dBm] + 11.7 [dB] = 17.7 [dBm] (58.88 mW)

Equipment table:

No.	Lab / Item	Equipment	Type	Manufacturer	Serial No.	INV. No.	Kind of Calibration	Last Calibration	Next Calibration
1	A	Signal Analyzer 40 GHz	FSV40	R&S	101042	300004517	k	17.12.2019	16.12.2020
2	A	DC-Blocker 0.1-40 GHz	8141A	Inmet	-/-	400001185	ev	-/-	-/-
3	A	Isolating Transformer	RT5A	Grundig	12780	300001166	ev	-/-	-/-
4	A	Hygro-Thermometer	-/-, 5-45°C, 20-100%rF	Thies Clima	-/-	400000108	ev	11.05.2018	10.05.2020
5	A	PC Tester R005	Intel Core i3 3220/3,3 GHz, Prozessor	-/-	2V2403033A45 23	300004589	ne	-/-	-/-
6	A	RF-Cable	ST18/SMAm/SMAm /60	Huber & Suhner	Batch no. 606844	400001181	ev	-/-	-/-
7	A	Coax Attenuator 10 dB 2W 0-40 GHz	MCL BW-K10-2W44+	Mini Circuits	-/-	400001186	ev	-/-	-/-
8	A	DC-Blocker	WA7046	Weinschel Associates	-/-	400001310	ev	-/-	-/-
9	A	Tester Software RadioStar	Version 1.0.0.X	CTC advanced GmbH	0001	400001380	ne	-/-	-/-

6.5 AC conducted

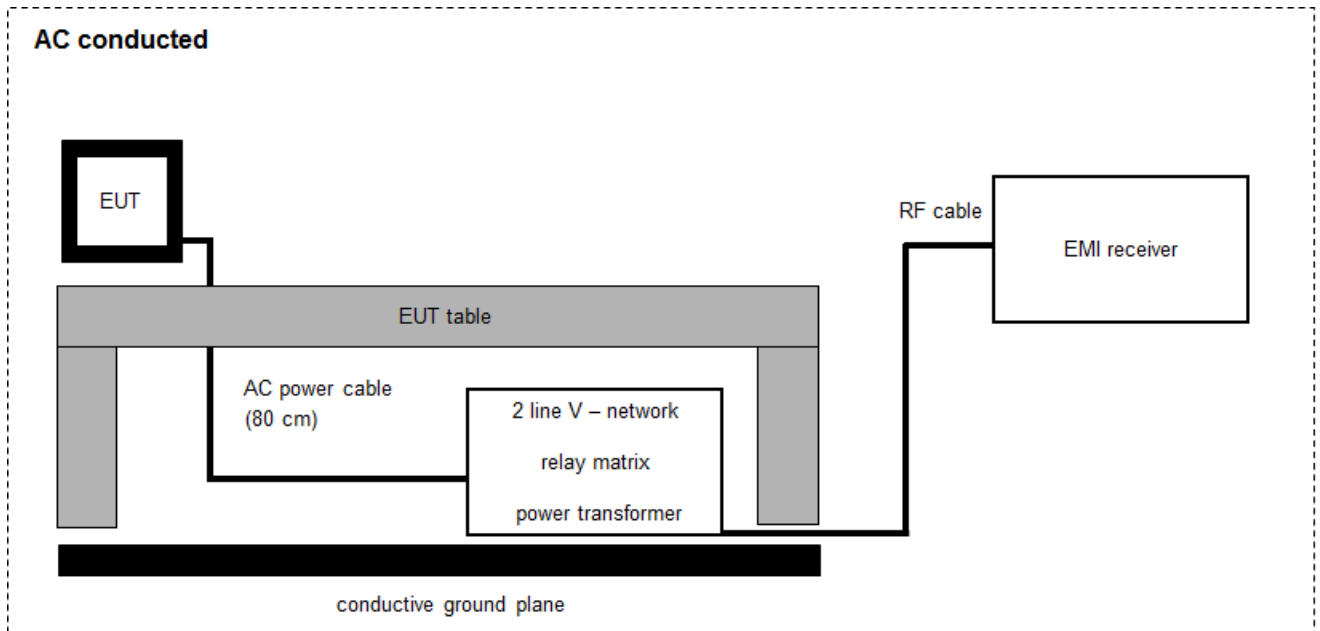

$$FS = UR + CF + VC$$

(FS-field strength; UR-voltage at the receiver; CR-loss of the cable and filter; VC-correction factor of the ISN)

Example calculation:

$$FS [dB\mu V/m] = 37.62 [dB\mu V/m] + 9.90 [dB] + 0.23 [dB] = 47.75 [dB\mu V/m] \quad (244.06 \mu V/m)$$

Equipment table:

No.	Lab / Item	Equipment	Type	Manufacturer	Serial No.	INV. No.	Kind of Calibration	Last Calibration	Next Calibration
1	A	Two-line V-Network (LISN) 9 kHz to 30 MHz	ESH3-Z5	R&S	892475/017	300002209	vIKI!	11.12.2019	10.12.2021
2	A	RF-Filter-section	85420E	HP	3427A00162	300002214	NK!	-/-	-/-
3	A	EMI Test Receiver	ESCI 3	R&S	100083	300003312	k	10.12.2019	09.12.2020
4	A	Hochpass 150 kHz	EZ-25	R&S	100010	300003798	ev	-/-	-/-

6.6 Shielded fully anechoic chamber

OTA – over the air performance

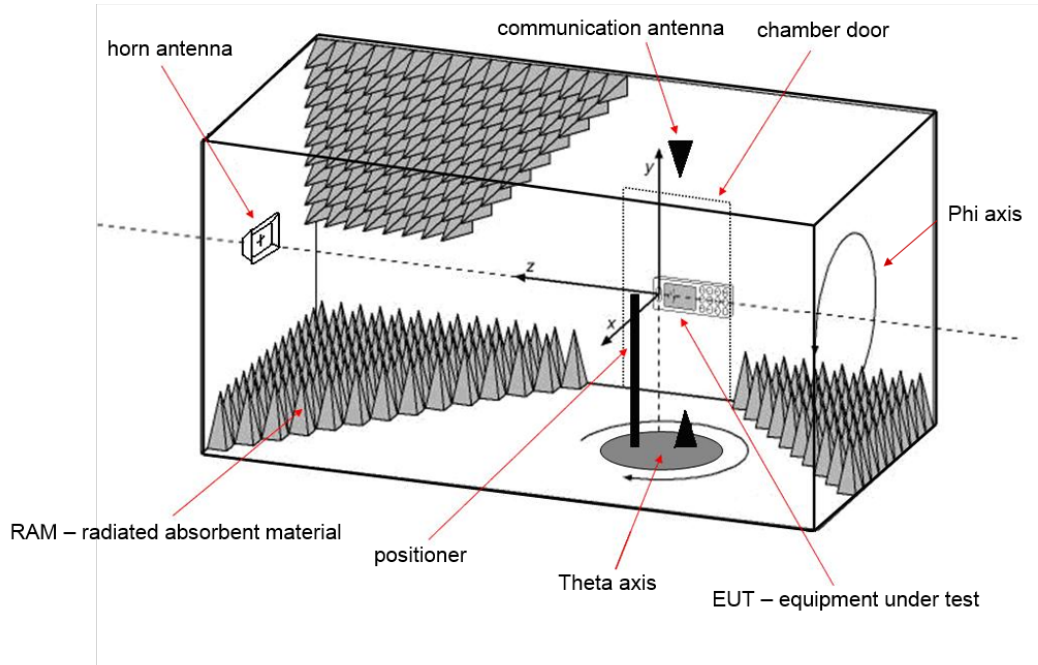

EM Quest software version: 1.0.7.0

$$OP = AV + D - G + CA$$

(OP-radiated output power; AV-analyzer value; D-free field attenuation of measurement distance; G-antenna gain+amplifier gain; CA-loss signal path)

Example calculation:

$$OP \text{ [dBm]} = -40.0 \text{ [dBm]} + 49.9 \text{ [dB]} - 12.4 \text{ [dBi]} + 9 \text{ [dB]} = 6.5 \text{ [dBm]} \text{ (4.47 mW)}$$

Equipment table:

No.	Lab / Item	Equipment	Type	Manufacturer	Serial No.	INV. No.	Kind of Calibration	Last Calibration	Next Calibration
1	A	Splitter	42000	Anaren	4730	400000085	ev	-/-	-/-
2	A	Switch Unit	TS-RSP	R&S	100155	300003281	ev	-/-	-/-
3	A	CTIA-Chamber	CTIA-Chamber AMS 8500	ETS-Lindgren Finland	100083	300003327	ne	-/-	-/-
4	A	CTIA-Chamber - Positioning Equipment	CTIA-Chamber - Positioning Equipment	EMCO/2		300003328	ne	-/-	-/-
5	A	CTIA-Chamber - Software	CTIA-Chamber - Software	EMCO/2	A3509 07/0 0205	300003328	ne	-/-	-/-
6	A	CTIA-Chamber - Antenna	3164-04	EMCO/2	00041915	300003328	ne	-/-	-/-
7	A	Spectrum Analyzer 9kHz - 30 GHz	FSP30	R&S	100623	300003464	vKI!	13.12.2018	12.12.2020

7 Sequence of testing

7.1 Sequence of testing radiated spurious 9 kHz to 30 MHz

Setup

- The equipment is set up to simulate normal operation mode as described in the user manual or defined by the manufacturer.
- If the EUT is a tabletop system, it is placed on a table with 0.8 m height.
- If the EUT is a floor standing device, it is placed directly on the turn table.
- Auxiliary equipment and cables are positioned to simulate normal operation conditions as described in ANSI C 63.4.
- The AC power port of the EUT (if available) is connected to a power outlet below the turntable.
- Measurement distance is 3 m (see ANSI C 63.4) – see test details.
- EUT is set into operation.

Premeasurement*

- The turntable rotates from 0° to 315° using 45° steps.
- The antenna height is 1 m.
- At each turntable position the analyzer sweeps with positive-peak detector to find the maximum of all emissions.

Final measurement

- Identified emissions during the pre-measurement are maximized by the software by rotating the turntable from 0° to 360°.
- Loop antenna is rotated about its vertical axis for maximum response at each azimuth about the EUT. (For certain applications, the loop antenna plane may also need to be positioned horizontally at the specified distance from the EUT)
- The final measurement is done in the position (turntable and elevation) causing the highest emissions with quasi-peak (as described in ANSI C 63.4).
- Final levels, frequency, measuring time, bandwidth, turntable position, correction factor, margin to the limit and limit will be recorded. A plot with the graph of the premeasurement and the limit is stored.

*Note: The sequence will be repeated three times with different EUT orientations.

7.2 Sequence of testing radiated spurious 30 MHz to 1 GHz

Setup

- The equipment is set up to simulate normal operation mode as described in the user manual or defined by the manufacturer.
- If the EUT is a tabletop system, a table with 0.8 m height is used, which is placed on the ground plane.
- If the EUT is a floor standing device, it is placed on the ground plane with insulation between both.
- Auxiliary equipment and cables are positioned to simulate normal operation conditions as described in ANSI C 63.4.
- The AC power port of the EUT (if available) is connected to a power outlet below the turntable.
- Measurement distance is 10 m or 3 m (see ANSI C 63.4) – see test details.
- EUT is set into operation.

Premeasurement

- The turntable rotates from 0° to 315° using 45° steps.
- The antenna is polarized vertical and horizontal.
- The antenna height changes from 1 m to 3 m.
- At each turntable position, antenna polarization and height the analyzer sweeps three times in peak to find the maximum of all emissions.

Final measurement

- The final measurement is performed for at least six highest peaks according to the requirements of the ANSI C63.4.
- Based on antenna and turntable positions at which the peak values are measured the software maximize the peaks by changing turntable position $\pm 45^\circ$ and antenna height between 1 and 4 m.
- The final measurement is done with quasi-peak detector (as described in ANSI C 63.4).
- Final levels, frequency, measuring time, bandwidth, antenna height, antenna polarization, turntable angle, correction factor, margin to the limit and limit are recorded. A plot with the graph of the premeasurement with marked maximum final results and the limit is stored.

7.3 Sequence of testing radiated spurious 1 GHz to 18 GHz

Setup

- The equipment is set up to simulate normal operation mode as described in the user manual or defined by the manufacturer.
- If the EUT is a tabletop system, a 2-axis positioner with 1.5 m height is used.
- If the EUT is a floor standing device, it is placed directly on the turn table.
- Auxiliary equipment and cables are positioned to simulate normal operation conditions as described in ANSI C 63.4.
- The AC power port of the EUT (if available) is connected to a power outlet below the turntable.
- Measurement distance is 3 m (see ANSI C 63.4) – see test details.
- EUT is set into operation.

Premeasurement

- The turntable rotates from 0° to 315° using 45° steps.
- The antenna is polarized vertical and horizontal.
- The antenna height is 1.5 m.
- At each turntable position and antenna polarization the analyzer sweeps with positive peak detector to find the maximum of all emissions.

Final measurement

- The final measurement is performed for at least six highest peaks according to the requirements of the ANSI C63.4.
- Based on antenna and turntable positions at which the peak values are measured the software maximizes the peaks by rotating the turntable from 0° to 360°. This measurement is repeated for different EUT-table positions (0° to 150° in 30°-steps) and for both antenna polarizations.
- The final measurement is done in the position (turntable, EUT-table and antenna polarization) causing the highest emissions with Peak and RMS detector (as described in ANSI C 63.4).
- Final levels, frequency, measuring time, bandwidth, turntable position, EUT-table position, antenna polarization, correction factor, margin to the limit and limit are recorded. A plot with the graph of the premeasurement with marked maximum final results and the limit is stored.

7.4 Sequence of testing radiated spurious above 18 GHz

Setup

- The equipment is set up to simulate normal operation mode as described in the user manual or defined by the manufacturer.
- Auxiliary equipment and cables are positioned to simulate normal operation conditions as described in ANSI C 63.4.
- The AC power port of the EUT (if available) is connected to a power outlet.
- The measurement distance is as appropriate (e.g. 0.5 m).
- The EUT is set into operation.

Premeasurement

- The test antenna is handheld and moved carefully over the EUT to cover the EUT's whole sphere and different polarizations of the antenna.

Final measurement

- The final measurement is performed at the position and antenna orientation causing the highest emissions with Peak and RMS detector (as described in ANSI C 63.4).
- Final levels, frequency, measuring time, bandwidth, correction factor, margin to the limit and limit are recorded. A plot with the graph of the premeasurement and the limit is stored.

8 Measurement uncertainty

Measurement uncertainty		
Test case	Uncertainty	
Antenna gain	± 3 dB	
Power spectral density	± 1.15 dB	
Spectrum bandwidth	± 100 kHz (depends on the used RBW)	
Occupied bandwidth	± 100 kHz (depends on the used RBW)	
Maximum output power	± 1.15 dB conducted ± 3 dB radiated	
Minimum emissions bandwidth	± 100 kHz (depends on the used RBW)	
Band edge compliance radiated	± 3 dB	
Spurious emissions conducted	> 3.6 GHz	± 1.15 dB
	> 7 GHz	± 1.15 dB
	> 18 GHz	± 1.89 dB
	≥ 40 GHz	± 3.12 dB
Spurious emissions radiated below 30 MHz	± 3 dB	
Spurious emissions radiated 30 MHz to 1 GHz	± 3 dB	
Spurious emissions radiated 1 GHz to 12.75 GHz	± 3.7 dB	
Spurious emissions radiated above 12.75 GHz	± 4.5 dB	
Spurious emissions conducted below 30 MHz (AC conducted)	± 2.6 dB	

9 Summary of measurement results

<input checked="" type="checkbox"/>	No deviations from the technical specifications were ascertained
<input type="checkbox"/>	There were deviations from the technical specifications ascertained
<input checked="" type="checkbox"/>	This test report is only a partial test report. The content and verdict of the performed test cases are listed below.

TC Identifier	Description	Verdict	Date	Remark
RF-Testing	CFR Title 47 Part 15 RSS 247, Issue 2	See table	2020-02-19	-/-

Test specification clause	Test case	C	NC	NA	NP	Remark
-/-	Output power verification (cond.)	-/-				Declared
-/-	Antenna gain	-/-				-/-
U-NII Part 15	Duty cycle	-/-				-/-
§15.407(a) RSS - 247 (6.2.x.1)	Maximum output power (conducted & radiated)	<input checked="" type="checkbox"/>	<input type="checkbox"/>	<input type="checkbox"/>	<input type="checkbox"/>	-/-
§15.407(a) RSS - 247 (6.2.x.1)	Power spectral density	<input checked="" type="checkbox"/>	<input type="checkbox"/>	<input type="checkbox"/>	<input type="checkbox"/>	-/-
RSS - 247 (6.2.4.1)	Spectrum bandwidth 6dB bandwidth	<input checked="" type="checkbox"/>	<input type="checkbox"/>	<input type="checkbox"/>	<input type="checkbox"/>	-/-
§15.407(a) RSS - 247 (6.2.x.2)	Spectrum bandwidth 26dB bandwidth	<input checked="" type="checkbox"/>	<input type="checkbox"/>	<input type="checkbox"/>	<input type="checkbox"/>	-/-
RSS Gen clause 6.6	Spectrum bandwidth 99% bandwidth	-/-				-/-
§15.205 RSS - 247 (6.2.x.2)	Band edge compliance radiated	<input checked="" type="checkbox"/>	<input type="checkbox"/>	<input type="checkbox"/>	<input type="checkbox"/>	-/-
§15.407(b) RSS - 247 (6.2.x.2)	TX spurious emissions radiated	<input checked="" type="checkbox"/>	<input type="checkbox"/>	<input type="checkbox"/>	<input type="checkbox"/>	-/-
§15.109 RSS-Gen	RX spurious emissions radiated	<input checked="" type="checkbox"/>	<input type="checkbox"/>	<input type="checkbox"/>	<input type="checkbox"/>	-/-
§15.209(a) RSS-Gen	Spurious emissions radiated < 30 MHz	<input checked="" type="checkbox"/>	<input type="checkbox"/>	<input type="checkbox"/>	<input type="checkbox"/>	-/-
§15.107(a) §15.207	Spurious emissions conducted emissions < 30 MHz	<input checked="" type="checkbox"/>	<input type="checkbox"/>	<input type="checkbox"/>	<input type="checkbox"/>	-/-
§15.407 RSS - 247 (6.3)	DFS	-/-				See report 1-9148/19-01-05

Notes:

C:	Compliant	NC:	Not compliant	NA:	Not applicable	NP:	Not performed
-----------	-----------	------------	---------------	------------	----------------	------------	---------------

10 Additional comments

Reference documents: DFS report: 1-9148/19-01-05
ICO-OPE-03994 Wifi_labtool_Radio_agreement_procedure.pdf
1-9148_19-01-04_Annex_MR_A_1.pdf

Special test descriptions: None

Configuration descriptions: Used power settings for all tests: a-mode: 14
n HT20-mode: 13
n HT40-mode: 11

EUT selection: Only one device available
 Devices selected by the customer
 Devices selected by the laboratory (Randomly)

Provided channels:

Channels with 20 MHz channel bandwidth:

U-NII-1 & U-NII-2A (5150 MHz to 5250 MHz & 5250 MHz to 5350 MHz) channel number & center frequency								
channel	36	40	44	48	52	56	60	64
f _c / MHz	5180	5200	5220	5240	5260	5280	5300	5320

U-NII-2C (5470 MHz to 5725 MHz) channel number & center frequency											
channel	100	104	108	112	116	120	124	128	132	136	140
f _c / MHz	5500	5520	5540	5560	5580	5600	5620	5640	5660	5680	5700

U-NII-3 (5725 MHz to 5850 MHz) channel number & center frequency					
channel	149	153	157	161	165
f _c / MHz	5745	5765	5785	5805	5825

Channels with 40 MHz channel bandwidth:

U-NII-1 & U-NII-2A (5150 MHz to 5250 MHz & 5250 MHz to 5350 MHz) channel number & center frequency				
channel	38	46	54	62
f _c / MHz	5190	5230	5270	5310

U-NII-2C (5470 MHz to 5725 MHz) channel number & center frequency				
channel	102	110	118	134
f _c / MHz	5510	5550	5590	5670

U-NII-3 (5725 MHz to 5850 MHz) channel number & center frequency		
channel	151	159
f _c / MHz	5755	5795

Note: The channels used for the tests were marked in bold in the list.

Test mode:

- No test mode available.
Iperf is used to transmit data to a companion device
- Special software is used.
EUT is transmitting pseudo random data by itself

Antennas and transmit operating modes:

- Operating mode 1 (single antenna)
 - Equipment with 1 antenna,
 - Equipment with 2 diversity antennas operating in switched diversity mode by which at any moment in time only 1 antenna is used,
 - Smart antenna system with 2 or more transmit/receive chains, but operating in a mode where only 1 transmit/receive chain is used)
- Operating mode 2 (multiple antennas, no beamforming)
 - Equipment operating in this mode contains a smart antenna system using two or more transmit/receive chains simultaneously but without beamforming.
- Operating mode 3 (multiple antennas, with beamforming)
 - Equipment operating in this mode contains a smart antenna system using two or more transmit/receive chains simultaneously with beamforming.
In addition to the antenna assembly gain (G), the beamforming gain (Y) may have to be taken into account when performing the measurements.

11 Measurement results

11.1 Identify worst case data rate

Measurement:

All modes of the module will be measured with an average power meter to identify the maximum transmission power on mid channel. In the case that only one or two channels are available, only these will be measured.

In further tests only the identified worst case modulation scheme or bandwidth will be measured.

Measurement parameters:

Measurement parameter	
Detector:	Peak
Sweep time:	Auto
Resolution bandwidth:	3 MHz
Video bandwidth:	3 MHz
Trace mode:	Max hold
Used test setup:	See chapter 6.4 – A
Measurement uncertainty:	See chapter 8

Results:

OFDM – mode	Modulation scheme / bandwidth					
	U-NII-1 & U-NII-2A		U-NII-2C		U-NII-3	
	lowest channel	highest channel	lowest channel	highest channel	lowest channel	highest channel
a – mode	6 Mbit/s	6 Mbit/s	6 Mbit/s	6 Mbit/s	6 Mbit/s	6 Mbit/s
n HT20 – mode	MCS0	MCS0	MCS0	MCS0	MCS0	MCS0
n HT40 – mode	MCS0	MCS0	MCS0	MCS0	MCS0	MCS0

11.2 Antenna gain

Description:

The antenna gain of the complete system is calculated by the difference of radiated power in EIRP and the conducted power of the module.

Measurement parameters:

Measurement parameter	
External result file(s)	1-9148_19-01-04_Annex_MR_A_1.pdf Peak OP 3MHz/3MHz
Test setup:	See chapter 6.6 – A (radiated) See chapter 6.4 – A (conducted)
Measurement uncertainty:	See chapter 8

Limits:

Antenna Gain
6 dBi / > 6 dBi output power and power density reduction required

Results:

U-NII-1 (5150 MHz to 5250 MHz)	Antenna gain		
	Lowest channel	Middle channel	Highest channel
Conducted power / dBm @ 3 MHz RBW	5.7	-/-	6.5
Radiated power / dBm @ 3 MHz RBW	2.9	-/-	1.5
Gain / dBi (calculated or declared)	-2.8	-/-	-5.0

U-NII-2A (5250 MHz to 5350 MHz)	Antenna gain		
	Lowest channel	Middle channel	Highest channel
Conducted power / dBm @ 3 MHz RBW	4.5	-/-	3.6
Radiated power / dBm @ 3 MHz RBW	1.7	-/-	0.2
Gain / dBi (calculated or declared)	-2.8	-/-	-3.4

U-NII-2C (5470 MHz to 5725 MHz)	Antenna gain		
	Lowest channel	Middle channel	Highest channel
Conducted power / dBm @ 3 MHz RBW	4.6	4.0	6.5
Radiated power / dBm @ 3 MHz RBW	1.1	1.4	1.0
Gain / dBi (calculated or declared)	-3.5	-2.6	-5.5

U-NII-3 (5725 MHz to 5850 MHz)	Antenna gain		
	Lowest channel	Middle channel	Highest channel
Conducted power / dBm @ 3 MHz RBW	9.3	9.6	9.6
Radiated power / dBm @ 3 MHz RBW	1.0	1.7	2.9
Gain / dBi (calculated or declared)	-8.3	-7.9	-6.7

11.3 Duty cycle

Description:

The duty cycle is necessary to compute the maximum power during an actual transmission. The shown plots and values are to show an example of the measurement procedure. The real value is measured direct during the power measurement or power density measurement. The correction value is shown in each plot of these measurements.

Measurement:

Measurement parameter	
According to: KDB789033 D02, B.	
External result file(s)	1-9148_19-01-04_Annex_MR_A_1.pdf FCC Part 15.407 Max Output Power and PSD
Used test setup:	See chapter 6.4 – A
Measurement uncertainty:	See chapter 8

Results:

Duty cycle and correction factor:

a – mode	100%	0.0 dB
n HT20 – mode	100%	0.0 dB
n HT40 – mode	100%	0.0 dB

11.4 Maximum output power

11.4.1 Maximum output power according to FCC requirements

Description:

Measurement of the maximum output power conducted

Measurement:

Measurement parameter	
According to: KDB789033 D02, E.2.e.	
External result file(s)	1-9148_19-01-04_Annex_MR_A_1.pdf FCC Part 15.407 Max Output Power and PSD
Used test setup:	See chapter 6.4 – A
Measurement uncertainty:	See chapter 8

Limits:

Radiated output power	Conducted output power for mobile equipment
Conducted power + 6 dBi antenna gain	250mW 5.150-5.250 GHz The lesser one of 250mW or 11 dBm + 10 log Bandwidth 5.250-5.350 GHz 250mW or 11 dBm + 10 log Bandwidth 5.470-5.725 GHz (where Bandwidth is the 26dB Bandwidth [MHz]) 1W 5.725-5.85 GHz

Results:

a	Maximum output power conducted [dBm]		
	U-NII-1 (5150 MHz to 5250 MHz)		
	Lowest channel	Middle channel	Highest channel
	4.8	4.7	4.5
	U-NII-2A (5250 MHz to 5350 MHz)		
	Lowest channel	Middle channel	Highest channel
	2.8	4.4	1.8
	U-NII-2C (5470 MHz to 5725 MHz)		
	Lowest channel	Middle channel	Highest channel
	3.1	2.4	4.7
	U-NII-3 (5725 MHz to 5850 MHz)		
	Lowest channel	Middle channel	Highest channel
7.6	8.8	8.8	

Results:

n HT20	Maximum output power conducted [dBm]		
	U-NII-1 (5150 MHz to 5250 MHz)		
	Lowest channel	Middle channel	Highest channel
	4.8	4.3	4.1
	U-NII-2A (5250 MHz to 5350 MHz)		
	Lowest channel	Middle channel	Highest channel
	1.9	3.3	1.0
	U-NII-2C (5470 MHz to 5725 MHz)		
	Lowest channel	Middle channel	Highest channel
	2.2	1.4	3.9
	U-NII-3 (5725 MHz to 5850 MHz)		
	Lowest channel	Middle channel	Highest channel
6.7	8.2	8.3	

Results:

n HT40	Maximum output power conducted [dBm]		
	U-NII-1 (5150 MHz to 5250 MHz)		
	Lowest channel		Highest channel
	1.6		1.2
	U-NII-2A (5250 MHz to 5350 MHz)		
	Lowest channel		Highest channel
	0.5		-0.4
	U-NII-2C (5470 MHz to 5725 MHz)		
	Lowest channel	Middle channel	Highest channel
	-0.2	-0.7	0.9
	U-NII-3 (5725 MHz to 5850 MHz)		
	Lowest channel		Highest channel
	3.3		5.6

11.4.2 Maximum output power according to IC requirements

Description:

Measurement of the maximum output power conducted + radiated

Measurement:

Measurement parameter	
External result file(s)	1-9148_19-01-04_Annex_MR_A_1.pdf ISED Max Output Power and PSD
Used test setup:	See chapter 6.4 – A
Measurement uncertainty:	See chapter 8

Limits:

Radiated output power	Conducted output power for mobile equipment
The lesser one of 200 mW or 10 dBm + 10 log Bandwidth 5.150-5.250 GHz 1 W or 17 dBm + 10 log Bandwidth 5.250-5.350 GHz 1 W or 17 dBm + 10 log Bandwidth 5.470-5.725 GHz (where Bandwidth is the 99% Bandwidth [MHz]) Conducted power + 6dBi antenna gain 5.725-5.825 GHz	The lesser one of 250mW or 11 dBm + 10 log Bandwidth 5.250-5.350 GHz 250mW or 11 dBm + 10 log Bandwidth 5.470-5.725 GHz (where Bandwidth is the 99% Bandwidth [MHz]) 1W 5.725-5.825 GHz

Results:

a	Maximum output power [dBm]		
	U-NII-1 (5150 MHz to 5250 MHz)		
	Lowest channel	Middle channel	Highest channel
	Conducted		
	4.8	4.6	4.4
	Radiated (calculated – see chapter antenna gain)		
	2.0	1.8	-0.6
	U-NII-2A (5250 MHz to 5350 MHz)		
	Lowest channel	Middle channel	Highest channel
	Conducted		
	2.8	4.3	1.9
	Radiated (calculated – see chapter antenna gain)		
	0.0	1.5	-1.5
	U-NII-2C (5470 MHz to 5725 MHz)		
	Lowest channel	Middle channel	Highest channel
	Conducted		
	3.1	2.3	4.6
	Radiated (calculated – see chapter antenna gain)		
	-0.4	-0.3	-0.9
	U-NII-3 (5725 MHz to 5850 MHz)		
	Lowest channel	Middle channel	Highest channel
Conducted			
7.6	8.8	8.7	
Radiated (calculated – see chapter antenna gain)			
0.7	0.9	2.0	

Results:

n HT20	Maximum output power [dBm]		
	U-NII-1 (5150 MHz to 5250 MHz)		
	Lowest channel	Middle channel	Highest channel
	Conducted		
	4.6	4.1	3.9
	Radiated (calculated – see chapter antenna gain)		
	1.8	1.3	-1.1
	U-NII-2A (5250 MHz to 5350 MHz)		
	Lowest channel	Middle channel	Highest channel
	Conducted		
	1.8	3.2	0.9
	Radiated (calculated – see chapter antenna gain)		
	-1.0	0.4	-2.5
	U-NII-2C (5470 MHz to 5725 MHz)		
	Lowest channel	Middle channel	Highest channel
	Conducted		
	2.1	1.3	3.7
	Radiated (calculated – see chapter antenna gain)		
	-1.4	-1.3	-1.8
	U-NII-3 (5725 MHz to 5850 MHz)		
Lowest channel	Middle channel	Highest channel	
Conducted			
6.7	8.1	8.2	
Radiated (calculated – see chapter antenna gain)			
-2.6	0.2	1.5	

Results:

n HT40	Maximum output power [dBm]		
	U-NII-1 (5150 MHz to 5250 MHz)		
	Lowest channel		Highest channel
	Conducted		
	1.6		1.4
	Radiated (calculated – see chapter antenna gain)		
	-1.2		-3.6
	U-NII-2A (5250 MHz to 5350 MHz)		
	Lowest channel		Highest channel
	Conducted		
	0.5		-0.4
	Radiated (calculated – see chapter antenna gain)		
	-2.3		-3.8
	U-NII-2C (5470 MHz to 5725 MHz)		
	Lowest channel	Middle channel	Highest channel
	Conducted		
	-0.2	-0.7	0.9
	Radiated (calculated – see chapter antenna gain)		
	-3.7	-3.3	-4.6
	U-NII-3 (5725 MHz to 5850 MHz)		
Lowest channel		Highest channel	
Conducted			
3.3		5.6	
Radiated (calculated – see chapter antenna gain)			
-5.0		-1.1	

11.5 Power spectral density

11.5.1 Power spectral density according to FCC requirements

Description:

Measurement of the power spectral density of a digital modulated system. The measurement is repeated at the lowest, middle and highest channel.

Measurement:

Measurement parameter	
According to: KDB789033 D02, F.	
External result file(s)	1-9148_19-01-04_Annex_MR_A_1.pdf FCC Part 15.407 Max Output Power and PSD
Used test setup:	See chapter 6.4 – A
Measurement uncertainty:	See chapter 8

Limits:

Power Spectral Density
power spectral density conducted ≤ 11 dBm in any 1 MHz band (band 5150 – 5250 MHz)
power spectral density conducted ≤ 11 dBm in any 1 MHz band (band 5250 – 5350 MHz)
power spectral density conducted ≤ 11 dBm in any 1 MHz band (band 5470 – 5725 MHz)
power spectral density conducted ≤ 30 dBm in any 500 kHz band (band 5725 – 5850 MHz)

Results:

a	Power spectral density (dBm/1MHz or dBm/500kHz)		
	U-NII-1 (5150 MHz to 5250 MHz)		
	Lowest channel	Middle channel	Highest channel
	-6.8	-6.9	-6.9
	U-NII-2A (5250 MHz to 5350 MHz)		
	Lowest channel	Middle channel	Highest channel
	-8.5	-6.5	-9.7
	U-NII-2C (5470 MHz to 5725 MHz)		
	Lowest channel	Middle channel	Highest channel
	-8.6	-9.3	-6.8
	U-NII-3 (5725 MHz to 5850 MHz)		
	Lowest channel	Middle channel	Highest channel
	-6.4	-5.3	-5.8

Results:

n HT20	Power spectral density (dBm/1MHz or dBm/500kHz)		
	U-NII-1 (5150 MHz to 5250 MHz)		
	Lowest channel	Middle channel	Highest channel
	-7.0	-7.6	-7.6
	U-NII-2A (5250 MHz to 5350 MHz)		
	Lowest channel	Middle channel	Highest channel
	-9.9	-8.1	-10.7
	U-NII-2C (5470 MHz to 5725 MHz)		
	Lowest channel	Middle channel	Highest channel
	-9.8	-10.6	-7.6
	U-NII-3 (5725 MHz to 5850 MHz)		
	Lowest channel	Middle channel	Highest channel
	-7.1	-6.1	-6.6

Results:

n HT40	Power spectral density (dBm/1MHz or dBm/500kHz)		
	U-NII-1 (5150 MHz to 5250 MHz)		
	Lowest channel		Highest channel
	-13.1		-13.0
	U-NII-2A (5250 MHz to 5350 MHz)		
	Lowest channel		Highest channel
	-13.4		-14.2
	U-NII-2C (5470 MHz to 5725 MHz)		
	Lowest channel	Middle channel	Highest channel
	-15.3	-15.3	-14.2
	U-NII-3 (5725 MHz to 5850 MHz)		
	Lowest channel		Highest channel
	-13.3		-11.8

11.5.2 Power spectral density according to IC requirements

Description:

Measurement of the power spectral density of a digital modulated system. The measurement is repeated at the lowest, middle and highest channel.

Measurement:

Measurement parameter	
External result file(s)	1-9148_19-01-04_Annex_MR_A_1.pdf ISED Max Output Power and PSD
Used test setup:	See chapter 6.4 – A
Measurement uncertainty:	See chapter 8

Limits:

Power Spectral Density
power spectral density e.i.r.p. ≤ 10 dBm in any 1 MHz band (band 5150 – 5250 MHz)
power spectral density conducted ≤ 11 dBm in any 1 MHz band (band 5250 – 5350 MHz)
power spectral density conducted ≤ 11 dBm in any 1 MHz band (band 5470 – 5725 MHz)
power spectral density conducted ≤ 30 dBm in any 500 kHz band (band 5725 – 5850 MHz)

Results:

a	Power spectral density (dBm/1MHz or dBm/500kHz)		
	U-NII-1 (5150 MHz to 5250 MHz)		
	Lowest channel	Middle channel	Highest channel
	Conducted		
	-6.4	-6.9	-6.9
	Radiated (calculated – see chapter antenna gain)		
	-9.2	-9.7	-11.9
	U-NII-2A (5250 MHz to 5350 MHz)		
	Lowest channel	Middle channel	Highest channel
	-8.4	-6.7	-9.3
	U-NII-2C (5470 MHz to 5725 MHz)		
	Lowest channel	Middle channel	Highest channel
	-8.6	-9.4	-6.9
	U-NII-3 (5725 MHz to 5850 MHz)		
	Lowest channel	Middle channel	Highest channel
-6.3	-5.4	-5.9	

Results:

n HT20	Power spectral density (dBm/1MHz or dBm/500kHz)		
	U-NII-1 (5150 MHz to 5250 MHz)		
	Lowest channel	Middle channel	Highest channel
	Conducted		
	-7.2	-7.7	-7.7
	Radiated (calculated – see chapter antenna gain)		
	-10.0	-10.5	-12.7
	U-NII-2A (5250 MHz to 5350 MHz)		
	Lowest channel	Middle channel	Highest channel
	-10.0	-8.1	-10.7
	U-NII-2C (5470 MHz to 5725 MHz)		
	Lowest channel	Middle channel	Highest channel
	-9.8	-10.6	-7.8
	U-NII-3 (5725 MHz to 5850 MHz)		
	Lowest channel	Middle channel	Highest channel
-7.5	-6.1	-6.5	

Results:

n HT40	Power spectral density (dBm/1MHz or dBm/500kHz)		
	U-NII-1 (5150 MHz to 5250 MHz)		
	Lowest channel		Highest channel
	Conducted		
	-13.1		-13.0
	Radiated (calculated – see chapter antenna gain)		
	-15.9		-18.0
	U-NII-2A (5250 MHz to 5350 MHz)		
	Lowest channel		Highest channel
	-13.5		-14.2
	U-NII-2C (5470 MHz to 5725 MHz)		
	Lowest channel	Middle channel	Highest channel
	-15.3	-15.4	-14.2
	U-NII-3 (5725 MHz to 5850 MHz)		
	Lowest channel		Highest channel
-13.3		-11.8	

11.6 Minimum emission bandwidth for the band 5.725-5.85 GHz

Description:

Measurement of the 6 dB bandwidth of the modulated signal.

Measurement:

Measurement parameter	
According to: KDB789033 D02, C.2.	
External result file(s)	1-9148_19-01-04_Annex_MR_A_1.pdf FCC Part 15.407 & ISED Minimum Emission BW
Used test setup:	See chapter 6.4 – A
Measurement uncertainty:	See chapter 8

Limits:

FCC	IC
The minimum 6 dB bandwidth shall be at least 500 kHz.	

Results:

a	6 dB emission bandwidth (MHz)		
	U-NII-3 (5725 MHz to 5850 MHz)		
	Lowest channel	Middle channel	Highest channel
	16.5	16.5	16.5

Results:

n HT20	6 dB emission bandwidth (MHz)		
	U-NII-3 (5725 MHz to 5850 MHz)		
	Lowest channel	Middle channel	Highest channel
	17.7	17.7	17.9

Results:

n HT40	6 dB emission bandwidth (MHz)	
	U-NII-3 (5725 MHz to 5850 MHz)	
	Lowest channel	Highest channel
	36.4	36.4

11.7 Spectrum bandwidth / 26 dB bandwidth

Description:

Measurement of the 26 dB bandwidth of the modulated signal.

Measurement:

Measurement parameter	
According to: KDB789033 D02, C.1.	
External result file(s)	1-9148_19-01-04_Annex_MR_A_1.pdf FCC Part 15.407 & ISED Bandwidths
Used test setup:	see chapter 6.4 – A
Measurement uncertainty:	See chapter 8

Limits:

Spectrum Bandwidth – 26 dB Bandwidth
<p>IC: Any unwanted emissions that fall into the band 5250-5350 MHz shall be attenuated below the channel power by at least 26 dB, when measured using a resolution bandwidth between 1 and 5% of the occupied bandwidth (i.e. 99% bandwidth), above 5250 MHz. The 26 dB bandwidth may fall into the 5250-5350 MHz band; however, if the occupied bandwidth also falls within the 5250-5350 MHz band, the transmission is considered as intentional and the devices shall comply with all requirements in the band 5250-5350 MHz including implementing dynamic frequency selection (DFS) and TPC, on the portion of the emission that resides in the 5250-5350 MHz band.</p> <p>FCC: Radar Detection Function of Dynamic Frequency Selection (DFS). U-NII devices operating with any part of its 26 dB emission bandwidth in the 5.25-5.35 GHz and 5.47-5.725 GHz bands shall employ a DFS radar detection mechanism to detect the presence of radar systems and to avoid co-channel operation with radar systems.</p> <p>According to 789033 D02 General U-NII Test Procedures New Rules v02r01 the 99% bandwidth may be used in lieu of the 26 dB bandwidth. The DFS radar detection mechanism on Channel 48 (5240 MHz) is only required when the 99% bandwidth also falls in the 5.25-5.35 GHz band.</p>

Results:

a	26 dB bandwidth (MHz)		
	U-NII-1 (5150 MHz to 5250 MHz)		
	Lowest channel	Middle channel	Highest channel
	20.2	20.2	20.1
	Lowest frequency		Highest frequency
	5170.0		5249.95
	U-NII-2A (5250 MHz to 5350 MHz)		
	Lowest channel	Middle channel	Highest channel
	20.3	20.0	20.2
	U-NII-2C (5470 MHz to 5725 MHz)		
	Lowest channel	Middle channel	Highest channel
	20.0	20.2	34.9
	U-NII-3 (5725 MHz to 5850 MHz)		
	Lowest channel	Middle channel	Highest channel
	37.0	41.2	48.1
Lowest frequency		Highest frequency	
5726.3		5849.75	

Results:

n HT20	26 dB bandwidth (MHz)		
	U-NII-1 (5150 MHz to 5250 MHz)		
	Lowest channel	Middle channel	Highest channel
	20.4	20.5	20.4
	Lowest frequency		Highest frequency
	5170.0		5250.1
	U-NII-2A (5250 MHz to 5350 MHz)		
	Lowest channel	Middle channel	Highest channel
	20.6	20.4	20.7
	U-NII-2C (5470 MHz to 5725 MHz)		
	Lowest channel	Middle channel	Highest channel
	20.5	20.6	31.2
	U-NII-3 (5725 MHz to 5850 MHz)		
	Lowest channel	Middle channel	Highest channel
	36.6	42.3	49.8
Lowest frequency		Highest frequency	
5726.6		5849.8	

Results:

n HT40	26 dB bandwidth (MHz)		
	U-NII-1 (5150 MHz to 5250 MHz)		
	Lowest channel		Highest channel
	42.3		41.2
	Lowest frequency		Highest frequency
	5168.4		5250.5
	U-NII-2A (5250 MHz to 5350 MHz)		
	Lowest channel		Highest channel
	41.3		41.4
	U-NII-2C (5470 MHz to 5725 MHz)		
	Lowest channel	Middle channel	Highest channel
	41.5	41.6	41.7
	U-NII-3 (5725 MHz to 5850 MHz)		
	Lowest channel		Highest channel
	64.9		74.0
	Lowest frequency		Highest frequency
5726.4		5835.6	

11.8 Occupied bandwidth / 99% emission bandwidth

Description:

Measurement of the 99% bandwidth of the modulated signal acc. RSS-GEN.

Measurement:

Measurement parameter	
External result file(s)	1-9148_19-01-04_Annex_MR_A_1.pdf FCC Part 15.407 & ISED Bandwidths
Test setup:	See sub clause 6.5 – B
Measurement uncertainty:	See chapter 8

Usage:

-/-	IC
OBW is necessary for Emission Designator	

Results:

a	99% bandwidth (kHz)		
	U-NII-1 (5150 MHz to 5250 MHz)		
	Lowest channel	Middle channel	Highest channel
	17083	16833	16783
	U-NII-2A (5250 MHz to 5350 MHz)		
	Lowest channel	Middle channel	Highest channel
	16933	16733	16833
	U-NII-2C (5470 MHz to 5725 MHz)		
	Lowest channel	Middle channel	Highest channel
	16733	16833	17682
	U-NII-3 (5725 MHz to 5850 MHz)		
	Lowest channel	Middle channel	Highest channel
19530	27023	33217	

Results:

n HT20	99% bandwidth (kHz)		
	U-NII-1 (5150 MHz to 5250 MHz)		
	Lowest channel	Middle channel	Highest channel
	17932	17932	17832
	U-NII-2A (5250 MHz to 5350 MHz)		
	Lowest channel	Middle channel	Highest channel
	17932	17882	17982
	U-NII-2C (5470 MHz to 5725 MHz)		
	Lowest channel	Middle channel	Highest channel
	17932	18232	18232
	U-NII-3 (5725 MHz to 5850 MHz)		
	Lowest channel	Middle channel	Highest channel
19331	25874	33916	

Results:

n HT40	99% bandwidth (kHz)		
	U-NII-1 (5150 MHz to 5250 MHz)		
	Lowest channel		Highest channel
	36563		36464
	U-NII-2A (5250 MHz to 5350 MHz)		
	Lowest channel		Highest channel
	36763		36863
	U-NII-2C (5470 MHz to 5725 MHz)		
	Lowest channel	Middle channel	Highest channel
	36663	36663	36663
	U-NII-3 (5725 MHz to 5850 MHz)		
	Lowest channel		Highest channel
	37363		37862

11.9 Band edge compliance radiated

Description:

Measurement of the radiated band edge compliance. The EUT is turned in the position that results in the maximum level at the band edge. Then a sweep over the corresponding restricted band is performed. The EUT is set to the lowest channel for the lower restricted band and to the highest channel for the upper restricted band. Measurement distance is 3m.

Measurement:

Measurement parameter	
Detector:	Peak / RMS
Sweep time:	Auto
Resolution bandwidth:	1 MHz
Video bandwidth:	≥ 3 x RBW
Span:	See plots!
Trace mode:	Max Hold
Test setup:	See sub clause 6.2 – A
Measurement uncertainty:	See chapter 8

Limits:

Band Edge Compliance Radiated
In any 100 kHz bandwidth outside the frequency band in which the spread spectrum or digitally modulated intentional radiator is operating, the radio frequency power that is produced by the intentional radiator shall be at least 20 dB below that in the 100 kHz bandwidth within the band that contains the highest level of the desired power, based on either an RF conducted or a radiated measurement. Attenuation below the general limits specified in Section 15.209(a) is not required. In addition, radiated emissions which fall in the restricted bands, as defined in Section 15.205(a), must also comply with the radiated emission limits specified in Section 15.209(a) (see Section 5.205(c)).
74 dBµV/m (peak) 54 dBµV/m (average)

Result:

Scenario	Band Edge Compliance Radiated [dBµV/m]
band edge	< 74 dBµV/m (peak) < 54 dBµV/m (average)

Plots:

Plot 1: lower band edge; U-NII-1; lowest channel; 20 MHz channel bandwidth

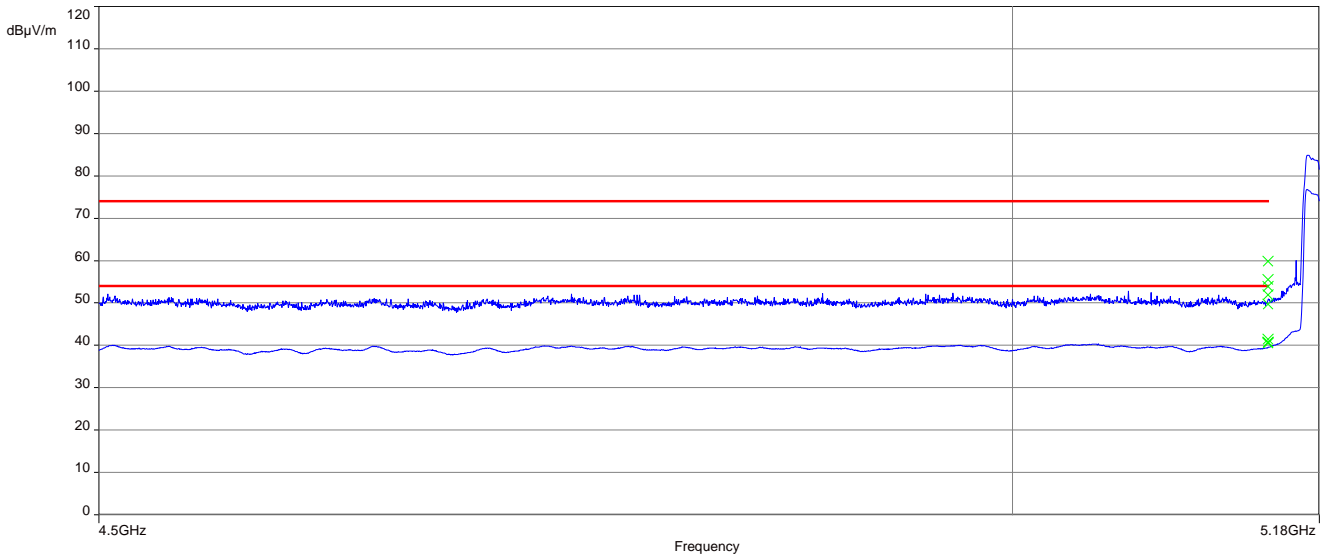

Plot 2: upper band edge; U-NII-2A; highest channel; 20 MHz channel bandwidth

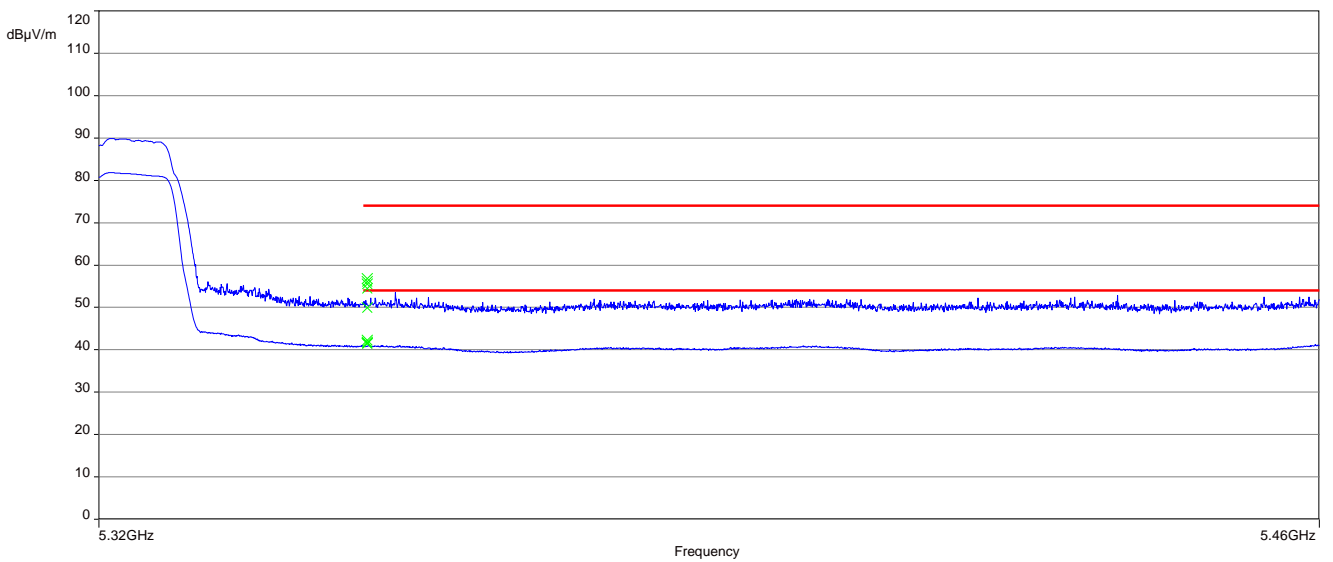

Plot 3: lower band edge; U-NII-2C; lowest channel; 20 MHz channel bandwidth

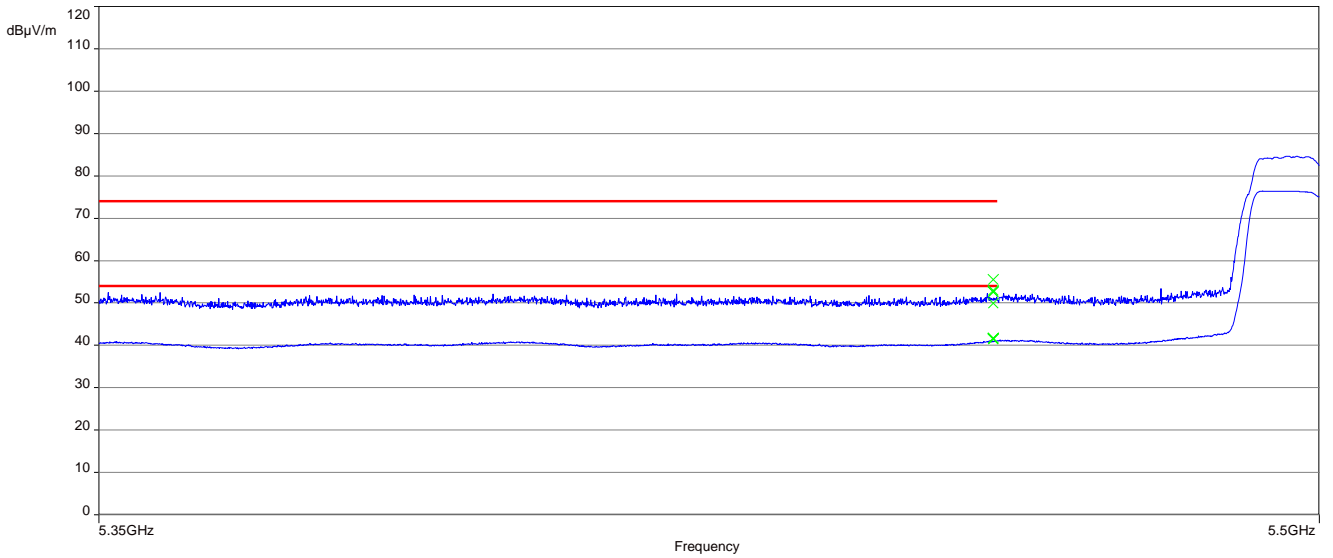

Plot 4: lower band edge; U-NII-1; lowest channel; 40 MHz channel bandwidth

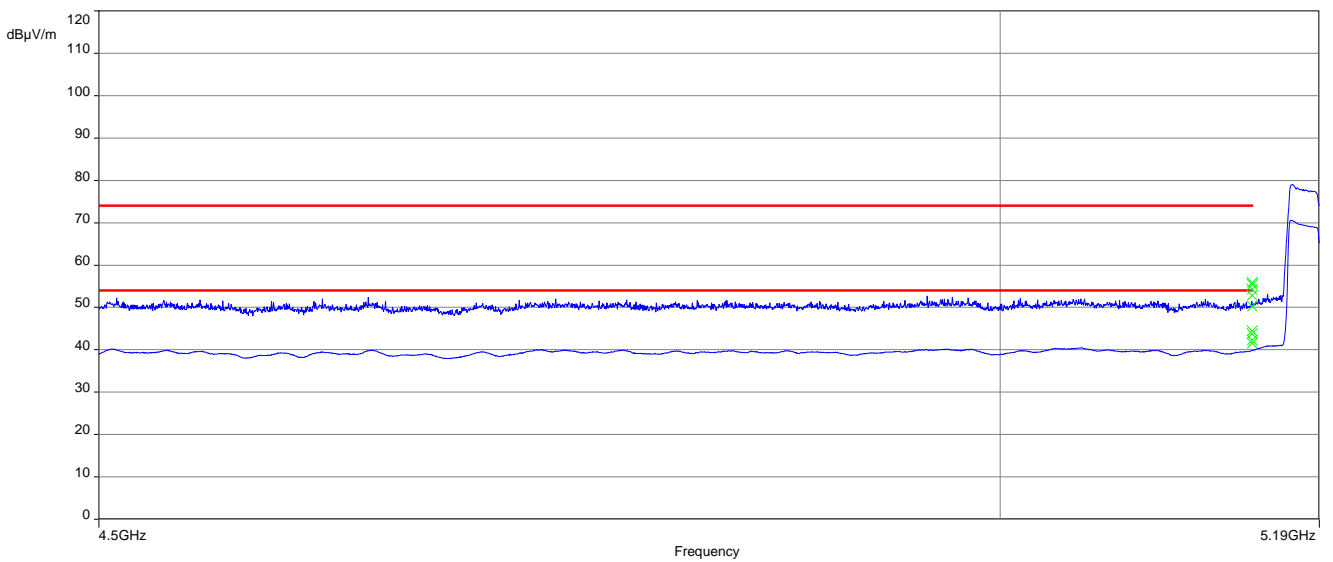

Plot 5: upper band edge; U-NII-2A; highest channel; 40 MHz channel bandwidth

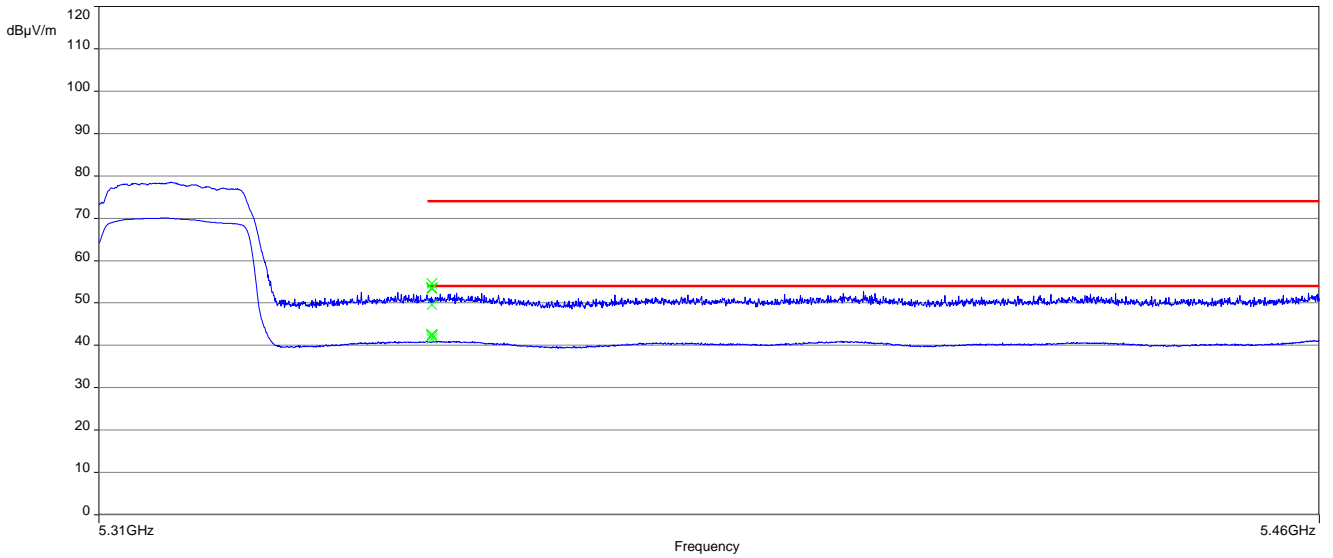

Plot 6: lower band edge; U-NII-2C; lowest channel; 40 MHz channel bandwidth

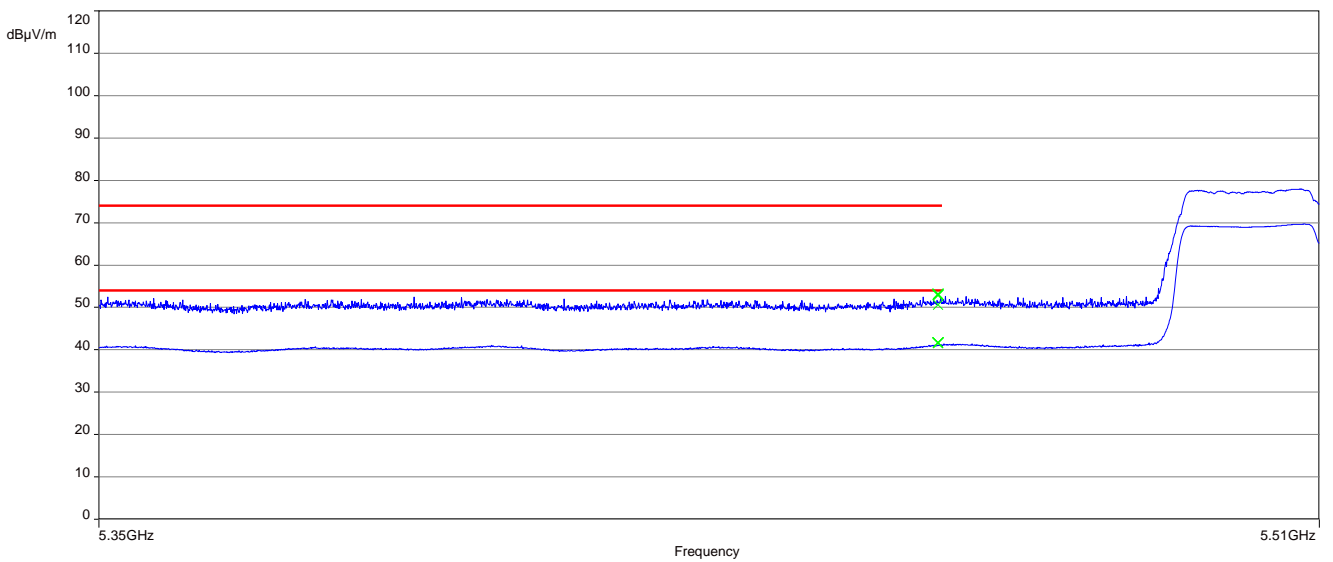

11.10 Spurious emissions radiated below 30 MHz

Description:

Measurement of the radiated spurious emissions in transmit mode below 30 MHz. The limits are re-calculated to a measurement distance of 3 m with 40 dB/decade according CFR Part 2.

Measurement:

Measurement parameter	
Detector:	Peak / Quasi Peak
Sweep time:	Auto
Video bandwidth:	F < 150 kHz: 200 Hz F > 150 kHz: 9 kHz
Resolution bandwidth:	F < 150 kHz: 1 kHz F > 150 kHz: 100 kHz
Span:	9 kHz to 30 MHz
Trace mode:	Max Hold
Test setup:	See sub clause 6.2 – C
Measurement uncertainty:	See chapter 8

Limits:

Spurious Emissions Radiated < 30 MHz		
Frequency (MHz)	Field Strength (dBµV/m)	Measurement distance
0.009 – 0.490	2400/F(kHz)	300
0.490 – 1.705	24000/F(kHz)	30
1.705 – 30.0	30	30

Results:

Spurious Emissions Radiated < 30 MHz [dBµV/m]		
F [MHz]	Detector	Level [dBµV/m]
All detected emissions are more than 20 dB below the limit.		

Plots: 20 MHz channel bandwidth

Plot 1: 9 kHz to 30 MHz, U-NII-1; lowest channel

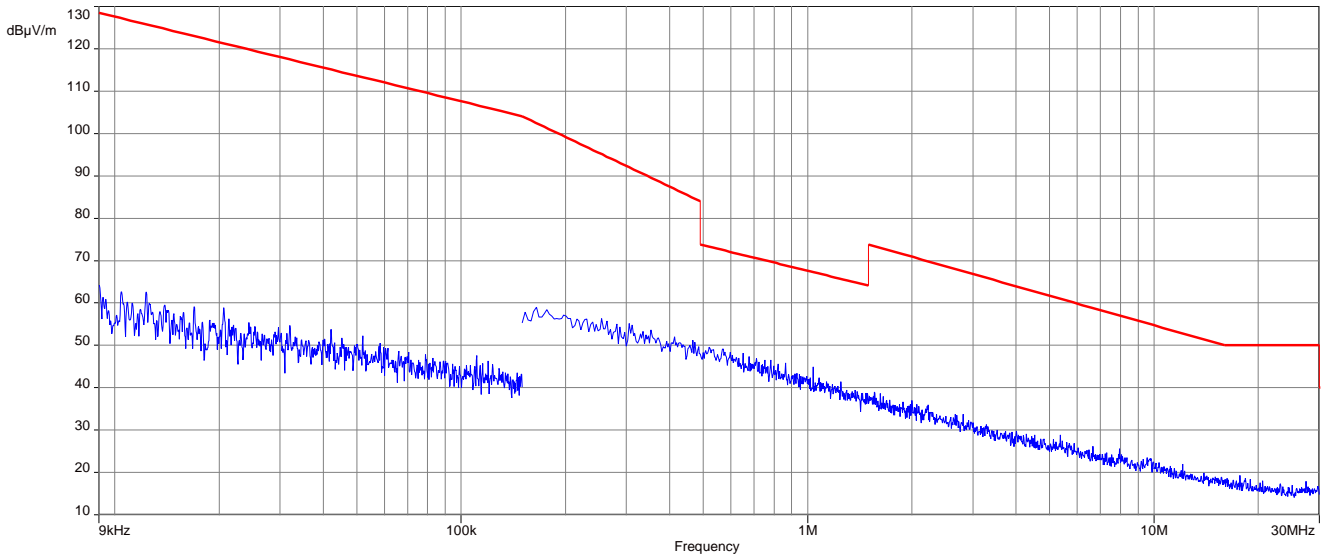

Plot 2: 9 kHz to 30 MHz, U-NII-1; highest channel

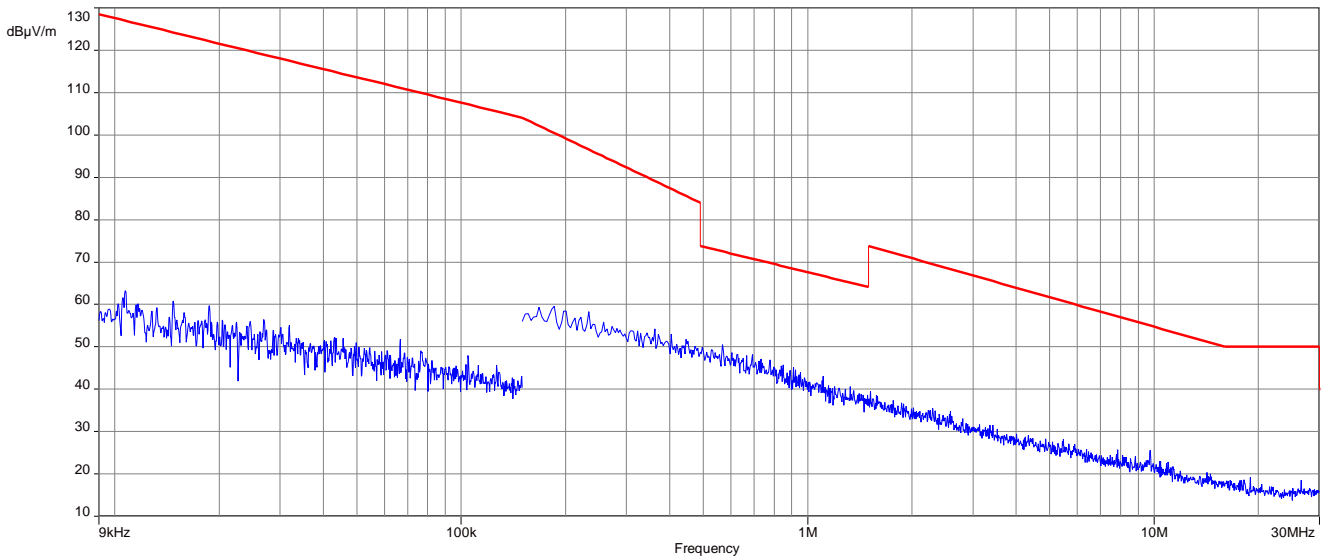

Plot 3: 9 kHz to 30 MHz, U-NII-2A; lowest channel

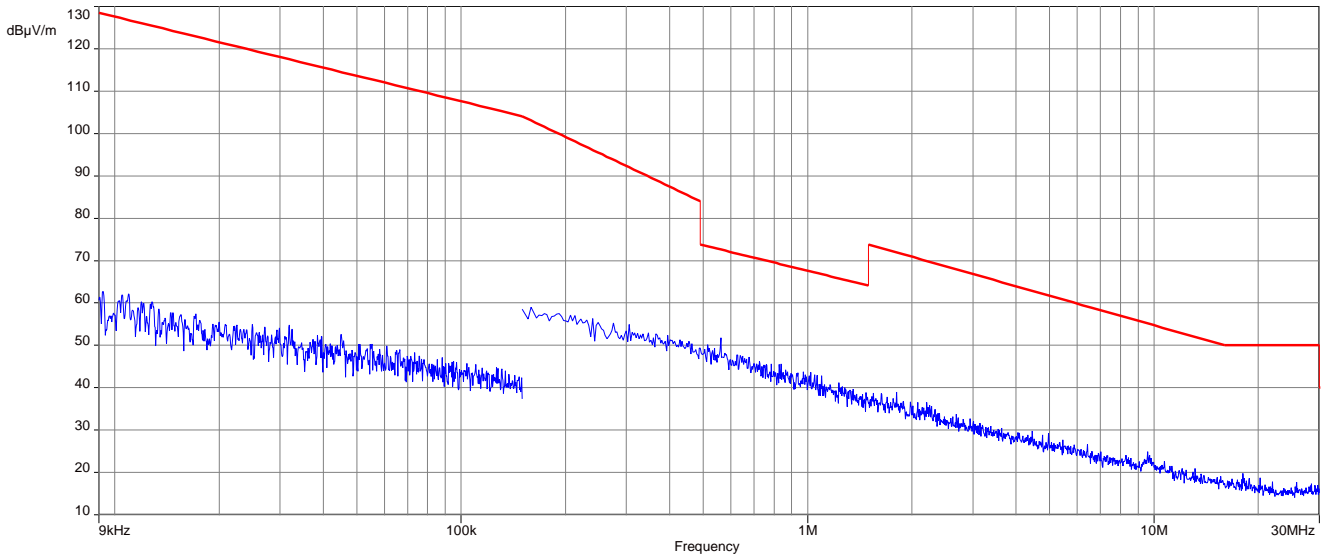

Plot 4: 9 kHz to 30 MHz, U-NII-2A; highest channel

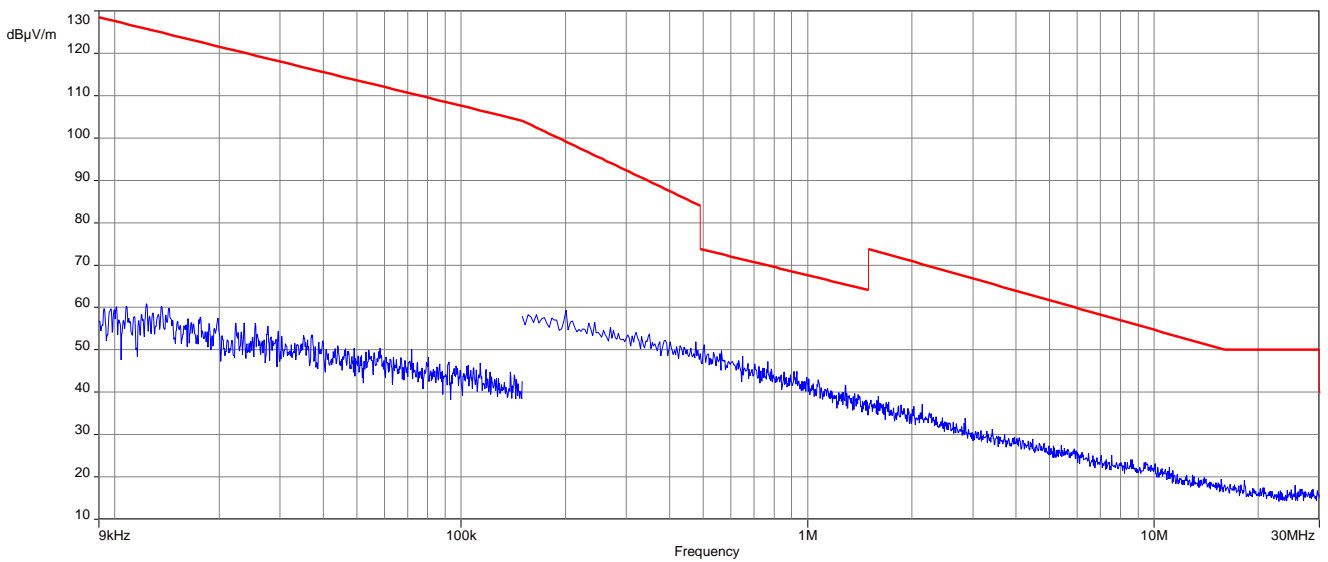

Plot 5: 9 kHz to 30 MHz, U-NII-2C; lowest channel

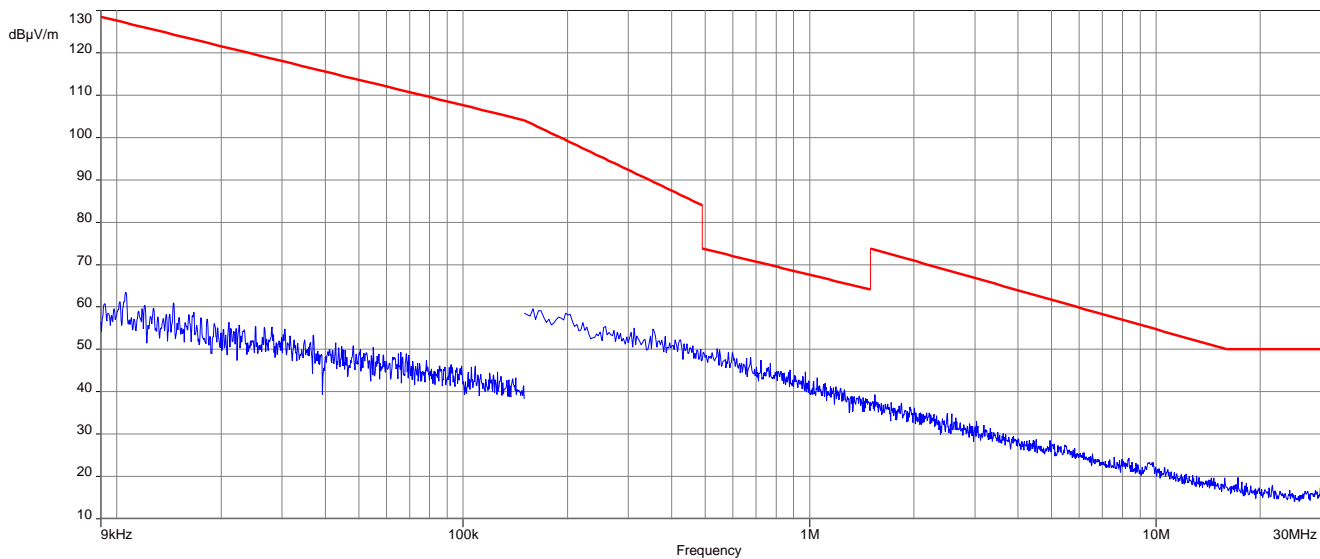

Plot 6: 9 kHz to 30 MHz, U-NII-2C; middle channel

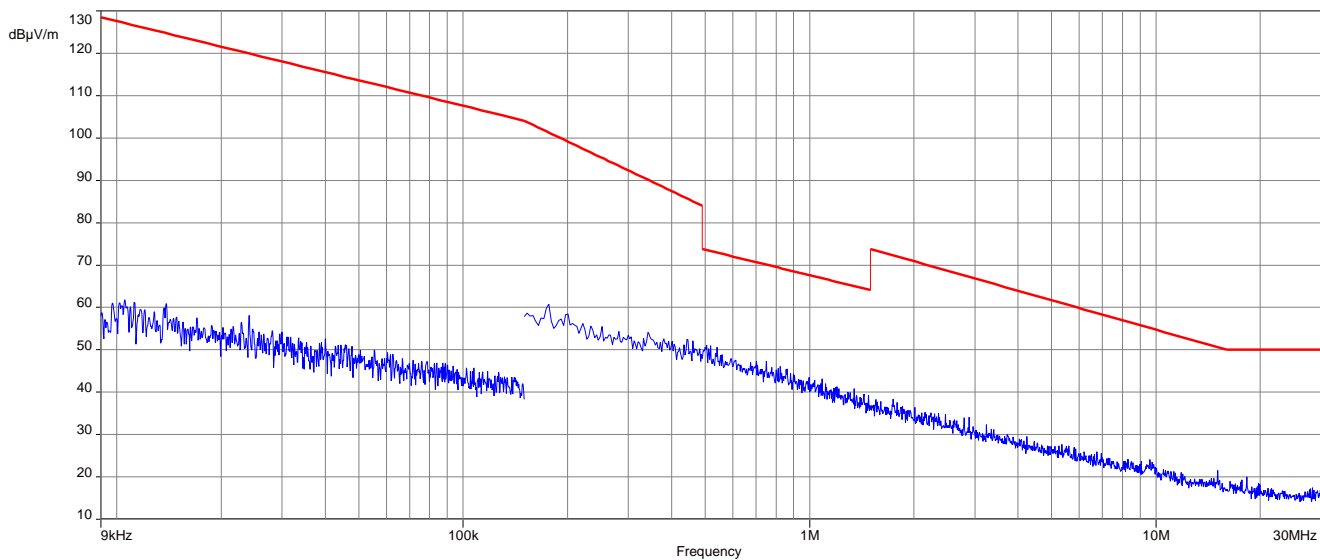

Plot 7: 9 kHz to 30 MHz, U-NII-2C; highest channel

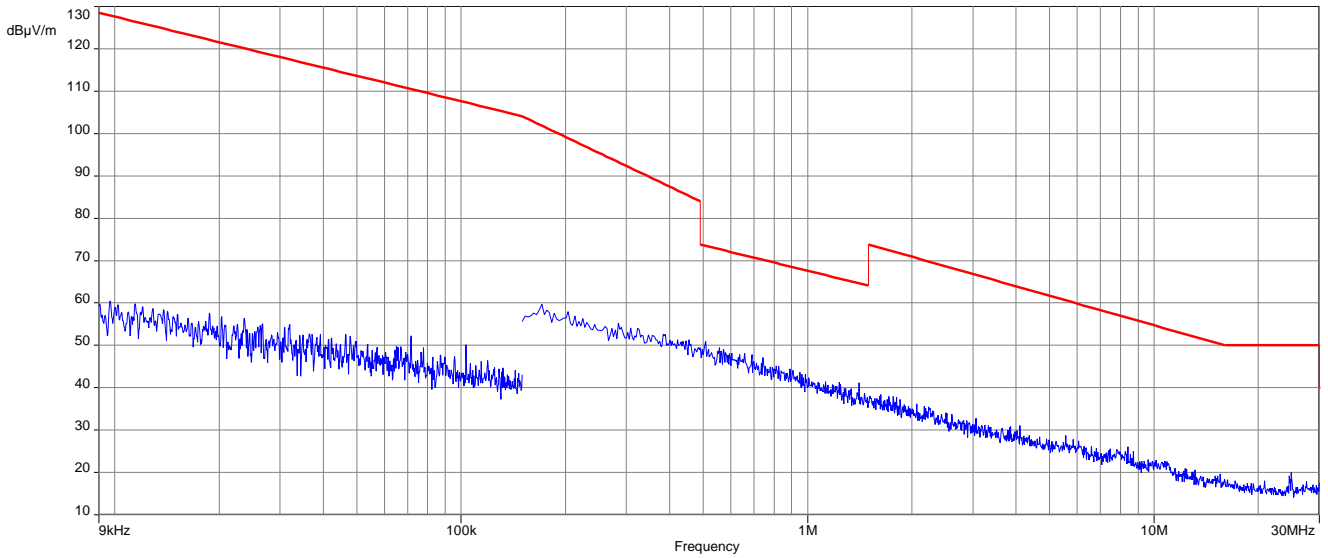

Plot 8: 9 kHz to 30 MHz, U-NII-3; lowest channel

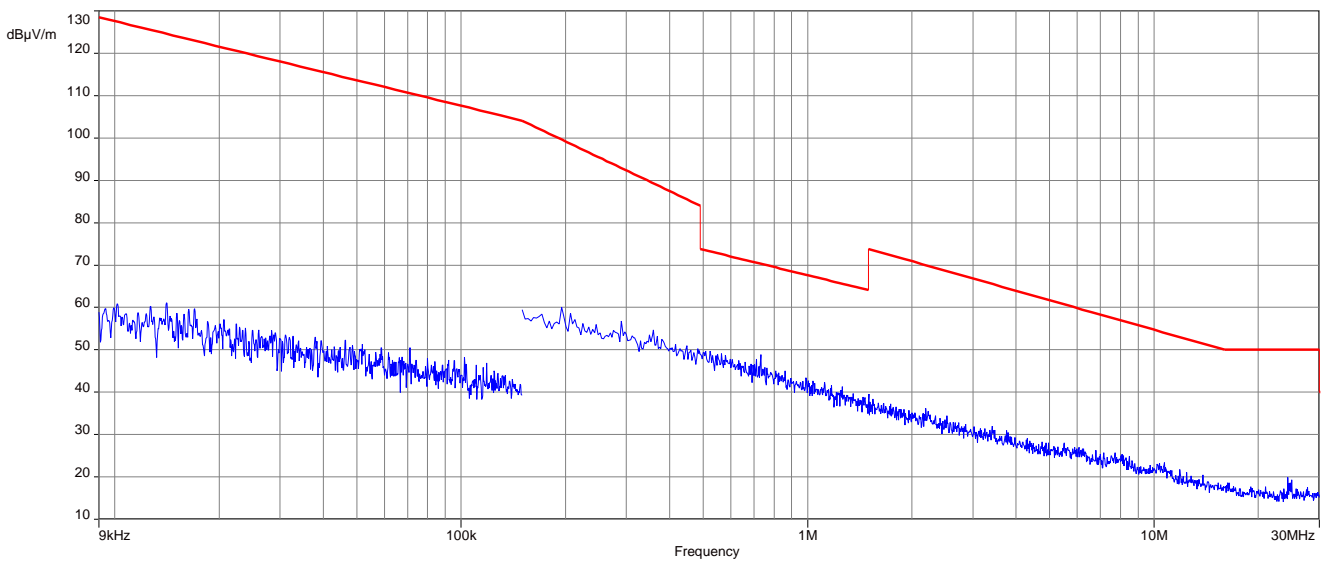

Plot 9: 9 kHz to 30 MHz, U-NII-3; middle channel

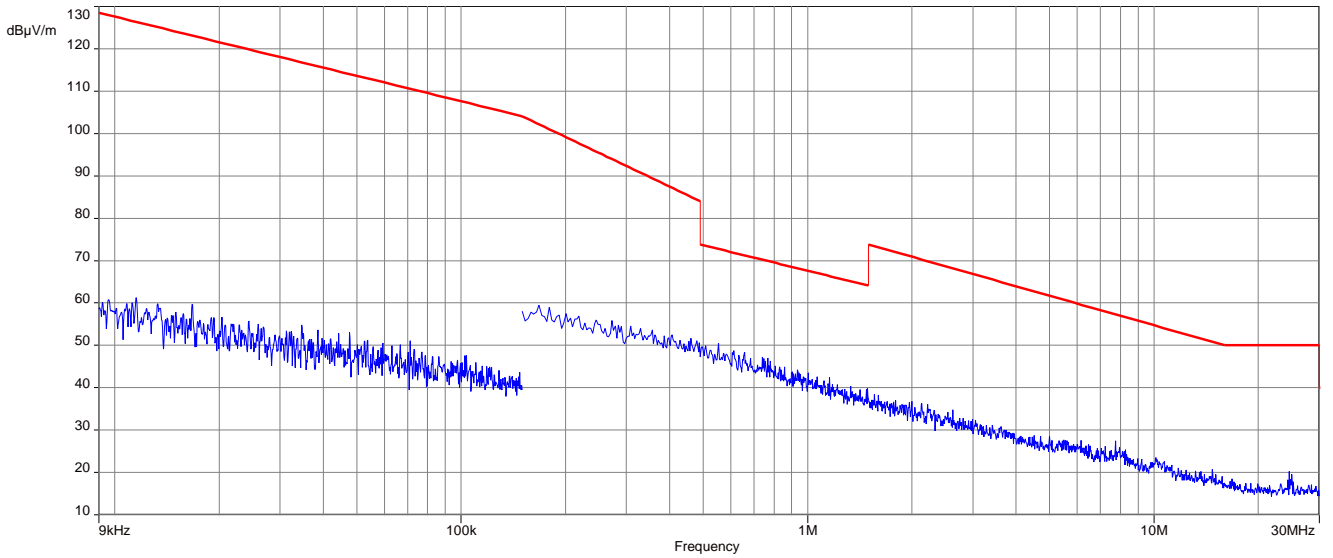

Plot 10: 9 kHz to 30 MHz, U-NII-3; highest channel

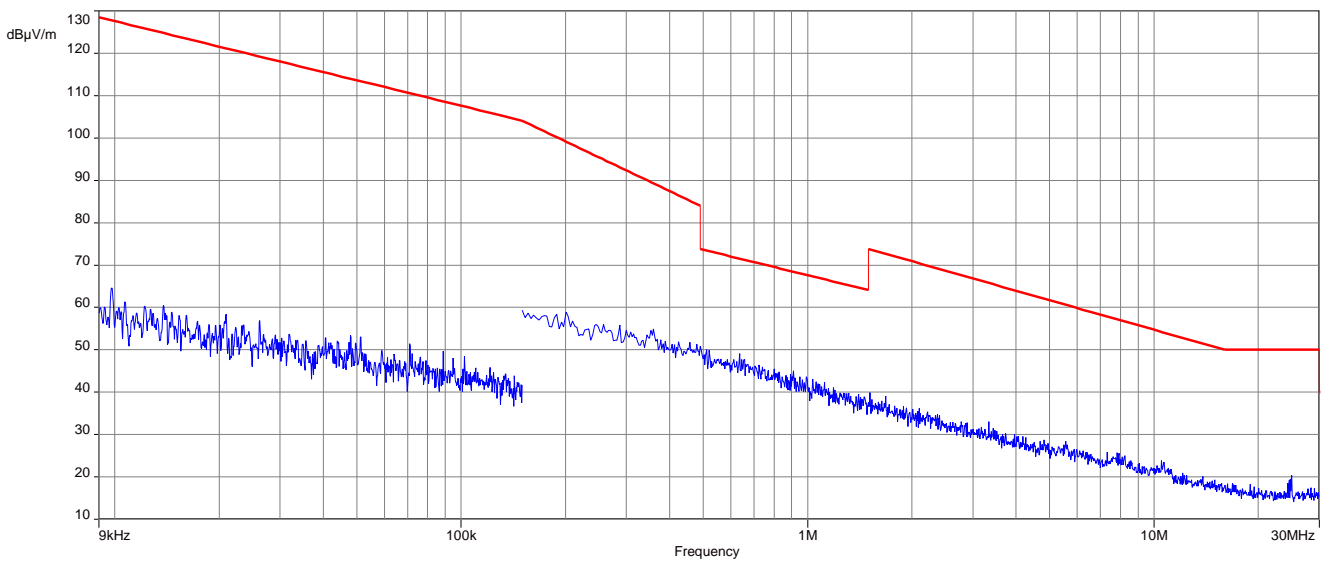

Plots: 40 MHz channel bandwidth

Plot 1: 9 kHz to 30 MHz, U-NII-1; lowest channel

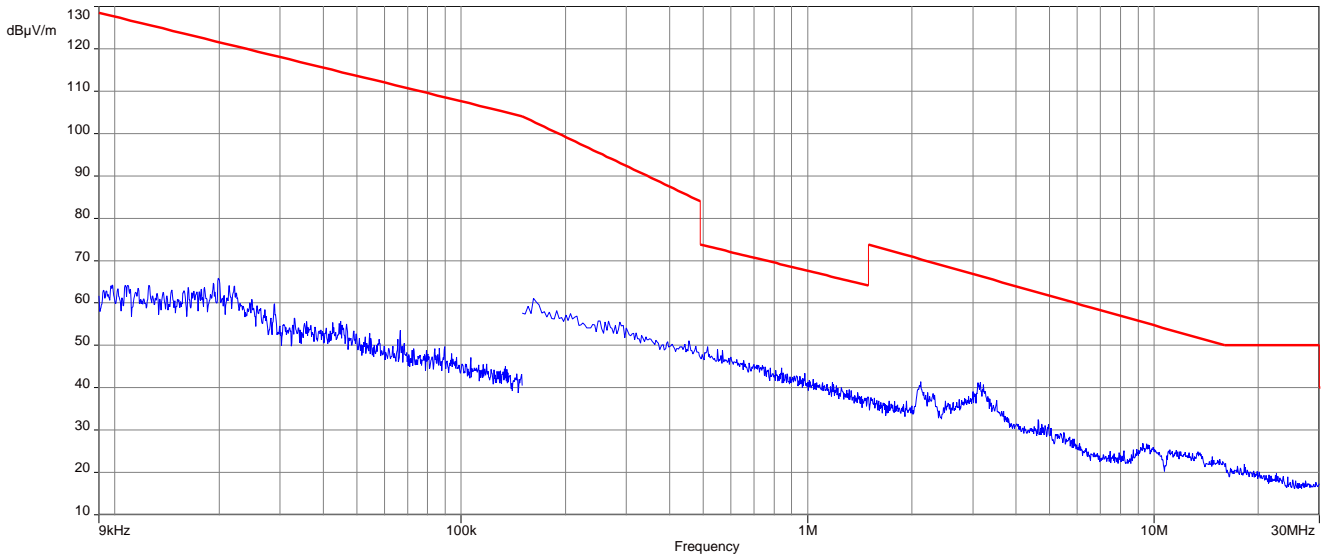

Plot 2: 9 kHz to 30 MHz, U-NII-1; highest channel

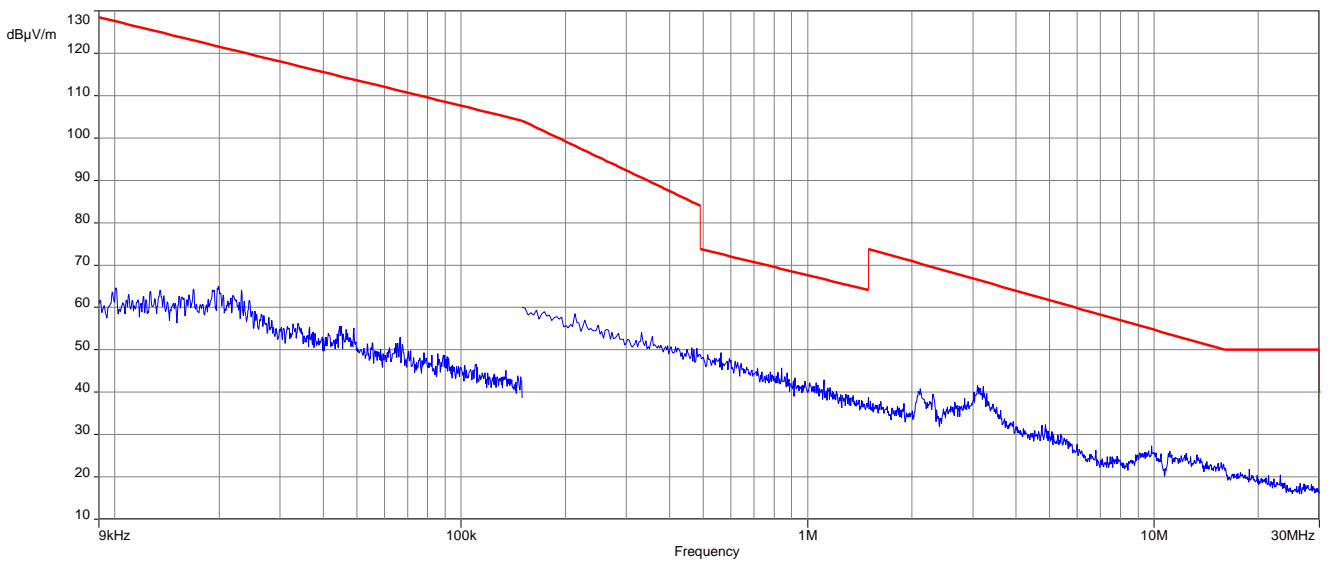

Plot 3: 9 kHz to 30 MHz, U-NII-2A; lowest channel

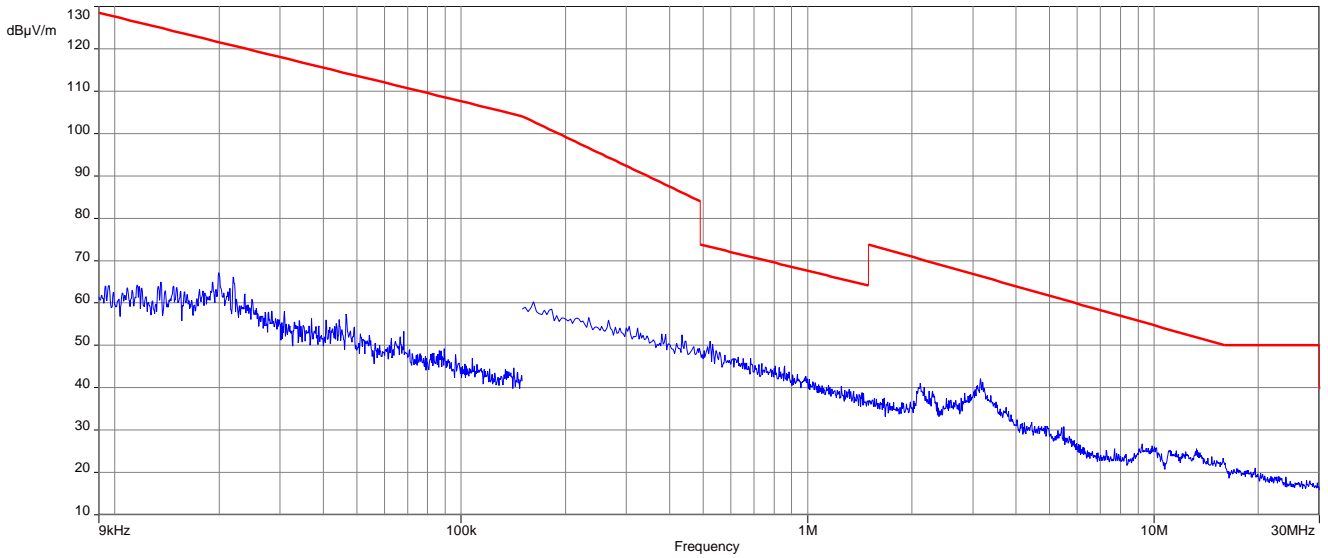

Plot 4: 9 kHz to 30 MHz, U-NII-2A; highest channel

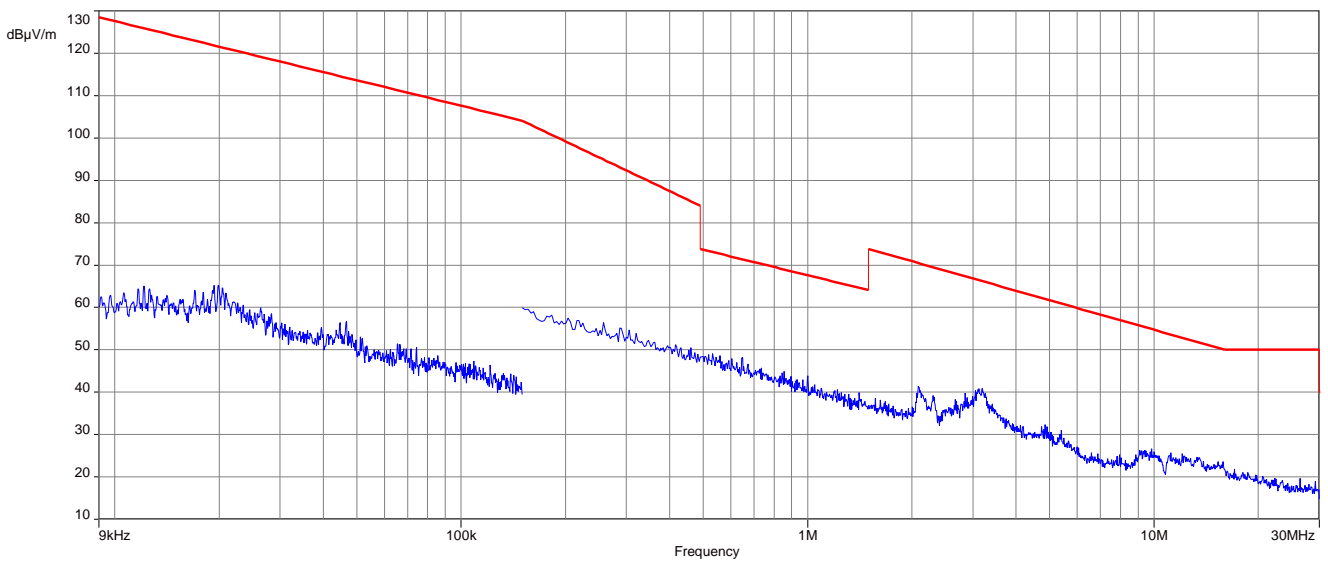

Plot 5: 9 kHz to 30 MHz, U-NII-2C; lowest channel

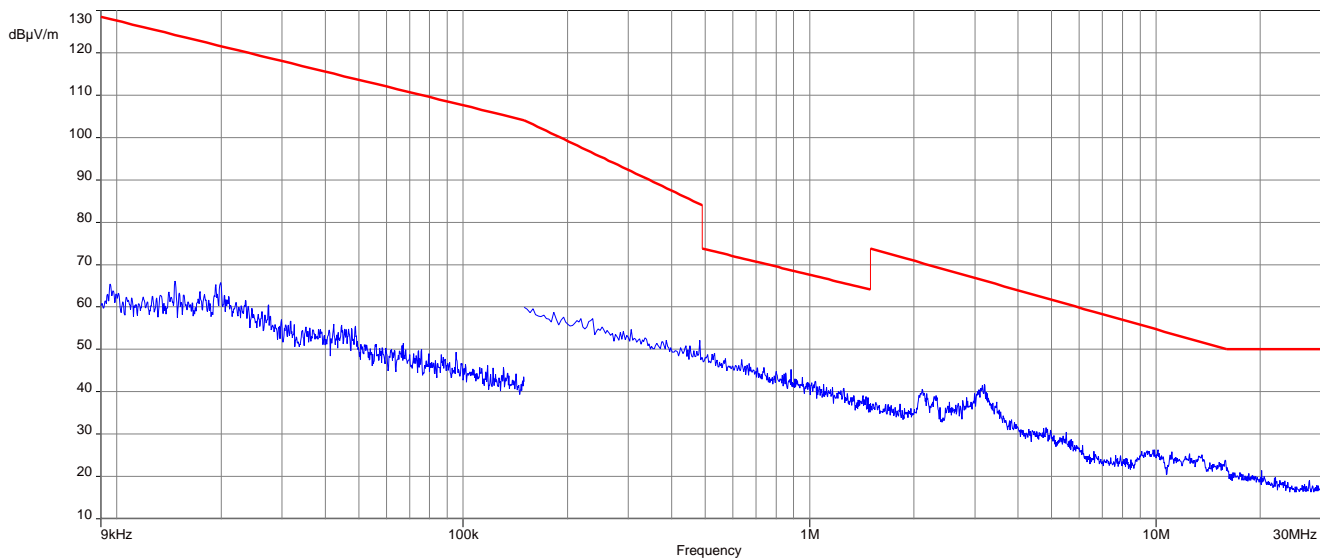

Plot 6: 9 kHz to 30 MHz, U-NII-2C; middle channel

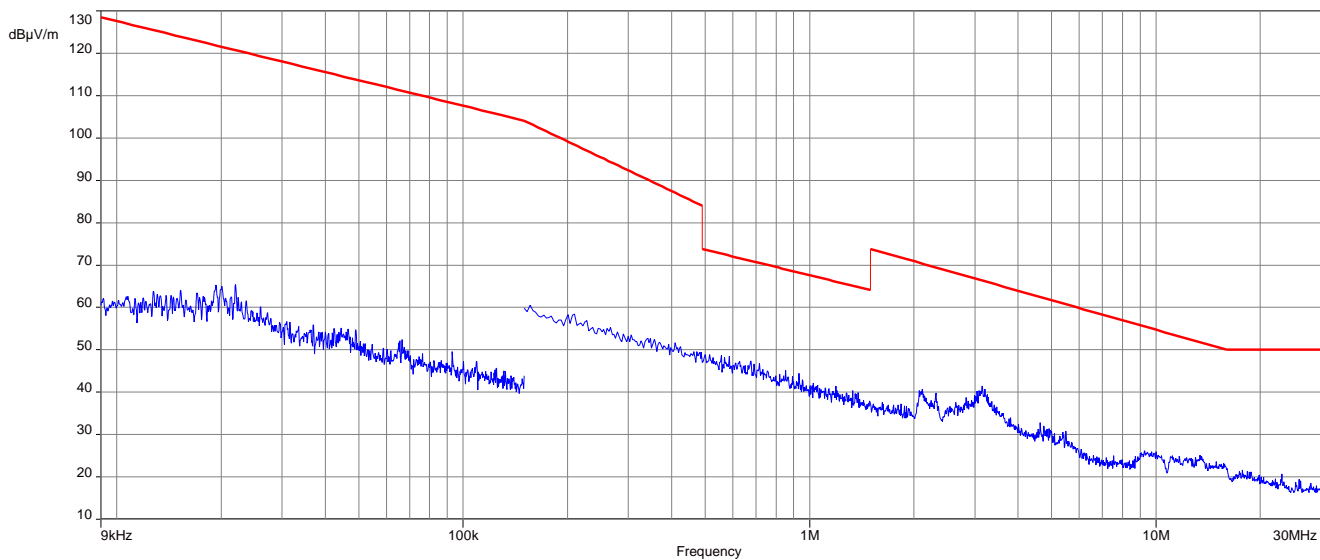

Plot 7: 9 kHz to 30 MHz, U-NII-2C; highest channel

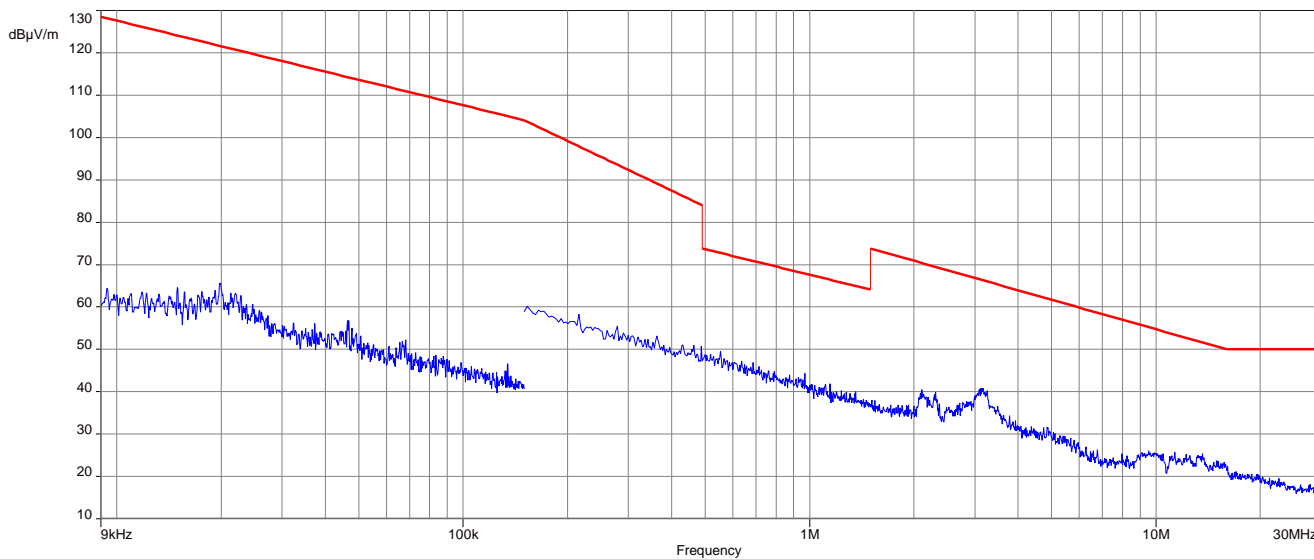

Plot 8: 9 kHz to 30 MHz, U-NII-3; lowest channel

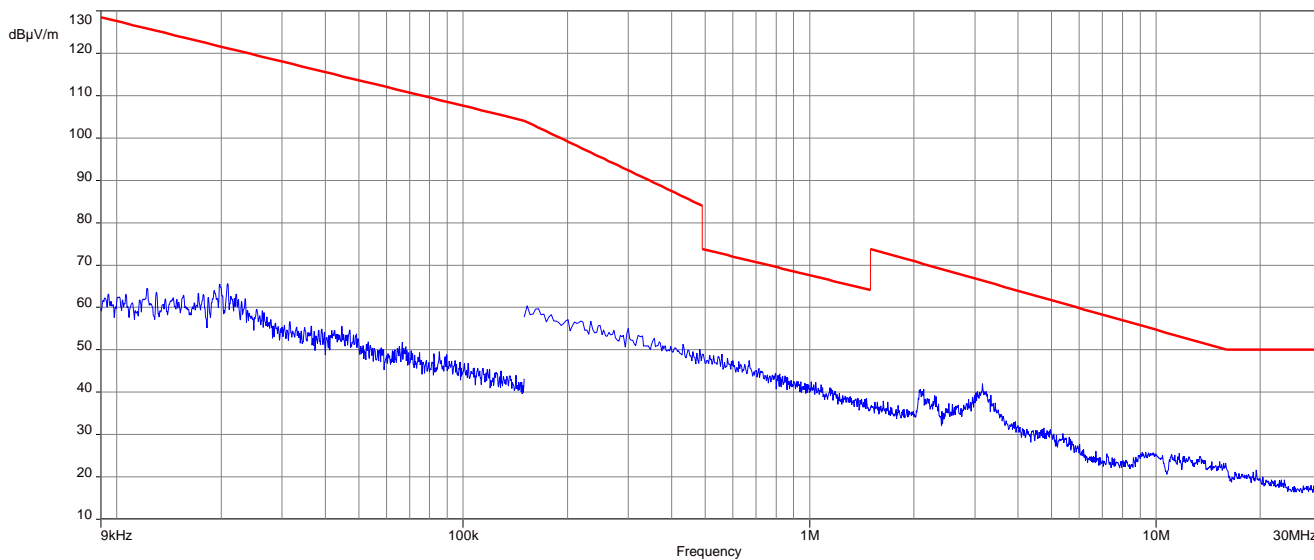

Plot 9: 9 kHz to 30 MHz, U-NII-3; highest channel

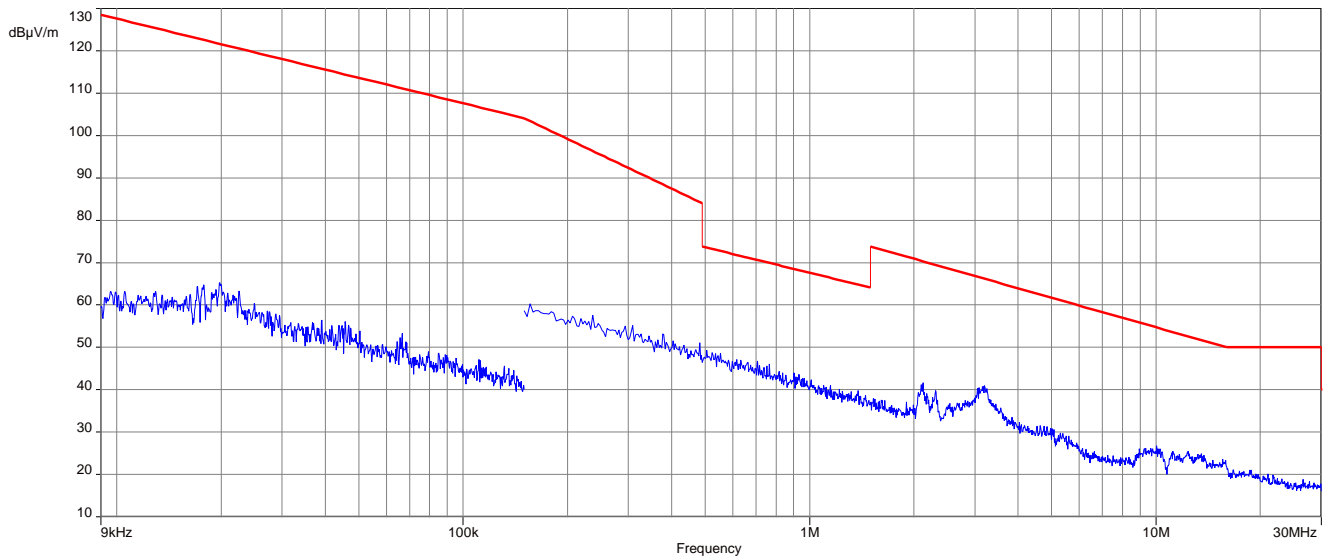

11.11 Spurious emissions radiated 30 MHz to 1 GHz

Description:

Measurement of the radiated spurious emissions and cabinet radiations below 1 GHz.

Measurement:

Measurement parameter	
Detector:	Quasi Peak
Sweep time:	Auto
Resolution bandwidth:	120 kHz
Video bandwidth:	500 kHz
Span:	30 MHz to 1 GHz
Test setup:	See sub clause 6.1 – A See sub clause 6.2 – B See sub clause 6.3 – A
Measurement uncertainty:	See chapter 8

Limits:

TX Spurious Emissions Radiated		
§15.209		
Frequency (MHz)	Field Strength (dBµV/m)	Measurement distance
30 - 88	30.0	10
88 – 216	33.5	10
216 – 960	36.0	10
Above 960	54.0	3
§15.407		
Outside the restricted bands!	-27 dBm / MHz	

Plots: 20 MHz channel bandwidth

Plot 1: 30 MHz to 1 GHz; vertical & horizontal polarization; U-NII-1; lowest channel

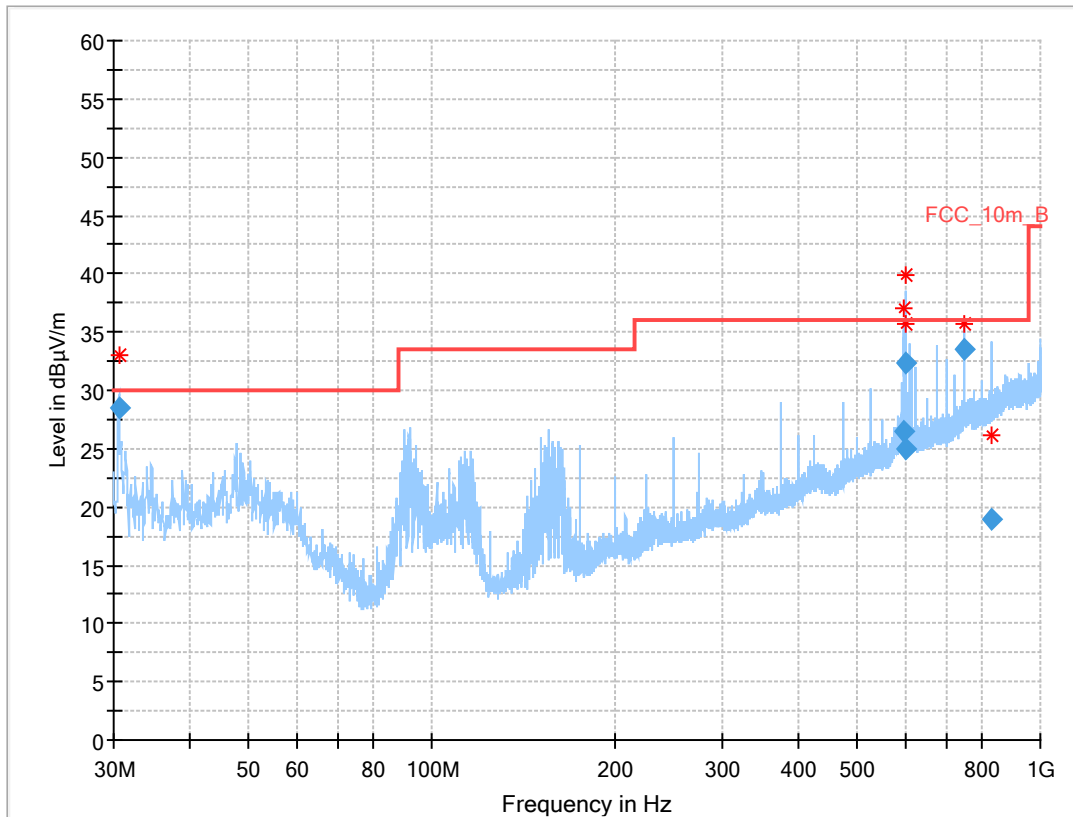

Results:

Frequency (MHz)	QuasiPeak (dBµV/m)	Limit (dBµV/m)	Margin (dB)	Meas. Time (ms)	Bandwidth (kHz)	Height (cm)	Pol	Azimuth (deg)	Corr. (dB)
30.611	28.45	30.0	1.6	1000	120	101.0	V	254	12
598.324	26.41	36.0	9.6	1000	120	160.0	H	268	20
600.000	32.40	36.0	3.6	1000	120	160.0	H	80	20
601.630	25.04	36.0	11.0	1000	120	160.0	H	268	20
749.995	33.57	36.0	2.4	1000	120	132.0	H	304	22
832.504	18.86	36.0	17.1	1000	120	160.0	H	119	23

Plot 2: 30 MHz to 1 GHz; vertical & horizontal polarization; U-NII-1; middle channel

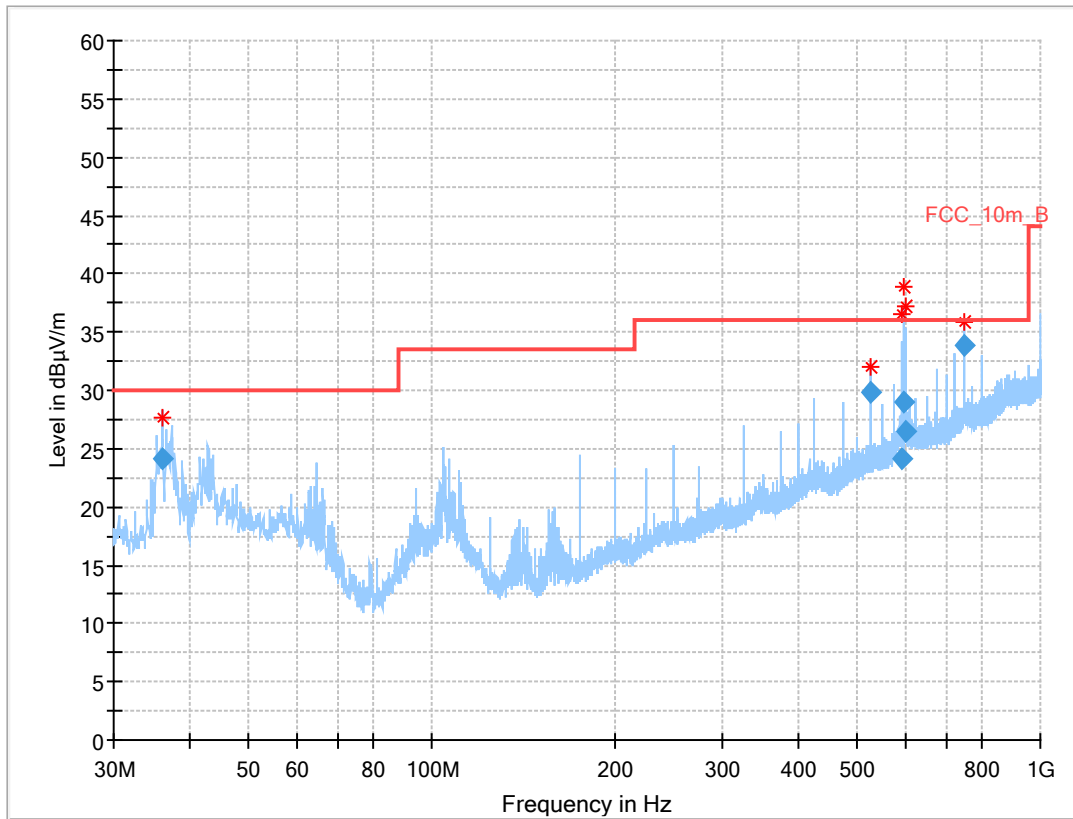

Results:

Frequency (MHz)	QuasiPeak (dBµV/m)	Limit (dBµV/m)	Margin (dB)	Meas. Time (ms)	Bandwidth (kHz)	Height (cm)	Pol	Azimuth (deg)	Corr. (dB)
36.132	24.07	30.0	5.9	1000	120	116.0	V	280	13
525.007	29.84	36.0	6.2	1000	120	160.0	H	273	19
591.038	24.06	36.0	11.9	1000	120	160.0	H	294	20
598.343	29.07	36.0	6.9	1000	120	160.0	H	267	20
601.674	26.51	36.0	9.5	1000	120	160.0	H	355	20
750.005	33.91	36.0	2.1	1000	120	130.0	H	185	22

Plot 3: 30 MHz to 1 GHz; vertical & horizontal polarization; U-NII-1; highest channel

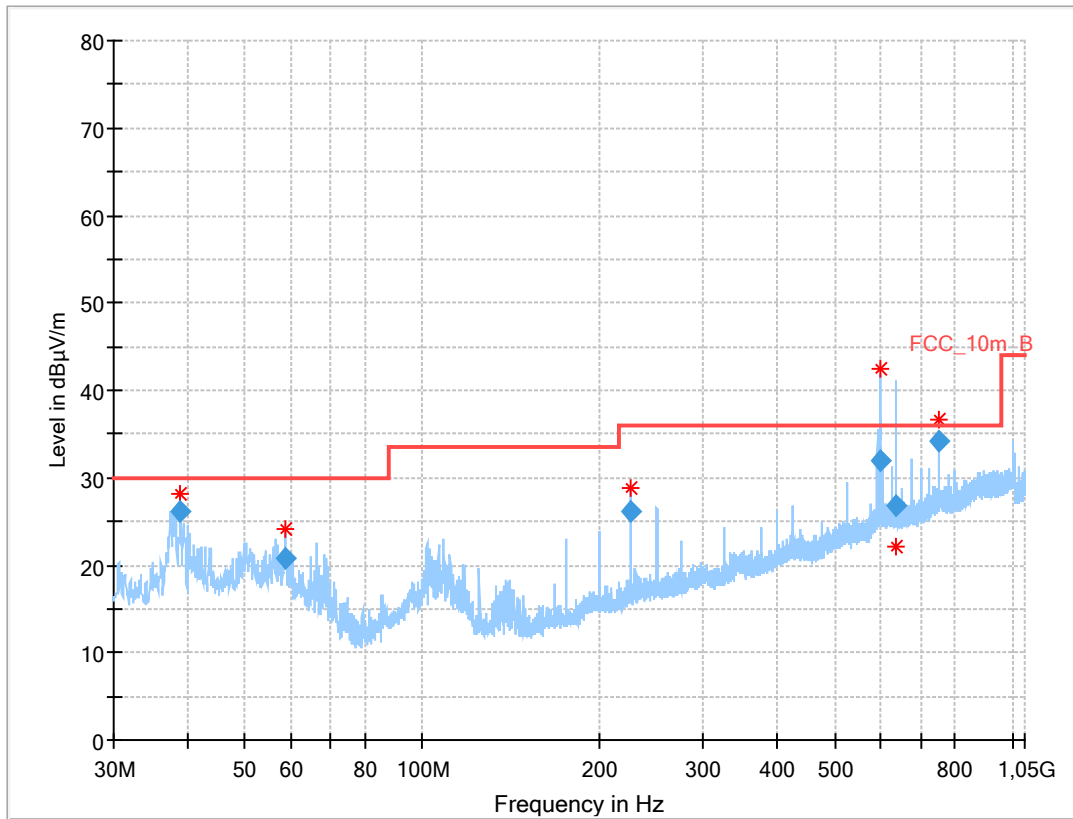

Results:

Frequency (MHz)	QuasiPeak (dBµV/m)	Limit (dBµV/m)	Margin (dB)	Meas. Time (ms)	Bandwidth (kHz)	Height (cm)	Pol	Azimuth (deg)	Corr. (dB)
38.941	26.25	30.0	3.8	1000	120	98.0	V	202	13
58.721	20.80	30.0	9.2	1000	120	170.0	V	178	14
224.998	26.22	36.0	9.8	1000	120	127.0	V	-22	12
598.330	31.90	36.0	4.1	1000	120	127.0	H	277	20
635.742	26.92	36.0	9.1	1000	120	170.0	V	-22	20
749.996	34.23	36.0	1.8	1000	120	137.0	H	202	22

Plot 4: 30 MHz to 1 GHz; vertical & horizontal polarization; U-NII-2A; lowest channel

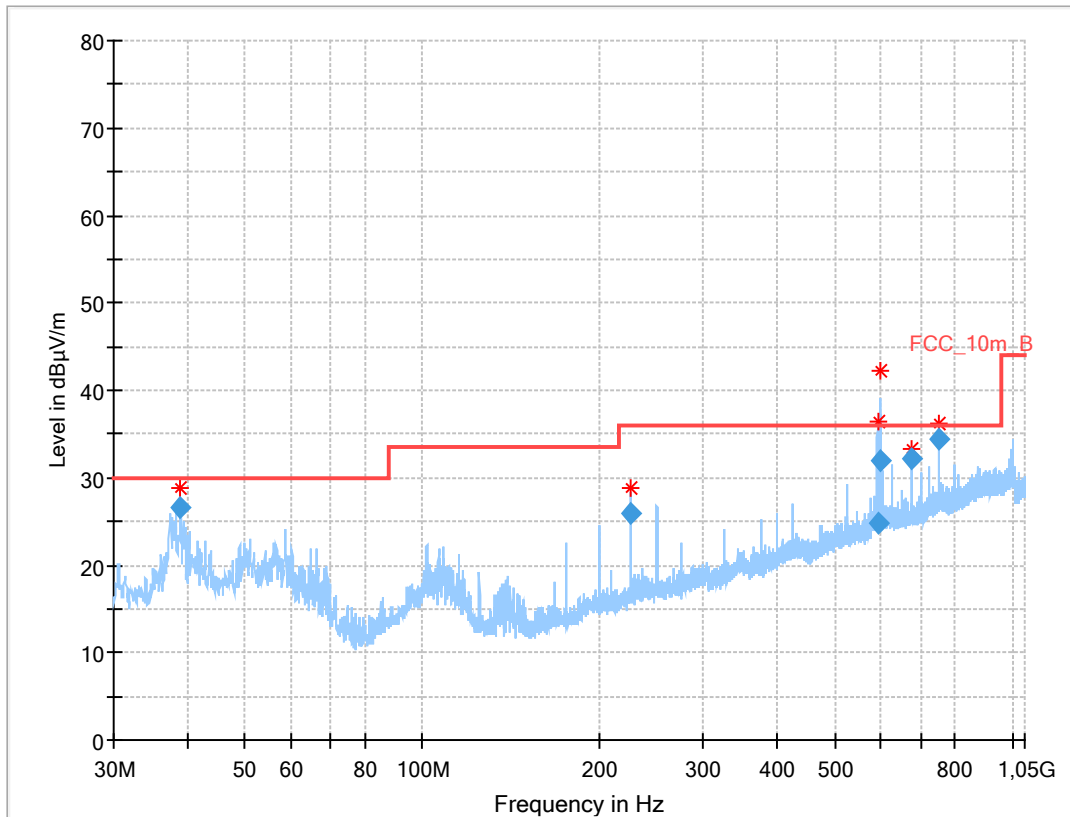

Results:

Frequency (MHz)	QuasiPeak (dBµV/m)	Limit (dBµV/m)	Margin (dB)	Meas. Time (ms)	Bandwidth (kHz)	Height (cm)	Pol	Azimuth (deg)	Corr. (dB)
38.948	26.63	30.0	3.4	1000	120	114.0	V	157	13
224.996	25.99	36.0	10.0	1000	120	170.0	V	-21	12
590.979	24.73	36.0	11.3	1000	120	170.0	H	274	20
598.340	31.96	36.0	4.0	1000	120	143.0	H	276	20
674.995	32.11	36.0	3.9	1000	120	170.0	H	247	21
749.998	34.32	36.0	1.7	1000	120	155.0	H	202	22

Plot 5: 30 MHz to 1 GHz; vertical & horizontal polarization; U-NII-2A; middle channel

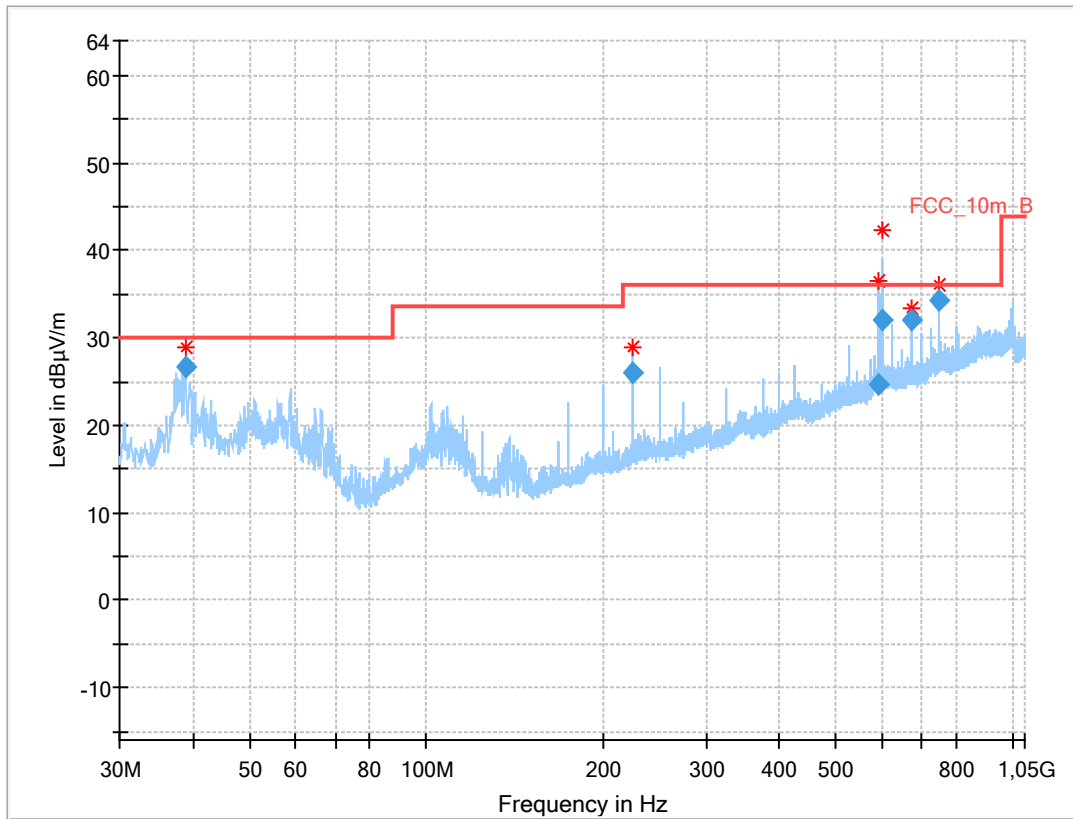

Results:

Frequency (MHz)	QuasiPeak (dBµV/m)	Limit (dBµV/m)	Margin (dB)	Meas. Time (ms)	Bandwidth (kHz)	Height (cm)	Pol	Azimuth (deg)	Corr. (dB)
38.948	26.63	30.0	3.4	1000	120	114.0	V	157	13
224.996	25.99	36.0	10.0	1000	120	170.0	V	-21	12
590.979	24.73	36.0	11.3	1000	120	170.0	H	274	20
598.340	31.96	36.0	4.0	1000	120	143.0	H	276	20
674.995	32.11	36.0	3.9	1000	120	170.0	H	247	21
749.998	34.32	36.0	1.7	1000	120	155.0	H	202	22

Plot 6: 30 MHz to 1 GHz; vertical & horizontal polarization; U-NII-2A; highest channel

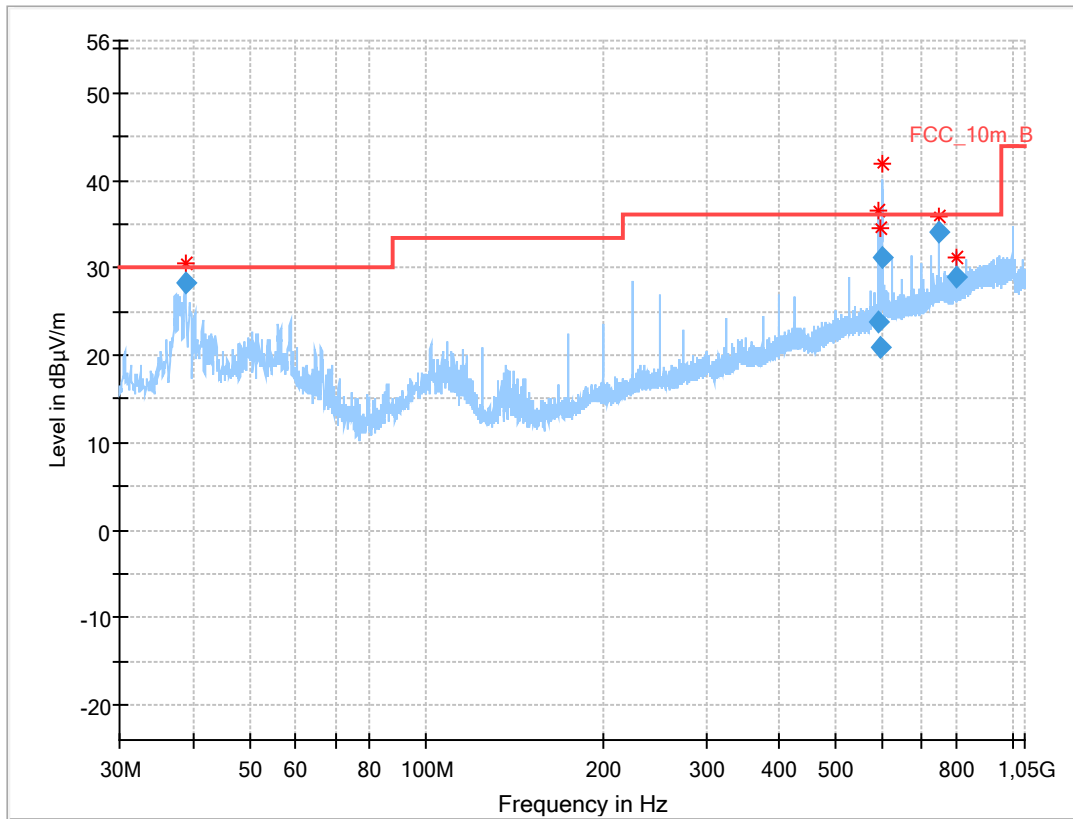

Results:

Frequency (MHz)	QuasiPeak (dBµV/m)	Limit (dBµV/m)	Margin (dB)	Meas. Time (ms)	Bandwidth (kHz)	Height (cm)	Pol	Azimuth (deg)	Corr. (dB)
38.949	28.35	30.0	1.7	1000	120	101.0	V	202	13
591.030	23.91	36.0	12.1	1000	120	162.0	H	278	20
594.648	21.02	36.0	15.0	1000	120	170.0	H	279	20
598.313	31.12	36.0	4.9	1000	120	151.0	H	279	20
749.991	34.07	36.0	1.9	1000	120	129.0	H	202	22
799.996	29.00	36.0	7.0	1000	120	148.0	H	202	22

Plot 7: 30 MHz to 1 GHz; vertical & horizontal polarization; U-NII-2C; lowest channel

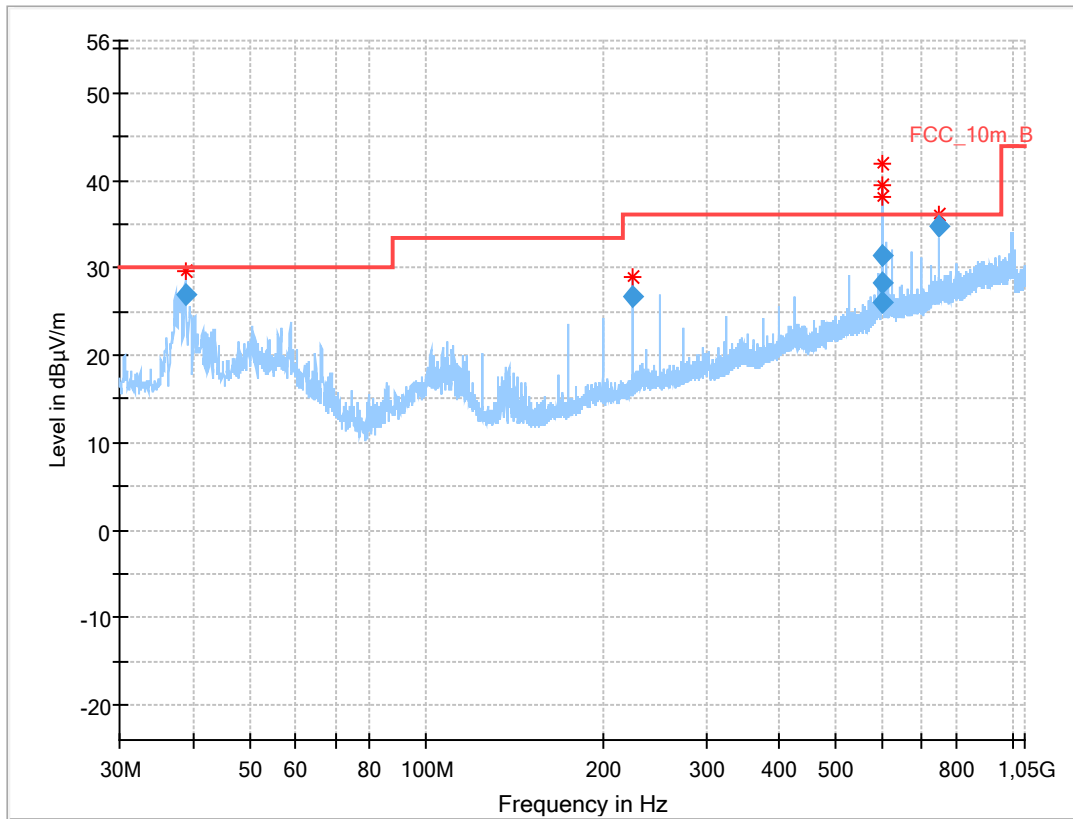

Results:

Frequency (MHz)	QuasiPeak (dBµV/m)	Limit (dBµV/m)	Margin (dB)	Meas. Time (ms)	Bandwidth (kHz)	Height (cm)	Pol	Azimuth (deg)	Corr. (dB)
38.943	26.97	30.0	3.0	1000	120	139.0	V	286	13
224.996	26.71	36.0	9.3	1000	120	133.0	V	13	12
598.072	26.05	36.0	10.0	1000	120	170.0	H	112	20
598.323	28.32	36.0	7.7	1000	120	170.0	H	112	20
601.682	31.39	36.0	4.6	1000	120	144.0	H	265	20
749.987	34.74	36.0	1.3	1000	120	132.0	H	202	22

Plot 8: 30 MHz to 1 GHz; vertical & horizontal polarization; U-NII-2C; middle channel

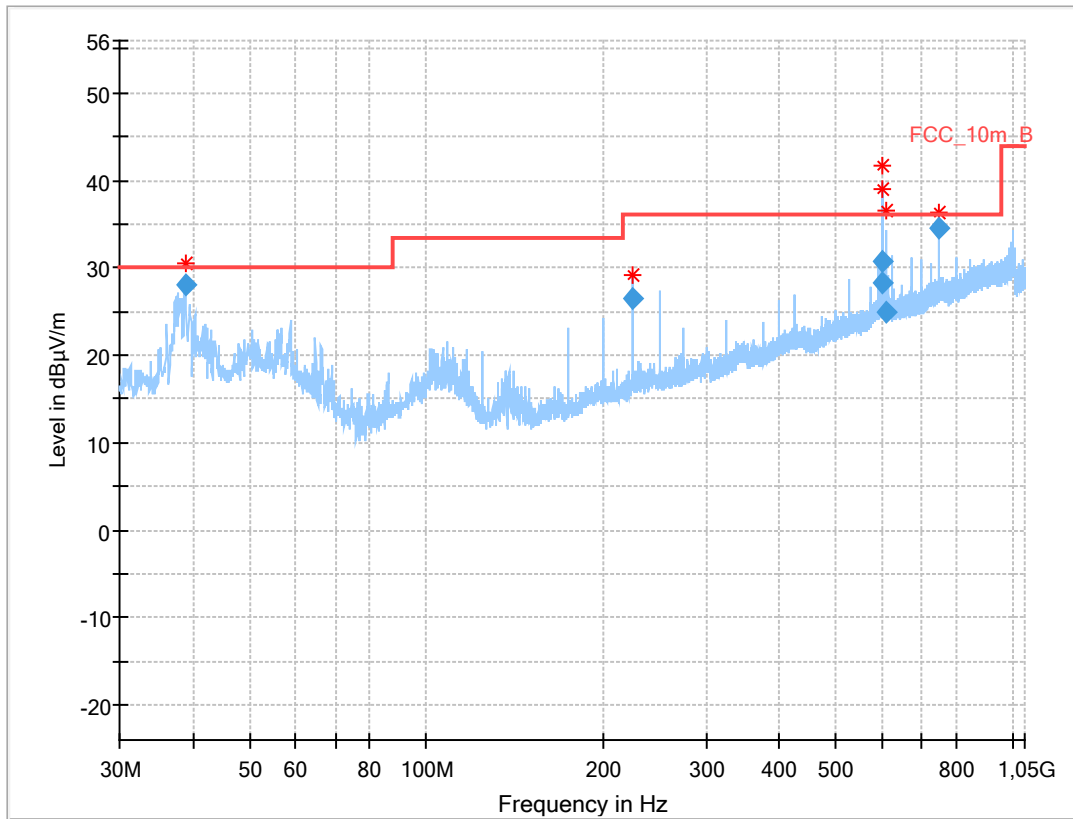

Results:

Frequency (MHz)	QuasiPeak (dBµV/m)	Limit (dBµV/m)	Margin (dB)	Meas. Time (ms)	Bandwidth (kHz)	Height (cm)	Pol	Azimuth (deg)	Corr. (dB)
38.949	28.13	30.0	1.9	1000	120	118.0	V	202	13
224.999	26.52	36.0	9.5	1000	120	170.0	V	22	12
598.334	28.39	36.0	7.6	1000	120	170.0	H	112	20
601.694	30.73	36.0	5.3	1000	120	153.0	H	276	20
608.904	25.05	36.0	11.0	1000	120	170.0	H	273	21
749.995	34.46	36.0	1.5	1000	120	132.0	H	202	22

Plot 9: 30 MHz to 1 GHz; vertical & horizontal polarization; U-NII-2C; highest channel

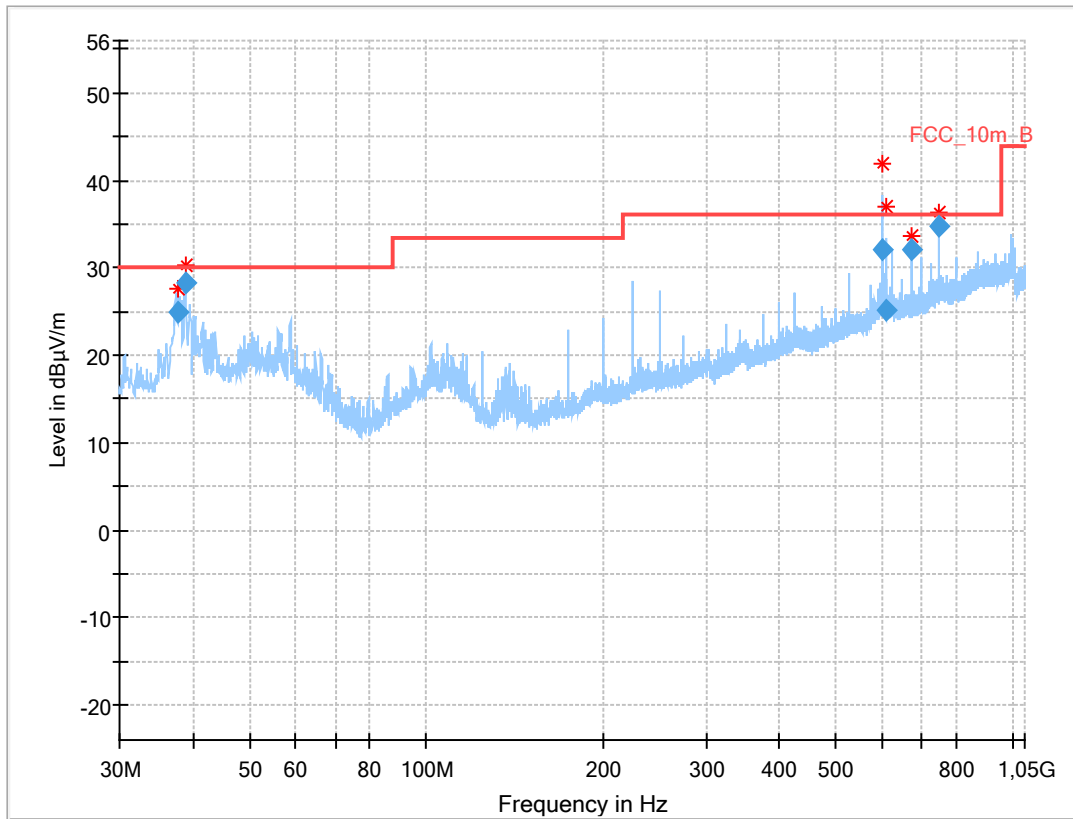

Results:

Frequency (MHz)	QuasiPeak (dBµV/m)	Limit (dBµV/m)	Margin (dB)	Meas. Time (ms)	Bandwidth (kHz)	Height (cm)	Pol	Azimuth (deg)	Corr. (dB)
37.801	24.89	30.0	5.1	1000	120	102.0	V	292	13
38.957	28.28	30.0	1.7	1000	120	107.0	V	202	13
601.668	31.99	36.0	4.0	1000	120	151.0	H	279	20
608.984	25.19	36.0	10.8	1000	120	170.0	H	280	21
675.006	32.17	36.0	3.8	1000	120	166.0	H	247	21
750.002	34.72	36.0	1.3	1000	120	130.0	H	202	22

Plot 10: 30 MHz to 1 GHz; vertical & horizontal polarization; U-NII-3; lowest channel

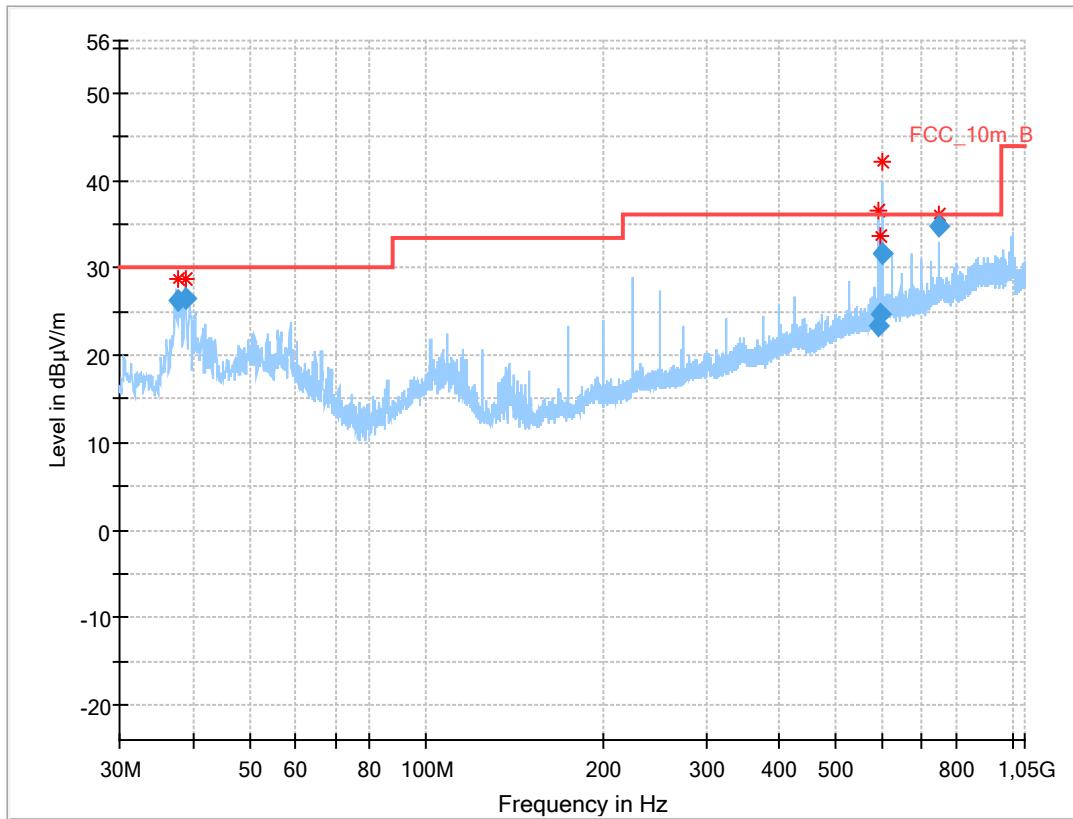

Results:

Frequency (MHz)	QuasiPeak (dBµV/m)	Limit (dBµV/m)	Margin (dB)	Meas. Time (ms)	Bandwidth (kHz)	Height (cm)	Pol	Azimuth (deg)	Corr. (dB)
37.778	26.33	30.0	3.7	1000	120	131.0	V	202	13
38.949	26.58	30.0	3.4	1000	120	107.0	V	264	13
591.057	23.41	36.0	12.6	1000	120	170.0	H	279	20
594.718	24.63	36.0	11.4	1000	120	134.0	H	292	20
598.314	31.55	36.0	4.5	1000	120	139.0	H	275	20
749.995	34.86	36.0	1.1	1000	120	132.0	H	202	22

Plot 11: 30 MHz to 1 GHz; vertical & horizontal polarization; U-NII-3; middle channel

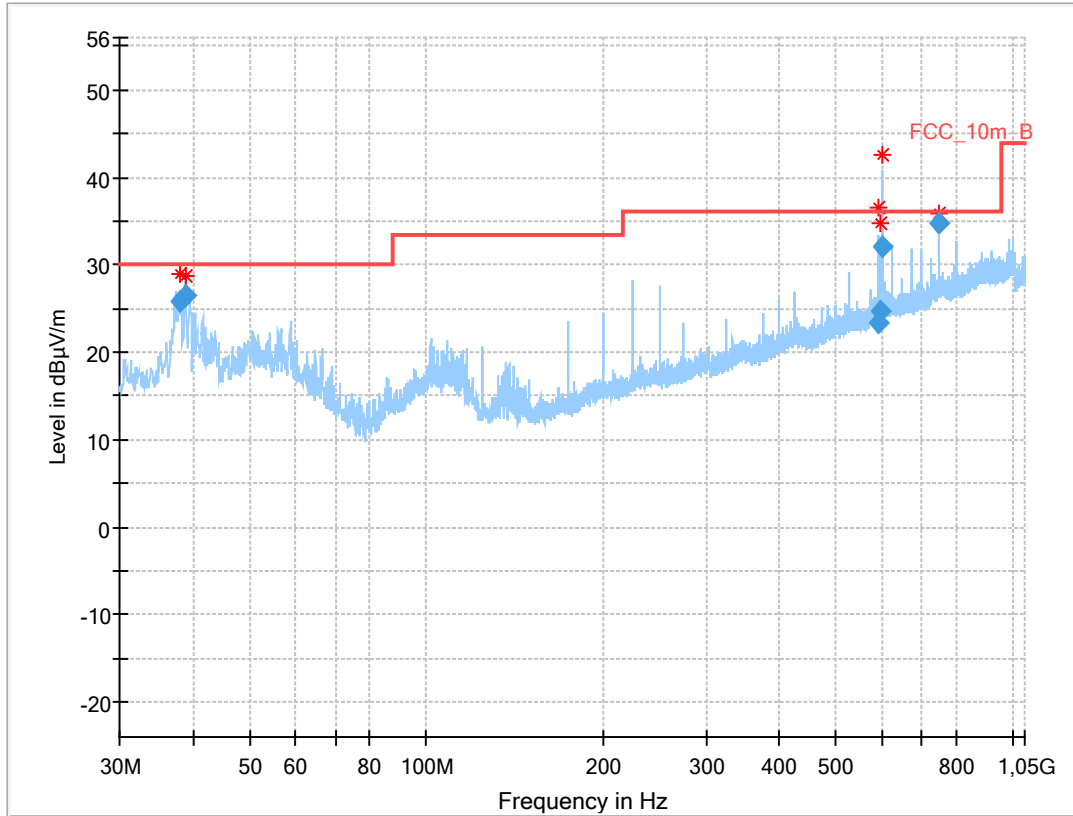

Results:

Frequency (MHz)	QuasiPeak (dBµV/m)	Limit (dBµV/m)	Margin (dB)	Meas. Time (ms)	Bandwidth (kHz)	Height (cm)	Pol	Azimuth (deg)	Corr. (dB)
38.088	25.91	30.0	4.1	1000	120	122.0	V	202	13
38.957	26.55	30.0	3.5	1000	120	98.0	V	262	13
591.065	23.46	36.0	12.5	1000	120	170.0	H	249	20
594.678	24.68	36.0	11.3	1000	120	159.0	H	268	20
598.325	32.06	36.0	3.9	1000	120	138.0	H	276	20
749.991	34.67	36.0	1.3	1000	120	137.0	H	202	22

Plot 12: 30 MHz to 1 GHz; vertical & horizontal polarization; U-NII-3; highest channel

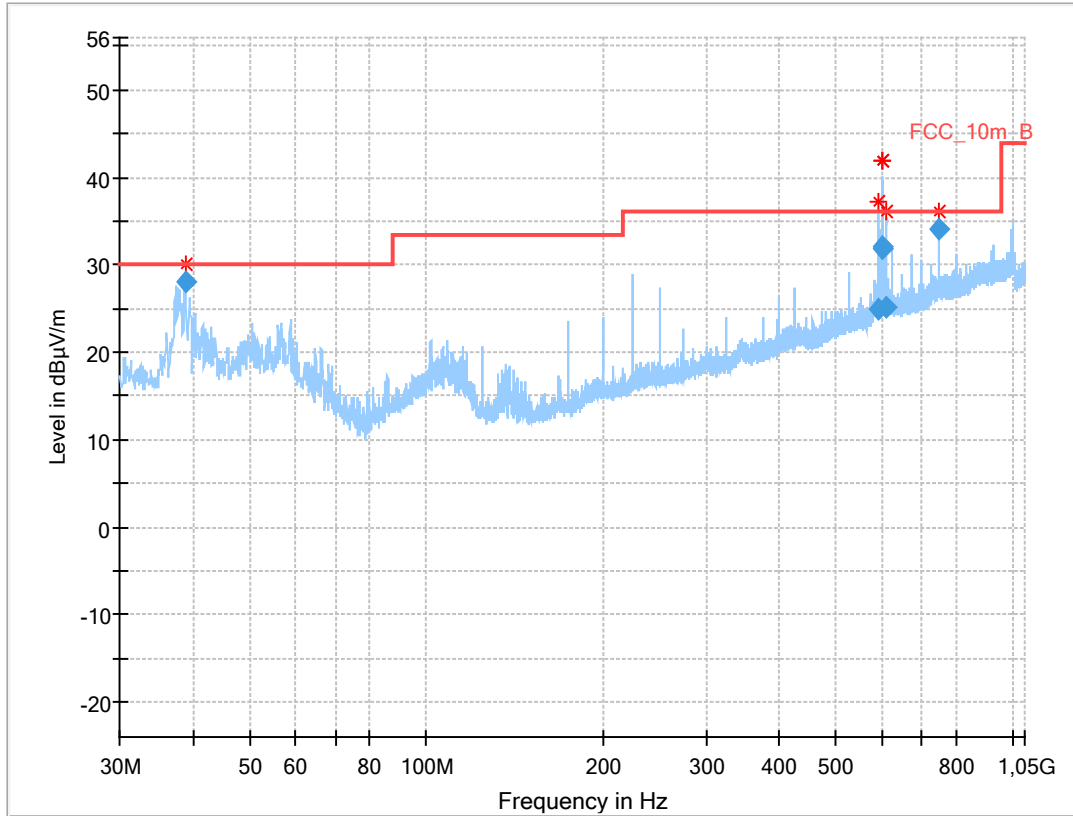

Results:

Frequency (MHz)	QuasiPeak (dBµV/m)	Limit (dBµV/m)	Margin (dB)	Meas. Time (ms)	Bandwidth (kHz)	Height (cm)	Pol	Azimuth (deg)	Corr. (dB)
38.936	28.05	30.0	2.0	1000	120	101.0	V	202	13
591.008	24.98	36.0	11.0	1000	120	138.0	H	272	20
598.343	32.03	36.0	4.0	1000	120	134.0	H	275	20
601.657	31.88	36.0	4.1	1000	120	155.0	H	279	20
608.963	25.08	36.0	10.9	1000	120	170.0	H	266	21
749.992	34.09	36.0	1.9	1000	120	132.0	H	202	22

Plots: 40 MHz channel bandwidth

Plot 1: 30 MHz to 1 GHz; vertical & horizontal polarization; U-NII-1; lowest channel

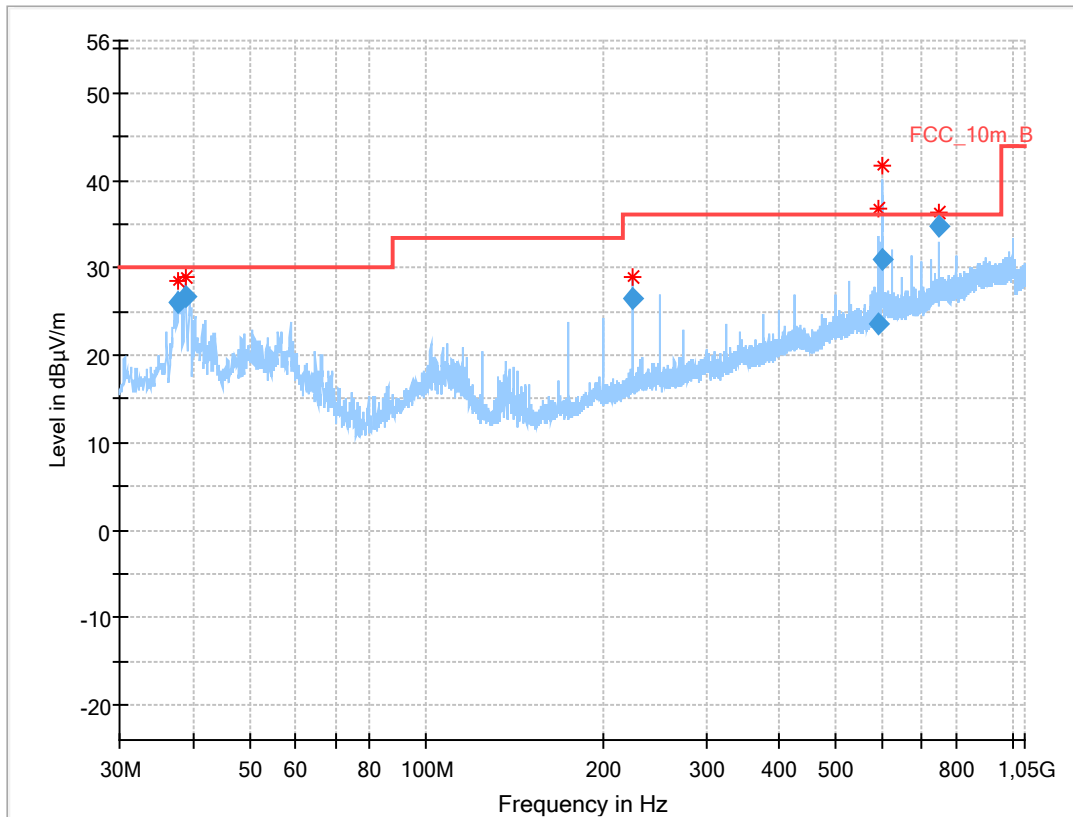

Results:

Frequency (MHz)	QuasiPeak (dBµV/m)	Limit (dBµV/m)	Margin (dB)	Meas. Time (ms)	Bandwidth (kHz)	Height (cm)	Pol	Azimuth (deg)	Corr. (dB)
37.799	26.01	30.0	4.0	1000	120	151.0	V	188	13
38.956	26.78	30.0	3.2	1000	120	98.0	V	263	13
224.989	26.47	36.0	9.5	1000	120	151.0	V	22	12
591.029	23.69	36.0	12.3	1000	120	170.0	H	273	20
598.308	31.04	36.0	5.0	1000	120	139.0	H	266	20
749.985	34.75	36.0	1.3	1000	120	131.0	H	202	22

Plot 2: 30 MHz to 1 GHz; vertical & horizontal polarization; U-NII-1; highest channel

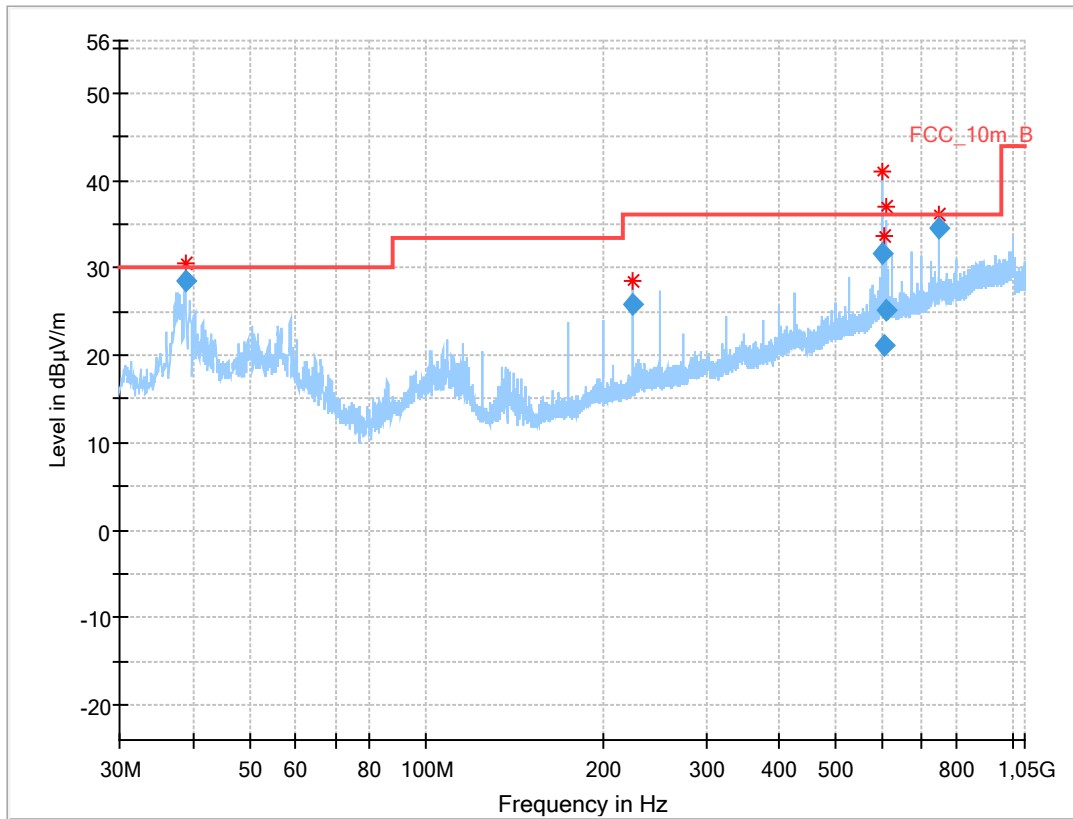

Results:

Frequency (MHz)	QuasiPeak (dBµV/m)	Limit (dBµV/m)	Margin (dB)	Meas. Time (ms)	Bandwidth (kHz)	Height (cm)	Pol	Azimuth (deg)	Corr. (dB)
38.948	28.50	30.0	1.5	1000	120	101.0	V	202	13
224.982	25.85	36.0	10.2	1000	120	110.0	V	-22	12
601.651	31.55	36.0	4.5	1000	120	136.0	H	248	20
605.308	21.20	36.0	14.8	1000	120	134.0	H	259	20
608.947	25.11	36.0	10.9	1000	120	170.0	H	260	21
749.991	34.65	36.0	1.4	1000	120	124.0	H	202	22

Plot 3: 30 MHz to 1 GHz; vertical & horizontal polarization; U-NII-2A; lowest channel

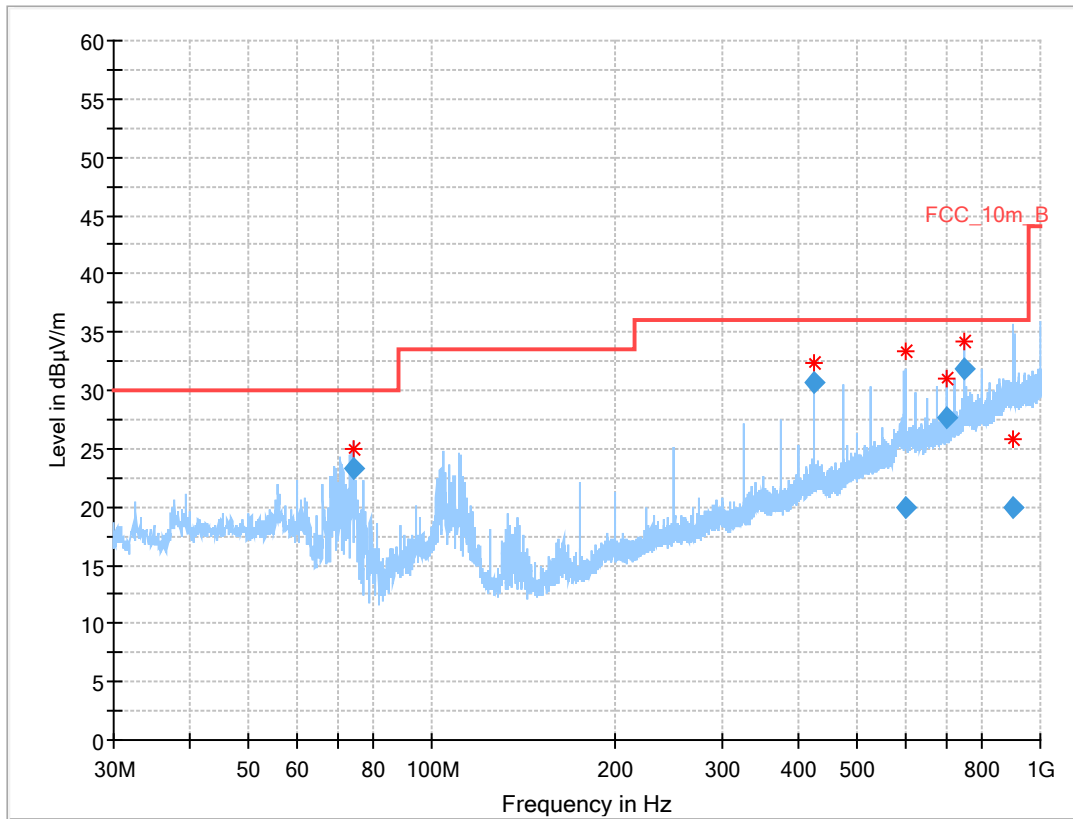

Results:

Frequency (MHz)	QuasiPeak (dBµV/m)	Limit (dBµV/m)	Margin (dB)	Meas. Time (ms)	Bandwidth (kHz)	Height (cm)	Pol	Azimuth (deg)	Corr. (dB)
74.550	23.27	30.0	6.7	1000	120	160.0	V	355	8
424.992	30.71	36.0	5.3	1000	120	160.0	H	85	17
601.763	19.93	36.0	16.1	1000	120	160.0	H	66	20
699.997	27.62	36.0	8.4	1000	120	160.0	H	224	21
749.991	31.76	36.0	4.2	1000	120	129.0	H	241	22
904.510	20.02	36.0	16.0	1000	120	160.0	H	294	24

Plot 4: 30 MHz to 1 GHz; vertical & horizontal polarization; U-NII-2A; highest channel

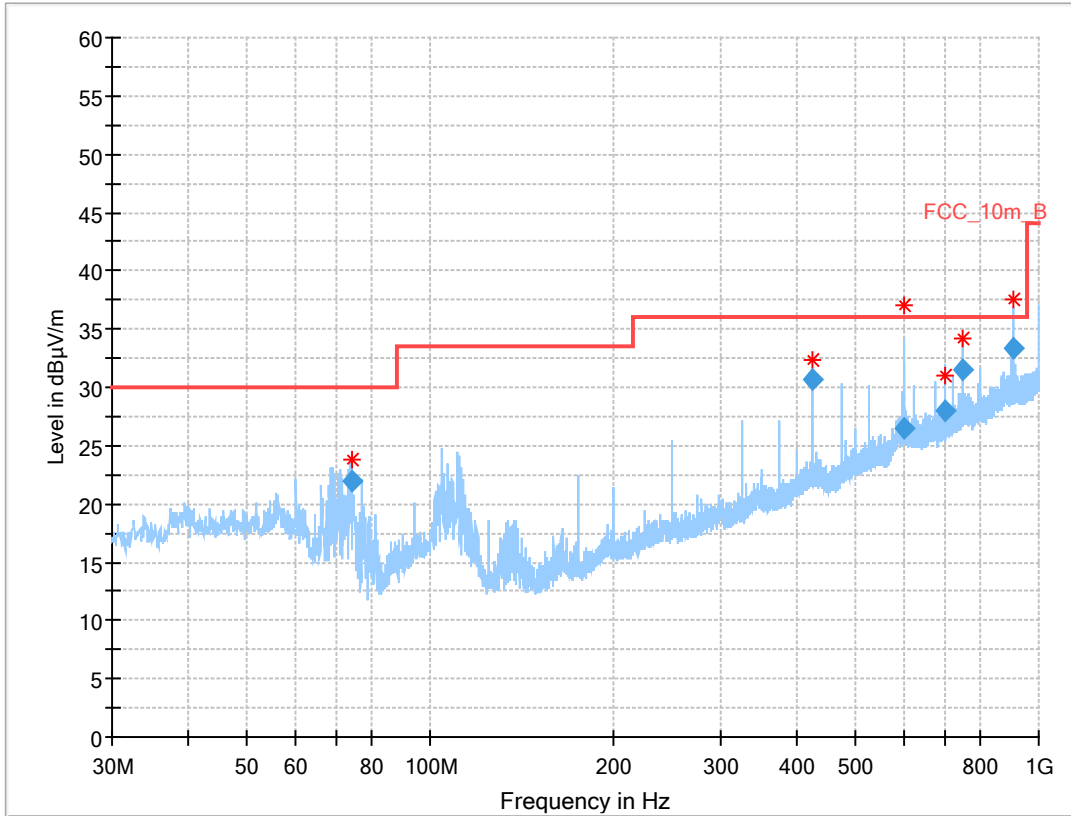

t

Results:

Frequency (MHz)	QuasiPeak (dBµV/m)	Limit (dBµV/m)	Margin (dB)	Meas. Time (ms)	Bandwidth (kHz)	Height (cm)	Pol	Azimuth (deg)	Corr. (dB)
74.557	21.89	30.0	8.1	1000	120	160.0	V	355	8
425.006	30.62	36.0	5.4	1000	120	160.0	H	98	17
599.965	26.48	36.0	9.5	1000	120	160.0	H	43	20
700.001	28.07	36.0	7.9	1000	120	149.0	H	213	21
750.000	31.46	36.0	4.5	1000	120	153.0	H	235	22
905.472	33.29	36.0	2.7	1000	120	131.0	H	312	24

Plot 5: 30 MHz to 1 GHz; vertical & horizontal polarization; U-NII-2C; lowest channel

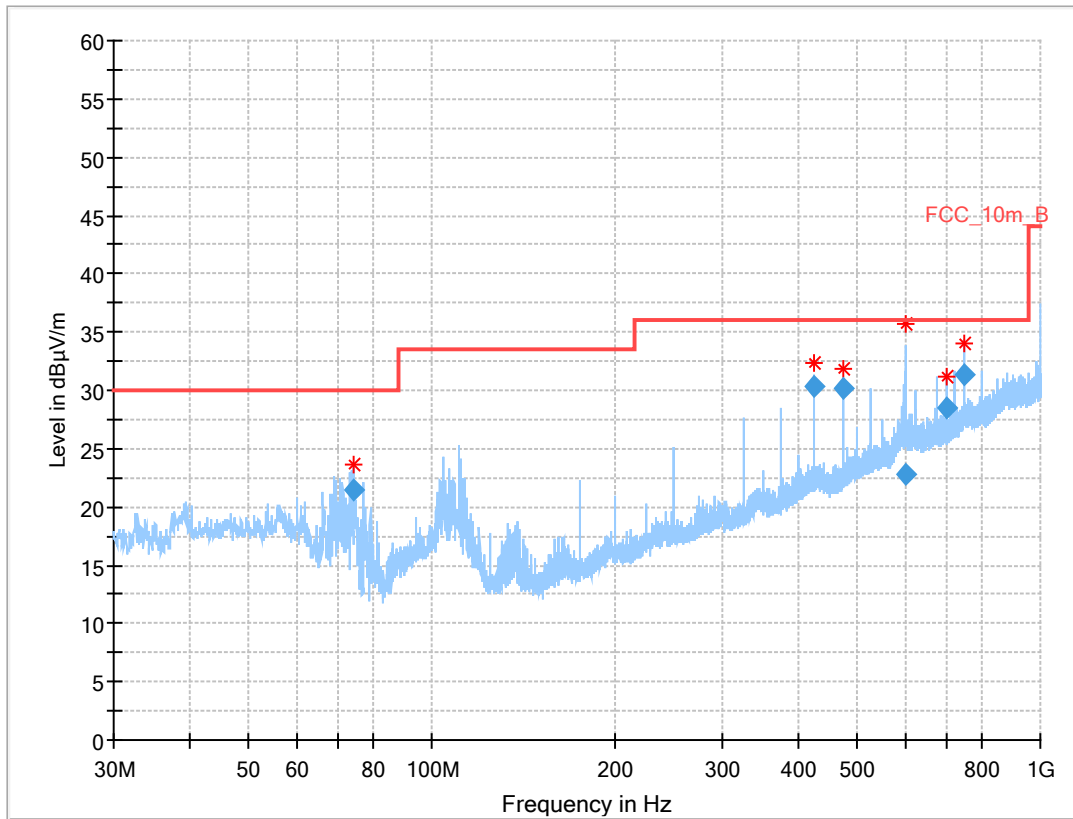

Results:

Frequency (MHz)	QuasiPeak (dBµV/m)	Limit (dBµV/m)	Margin (dB)	Meas. Time (ms)	Bandwidth (kHz)	Height (cm)	Pol	Azimuth (deg)	Corr. (dB)
74.574	21.46	30.0	8.5	1000	120	155.0	V	347	8
425.003	30.33	36.0	5.7	1000	120	160.0	H	105	17
475.001	30.12	36.0	5.9	1000	120	160.0	H	105	18
601.684	22.85	36.0	13.2	1000	120	160.0	H	41	20
699.979	28.50	36.0	7.5	1000	120	148.0	H	41	21
750.006	31.42	36.0	4.6	1000	120	160.0	H	241	22

Plot 6: 30 MHz to 1 GHz; vertical & horizontal polarization; U-NII-2C; middle channel

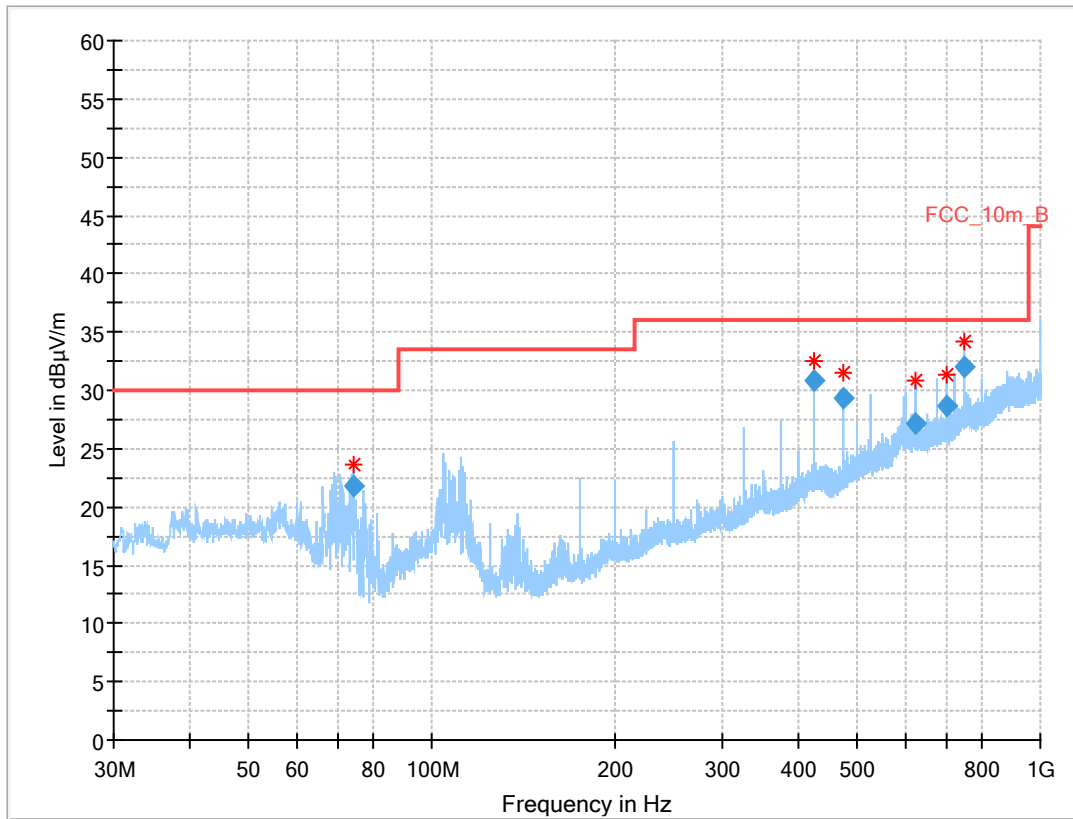

Results:

Frequency (MHz)	QuasiPeak (dBµV/m)	Limit (dBµV/m)	Margin (dB)	Meas. Time (ms)	Bandwidth (kHz)	Height (cm)	Pol	Azimuth (deg)	Corr. (dB)
74.565	21.83	30.0	8.2	1000	120	160.0	V	355	8
424.999	30.79	36.0	5.2	1000	120	153.0	H	87	17
475.002	29.39	36.0	6.6	1000	120	160.0	H	115	18
624.982	27.18	36.0	8.8	1000	120	160.0	H	55	21
700.014	28.72	36.0	7.3	1000	120	148.0	H	38	21
749.996	32.01	36.0	4.0	1000	120	133.0	H	231	22

Plot 7: 30 MHz to 1 GHz; vertical & horizontal polarization; U-NII-2C; highest channel

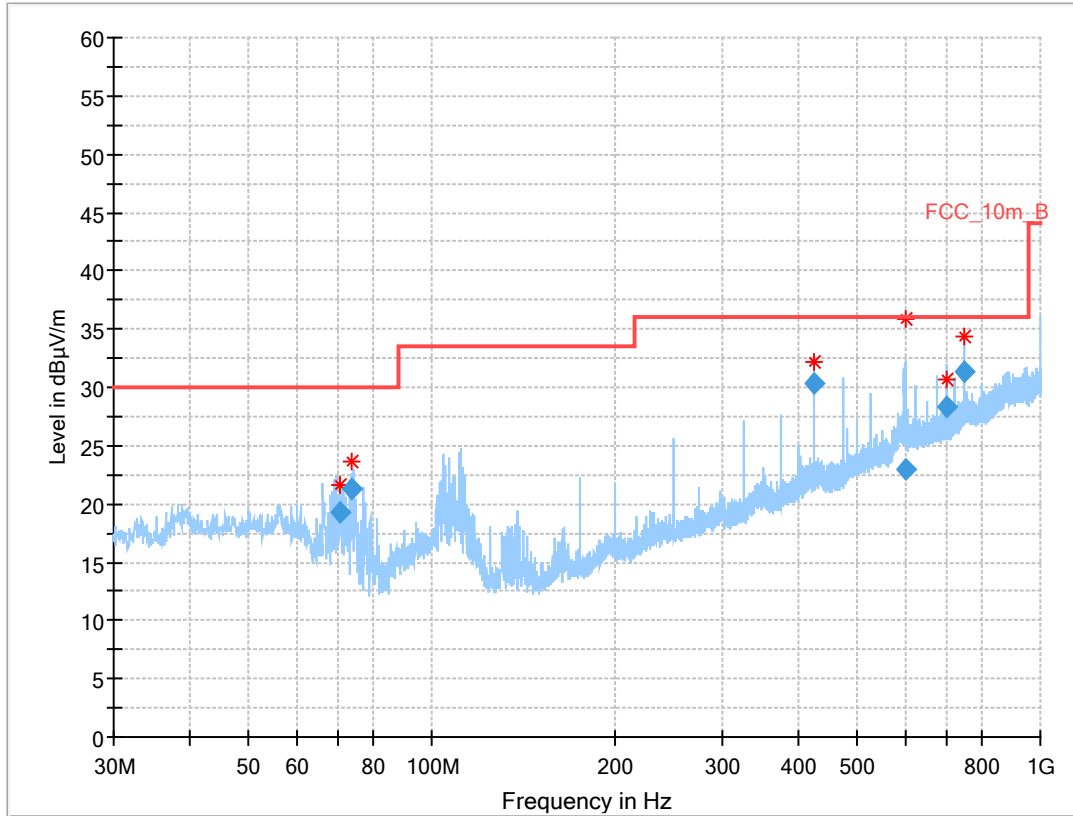

Results:

Frequency (MHz)	QuasiPeak (dBµV/m)	Limit (dBµV/m)	Margin (dB)	Meas. Time (ms)	Bandwidth (kHz)	Height (cm)	Pol	Azimuth (deg)	Corr. (dB)
70.837	19.19	30.0	10.8	1000	120	102.0	V	355	9
73.938	21.28	30.0	8.7	1000	120	160.0	V	342	8
425.016	30.40	36.0	5.6	1000	120	160.0	H	90	17
601.690	22.97	36.0	13.0	1000	120	160.0	H	55	20
700.006	28.34	36.0	7.7	1000	120	151.0	H	45	21
750.007	31.27	36.0	4.7	1000	120	114.0	H	227	22

Plot 8: 30 MHz to 1 GHz; vertical & horizontal polarization; U-NII-3; lowest channel

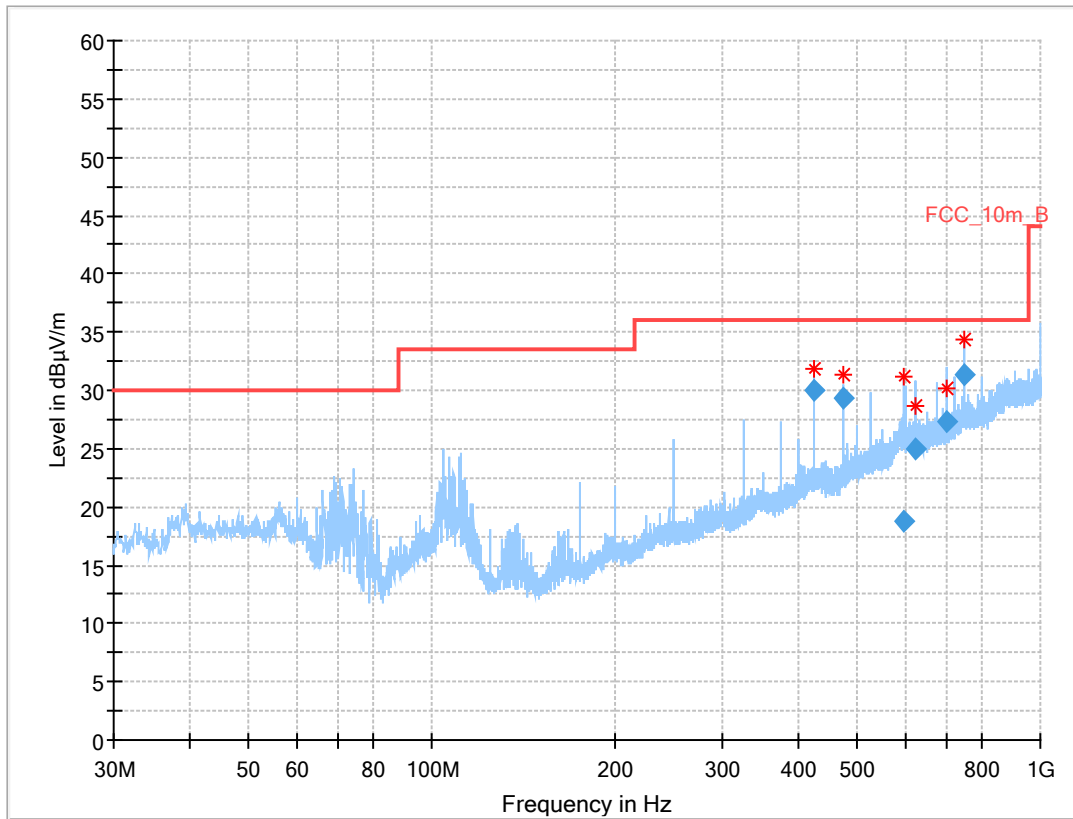

Results:

Frequency (MHz)	QuasiPeak (dBµV/m)	Limit (dBµV/m)	Margin (dB)	Meas. Time (ms)	Bandwidth (kHz)	Height (cm)	Pol	Azimuth (deg)	Corr. (dB)
425.005	29.99	36.0	6.0	1000	120	160.0	H	74	17
474.997	29.40	36.0	6.6	1000	120	160.0	H	111	18
598.334	18.75	36.0	17.3	1000	120	160.0	H	84	20
625.004	24.94	36.0	11.1	1000	120	160.0	H	95	21
700.006	27.39	36.0	8.6	1000	120	150.0	H	52	21
749.994	31.26	36.0	4.7	1000	120	160.0	H	231	22

Plot 9: 30 MHz to 1 GHz; vertical & horizontal polarization; U-NII-3; highest channel

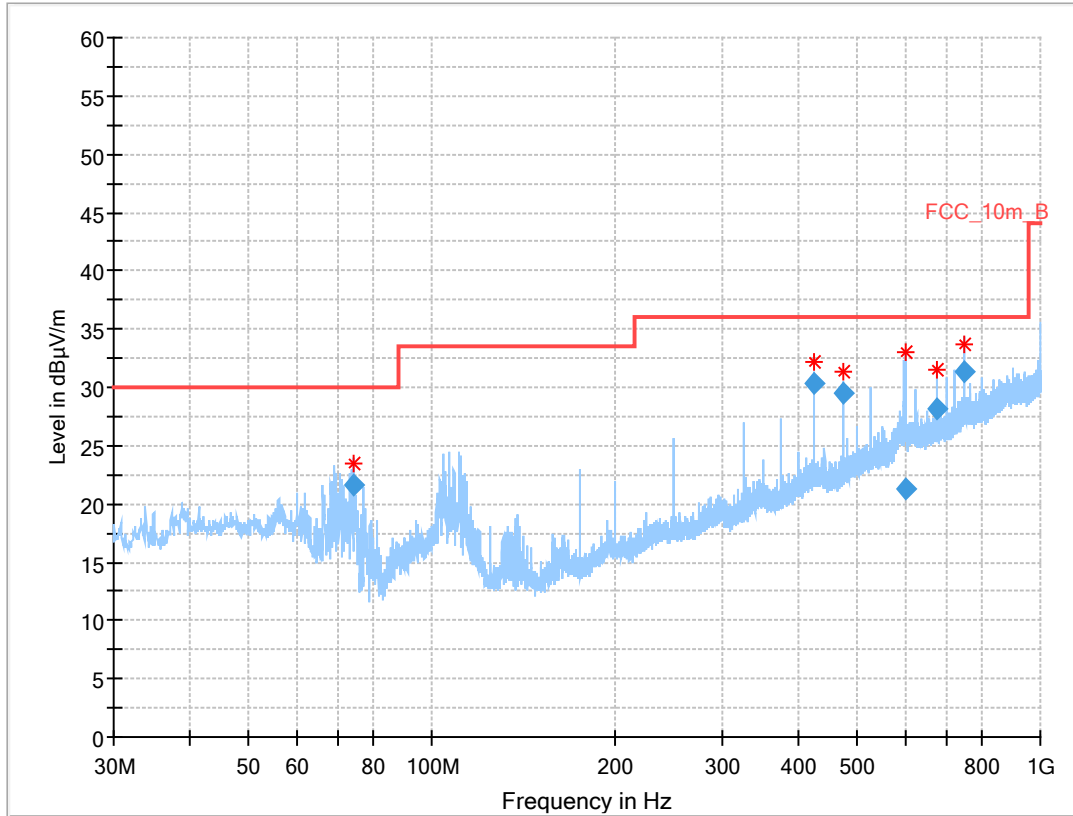

Results:

Frequency (MHz)	QuasiPeak (dBµV/m)	Limit (dBµV/m)	Margin (dB)	Meas. Time (ms)	Bandwidth (kHz)	Height (cm)	Pol	Azimuth (deg)	Corr. (dB)
74.551	21.62	30.0	8.4	1000	120	160.0	V	355	8
425.017	30.31	36.0	5.7	1000	120	160.0	H	91	17
474.985	29.52	36.0	6.5	1000	120	160.0	H	97	18
601.646	21.30	36.0	14.7	1000	120	149.0	H	69	20
674.996	28.11	36.0	7.9	1000	120	160.0	H	47	21
749.990	31.29	36.0	4.7	1000	120	127.0	H	146	22

Plot 13: 30 MHz to 1 GHz, cabinet radiation, vertical & horizontal polarization

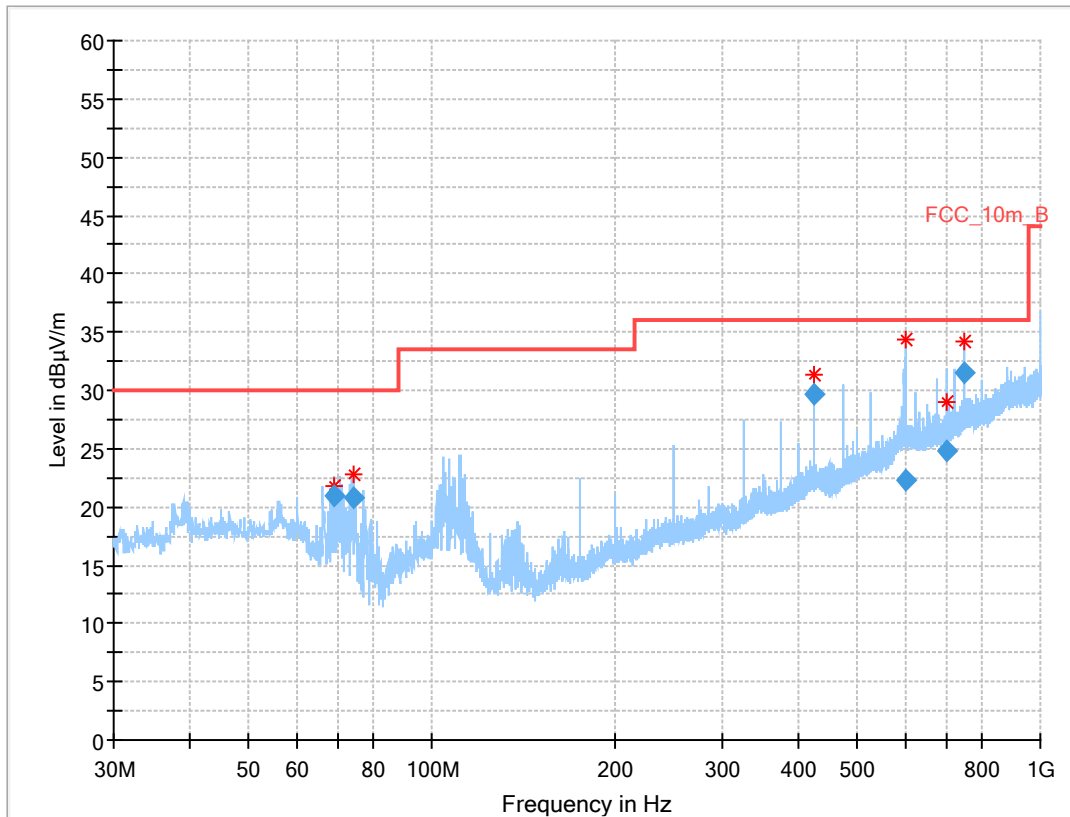

Results:

Frequency (MHz)	QuasiPeak (dBµV/m)	Limit (dBµV/m)	Margin (dB)	Meas. Time (ms)	Bandwidth (kHz)	Height (cm)	Pol	Azimuth (deg)	Corr. (dB)
68.990	20.89	30.0	9.1	1000	120	114.0	V	136	10
74.564	20.83	30.0	9.2	1000	120	160.0	V	196	8
424.997	29.62	36.0	6.4	1000	120	160.0	H	64	17
601.660	22.29	36.0	13.7	1000	120	160.0	H	64	20
699.973	24.76	36.0	11.2	1000	120	160.0	H	58	21
749.989	31.55	36.0	4.5	1000	120	160.0	H	228	22

11.12 Spurious emissions radiated 1 GHz to 40 GHz

Description:

Measurement of the radiated spurious emissions and cabinet radiations from 1 GHz to 40 GHz.

Measurement:

Measurement parameter	
Detector:	Quasi Peak below 1 GHz (alternative Peak) Peak above 1 GHz / RMS
Sweep time:	Auto
Resolution bandwidth:	1 MHz
Video bandwidth:	3 MHz
Span:	1 GHz to 40 GHz
Trace mode:	Max Hold / Average with 100 counts + 20 log (1 / X) for duty cycle lower than 100 %
Test setup:	See sub clause 6.1 – A See sub clause 6.2 – B See sub clause 6.3 – A
Measurement uncertainty:	See chapter 8

Limits:

TX Spurious Emissions Radiated		
§15.209		
Frequency (MHz)	Field Strength (dBµV/m)	Measurement distance
Above 960	54.0	3
§15.407		
Outside the restricted bands!	-27 dBm / MHz	

Results: 20 MHz channel bandwidth

TX Spurious Emissions Radiated [dBµV/m] / dBm								
U-NII-1 (5150 MHz to 5250 MHz)								
Lowest channel			Middle channel			Highest channel		
F [MHz]	Detector	Level [dBµV/m]	F [MHz]	Detector	Level [dBµV/m]	F [MHz]	Detector	Level [dBµV/m]
	Peak			Peak			Peak	
	AVG			AVG			AVG	
	Peak			Peak			Peak	
	AVG			AVG			AVG	
For emissions above 18 GHz please take look at the plots.			For emissions above 18 GHz please take look at the plots.			For emissions above 18 GHz please take look at the plots.		

TX Spurious Emissions Radiated [dBµV/m] / dBm								
U-NII-2A (5250 MHz to 5350 MHz)								
Lowest channel			Middle channel			Highest channel		
F [MHz]	Detector	Level [dBµV/m]	F [MHz]	Detector	Level [dBµV/m]	F [MHz]	Detector	Level [dBµV/m]
	Peak			Peak		10642	Peak	53.1
	AVG			AVG			AVG	40.8
	Peak			Peak			Peak	
	AVG			AVG			AVG	
For emissions above 18 GHz please take look at the plots.			For emissions above 18 GHz please take look at the plots.			For emissions above 18 GHz please take look at the plots.		

TX Spurious Emissions Radiated [dBµV/m] / dBm								
U-NII-2C (5470 MHz to 5725 MHz)								
Lowest channel			Middle channel			Highest channel		
F [MHz]	Detector	Level [dBµV/m]	F [MHz]	Detector	Level [dBµV/m]	F [MHz]	Detector	Level [dBµV/m]
11000	Peak	52.7	11200	Peak	58.7	11400	Peak	63.2
	AVG	40.9		AVG	46.9		AVG	51.4
	Peak			Peak			Peak	
	AVG			AVG			AVG	
For emissions above 18 GHz please take look at the plots.			For emissions above 18 GHz please take look at the plots.			For emissions above 18 GHz please take look at the plots.		

TX Spurious Emissions Radiated [dBµV/m] / dBm								
U-NII-3 (5725 MHz to 5850 MHz)								
Lowest channel			Middle channel			Highest channel		
F [MHz]	Detector	Level [dBµV/m]	F [MHz]	Detector	Level [dBµV/m]	F [MHz]	Detector	Level [dBµV/m]
11491	Peak	61.0	11572	Peak	63.4	11652	Peak	61.4
	AVG	50.1		AVG	52.8		AVG	51.4
	Peak			Peak			Peak	
	AVG			AVG			AVG	
For emissions above 18 GHz please take look at the plots.			For emissions above 18 GHz please take look at the plots.			For emissions above 18 GHz please take look at the plots.		

Results: 40 MHz channel bandwidth

TX Spurious Emissions Radiated [dBµV/m] / dBm								
U-NII-1 (5150 MHz to 5250 MHz)								
Lowest channel			Middle channel			Highest channel		
F [MHz]	Detector	Level [dBµV/m]	F [MHz]	Detector	Level [dBµV/m]	F [MHz]	Detector	Level [dBµV/m]
	Peak			Peak			Peak	
	AVG			AVG			AVG	
	Peak			Peak			Peak	
	AVG			AVG			AVG	
For emissions above 18 GHz please take look at the plots.			For emissions above 18 GHz please take look at the plots.			For emissions above 18 GHz please take look at the plots.		

TX Spurious Emissions Radiated [dBµV/m] / dBm								
U-NII-2A (5250 MHz to 5350 MHz)								
Lowest channel			Middle channel			Highest channel		
F [MHz]	Detector	Level [dBµV/m]	F [MHz]	Detector	Level [dBµV/m]	F [MHz]	Detector	Level [dBµV/m]
	Peak			Peak			Peak	
	AVG			AVG			AVG	
	Peak			Peak			Peak	
	AVG			AVG			AVG	
For emissions above 18 GHz please take look at the plots.			For emissions above 18 GHz please take look at the plots.			For emissions above 18 GHz please take look at the plots.		

TX Spurious Emissions Radiated [dBµV/m] / dBm								
U-NII-2C (5470 MHz to 5725 MHz)								
Lowest channel			Middle channel			Highest channel		
F [MHz]	Detector	Level [dBµV/m]	F [MHz]	Detector	Level [dBµV/m]	F [MHz]	Detector	Level [dBµV/m]
	Peak			Peak			Peak	
	AVG			AVG			AVG	
	Peak			Peak			Peak	
	AVG			AVG			AVG	
For emissions above 18 GHz please take look at the plots.			For emissions above 18 GHz please take look at the plots.			For emissions above 18 GHz please take look at the plots.		

TX Spurious Emissions Radiated [dBµV/m] / dBm								
U-NII-3 (5725 MHz to 5850 MHz)								
Lowest channel			Middle channel			Highest channel		
F [MHz]	Detector	Level [dBµV/m]	F [MHz]	Detector	Level [dBµV/m]	F [MHz]	Detector	Level [dBµV/m]
	Peak			Peak			Peak	
	AVG			AVG			AVG	
	Peak			Peak			Peak	
	AVG			AVG			AVG	
For emissions above 18 GHz please take look at the plots.			For emissions above 18 GHz please take look at the plots.			For emissions above 18 GHz please take look at the plots.		

Plots: 20 MHz channel bandwidth

Plot 1: 1 GHz to 18 GHz; vertical & horizontal polarization; U-NII-1; lowest channel

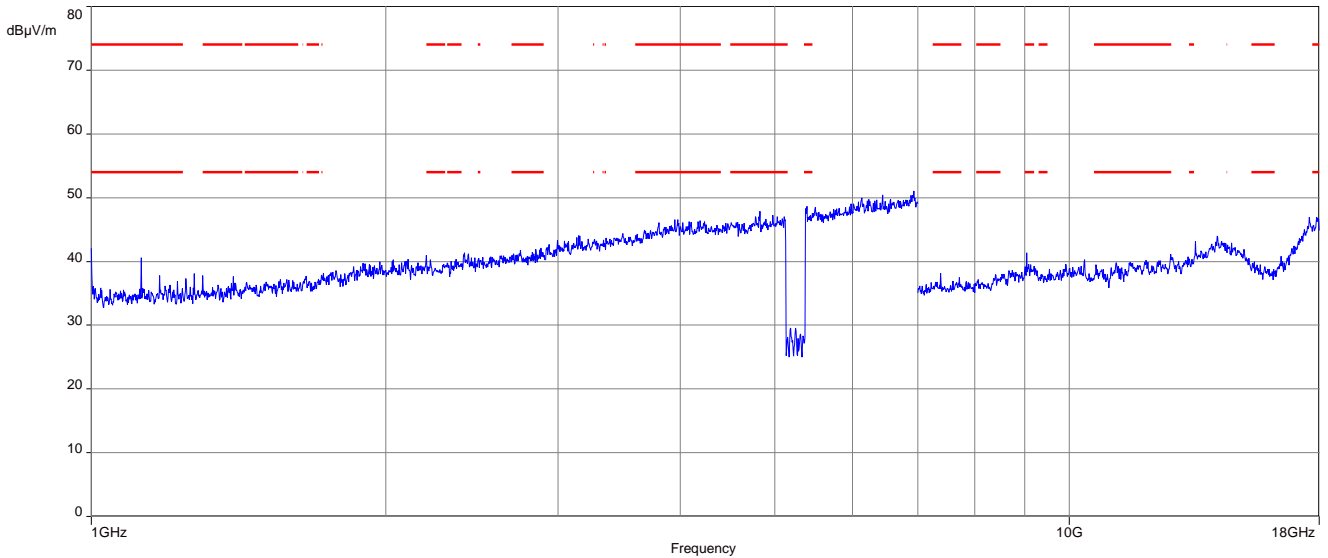

NOTE: The carrier signal is notched.

Plot 2: 18 GHz to 26 GHz; vertical & horizontal polarization; U-NII-1; lowest channel

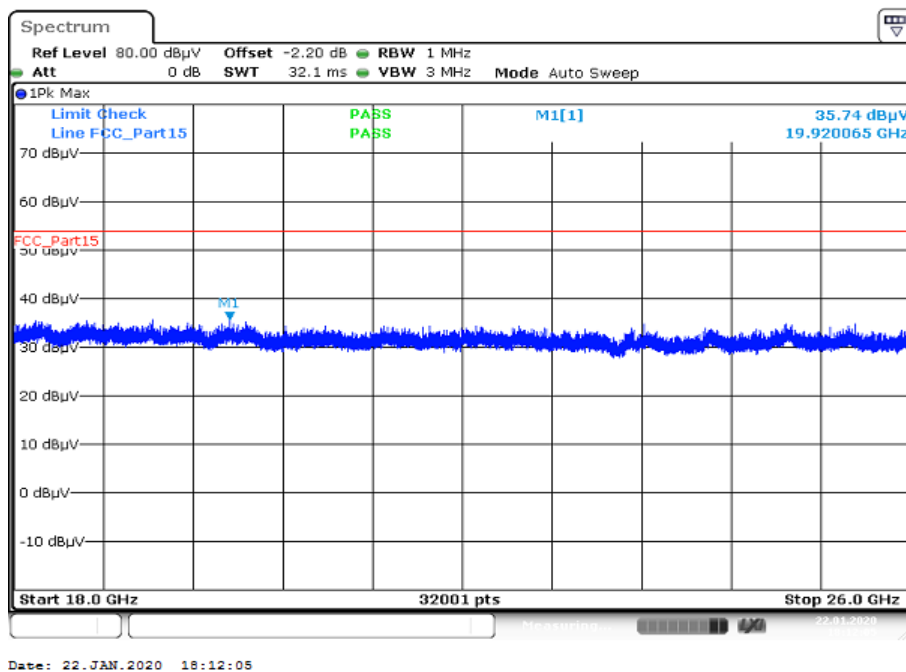

Plot 3: 26 GHz to 40 GHz; vertical & horizontal polarization; U-NII-1; lowest channel

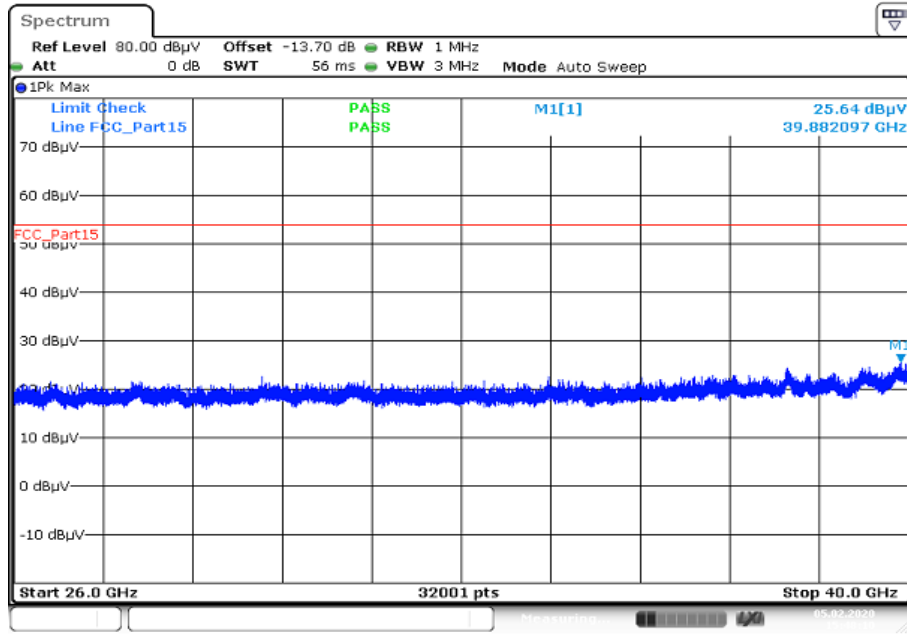

Date: 5. FEB. 2020 15:48:09

Plot 4: 1 GHz to 18 GHz; vertical & horizontal polarization; U-NII-1; highest channel

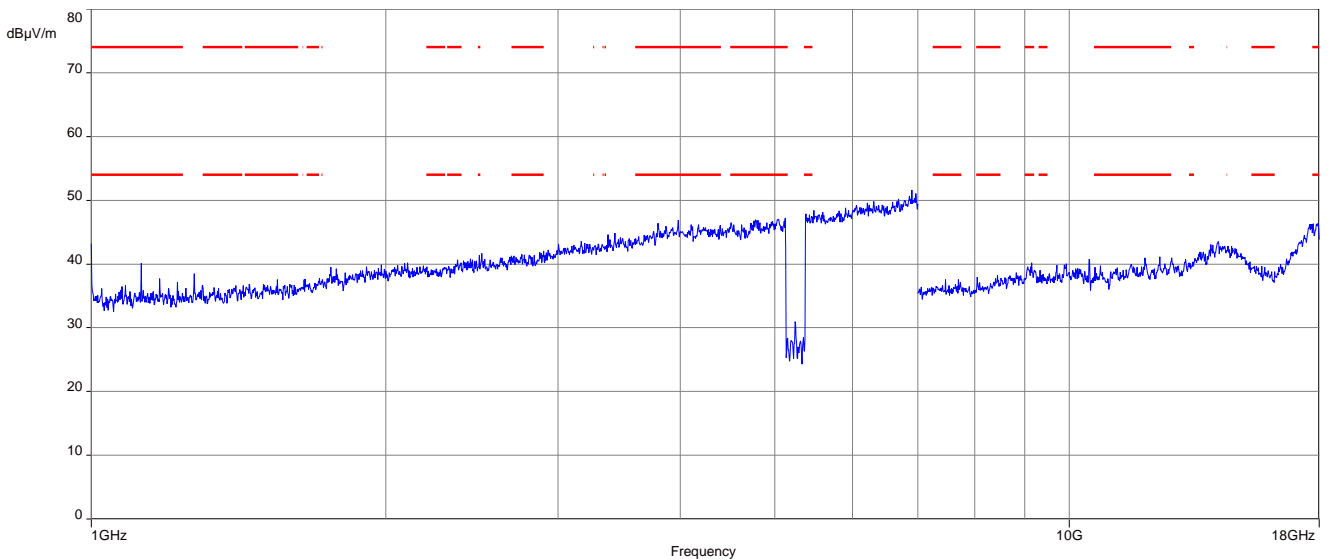

NOTE: The carrier signal is notched.

Plot 5: 18 GHz to 26 GHz; vertical & horizontal polarization; U-NII-1; highest channel

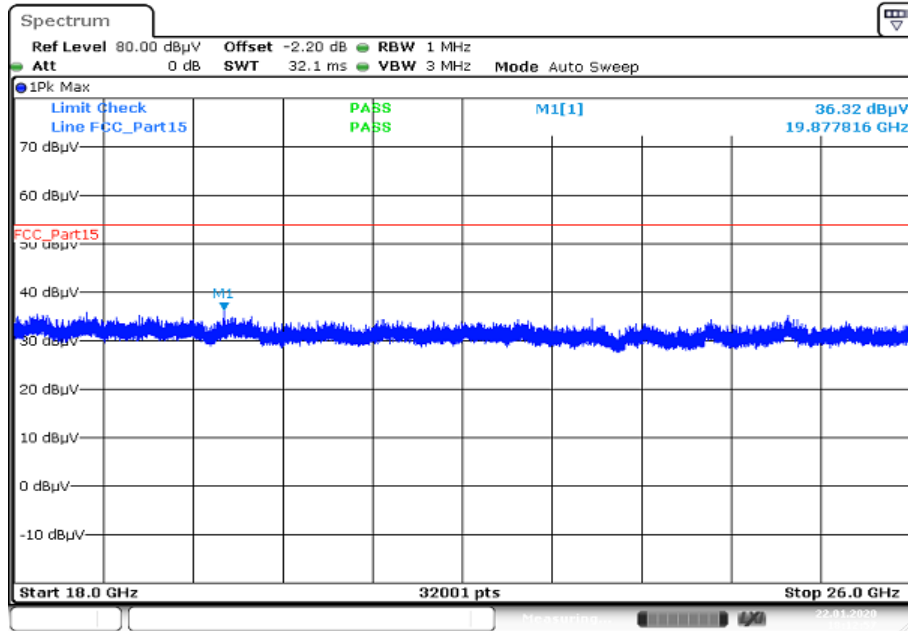

Plot 6: 26 GHz to 40 GHz; vertical & horizontal polarization; U-NII-1; highest channel

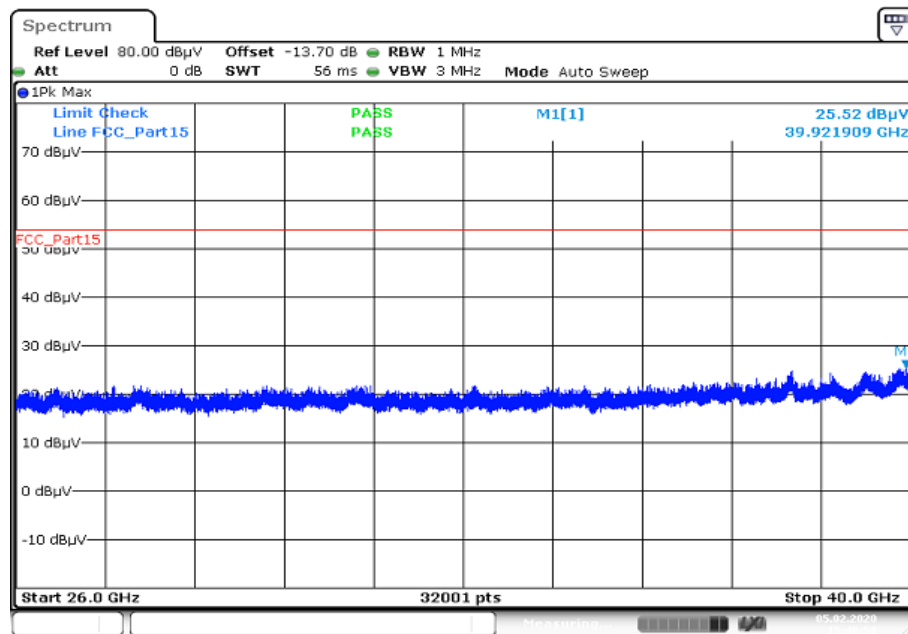

Plot 7: 1 GHz to 18 GHz; vertical & horizontal polarization; U-NII-2A; lowest channel

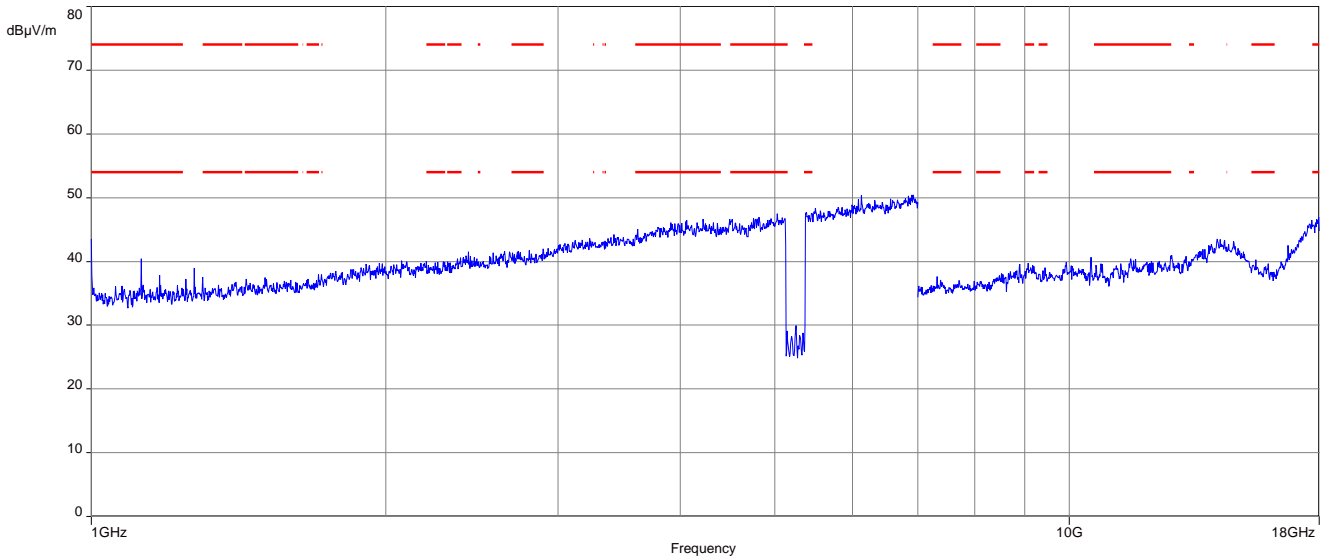

NOTE: The carrier signal is notched.

Plot 8: 18 GHz to 26 GHz; vertical & horizontal polarization; U-NII-2A; lowest channel

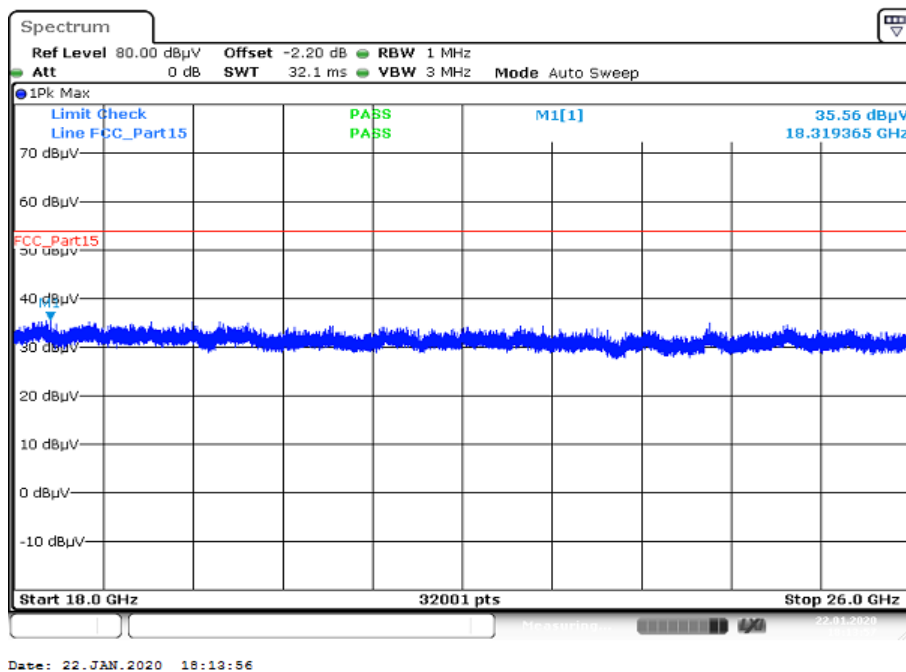

Plot 9: 26 GHz to 40 GHz; vertical & horizontal polarization; U-NII-2A; lowest channel

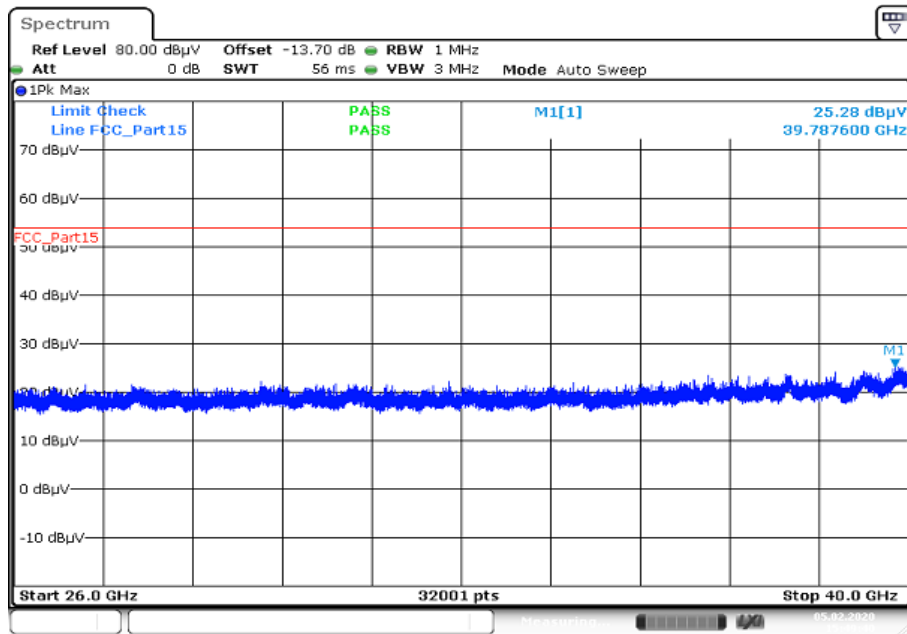

Date: 5. FEB. 2020 15:49:40

Plot 10: 1 GHz to 18 GHz; vertical & horizontal polarization; U-NII-2A; highest channel

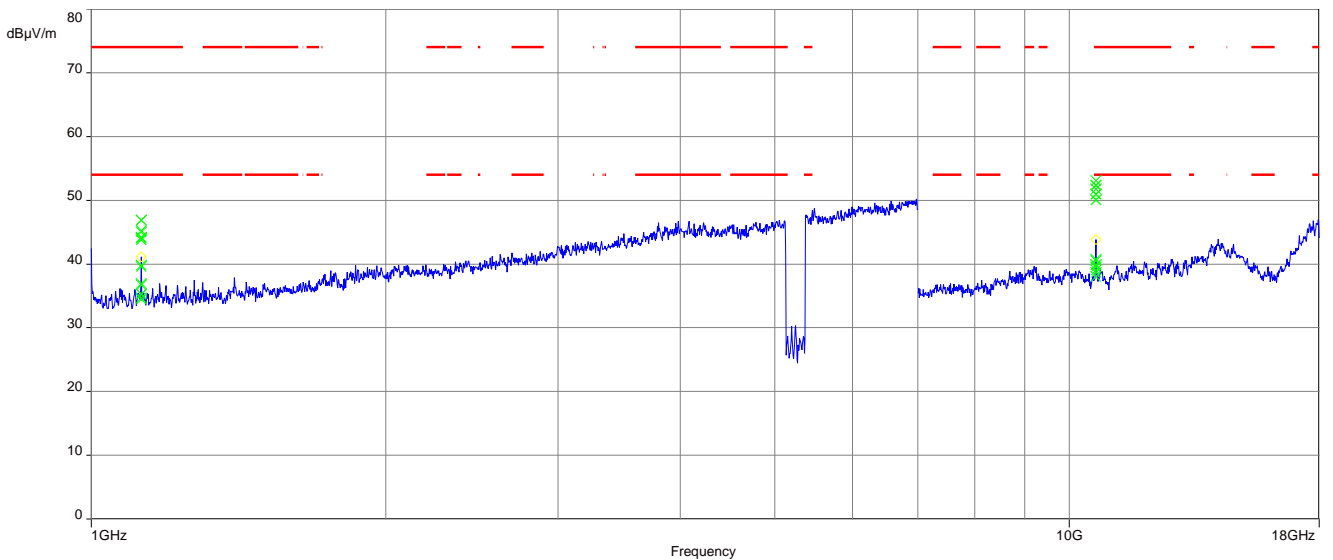

NOTE: The carrier signal is notched.

Plot 11: 18 GHz to 26 GHz; vertical & horizontal polarization; U-NII-2A; highest channel

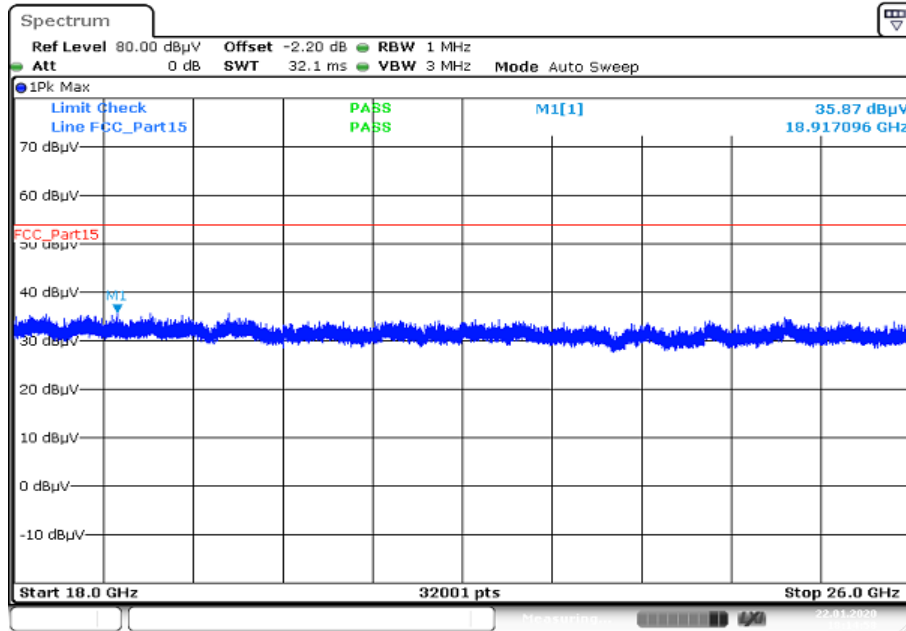

Plot 12: 26 GHz to 40 GHz; vertical & horizontal polarization; U-NII-2A; highest channel

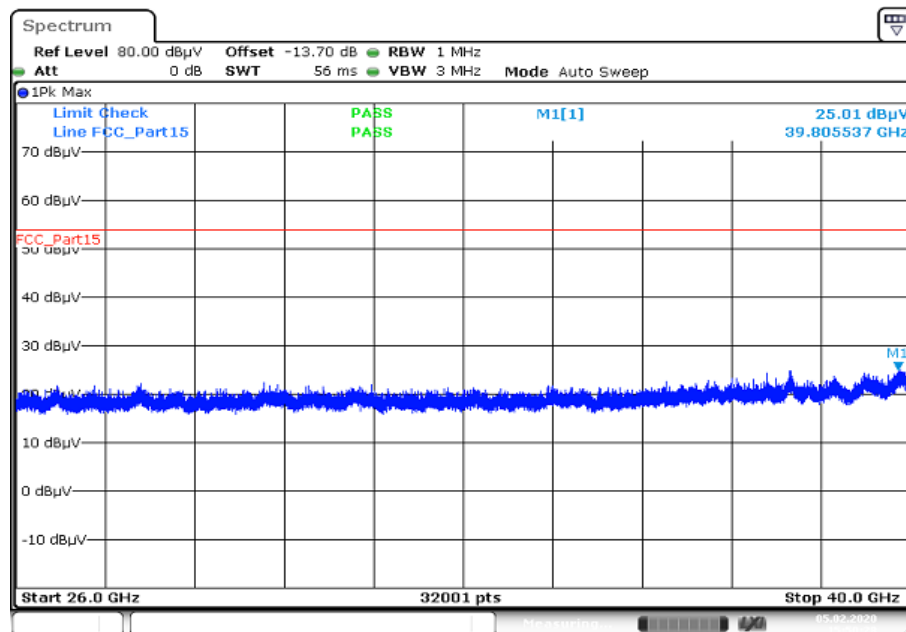

Plot 13: 1 GHz to 18 GHz; vertical & horizontal polarization; U-NII-2C; lowest channel

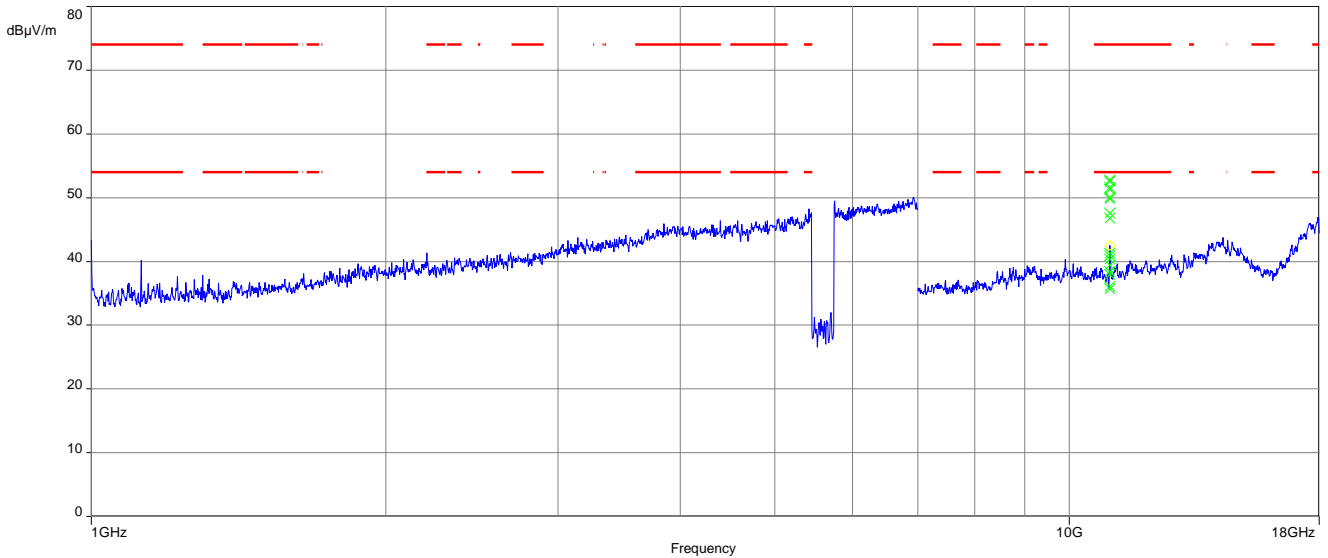

NOTE: The carrier signal is notched.

Plot 14: 18 GHz to 26 GHz; vertical & horizontal polarization; U-NII-2C; lowest channel

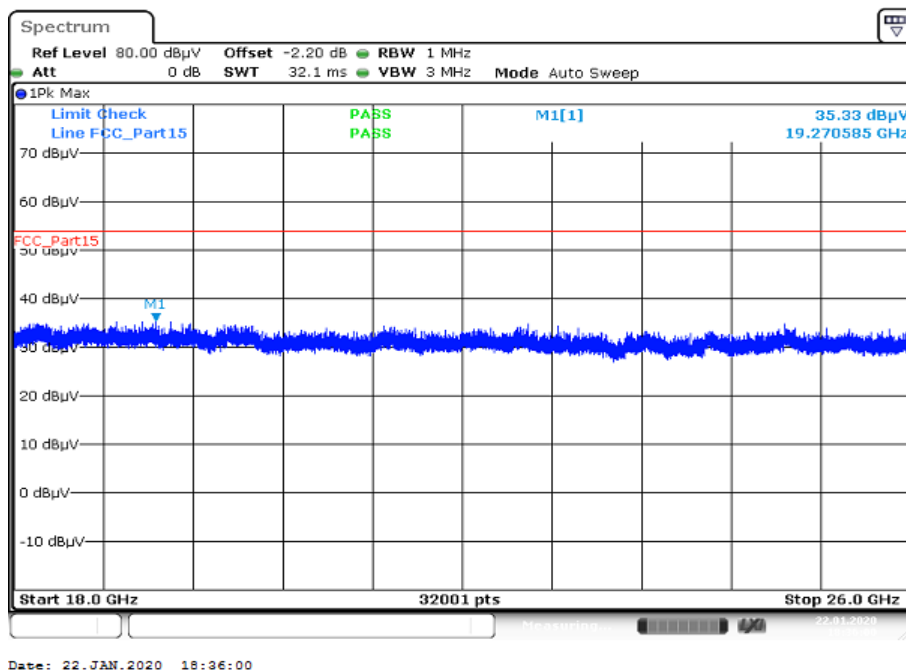

Plot 15: 26 GHz to 40 GHz; vertical & horizontal polarization; U-NII-2C; lowest channel

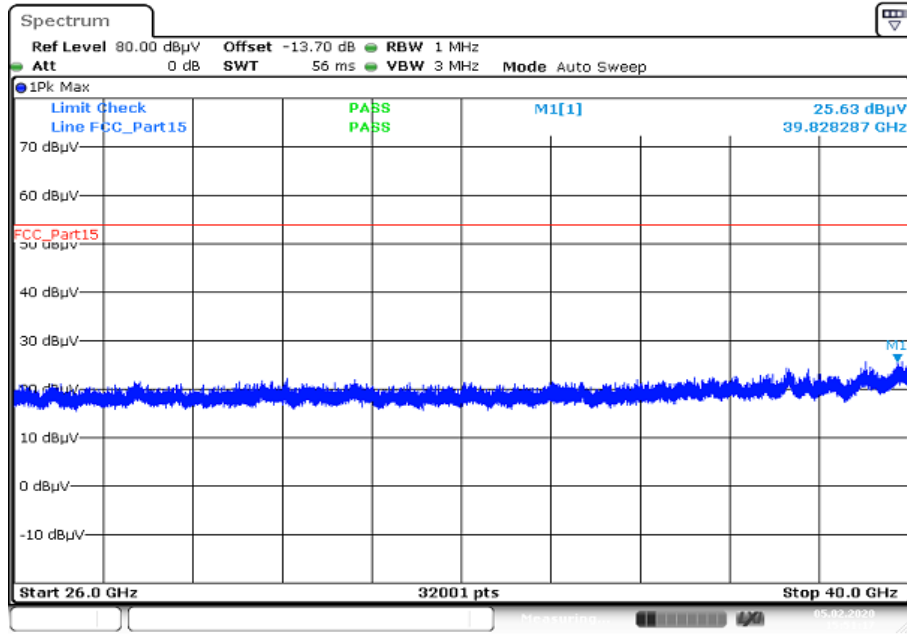

Date: 5. FEB. 2020 15:51:17

Plot 16: 1 GHz to 18 GHz; vertical & horizontal polarization; U-NII-2C; middle channel

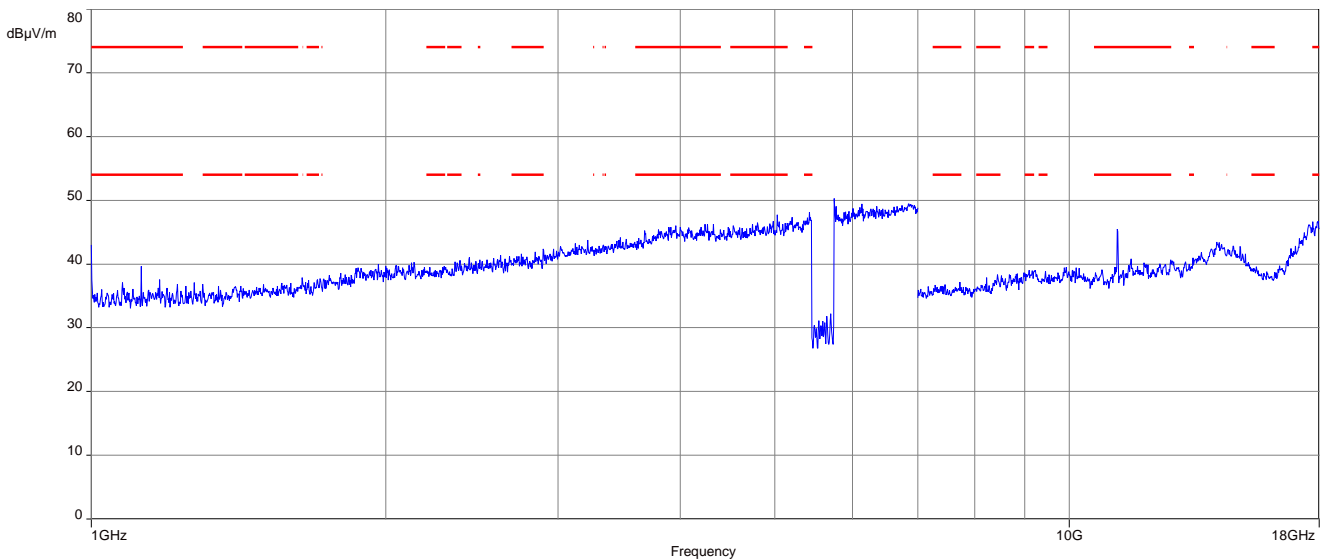

NOTE: The carrier signal is notched.

Plot 17: 18 GHz to 26 GHz; vertical & horizontal polarization; U-NII-2C; middle channel

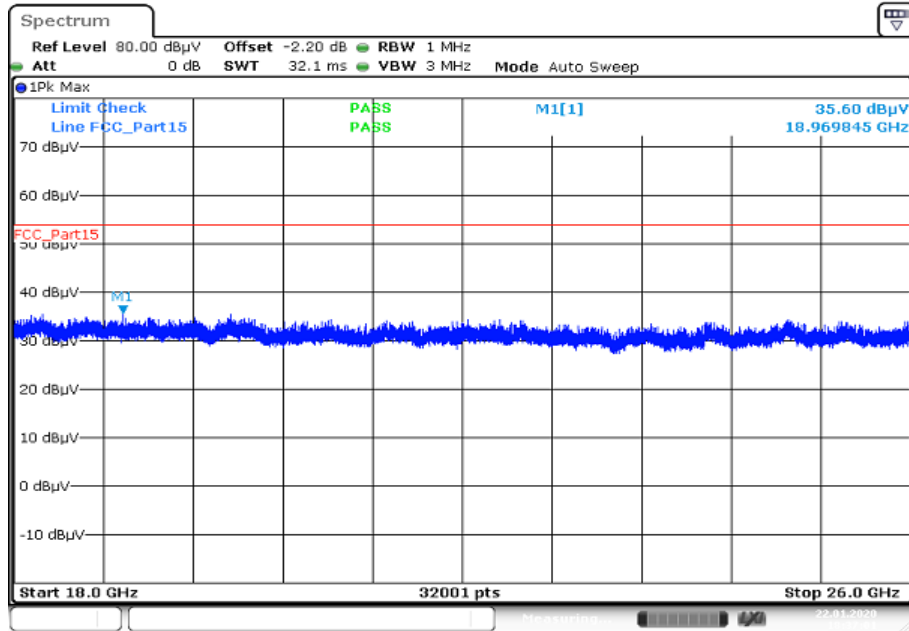

Plot 18: 26 GHz to 40 GHz; vertical & horizontal polarization; U-NII-2C; middle channel

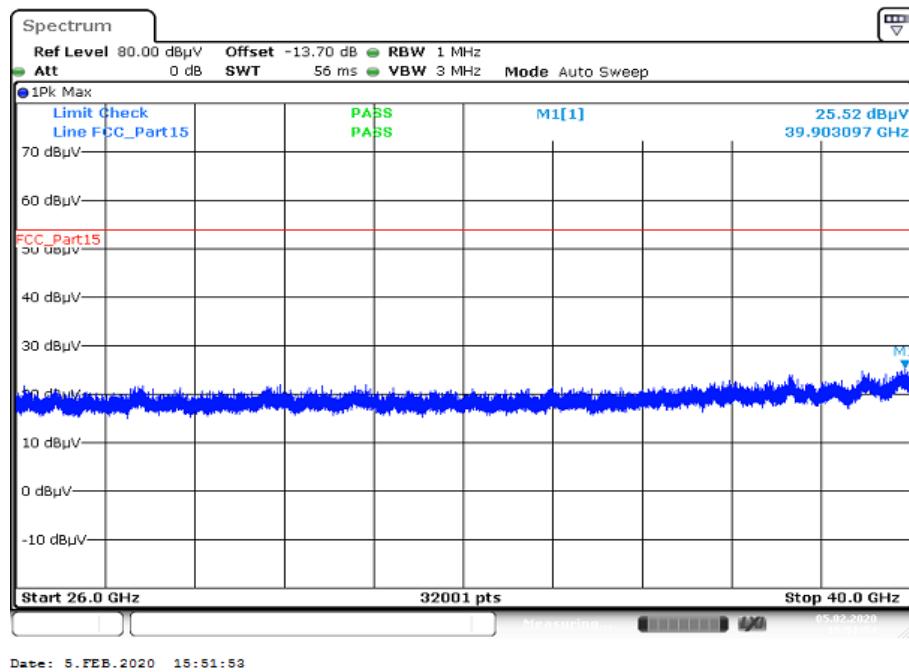

Plot 19: 1 GHz to 18 GHz; vertical & horizontal polarization; U-NII-2C; highest channel

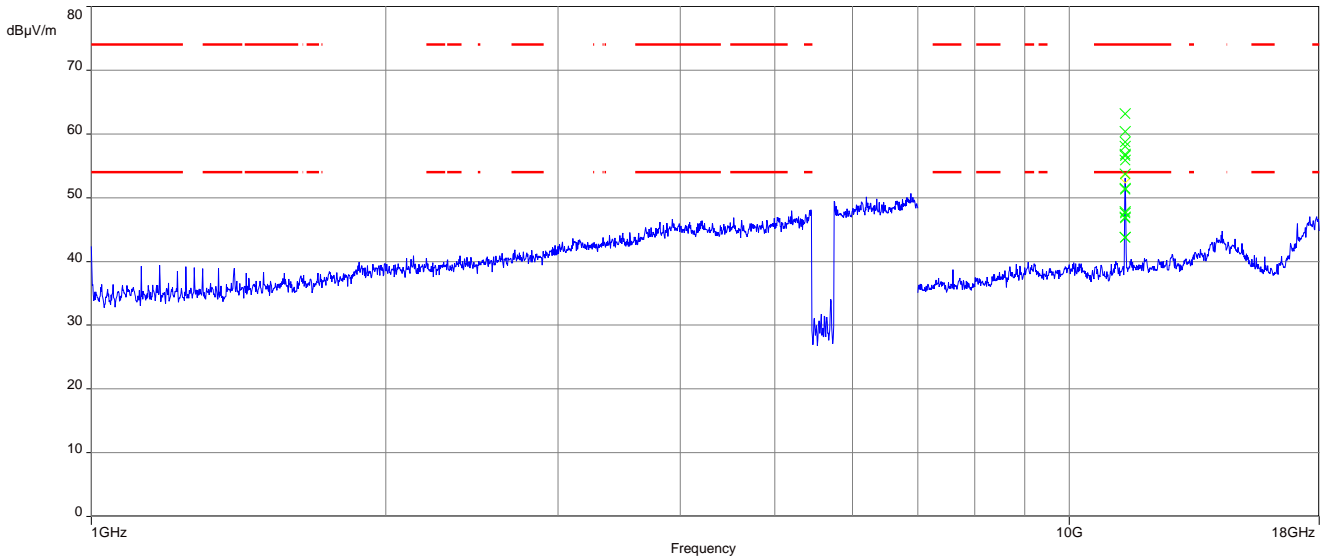

NOTE: The carrier signal is notched.

Plot 20: 18 GHz to 26 GHz; vertical & horizontal polarization; U-NII-2C; highest channel

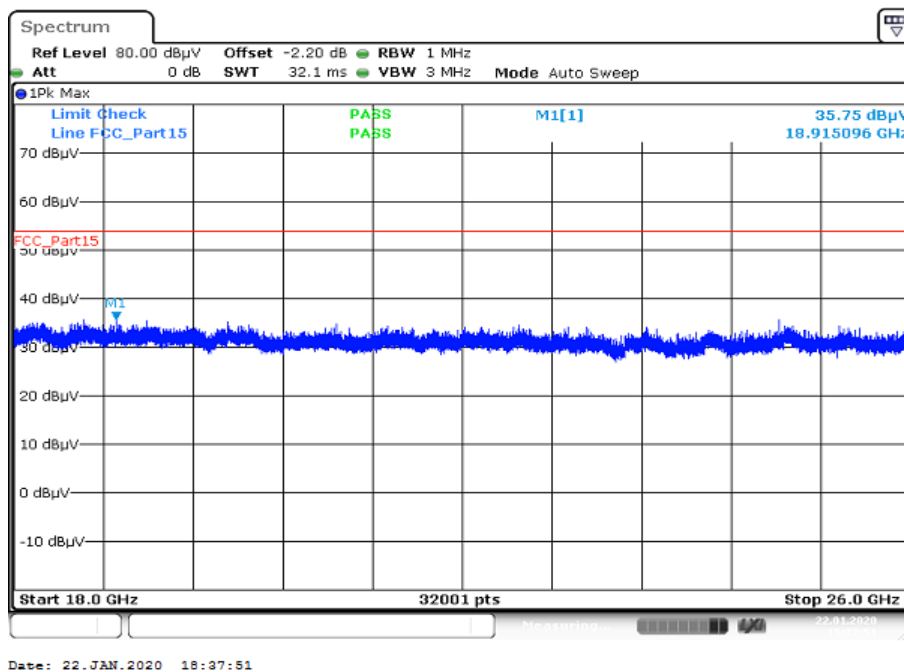

Plot 21: 26 GHz to 40 GHz; vertical & horizontal polarization; U-NII-2C; highest channel

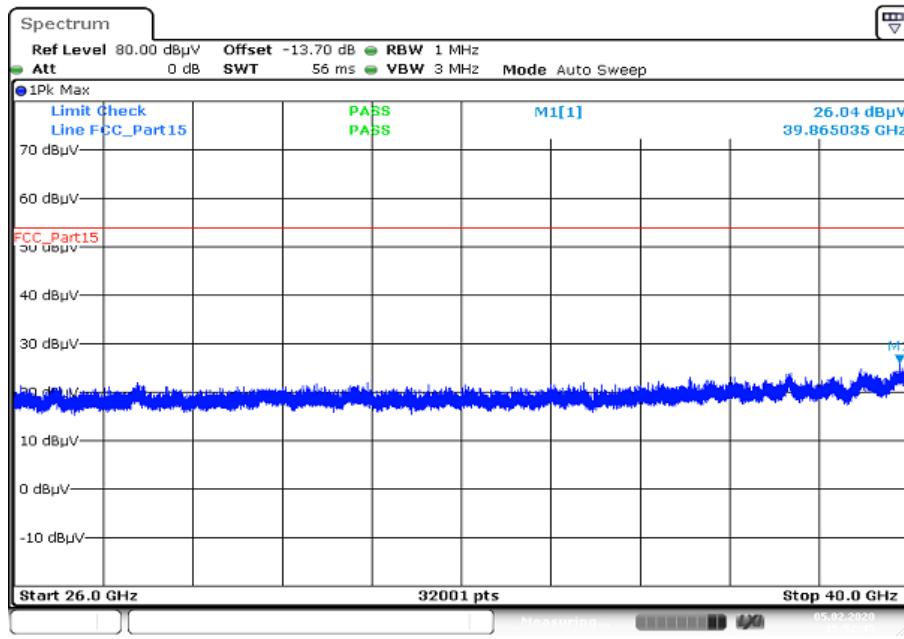

Plot 22: 1 GHz to 18 GHz; vertical & horizontal polarization; U-NII-3; lowest channel

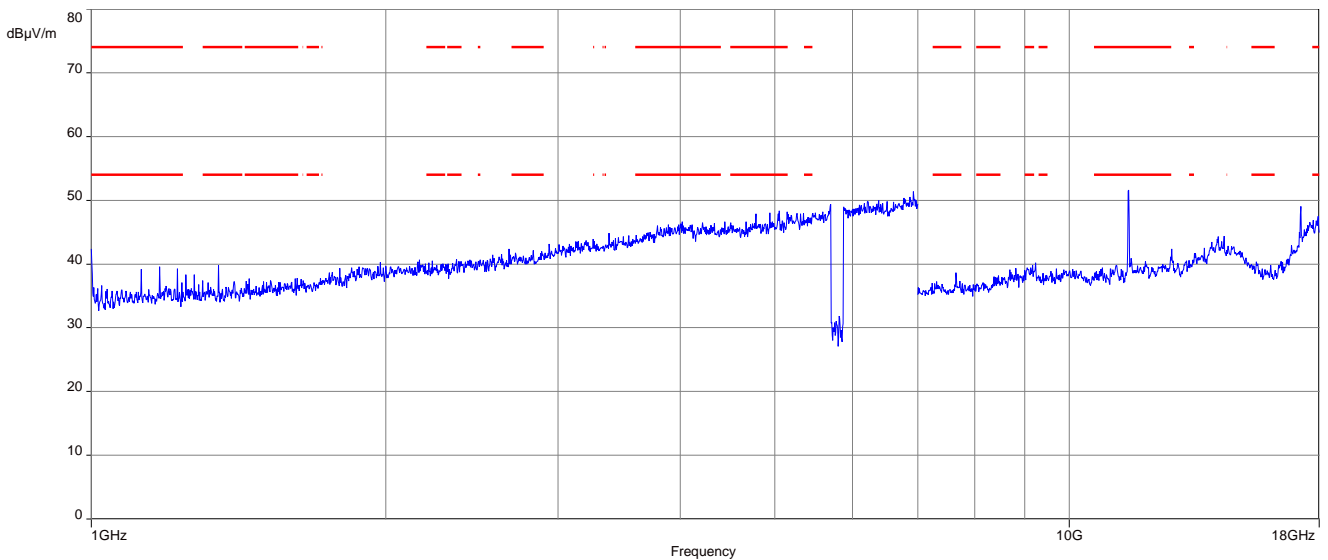

NOTE: The carrier signal is notched.

Plot 23: 18 GHz to 26 GHz; vertical & horizontal polarization; U-NII-3; lowest channel

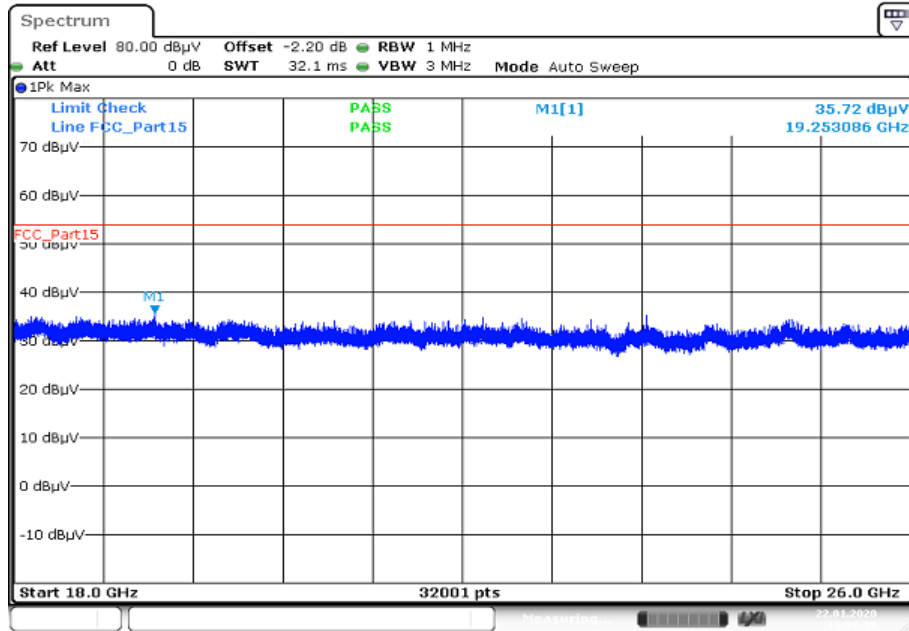

Plot 24: 26 GHz to 40 GHz; vertical & horizontal polarization; U-NII-3; lowest channel

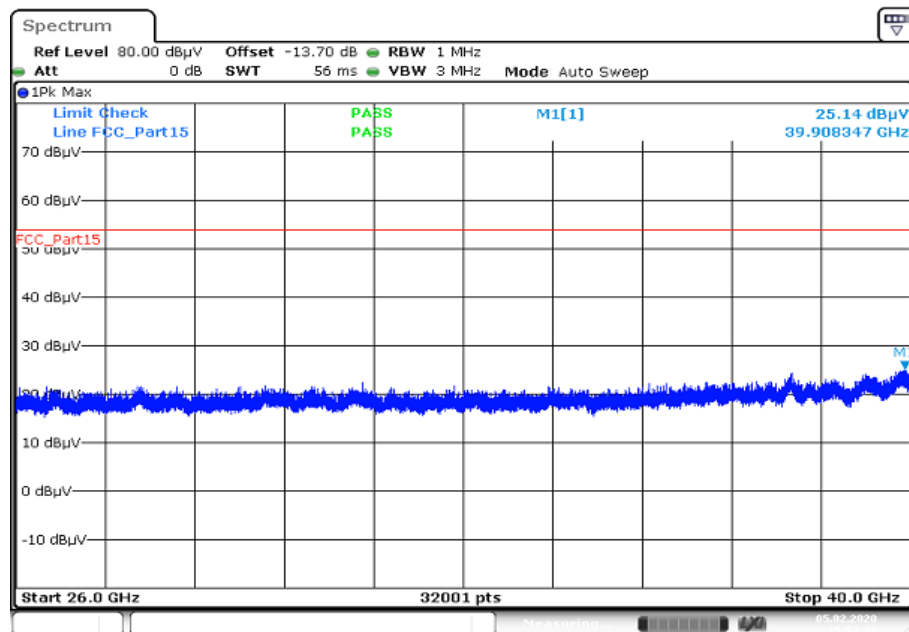

Plot 25: 1 GHz to 18 GHz; vertical & horizontal polarization; U-NII-3; middle channel

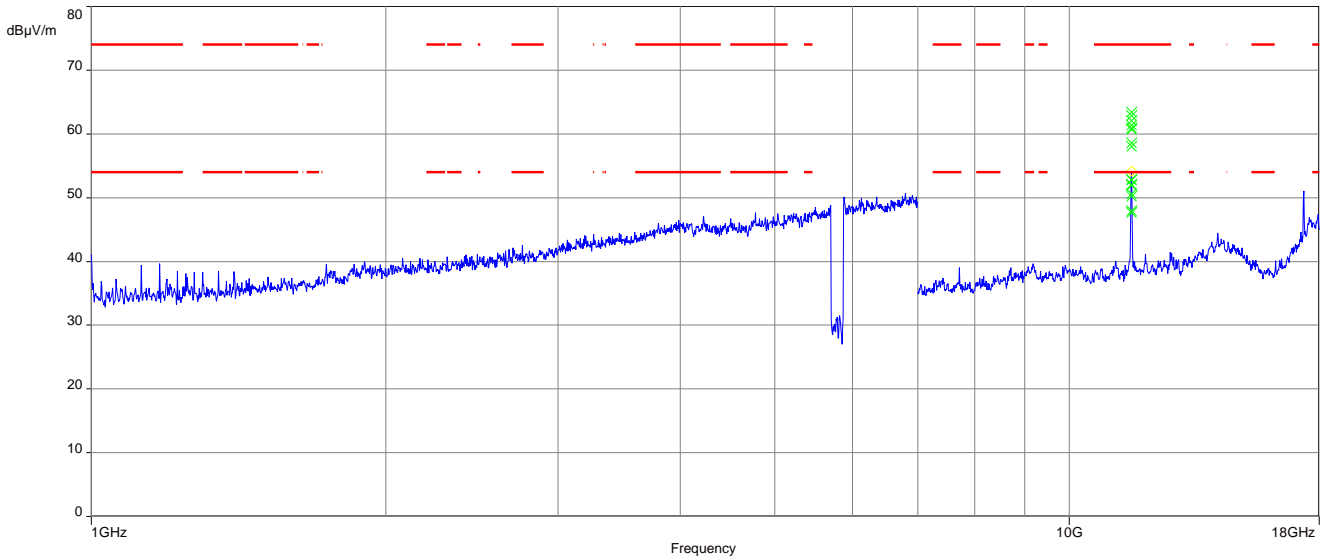

NOTE: The carrier signal is notched.

Plot 26: 18 GHz to 26 GHz; vertical & horizontal polarization; U-NII-3; middle channel

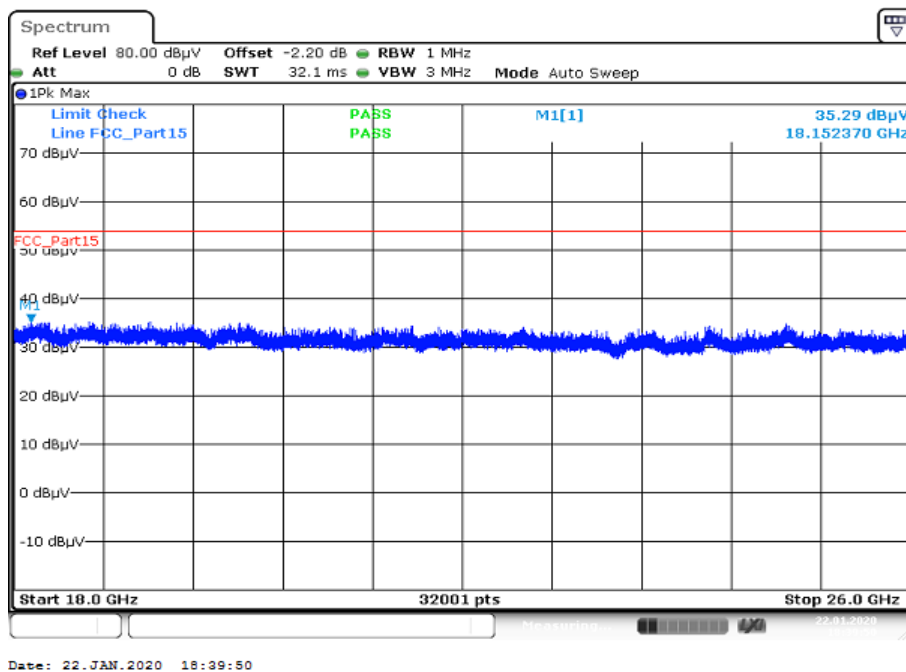

Plot 27: 26 GHz to 40 GHz; vertical & horizontal polarization; U-NII-3; middle channel

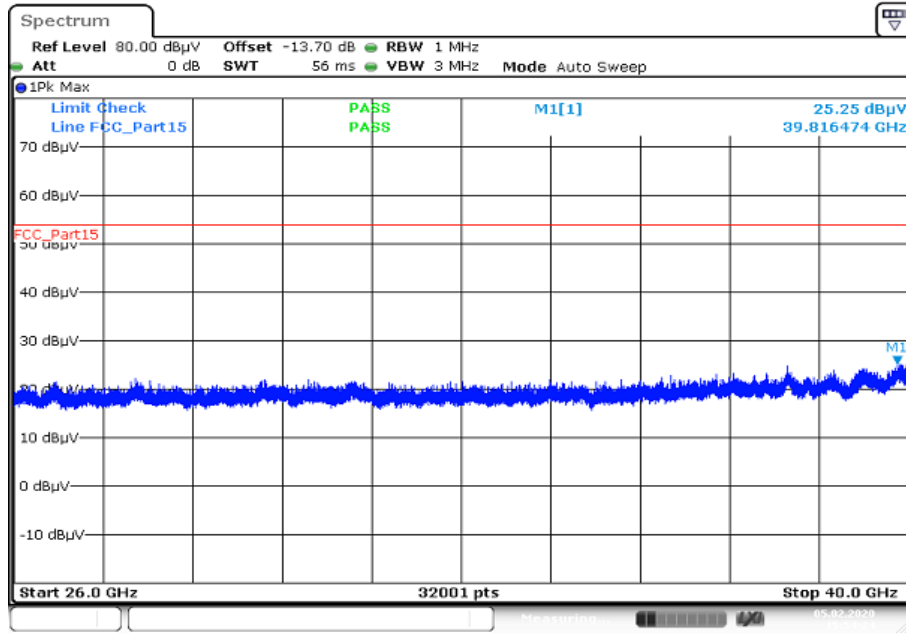

Date: 5. FEB. 2020 15:54:24

Plot 28: 1 GHz to 18 GHz; vertical & horizontal polarization; U-NII-3; highest channel

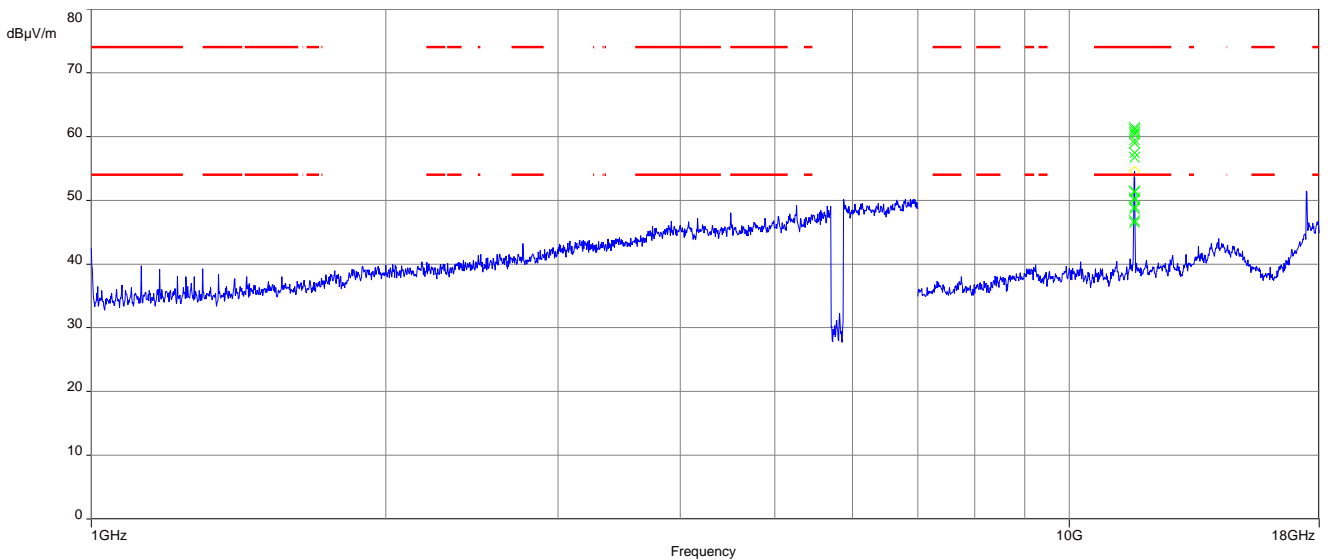

NOTE: The carrier signal is notched.

Plot 29: 18 GHz to 26 GHz; vertical & horizontal polarization; U-NII-3; highest channel

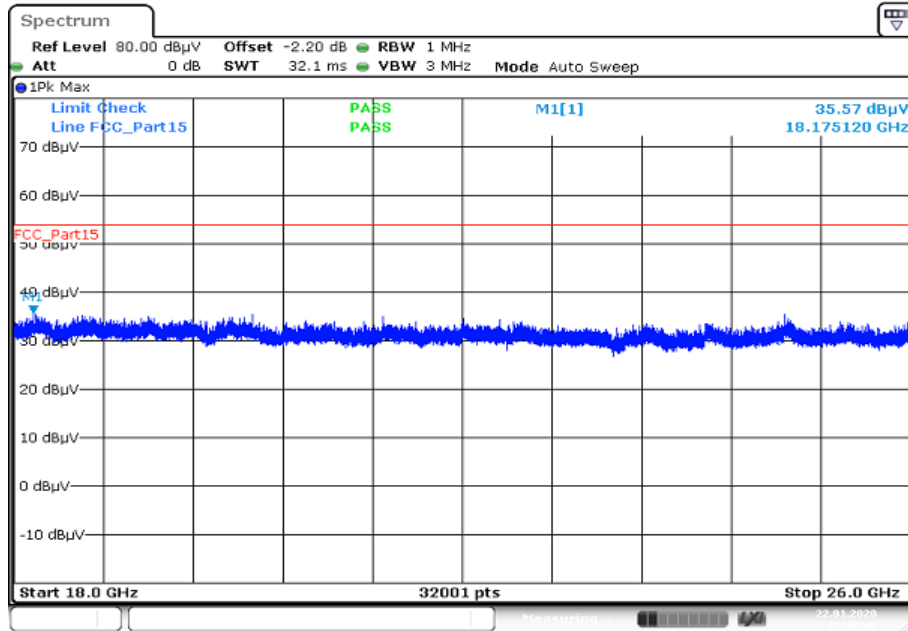

Plot 30: 26 GHz to 40 GHz; vertical & horizontal polarization; U-NII-3; highest channel

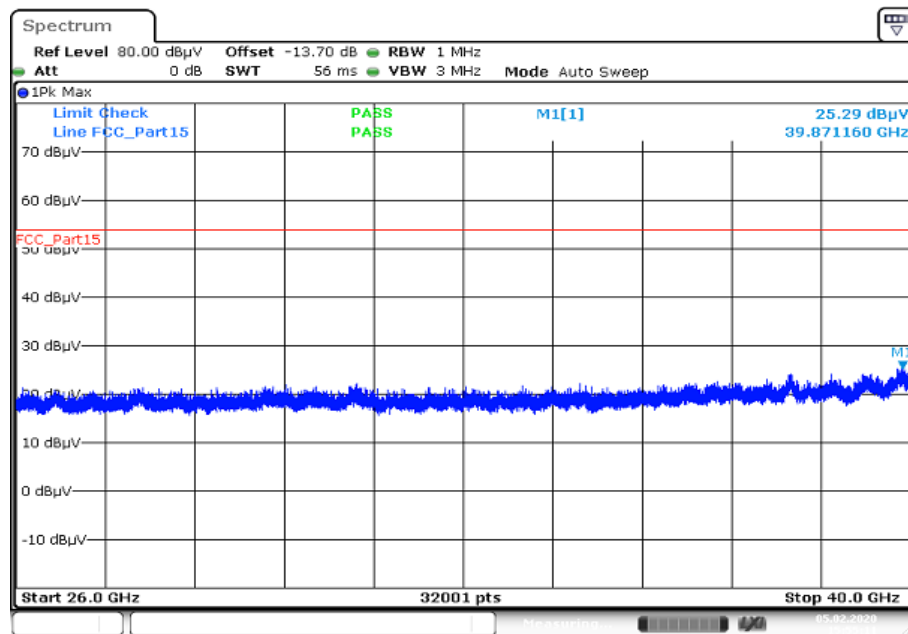

Plots: 40 MHz channel bandwidth

Plot 1: 1 GHz to 18 GHz; vertical & horizontal polarization; U-NII-1; lowest channel

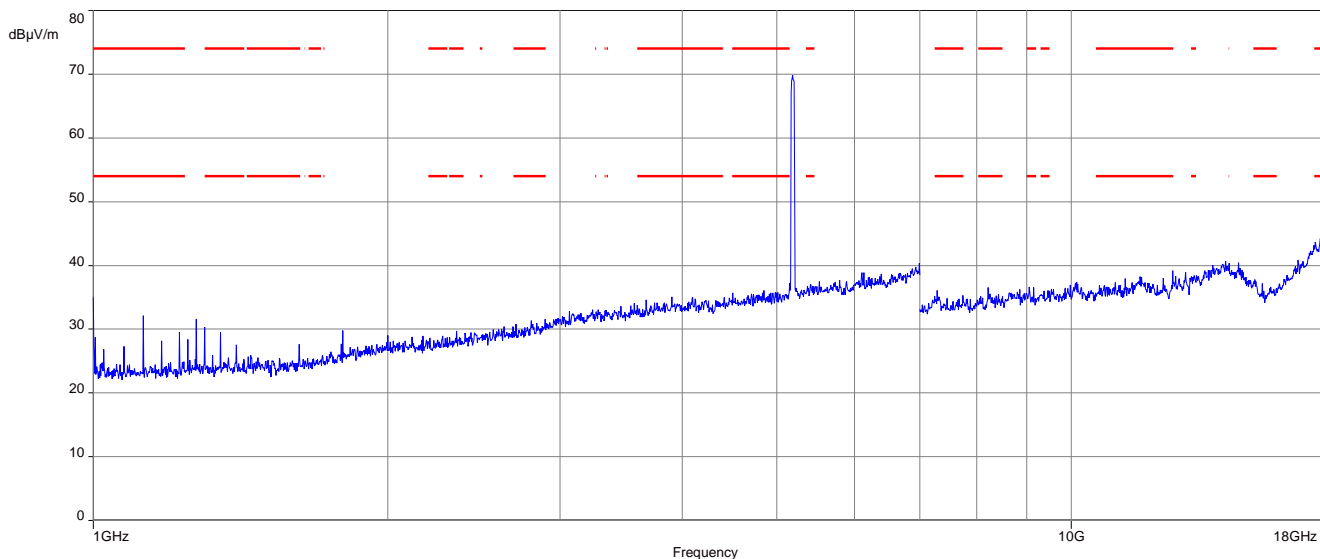

Plot 2: 18 GHz to 26 GHz; vertical & horizontal polarization; U-NII-1; lowest channel

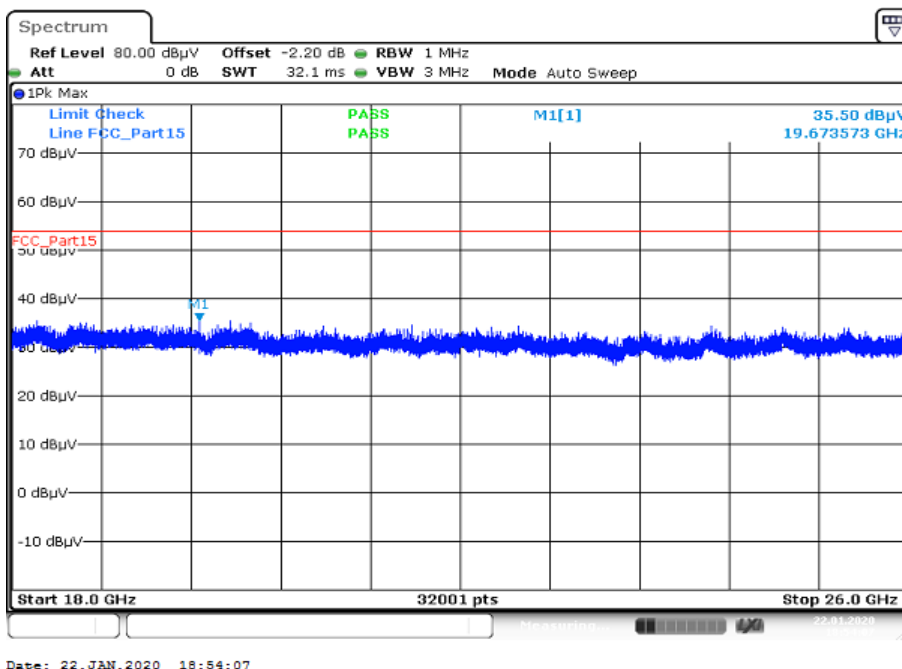

Plot 3: 26 GHz to 40 GHz; vertical & horizontal polarization; U-NII-1; lowest channel

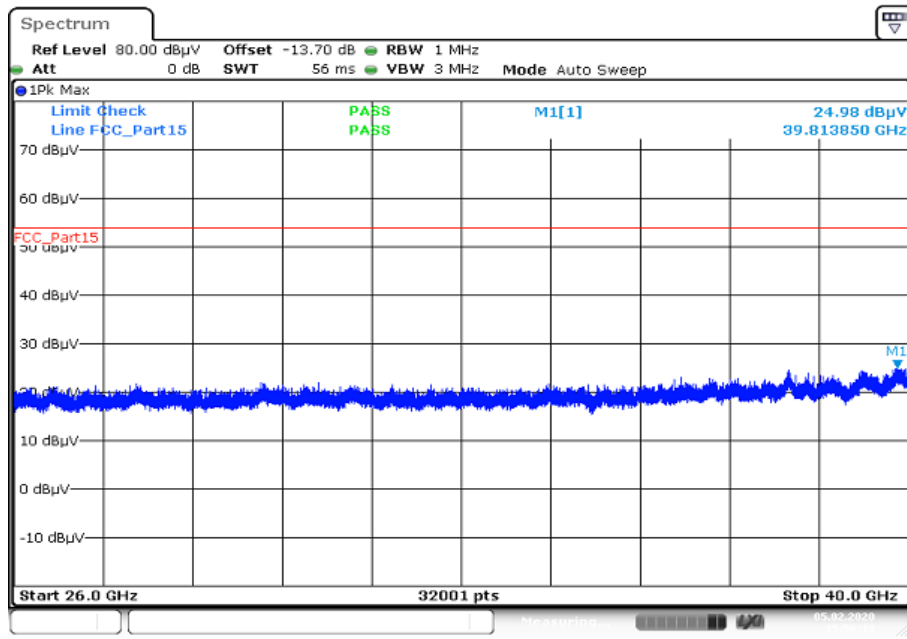

Plot 4: 1 GHz to 18 GHz; vertical & horizontal polarization; U-NII-1; highest channel

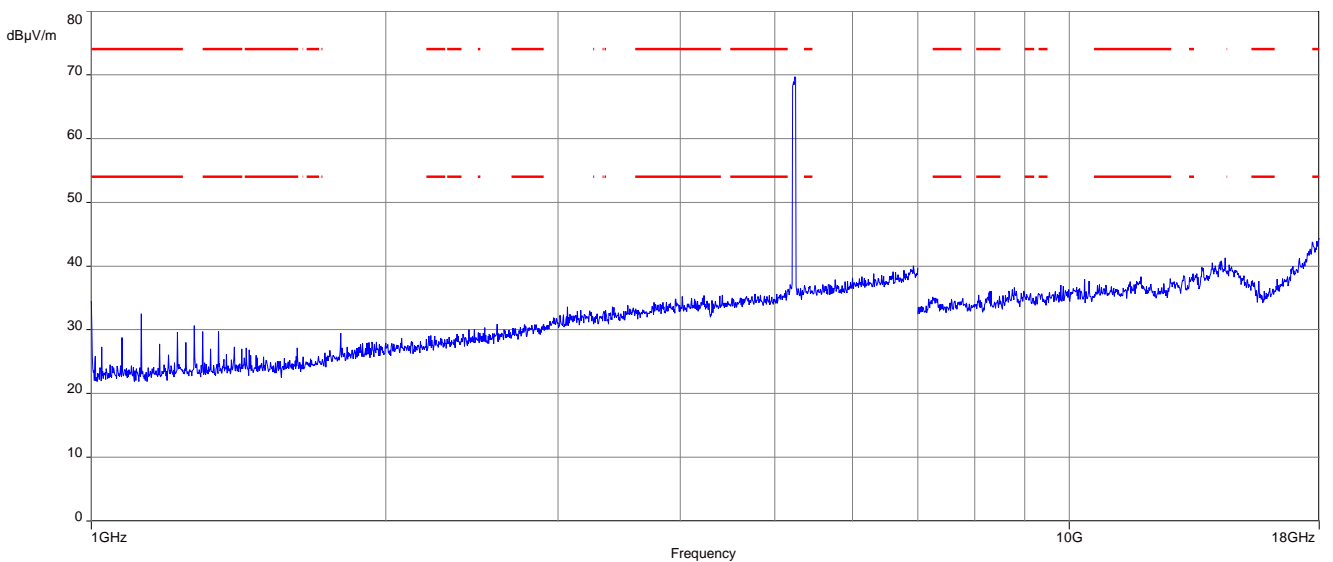

Plot 5: 18 GHz to 26 GHz; vertical & horizontal polarization; U-NII-1; highest channel

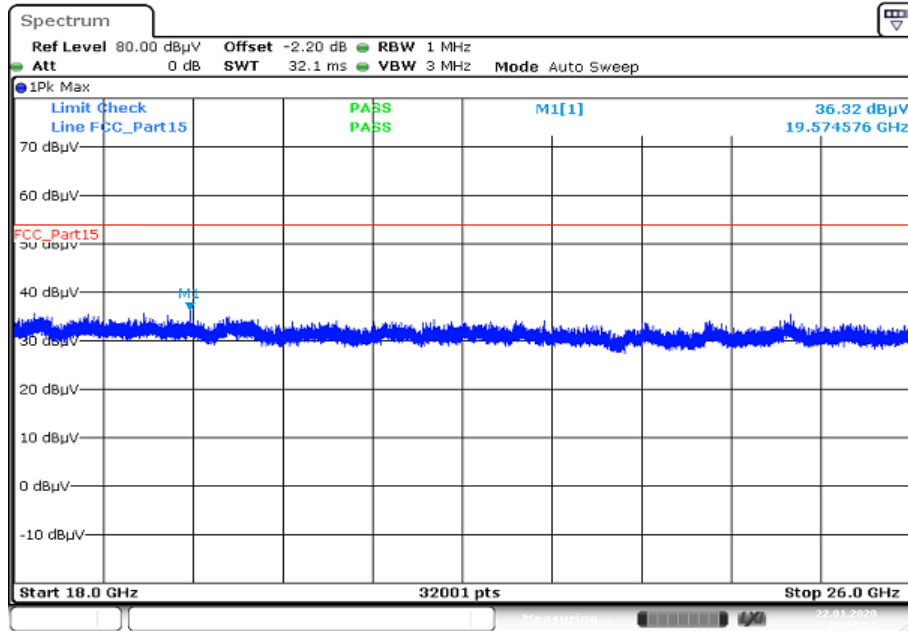

Plot 6: 26 GHz to 40 GHz; vertical & horizontal polarization; U-NII-1; highest channel

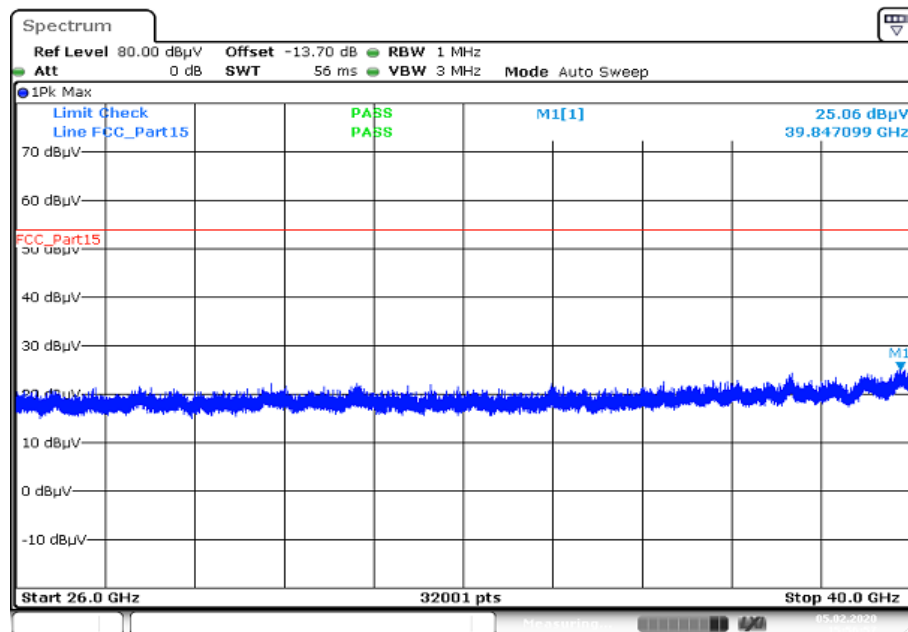

Plot 7: 1 GHz to 18 GHz; vertical & horizontal polarization; U-NII-2A; lowest channel

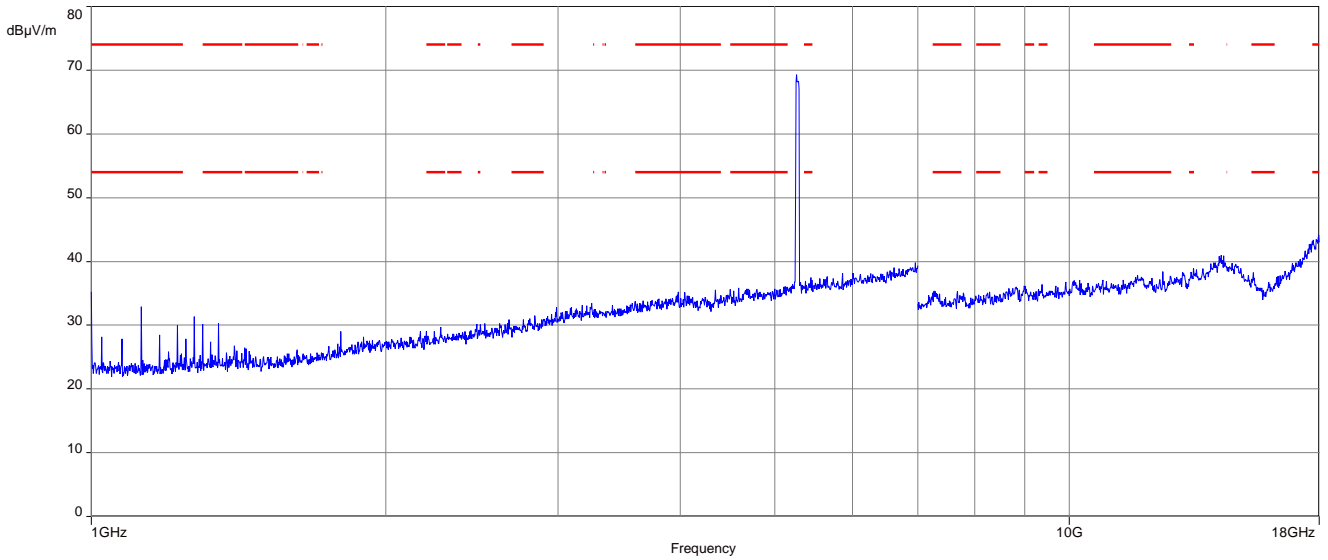

Plot 8: 18 GHz to 26 GHz; vertical & horizontal polarization; U-NII-2A; lowest channel

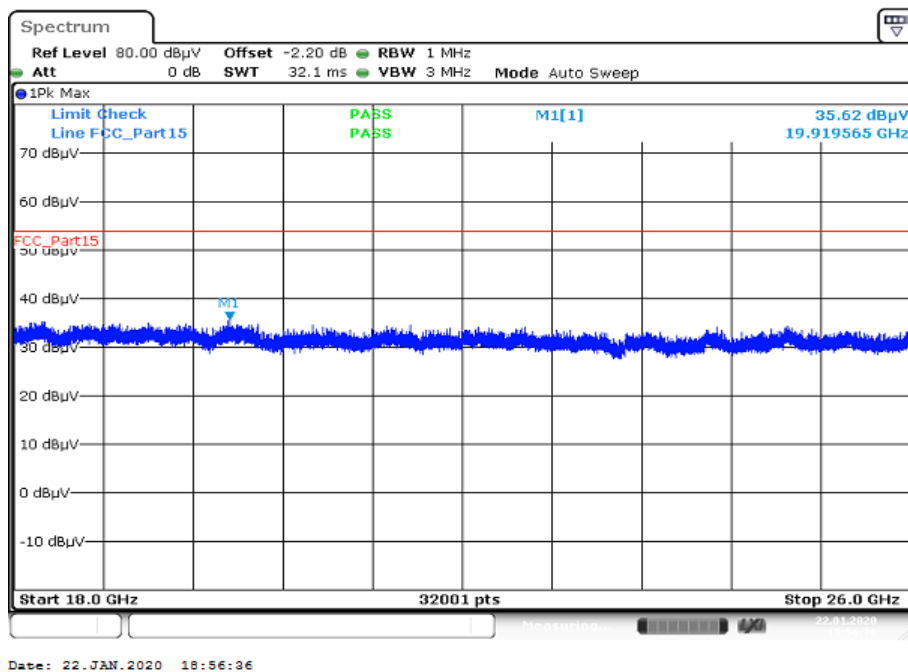

Plot 9: 26 GHz to 40 GHz; vertical & horizontal polarization; U-NII-2A; lowest channel

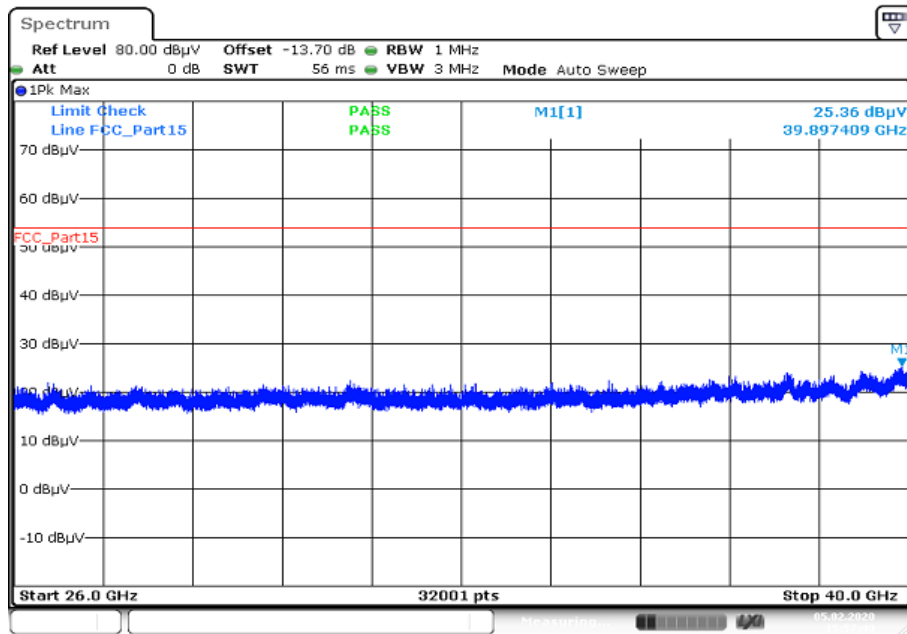

Plot 10: 1 GHz to 18 GHz; vertical & horizontal polarization; U-NII-2A; highest channel

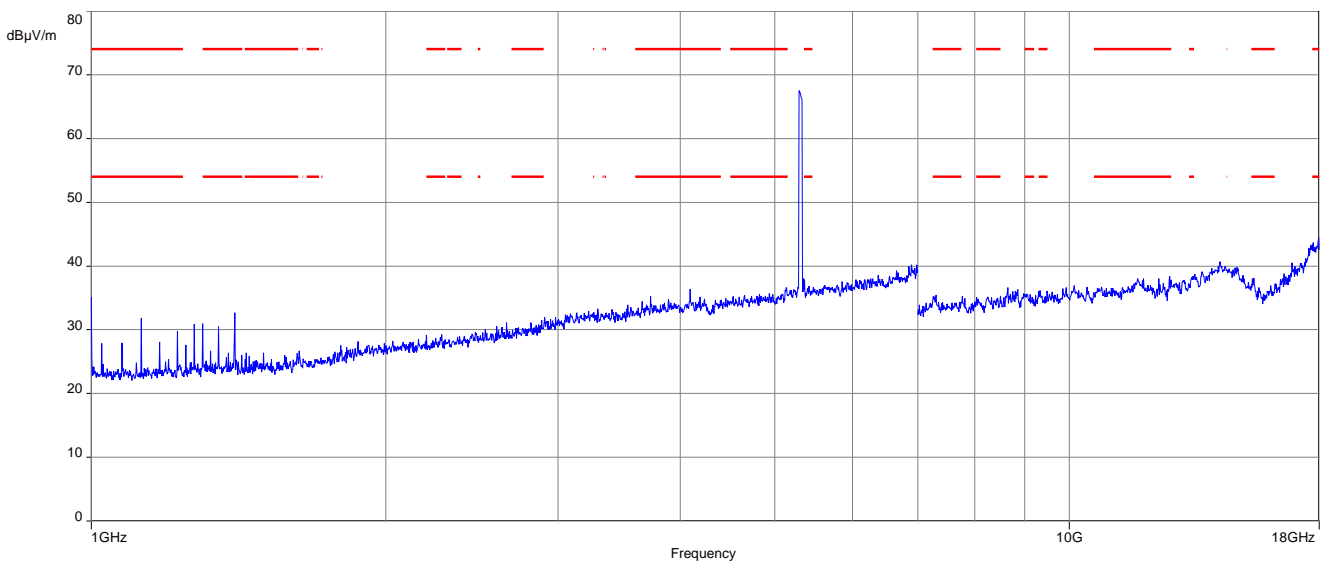

Plot 11: 18 GHz to 26 GHz; vertical & horizontal polarization; U-NII-2A; highest channel

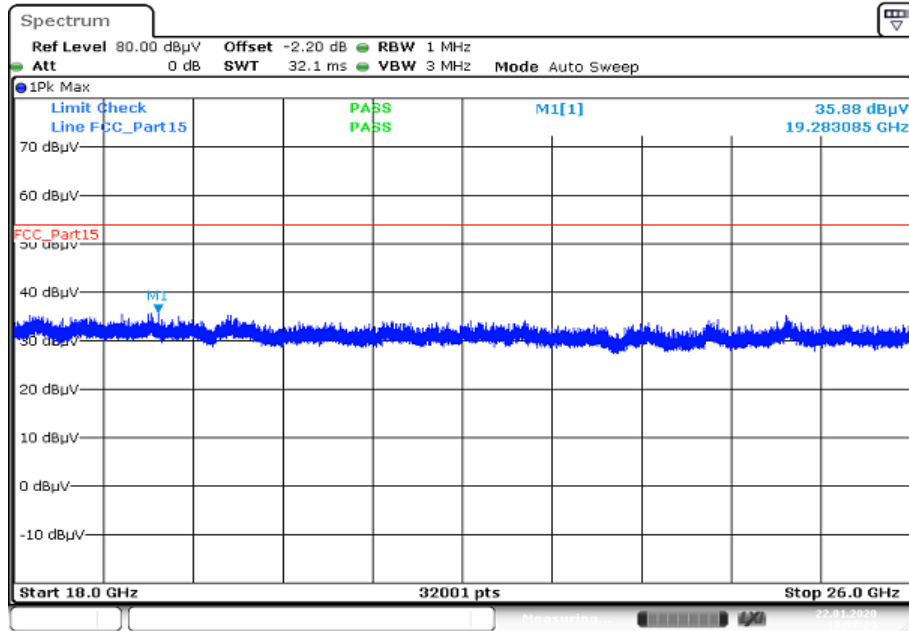

Plot 12: 26 GHz to 40 GHz; vertical & horizontal polarization; U-NII-2A; highest channel

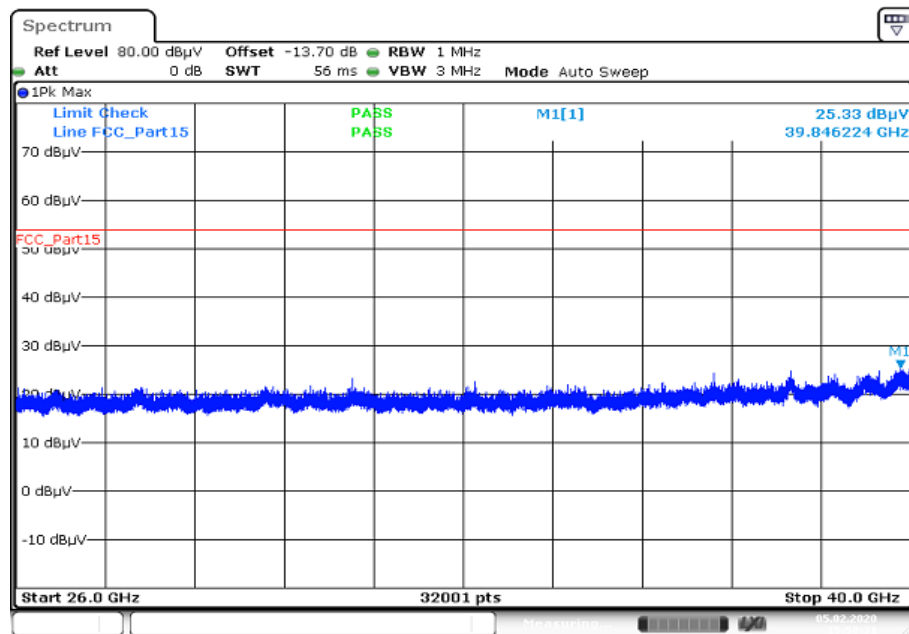

Plot 13: 1 GHz to 18 GHz; vertical & horizontal polarization; U-NII-2C; lowest channel

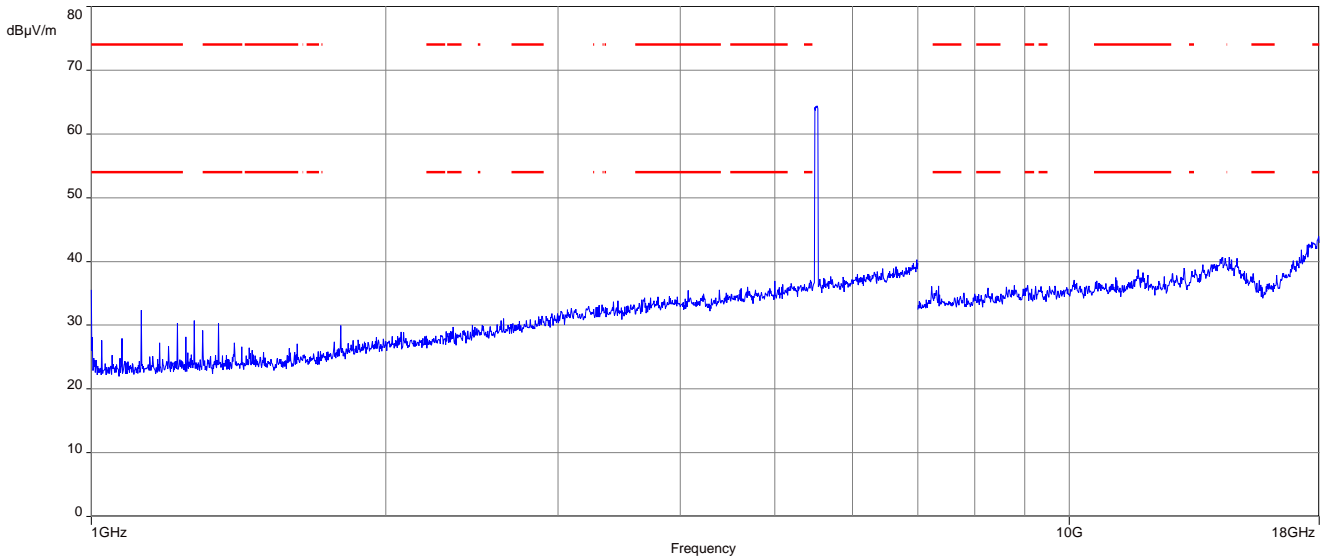

Plot 14: 18 GHz to 26 GHz; vertical & horizontal polarization; U-NII-2C; lowest channel

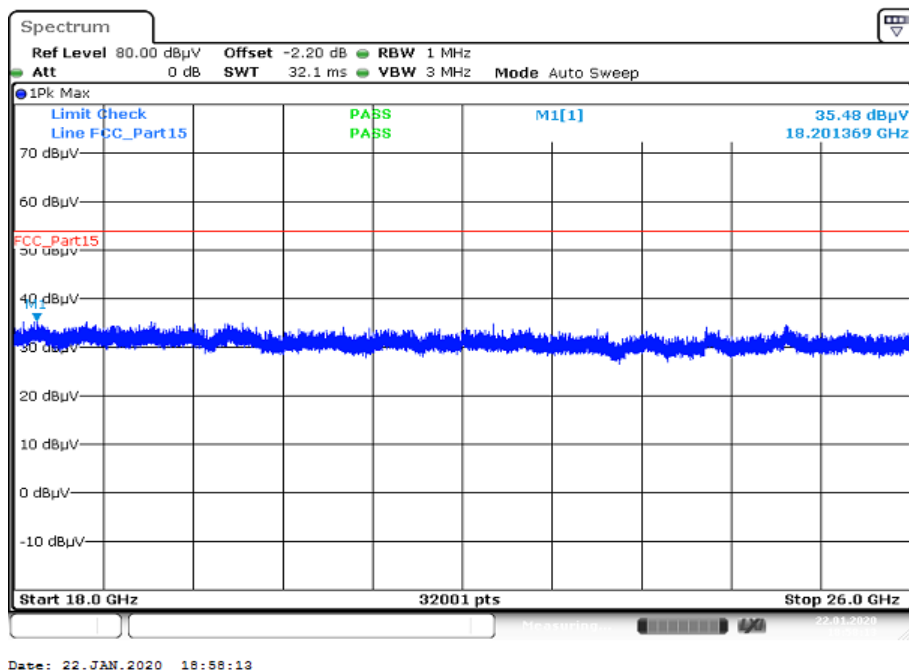

Plot 15: 26 GHz to 40 GHz; vertical & horizontal polarization; U-NII-2C; lowest channel

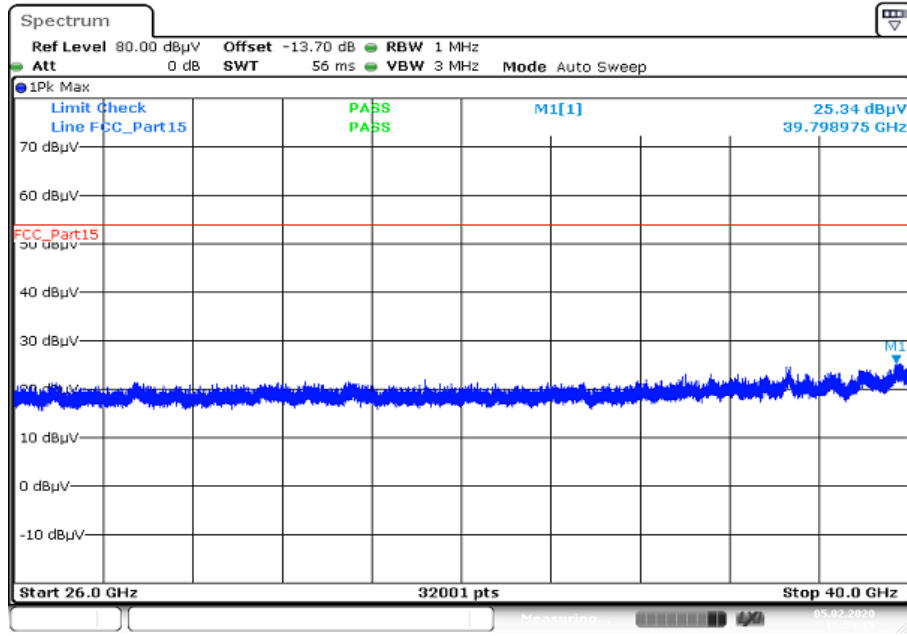

Plot 16: 1 GHz to 18 GHz; vertical & horizontal polarization; U-NII-2C; middle channel

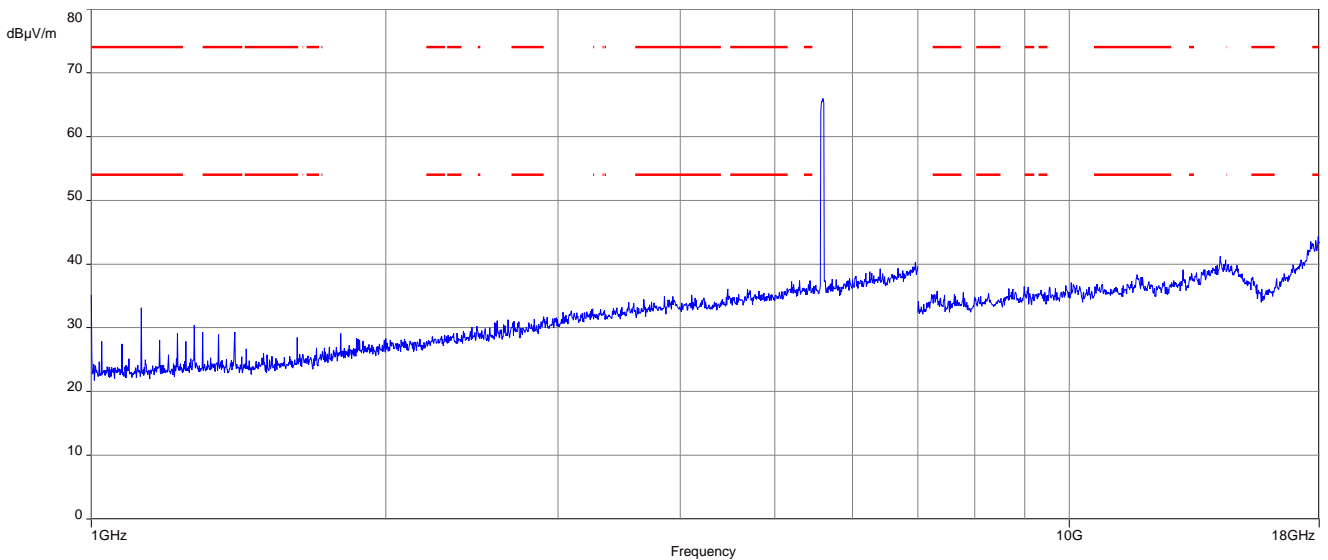

Plot 17: 18 GHz to 26 GHz; vertical & horizontal polarization; U-NII-2C; middle channel

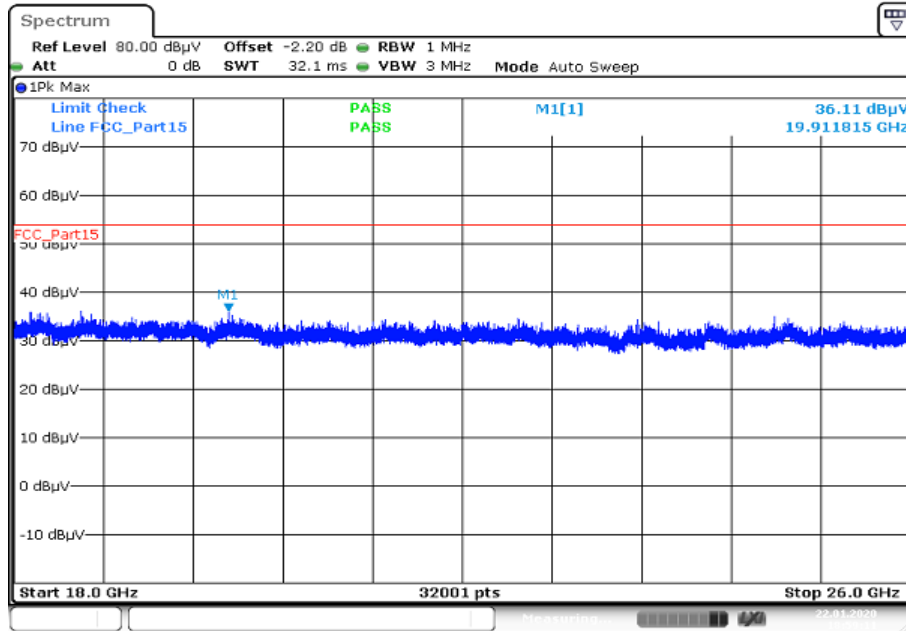

Plot 18: 26 GHz to 40 GHz; vertical & horizontal polarization; U-NII-2C; middle channel

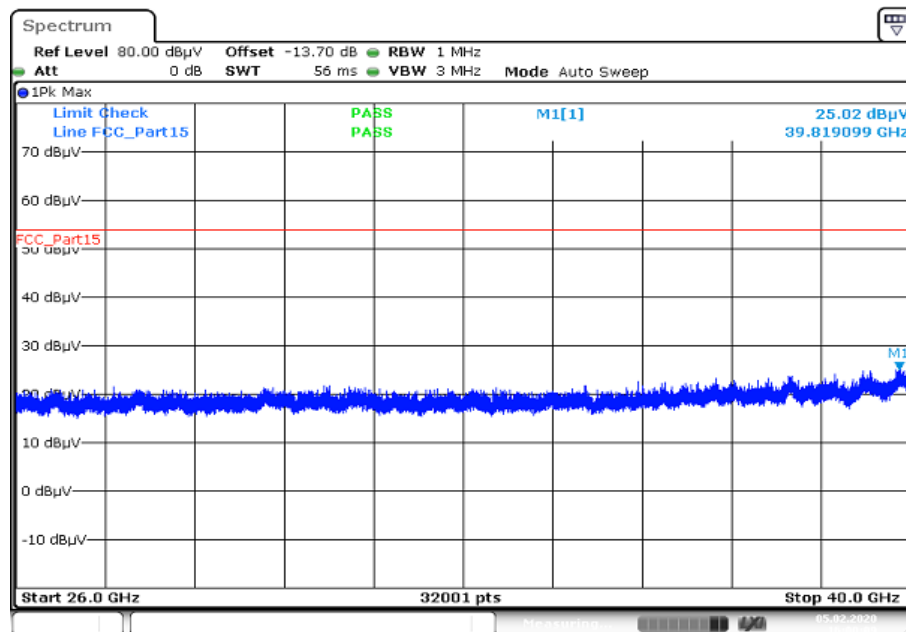

Plot 19: 1 GHz to 18 GHz; vertical & horizontal polarization; U-NII-2C; highest channel

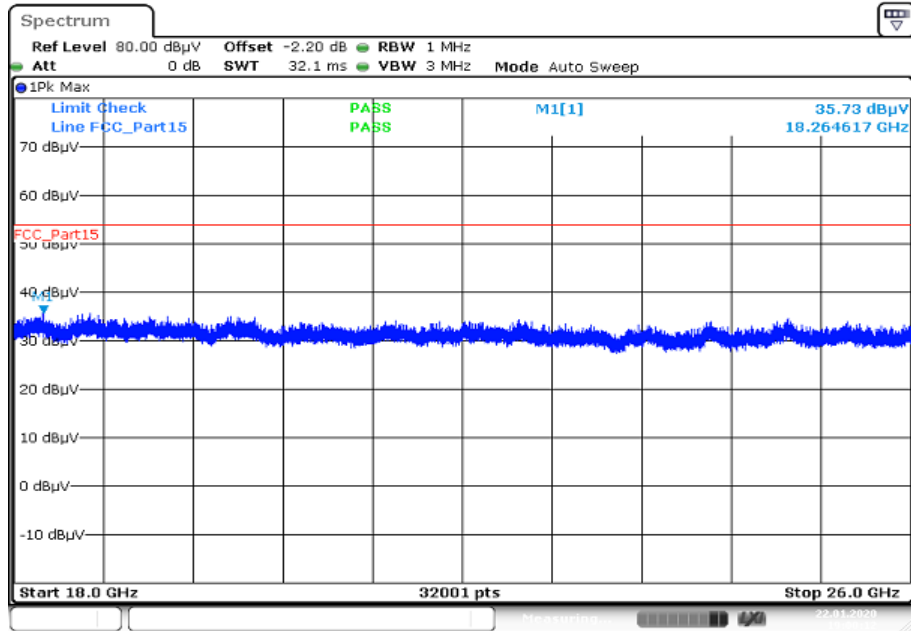

Plot 20: 18 GHz to 26 GHz; vertical & horizontal polarization; U-NII-2C; highest channel

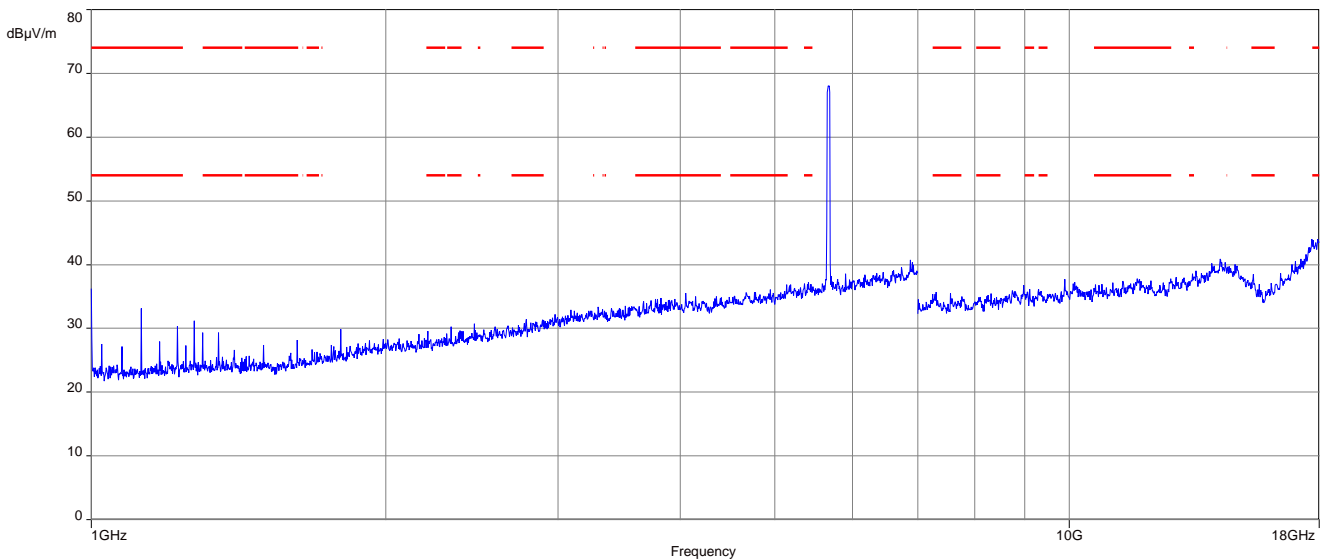

Plot 21: 26 GHz to 40 GHz; vertical & horizontal polarization; U-NII-2C; highest channel

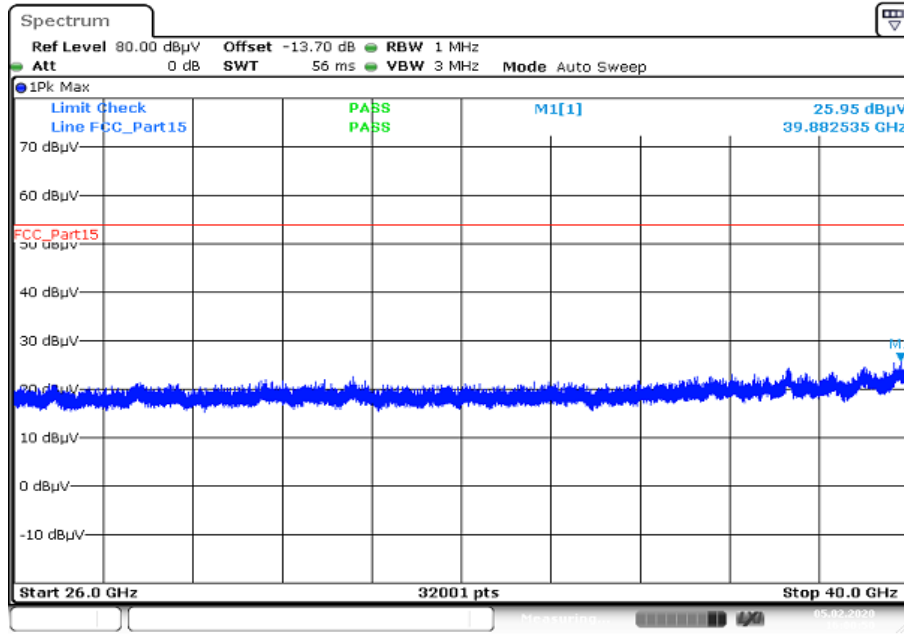

Plot 22: 1 GHz to 18 GHz; vertical & horizontal polarization; U-NII-3; lowest channel

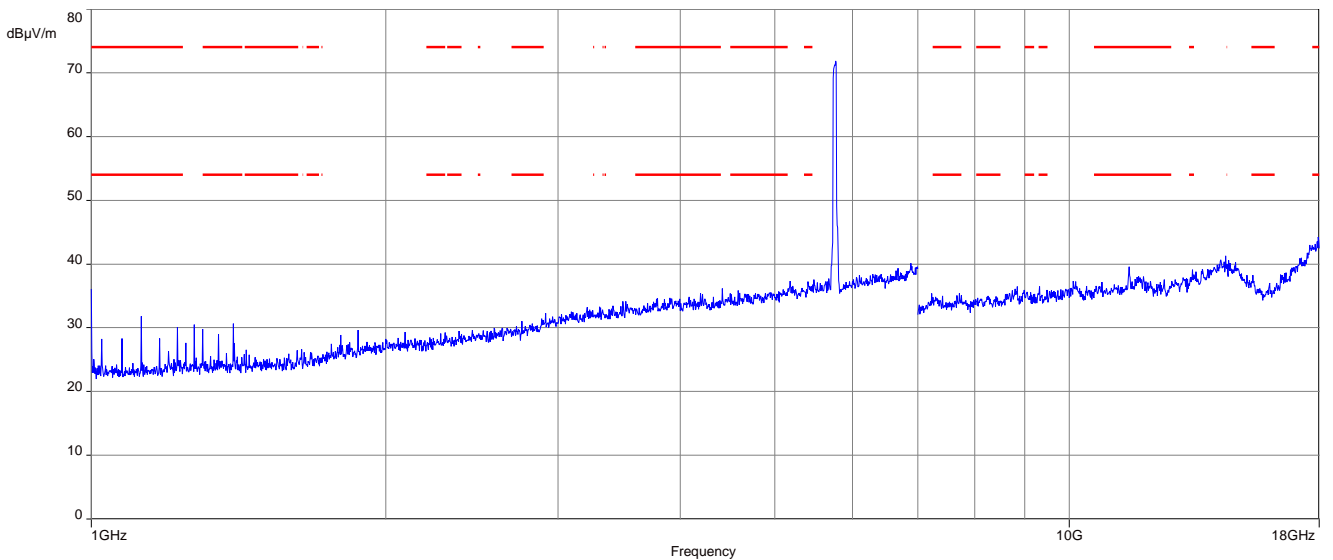

Plot 23: 18 GHz to 26 GHz; vertical & horizontal polarization; U-NII-3; lowest channel

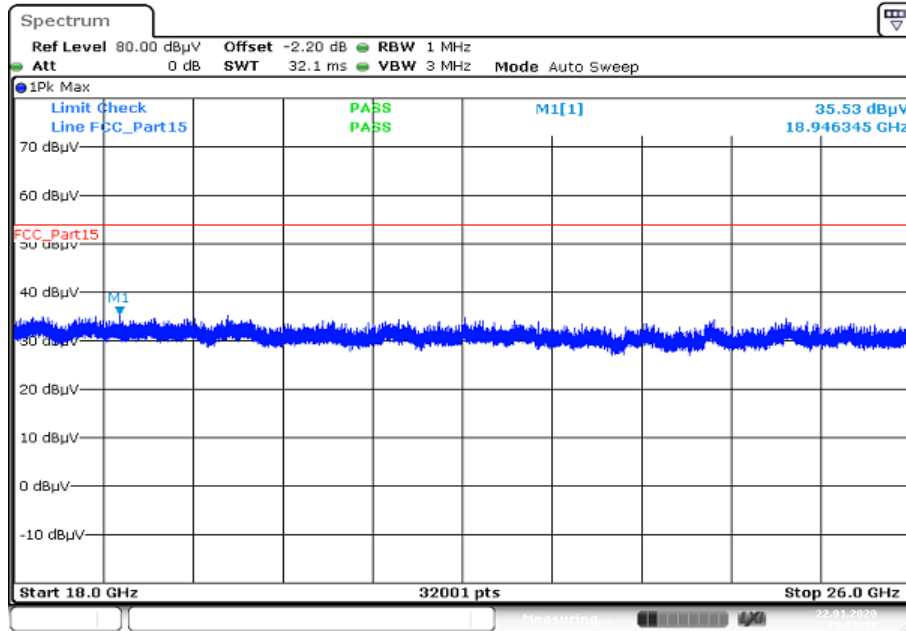

Plot 24: 26 GHz to 40 GHz; vertical & horizontal polarization; U-NII-3; lowest channel

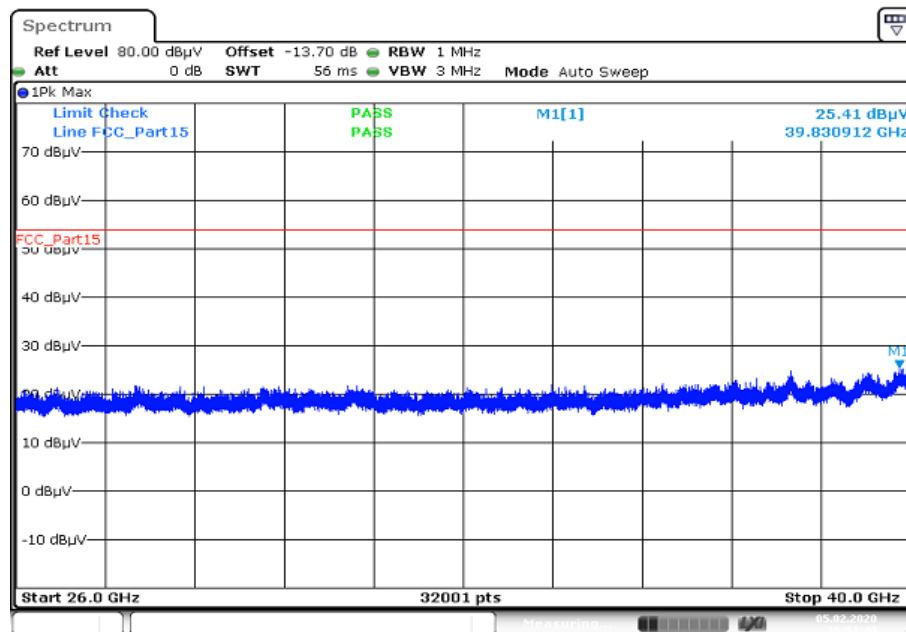

Plot 25: 1 GHz to 18 GHz; vertical & horizontal polarization; U-NII-3; highest channel

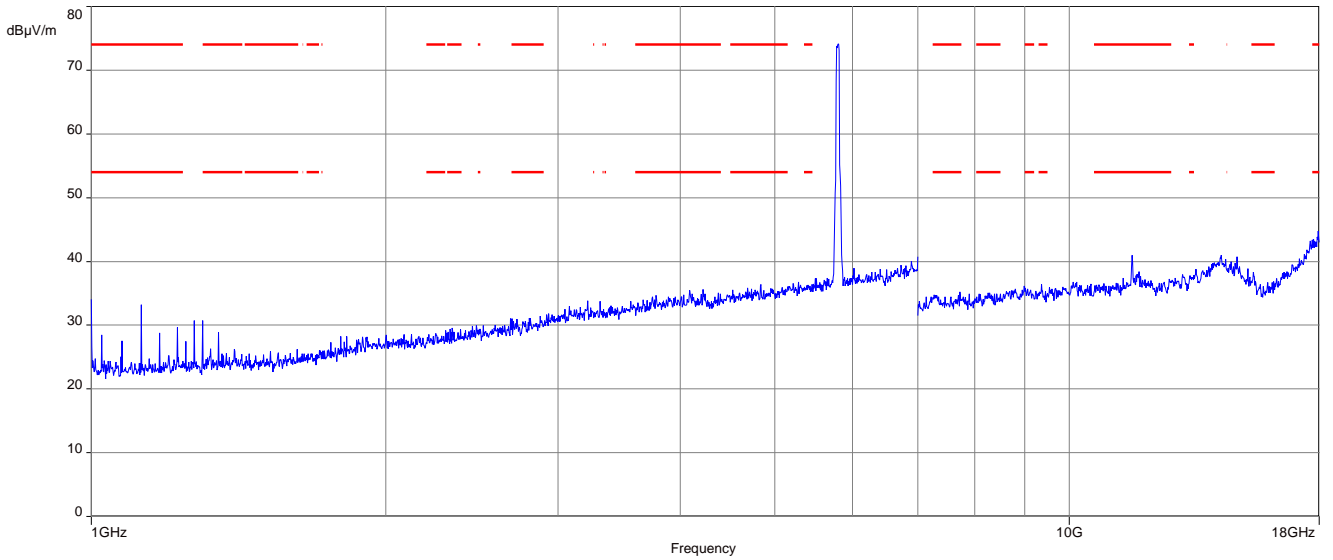

Plot 26: 18 GHz to 26 GHz; vertical & horizontal polarization; U-NII-3; highest channel

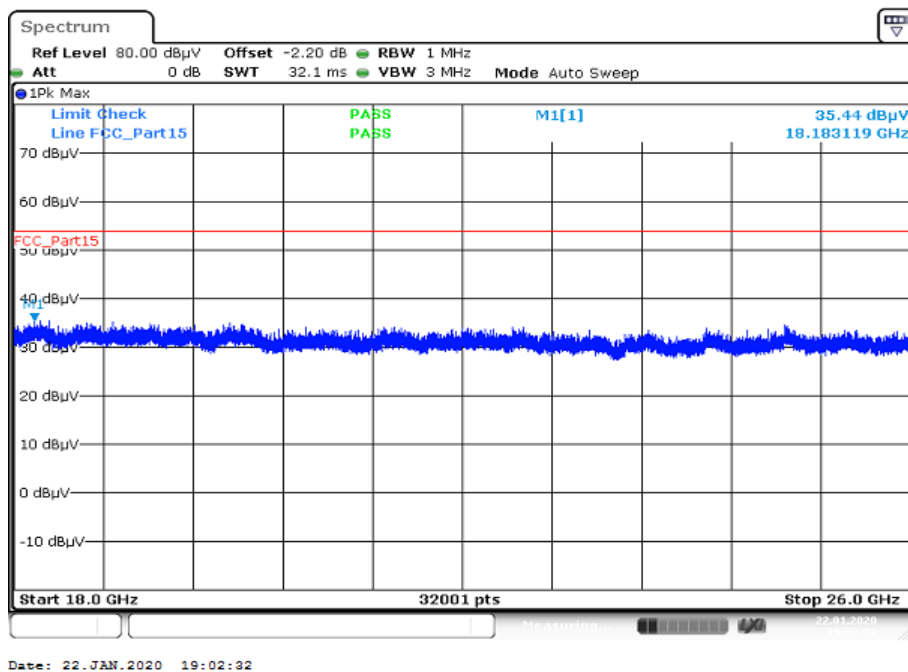

Plot 27: 26 GHz to 40 GHz; vertical & horizontal polarization; U-NII-3; highest channel

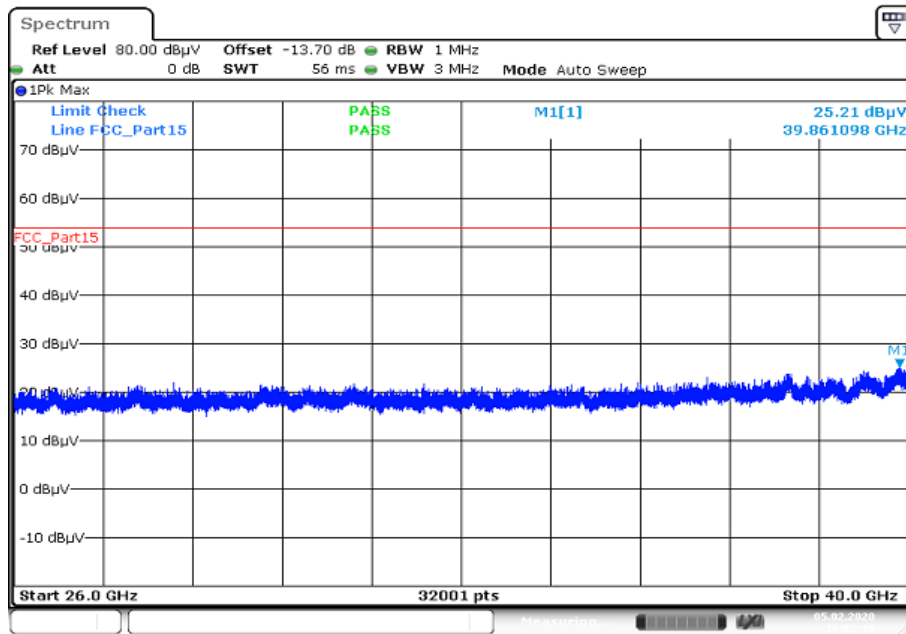

Date: 5.FEB.2020 16:02:18

Plot 31: 1 GHz to 18 GHz, 5825 MHz, vertical & horizontal polarization, cabinet radiation

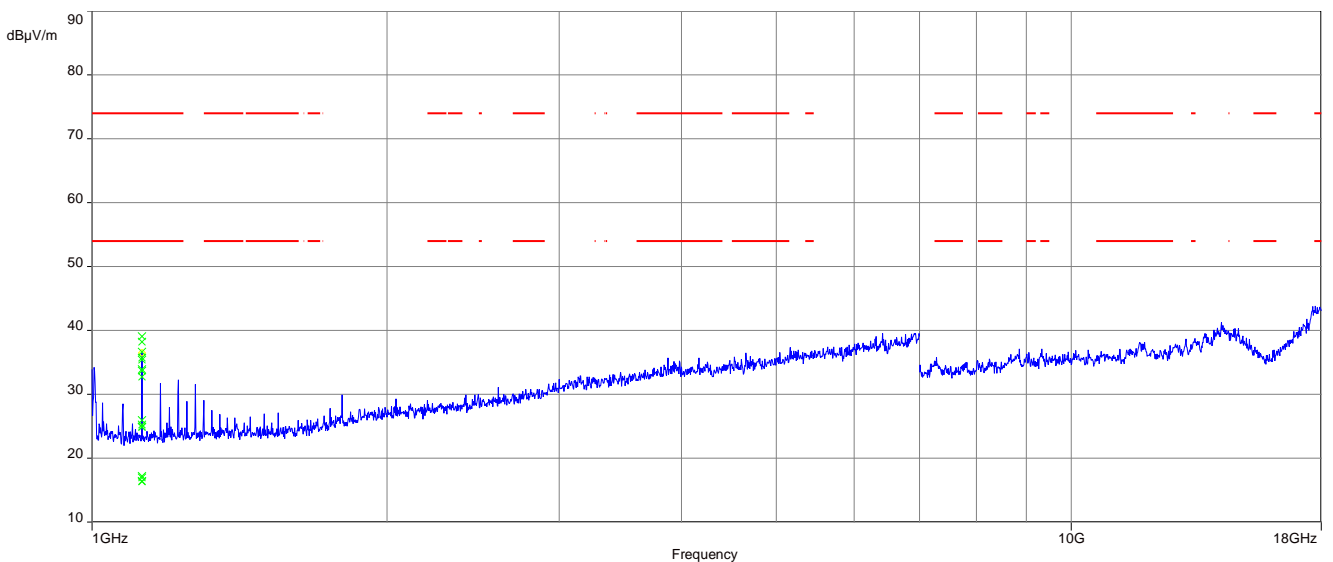

Plot 32: 18 GHz to 26 GHz, 5825 MHz, vertical & horizontal polarization, cabinet radiation

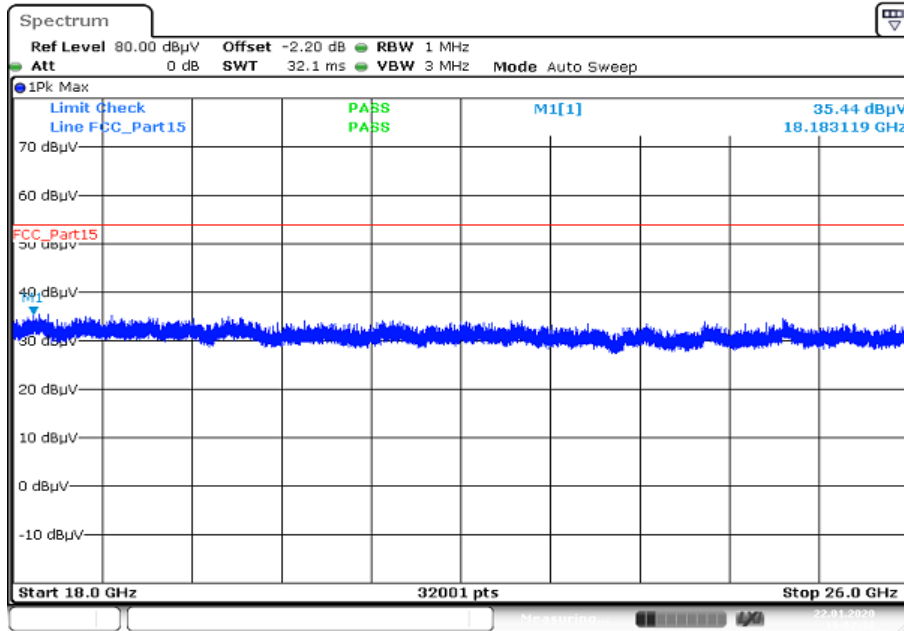

Plot 33: 26 GHz to 40 GHz, 5825 MHz, vertical & horizontal polarization, cabinet radiation

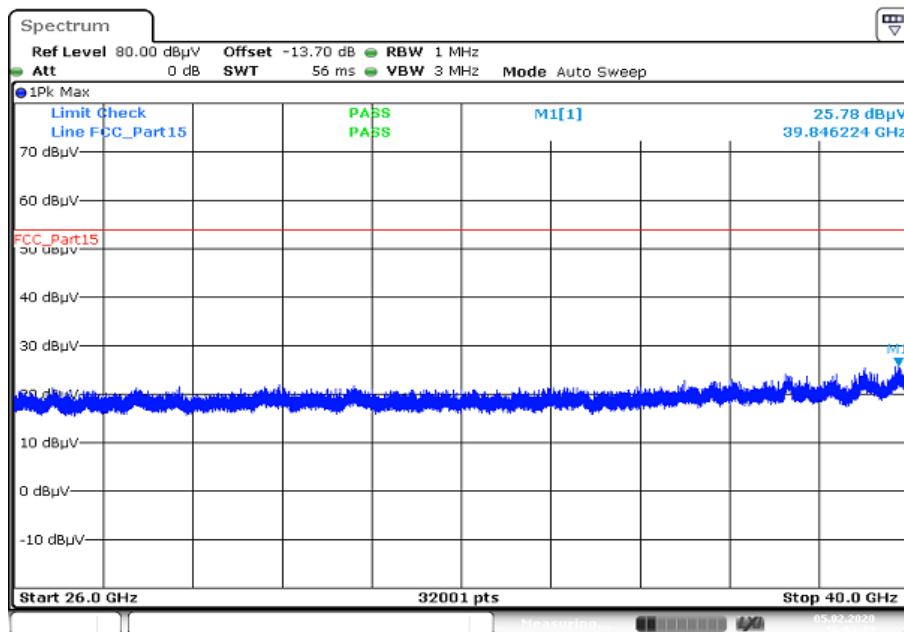

11.13 Spurious emissions conducted below 30 MHz (AC conducted)

Description:

Measurement of the conducted spurious emissions in transmit mode below 30 MHz. Both power lines, phase and neutral line, are measured. Found peaks are re-measured with average and quasi peak detection to show compliance to the limits.

Measurement:

Measurement parameter	
Detector	Peak - Quasi Peak / Average
Sweep time	Auto
Resolution bandwidth	F < 150 kHz: 200 Hz F > 150 kHz: 9 kHz
Video bandwidth	F < 150 kHz: 1 kHz F > 150 kHz: 100 kHz
Span	9 kHz to 30 MHz
Trace mode	Max. hold
Test setup	See chapter 6.4 - A
Measurement uncertainty	See chapter 8

Limits:

FCC		IC
Frequency / MHz)	Quasi-Peak / (dB μ V / m)	Average / (dB μ V / m)
0.15 – 0.5	66 to 56*	56 to 46*
0.5 – 5	56	46
5 – 30.0	60	50

*Decreases with the logarithm of the frequency

Plots:

Plot 1: 150 kHz to 30 MHz, phase line

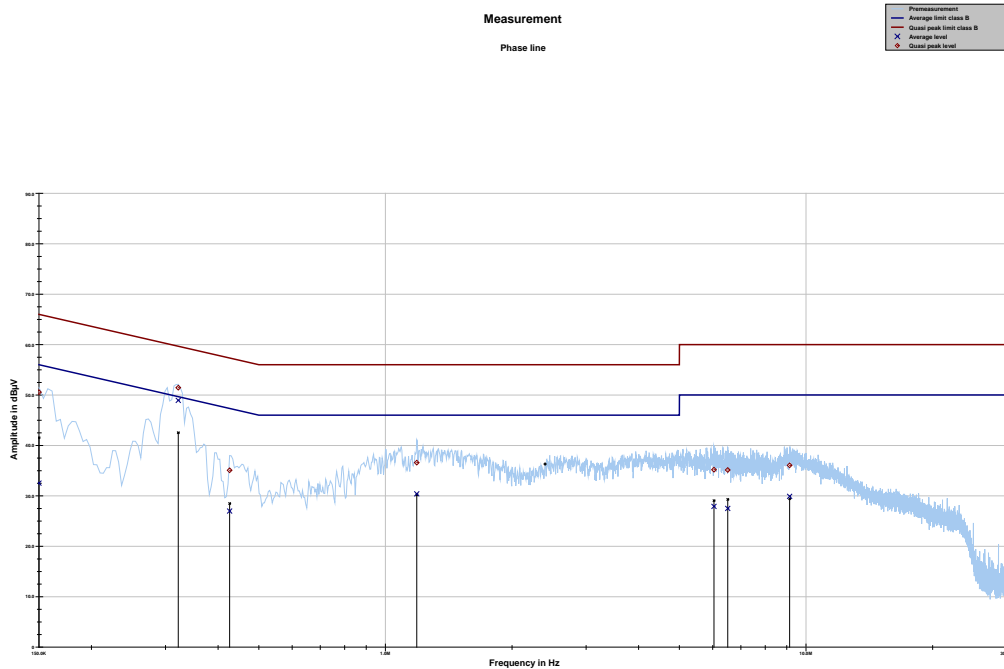

Project ID: 1-9148/19-01-03

Final results:

Frequency	Quasi peak level	Margin quasi peak	Limit QP	Average level	Margin average	Limit AV
MHz	dBµV	dB	dBµV	dBµV	dB	dBµV
0.150000	50.56	15.44	66.000	32.52	23.48	56.000
0.321638	51.44	8.22	59.664	48.93	2.17	51.096
0.426113	35.07	22.26	57.328	26.99	21.12	48.111
1.187288	36.59	19.41	56.000	30.39	15.61	46.000
6.041644	35.19	24.81	60.000	27.91	22.09	50.000
6.515512	35.13	24.87	60.000	27.50	22.50	50.000
9.142312	36.04	23.96	60.000	29.89	20.11	50.000

Plot 2: 150 kHz to 30 MHz, neutral line

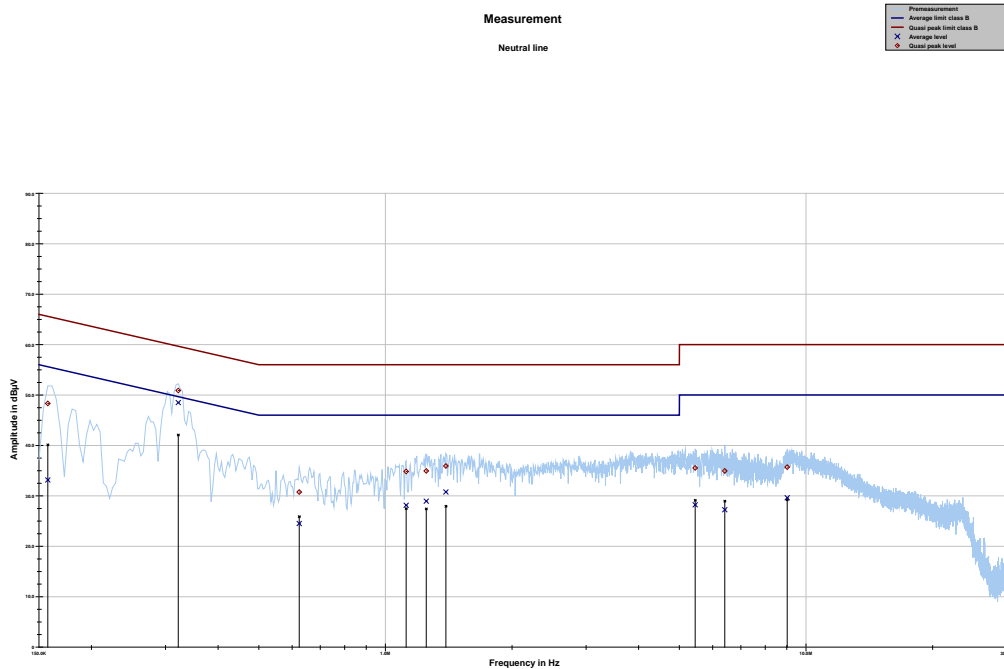

Final results:

Frequency	Quasi peak level	Margin quasi peak	Limit QP	Average level	Margin Average	Limit AV
MHz	dBµV	dB	dBµV	dBµV	dB	dBµV
0.157463	48.32	17.27	65.597	33.15	22.64	55.787
0.321638	50.89	8.77	59.664	48.49	2.61	51.096
0.623869	30.75	25.25	56.000	24.52	21.48	46.000
1.120125	34.82	21.18	56.000	28.13	17.87	46.000
1.250719	34.94	21.06	56.000	28.94	17.06	46.000
1.392506	35.91	20.09	56.000	30.77	15.23	46.000
5.452106	35.53	24.47	60.000	28.21	21.79	50.000
6.411037	34.94	25.06	60.000	27.25	22.75	50.000
9.022913	35.69	24.31	60.000	29.63	20.37	50.000

12 Observations

No observations except those reported with the single test cases have been made.

Annex A Glossary

EUT	Equipment under test
DUT	Device under test
UUT	Unit under test
GUE	GNSS User Equipment
ETSI	European Telecommunications Standards Institute
EN	European Standard
FCC	Federal Communications Commission
FCC ID	Company Identifier at FCC
IC	Industry Canada
PMN	Product marketing name
HMN	Host marketing name
HVIN	Hardware version identification number
FVIN	Firmware version identification number
EMC	Electromagnetic Compatibility
HW	Hardware
SW	Software
Inv. No.	Inventory number
S/N or SN	Serial number
C	Compliant
NC	Not compliant
NA	Not applicable
NP	Not performed
PP	Positive peak
QP	Quasi peak
AVG	Average
OC	Operating channel
OCW	Operating channel bandwidth
OBW	Occupied bandwidth
OOB	Out of band
DFS	Dynamic frequency selection
CAC	Channel availability check
OP	Occupancy period
NOP	Non occupancy period
DC	Duty cycle
PER	Packet error rate
CW	Clean wave
MC	Modulated carrier
WLAN	Wireless local area network
RLAN	Radio local area network
DSSS	Dynamic sequence spread spectrum
OFDM	Orthogonal frequency division multiplexing
FHSS	Frequency hopping spread spectrum
GNSS	Global Navigation Satellite System
C/N₀	Carrier to noise-density ratio, expressed in dB-Hz

Annex B Document history

Version	Applied changes	Date of release
-/-	Initial release	2020-02-19

Annex C Accreditation Certificate – D-PL-12076-01-04

first page	last page
 <p>The first page of the accreditation certificate includes the DAkkS logo (Deutsche Akkreditierungsstelle), the company name Deutsche Akkreditierungsstelle GmbH, and the accreditation details for CTC advanced GmbH. It states that the company is entrusted according to Section 8 subsection 1 of the AkkStelleG in connection with Section 1 subsection 1 of the AkkStelleGBV, signatory to the Multilateral Agreements of EA, ILAC and IAF for Mutual Recognition. The accreditation is for Telecommunication (TC) and Electromagnetic Compatibility (EMC) for Canadian Standards. The certificate is valid until 21.04.2021. The registration number is D-PL-12076-01-04. The certificate was issued in Frankfurt am Main on 11.01.2019 by Dipl.-Ing. Uwe Zimmermann, Head of Division.</p>	 <p>The last page of the accreditation certificate lists the office addresses for Deutsche Akkreditierungsstelle GmbH: Berlin (Spittelmarkt 10), Frankfurt am Main (Europa-Allee 52), and Braunschweig (Bundesallee 100). It includes legal disclaimers regarding the publication of extracts, the scope of accreditation, and the up-to-date state of membership. The up-to-date state of membership can be retrieved from the following websites: EA: www.european-accreditation.org, ILAC: www.ilac.org, IAF: www.iaf.eu.</p>

Note: The current certificate annex is published on the website (link see below) of the Accreditation Body DAkkS or may be received by CTC advanced GmbH on request

<https://www.dakks.de/as/ast/d/D-PL-12076-01-04.pdf>

Annex D Accreditation Certificate – D-PL-12076-01-05

first page	last page			
 <p>Deutsche Akkreditierungsstelle GmbH</p> <p>Entrusted according to Section 8 subsection 1 AkkStelleG in connection with Section 1 subsection 1 AkkStelleGBV Signatory to the Multilateral Agreements of EA, ILAC and IAF for Mutual Recognition</p> <p>Accreditation </p> <p>The Deutsche Akkreditierungsstelle GmbH attests that the testing laboratory CTC advanced GmbH Untertürkheimer Straße 6-10, 66117 Saarbrücken is competent under the terms of DIN EN ISO/IEC 17025:2005 to carry out tests in the following fields: Telecommunication (FCC Requirements)</p> <p>The accreditation certificate shall only apply in connection with the notice of accreditation of 11.01.2019 with the accreditation number D-PL-12076-01 and is valid until 21.04.2021. It comprises the cover sheet, the reverse side of the cover sheet and the following annex with a total of 5 pages.</p> <p>Registration number of the certificate: D-PL-12076-01-05</p> <p>Frankfurt am Main, 11.01.2019  Dipl.-Biol. Uwe Zimmermann Head of Division</p>	<p>Deutsche Akkreditierungsstelle GmbH</p> <table border="0"> <tr> <td>Office Berlin Spittelmarkt 10 10117 Berlin</td> <td>Office Frankfurt am Main Europa-Allee 52 60327 Frankfurt am Main</td> <td>Office Braunschweig Bundesallee 100 38116 Braunschweig</td> </tr> </table> <p>The publication of extracts of the accreditation certificate is subject to the prior written approval by Deutsche Akkreditierungsstelle GmbH (DAkks). Exempted is the unchanged form of separate disseminations of the cover sheet by the conformity assessment body mentioned overleaf.</p> <p>No impression shall be made that the accreditation also extends to fields beyond the scope of accreditation attested by DAkks.</p> <p>The accreditation was granted pursuant to the Act on the Accreditation Body (AkkStelleG) of 31 July 2009 (Federal Law Gazette I p. 2625) and the Regulation (EC) No 765/2008 of the European Parliament and of the Council of 9 July 2008 setting out the requirements for accreditation and market surveillance relating to the marketing of products (Official Journal of the European Union L 218 of 9 July 2008, p. 30). DAkks is a signatory to the Multilateral Agreements for Mutual Recognition of the European co-operation for Accreditation (EA), International Accreditation Forum (IAF) and International Laboratory Accreditation Cooperation (ILAC). The signatories to these agreements recognise each other's accreditations.</p> <p>The up-to-date state of membership can be retrieved from the following websites: EA: www.european-accreditation.org ILAC: www.ilac.org IAF: www.iaf.eu</p>	Office Berlin Spittelmarkt 10 10117 Berlin	Office Frankfurt am Main Europa-Allee 52 60327 Frankfurt am Main	Office Braunschweig Bundesallee 100 38116 Braunschweig
Office Berlin Spittelmarkt 10 10117 Berlin	Office Frankfurt am Main Europa-Allee 52 60327 Frankfurt am Main	Office Braunschweig Bundesallee 100 38116 Braunschweig		

Note: The current certificate annex is published on the website (link see below) of the Accreditation Body DAkks or may be received by CTC advanced GmbH on request

<https://www.dakks.de/as/ast/d/D-PL-12076-01-05.pdf>

END OF TEST REPORT