



FCC PART 15.407  
DYNAMIC FREQUENCY SELECTION  
TEST REPORT

For

**INGENICO**

9 Avenue de la Gare-Rolvatain TGV, BP 25156, Valence Cedex 9,France

**FCC ID: XKB-L2500CLWIBT**

<b>Report Type:</b> Original Report	<b>Product Name:</b> Link/2500
<b>Test Engineer:</b> <u>Edison Hu</u>	<i>Edison.hu</i>
<b>Report Number:</b> <u>RXM170217051-00</u>	
<b>Report Date:</b> <u>2017-03-22</u>	
<b>Reviewed By:</b> <u>Oscar Ye Engineer</u>	<i>Oscar.Ye</i>
<b>Test Laboratory:</b> Bay Area Compliance Laboratories Corp. (Kunshan) No.248 Chenghu Road,Kunshan, Jiangsu province,China Tel: +86-0512-86175000 Fax: +86-0512-88934268 <a href="http://www.baclcorp.com.cn">www.baclcorp.com.cn</a>	

**Note:** This test report is prepared for the customer shown above and for the device described herein. It may not be duplicated or used in part without prior written consent from Bay Area Compliance Laboratories Corp. (Kunshan). This report is valid only with a valid digital signature. The digital signature may be available only under the Adobe software above version 7.0.

## TABLE OF CONTENTS

<b>GENERAL INFORMATION</b> .....	<b>3</b>
PRODUCT DESCRIPTION FOR EQUIPMENT UNDER TEST (EUT) .....	3
OBJECTIVE .....	3
RELATED SUBMITTAL(S)/GRANT(S).....	3
TEST METHODOLOGY .....	3
TEST FACILITY .....	4
<b>SUMMARY OF TEST RESULTS</b> .....	<b>5</b>
<b>BELOW IS THE ATTACHMENT</b> .....	<b>6</b>

---

## GENERAL INFORMATION

---

### Product Description for Equipment under Test (EUT)

The INGENICO's product, model number: Link/2500 CL/WiFi/BT (FCC ID: XKB-L2500CLWIBT) (or "EUT") in this report is a *Link/2500*, which was measured approximately: 129 cm (L) x 70 mm (W) x 17 mm (H), rated input voltage: DC 3.7V from rechargeable Li-ion battery or DC 5V from adapter. The device is a client device.

Adapter information:

MODEL: PSAI05R-050QL6

INPUT: 100-240V ~ 0.3A 50-60Hz 11-15VA

OUTPUT: DC 5V, 1.0A MAX.

*\*All measurement and test data in this report was gathered from production sample serial number: 170217051 (Assigned by the BACL). The EUT supplied by the applicant was received on 2017-02-17.*

### Objective

This report is prepared on behalf of *INGENICO* in accordance with Part 2-Subpart J, Part 15-Subparts A and E of the Federal Communications Commission's rules.

The tests were performed in order to determine compliance with FCC Rules Part 15, Subpart E, section 15.203, 15.205, 15.207, 15.209 and 15.407 rules.

This device has the same PCB layout with another device with FCC ID: XKB-L2500CL3GWIBT. The difference between them is depressing WWAN (2G/3G) function and replacing SIM to SAM function.

The change made to the device will not affect all the test results of Dynamic Frequency Selection, so all the test results please refer to the Model: LINK/2500 CL/3G/WiFi/BT's report RXM161124051-00A1 that was issued on 2017-03-21.

### Related Submittal(s)/Grant(s)

FCC Part 15.225 DXX submissions with FCC ID: XKB-L2500CLWIBT.

FCC Part 15C DSS submissions with FCC ID: XKB-L2500CLWIBT.

FCC Part 15C DTS submissions with FCC ID: XKB-L2500CLWIBT.

FCC Part 15.407 NII submissions with FCC ID: XKB-L2500CLWIBT.

### Test Methodology

FCC KDB 905462 D02 UNII DFS Compliance Procedures New Rules v02.

FCC KDB 905462 D03 Client without DFS New Rules v01r02.

## **Test Facility**

The test site used by Bay Area Compliance Laboratories Corp. (Kunshan) to collect test data is located on No.248 Chenghu Road, Kunshan, Jiangsu province, China.

Test site at Bay Area Compliance Laboratories Corp. (Kunshan) has been fully described in reports submitted to the Federal Communication Commission (FCC). The details of these reports have been found to be in compliance with the requirements of Section 2.948 of the FCC Rules on November 06, 2014. The facility also complies with the radiated and AC line conducted test site criteria set forth in ANSI C63.4-2014.

The Federal Communications Commission has the reports on file and is listed under FCC Registration No.: 815570. The test site has been approved by the FCC for public use and is listed in the FCC Public Access Link (PAL) database.

## SUMMARY OF TEST RESULTS

The following result table represents the list of measurements required under the CFR §47 Part 15.407(h), and KDB: 905462 D02 UNII DFS Compliance Procedures New Rules v02 and KDB 905462 D03 Client Without DFS New Rules v01r02

Items	Description of Test	Result
Detection Bandwidth	UNII Detection Bandwidth	Not Applicable
Performance Requirements Check	Initial Channel Availability Check Time (CAC)	Not Applicable
	Radar Burst at the Beginning of the CAC	Not Applicable
	Radar Burst at the End of the CAC	Not Applicable
In-Service Monitoring	Channel Move Time	Compliant*
	Channel Closing Transmission Time	Compliant*
	Non-Occupancy Period	Compliant*
Radar Detection	Statistical Performance Check	Not Applicable

Compliant\*: Please refer to the Model: LINK/2500 CL/3G/WiFi/BT's report: RXM161124051-00A1.

**BELOW IS THE ATTACHMENT**

---



FCC PART 15.407  
DYNAMIC FREQUENCY SELECTION  
TEST REPORT

For

**INGENICO**

9 Avenue de la Gare-Rolvatain TGV, BP 25156, Valence Cedex 9, France

**FCC ID: XKB-L2500CL3GWIBT**

<b>Report Type:</b> Class II permissive change	<b>Product Name:</b> Link/2500
<b>Test Engineer:</b> <u>Edison Hu</u>	<i>Edison.hu</i>
<b>Report Number:</b> <u>RXM161124051-00A1</u>	
<b>Report Date:</b> <u>2017-03-21</u>	
<b>Reviewed By:</b> <u>Oscar Ye Engineer</u>	<i>Oscar.Ye</i>
<b>Test Laboratory:</b> Bay Area Compliance Laboratories Corp. (Kunshan) No.248 Chenghu Road, Kunshan, Jiangsu province, China Tel: +86-0512-86175000 Fax: +86-0512-88934268 <a href="http://www.baclcorp.com.cn">www.baclcorp.com.cn</a>	

**Note:** This test report is prepared for the customer shown above and for the device described herein. It may not be duplicated or used in part without prior written consent from Bay Area Compliance Laboratories Corp. (Kunshan). This report is valid only with a valid digital signature. The digital signature may be available only under the Adobe software above version 7.0.

## TABLE OF CONTENTS

<b>GENERAL INFORMATION.....</b>	<b>3</b>
PRODUCT DESCRIPTION FOR EQUIPMENT UNDER TEST (EUT) .....	3
OBJECTIVE .....	3
RELATED SUBMITTAL(S)/GRANT(S).....	3
TEST METHODOLOGY .....	3
TEST FACILITY .....	4
<b>SYSTEM TEST CONFIGURATION.....</b>	<b>5</b>
DESCRIPTION OF TEST CONFIGURATION .....	5
EUT EXERCISE SOFTWARE .....	5
EQUIPMENT MODIFICATIONS .....	5
SUPPORT EQUIPMENT LIST AND DETAILS .....	5
EXTERNAL CABLE.....	5
<b>SUMMARY OF TEST RESULTS .....</b>	<b>6</b>
<b>APPLICABLE STANDARDS.....</b>	<b>7</b>
DFS REQUIREMENT .....	7
DFS MEASUREMENT SYSTEM.....	11
SYSTEM BLOCK DIAGRAM.....	11
CONDUCTED METHOD .....	12
RADIATED METHOD.....	13
TEST PROCEDURE .....	13
<b>TEST RESULTS.....</b>	<b>14</b>
DESCRIPTION OF EUT .....	14
TEST EQUIPMENT LIST AND DETAILS.....	14
RADAR WAVEFORM CALIBRATION .....	15
TEST ENVIRONMENTAL CONDITIONS .....	15
<b>CHANNEL MOVE TIME AND CHANNEL CLOSING TRANSMISSION TIME .....</b>	<b>17</b>
TEST PROCEDURE .....	17
TEST RESULTS .....	17



## GENERAL INFORMATION

### Product Description for Equipment under Test (EUT)

The *INGENICO*'s product, model number: *LINK/2500 CL/3G/WiFi/BT (FCC ID: XKB-L2500C L3GWIBT)* (or "EUT") in this report is a *Link/2500*, which was measured approximately: 12.8 cm (L) x 7.0 cm (W) x 1.7cm (H), rated input voltage: DC 3.7V from rechargeable Li-ion battery or DC 5V from adapter. The device is a client device.

Adapter information:

MODEL: PSA105R-050QL6

INPUT: 100-240V ~ 0.3A 50-60Hz 11-15VA

OUTPUT: DC 5V, 1.0A MAX

*\*All measurement and test data in this report was gathered from production sample serial number: 20161124051. (Assigned by the BACL. The EUT supplied by the applicant was received on 2016-11-25)*

### Objective

This report is prepared on behalf of *INGENICO* in accordance with Part 2-Subpart J, Part 15-Subparts A, B and E of the Federal Communications Commission's rules.

The tests were performed in order to determine compliance with FCC Part 15.407 rules.

This is the Class II Permissive Change application of the device. The difference between the original device and the current one is as follows:

1. Add the frequency band: 5250~5350 MHz, 5470~5725 MHz.

The change made to the device affected all the test results, so we updated all test datas, EUT photos were copied from the report number RXM160823052-00F with FCC ID: XKB-L2500CL3GWIBT.

### Related Submittal(s)/Grant(s)

Original submission with FCC ID: XKB-L2500CL3GWIBT which was granted on 2016-10-04.

### Test Methodology

FCC KDB 905462 D02 UNII DFS Compliance Procedures New Rules v02

FCC KDB 905462 D03 Client Without DFS New Rules v01r02

### **Test Facility**

The test site used by Bay Area Compliance Laboratories Corp. (Kunshan) to collect test data is located on No.248 Chenghu Road, Kunshan, Jiangsu province, China.

Test site at Bay Area Compliance Laboratories Corp. (Kunshan) has been fully described in reports submitted to the Federal Communication Commission (FCC). The details of these reports have been found to be in compliance with the requirements of Section 2.948 of the FCC Rules on November 06, 2014. The facility also complies with the radiated and AC line conducted test site criteria set forth in ANSI C63.4-2014.

The Federal Communications Commission has the reports on file and is listed under FCC Registration No.: 815570. The test site has been approved by the FCC for public use and is listed in the FCC Public Access Link (PAL) database.

FEMVA

## SYSTEM TEST CONFIGURATION

### Description of Test Configuration

The EUT was configured for testing in an engineering mode which was provided by the manufacturer.

### EUT Exercise Software

No software was used in test.

### Equipment Modifications

N/A

### Support Equipment List and Details

Manufacturer	Description	Model	Serial Number
Huawei	Wireless Router	EchoLife HG8245Q	/
Dell	Laptop	E6410	/

Note: the Wireless Router FCC ID: **QISHG8245Q**

### External Cable

Cable Description	Shielding Type	Ferrite Core	Length (m)	From Port	To
RJ45 Cable	No	No	1.5	Router	Laptop

## SUMMARY OF TEST RESULTS

The following result table represents the list of measurements required under the CFR §47 Part 15.407(h), and KDB: 905462 D02 UNII DFS Compliance Procedures New Rules v02 and KDB 905462 D03 Client Without DFS New Rules v01r02

Items	Description of Test	Result
Detection Bandwidth	UNII Detection Bandwidth	Not Applicable
Performance Requirements Check	Initial Channel Availability Check Time (CAC)	Not Applicable
	Radar Burst at the Beginning of the CAC	Not Applicable
	Radar Burst at the End of the CAC	Not Applicable
In-Service Monitoring	Channel Move Time	Compliant
	Channel Closing Transmission Time	Compliant
	Non-Occupancy Period	Compliant
Radar Detection	Statistical Performance Check	Not Applicable

**APPLICABLE STANDARDS**

**DFS Requirement**

CFR §47 Part 15.407(h)

FCC KDB 905462 D02 UNII DFS Compliance Procedures New Rules v02

**Table 1: Applicability of DFS Requirements Prior to Use of a Channel**

Requirement	Operational Mode		
	Master	Client Without Radar Detection	Client With Radar Detection
<i>Non-Occupancy Period</i>	Yes	Not required	Yes
<i>DFS Detection Threshold</i>	Yes	Not required	Yes
<i>Channel Availability Check Time</i>	Yes	Not required	Not required
<i>U-NII Detection Bandwidth</i>	Yes	Not required	Yes

**Table 2: Applicability of DFS requirements during normal operation**

Requirement	Operational Mode	
	Master Device or Client with Radar Detection	Client Without Radar Detection
<i>DFS Detection Threshold</i>	Yes	Not required
<i>Channel Closing Transmission Time</i>	Yes	Yes
<i>Channel Move Time</i>	Yes	Yes
<i>U-NII Detection Bandwidth</i>	Yes	Not required

Additional requirements for devices with multiple bandwidth modes	Master Device or Client with Radar Detection	Client Without Radar Detection
<i>U-NII Detection Bandwidth and Statistical Performance Check</i>	All BW modes must be tested	Not required
<i>Channel Move Time and Channel Closing Transmission Time</i>	Test using widest BW mode available	Test using the widest BW mode available for the link
<i>All other tests</i>	Any single BW mode	Not required
<b>Note:</b> Frequencies selected for statistical performance check (Section 7.8.4) should include several frequencies within the radar detection bandwidth and frequencies near the edge of the radar detection bandwidth. For 802.11 devices it is suggested to select frequencies in each of the bonded 20 MHz channels and the channel center frequency.		

**Table 3: DFS Detection Thresholds for Master Devices and Client Devices With Radar Detection**

Maximum Transmit Power	Value (See Notes 1, 2, and 3)
EIRP ≥ 200 milliwatt	-64 dBm
EIRP < 200 milliwatt and power spectral density < 10 dBm/MHz	-62 dBm
EIRP < 200 milliwatt that do not meet the power spectral density requirement	-64 dBm
<p><b>Note 1:</b> This is the level at the input of the receiver assuming a 0 dBi receive antenna.</p> <p><b>Note 2:</b> Throughout these test procedures an additional 1 dB has been added to the amplitude of the test transmission waveforms to account for variations in measurement equipment. This will ensure that the test signal is at or above the detection threshold level to trigger a DFS response.</p> <p><b>Note3:</b> EIRP is based on the highest antenna gain. For MIMO devices refer to KDB Publication 662911 D01.</p>	

**Table 4: DFS Response Requirement Values**

Parameter	Value
<i>Non-occupancy period</i>	Minimum 30 minutes
<i>Channel Availability Check Time</i>	60 seconds
<i>Channel Move Time</i>	10 seconds See Note 1.
<i>Channel Closing Transmission Time</i>	200 milliseconds + an aggregate of 60 milliseconds over remaining 10 second period. See Notes 1 and 2.
<i>U-NII Detection Bandwidth</i>	Minimum 100% of the U-NII 99% transmission power bandwidth. See Note 3.
<p><b>Note 1:</b> <i>Channel Move Time</i> and the <i>Channel Closing Transmission Time</i> should be performed with Radar Type 0. The measurement timing begins at the end of the Radar Type 0 burst.</p> <p><b>Note 2:</b> The <i>Channel Closing Transmission Time</i> is comprised of 200 milliseconds starting at the beginning of the <i>Channel Move Time</i> plus any additional intermittent control signals required to facilitate a <i>Channel</i> move (an aggregate of 60 milliseconds) during the remainder of the 10 second period. The aggregate duration of control signals will not count quiet periods in between transmissions.</p> <p><b>Note 3:</b> During the <i>U-NII Detection Bandwidth</i> detection test, radar type 0 should be used. For each frequency step the minimum percentage of detection is 90 percent. Measurements are performed with no data traffic.</p>	

**Table 5 – Short Pulse Radar Test Waveforms**

Radar Type	Pulse Width (μsec)	PRI (μsec)	Number of Pulses	Minimum Percentage of Successful Detection	Minimum Number of Trials
0	1	1428	18	See Note 1	See Note 1
1	1	Test A: 15 unique PRI values randomly selected from the list of 23 PRI values in Table 5a	Roundup $\left\{ \left( \frac{1}{360} \right) \cdot \left( \frac{19 \cdot 10^6}{\text{PRI}_{\mu\text{sec}}} \right) \right\}$	60%	30
		Test B: 15 unique PRI values randomly selected within the range of 518-3066 μsec, with a minimum increment of 1 μsec, excluding PRI values selected in Test A			
2	1-5	150-230	23-29	60%	30
3	6-10	200-500	16-18	60%	30
4	11-20	200-500	12-16	60%	30
Aggregate (Radar Types 1-4)				80%	120
<b>Note 1:</b> Short Pulse Radar Type 0 should be used for the detection bandwidth test, channel move time, and channel closing time tests.					

A minimum of 30 unique waveforms are required for each of the Short Pulse Radar Types 2 through 4. If more than 30 waveforms are used for Short Pulse Radar Types 2 through 4, then each additional waveform must also be unique and not repeated from the previous waveforms. If more than 30 waveforms are used for Short Pulse Radar Type 1, then each additional waveform is generated with Test B and must also be unique and not repeated from the previous waveforms in Tests A or B.

For example if in Short Pulse Radar Type 1 Test B a PRI of 3066 usec is selected, the number of pulses

would be  $\text{Roundup} \left\{ \left( \frac{1}{360} \right) \cdot \left( \frac{19 \cdot 10^6}{3066} \right) \right\} = \text{Roundup} \{17.2\} = 18.$

**Table 5a - Pulse Repetition Intervals Values for Test A**

Pulse Repetition Frequency Number	Pulse Repetition Frequency (Pulses Per Second)	Pulse Repetition Interval (Microseconds)
1	1930.5	518
2	1858.7	538
3	1792.1	558
4	1730.1	578
5	1672.2	598
6	1618.1	618
7	1567.4	638
8	1519.8	658
9	1474.9	678
10	1432.7	698
11	1392.8	718
12	1355	738
13	1319.3	758
14	1285.3	778
15	1253.1	798
16	1222.5	818
17	1193.3	838
18	1165.6	858
19	1139	878
20	1113.6	898
21	1089.3	918
22	1066.1	938
23	326.2	3066

The aggregate is the average of the percentage of successful detections of Short Pulse Radar Types 1-4. For example, the following table indicates how to compute the aggregate of percentage of successful detections.

Radar Type	Number of Trials	Number of Successful Detections	Minimum Percentage of Successful Detection
1	35	29	82.9%
2	30	18	60%
3	30	27	90%
4	50	44	88%
Aggregate $(82.9\% + 60\% + 90\% + 88\%)/4 = 80.2\%$			



**Table 6 – Long Pulse Radar Test Waveform**

Radar Type	Pulse Width (μsec)	Chirp Width (MHz)	PRI (μsec)	Number of Pulses per <i>Burst</i>	Number of <i>Bursts</i>	Minimum Percentage of Successful Detection	Minimum Number of Trials
5	50-100	5-20	1000-2000	1-3	8-20	80%	30

**Table 7 – Frequency Hopping Radar Test Waveform**

Radar Type	Pulse Width (μsec)	PRI (μsec)	Pulses per Hop	Hopping Rate (kHz)	Hopping Sequence Length (msec)	Minimum Percentage of Successful Detection	Minimum Number of Trials
6	1	333	9	0.333	300	70%	30

**DFS Measurement System**

BACL DFS measurement system consists of two subsystems: (1) The radar signal generating subsystem and (2) the traffic monitoring subsystem.

**System Block Diagram**

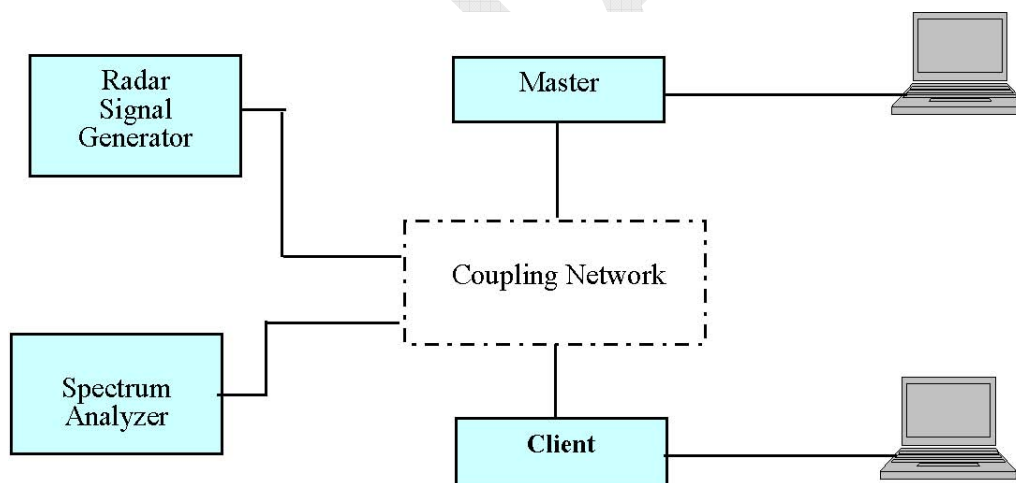

**Conducted Method**

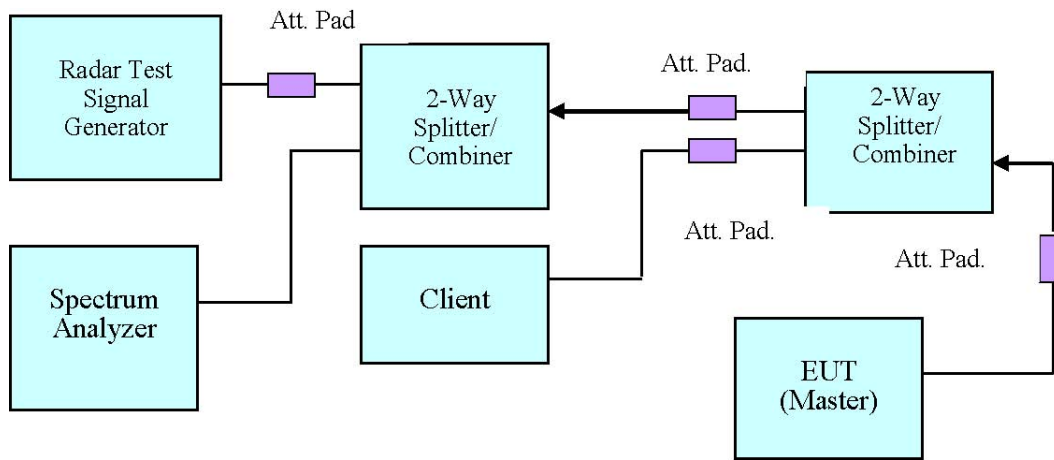

**Setup for Master with injection at the Master**

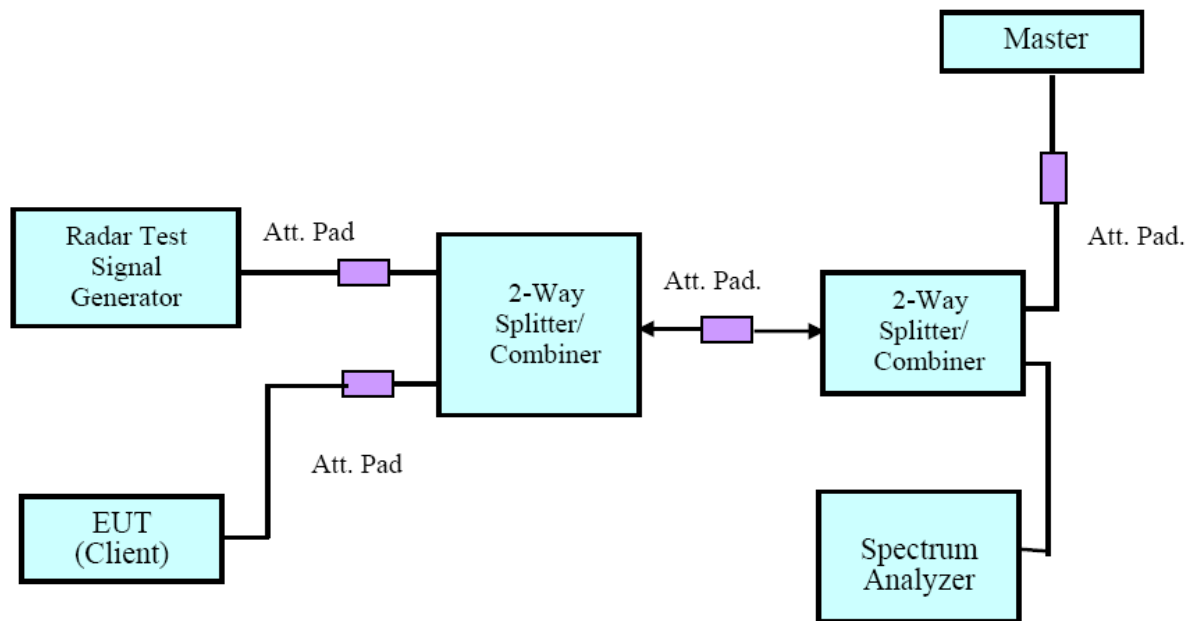

**Setup for Client with injection at the Master**

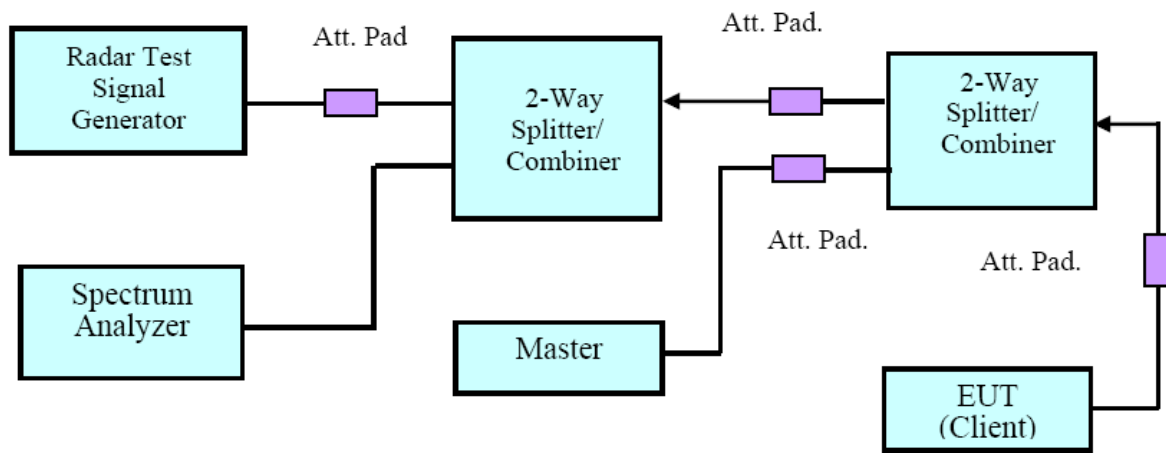

Setup for Client with injection at the Client

**Radiated Method**

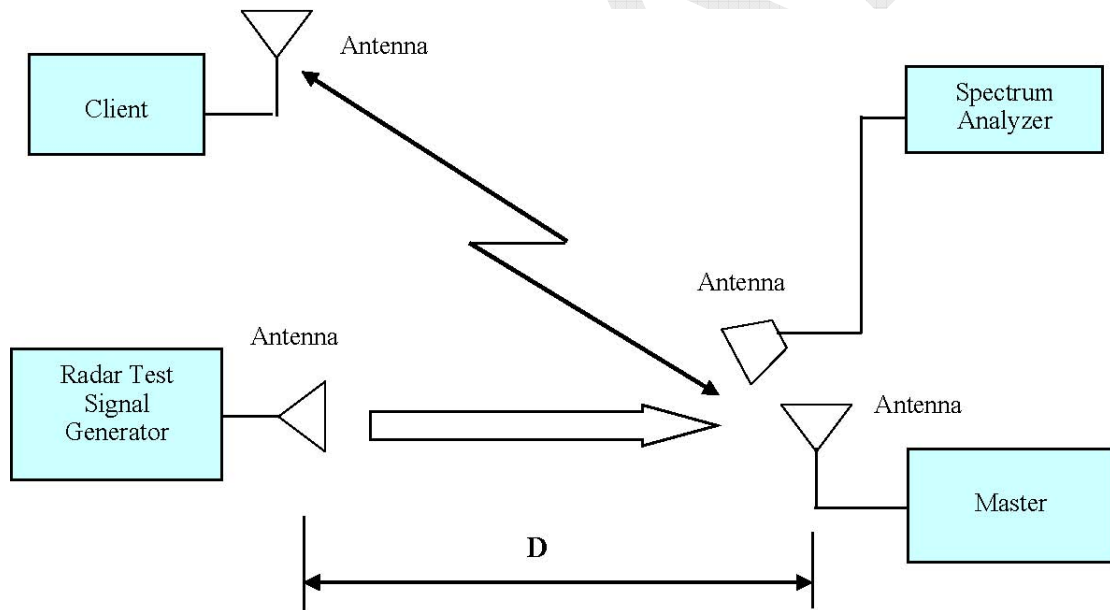

**Test Procedure**

A spectrum analyzer is used as a monitor verifies that the EUT status including Channel Closing Transmission Time and Channel Move Time, and does not transmit on a Channel during the Non-Occupancy Period after the diction and Channel move. It is also used to monitor EUT transmissions during the Channel Availability Check Time.

## TEST RESULTS

### Description of EUT

The EUT operates in 5250-5350 MHz and 5470-5725 MHz range.

The maximum EIRP of the master is 21.92dBm<23 dBm, Therefore the required interference threshold level is -62 dBm, the required radiated threshold at antenna port is -62dBm.

The calibrated radiated DFS detection threshold level was set to -64 dBm, which was more stringent.

WLAN traffic is generated by Laptop, The data streamed from the Access Point to the EUT.

### Test Equipment List and Details

Manufacturer	Description	Model	Serial Number	Calibration Date	Calibration Due Date
Rohde & Schwarz	OSP120 BASE UNIT	OSP120	101247	2016-07-04	2017-07-03
Rohde & Schwarz	SIGNAL ANALYZER	FSV40	101116	2016-07-04	2017-07-03
Rohde & Schwarz	VECTOR SIGNAL GENERATOR	SMBV100A	261558	2016-07-04	2017-07-03
Rohde & Schwarz	SIGNAL GENERATOR	SMB100A	110390	2016-07-04	2017-07-03
Rohde & Schwarz	OSP120 BASE UNIT	OSP120	101247	2016-07-04	2017-07-03
Mini-circuits	Splitter/Combiner	ZX10-2-1252+	N/A	N/A	N/A
ETS	Horn Antenna	3115	6229	2016-01-11	2019-01-10
ETS	Horn Antenna	3115	00066542	N/A	N/A
Agilent	Spectrum Analyzer	E4440A	SG43360054	2016-12-08	2017-12-08

Note: E4440A was used for Non-Occupancy Period test in 2017-03-15.

\* **Statement of Traceability:** Bay Area Compliance Laboratories Corp. (Kunshan) attests that all calibrations have been performed, traceable to National Primary Standards and International System of Units (SI).

**Radar Waveform Calibration**

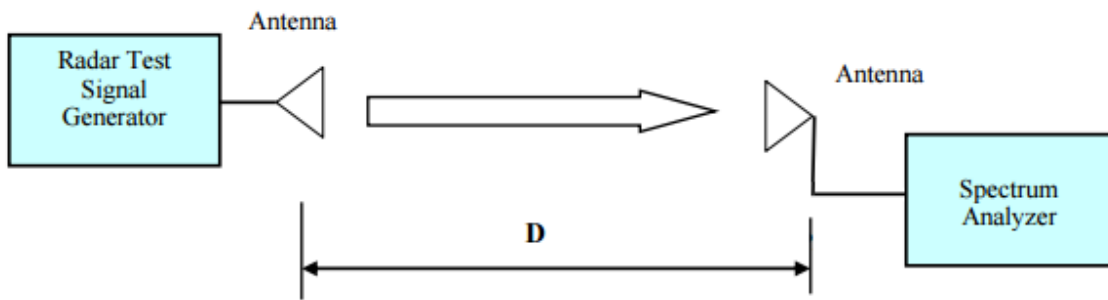

**Radiated Calibration Setup Block Diagram**

**Test Environmental Conditions**

<b>Temperature:</b>	26.1~26.3 °C
<b>Relative Humidity:</b>	32~41 %
<b>ATM Pressure:</b>	100.8~101.1 kPa

*The testing was performed by Edison Hu from 2016-12-07 to 2017-03-15.*

Plots of Radar Waveforms

5280 MHz:

### Radar Type 0

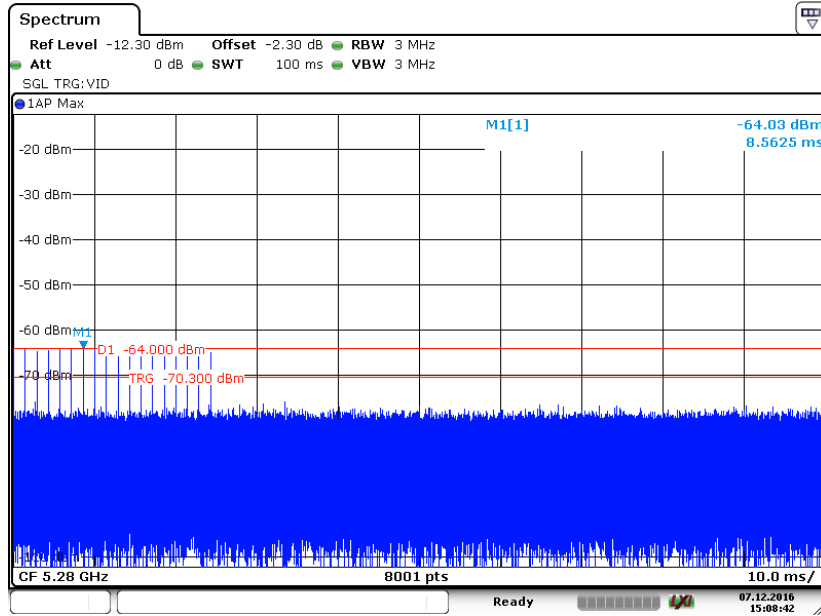

Date: 7 DEC. 2016 15:08:42

5500 MHz:

### Radar Type 0

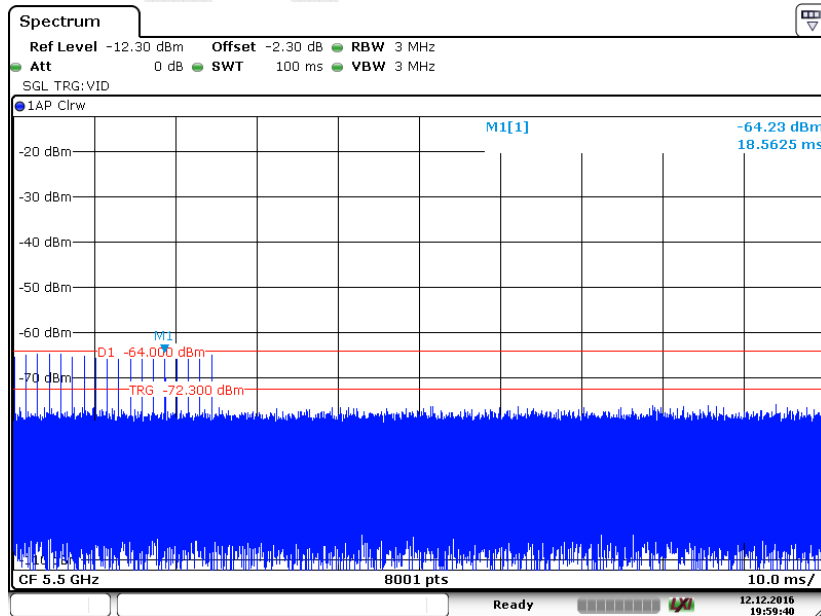

Date: 12 DEC. 2016 19:59:40

## CHANNEL MOVE TIME AND CHANNEL CLOSING TRANSMISSION TIME

### Test Procedure

Perform type 0 short pulse radar waveform, repeat using a long pulse radar type5 waveform. The aggregate channel closing transmission time is calculated as follows:

Aggregate Transmission Time = N\*Dwell Time

N is the number of spectrum analyzer bins showing a device transmission Dwell Time is the dwell time per bin (i.e. Dwell Time = S/B, S is the sweep time and B is the number of bin, i.e. 8192)

### Test Results

Frequency (MHz)	Bandwidth (MHz)	Radar Type	Results
5270	40	Type 0	Compliant
5510	40	Type 0	Compliant

Please refer to the following tables and plots.

**5270 MHz**

Type 0 radar channel move time result:

Item	Time (s)	Limit (s)
Closing Move Time	<<10	10

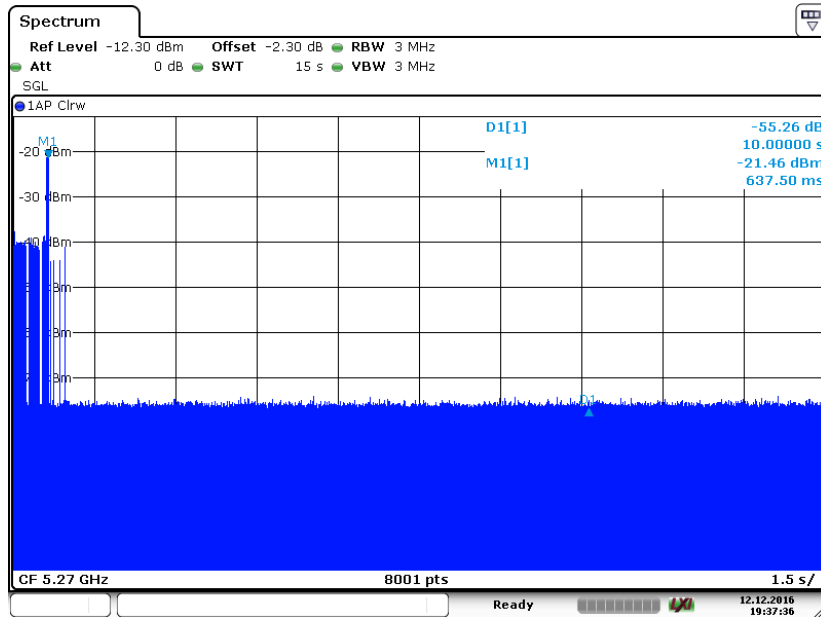

Date: 12.DEC.2016 19:37:36

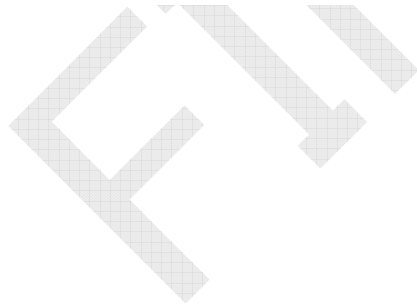



Type0 radar channel closing transmission time result:

Item	Time (ms)	Limit (ms)
Channel Closing Transmission Time	16.87	200
Aggregate Transmission Time after 200ms	3.75	60

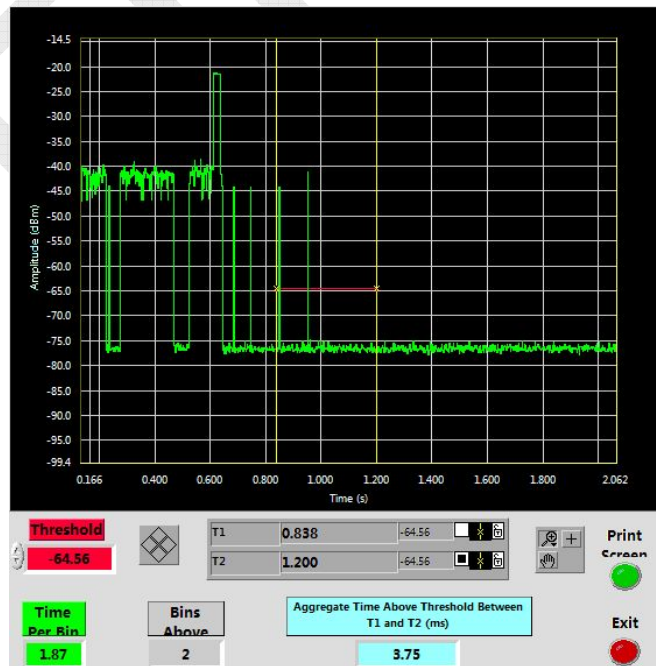
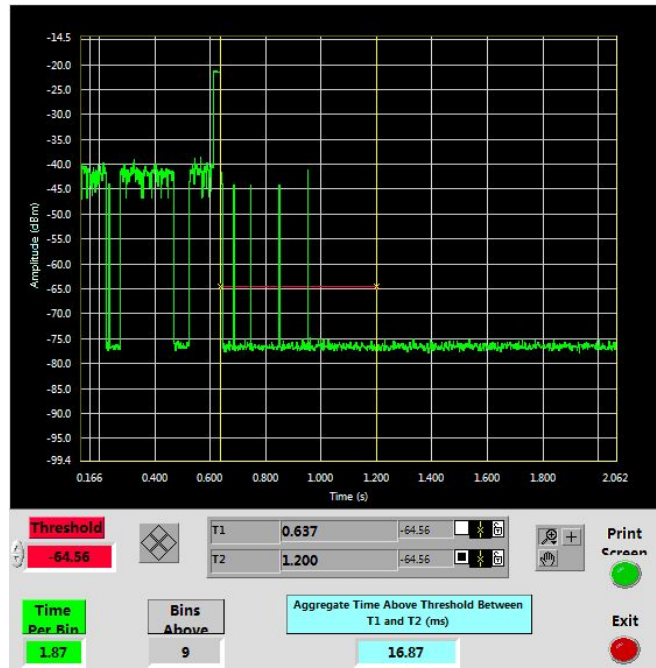

**5510 MHz**

Type 0 radar channel move time result:

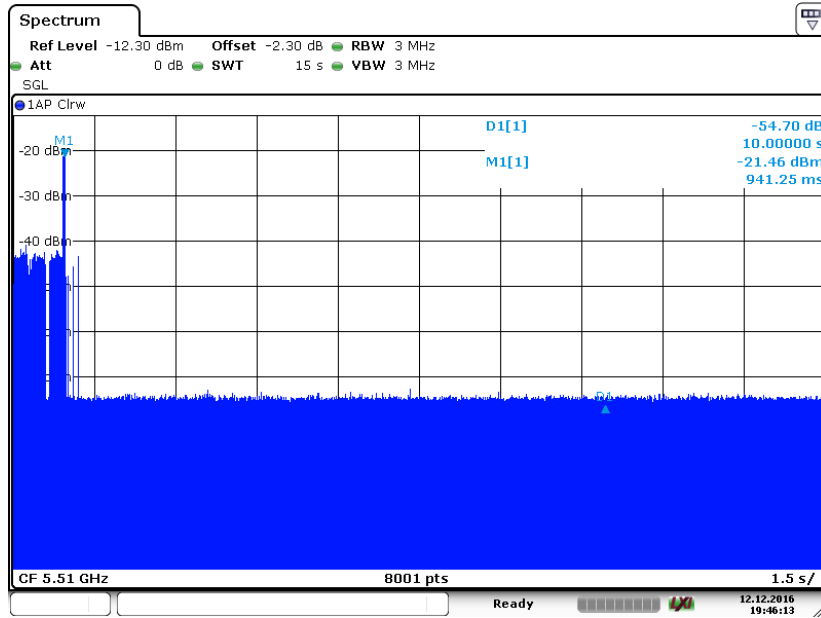

Date: 12.DEC.2016 19:46:14

FEM

Type0 radar channel closing transmission time result:

Item	Time (ms)	Limit (ms)
Closing Transmission Time	9.37	200
Aggregate Transmission Time after 200ms	1.87	60

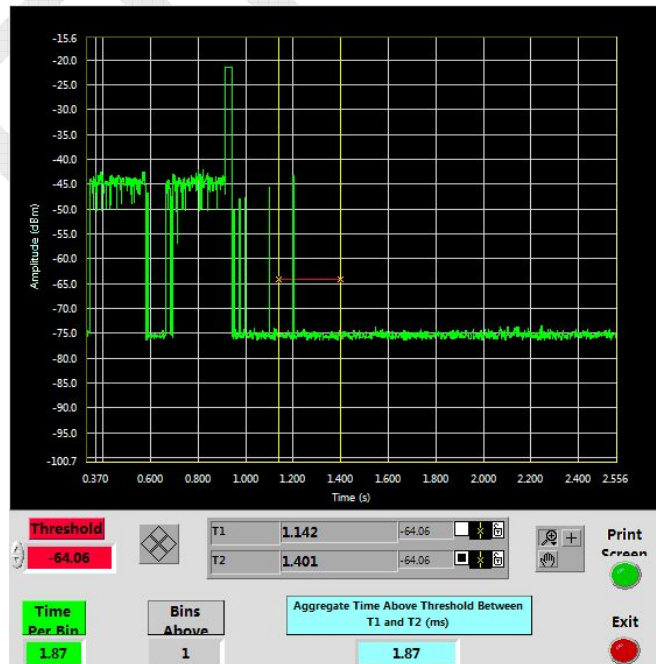
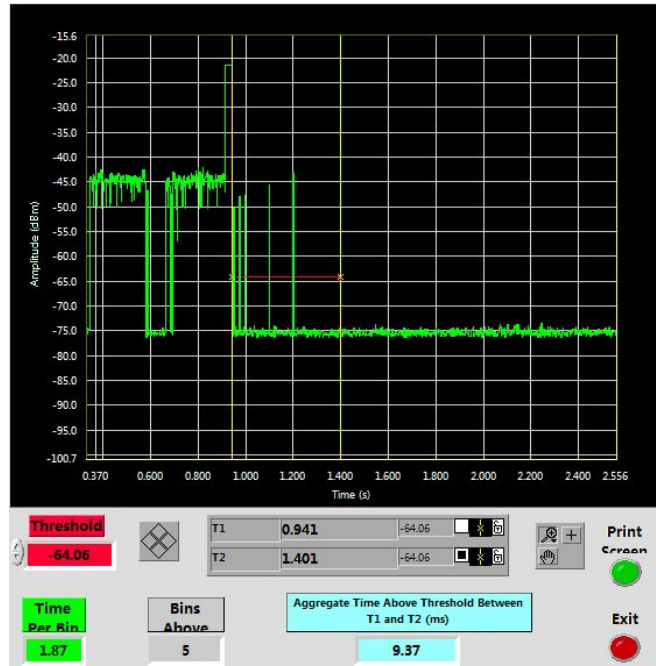

---

**NON-OCCUPANCY PERIOD**

---

**Test Procedure**

Measure the EUT for more than 30 minutes following the channel close/move time to verify that the EUT does not resume any transmissions on this channel. Provide one plot to demonstrate no transmission on the channel for the non-occupancy period (30 minutes observation time)

**Test Result**

Frequency(MHz)	Bandwidth (MHz)	Spectrum Analyzer Display
5270	40	No transmission within 30 minutes
5510	40	No transmission within 30 minutes

Please refer to the following plots.

5270 MHz

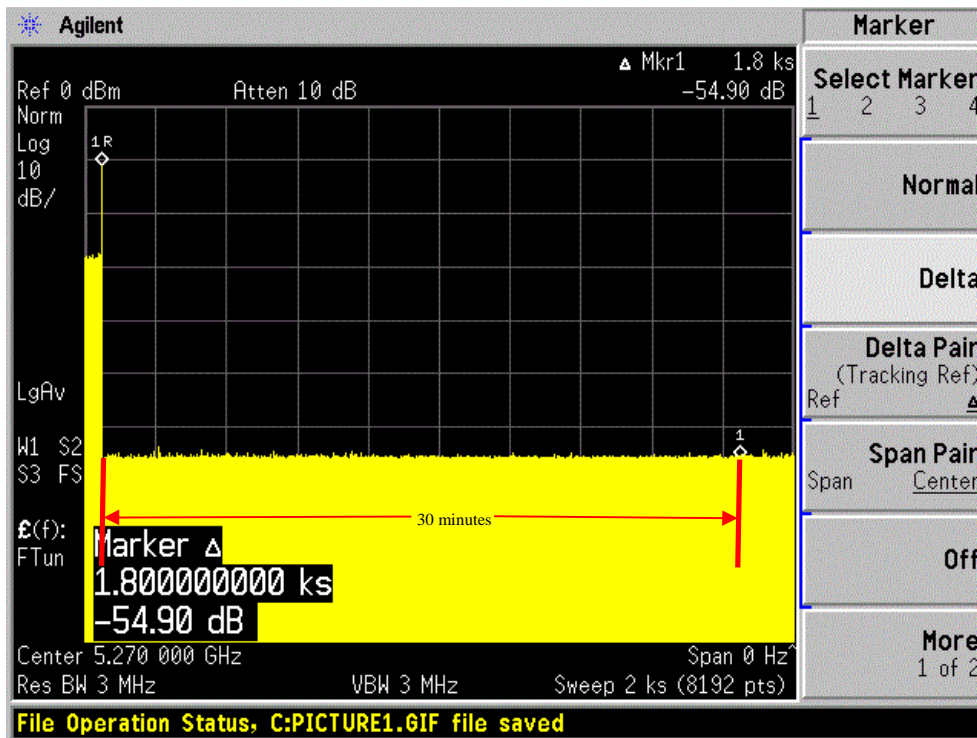

5510 MHz

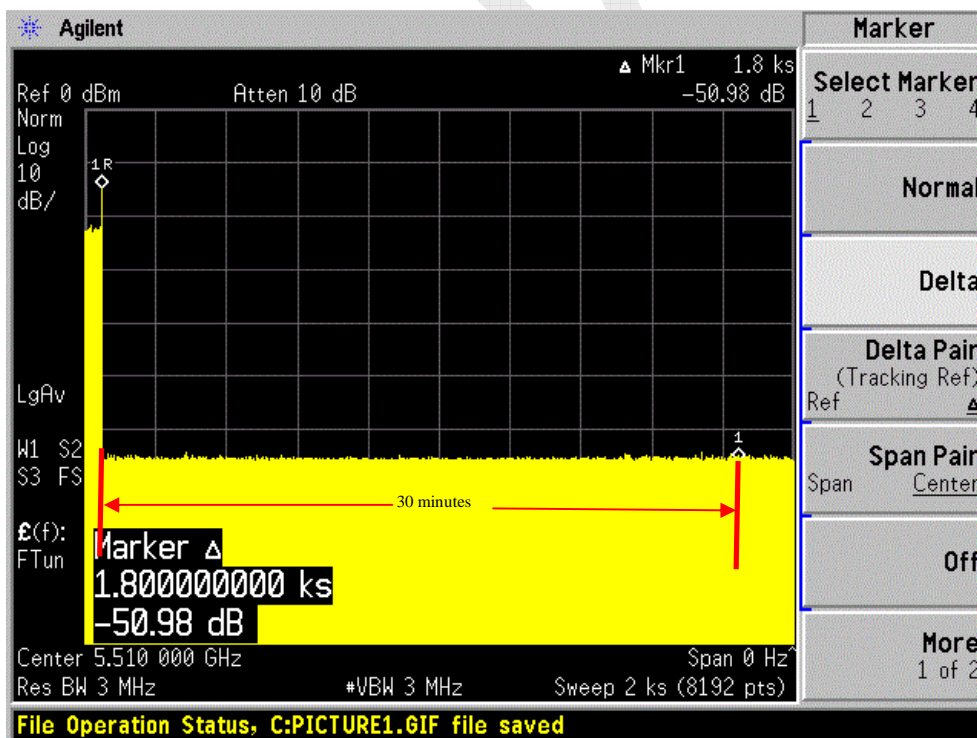

---

## APPENDIX A - TEST SETUP PHOTOGRAPHS

---

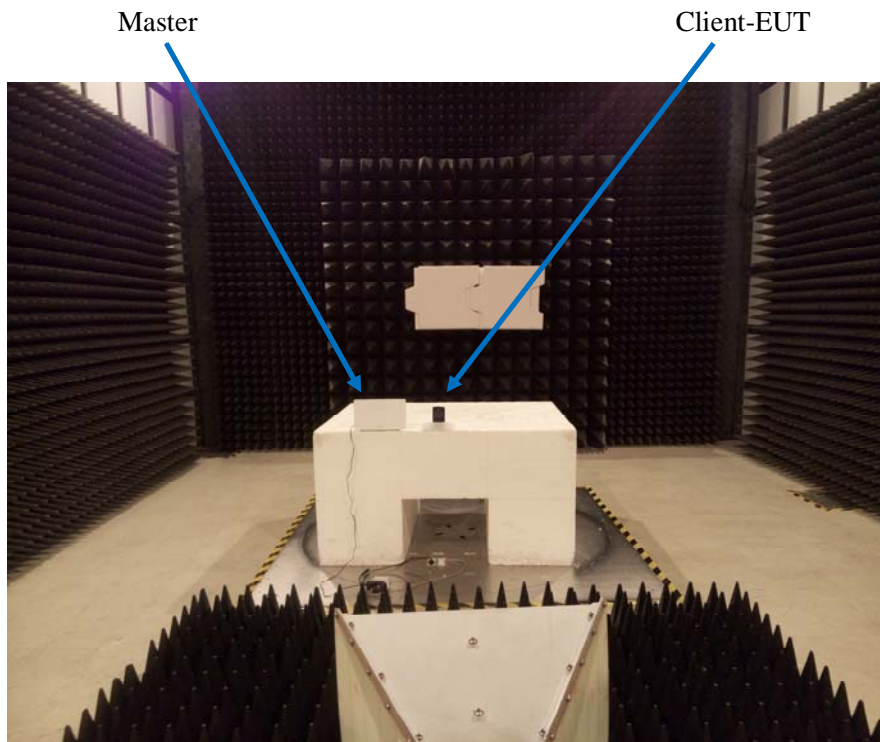

\*\*\*\*\* END OF REPORT \*\*\*\*\*