

ingenico GROUP

Model:AXIUM DX8000-BASE-W2

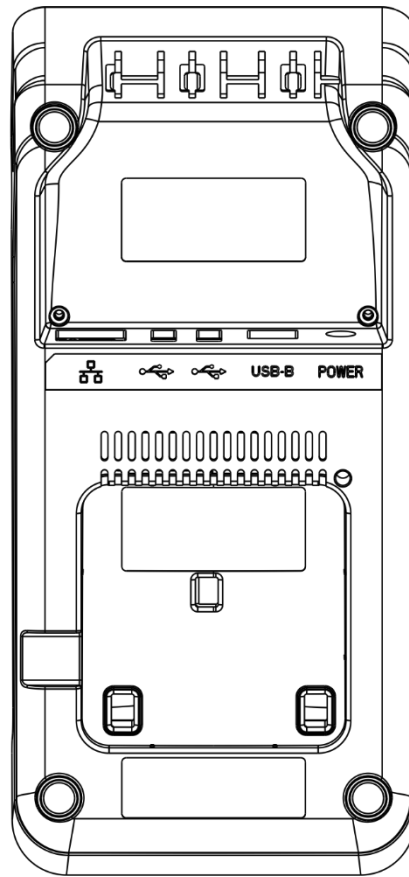
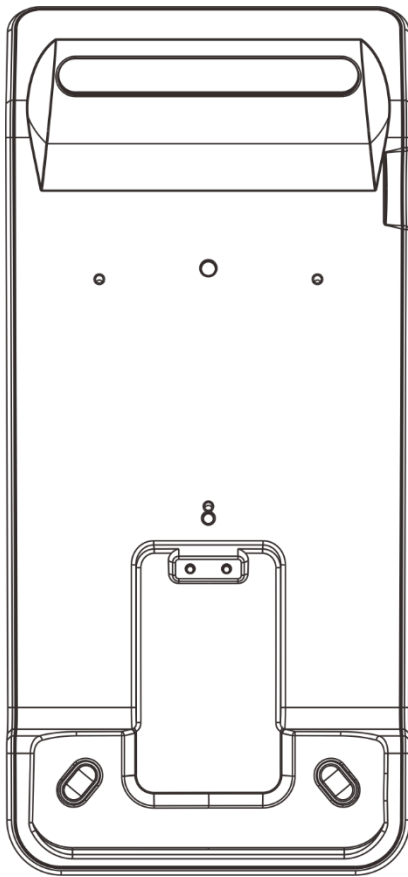

Contents

1. Product Introduction	3
1.1 Open Package Inspection	3
1.2 Device Introduction	3
1.3 Interface definition.....	4
2. Product Technology Features	5
2.1 Product Technology Specifications	5
2.2 Environmental Conditions	5
2.3 Product Functions	5
3. WiFi connection	6
3.1 Connect DX8000 to the base WiFi.....	6
3.2 Web Setting of base.....	6
3.3 Restore factory Setting	9
4. Pairing connection.....	9
4.1 Prepare for Base Pairing	9
4.2 Pair method.....	10
4.3 Unpair method.....	10
4.4 Ethernet Parameter Setting.....	11
4.5 WLAN Parameter Setting	11
4.6 Advanced Setting	12
4.7 Operating Mode.....	12
4.7.1 Gateway Mode.....	12
4.7.2 Bridge Mode	13
4.7.3 WiFi Repeater Mode	13
4.8 Management Setting	14
5. Fixing of the base.....	15
6. FAQs	17
7. Notes	18
8. Delivery and Storage	18
9. Power Adapter	18
10. Standard	19

1. Product Introduction

1.1 Open Package Inspection

Open the package to check if there are any disabling masks or transportation damage in the terminals and fittings.

Procedures :

- 1) Open the package
- 2) Check the following items(Subject to actual product configuration)
 - Base host
 - Product instruction
 - 12V/3.33A power adapter
 - AC power cable
- 3) Save the transportation package and packing material for second use.

1.2 Device Introduction

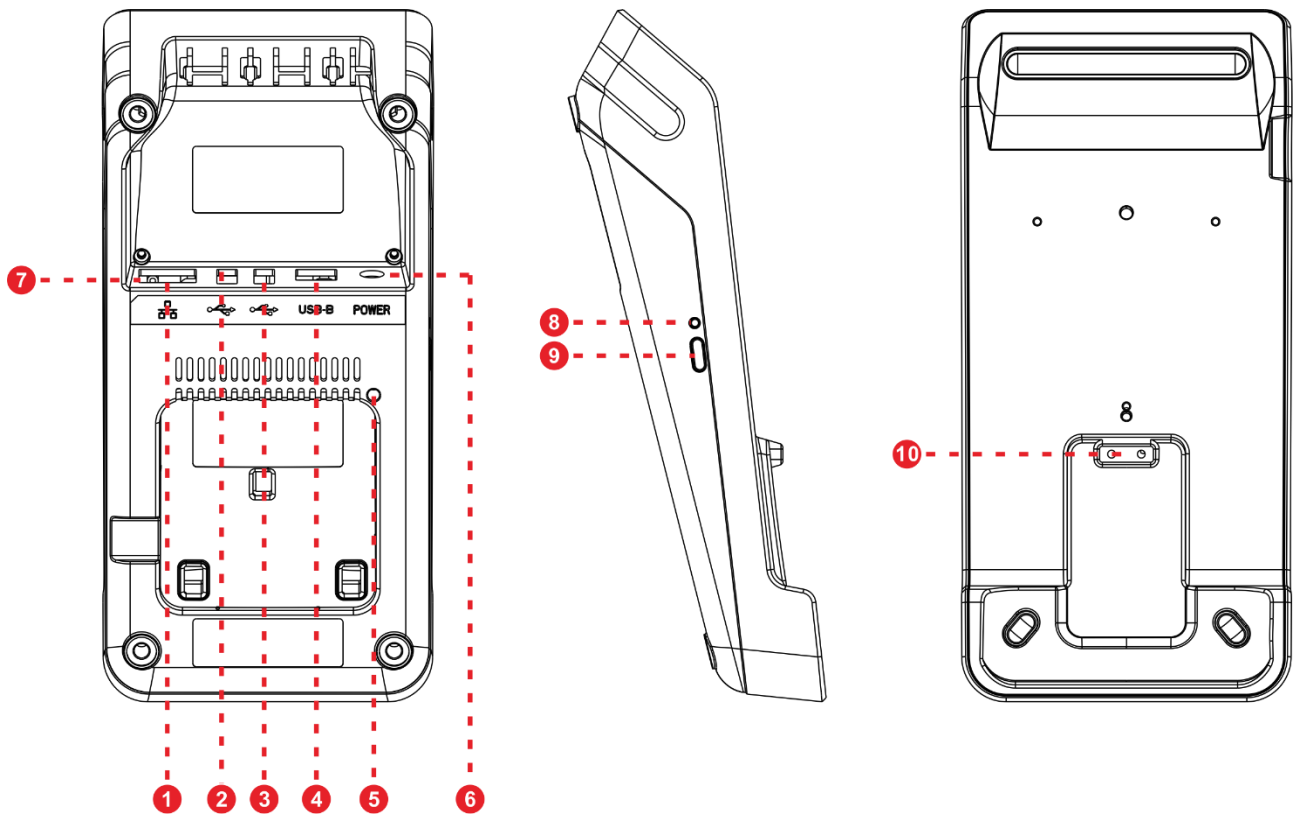

1. RJ45 Network Interface 2. USB-TYPE A 3. USB-TYPE A
4. USB-TYPE B 5. Reset Button 6. DC12v JACK Power Interface
7. Network LED link&active 8. Two color Indicator lights 9. Pairing Button

10.DX8000 Charging Contact

1.3 Interface definition

1) RJ45 interface

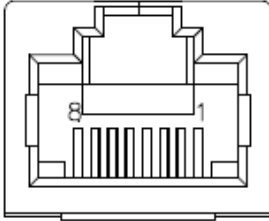

Sequence	RJ45Signal
1	ETH_TX+
2	ETH_TX-
3	ETH_RX+
4	NC
5	NC
6	ETH_RX-
7	NC
8	NC

2) USB-TYPE A interface

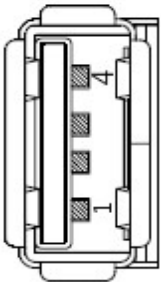

Sequence	USB-TYPE A Signal
1	VBUS 5.0V
2	D-
3	D+
4	GND

3) USB-TYPE B interface

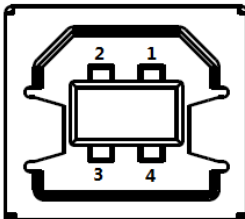

Sequence	USB-TYPE BSignal
1	Not connect
2	D-
3	D+
4	GND

2. Product Technology Features

2.1 Product Technology Specifications

Port	a DC12V JACK port a RJ45 network port two USB A HOST port supporting USB2.0 a USB B DEVICE port supporting USB2.0
Power	Every USB HOST output: 5.0VDC 0.5A Charge output: 5.0VDC 2.0A Power adapter: input 100-240V AC, 50/60Hz; output 12V DC 3.33A
Size and Weight	Size : 193.8mmx89mmx38.6mm Net Weight : 0.20kg Gross Weight : 0.70kg

2.2 Environmental Conditions

Environmental conditions for running, storing and delivering the product :

Temperature	Running	0°C ~ 40°C
	Storage and Delivery	-20°C ~ 70°C
Humidity	Running	10% ~ 90%
	Storage and Delivery	5% ~ 90% (40°C)
Atmospheric pressure		86kPa ~ 106 kPa; Below 2000 meters above sea level

2.3 Product Functions

The base has three main functions as below:

- DX8000 charging: Connect the base with the power adapter, then place DX8000 on the base to get charged.
- Serves as extended communication ports of DX8000: Network port, USB port, etc.
- Typical applications: Enables DX8000 to communicate with host computer via USB port, and get Ethernet through Network port.

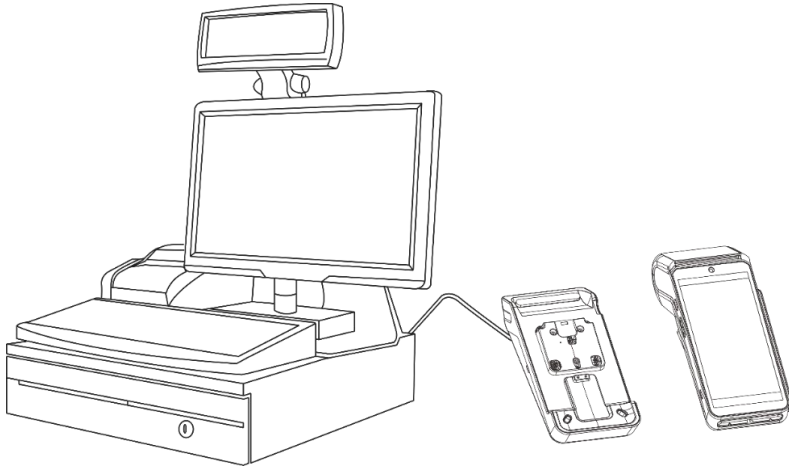

3. WiFi connection

3.1 Connect DX8000 to the base WiFi

- Power on the base.
- Check the SSID and password from the label on the back of base.
- Click “Settings” menu on DX8000, and then click “Network and Internet”, enter “Wi-Fi” and select the base SSID to connect.(step 1~4)
- After that , DX8000 can use the RJ45 network of the base.

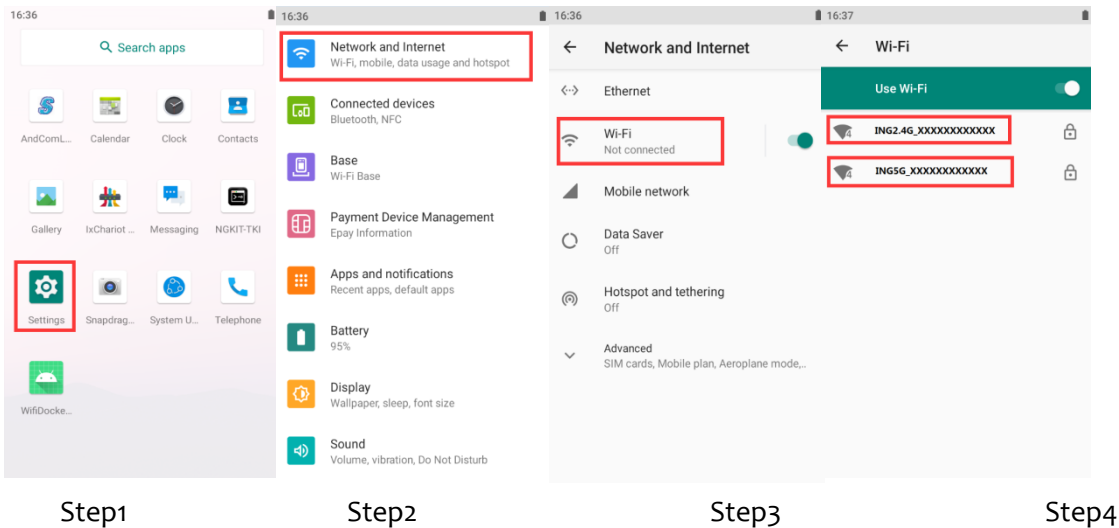

3.2 Web Setting of base

The base can be set from the web.

- Use a computer to connect the base via WiFi.
- The web setting IP of base is 192.168.47.1. Login name is Admin. Password is DX8000BASE.
- User can get the status of base on the status page.

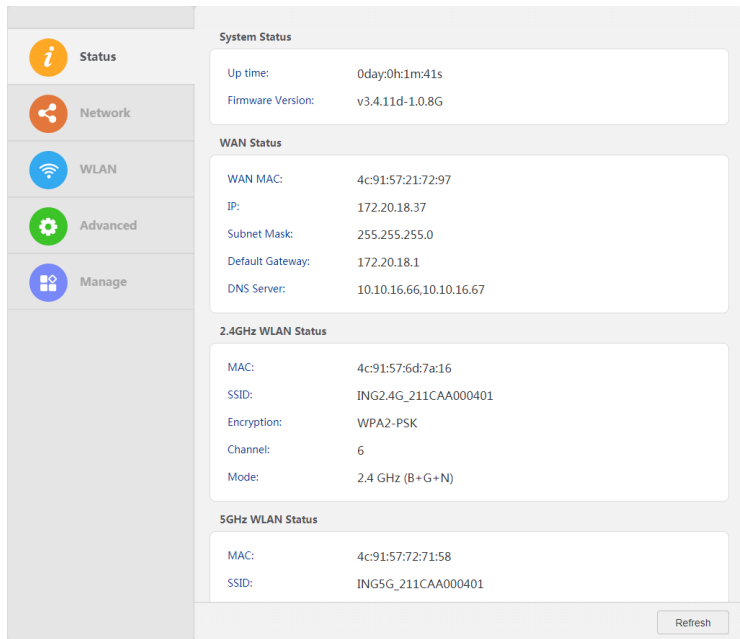

- User can get and change the Ethernet parameter on the Network page.

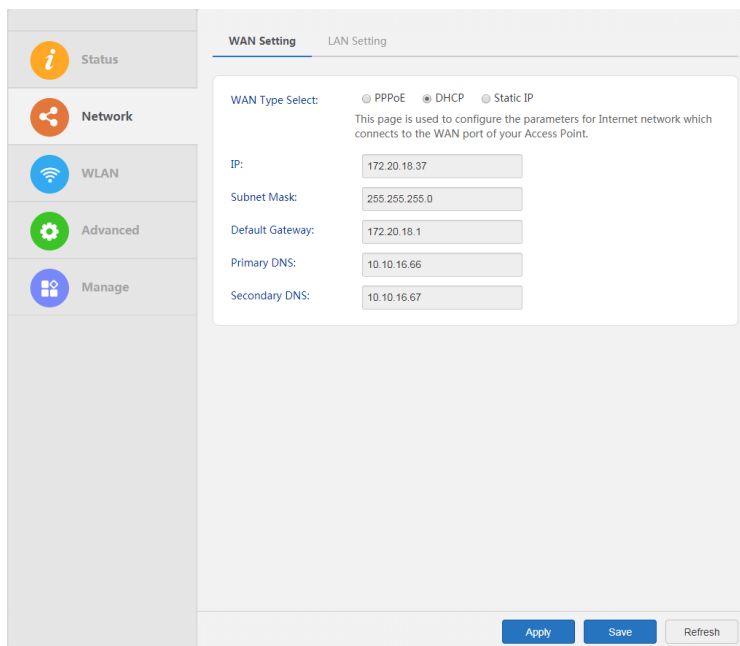

- User can get and change the WLAN parameter on the WLAN page.

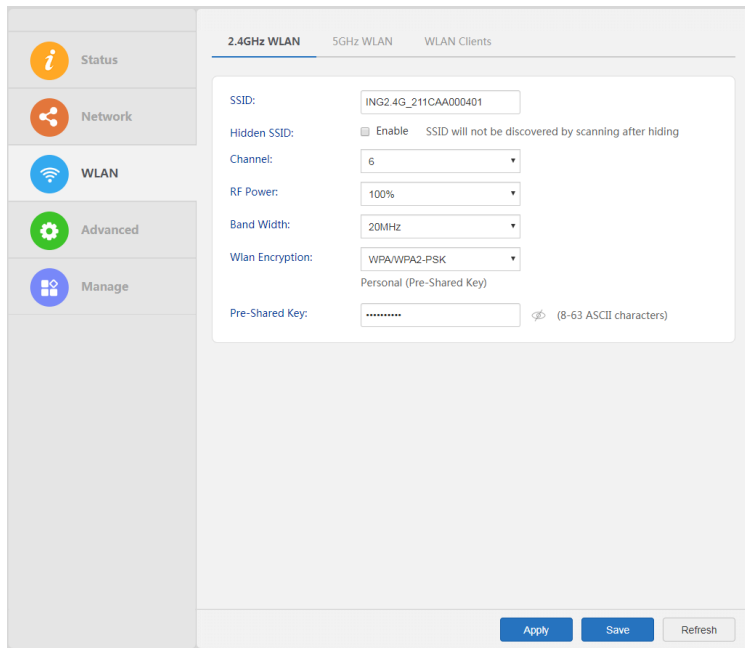

- User can change the operating mode, enable DMZ or set static DHCP on the Advanced page.

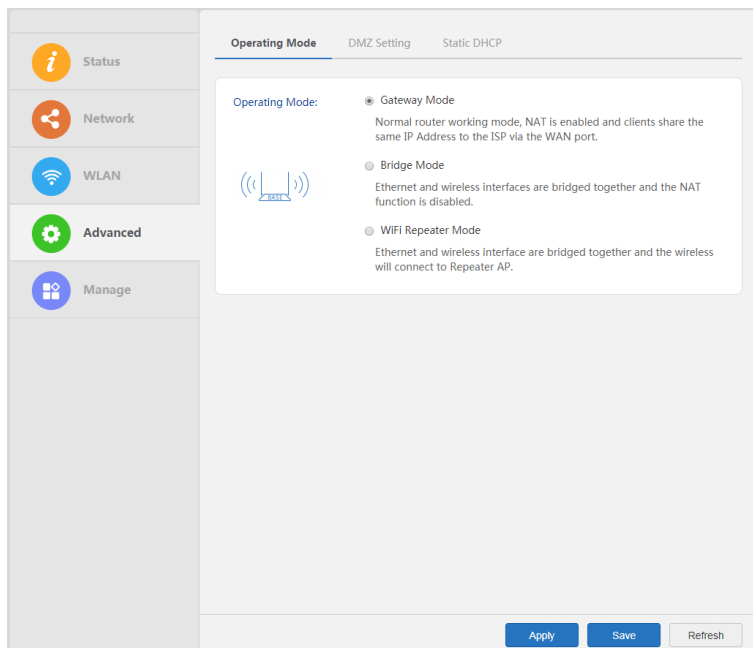

- User can update the firmware of base, save and reload the settings, change the password on the Manage page.

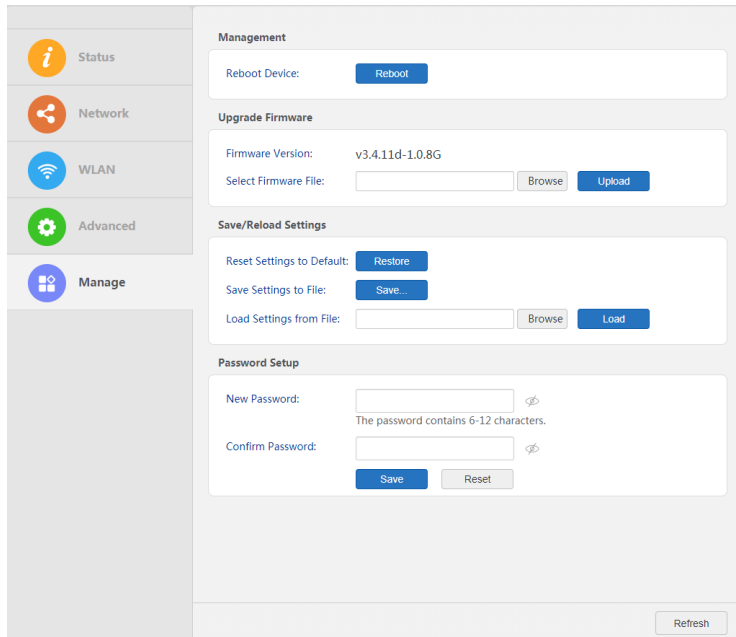

3.3 Restore factory Setting

- Use sharp to click the RESET button to restore the factory setting of the base.
- The position of RESET button is below.

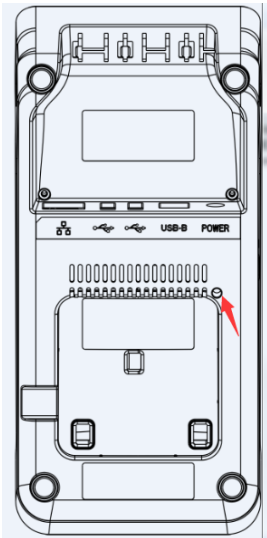

4. Pairing connection

- If DX8000 want to use the USB ports on the base, it should be paired to the base.

4.1 Prepare for Base Pairing

- Only one DX8000 can use the USB ports of the base at the same time.
- If the red indicator light is on, it indicates the base is available for pairing.
- If the green indicator light is on, it indicates the base is successfully paired. If the base is to be paired with another DX8000, long press on the [Pairing] button to clear the pairing record .When the red indicator light is on,pair another DX8000 with the base.

- Illumination of two color indicator lights:

SN	Light Condition	Base Status
1	Red light on	Base to be paired
2	Green light flashing	Base paired but disconnected with DX8000
3	Green light on	Base paired and connected with DX8000
4	Red light flashing	Base in upgrading

4.2 Pair method

- First, connect DX8000 to the base via chapter 3.1.
- Click “Settings” menu on DX8000, and then click “Base”, input the web password [Step1].
- Click the grey button beside the SSID “ING2.4G_XXXXXX” to pair [Step2].
- After pairing, we can check the ports of base in the menu. [Step3].

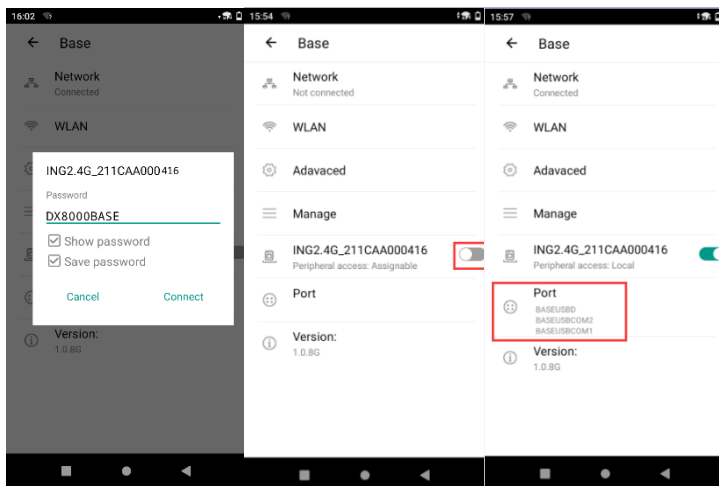

Step1

Step2 Step3

4.3 Unpair method

- Only the paired DX8000 could be unpaired with the base. When DX8000 unpairs the base, the base will change its conditions to “unpaired” with the red light on.
- Click the blue button besides the SSID [Step1]. Click “YES” [Step2] to unpair the base with DX8000:

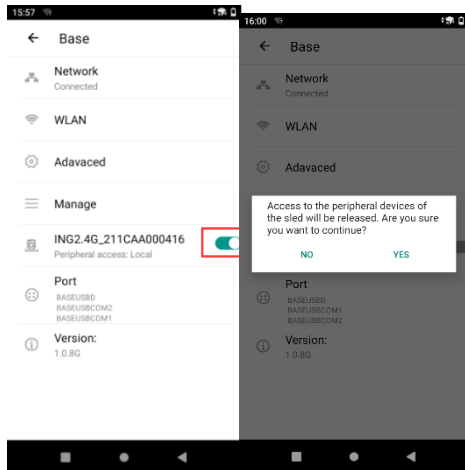

Step1

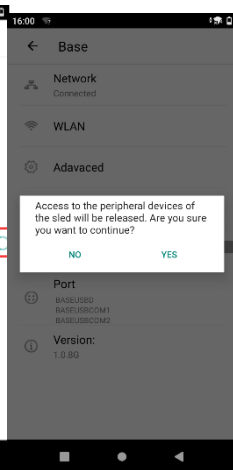

Step2

4.4 Ethernet Parameter Setting

Procedures:

- Tab on “Network” enter WAN Setting or LAN Setting menu.
- Enter WAN Setting to get and set the WAN parameter.
- Enter LAN Setting to get and set the LAN parameter.

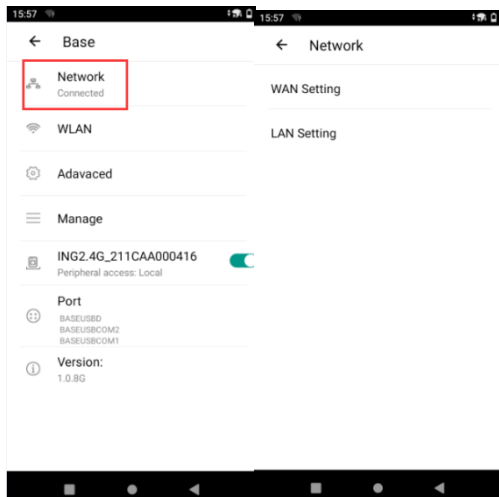

Step 1 Step 2

4.5 WLAN Parameter Setting

- Enter WLAN menu.[Step1]
- AXIUM DX8000-BASE-W2 has 2.4G WLAN and 5G WLAN,so we can click “2.4GHz WLAN” to set 2.4G parameter and click “5GHz WLAN” to set 5GHz WLAN.[Step2]
- We can set channel,RF power,band width and get WLAN MAC on the menu.[Step3,4]

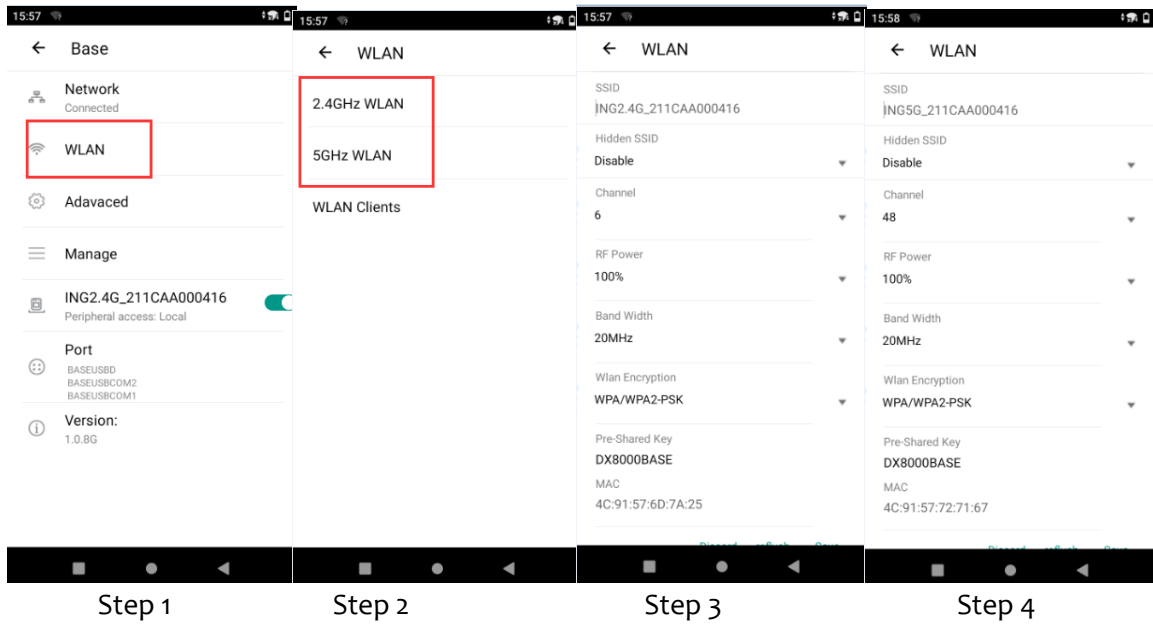

4.6 Advanced Setting

- Enter advanced menu.
- We can set the operating mode, DMZ and static DHCP of the base [Chart 1].
- In operating mode, we can set the base work in different mode [Chart 2].
- We can set DMZ [Chart 3] and add static DHCP [Chart 4].

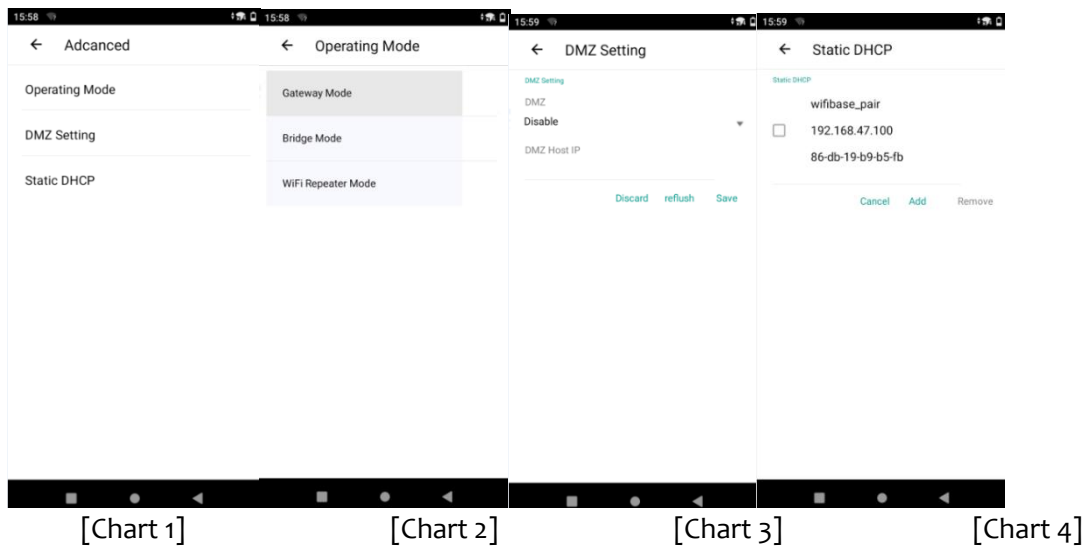

4.7 Operating Mode

4.7.1 Gateway Mode

- ADSL/ONU distribute the IP to base ETH port.
- Base distribute the IP to DX8000.

- ADSL/ONU and DX8000 are not in the same network segment .



4.7.2 Bridge Mode

- Base distribute the IP to the computer and DX8000.
- They are in the same network segment .

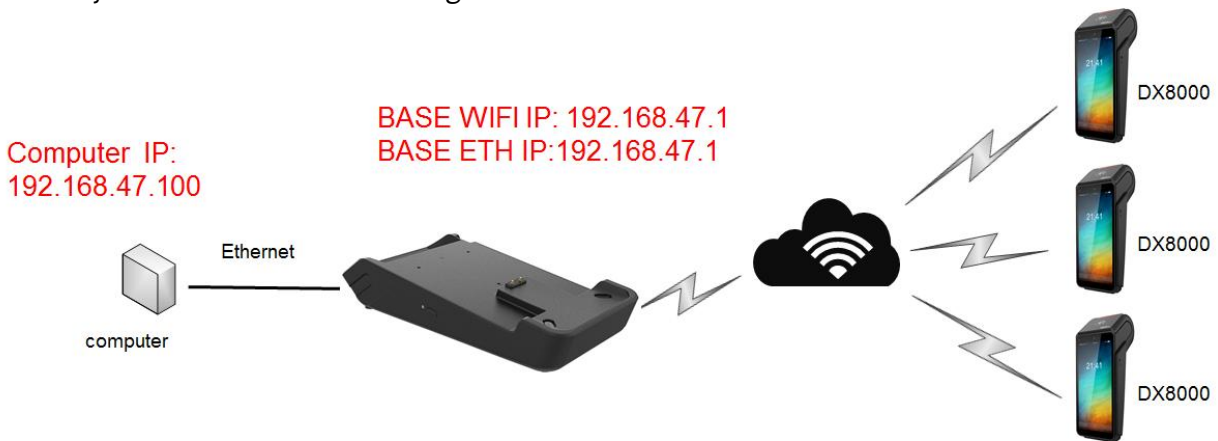

4.7.3 WiFi Repeater Mode

- It is a mode to expand coverage of base.
- For example , DX8000 is too far away to connect Base A. So we can put Base B between Base A and DX8000.
- Set Base B to repeat the Base A. DX8000 can connect to internet via Base B.

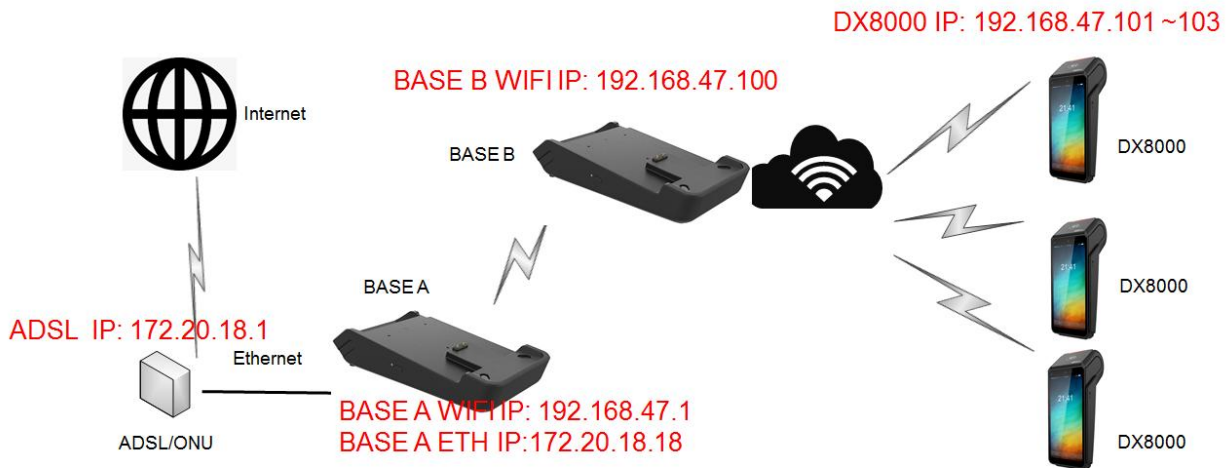

4.8 Management Setting

- In management menu, we can upgrade the firmware of base.
- First, we use software manager to install the wifidockfirmware.apk in DX8000, as follows:

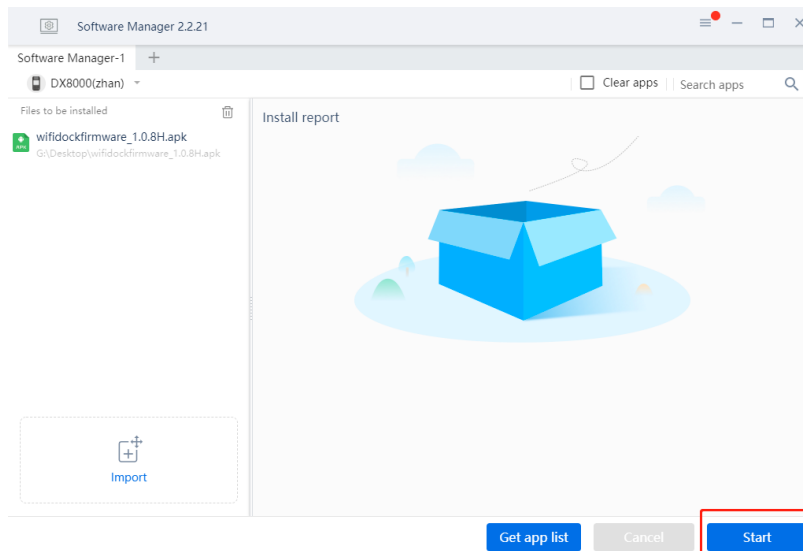

- Second, we pair the base with DX8000. We can get current version and latest version information and click upload to upgrade the firmware [Step1]. Wait for upgrading [Step2]. And get the successful tips [Step3]. Check the version of the base [Step4].

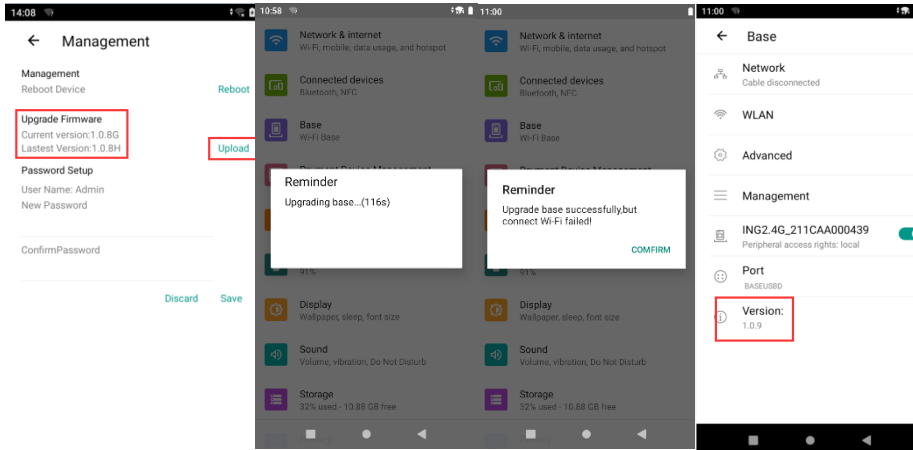

[Step1][Step2][Step3][Step4]

5. Fixing of the base

In some scenes, we want to fix the base and the DX8000 to the table.

The fixing structure is not standard configuration. We need to buy it from the agent.

Installation procedures as below:

- First, fix the space block on the table with screws.
- Second, fix the Base Fixing structure on the space block with three screws.
- Third, put the base on the structure to lock it.
- Fourth, fix the Base Fixing structure on the base with three screws.
- Fifth, change the battery cover of DX8000 and put DX8000 on the base to lock it.

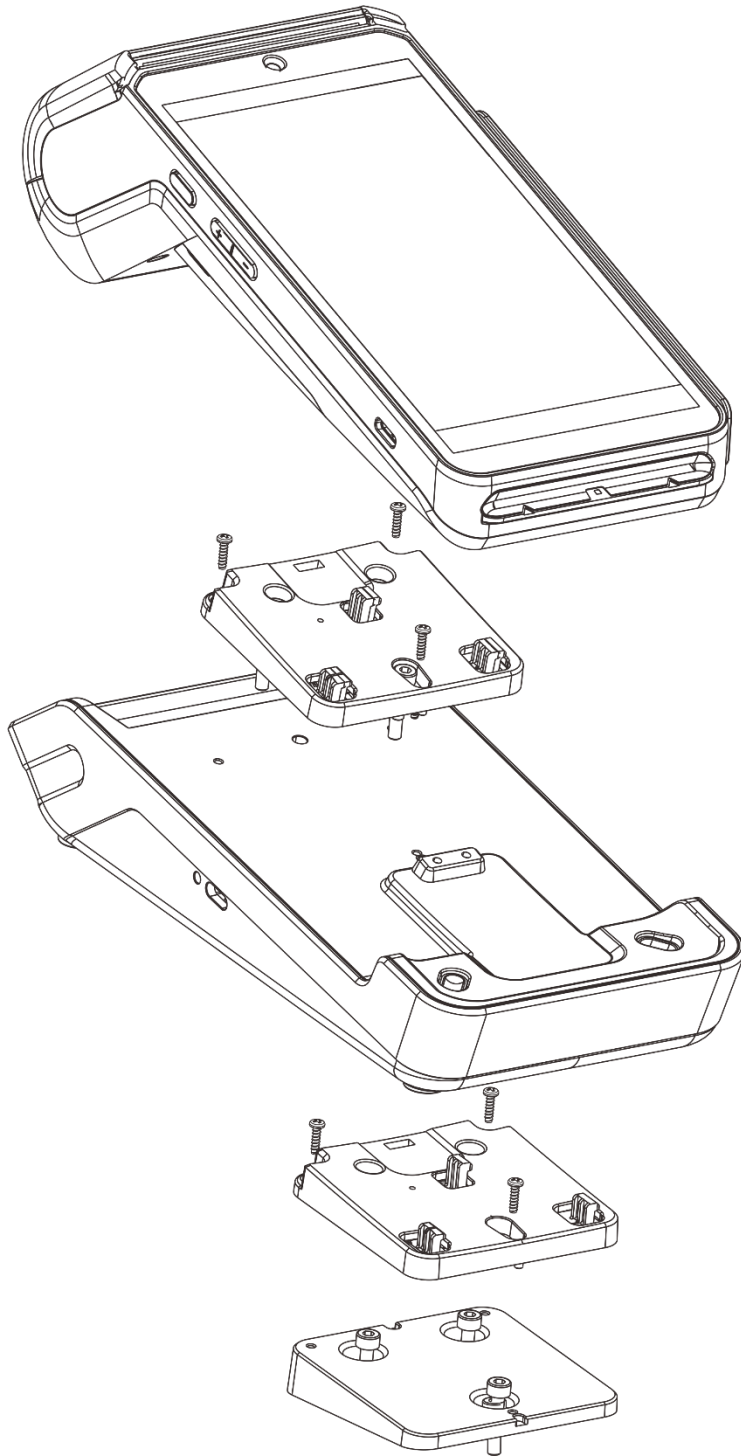

- If we want to unfix the base and DX8000, we can use screwdriver to push the area of the structure to unfix them.

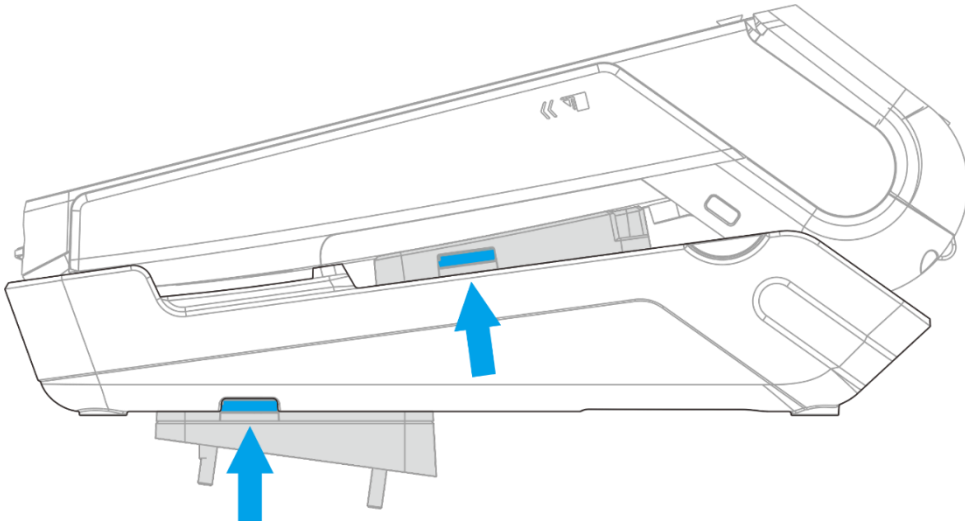

6. FAQs

Q1: The base fails to connect DX8000.

- Cause1: DX8000 WLAN is not yet opened.
- Solution: Open WLAN via the drop-down box of DX8000.
- Cause 2: DX8000 is placed too far away from base.
- Solution: Place and pair the devices within 10 meters.
- Cause 3: The password of DX8000base is changed .
- Solution: Input the correct password ,or restore factory setting to get the default password.

Q2: It displays that base is not connected to DX8000, while the green indicator light of base flashes.

- Cause1: The two devices are too far away from each other that its connection fails.
- Solution: Place the two devices near, better within 10 meters.
- Cause 2: The DX8000 is not paired to the base.
- Solution:Only one DX8000 can be paired to the base at the same time .The paired DX8000 may not be this one.We can pair this DX8000 to the base according to Q4.

Q3: Device plugged in USB port cannot be recognized.

- Cause: The USB port only supports for products of company such as the scanning gun (e.g. BR200-B), scanning box(e.g.DCS20), E830MIS, and USB devices of serial ports such as CH34x, PL230, FTDI, CP210X. Other devices are not supported for now.
- Solution: If new USB devices need to be developed, please consult after-sales personnel.

Q4: How to pair one paired base with another DX8000?

- Solution: After powering on the base, long press on [Pairing] button for 3 secs. After that, the base is in “unpaired” status with red indicator light on. Perform pairing operations on DX8000. The base only save the information of latest DX8000 successfully paired with.

Q5: Why mobile phone can not search the 5G WiFi?

- Solution: Check whether mobile phone can support 5G WiFi.

7. Notes

- ✧ Prevent the terminal from sun exposure, high temperature, moisture and other mean conditions.
- ✧ Cut off the power before cleaning the device and wipe the main body with dry cloth.
- ✧ When the following abnormal phenomena occur, stop running the device immediately, cut off the power supply, and report to the service provider as soon as possible:

1) harsh noise heard during operation.

2) impurities or water found in the machine.

3) Unpleasant smell found during operation.

8. Delivery and Storage

Deliver the device in normal way, avoiding rain and snow, sun exposure and mechanical impact.

The product should be stored in the original box. The box should be at least 15cm away from the floor, at least 50cm from the wall, heat source, cold source, window or air inlet.

9. Power Adapter

The base can only be connected to the adapter which is provided with AXIUM DX8000-BASE-W2.

WARNING

The power adapter provided is specially designed for ingenico AXIUM DX8000-BASE-W2. Do not use any other power supply. The use of a power supply with apparently similar voltage/current characteristics may damage your terminal.

ATTENTION

L'adaptateur secteur fourni est spécialement conçu pour l'ingenico AXIUM DX8000-BASE-W2. N'utilisez aucun autre bloc d'alimentation. L'utilisation d'une alimentation avec des caractéristiques de tension / courant apparemment similaires peut endommager votre terminal.

10. Standard

FCC WARNING

This device complies with part 15 of the FCC Rules. Operation is subject to the following two conditions:

- (1) This device may not cause harmful interference, and
- (2) this device must accept any interference received, including interference that may cause undesired operation.

Any Changes or modifications not expressly approved by the party responsible for compliance could void the user's authority to operate the equipment

The antennas used for this transmitter must be co-located or operating in conjunction with any other antenna or transmitter.

Note: This equipment has been tested and found to comply with the limits for a Class B digital device, pursuant to part 15 of the FCC Rules. These limits are designed to provide reasonable protection against harmful interference in a residential installation. This equipment generates, uses and can radiate radio frequency energy and, if not installed and used in accordance with the instructions, may cause harmful interference to radio communications. However, there is no guarantee that interference will not occur in a particular installation. If this equipment does cause harmful interference to radio or television reception, which can be determined by turning the equipment off and on, the user is encouraged to try to correct the interference by one or more of the following measures:

- Reorient or relocate the receiving antenna.
- Increase the separation between the equipment and receiver.
- Connect the equipment into an outlet on a circuit different from that to which the receiver is connected.
- Consult the dealer or an experienced radio/TV technician for help.

RF exposure

The antenna of the product, under normal use condition is at least 20cm away from the body of the user. Warning statement to the user for keeping 20cm separation distance and the prohibition of operating to a person has been printed on the user manual. So, this product under normal use is located on electromagnetic far field between the human body.

ISED/C WARNING

This device complies with Innovation, Science and Economic Development Canada license - exempt RSS standard (s). Operation is subject to the following two conditions:

- (1) this device may not cause interference, and
- (2) this device must accept any interference, including interference that may cause undesired operation of the device.

Le présent appareil est conforme aux CNR d'ISED applicables aux appareils radio exempts de licence. L'exploitation est autorisée aux deux conditions suivantes:

- (1) l'appareil ne doit pas produire de brouillage, et
- (2) l'utilisateur de l'appareil doit accepter tout brouillage radioélectrique subi, même si le brouillage est susceptible d'en compromettre le fonctionnement.

In accordance with the Innovation Regulations, Science and Canada Economic Development, this radio transmitter may operate with an antenna of a type and maximum (or lower) gain approved for the transmitter by Industry Canada. In order to reduce the risk of radio interference to other users, the antenna type and its gain must be chosen so that the equivalent isotropically radiated power (e.i.r.p) does not exceed the intensity required by the antenna establishing a satisfactory communication. Any Changes or modifications not expressly approved by the party responsible for compliance could void the user's authority to operate the equipment.

Exposition aux RF

This equipment complies with ISED radiation exposure limits set forth for an uncontrolled environment. This equipment should be installed and operated with minimum distance 20cm between the radiator & your body. This transmitter must not be co-located or operating in conjunction with any other antenna or transmitter.

Le rayonnement de la classe b respecte ISED fixaient un environnement non contrôlés. Installation et mise en œuvre de ce matériel devrait avec échangeur distance minimale entre 20 cm ton corps. Lanceurs ou ne peuvent pas coexister cette antenne ou capteurs avec d'autres.

Environment (WEEE, Batteries and packaging)

This product is labeled in accordance with European Directives 2012/19/EU concerning Waste Electrical and Electronic Equipment (WEEE) and 2013/56/EU concerning Batteries and Accumulators. Those provisions are requiring producers and manufacturers to become liable for take-back, treatment and recycling upon end of life of equipment and batteries.

THE PRODUCT



The crossed-out waste bin stuck on the product or its accessories means that the product belongs to the family of electrical and electronic equipment, and waste batteries must not be thrown away but collected separately and recycles.

Please contact your retailers for more detailed information about the compliance solution in place for disposing of your old product and used batteries.

Packaging waste must also be collected separately to assure a proper disposal and recycling.

In this way you can participate in the re-use and upgrading of Electrical and Electronic Equipment Waste,

which can have an effect on the environment and human health.

This Document is Copyright © 2020 by ingenico Group. ingenico retains full copyright ownership, rights and protection in all material contained in this document. The recipient can receive this document on the condition that he will keep the document confidential and will not use its contents in any form or by any means, except as agreed beforehand, without the prior written permission of ingenico. Moreover, nobody is authorized to place this document at the disposal of any third party without the prior written permission of ingenico. If such permission is granted, it will be subject to the condition that the recipient ensures that any other recipient of this document, or information contained therein, is held responsible to ingenico for the confidentiality of that information.

Care has been taken to ensure that the content of this document is as accurate as possible. ingenico however declines any responsibility for inaccurate, incomplete or outdated information. The contents of this document may change from time to time without prior notice, and do not create, specify, modify or replace any new or prior contractual obligations agreed upon in writing between ingenico and the user.

ingenico is not responsible for any use of this device, which would be non-consistent with the present document.

All trademarks used in this document remain the property of their rightful owners.

WWW.ingenico.com

28-32, boulevard de Grenelle, 75015 Paris - France / (T)+33(0)1 58 01 80 00 / (F)+33 (0)1 58 01 91 35
Ingenico-SA au capital de 47 656 332 / 317 218 758 RCS Nanterre