

REVISION HISTORY				
REV	AUTHOR	DESCRIPTION	DATE	APPROVED

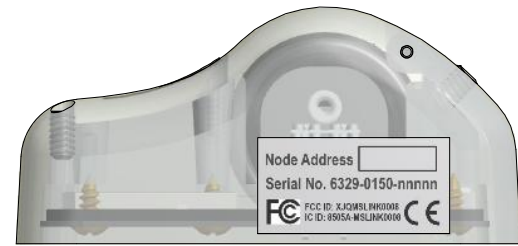
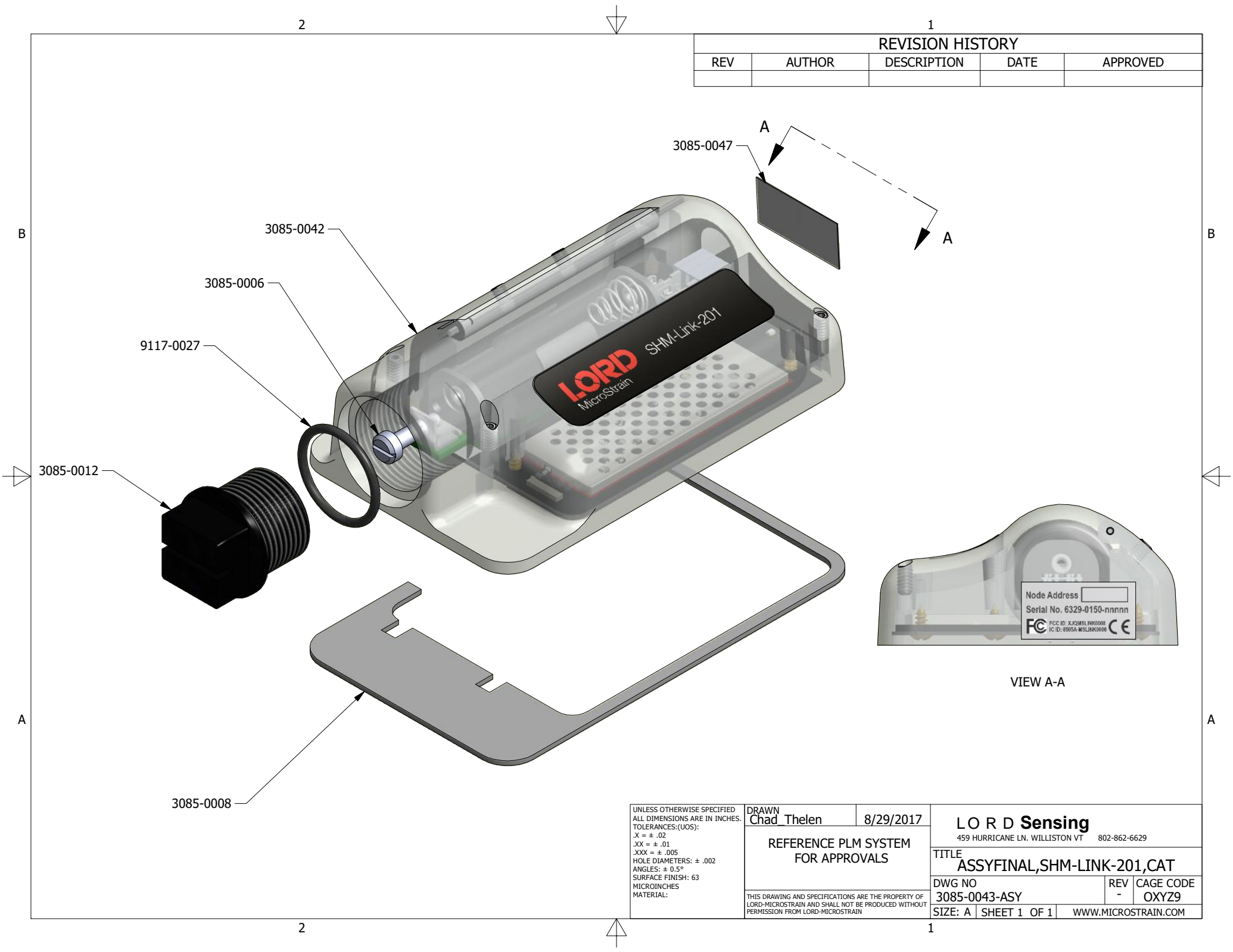

VIEW A-A

UNLESS OTHERWISE SPECIFIED ALL DIMENSIONS ARE IN INCHES. TOLERANCES:(UOS): .X = ± .02 .XX = ± .01 .XXX = ± .005 HOLE DIAMETERS: ± .002 ANGLES: ± 0.5° SURFACE FINISH: 63 MICROINCHES MATERIAL:	DRAWN Chad Thelen	8/29/2017	L O R D Sensing 459 HURRICANE LN. WILLISTON VT 802-862-6629		
	REFERENCE PLM SYSTEM FOR APPROVALS			TITLE ASSYFINAL,SHM-LINK-201,CAT	
	DWG NO 3085-0043-ASY		REV -	CAGE CODE OXYZ9	
	THIS DRAWING AND SPECIFICATIONS ARE THE PROPERTY OF LORD-MICROSTRAIN AND SHALL NOT BE PRODUCED WITHOUT PERMISSION FROM LORD-MICROSTRAIN		SIZE: A SHEET 1 OF 1	WWW.MICROSTRAIN.COM	