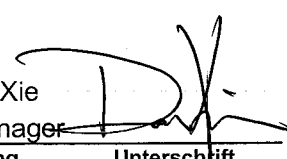

<b>Prüfbericht - Nr.:</b> <b>16030075 001</b>		<b>Seite 1 von 35</b> <i>Page 1 of 35</i>
<i>Test Report No.:</i>		
<b>Auftraggeber:</b> <i>Client:</i>	<b>Desay A&amp;V Science and Technology Co., Ltd.</b> <i>DESAY 3rd Industry Zone, Chenjiang Town, Huizhou City, Guandong, P.R. China</i>	
<b>Gegenstand der Prüfung:</b> <i>Test item:</i>	<b>Blu-ray Disc Player</b>	
<b>Bezeichnung:</b> <i>Identification:</i>	<b>DX-WBRDVD1</b>	<b>Certificate Number:</b> <b>FCC ID: XJGDS0010</b> <i>Certificate Number</i>
<b>Wareneingangs-Nr.:</b> <i>Receipt No.:</i>	<b>173059541</b>	<b>Eingangsdatum:</b> <b>Mar. 15, 2011</b> <i>Date of receipt:</i>
<b>Prüfort:</b> <i>Testing location:</i>	<b>TÜV Rheinland (Guangdong) Ltd. EMC Laboratory</b> <b>Guangzhou Auto Market, Yuan Gang Section of Guangshan Road, Guangzhou 510650,</b> <b>P. R. China</b>	<b>Listed test laboratory according to FCC rules section 2.948 and RSS-Gen, for measuring devices.</b>
<b>Prüfgrundlage:</b> <i>Test specification:</i>	<b>ANSI C63.4: 2003</b> <b>FCC Part 15: 10-1-09 Edition, Subpart C section 15.207, 15.209 and 15.247</b>	
<b>Prüfergebnis:</b> <i>Test Result:</i>	<b>Der Prüfgegenstand entspricht oben genannter Prüfgrundlage(n).</b> <i>The test item passed the test specification(s).</i>	
<b>Prüflaboratorium:</b> <i>Testing Laboratory:</i>	<b>TÜV Rheinland (Guangdong) Ltd.</b>	
<b>geprüft/ tested by:</b>		
<b>kontrolliert/ reviewed by:</b>		
<i>Mar. 24, 2011</i>	Ken Kuang Project Engineer	
<i>Mar. 24, 2011</i>	Liangdong Xie Project Manager	
<b>Datum</b> <i>Date</i>	<b>Name/Stellung</b> <i>Name/Position</i>	<b>Unterschrift</b> <i>Signature</i>
<b>Sonstiges/ Other Aspects:</b>		
<b>Abkürzungen:</b> P(ass) = entspricht Prüfgrundlage F(ail) = entspricht nicht Prüfgrundlage N/A = nicht anwendbar N/T = nicht getestet		
<b>Abbreviations:</b> P(ass) = passed F(ail) = failed N/A = not applicable N/T = not tested		
<b>Dieser Prüfbericht bezieht sich nur auf das o.g. Prüfmuster und darf ohne Genehmigung der Prüfstelle nicht auszugsweise vervielfältigt werden. Dieser Bericht berechtigt nicht zur Verwendung eines Prüfzeichens.</b> <i>This test report relates to the a. m. test sample. Without permission of the test center this test report is not permitted to be duplicated in extracts. This test report does not entitle to carry any safety mark on this or similar products.</i>		

**Prüfbericht - Nr.:**  
*Test Report No.:*

**16030075 001**

**Seite 2 von 35**  
*Page 2 of 35*

## Test Summary

<b>FCC rules</b>	<b>Test items</b>	<b>Result</b>
<b>Part 15 Per Section 15.207(a)</b>	<b>AC Power Conducted Emission</b>	<b>Pass</b>
<b>Part 15 Per Section 15.209(a)</b>	<b>Transmitter Radiated Spurious Emission</b>	<b>Pass</b>
<b>Part 15 Per Section 15.203</b>	<b>Antenna Requirement</b>	<b>Pass</b>
<b>Part 15 Per Section 15.247(b)(3)</b>	<b>Maximum Peak Conducted Output Power</b>	<b>Pass</b>
<b>Part 15 Per Section 15.247(a)(2)</b>	<b>6dB Bandwidth</b>	<b>Pass</b>
<b>Part 15 Per Section 15.247(e)</b>	<b>Power Spectral Density</b>	<b>Pass</b>
<b>Part 15 Per Section 15.247(d)</b>	<b>Out-Of-Band Emission measurement</b>	<b>Pass</b>

## Contents

<b>1</b>	<b>GENERAL REMARKS.....</b>	<b>5</b>
1.1	COMPLEMENTARY MATERIALS.....	5
<b>2</b>	<b>TEST SITES.....</b>	<b>5</b>
2.1	TEST FACILITIES.....	5
2.2	LIST OF TEST AND MEASUREMENT INSTRUMENTS.....	6
2.3	TRACEABILITY.....	6
2.4	CALIBRATION.....	6
2.5	MEASUREMENT UNCERTAINTY.....	7
2.6	LOCATION OF ORIGINAL DATA.....	7
2.7	STATUS OF FACILITY USED FOR TESTING.....	7
<b>3</b>	<b>GENERAL PRODUCT INFORMATION.....</b>	<b>7</b>
3.1	PRODUCT FUNCTION AND INTENDED USE.....	8
3.2	RATINGS AND SYSTEM DETAILS.....	8
3.3	INDEPENDENT OPERATION MODES.....	9
3.4	SUBMITTED DOCUMENTS.....	9
<b>4</b>	<b>TEST SET-UP AND OPERATION MODE.....</b>	<b>10</b>
4.1	PRINCIPLE OF CONFIGURATION SELECTION.....	10
4.2	TEST OPERATION AND TEST SOFTWARE.....	10
4.3	SPECIAL ACCESSORIES AND AUXILIARY EQUIPMENT.....	10
4.4	COUNTERMEASURES TO ACHIEVE EMC COMPLIANCE.....	10
4.5	TEST SET-UP.....	11
<b>5</b>	<b>TEST RESULTS EMISSION.....</b>	<b>13</b>
5.1	CONDUCTED EMISSION ON AC MAINS.....	13
5.2	TRANSMITTER RADIATED SPURIOUS EMISSION.....	15
5.3	ANTENNA REQUIREMENT.....	22
5.4	MAXIMUM PEAK CONDUCTED OUTPUT POWER.....	23
5.5	6DB BANDWIDTH.....	25
5.6	POWER SPECTRAL DENSITY.....	27
5.7	OUT-OF-BAND EMISSION.....	29
<b>6</b>	<b>PHOTOGRAPHS OF THE TEST SET-UP.....</b>	<b>32</b>

**Prüfbericht - Nr.:**  
*Test Report No.:*

**16030075 001**

**Seite 4 von 35**  
*Page 4 of 35*

<b>7</b>	<b>LIST OF TABLES.....</b>	<b>35</b>
<b>8</b>	<b>LIST OF PHOTOGRAPHS.....</b>	<b>35</b>

**Prüfbericht - Nr.:**  
*Test Report No.:*

**16030075 001**

**Seite 5 von 35**  
*Page 5 of 35*

## **1 General Remarks**

### **1.1 Complementary Materials**

All attachments are integral parts of this test report. This applies especially to the following appendix:

Appendix 1: Test result

## **2 Test Sites**

### **2.1 Test Facilities**

**TÜV Rheinland (Guangdong) Ltd. EMC Laboratory**

Guangzhou Auto Market, Yuan Gang Section of Guangshan Road  
Guangzhou 510650

P. R. China

## 2.2 List of Test and Measurement Instruments

**Table 1: List of Test and Measurement Equipment**

Kind of Equipment	Type	Manufacturer	S/N	Calibrated until	Calibrated Interval
EMI Test Receiver	ESU26	Rohde & Schwarz	100209	2012-03-16	1 year
Spectrum Analyzer	FSP30	Rohde & Schwarz	100286	2012-03-16	1 year
Loop Antenna	HFH2-Z2	Rohde & Schwarz	100111	2012-03-16	1 year
Trilog-Broadband Antenna	VULB9168	SCHWARZBECK MESS- ELEKTRONIK	209	2011-08-21	2 years
Double-Ridged Waveguide Horn Antenna	HF906	Rohde & Schwarz	100385	2011-08-24	2 years
Pre-amplifier	AFS42-00101800- 25-S-42	MITEQ	1101599	2013-08-11	2 years
Band Reject Filter	BRM50702	Micro-Tronics	023	2012-03-16	2 years
Standard Gain Horn Antenna	3160-09	EMCO	21642	2014-06-26	5 years
Pre-amplifier	AFS33-18002650- 30-8P-44	MITEQ	1108282	2013-03-16	2 years
3m Anechoic Chamber	N/A	Albatross Project GmbH	N/A	2013-07-17	3 year

## 2.3 Traceability

All measurement equipment calibrations are traceable to NIST or where calibration is performed outside the United States, to equivalent nationally recognized standards organizations.

## 2.4 Calibration

Equipment requiring calibration is calibrated periodically by the manufacturer or according to manufacturer's specifications. Additionally all equipment is verified for proper performance on a regular basis using in house standards or comparisons.

**Prüfbericht - Nr.:**  
*Test Report No.:*

**16030075 001**

**Seite 7 von 35**  
*Page 7 of 35*

## **2.5 Measurement Uncertainty**

Uncertainty for conducted emissions measurements is  $\pm 2.68\text{dB}$ .

Uncertainty for radiated emissions measurements is  $\pm 4.94\text{dB}$  (30MHz-1GHz),  $\pm 4.88\text{dB}$  (>1GHz).

The reported expanded uncertainty is based on a standard uncertainty multiply by a coverage factor  $k=2$ , providing a level of confidence of approximately 95%.

## **2.6 Location of original data**

The original copies of test data taken during actual testing were attached at Appendix 1 of this report and delivered to the applicant. A copy has been retained in the TÜV Rheinland (Guangdong) file for certification follow-up purposes.

## **2.7 Status of facility used for testing**

TÜV Rheinland (Guangdong) Ltd. EMC Laboratory; Guangzhou Auto Market, Yuan Gang Section of Guangshan Road, Guangzhou 510650, P. R. China is listed on the US Federal Communications Commission list of facilities approved to perform measurements, the register no. 833845

TÜV Rheinland (Guangdong) Ltd. EMC Laboratory; Guangzhou Auto Market, Yuan Gang Section of Guangshan Road, Guangzhou 510650, P. R. China is listed on Certification and Engineering Bureau of Canada, whose file number is IC 2932C.

## **3 General Product Information**

The submitted sample DX-WBRDVD1 is a Blu-ray Disc player with wireless module.

**Prüfbericht - Nr.:**  
*Test Report No.:*

**16030075 001**

**Seite 8 von 35**  
*Page 8 of 35*

### 3.1 Product Function and Intended Use

Following function is provided:

1. DVD playback.
2. Wired / wireless network connection.

Refer to user manual for more information.

### 3.2 Ratings and System Details

Frequency range	:	IEEE 802.11b/g /n(HT20): 2412MHz---2462MHz IEEE 802.11n (HT40): 2422MHz-----2452MHz
Number of employed channels	:	IEEE 802.11b/g ,802.11n (HT20): 11 IEEE802.11n (HT40): 7
Modulation Type	:	DSSS, OFDM
Mode of RF Operation (Simplex/ Duplex)	:	Duplex
Type of antenna	:	Non-detachable printed antennas (Ant#0 & Ant#1)
Antenna Gain	:	1dBi
Power supply	:	AC 100V-240V 50/60Hz
Ports	:	AC mains Ethernet HDMI USB Audio/Video output Coaxial output
Protection Class	:	II

The above information was declared by client. Refer to the Technical Documentation for further information



**Prüfbericht - Nr.:**  
*Test Report No.:*

**16030075 001**

**Seite 9 von 35**  
*Page 9 of 35*

### **3.3 Independent Operation Modes**

Off

On (802.11b / 802.11g / 802.11n HT20 / 802.11n HT40)

The basic operation modes for wireless connection:  
Transmitting and receiving

For further information refer to User Manual

### **3.4 Submitted Documents**

Operation Description  
Block Diagram  
Schematics  
FCC label and its location  
User Manual  
Internal Photos  
External Photos  
Application form

## **4 Test Set-up and Operation Mode**

### **4.1 Principle of Configuration Selection**

**Emission:** The equipment under test (EUT) was configured to measure its highest possible radiation level. The test modes were adapted accordingly in reference to the instructions for use.

### **4.2 Test Operation and Test Software**

Refer to test set-up in chapter 5.

### **4.3 Special Accessories and Auxiliary Equipment**

The product has been tested together with the following auxiliary equipment.

1. Laptop PC:

Manufacturer: IBM  
Model Number: X60  
Serial Number: L3-CG041

2. Test software: wl commands provided by client.

Note: During the test, the RF output power was set to the level declared by client, via wl commands.

### **4.4 Countermeasures to achieve EMC Compliance**

The test sample, which has been tested, contained the noise suppression parts as described in the technical document. No additional measures were employed to achieve compliance.

## 4.5 Test set-up

### Diagram 1 of Configuration for Testing Radiated Emission below 30MHz

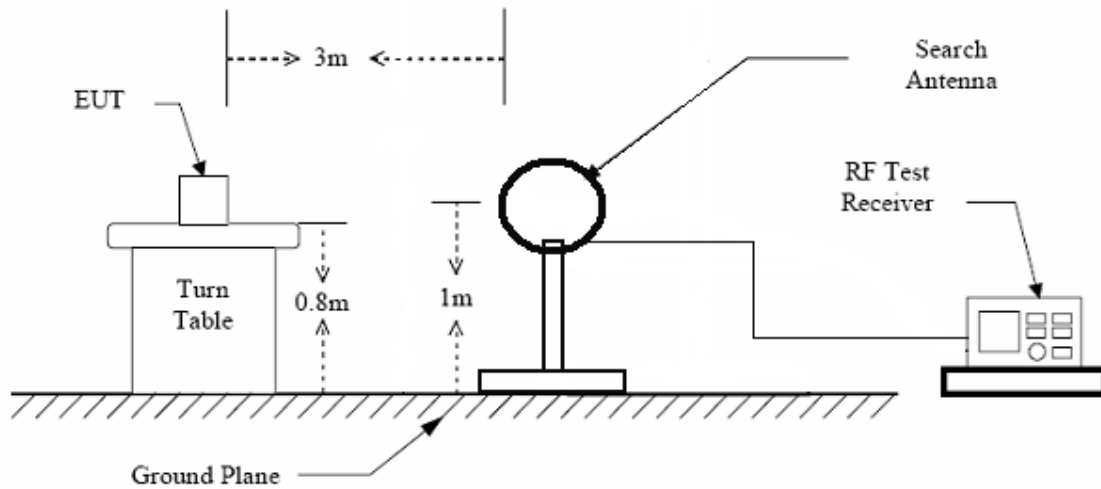

### Diagram 2 of Configuration for Testing Radiated Emission from 30MHz to 1 GHz

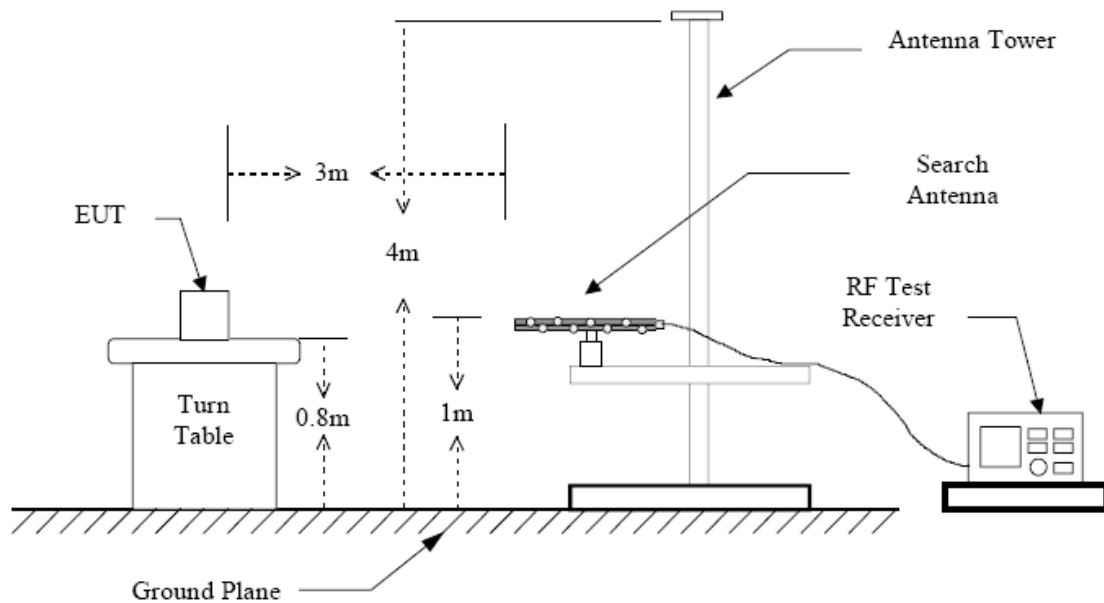

**Diagram 3 of Configuration for Testing Radiated Emission above 1 GHz**

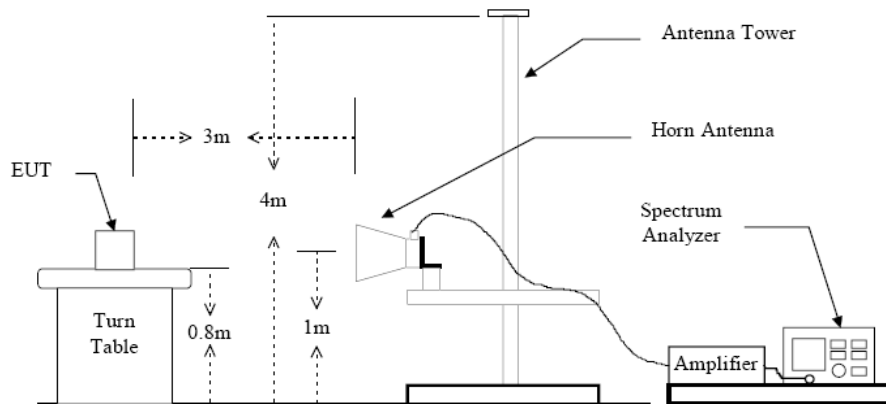

**Diagram 4 of Measurement Equipment Configuration for Testing Conducted Emission**

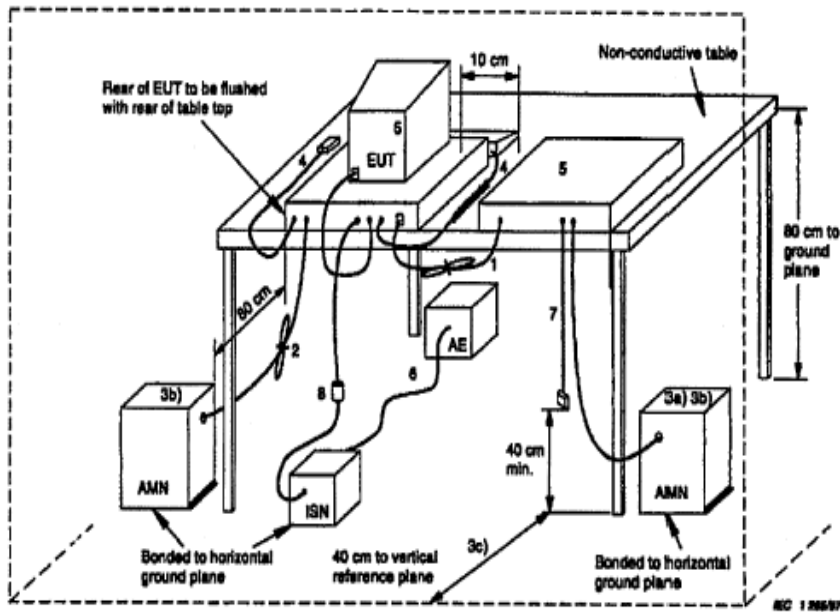

**Diagram 5 of Configuration for Testing other test items**

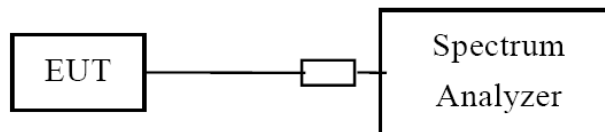

**Prüfbericht - Nr.:**  
*Test Report No.:*

**16030075 001**

**Seite 13 von 35**  
*Page 13 of 35*

## **5 Test Results EMISSION**

### **5.1 Conducted Emission on AC mains**

**RESULT:**

**Pass**

Date of testing	:	Mar. 17, 2011
Test specification	:	FCC Part 15 Per Section 15.207(a)
Limits	:	FCC Part 15 Per Section 15.207(a)
Test procedure	:	Procedure specified in ANSI C63.4 was followed
Deviations from Standard Test procedures	:	None
Kind of test site	:	Shielded room
Operation mode	:	Normal operation
Power supply	:	AC 120V 60Hz
Temperature	:	20°C
Humidity	:	45%

**Test procedure:**

1. Place the EUT as specified in ANSI C63.4 Clause 7.2.1
2. Plug the LISN to a correct power source.
3. Connect the LISN to the power source.
4. Connect the EUT to LISN and choose N or L1 on the LISN.
5. Connect ESCS30 and LISN via a 50-ohm coaxial cable and a pulse limiter then begin exploratory measurement as specified in ANSI C63.4 Clause 7.2.3
6. Make final measurement as specified in ANSI C63.4 Clause 7.2.4

**Prüfbericht - Nr.:**  
*Test Report No.:*

**16030075 001**

**Seite 14 von 35**  
*Page 14 of 35*

**Table 2: Disturbance Voltage on AC Mains**

Frequency [MHz]	Line L/N	QP [dB $\mu$ V]	AV [dB $\mu$ V]	Quasi Peak Limit [dB $\mu$ V]	Average Limit [dB $\mu$ V]
0.159	L	54.6	--	65.5	55.5
0.501	L	24.7	--	56.0	46.0
3.358	N	36.9	--	56.0	46.0
3.390	L	36.2	--	56.0	46.0
3.453	L	31.4	--	56.0	46.0
21.322	L	33.7	--	60.0	50.0
*)					

\*) Measurement is made from 150 kHz to 30 MHz. Disturbances other than those mentioned above are small or not detectable. Refer to appendix 1 for the test plot.

If the result of the measurement with the Quasi Peak detector is below the Average limit, the measurement with Average Detector may be omitted.

## 5.2 Transmitter Radiated Spurious Emission

**RESULT:**

**Pass**

Date of testing	:	Mar. 21, 2011 to Mar. 23, 2011
Test specification	:	FCC Part 15 Per Section 15.209(a)
Limits	:	FCC Part 15 Per Section 15.209(a)
Test procedure	:	Procedure specified in ANSI C63.4 was followed
Deviations from Standard Test procedures	:	None
Kind of test site	:	3m Semi-anechoic chamber
Operation mode	:	Below 1GHz: normal operation Above 1GHz: Transmitting at low, middle and high channel ( 802.11b / 802.11g / 802.11n HT20 / 802.11n HT40)
Power supply	:	AC 120V 60Hz
Temperature	:	23°C
Humidity	:	50%

**Test procedure:**

1. The EUT was placed on the top of a rotatable table 0.8 meters above the ground with 3-orthogonal direction and be kept close enough to the receiving antenna. The table was rotated 360 degrees to determine the suspected emission frequency and the position of the worst radiation case with both horizontal and vertical antenna polarization.
2. The EUT was then set 3 meters away from the receiving antenna, which was mounted on a variable-height antenna tower.
3. For each suspected emission frequency recorded in step 1, the EUT was arranged to its worst case and:  
for tests below 30MHz the loop antenna is positioned with its plane vertical and the center of it is 1m above the ground. During the tests it is rotated about its vertical axis for maximum response at each azimuth about the EUT;  
for tests above 30MHz the antenna was tuned to heights from 1 meter to 4 meters and the rotatable table was turned from 0 degrees to 360 degrees to read the maximum emission.
4. The RBW and VBW of the test receiver were 120 kHz and 120 kHz for Quasi-peak detection at frequency below 1GHz.  
The RBW and VBW of the test receiver were 1MHz and 3MHz for Peak detection at frequency above 1GHz.  
For Average measurement at frequency above 1GHz. The resolution bandwidth of the test receiver was 1MHz, video bandwidth is 10Hz. If the peak value was below the AV limit, AV measurement was skipped.

**Prüfbericht - Nr.:**  
*Test Report No.:*

**16030075 001**

**Seite 16 von 35**  
*Page 16 of 35*

**Table 3: Radiated Emission (802.11b Transmitting at 2412MHz)**

Frequency	QP	AV	PK	Polarity	Limit		
					QP	AV	PK
[MHz]	[dB $\mu$ V/m]			(H/V)	[dB $\mu$ V/m]		
1486.62	N/A	--	42.5	H	N/A	54	74
1658.75	N/A	--	42.1	H	N/A	54	74
4822.87	N/A	--	46.5	H	N/A	54	74
7234.75	N/A	--	52.5	H	N/A	54	74
1488.75	N/A	--	52.3	V	N/A	54	74
1658.75	N/A	--	52.2	V	N/A	54	74
4822.87	N/A	--	51.1	V	N/A	54	74
7234.75	N/A	--	50.1	V	N/A	54	74
*)---							

**Table 4: Radiated Emission (802.11b Transmitting at 2437MHz)**

Frequency	QP	AV	PK	Polarity	Limit		
					QP	AV	PK
[MHz]	[dB $\mu$ V/m]			(H/V)	[dB $\mu$ V/m]		
1486.62	N/A	--	46.2	H	N/A	54	74
4873.87	N/A	52.3	57.5	H	N/A	54	74
7311.25	N/A	48.8	55.4	H	N/A	54	74
1660.87	N/A	--	52.5	V	N/A	54	74
1996.62	N/A	44.5	57.3	V	N/A	54	74
4873.87	N/A	--	53.0	V	N/A	54	74
7311.25	N/A	46.2	53.5	V	N/A	54	74
*)---							



**Prüfbericht - Nr.:**  
*Test Report No.:*

**16030075 001**

**Seite 17 von 35**  
*Page 17 of 35*

**Table 5: Radiated Emission (802.11b Transmitting at 2462MHz)**

Frequency	QP	AV	PK	Polarity	Limit		
					QP	AV	PK
[MHz]	[dB $\mu$ V/m]			(H/V)	[dB $\mu$ V/m]		
1996.62	N/A	--	50.1	H	N/A	54	74
4922.75	N/A	--	49.4	H	N/A	54	74
7385.62	N/A	--	50.6	H	N/A	54	74
1486.62	N/A	--	47.9	V	N/A	54	74
1658.75	N/A	--	46.6	V	N/A	54	74
1994.50	N/A	--	51.2	V	N/A	54	74
4924.87	N/A	--	50.7	V	N/A	54	74
7383.50	N/A	--	53.2	V	N/A	54	74
*)---							

**Table 6: Radiated Emission (802.11g Transmitting at 2412MHz)**

Frequency	QP	AV	PK	Polarity	Limit		
					QP	AV	PK
[MHz]	[dB $\mu$ V/m]			(H/V)	[dB $\mu$ V/m]		
4818.62	N/A	38.2	63.8	H	N/A	54	74
7236.87	N/A	46.7	72.2	H	N/A	54	74
9642.37	N/A	34.8	66.1	H	N/A	54	74
1665.12	N/A	36.1	54.1	V	N/A	54	74
1994.50	N/A	--	48.0	V	N/A	54	74
4814.37	N/A	--	45.3	V	N/A	54	74
*)---							

**Prüfbericht - Nr.:**  
*Test Report No.:*

**16030075 001**

**Seite 18 von 35**  
*Page 18 of 35*

**Table 7: Radiated Emission (802.11g Transmitting at 2437MHz)**

Frequency	QP	AV	PK	Polarity	Limit		
					QP	AV	PK
[MHz]	[dB $\mu$ V/m]			(H/V)	[dB $\mu$ V/m]		
1486.62	N/A	39.1	57.5	H	N/A	54	74
1983.87	N/A	--	46.1	H	N/A	54	74
4876.00	N/A	39.0	57.6	H	N/A	54	74
7309.12	N/A	43.9	70.5	H	N/A	54	74
1665.12	N/A	34.1	53.7	V	N/A	54	74
4873.87	N/A	34.3	52.5	V	N/A	54	74
7317.62	N/A	31.7	52.9	V	N/A	54	74
*)---							

**Table 8: Radiated Emission (802.11g Transmitting at 2462MHz)**

Frequency	QP	AV	PK	Polarity	Limit		
					QP	AV	PK
[MHz]	[dB $\mu$ V/m]			(H/V)	[dB $\mu$ V/m]		
1990.25	N/A	--	50.8	H	N/A	54	74
4924.87	N/A	40.3	56.9	H	N/A	54	74
7385.62	N/A	43.4	68.1	H	N/A	54	74
1998.75	N/A	38.4	55.3	V	N/A	54	74
2659.62	N/A	--	51.3	V	N/A	54	74
4918.50	N/A	--	45.2	V	N/A	54	74
7375.00	N/A	38.1	54.6	V	N/A	54	74
*)---							

**Prüfbericht - Nr.:**  
*Test Report No.:*

**16030075 001**

**Seite 19 von 35**  
*Page 19 of 35*

**Table 9: Radiated Emission (802.11n HT20, Transmitting at 2412MHz)**

Frequency	QP	AV	PK	Polarity	Limit		
					QP	AV	PK
[MHz]	[dB $\mu$ V/m]			(H/V)	[dB $\mu$ V/m]		
1486.62	N/A	--	51.3	H	N/A	54	74
1996.62	N/A	--	51.7	H	N/A	54	74
4827.12	N/A	37.0	62.7	H	N/A	54	74
7236.87	N/A	42.9	70.4	H	N/A	54	74
1656.62	N/A	--	52.1	V	N/A	54	74
1994.50	N/A	42.2	58.9	V	N/A	54	74
4827.12	N/A	39.4	58.8	V	N/A	54	74
7243.25	N/A	38.0	65.3	V	N/A	54	74
*)---							

**Table 10: Radiated Emission (802.11n HT20, Transmitting at 2437MHz)**

Frequency	QP	AV	PK	Polarity	Limit		
					QP	AV	PK
[MHz]	[dB $\mu$ V/m]			(H/V)	[dB $\mu$ V/m]		
1323.00	N/A	--	44.5	H	N/A	54	74
4871.75	N/A	35.5	62.5	H	N/A	54	74
7302.75	N/A	37.8	62.7	H	N/A	54	74
1146.62	N/A	--	46.7	V	N/A	54	74
1992.37	N/A	39.7	55.7	V	N/A	54	74
7302.75	N/A	41.2	66.0	V	N/A	54	74
*)---							

**Prüfbericht - Nr.:**  
*Test Report No.:*

**16030075 001**

**Seite 20 von 35**  
*Page 20 of 35*

**Table 11: Radiated Emission (802. 11n HT20, Transmitting at 2462MHz)**

Frequency	QP	AV	PK	Polarity	Limit		
					QP	AV	PK
[MHz]	[dB $\mu$ V/m]			(H/V)	[dB $\mu$ V/m]		
1123.25	N/A	--	52.1	H	N/A	54	74
1488.75	N/A	--	51.2	H	N/A	54	74
4924.87	N/A	41.3	57.3	H	N/A	54	74
7387.75	N/A	45.9	68.6	H	N/A	54	74
1486.62	N/A	--	51.6	V	N/A	54	74
1663.00	N/A	--	52.8	V	N/A	54	74
4927.00	N/A	--	49.3	V	N/A	54	74
7392.00	N/A	35.4	53.0	V	N/A	54	74
*)---							

**Table 12: Radiated Emission (802. 11n HT40, Transmitting at 2422MHz)**

Frequency	QP	AV	PK	Polarity	Limit		
					QP	AV	PK
[MHz]	[dB $\mu$ V/m]			(H/V)	[dB $\mu$ V/m]		
1992.37	N/A	37.9	54.4	H	N/A	54	74
4848.37	N/A	--	48.3	H	N/A	54	74
7287.87	N/A	36.7	56.9	H	N/A	54	74
1486.62	N/A	--	50.1	V	N/A	54	74
4839.87	N/A	39.4	55.1	V	N/A	54	74
7275.12	N/A	43.2	65.2	V	N/A	54	74
*)---							

**Prüfbericht - Nr.:**  
*Test Report No.:*

**16030075 001**

**Seite 21 von 35**  
*Page 21 of 35*

**Table 13: Radiated Emission (802.11n HT40, Transmitting at 2437MHz)**

Frequency	QP	AV	PK	Polarity	Limit		
					QP	AV	PK
[MHz]	[dB $\mu$ V/m]			(H/V)	[dB $\mu$ V/m]		
1488.75	N/A	--	47.2	H	N/A	54	74
4867.50	N/A	--	45.7	H	N/A	54	74
7304.87	N/A	40.6	58.4	H	N/A	54	74
1663.00	N/A	35.0	56.3	V	N/A	54	74
1998.75	N/A	40.1	56.7	V	N/A	54	74
4880.25	N/A	38.4	55.2	V	N/A	54	74
7315.50	N/A	44.5	65.5	V	N/A	54	74
*)---							

**Table 14: Radiated Emission (802.11n HT40, Transmitting at 2452MHz)**

Frequency	QP	AV	PK	Polarity	Limit		
					QP	AV	PK
[MHz]	[dB $\mu$ V/m]			(H/V)	[dB $\mu$ V/m]		
1486.62	N/A	--	52.1	H	N/A	54	74
4914.25	N/A	39.9	56.2	H	N/A	54	74
7355.87	N/A	40.3	58.1	H	N/A	54	74
1486.62	N/A	--	50.7	V	N/A	54	74
1998.75	N/A	38.3	56.8	V	N/A	54	74
7302.75	N/A	--	43.4	V	N/A	54	74
*)---							

\*) Measurement is made from 20MHz to 26 GHz. Disturbances other than those mentioned above are small or not detectable. Refer to appendix 1 for the test plot of measurement from 30MHz to 1GHz.

**Prüfbericht - Nr.:**  
*Test Report No.:*

**16030075 001**

**Seite 22 von 35**  
*Page 22 of 35*

### **5.3 Antenna requirement**

**RESULT:**

**Pass**

Date of testing : ---  
Test specification : FCC Part 15 Per Section 15.203  
FCC Part 15 Per Section 15.247(b)

For intentional device, according to 15.203, and intentional radiator shall be designed to ensure that no antenna other than that furnished by the responsible party shall be used with the device.

And according to 15.247(b), if transmitting antennas of directional gain greater than 6dBi are used, the power shall be reduced by amount in dB than the directional gain of the antenna exceeds of 6dBi.

As the antenna is permanently printed on RF Board, there is no possibility of replacement.

Since the max gain of the antenna is 1dBi, it is no need to reduce the peak output power limit.

## 5.4 Maximum Peak Conducted Output Power

**RESULT:**

**Pass**

Date of testing : Mar. 23, 2011  
 Test specification : FCC Part 15 Per Section 15.247(b)(3)  
 Limits : FCC Part 15 Per Section 15.247(b)(3)  
 For systems using digital modulation in the 902-928 MHz, 2400-2483.5 MHz, and 5725-5850 MHz, the max. peak conducted output power shall not exceed 1 Watt.  
 Deviations from Standard Test procedures : None  
 Test procedure : Procedure specified in ANSI C63.4 was followed  
 Kind of test site : Shielded room  
 Operation mode : Transmitting at low, middle and high channel  
 ( 802.11b / 802.11g / 802.11n HT20 / 802.11n HT40)  
 Power supply : AC 120V 60Hz  
 Temperature : 22°C  
 Humidity : 50%

**Test procedure:**

1. Connect the antenna output of the EUT to the power meter by a low lost cable.
2. Set the EUT to proper test mode with relative test software and hardware.
3. Read the power from power meter and add the cable loss correction.

**Table 15: Peak Conducted Power (802.11b)**

Channel	Frequency(MHz)	Power Reading (dBm)	Cable Loss (dB)	Output Power		Limit (mW)
				(dBm)	(mW)	
Low	2412	8.15	0.4	8.55	7.16	<1000
Mid	2437	8.15	0.4	8.55	7.16	<1000
High	2462	8.24	0.4	8.64	7.31	<1000

**Table 16: Peak Conducted Power (802.11g)**

Channel	Frequency(MHz)	Power Reading (dBm)	Cable Loss (dB)	Output Power		Limit (mW)
				(dBm)	(mW)	
Low	2412	11.82	0.4	12.22	16.67	<1000
Mid	2437	11.80	0.4	12.20	16.60	<1000
High	2462	11.91	0.4	12.31	17.02	<1000

**Prüfbericht - Nr.:**  
*Test Report No.:*

**16030075 001**

**Seite 24 von 35**  
*Page 24 of 35*

**Table 17: Peak Conducted Power (802.11n HT20)**

Channel	Frequency(MHz)	Power Reading(dBm)		Cable Loss (dB)	Output Power of Ant#0		Output Power of Ant#1		Total output power (mW)	Limit (mW)
		Ant#0	Ant#1		(dBm)	(mW)	(dBm)	(mW)		
Low	2412	11.82	11.74	0.4	12.22	16.67	12.14	16.37	33.04	<1000
Mid	2437	12.02	12.12	0.4	12.42	17.46	12.52	17.86	35.32	<1000
High	2462	12.10	11.97	0.4	12.50	17.78	12.37	17.26	35.04	<1000

**Table 18: Peak Conducted Power (802.11n HT40)**

Channel	Frequency(MHz)	Power Reading(dBm)		Cable Loss (dB)	Output Power of Ant#0		Output Power of Ant#1		Total output power (mW)	Limit (mW)
		Ant#0	Ant#1		(dBm)	(mW)	(dBm)	(mW)		
Low	2422	11.82	11.91	0.4	12.22	16.67	12.31	17.02	33.69	<1000
Mid	2437	11.85	11.92	0.4	12.25	16.79	12.32	17.06	33.85	<1000
High	2452	12.52	12.21	0.4	12.92	19.59	12.61	18.24	37.83	<1000



**Prüfbericht - Nr.:**  
*Test Report No.:*

**16030075 001**

**Seite 25 von 35**  
*Page 25 of 35*

## 5.5 6dB Bandwidth

**RESULT:**

**Pass**

Date of testing : Mar. 14, 2011  
 Test specification : FCC Part 15 Per Section 15.247(a)(2)  
 Limits : FCC Part 15 Per Section 15.247(a)(2)  
 The minimum 6 dB bandwidth shall be at least 500 kHz.  
 Deviations from Standard Test procedures : None  
 Test procedure : Procedure specified in ANSI C63.4 was followed  
 Operation mode : Transmitting at low, middle and high channel  
 ( 802.11b / 802.11g / 802.11n HT20 / 802.11n HT40)  
 Kind of test site : Shielded room  
 Power supply : AC 120V 60Hz  
 Temperature : 23°C  
 Humidity : 50%

**Test procedure:**

1. Connect the antenna output of the EUT to the spectrum analyzer by a low lost cable.
2. Set the EUT to proper test mode with relative test software and hardware.
3. Spectrum analyzer setting: Centered Frequency= measured channel, RBW=100kHz, VBW=300kHz.
4. Mark the peak power frequency point and the -6dB upper and lower frequency points.
5. Read the frequency delta value between the -6dB upper and lower frequency points.
6. Repeat step 2 to 5 until all the channels required are finished.

**Table 19: 6dB Bandwidth (802.11b)**

Channel	Frequency (MHz)	Test Result (MHz)	Limit (kHz)
Low	2412	9.0	>500
Mid	2437	9.0	>500
High	2462	9.0	>500

**Prüfbericht - Nr.:**  
*Test Report No.:*

**16030075 001**

**Seite 26 von 35**  
*Page 26 of 35*

**Table 20: 6dB Bandwidth (802.11g)**

Channel	Frequency (MHz)	Test Result (MHz)	Limit (kHz)
Low	2412	15.4	>500
Mid	2437	15.4	>500
High	2462	15.4	>500

**Table 21: 6dB Bandwidth (802.11n HT20)**

Channel	Frequency (MHz)	Test Result (MHz)	Limit (kHz)
Low	2412	17.3	>500
Mid	2437	16.5	>500
High	2462	16.3	>500

**Table 22: 6dB Bandwidth (802.11n HT40)**

Channel	Frequency (MHz)	Test Result (MHz)	Limit (kHz)
Low	2422	35.7	>500
Mid	2437	36.0	>500
High	2452	35.7	>500

Please refer to Appendix 1 for measurement data.

**Prüfbericht - Nr.:**  
*Test Report No.:*

**16030075 001**

**Seite 27 von 35**  
*Page 27 of 35*

## 5.6 Power Spectral Density

**RESULT:**

**Pass**

Date of testing	:	Mar. 15, 2011
Test specification	:	FCC Part 15 Per Section 15.247(e)
Limits	:	FCC Part 15 Per Section 15.247(e) For digitally modulated systems, the power spectral density conducted from the intentional radiator to the antenna shall not be greater than 8 dBm in any 3 kHz band during any time interval of continuous transmission
Deviations from Standard Test procedures	:	None
Test procedure	:	Procedure specified in ANSI C63.4 was followed
Kind of test site	:	Shielded room
Operation mode	:	Transmitting at low, middle and high channel ( 802.11b / 802.11g / 802.11n HT20 / 802.11n HT40)
Power supply	:	AC 120V 60Hz
Temperature	:	23°C
Humidity	:	50%

**Test procedure:**

1. Connect the antenna output of the EUT to the spectrum analyzer by a low loss cable.
2. Set the EUT to proper test mode with relative test software and hardware.
3. Spectrum analyzer setting: Centered Frequency= measured channel, RBW= 3kHz, VBW=10kHz..  
Span = 600kHz, Sweep Time = 200s.
4. Mark the max. peak point.
5. Repeat step 2 to 4 until all the channels required are finished.

**Prüfbericht - Nr.:**  
*Test Report No.:*

**16030075 001**

**Seite 28 von 35**  
*Page 28 of 35*

**Table 23: Power spectral density (802.11b)**

Channel	Frequency (MHz)	Test Result (dBm)	Limit (dBm)
Low	2412.000	-11.12	<8
Mid	2437.000	-10.84	<8
High	2462.000	-11.59	<8

**Table 24: Power spectral density (802.11g)**

Channel	Frequency (MHz)	Test Result (dBm)	Limit (dBm)
Low	2412.000	-10.71	<8
Mid	2437.000	-10.64	<8
High	2462.000	-10.79	<8

**Table 25: Power spectral density (802.11n HT20)**

Channel	Frequency (MHz)	Test Result (dBm)	Limit (dBm)
Low	2412.000	-9.54	<8
Mid	2437.000	-10.02	<8
High	2462.000	-9.54	<8

**Table 26: Power spectral density (802.11n HT40)**

Channel	Frequency (MHz)	Test Result (dBm)	Limit (dBm)
Low	2422.000	-24.27	<8
Mid	2437.000	-24.31	<8
High	2452.000	-24.09	<8

Please refer to Appendix 1 for measurement data.

**Prüfbericht - Nr.:**  
*Test Report No.:*

**16030075 001**

**Seite 29 von 35**  
*Page 29 of 35*

## 5.7 Out-of-Band Emission

### RESULT:

**Pass**

Date of testing : Mar. 15, 2011 & Mar. 22, 2011  
Test specification : FCC Part 15 Per Section 15.247(d)  
Limits : FCC Part 15 Per Section 15.247(d)  
In any 100kHz bandwidth outside the frequency band in which the spread spectrum or digitally modulated intentional radiator is operating, the radio frequency power that is produced by the intentional radiator shall be at least 20dB below that in the 100kHz bandwidth within the band that contains the highest level of the desired power, based on either an RF conducted or a radiated measurement.

In addition:

FCC Part 15 - radiated emission which fall in the restricted bands, as defined in Section 15.205(a), must also comply with the radiated emission limits specified in section 15.209(a).

Deviations from Standard Test procedures : None  
Test Procedure : Procedure specified in ANSI C63.4 was followed  
Kind of test site : Shielded room  
Operation mode : Transmitting at low, middle and high channel ( 802.11b / 802.11g / 802.11n HT20 / 802.11n HT40)  
Power supply : AC 120V 60Hz  
Temperature : 23°C  
Humidity : 50%

### Test procedure:

1. Connect the antenna port of the EUT to the spectrum analyzer by a low loss cable.
2. Set the EUT to proper test mode with relative test software and hardware.
3. Spectrum analyzer setting: RBW = 100 kHz, VBW ≥ RBW.
4. Set proper frequency span respectively for out-of-band emission measurement of the band edge and the whole range (up to 10 times of the carrier frequency.)
5. Set the trace mode to Max Hold and mark the peak reading of any spurious emission recorded.
6. The band edge radiated emission was measured according to the procedure in clause 5.2 of this report.

**Prüfbericht - Nr.:**  
*Test Report No.:*

**16030075 001**

**Seite 30 von 35**  
*Page 30 of 35*

**Table 27: Out-Of-Band Emission measurement (conducted)**

<b>Emission (Max reading among Channel low, mid and high)</b>	<b>Attenuation</b>	<b>Limit (dB)</b>
30MHz to 25GHz	All emission in this 100kHz bandwidth are attenuated more than 20dB from the carrier	$\Delta \geq 20$

**Table 28: Band Edges Emission in the Restricted Bands 2483.5-2500MHz and 2310-2390MHz (802.11b)**

<b>Restricted band</b>	<b>Frequency [GHz]</b>	<b>PK [dB<math>\mu</math>V/m]</b>	<b>AV [dB<math>\mu</math>V/m]</b>	<b>Polarity (H/V)</b>	<b>PK limit [dB<math>\mu</math>V/m]</b>	<b>AV limit [dB<math>\mu</math>V/m]</b>
Low band	2.390	54.8	46.4	H	74	54
Low band	2.390	55.6	47.1	V	74	54
High band	2.484	55.7	48.2	H	74	54
High band	2.484	54.1	48.2	V	74	54
<b>Remark:--</b>						

**Table 29: Band Edges Emission in the Restricted Bands 2483.5-2500MHz and 2310-2390MHz (802.11g)**

<b>Restricted band</b>	<b>Frequency [GHz]</b>	<b>PK [dB<math>\mu</math>V/m]</b>	<b>AV [dB<math>\mu</math>V/m]</b>	<b>Polarity (H/V)</b>	<b>PK limit [dB<math>\mu</math>V/m]</b>	<b>AV limit [dB<math>\mu</math>V/m]</b>
Low band	2.390	55.4	46.7	H	74	54
Low band	2.390	55.7	47.2	V	74	54
High band	2.484	55.0	49.5	H	74	54
High band	2.484	55.1	48.4	V	74	54
<b>Remark:--</b>						

**Prüfbericht - Nr.:**  
*Test Report No.:*

**16030075 001**

**Seite 31 von 35**  
*Page 31 of 35*

**Table 30: Band Edges Emission in the Restricted Bands 2483.5-2500MHz and 2310-2390MHz (802.11n HT20)**

Restricted band	Frequency [GHz]	PK [dB $\mu$ V/m]	AV [dB $\mu$ V/m]	Polarity (H/V)	PK limit [dB $\mu$ V/m]	AV limit [dB $\mu$ V/m]
Low band	2.390	56.0	47.2	H	74	54
Low band	2.390	55.1	47.5	V	74	54
High band	2.484	55.5	49.2	H	74	54
High band	2.484	55.5	48.8	V	74	54

**Remark:--**

**Table 31: Band Edges Emission in the Restricted Bands 2483.5-2500MHz and 2310-2390MHz (802.11n HT40)**

Restricted band	Frequency [GHz]	PK [dB $\mu$ V/m]	AV [dB $\mu$ V/m]	Polarity (H/V)	PK limit [dB $\mu$ V/m]	AV limit [dB $\mu$ V/m]
Low band	2.390	55.4	47.9	H	74	54
Low band	2.390	54.9	47.6	V	74	54
High band	2.484	55.0	49.3	H	74	54
High band	2.484	55.0	49.2	V	74	54

**Remark:--**

\* **Note:** Please refer to the Appendix 1 for the plot.  
Disturbances other than those mentioned above are small or not detectable.

## 6 Photographs of the Test Set-Up

**Photograph 1: Set-up for Conducted Emission Measurement**





**Prüfbericht - Nr.:**  
*Test Report No.:*

**16030075 001**

**Seite 33 von 35**  
*Page 33 of 35*

**Photograph 2: Set-up for Radiation Measurement below 1GHz**



**Prüfbericht - Nr.:**  
*Test Report No.:*

**16030075 001**

**Seite 34 von 35**  
*Page 34 of 35*

**Photograph 3: Set-up for Radiation Measurement above 1GHz**

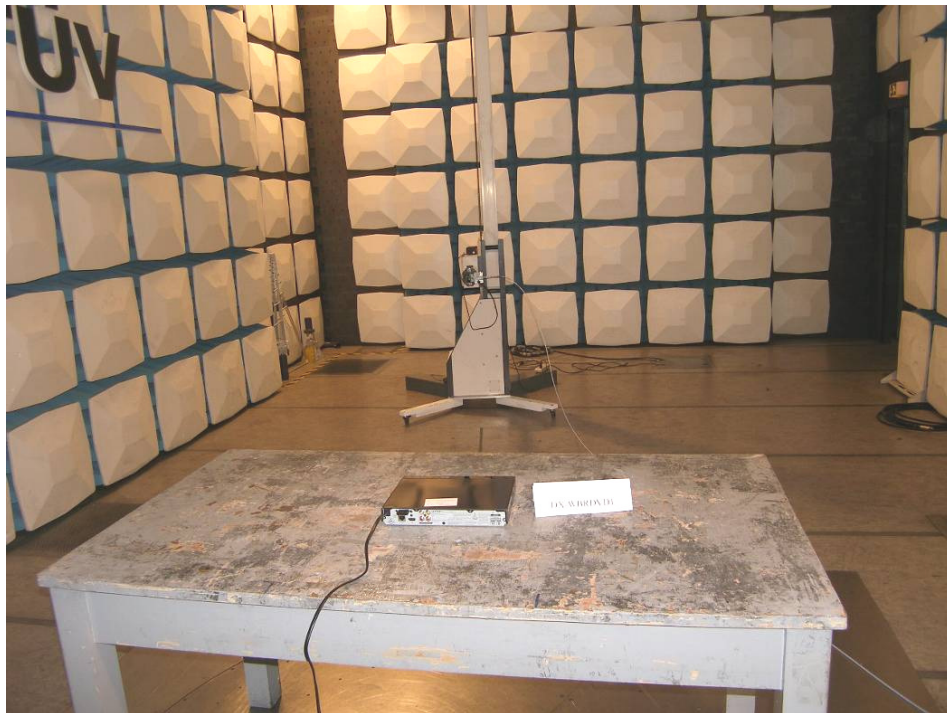

## 7 List of Tables

Table 1: List of Test and Measurement Equipment .....	6
Table 2: Disturbance Voltage on AC Mains .....	14
Table 3: Radiated Emission (802.11b Transmitting at 2412MHz) .....	16
Table 4: Radiated Emission (802.11b Transmitting at 2437MHz) .....	16
Table 5: Radiated Emission (802.11b Transmitting at 2462MHz) .....	17
Table 6: Radiated Emission (802.11g Transmitting at 2412MHz) .....	17
Table 7: Radiated Emission (802.11g Transmitting at 2437MHz) .....	18
Table 8: Radiated Emission (802.11g Transmitting at 2462MHz) .....	18
Table 9: Radiated Emission (802.11n HT20, Transmitting at 2412MHz) .....	19
Table 10: Radiated Emission (802.11n HT20, Transmitting at 2437MHz) .....	19
Table 11: Radiated Emission (802.11n HT20, Transmitting at 2462MHz) .....	20
Table 12: Radiated Emission (802.11n HT40, Transmitting at 2422MHz) .....	20
Table 13: Radiated Emission (802.11n HT40, Transmitting at 2437MHz) .....	21
Table 14: Radiated Emission (802.11n HT40, Transmitting at 2452MHz) .....	21
Table 15: Peak Conducted Power (802.11b) .....	23
Table 16: Peak Conducted Power (802.11g) .....	23
Table 17: Peak Conducted Power (802.11n HT20) .....	24
Table 18: Peak Conducted Power (802.11n HT40) .....	24
Table 19: 6dB Bandwidth (802.11b) .....	25
Table 20: 6dB Bandwidth (802.11g) .....	26
Table 21: 6dB Bandwidth (802.11n HT20) .....	26
Table 22: 6dB Bandwidth (802.11n HT40) .....	26
Table 23: Power spectral density (802.11b) .....	28
Table 24: Power spectral density (802.11g) .....	28
Table 25: Power spectral density (802.11n HT20) .....	28
Table 26: Power spectral density (802.11n HT40) .....	28
Table 27: Out-Of-Band Emission measurement (conducted) .....	30
Table 28: Band Edges Emission in the Restricted Bands 2483.5-2500MHz and 2310-2390MHz (802.11b) .....	30
Table 29: Band Edges Emission in the Restricted Bands 2483.5-2500MHz and 2310-2390MHz (802.11g) .....	30
Table 30: Band Edges Emission in the Restricted Bands 2483.5-2500MHz and 2310-2390MHz (802.11n HT20) .....	31
Table 31: Band Edges Emission in the Restricted Bands 2483.5-2500MHz and 2310-2390MHz (802.11n HT40) .....	31

## 8 List of Photographs

Photograph 1: Set-up for Conducted Emission Measurement .....	32
Photograph 2: Set-up for Radiation Measurement below 1GHz .....	33
Photograph 3: Set-up for Radiation Measurement above 1GHz .....	34

**Prüfbericht - Nr.:** 16030075 001  
*Test Report no.*

Seite 1 von 37  
Page 1 of 37

**AC power conducted emission**

TUV Rheinland (Guangdong) Ltd.

EMC Test Service Hotline: +86-20-28391188

**EMC Test Record (EMISSION)**

**Test Information**

Manufacturer: Desay  
Test Item: DVD player  
Identification: DX-WBRDVD1  
Test Standard: FCC Part 15  
Test Detail: Conducted Emission  
Operation Mode: Normal operation  
Climate Condition: 20 °C; 45 %RH; 101 kPa.  
Test Voltage/ Freq.: AC 120 V/ 60 Hz  
Port / Line: AC Mains(L1+N)  
Receipt No.: 173059541  
Report No.: 16030075 001  
Result: Pass  
Comment: /

Hardware Setup: 1phase LISN ESH3-Z5 to ESU 26  
Level Unit: dBµV

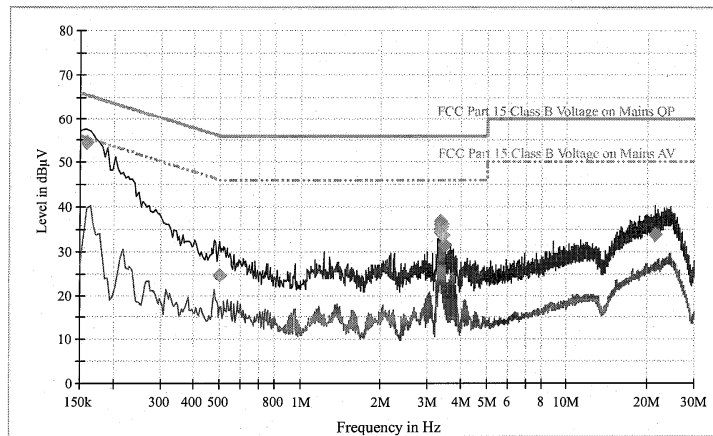

Subrange	Detectors	IF Bandwidth	Step Size	Meas. Time	Receiver
150kHz - 30MHz	Peak; Average	9kHz	4.5kHz	10ms	ESU 26

FCC Part 15 DV ESH3-Z5 150k to 30M ESU 26



Sign-off Test Data

Date: 3/17/2011 Time: 3:39:21

Tested by:  2011.3.23 Checked  
Reviewed by:  2011.3.23

**Prüfbericht - Nr.:** 16030075 001  
Test Report no.

Seite 2 von 37  
Page 2 of 37

**Radiated emission (below 1 GHz)**

TUV Rheinland (Guangdong) Ltd.

EMC Test Service Hotline: +86-20-28391188

**EMC Test Record (Emission)**

**Common Information**

Manufacturer: Desay  
Test Item: DVD player  
Identification: DX-WBRDVD1  
Test Standard: FCC Part 15  
Test Detail: RE  
Operation Mode: Normal mode  
Climate Condition: 23 °C; 50 %RH; 101 kPa.  
Test Voltage / Freq. : AC 120V / 60Hz  
Receipt No.: 173059541  
Report No. 16030075 001  
Result: Pass  
Comment: Test distance is 3m, Horizontal

Subrange 1  
Frequency Range: 30M-1GHz  
Receiver: TUV ESCI 3  
Transducer: TUV SAC UVLB 9168/ TUV ESCI 3-TUV SAC UVLB 9168

FCC 15.209 30M-1G sweep

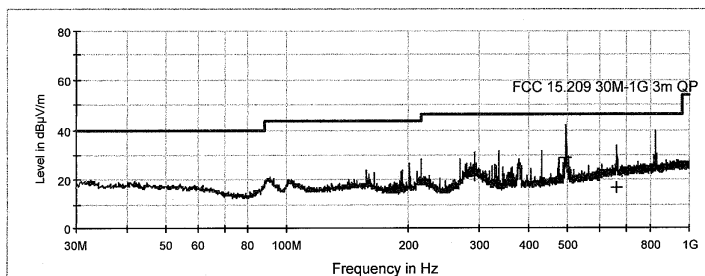



**Limit and Margin QP**

Frequency (MHz)	QuasiPeak (dBµV/m)	Corr. (dB)	Margin (dB)	Limit (dBµV/m)	Polarization
293.597500	21.5	12.7	24.5	46.0	H
496.102500	28.7	16.5	17.3	46.0	H
661.591250	16.8	19.2	29.2	46.0	H
826.976250	25.7	20.9	20.3	46.0	H

Sign-off Test Data

Date: 22/03/2011 - Time: 16:22:16

Tested by:  Reviewed by: 

**Prüfbericht - Nr.:** 16030075 001  
*Test Report no.*

Seite 3 von 37  
*Page 3 of 37*

TUV Rheinland (Guangdong) Ltd.

EMC Test Service Hotline: +86-20-28391188

## EMC Test Record (Emission)

### Common Information

Manufacturer: Desay  
Test Item: DVD player  
Identification: DX-WBRDVD1  
Test Standard: FCC Part 15  
Test Detail: RE  
Operation Mode: Normal mode  
Climate Condition: 23 °C; 50 %RH; 101 kPa.  
Test Voltage / Freq. : AC 120V / 60Hz  
Receipt No.: 173059541  
Report No. 16030075 001  
Result: Pass  
Comment: Test distance is 3m, Vertical

Subrange 1  
Frequency Range: 30M-1GHz  
Receiver: TUV ESCI 3  
Transducer: TUV SAC UVLB 9168/ TUV ESCI 3-TUV SAC UVLB 9168

FCC 15.209 30M-1G sweep

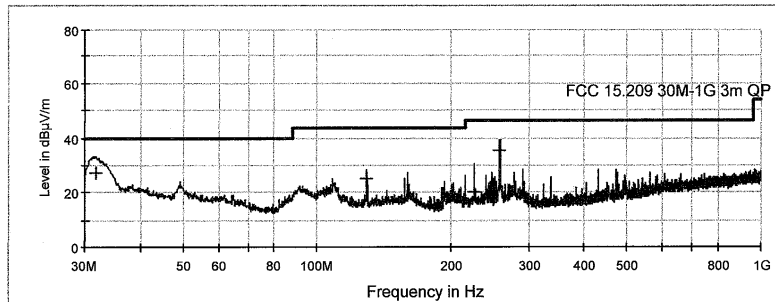

### Limit and Margin QP

Frequency (MHz)	QuasiPeak (dBµV/m)	Corr. (dB)	Margin (dB)	Limit (dBµV/m)	Polarization
31.950000	27.2	13.3	12.8	40.0	V
129.300000	25.1	12.8	18.4	43.5	V
226.900000	19.9	11.0	26.1	46.0	V
258.800000	35.5	11.8	10.5	46.0	V

*Sign-off Test Data*

Date: 22/03/2011 - Time: 16:49:05

Tested by:  2011.3.23  
Reviewed by: 

Prüfbericht - Nr.:

16030075 001

Seite 4 von 37

Page 4 of 37

Test Report no.

### Band Edge Emission

TUV Rheinland (Guangdong) Ltd.

EMC Test Service Hotline: +86-20-28391188

## EMC Test Record (Emission)

### Common Information

Manufacturer:	Desay
Test Item:	DVD player
Identification:	DX-WBRDVD1
Test Standard:	FCC Part 15
Test Detail:	Band edge
Operation Mode:	Tx @ Low Channel (B mode)
Climate Condition:	23 °C; 50 %RH; 101 kPa.
Test Voltage / Freq.:	AC 120V / 60Hz
Receipt No.:	173059541
Report No.:	16030075 001
Result:	Pass
Comment:	Test distance is 3m, Vertical

Subrange 1	
Frequency Range:	2GHz-3GHz
Receiver:	TUV FSP30
Transducer:	TUV SAC HF906/ TUV FSP30-TUV SAC HF906

Pre TUV 1 to 18G HF906

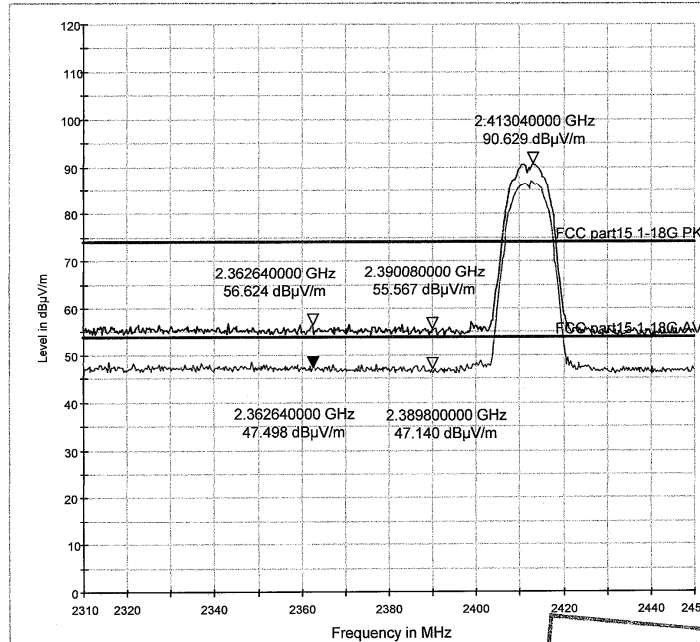

Sign-off Test Data

Date: 22/03/2011 - Time: 23:07:50

Tested by:  Checked Reviewed by:  Checked

**Prüfbericht - Nr.:** 16030075 001  
*Test Report no.*

Seite 5 von 37  
Page 5 of 37

TUV Rheinland (Guangdong) Ltd.

EMC Test Service Hotline: +86-20-28391188

## EMC Test Record (Emission)

### Common Information

Manufacturer:	Desay
Test Item:	DVD player
Identification:	DX-WBRDVD1
Test Standard:	FCC Part 15
Test Detail:	Band edge
Operation Mode:	Tx @ Low Channel (B mode)
Climate Condition:	23 °C; 50 %RH; 101 kPa.
Test Voltage / Freq.:	AC 120V / 60Hz
Receipt No.:	173059541
Report No.:	16030075 001
Result:	Pass
Comment:	Test distance is 3m, Horizontal

Subrange 1	
Frequency Range:	2GHz-3GHz
Receiver:	TUV FSP30
Transducer:	TUV SAC HF906/ TUV FSP30-TUV SAC HF906

Pre TUV 1 to 18G HF906

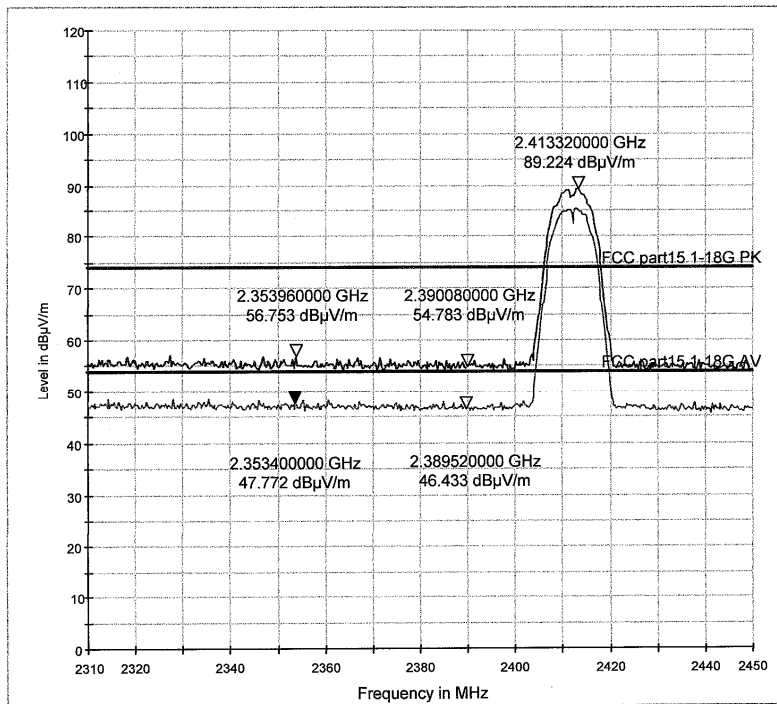

Sign-off Test Data

Date: 22/03/2011 - Time: 23:10:19

Tested by:

  
2011.3.23

Reviewed by:





Prüfbericht - Nr.: 16030075 001  
Test Report no.

Seite 6 von 37  
Page 6 of 37

TUV Rheinland (Guangdong) Ltd.

EMC Test Service Hotline: +86-20-28391188

## EMC Test Record (Emission)

### Common Information

Manufacturer:	Desay
Test Item:	DVD player
Identification:	DX-WBRDVD1
Test Standard:	FCC Part 15
Test Detail:	Band edge
Operation Mode:	Tx @ High Channel (B mode)
Climate Condition:	23 °C; 50 %RH; 101 kPa.
Test Voltage / Freq.:	AC 120V / 60Hz
Receipt No.:	173059541
Report No.:	16030075 001
Result:	Pass
Comment:	Test distance is 3m, Horizontal

Subrange 1	
Frequency Range:	2GHz-3GHz
Receiver:	TUV FSP30
Transducer:	TUV SAC HF906/ TUV FSP30-TUV SAC HF906

Pre TUV 1 to 18G HF906

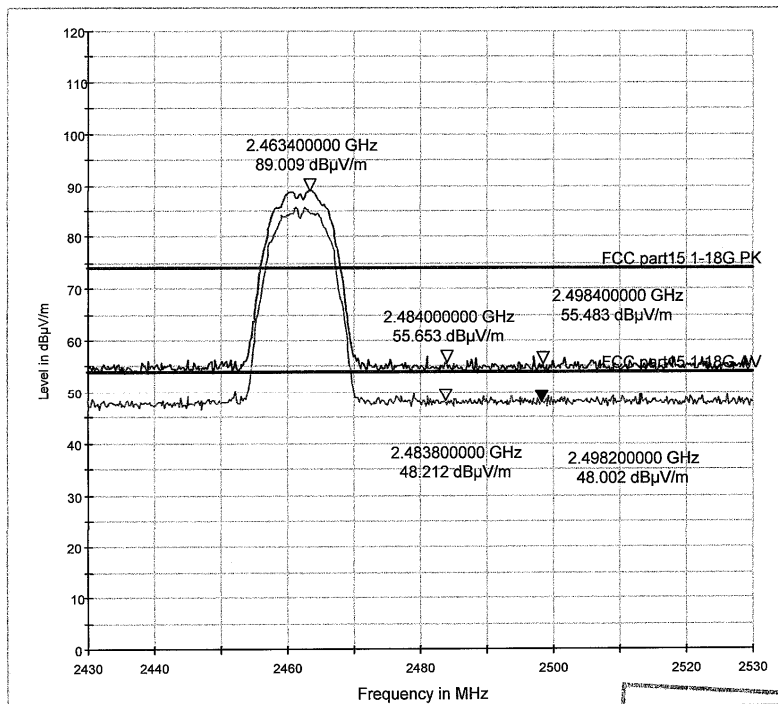

Sign-off Test Data

Date: 22/03/2011 - Time: 22:50:22

Tested by:  2011.3.23  
Reviewed by:  2011.3.23

**Prüfbericht - Nr.:** 16030075 001  
*Test Report no.*

Seite 7 von 37  
Page 7 of 37

TUV Rheinland (Guangdong) Ltd.

EMC Test Service Hotline: +86-20-28391188

## EMC Test Record (Emission)

### Common Information

Manufacturer:	Desay
Test Item:	DVD player
Identification:	DX-WBRDVD1
Test Standard:	FCC Part 15
Test Detail:	Band edge
Operation Mode:	Tx @ High Channel (B mode)
Climate Condition:	23 °C; 50 %RH; 101 kPa.
Test Voltage / Freq.:	AC 120V / 60Hz
Receipt No.:	173059541
Report No.:	16030075 001
Result:	Pass
Comment:	Test distance is 3m, Vertical

Subrange 1	
Frequency Range:	2GHz-3GHz
Receiver:	TUV FSP30
Transducer:	TUV SAC HF906/ TUV FSP30-TUV SAC HF906

Pre TUV 1 to 18G HF906

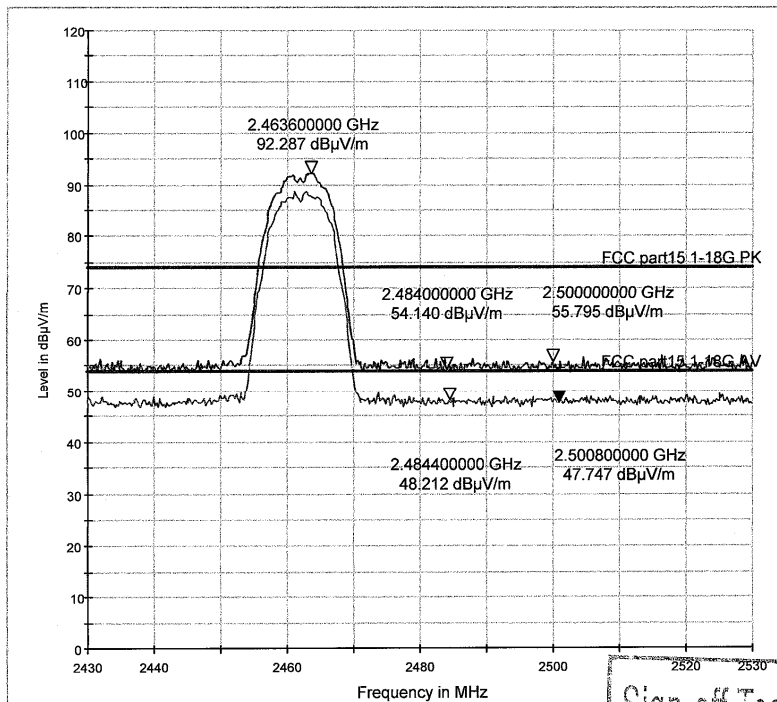

Sign-off Test Data

Date: 22/03/2011 - Time: 22:53:01

Tested by:  Reviewed by: 

**Prüfbericht - Nr.:** 16030075 001  
*Test Report no.*

**Seite 8 von 37**  
*Page 8 of 37*

TUV Rheinland (Guangdong) Ltd.

EMC Test Service Hotline: +86-20-28391188

## EMC Test Record (Emission)

### Common Information

Manufacturer:	Desay
Test Item:	DVD player
Identification:	DX-WBRDVD1
Test Standard:	FCC Part 15
Test Detail:	Band edge
Operation Mode:	Tx @ Low Channel (G mode)
Climate Condition:	23 °C; 50 %RH; 101 kPa.
Test Voltage / Freq.:	AC 120V / 60Hz
Receipt No.:	173059541
Report No.:	16030075 001
Result:	Pass
Comment:	Test distance is 3m, Horizontal

Subrange 1	
Frequency Range:	2GHz-3GHz
Receiver:	TUV FSP30
Transducer:	TUV SAC HF906/ TUV FSP30-TUV SAC HF906

Pre TUV 1 to 18G HF906

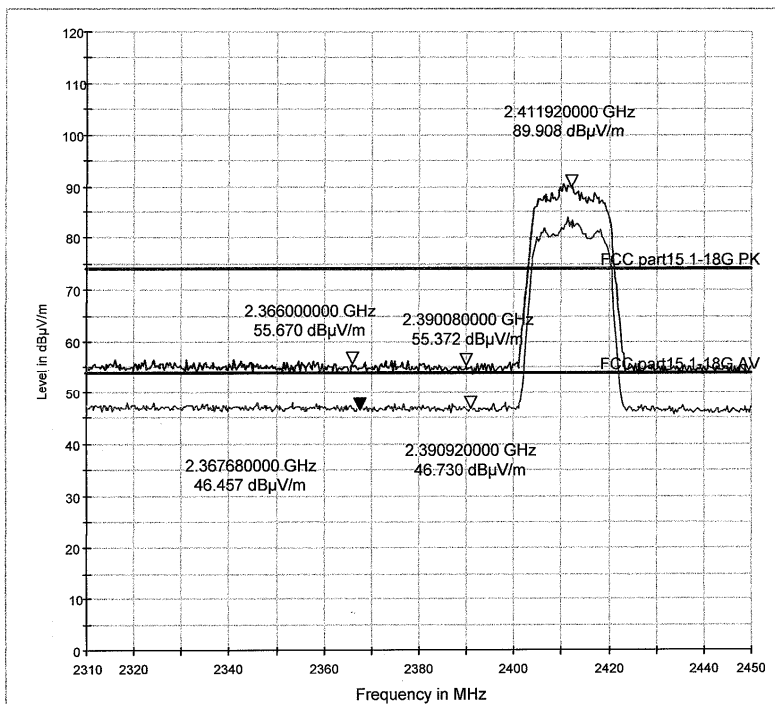

*Sign-off Test Data*

Date: 22/03/2011 - Time: 23:21:19

Tested by:  2011.3.23

Reviewed by:  2011.3.23

Prüfbericht - Nr.:

16030075 001

Seite 9 von 37

Test Report no.

Page 9 of 37

TUV Rheinland (Guangdong) Ltd.

EMC Test Service Hotline: +86-20-28391188

## EMC Test Record (Emission)

### Common Information

Manufacturer:	Desay
Test Item:	DVD player
Identification:	DX-WBRDVD1
Test Standard:	FCC Part 15
Test Detail:	Band edge
Operation Mode:	Tx @ Low Channel (G mode)
Climate Condition:	23 °C; 50 %RH; 101 kPa.
Test Voltage / Freq.:	AC 120V / 60Hz
Receipt No.:	173059541
Report No.:	16030075 001
Result:	Pass
Comment:	Test distance is 3m, Vertical

Subrange 1	
Frequency Range:	2GHz-3GHz
Receiver:	TUV FSP30
Transducer:	TUV SAC HF906/ TUV FSP30-TUV SAC HF906

Pre TUV 1 to 18G HF906

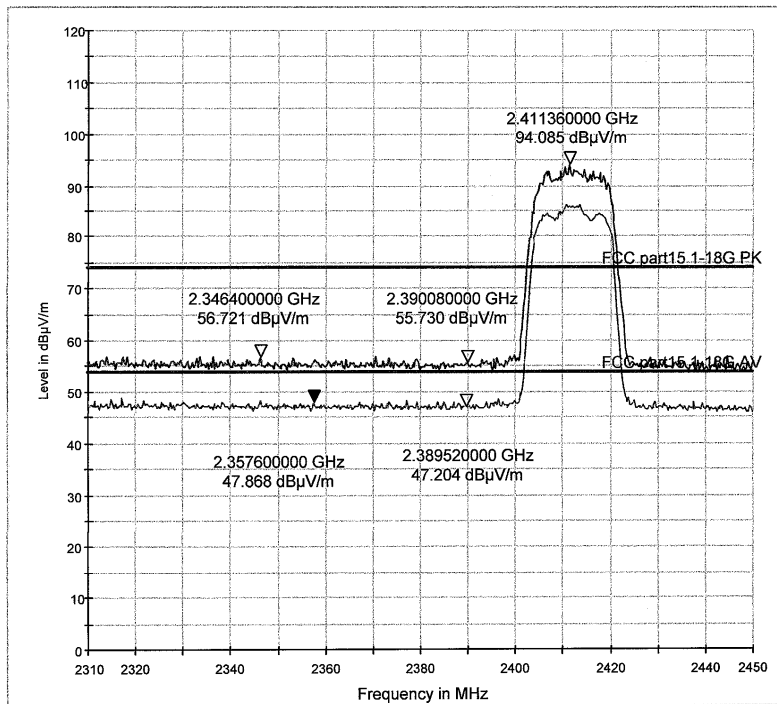

Sign-off Test Data

Date: 22/03/2011 - Time: 23:23:45

Tested by:

Reviewed by:



Prüfbericht - Nr.: 16030075 001  
Test Report no.

Seite 10 von 37  
Page 10 of 37

TUV Rheinland (Guangdong) Ltd.

EMC Test Service Hotline: +86-20-28391188

## EMC Test Record (Emission)

### Common Information

Manufacturer:	Desay
Test Item:	DVD player
Identification:	DX-WBRDVD1
Test Standard:	FCC Part 15
Test Detail:	Band edge
Operation Mode:	Tx @ High Channel (G mode)
Climate Condition:	23 °C; 50 %RH; 101 kPa.
Test Voltage / Freq.:	AC 120V / 60Hz
Receipt No.:	173059541
Report No.:	16030075 001
Result:	Pass
Comment:	Test distance is 3m, Horizontal

Subrange 1	
Frequency Range:	2GHz-3GHz
Receiver:	TUV FSP30
Transducer:	TUV SAC HF906/ TUV FSP30-TUV SAC HF906

Pre TUV 1 to 18G HF906

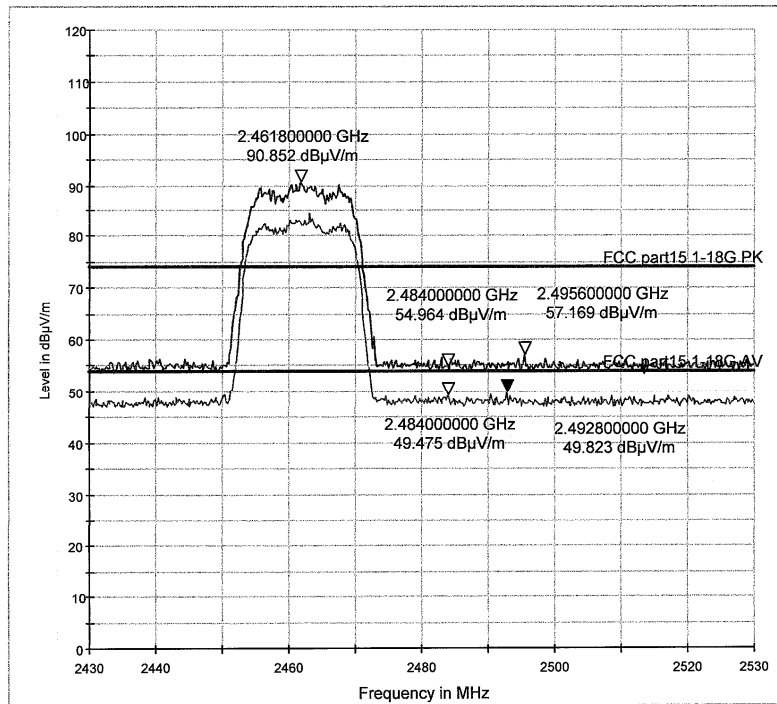

Sign-off Test Data

Date: 22/03/2011 - Time: 22:46:51

Tested by:  2011 3 23

Reviewed by:  KK 2011 3 23

**Prüfbericht - Nr.:** 16030075 001  
*Test Report no.*

Seite 11 von 37  
Page 11 of 37

TUV Rheinland (Guangdong) Ltd.

EMC Test Service Hotline: +86-20-28391188

## EMC Test Record (Emission)

### Common Information

Manufacturer:	Desay
Test Item:	DVD player
Identification:	DX-WBRDVD1
Test Standard:	FCC Part 15
Test Detail:	Band edge
Operation Mode:	Tx @ High Channel (Gmode)
Climate Condition:	23 °C; 50 %RH; 101 kPa.
Test Voltage / Freq.:	AC 120V / 60Hz
Receipt No.:	173059541
Report No.:	16030075 001
Result:	Pass
Comment:	Test distance is 3m, Vertical

Subrange 1	
Frequency Range:	2GHz-3GHz
Receiver:	TUV FSP30
Transducer:	TUV SAC HF906/ TUV FSP30-TUV SAC HF906

Pre TUV 1 to 18G HF906

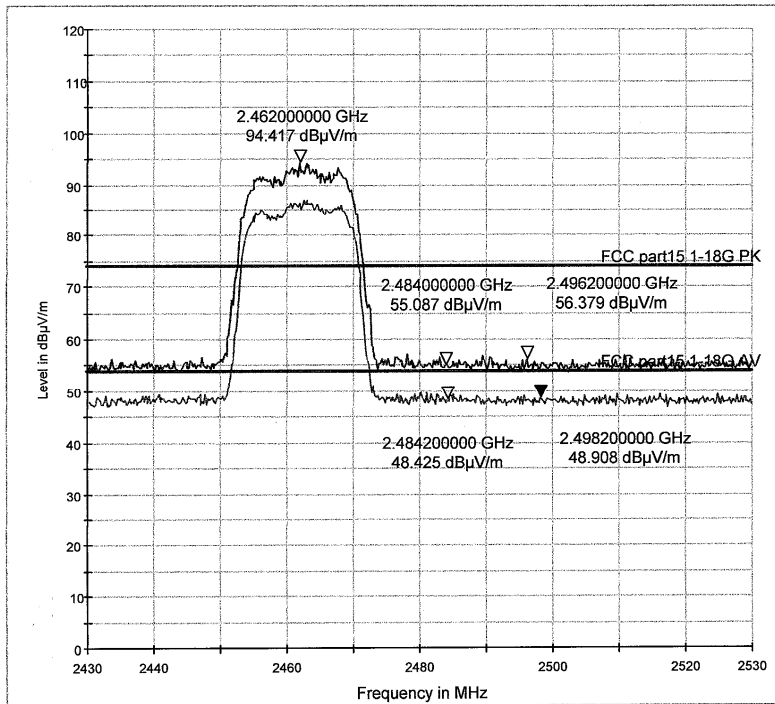

*Sign-off Test Data*

Date: 22/03/2011 - Time: 22:44:19

Tested by:



Reviewed by:



**Prüfbericht - Nr.:** 16030075 001  
*Test Report no.*

Seite 12 von 37  
*Page 12 of 37*

TUV Rheinland (Guangdong) Ltd.

EMC Test Service Hotline: +86-20-28391188

## EMC Test Record (Emission)

### Common Information

Manufacturer:	Desay
Test Item:	DVD player
Identification:	DX-WBRDVD1
Test Standard:	FCC Part 15
Test Detail:	Band edge
Operation Mode:	Tx @ Low Channel (HT20 mode)
Climate Condition:	23 °C; 50 %RH; 101 kPa.
Test Voltage / Freq.:	AC 120V / 60Hz
Receipt No.:	173059541
Report No.:	16030075 001
Result:	Pass
Comment:	Test distance is 3m, Horizontal

Subrange 1	
Frequency Range:	2GHz-3GHz
Receiver:	TUV FSP30
Transducer:	TUV SAC HF906/ TUV FSP30-TUV SAC HF906

Pre TUV 1 to 18G HF906

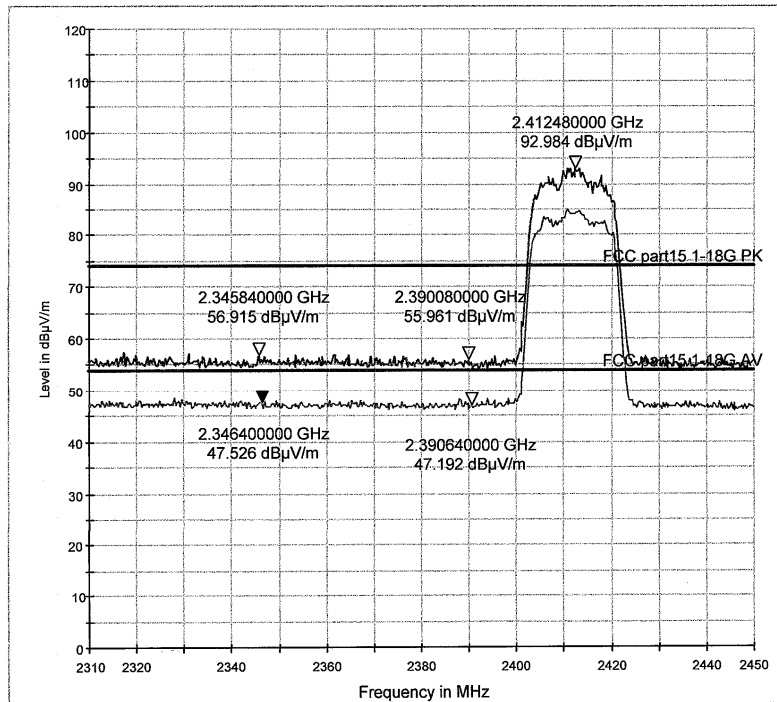

Sign-off Test Data

Date: 22/03/2011 - Time: 22:26:08

Tested by:  2011.3.23  
Checked

Reviewed by:  2011.3.23  
Checked

Prüfbericht - Nr.:

16030075 001

Seite 13 von 37

Page 13 of 37

Test Report no.

TUV Rheinland (Guangdong) Ltd.

EMC Test Service Hotline: +86-20-28391188

## EMC Test Record (Emission)

### Common Information

Manufacturer:	Desay
Test Item:	DVD player
Identification:	DX-WBRDVD1
Test Standard:	FCC Part 15
Test Detail:	Band edge
Operation Mode:	Tx @ Low Channel (HT20 mode)
Climate Condition:	23 °C; 50 %RH; 101 kPa.
Test Voltage / Freq.:	AC 120V / 60Hz
Receipt No.:	173059541
Report No.:	16030075 001
Result:	Pass
Comment:	Test distance is 3m, Vertical

Subrange 1	
Frequency Range:	2GHz-3GHz
Receiver:	TUV FSP30
Transducer:	TUV SAC HF906/ TUV FSP30-TUV SAC HF906

Pre TUV 1 to 18G HF906

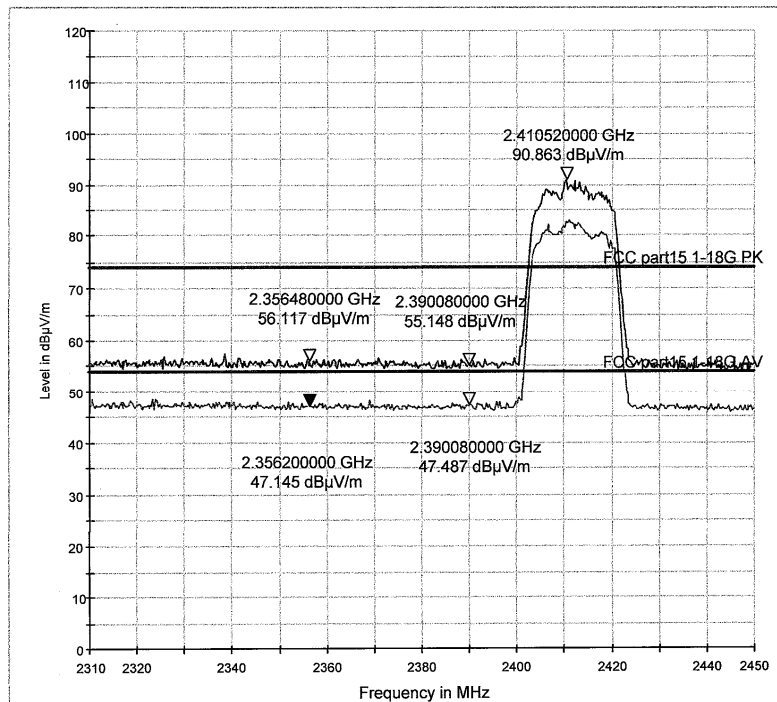

Sign-off Test Data

Date: 22/03/2011 Time: 22:23:50

Tested by:



Reviewed by:





Prüfbericht - Nr.: 16030075 001  
Test Report no.

Seite 14 von 37  
Page 14 of 37

TUV Rheinland (Guangdong) Ltd.

EMC Test Service Hotline: +86-20-28391188

## EMC Test Record (Emission)

### Common Information

Manufacturer:	Desay
Test Item:	DVD player
Identification:	DX-WBRDVD1
Test Standard:	FCC Part 15
Test Detail:	Band edge
Operation Mode:	Tx @ High Channel (HT20 mode)
Climate Condition:	23 °C; 50 %RH; 101 kPa.
Test Voltage / Freq. :	AC 120V / 60Hz
Receipt No.:	173059541
Report No.:	16030075 001
Result:	Pass
Comment:	Test distance is 3m, Horizontal

Subrange 1	
Frequency Range:	2GHz-3GHz
Receiver:	TUV FSP30
Transducer:	TUV SAC HF906/ TUV FSP30-TUV SAC HF906

Pre TUV 1 to 18G HF906

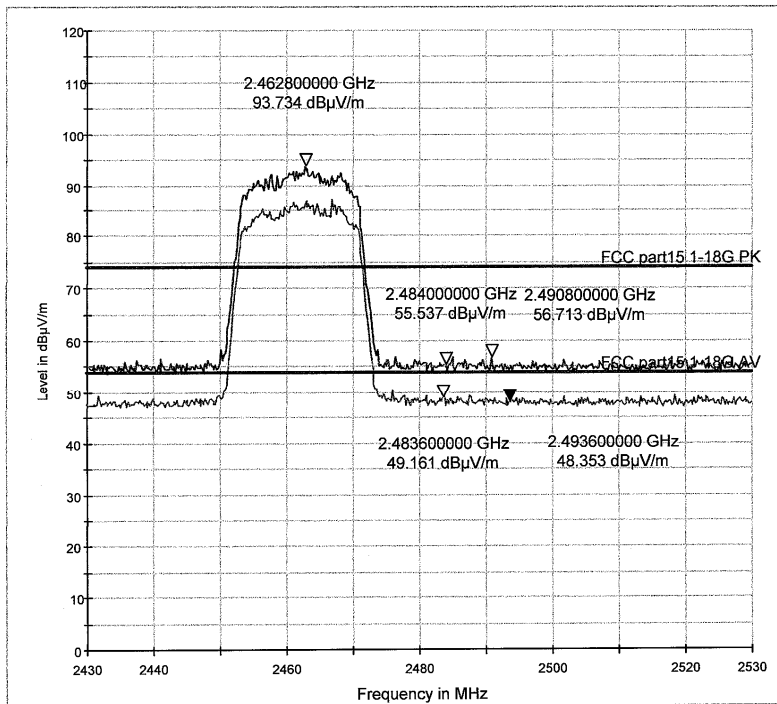

Sign-off Test Data

Date: 22/03/2011 - Time: 22:34:29

Tested by:



Reviewed by:



Prüfbericht - Nr.: 16030075 001  
Test Report no.

Seite 15 von 37  
Page 15 of 37

TUV Rheinland (Guangdong) Ltd.

EMC Test Service Hotline: +86-20-28391188

### EMC Test Record (Emission)

#### Common Information

Manufacturer:	Desay
Test Item:	DVD player
Identification:	DX-WBRDVD1
Test Standard:	FCC Part 15
Test Detail:	Band edge
Operation Mode:	Tx @ High Channel (HT20 mode)
Climate Condition:	23 °C; 50 %RH; 101 kPa.
Test Voltage / Freq. :	AC 120V / 60Hz
Receipt No.:	173059541
Report No.:	16030075 001
Result:	Pass
Comment:	Test distance is 3m, Vertical

Subrange 1	
Frequency Range:	2GHz-3GHz
Receiver:	TUV FSP30
Transducer:	TUV SAC HF906/ TUV FSP30-TUV SAC HF906

Pre TUV 1 to 18G HF906

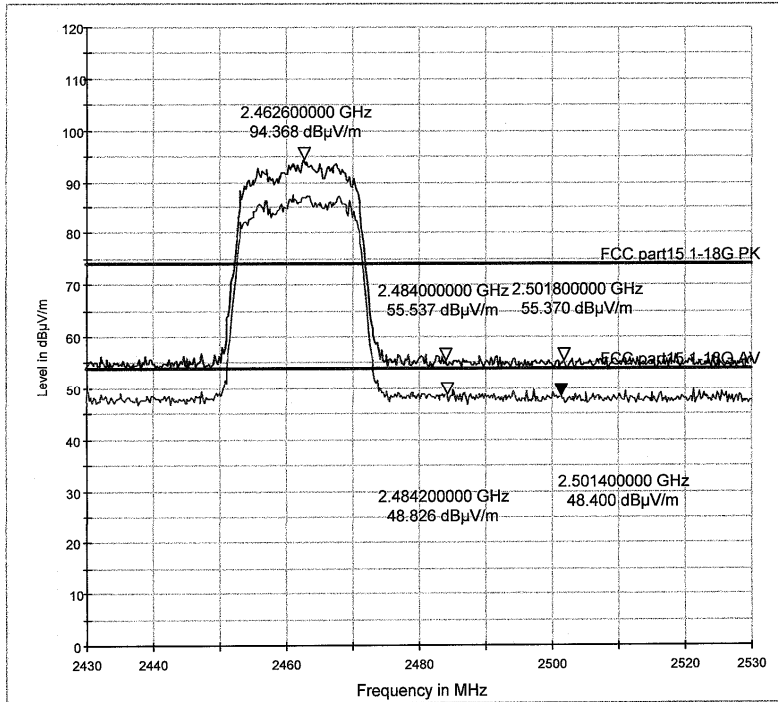

Sign-off Test Data

Date: 22/03/2011 Time: 22:37:42

Tested by:  Reviewed by: 

**Prüfbericht - Nr.:** 16030075 001  
*Test Report no.*

Seite 16 von 37  
*Page 16 of 37*

TUV Rheinland (Guangdong) Ltd.

EMC Test Service Hotline: +86-20-28391188

## EMC Test Record (Emission)

### Common Information

Manufacturer:	Desay
Test Item:	DVD player
Identification:	DX-WBRDVD1
Test Standard:	FCC Part 15
Test Detail:	Band edge
Operation Mode:	Tx @ Low Channel (HT40 mode)
Climate Condition:	23 °C; 50 %RH; 101 kPa.
Test Voltage / Freq. :	AC 120V / 60Hz
Receipt No.:	173059541
Report No.:	16030075 001
Result:	Pass
Comment:	Test distance is 3m, Horizontal

Subrange 1	
Frequency Range:	2GHz-3GHz
Receiver:	TUV FSP30
Transducer:	TUV SAC HF906/ TUV FSP30-TUV SAC HF906

Pre TUV 1 to 18G HF906

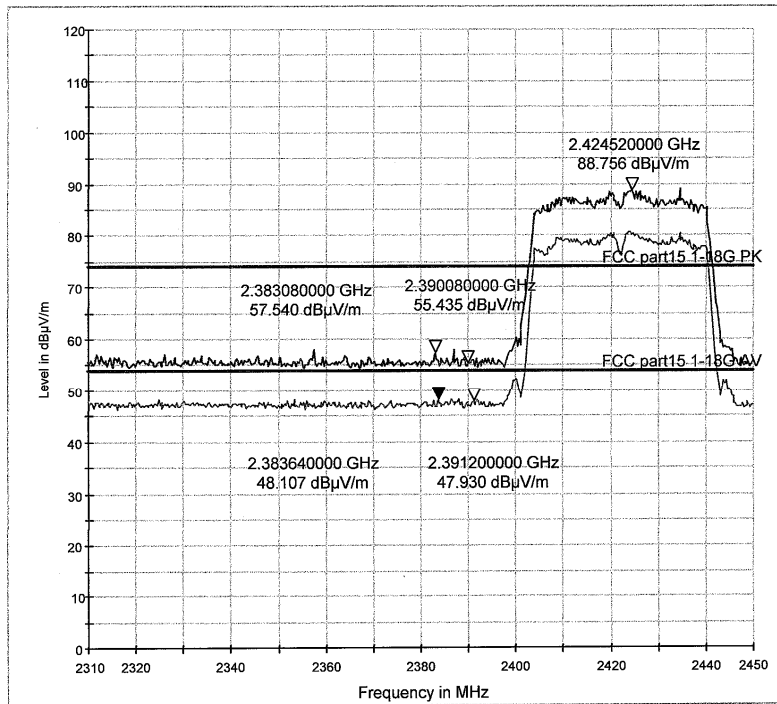

**Sign-off Test Data**

Date: 22/03/2014 Time: 22:17:42

Tested by:  Reviewed by: 

Prüfbericht - Nr.: 16030075 001  
Test Report no.

Seite 17 von 37  
Page 17 of 37

TUV Rheinland (Guangdong) Ltd.

EMC Test Service Hotline: +86-20-28391188

## EMC Test Record (Emission)

### Common Information

Manufacturer:	Desay
Test Item:	DVD player
Identification:	DX-WBRDVD1
Test Standard:	FCC Part 15
Test Detail:	Band edge
Operation Mode:	Tx @ Low Channel (HT40 mode)
Climate Condition:	23 °C; 50 %RH; 101 kPa.
Test Voltage / Freq.:	AC 120V / 60Hz
Receipt No.:	173059541
Report No.:	16030075 001
Result:	Pass
Comment:	Test distance is 3m, Vertical

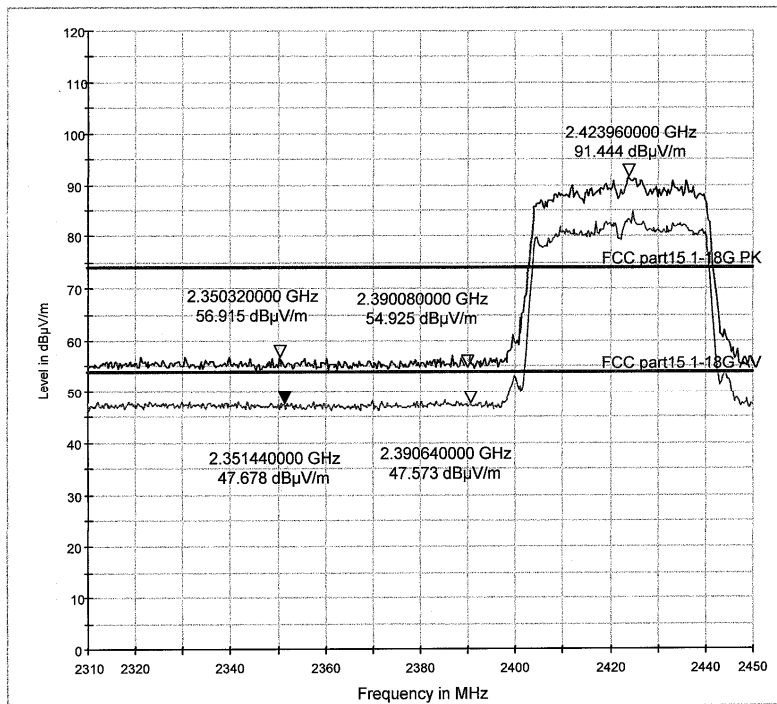

Subrange 1	
Frequency Range:	2GHz-3GHz
Receiver:	TUV FSP30
Transducer:	TUV SAC HF906/ TUV FSP30-TUV SAC HF906

Pre TUV 1 to 18G HF906



Sign-off Test Data

Date: 22/03/2011 Time: 22:20:08

Tested by:  2011.3.23, Reviewed by:  2011.3.23

Prüfbericht - Nr.:

16030075 001

Seite 18 von 37

Page 18 of 37

Test Report no.

TUV Rheinland (Guangdong) Ltd.

EMC Test Service Hotline: +86-20-28391188

## EMC Test Record (Emission)

### Common Information

Manufacturer:	Desay
Test Item:	DVD player
Identification:	DX-WBRDVD1
Test Standard:	FCC Part 15
Test Detail:	Band edge
Operation Mode:	Tx @ High Channel (HT40 mode)
Climate Condition:	23 °C; 50 %RH; 101 kPa.
Test Voltage / Freq.:	AC 120V / 60Hz
Receipt No.:	173059541
Report No.:	16030075 001
Result:	Pass
Comment:	Test distance is 3m, Vertical

Subrange 1	
Frequency Range:	2GHz-3GHz
Receiver:	TUV FSP30
Transducer:	TUV SAC HF906/ TUV FSP30-TUV SAC HF906

Pre TUV 1 to 18G HF906

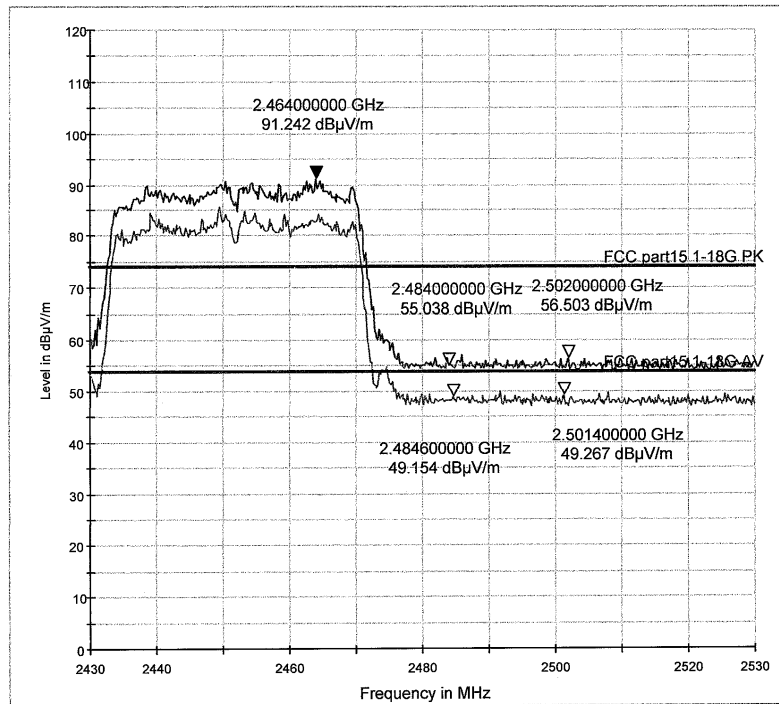

Sign-off Test Data

Date: 22/03/2011 Time: 22:05:53

Tested by:

Reviewed by:



Prüfbericht - Nr.: 16030075 001  
Test Report no.

Seite 19 von 37  
Page 19 of 37

TUV Rheinland (Guangdong) Ltd.

EMC Test Service Hotline: +86-20-28391188

### EMC Test Record (Emission)

#### Common Information

Manufacturer:	Desay
Test Item:	DVD player
Identification:	DX-WBRDVD1
Test Standard:	FCC Part 15
Test Detail:	Band edge
Operation Mode:	Tx @ High Channel (HT40 mode)
Climate Condition:	23 °C; 50 %RH; 101 kPa.
Test Voltage / Freq. :	AC 120V / 60Hz
Receipt No.:	173059541
Report No.:	16030075 001
Result:	Pass
Comment:	Test distance is 3m, Horizontal

Subrange 1	
Frequency Range:	2GHz-3GHz
Receiver:	TUV FSP30
Transducer:	TUV SAC HF906/ TUV FSP30-TUV SAC HF906

Pre TUV 1 to 18G HF906

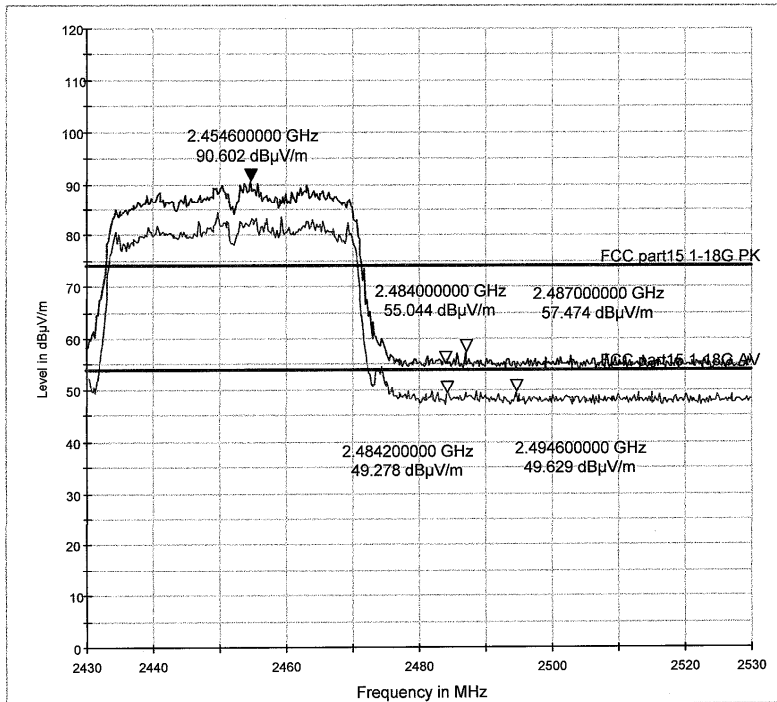

Sign-off Test Data

Date: 22/03/2011 - Time: 22:09:30

Tested by:



Reviewed by:



Prüfbericht - Nr.:

16030075 001

Seite 20 von 37

Page 20 of 37

Test Report no.

### 6dB bandwidth (802.11b 2412MHz)

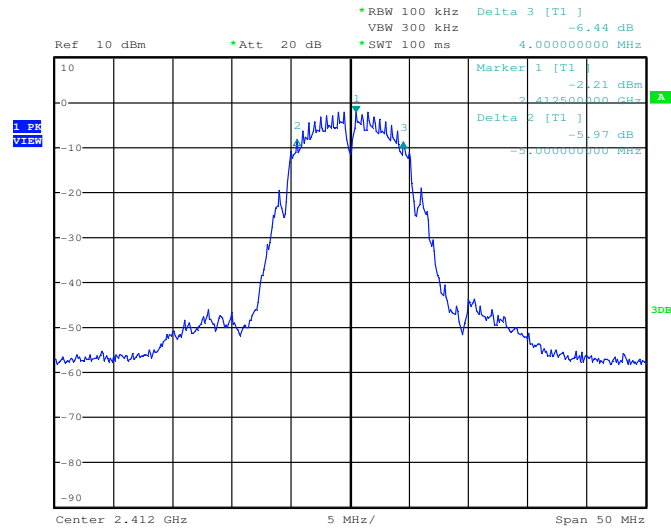

Date: 14.MAR.2011 21:20:05

### 6dB bandwidth (802.11b 2437MHz)

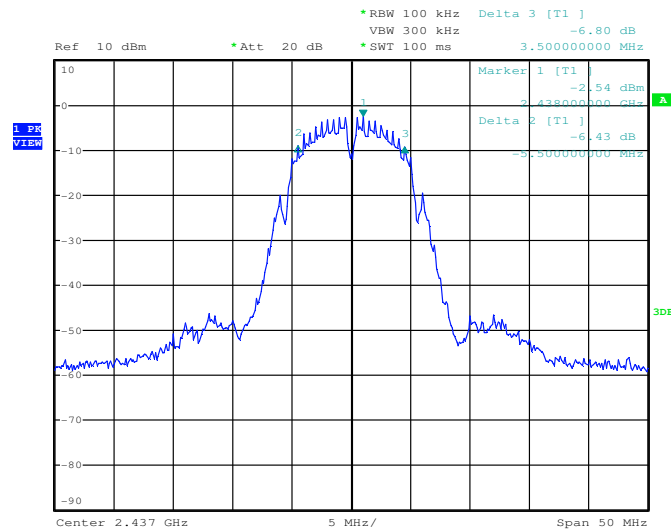

Date: 14.MAR.2011 21:28:08

Prüfbericht - Nr.:

16030075 001

Seite 21 von 37

Page 21 of 37

Test Report no.

### 6dB bandwidth (802.11b 2462MHz)

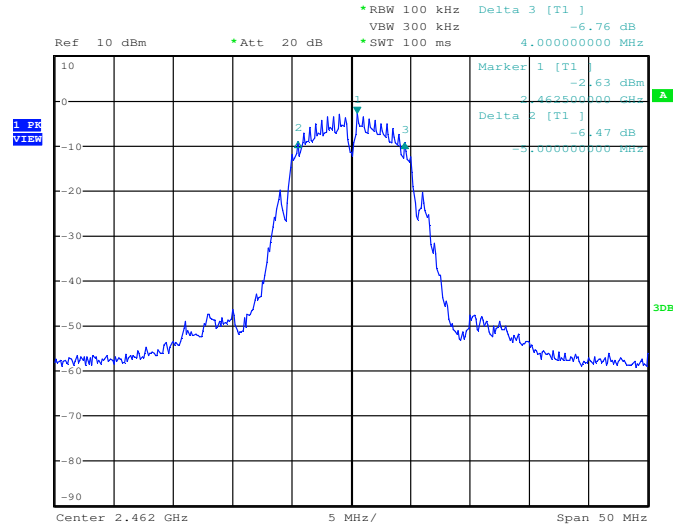

Date: 14.MAR.2011 21:29:56

### 6dB bandwidth (802.11g 2412MHz)

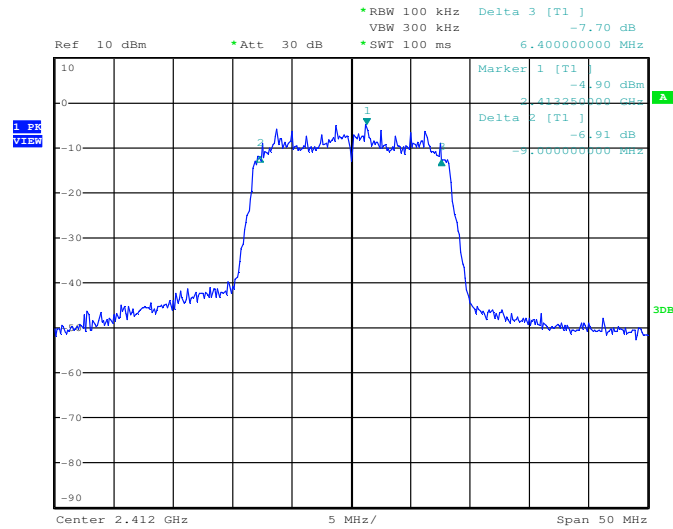

Date: 14.MAR.2011 21:52:12



Prüfbericht - Nr.:

16030075 001

Seite 22 von 37

Page 22 of 37

Test Report no.

### 6dB bandwidth (802.11g 2437MHz)

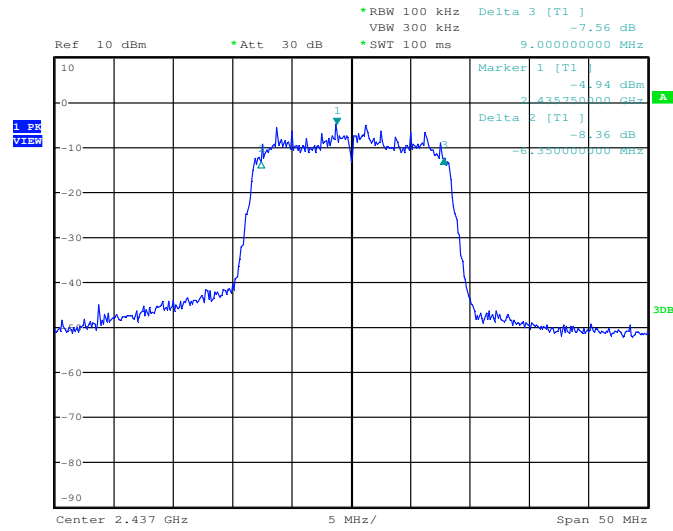

Date: 14.MAR.2011 21:54:08

### 6dB bandwidth (802.11g 2462MHz)

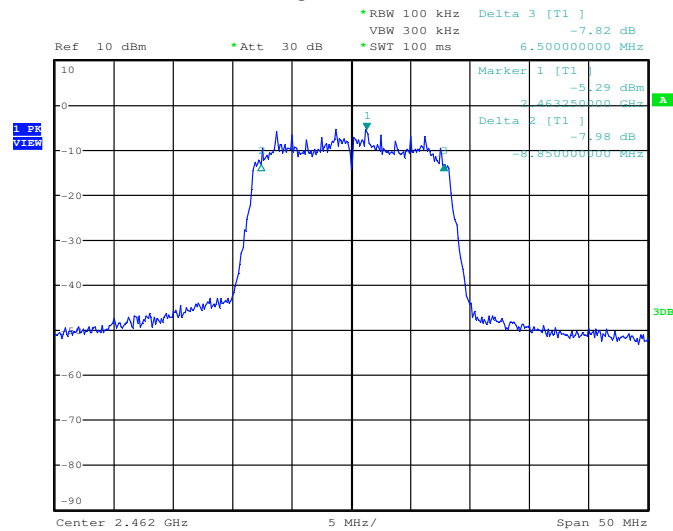

Date: 14.MAR.2011 21:56:10

Prüfbericht - Nr.:

16030075 001

Seite 23 von 37

Page 23 of 37

Test Report no.

6dB bandwidth (802.11n HT20 2412MHz)

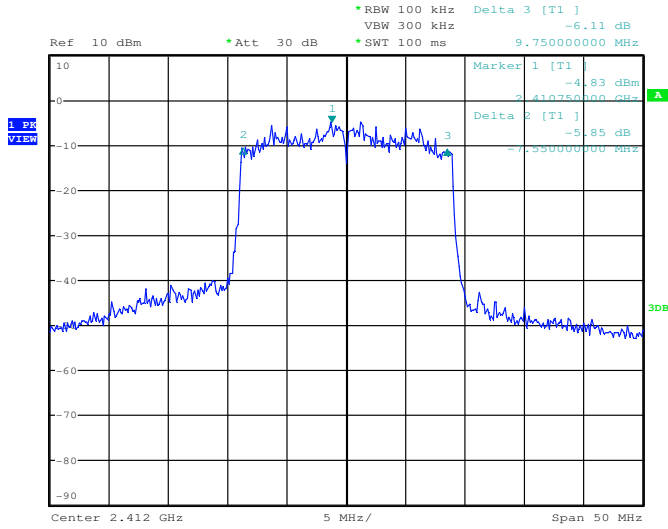

Date: 14.MAR.2011 22:07:20

6dB bandwidth (802.11n HT20 2437MHz)

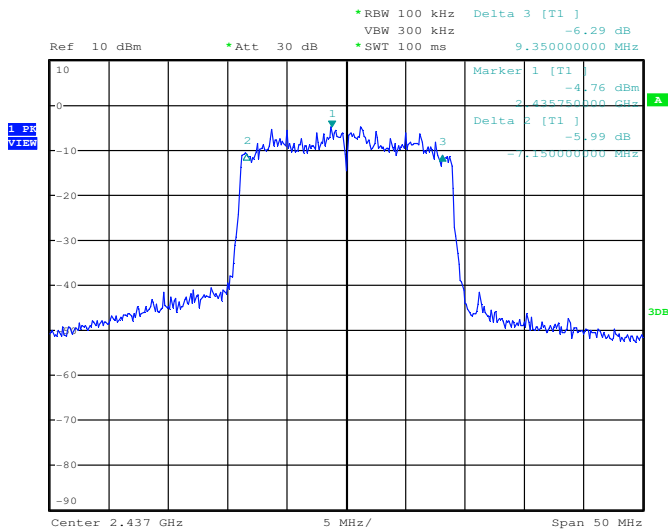

Date: 14.MAR.2011 22:04:29

Prüfbericht - Nr.:

16030075 001

Seite 24 von 37

Test Report no.

Page 24 of 37

6dB bandwidth (802.11n HT20 2462MHz)

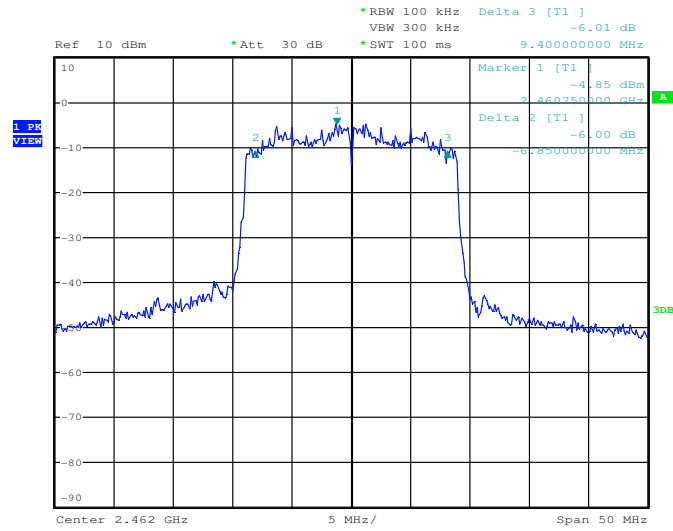

Date: 14.MAR.2011 22:02:43

6dB bandwidth (802.11n HT40 2422MHz)

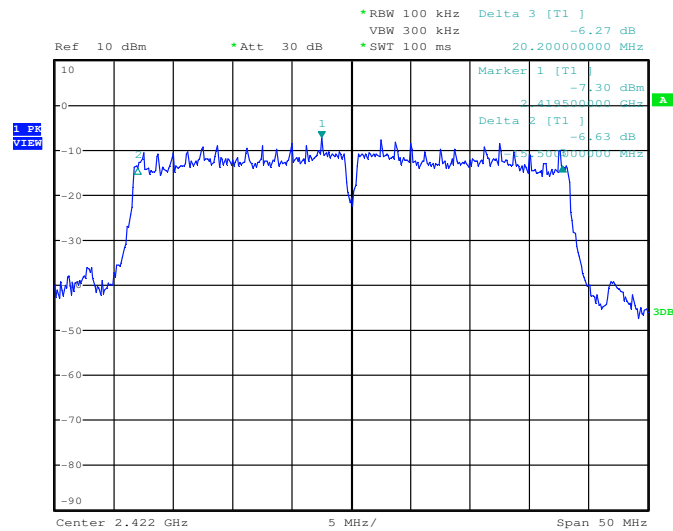

Date: 14.MAR.2011 22:10:26

Prüfbericht - Nr.: 16030075 001  
Test Report no.

Seite 25 von 37  
Page 25 of 37

6dB bandwidth (802.11n HT20 2437MHz)

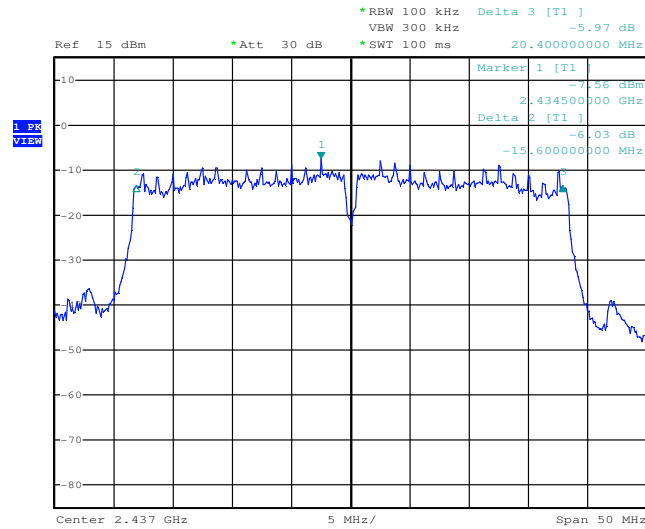

Date: 14.MAR.2011 22:13:40

6dB bandwidth (802.11n HT20 2452MHz)

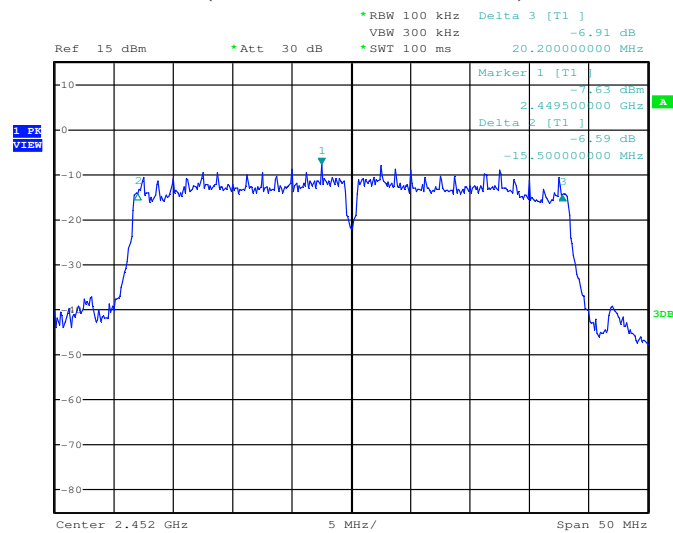

Date: 14.MAR.2011 22:15:16

Prüfbericht - Nr.: 16030075 001  
Test Report no.

Seite 26 von 37  
Page 26 of 37

Power spectral density (802.11b 2412MHz)

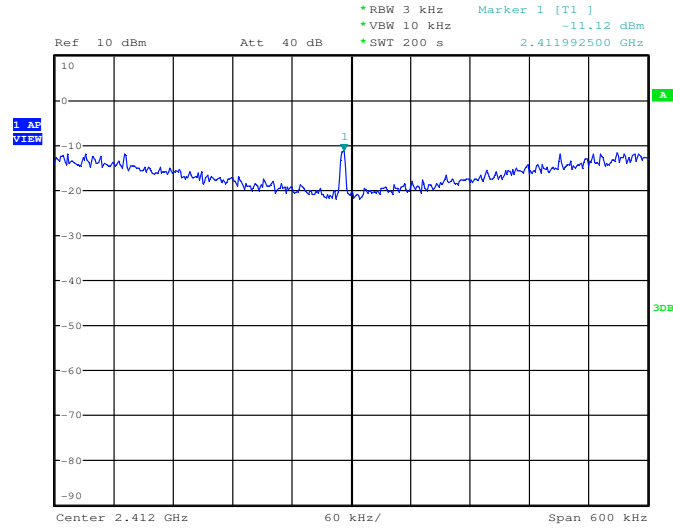

Date: 15.MAR.2011 02:01:03

Power spectral density (802.11b 2437MHz)

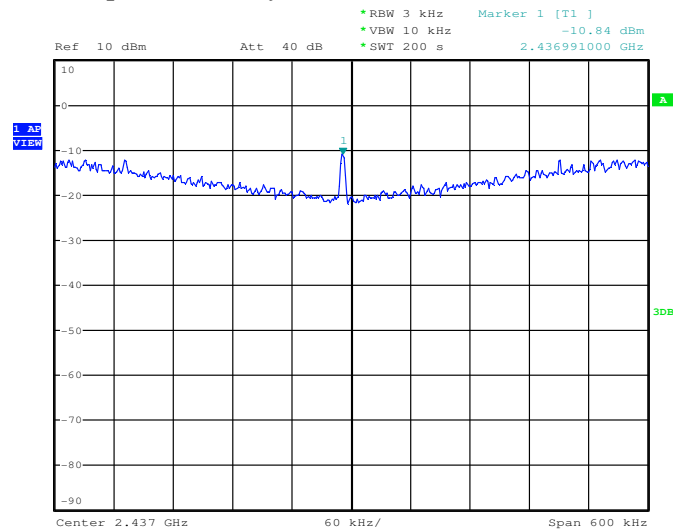

Date: 15.MAR.2011 02:06:13

**Prüfbericht - Nr.:** 16030075 001  
*Test Report no.*

**Seite 27 von 37**  
*Page 27 of 37*

**Power spectral density (802.11b 2462MHz)**

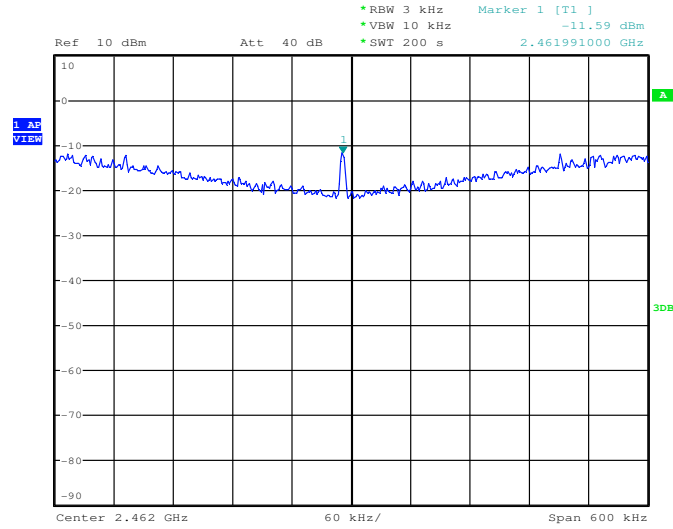

Date: 15.MAR.2011 02:10:38

**Power spectral density (802.11g 2412MHz)**

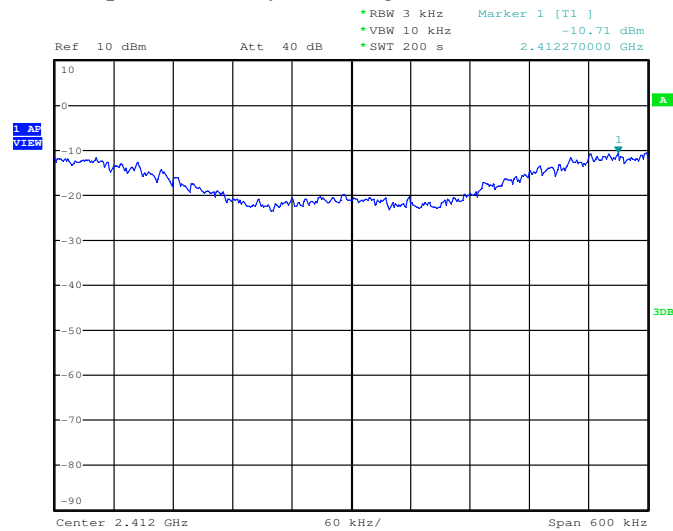

Date: 15.MAR.2011 01:56:18

**Prüfbericht - Nr.:** 16030075 001  
*Test Report no.*

**Seite 28 von 37**  
*Page 28 of 37*

**Power spectral density (802.11g 2437MHz)**

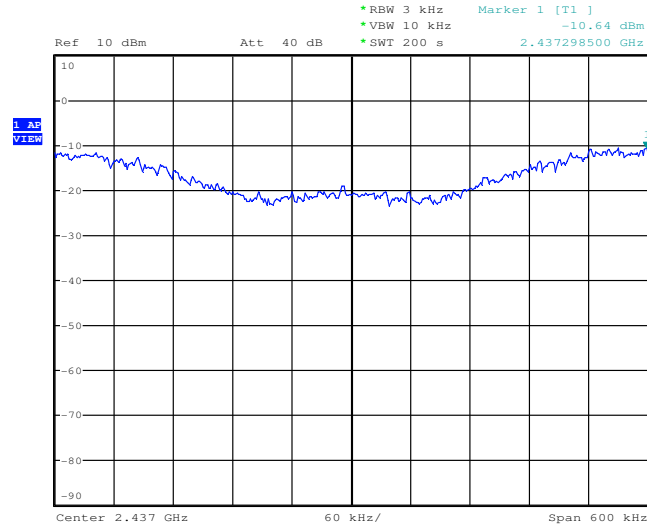

Date: 15.MAR.2011 01:51:40

**Power spectral density (802.11g 2462MHz)**

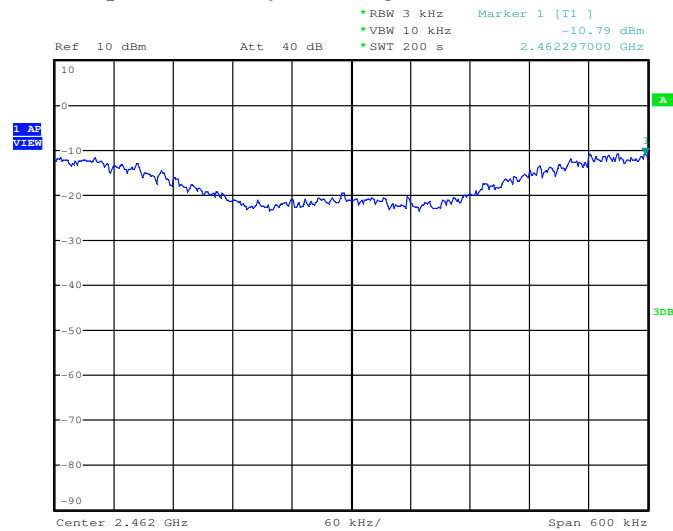

Date: 15.MAR.2011 01:46:44

Prüfbericht - Nr.: 16030075 001  
Test Report no.

Seite 29 von 37  
Page 29 of 37

Power spectral density (802.11n HT20 2412MHz)

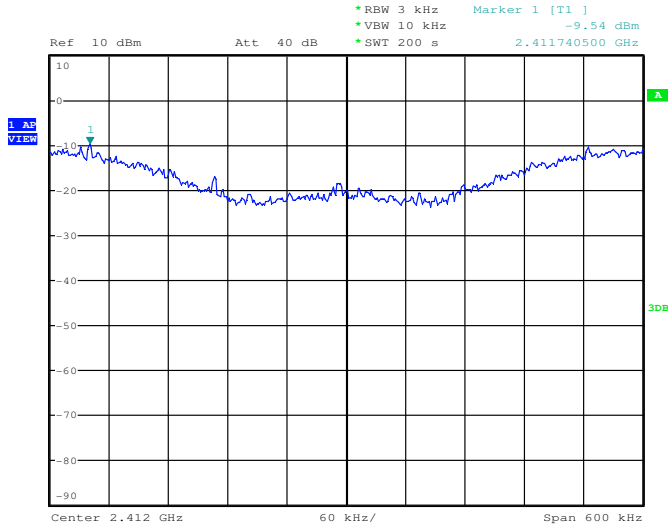

Date: 15.MAR.2011 02:26:22

Power spectral density (802.11n HT20 2437MHz)

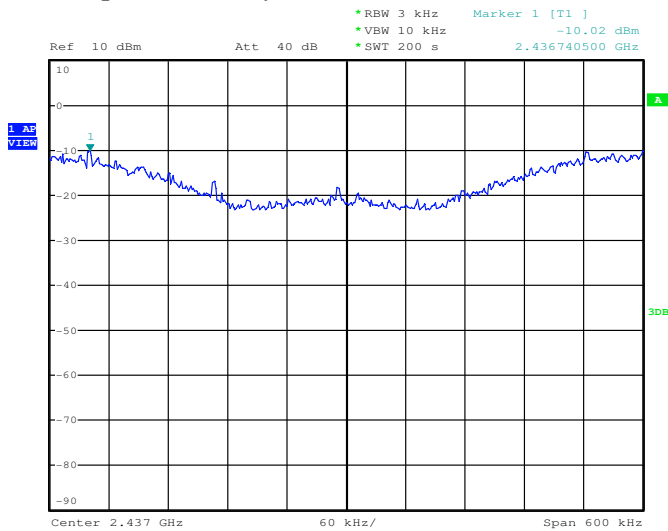

Date: 15.MAR.2011 02:21:41



Prüfbericht - Nr.: 16030075 001  
Test Report no.

Seite 30 von 37  
Page 30 of 37

Power spectral density (802.11n HT20 2462MHz)

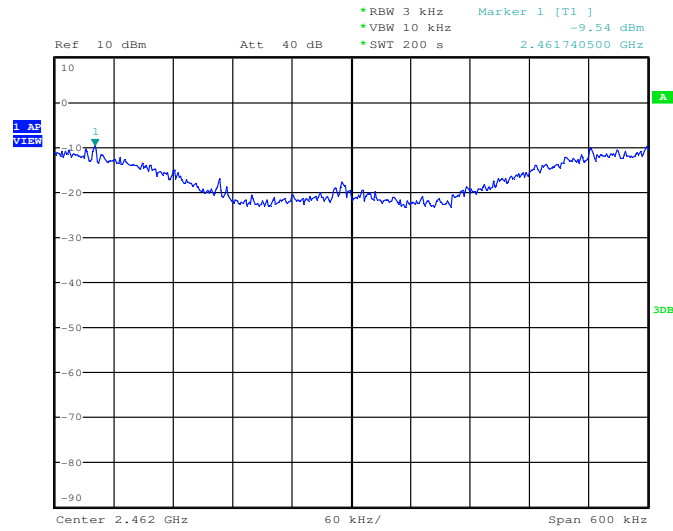

Date: 15.MAR.2011 02:17:12

Power spectral density (802.11n HT40 2422MHz)

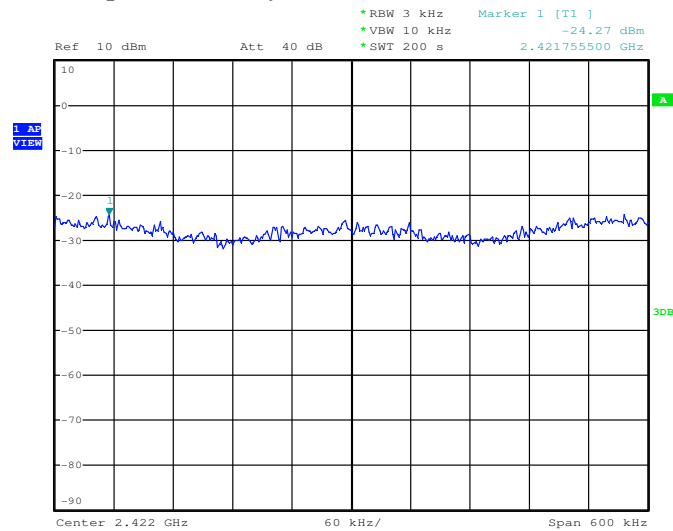

Date: 15.MAR.2011 02:32:25

Prüfbericht - Nr.:

16030075 001

Seite 31 von 37

Page 31 of 37

Test Report no.

Power spectral density (802.11n HT40 2437MHz)

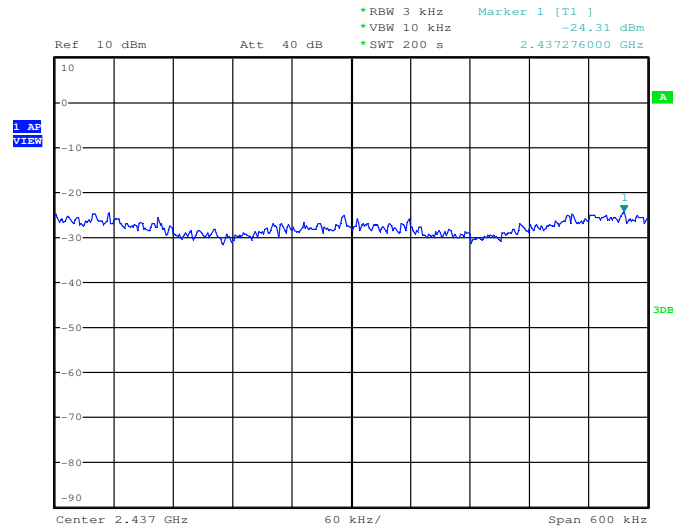

Date: 15.MAR.2011 02:36:50

Power spectral density (802.11n HT40 2452MHz)

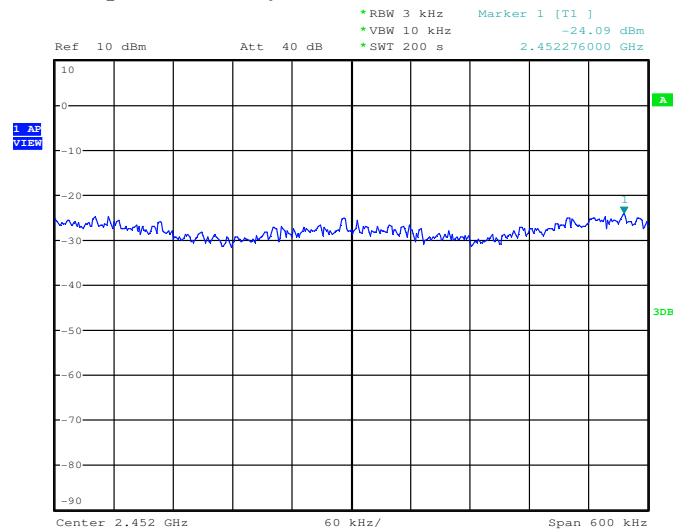

Date: 15.MAR.2011 02:41:19

Prüfbericht - Nr.:

16030075 001

Seite 32 von 37

Page 32 of 37

Test Report no.

Out of band conducted emission (802.11b 2412MHz)

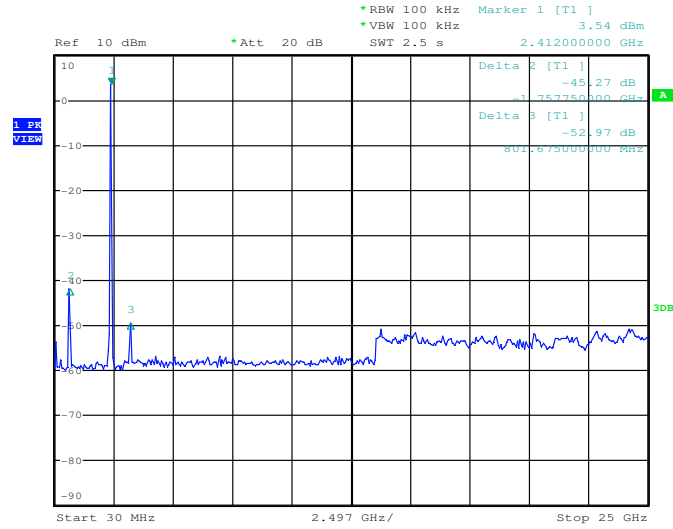

Date: 15.MAR.2011 02:52:47

Out of band conducted emission (802.11b 2437MHz)

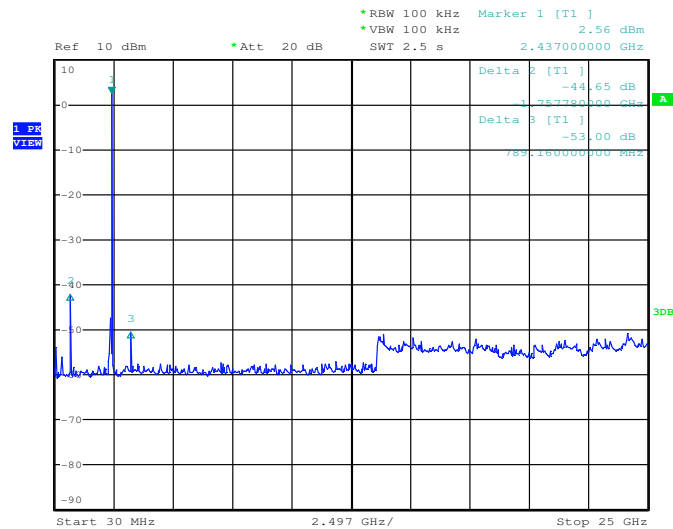

Date: 15.MAR.2011 02:57:00

Prüfbericht - Nr.:

16030075 001

Seite 33 von 37

Page 33 of 37

Test Report no.

Out of band conducted emission (802.11b 2462MHz)

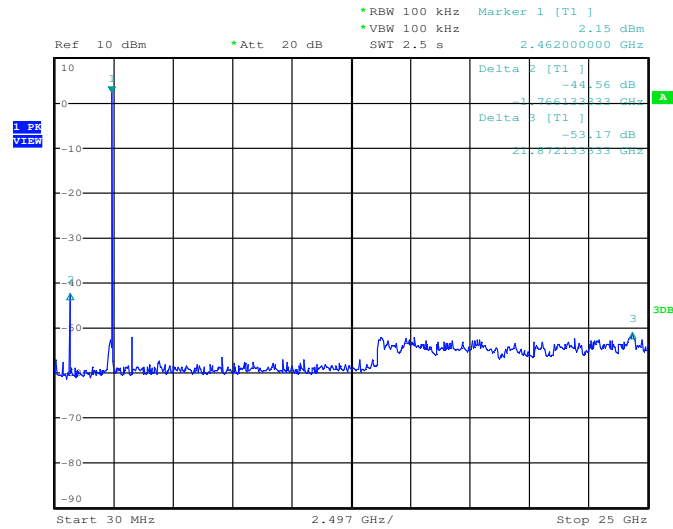

Date: 15.MAR.2011 03:02:30

Out of band conducted emission (802.11g 2412MHz)

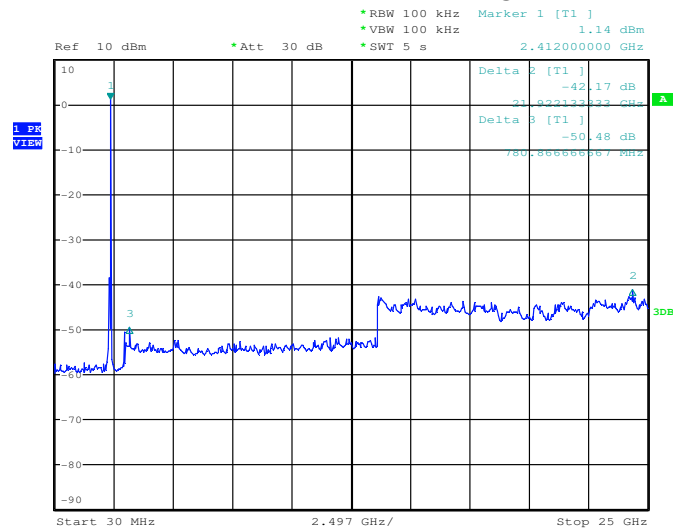

Date: 15.MAR.2011 03:51:04

Prüfbericht - Nr.: 16030075 001  
Test Report no.

Seite 34 von 37  
Page 34 of 37

### Out of band conducted emission (802.11g 2437MHz)

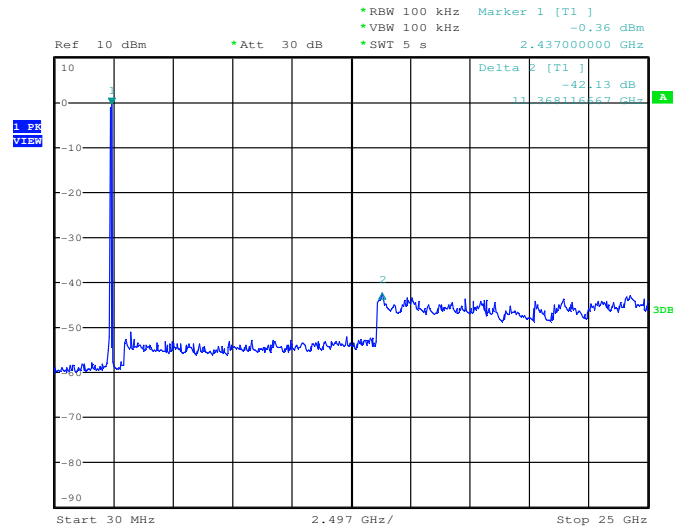

Date: 15.MAR.2011 03:53:01

### Out of band conducted emission (802.11g 2462MHz)

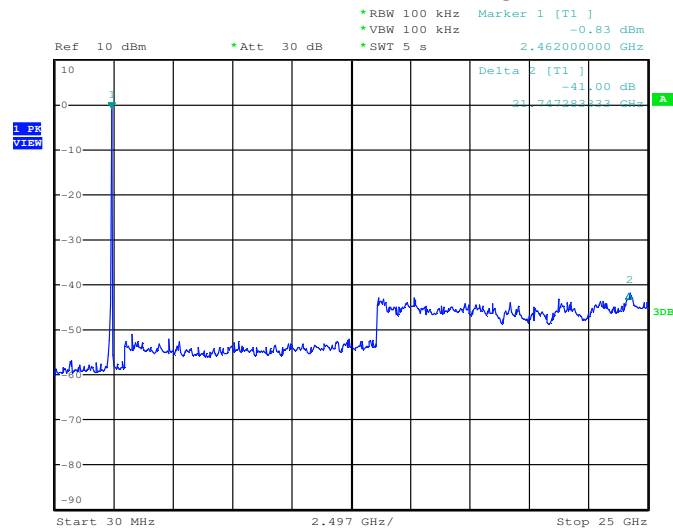

Date: 15.MAR.2011 03:54:35

Prüfbericht - Nr.: 16030075 001  
Test Report no.

Seite 35 von 37  
Page 35 of 37

Out of band conducted emission(802.11n HT20 2412MHz)

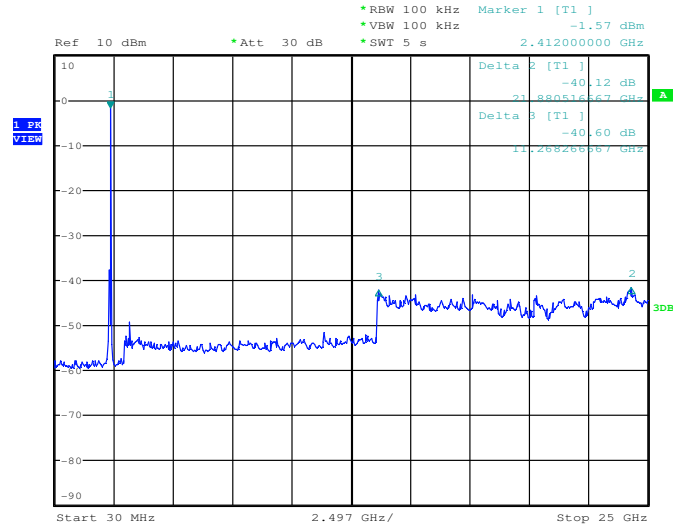

Date: 15.MAR.2011 03:56:24

Out of band conducted emission(802.11n HT20 2437MHz)

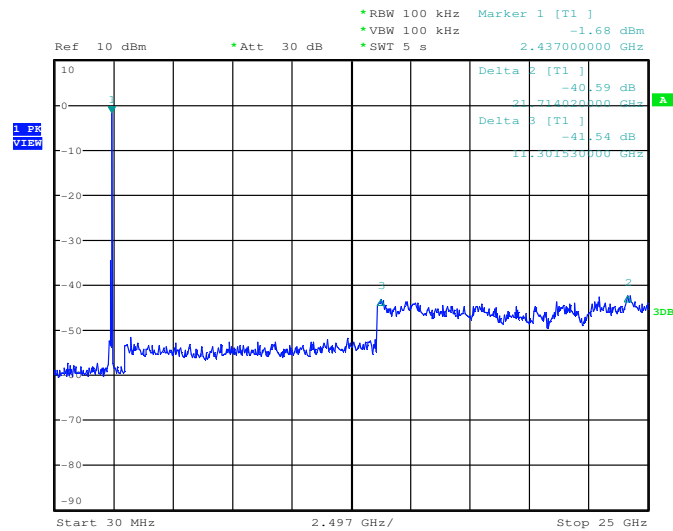

Date: 15.MAR.2011 04:02:05

Prüfbericht - Nr.:

16030075 001

Seite 36 von 37

Test Report no.

Page 36 of 37

Out of band conducted emission(802.11n HT20 2462MHz)

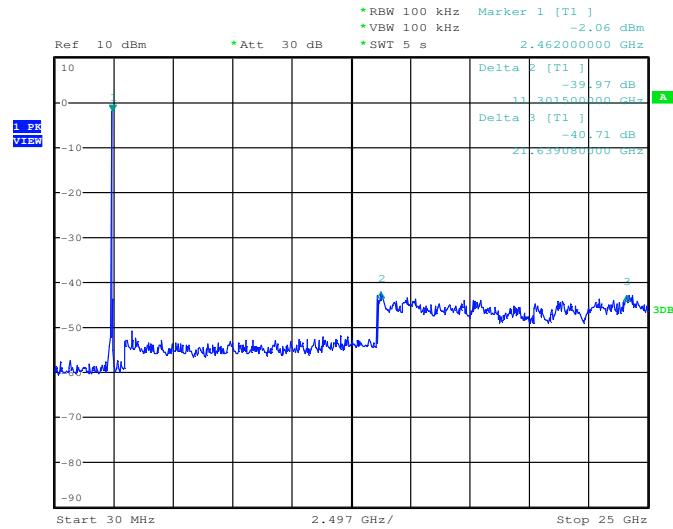

Date: 15.MAR.2011 04:03:39

Out of band conducted emission(802.11n HT40 2422MHz)

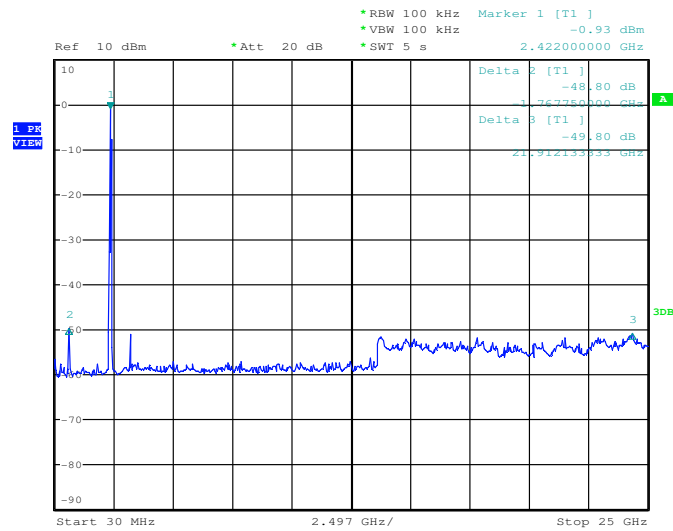

Date: 15.MAR.2011 03:32:05

Prüfbericht - Nr.:

16030075 001

Seite 37 von 37

Page 37 of 37

Test Report no.

Out of band conducted emission(802.11n HT40 2437MHz)

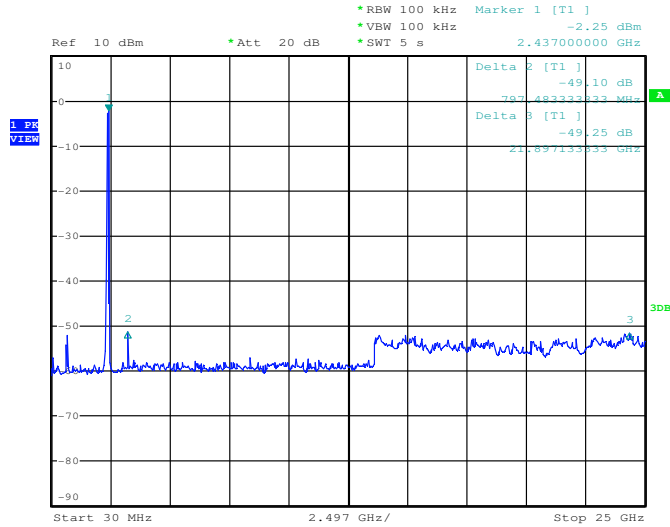

Date: 15.MAR.2011 03:34:51

Out of band conducted emission(802.11n HT40 2452MHz)

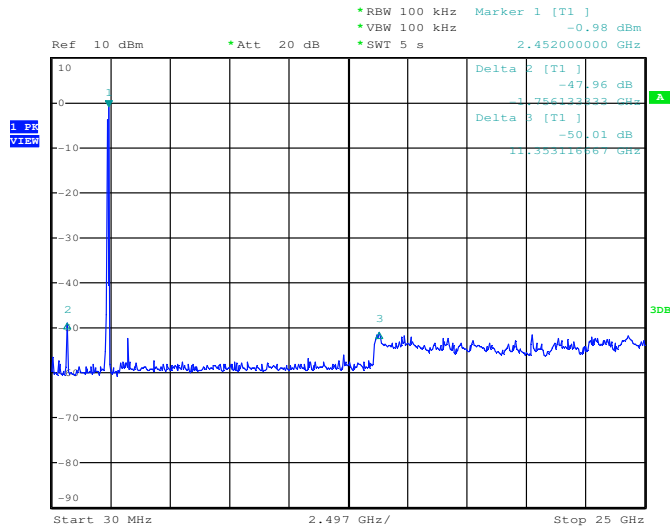

Date: 15.MAR.2011 03:36:36