



FCC RADIO TEST REPORT

FCC ID : XIA-NTC140
Equipment : LTE M2M Router
4G M2M Router
Brand Name : Netcomm Wireless
Model Name : NTC-140-01
Applicant : NetComm Wireless Limited
18-20 Orion Road Lane Cove, NSW 2066 Australia
Manufacturer : NetComm Wireless Limited
18-20 Orion Road Lane Cove, NSW 2066 Australia
Standard : 47 CFR Part 2, 22(H), 24(E)

The product was received on May 23, 2018 and testing was started from Jun. 05, 2018 and completed on Jun. 30, 2018. We, SPORTON INTERNATIONAL INC., would like to declare that the tested sample has been evaluated in accordance with the test procedures given in ANSI / TIA-603-E and has been in compliance with the applicable technical standards.

The report must not be used by the client to claim product certification, approval, or endorsement by TAF or any agency of government.

The test results in this report apply exclusively to the tested model / sample. Without written approval of SPORTON INTERNATIONAL INC. EMC & Wireless Communications Laboratory, the test report shall not be reproduced except in full.

Approved by: Jones Tsai

SPORTON INTERNATIONAL INC. EMC & Wireless Communications Laboratory

No. 52, Huaya 1st Rd., Guishan Dist., Taoyuan City, Taiwan (R.O.C.)



Table of Contents

History of this test report.....	3
Summary of Test Result.....	4
1 General Description	5
1.1 Product Feature of Equipment Under Test	5
1.2 Modification of EUT	5
1.3 Testing Location	5
1.4 Applicable Standards	6
2 Test Configuration of Equipment Under Test	7
2.1 Test Mode.....	7
2.2 Connection Diagram of Test System	7
2.3 Support Unit used in test configuration	8
2.4 Measurement Results Explanation Example	8
2.5 Frequency List of Low/Middle/High Channels.....	8
3 Conducted Test Result	9
3.1 Measuring Instruments.....	9
3.2 Conducted Output Power and ERP/EIRP	10
3.3 Peak-to-Average Ratio	11
3.4 99% Occupied Bandwidth and 26dB Bandwidth Measurement.....	12
3.5 Conducted Band Edge	13
3.6 Conducted Spurious Emission	14
3.7 Frequency Stability.....	15
4 Radiated Test Items	16
4.1 Measuring Instruments.....	16
4.2 Test Setup	16
4.3 Test Result of Radiated Test.....	16
4.4 Field Strength of Spurious Radiation Measurement	17
5 List of Measuring Equipment.....	18
6 Uncertainty of Evaluation	20
Appendix A. Test Results of Conducted Test	
Appendix B. Test Results of ERP/EIRP and Radiated Test	
Appendix C. Test Setup Photographs	



History of this test report

Report No.	Version	Description	Issued Date
FG441109-04A	01	Initial issue of report	Jul. 18, 2018



Summary of Test Result

Report Clause	Ref Std. Clause	Test Items	Result (PASS/FAIL)	Remark
3.2	§2.1046	Conducted Output Power	Pass	-
	§22.913 (a)(2)	Effective Radiated Power		
	§24.232 (c)	Equivalent Isotropic Radiated Power		
3.3	§24.232 (d)	Peak-to-Average Ratio	Pass	-
3.4	§2.1049 §22.917 (b) §24.238 (b)	Occupied Bandwidth	Pass	-
3.5	§2.1051 §22.917 (a) §24.238 (a)	Band Edge Measurement	Pass	-
3.6	§2.1051 §22.917 (a) §24.238 (a)	Conducted Emission	Pass	-
3.7	§2.1055 §22.355	Frequency Stability Temperature & Voltage	Pass	-
	§2.1055 §24.235			-
4.4	§2.1053 §22.917 (a) §24.238 (a)	Field Strength of Spurious Radiation	Pass	Under limit 27.68 dB at 5555.000 MHz

Reviewed by: Joseph Lin

Report Producer: Polly Tsai



1 General Description

1.1 Product Feature of Equipment Under Test

GSM/CDMA/WCDMA/LTE

Product Specification subjective to this standard	
Sample 1	EUT with Antenna 1 (ANT-0050)
Sample 2	EUT with Antenna 2 (ANT-0024)
Antenna Type	WWAN: Dipole Antenna

Remark: All test items were performed with Sample 1.

1.2 Modification of EUT

No modifications are made to the EUT during all test items.

1.3 Testing Location

Sporton Lab is accredited to ISO 17025 by Taiwan Accreditation Foundation (TAF code : 1190) and the FCC designation No. TW1190 and TW0007 under the FCC 2.948(e) by Mutual Recognition Agreement (MRA) in FCC Test.

Test Site	SPORTON INTERNATIONAL INC.
Test Site Location	No.52, Huaya 1st Rd., Guishan Dist., Taoyuan City, Taiwan (R.O.C.) TEL: +886-3-327-3456 FAX: +886-3-328-4978
Test Site No.	Sporton Site No. TH03-HY

Note: The test site complies with ANSI C63.4 2014 requirement.

Test Site	SPORTON INTERNATIONAL INC.
Test Site Location	No.58, Aly. 75, Ln. 564, Wenhua 3rd, Rd., Guishan Dist., Taoyuan City, Taiwan (R.O.C.) TEL: +886-3-327-0868 FAX: +886-3-327-0855
Test Site No.	Sporton Site No. 03CH12-HY

Note: The test site complies with ANSI C63.4 2014 requirement.



1.4 Applicable Standards

According to the specifications of the manufacturer, the EUT must comply with the requirements of the following standards:

- ♦ ANSI C63.26-2015
- ♦ ANSI / TIA-603-E
- ♦ 47 CFR Part 2, 22(H), 24(E), 27(L)
- ♦ FCC KDB 971168 D01 Power Meas. License Digital Systems v03r01
- ♦ FCC KDB 412172 D01 Determining ERP and EIRP v01r01

Remark:

1. All test items were verified and recorded according to the standards and without any deviation during the test.
2. This EUT has also been tested and complied with the requirements of FCC Part 15, Subpart B, recorded in a separate test report.

2 Test Configuration of Equipment Under Test

2.1 Test Mode

Antenna port conducted and radiated test items were performed according to KDB 971168 D01 Power Meas. License Digital Systems v03r01 with maximum output power.

For radiated measurement, pre-scanned in three orthogonal panels, X, Y, Z. The worst cases (X plane) were recorded in this report.

Radiated emissions were investigated as following frequency range:

1. 30 MHz to 9000 MHz for CDMA BC0.
2. 30 MHz to 19100 MHz for CDMA BC1.

All modes and data rates and positions were investigated.

Test modes are chosen to be reported as the worst case configuration below:

Test Modes		
Band	Radiated TCs	Conducted TCs
CDMA BC0	■ 1xEV-DO Rev. 0 Link	■ 1xEV-DO Rev. 0 Link
CDMA BC1	■ 1xEV-DO Rev. 0 Link	■ 1xEV-DO Rev. 0 Link

2.2 Connection Diagram of Test System

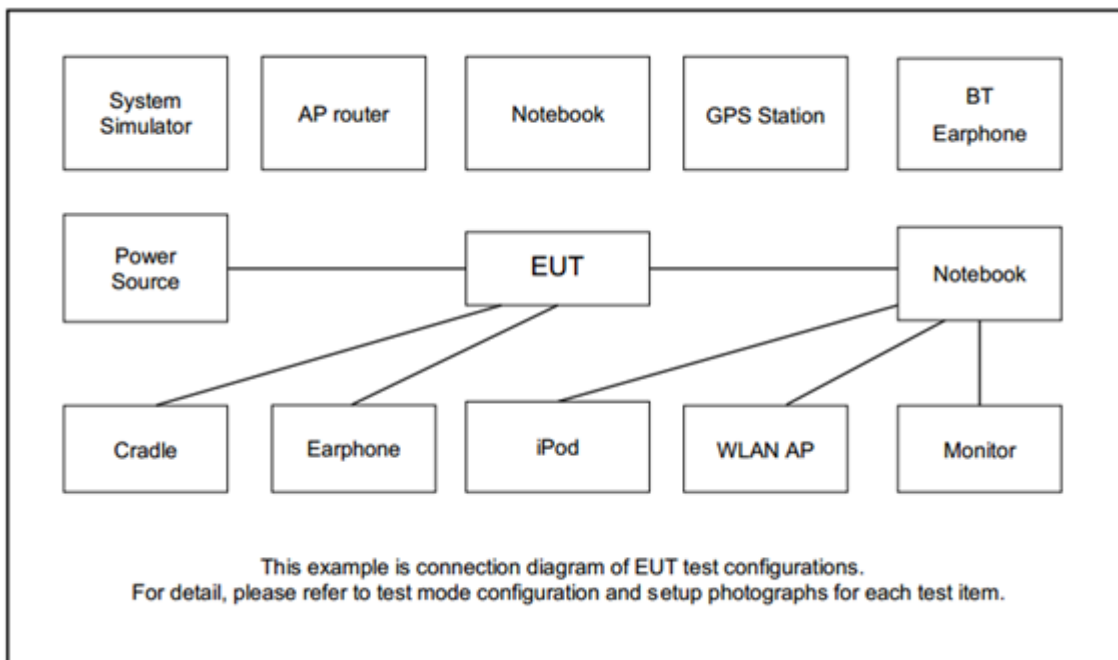



2.3 Support Unit used in test configuration

Item	Equipment	Trade Name	Model No.	FCC ID	Data Cable	Power Cord
1.	System Simulator	R&S	CMU 200	N/A	N/A	Unshielded, 1.8 m

2.4 Measurement Results Explanation Example

For all conducted test items:

The offset level is set in the spectrum analyzer to compensate the RF cable loss and attenuator factor between RF conducted output port and spectrum analyzer. With the offset compensation, the spectrum analyzer reading level will be exactly the RF output level.

The spectrum analyzer offset is derived from RF cable loss and attenuator factor.

$$\text{Offset} = \text{RF cable loss} + \text{attenuator factor}.$$

The following shows an offset computation example with RF cable loss 4.2 dB and a 10dB attenuator.

Example:

$$\begin{aligned} \text{Offset(dB)} &= \text{RF cable loss(dB)} + \text{attenuator factor(dB)}. \\ &= 4.2 + 10 = 14.2 \text{ (dB)} \end{aligned}$$

2.5 Frequency List of Low/Middle/High Channels

Frequency List				
Band	Channel/Frequency(MHz)	Lowest	Middle	Highest
CDMA2000 BC0	Channel	1013	384	777
	Frequency	824.7	836.52	848.31
CDMA2000 BC1	Channel	25	600	1175
	Frequency	1851.25	1880.0	1908.75

3 Conducted Test Result

3.1 Measuring Instruments

See list of measuring instruments of this test report.

3.1.1 Test Setup

3.1.2 Conducted Output Power

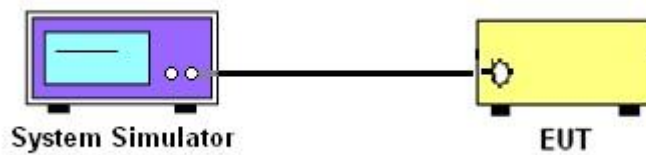

3.1.3 Peak-to-Average Ratio, Occupied Bandwidth, Conducted Band-Edge and Conducted Spurious Emission

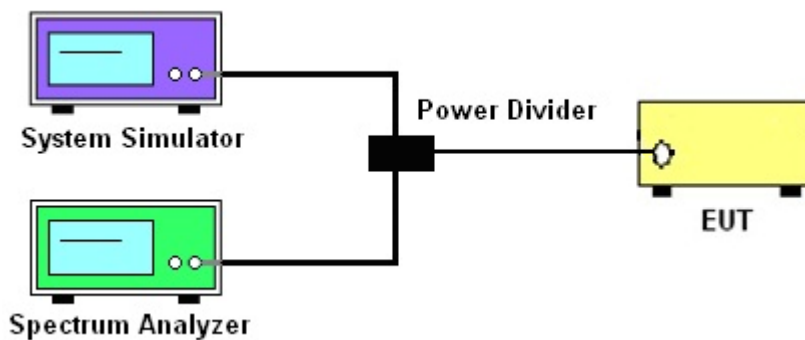

3.1.4 Frequency Stability

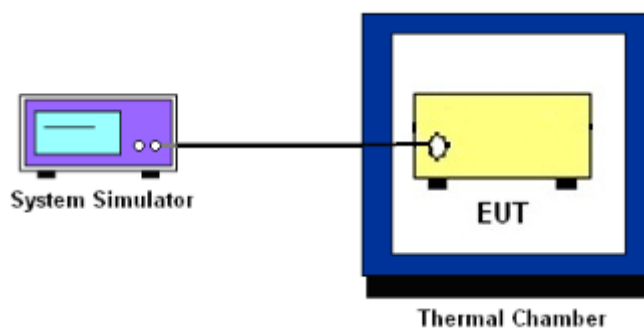

3.1.5 Test Result of Conducted Test

Please refer to Appendix A.



3.2 Conducted Output Power and ERP/EIRP

3.2.1 Description of the Conducted Output Power and ERP/EIRP

A system simulator was used to establish communication with the EUT. Its parameters were set to enforce EUT transmitting at the maximum power. The measured power in the radio frequency on the transmitter output terminals shall be reported.

The ERP of mobile transmitters must not exceed 7 Watts for CDMA BC0.

The EIRP of mobile transmitters must not exceed 2 Watts for CDMA BC1.

According to KDB 412172 D01 Power Approach,

$EIRP = P_T + G_T - L_C$, $ERP = EIRP - 2.15$, where

P_T = transmitter output power in dBm

G_T = gain of the transmitting antenna in dBi

L_C = signal attenuation in the connecting cable between the transmitter and antenna in dB

3.2.2 Test Procedures

1. The transmitter output port was connected to the system simulator.
2. Set EUT at maximum power through system simulator.
3. Select lowest, middle, and highest channels for each band and different modulation.
4. Measure the maximum burst average power for GSM and maximum average power for other modulation signal.



3.3 Peak-to-Average Ratio

3.3.1 Description of the PAR Measurement

The peak-to-average ratio (PAR) of the transmission may not exceed 13 dB.

3.3.2 Test Procedures

The testing follows FCC KDB 971168 D01 v03r01 Section 5.7.1

1. The EUT was connected to spectrum analyzer and system simulator via a power divider.
2. Set EUT to transmit at maximum output power.
3. When the duty cycle is less than 98%, then signal gating will be implemented on the spectrum analyzer by triggering from the system simulator.
4. Set the CCDF (Complementary Cumulative Distribution Function) option of the spectrum analyzer.
5. Record the maximum PAPR level associated with a probability of 0.1%.



3.4 99% Occupied Bandwidth and 26dB Bandwidth Measurement

3.4.1 Description of 99% Occupied Bandwidth and 26dB Bandwidth Measurement

The occupied bandwidth is the width of a frequency band such that, below the lower and above the upper frequency limits, the mean powers emitted are each equal to a specified percentage 0.5% of the total mean transmitted power.

The 26 dB emission bandwidth is defined as the frequency range between two points, one above and one below the carrier frequency, at which the spectral density of the emission is attenuated 26 dB below the maximum in-band spectral density of the modulated signal. Spectral density (power per unit bandwidth) is to be measured with a detector of resolution bandwidth equal to approximately 1.0% of the emission bandwidth.

3.4.2 Test Procedures

The testing follows FCC KDB 971168 D01 v03r01 Section 4.2

1. The EUT was connected to spectrum analyzer and system simulator via a power divider.
2. The spectrum analyzer center frequency is set to the nominal EUT channel center frequency. The span range for the spectrum analyzer shall be between two and five times the anticipated OBW.
3. The nominal resolution bandwidth (RBW) shall be in the range of 1 to 5 % of the anticipated OBW, and the VBW shall be at least 3 times the RBW.
4. Set the detection mode to peak, and the trace mode to max hold.
5. Determine the reference value: Set the EUT to transmit a modulated signal. Allow the trace to stabilize. Set the spectrum analyzer marker to the highest level of the displayed trace.
(this is the reference value)
6. Determine the “-26 dB down amplitude” as equal to (Reference Value – X).
7. Place two markers, one at the lowest and the other at the highest frequency of the envelope of the spectral display such that each marker is at or slightly below the “-X dB down amplitude” determined in step 6. If a marker is below this “-X dB down amplitude” value it shall be placed as close as possible to this value. The OBW is the positive frequency difference between the two markers.
8. Use the 99 % power bandwidth function of the spectrum analyzer and report the measured bandwidth.



3.5 Conducted Band Edge

3.5.1 Description of Conducted Band Edge Measurement

The power of any emission outside of the authorized operating frequency ranges must be lower than the transmitter power (P) by a factor of at least $43 + 10 \log (P)$ dB.

3.5.2 Test Procedures

The testing follows FCC KDB 971168 D01 v03r01 Section 6.0.

1. The EUT was connected to the spectrum analyzer and system simulator via a power divider.
2. The RF output of EUT was connected to the spectrum analyzer by an RF cable and attenuator. The path loss was compensated to the results for each measurement.
3. The band edges of low and high channels for the highest RF powers were measured.
4. The RF fundamental frequency should be excluded against the limit line in the operating frequency band.
5. The limit line is derived from $43 + 10\log(P)$ dB below the transmitter power P(Watts)



3.6 Conducted Spurious Emission

3.6.1 Description of Conducted Spurious Emission Measurement

The power of any emission outside of the authorized operating frequency ranges must be lower than the transmitter power (P) by a factor of at least $43 + 10 \log (P)$ dB.

It is measured by means of a calibrated spectrum analyzer and scanned from 30 MHz up to a frequency including its 10th harmonic.

3.6.2 Test Procedures

The testing follows FCC KDB 971168 D01 v03r01 Section 6.0.

1. The EUT was connected to the spectrum analyzer and system simulator via a power divider.
2. The RF output of EUT was connected to the spectrum analyzer by an RF cable and attenuator.
The path loss was compensated to the results for each measurement.
3. The middle channel for the highest RF power within the transmitting frequency was measured.
4. The conducted spurious emission for the whole frequency range was taken.
5. The RF fundamental frequency should be excluded against the limit line in the operating frequency band.
6. The limit line is derived from $43 + 10\log(P)$ dB below the transmitter power P(Watts)



3.7 Frequency Stability

3.7.1 Description of Frequency Stability Measurement

22.355

The frequency stability shall be measured by variation of ambient temperature and variation of primary supply voltage to ensure that the fundamental emission stays within the authorized frequency block. The frequency stability of the transmitter shall be maintained within $\pm 0.00025\%$ ($\pm 2.5\text{ppm}$) of the center frequency.

24.235

The frequency stability shall be sufficient to ensure that the fundamental emission stays within the authorized frequency block.

3.7.2 Test Procedures for Temperature Variation

The testing follows FCC KDB 971168 D01 v03r01 Section 9.0.

1. The EUT was set up in the thermal chamber and connected with the system simulator.
2. With power OFF, the temperature was decreased to -30°C and the EUT was stabilized before testing. Power was applied and the maximum change in frequency was recorded within one minute.
3. With power OFF, the temperature was raised in 10°C steps up to 50°C . The EUT was stabilized at each step for at least half an hour. Power was applied and the maximum frequency change was recorded within one minute.

3.7.3 Test Procedures for Voltage Variation

The testing follows FCC KDB 971168 D01 v03r01 Section 9.0.

1. The EUT was placed in a temperature chamber at $20\pm 5^{\circ}\text{C}$ and connected with the system simulator.
2. The power supply voltage to the EUT was varied from 85% to 115% of the nominal value measured at the input to the EUT.
3. The variation in frequency was measured for the worst case.

4 Radiated Test Items

4.1 Measuring Instruments

See list of measuring instruments of this test report.

4.2 Test Setup

For radiated test from 30MHz to 1GHz

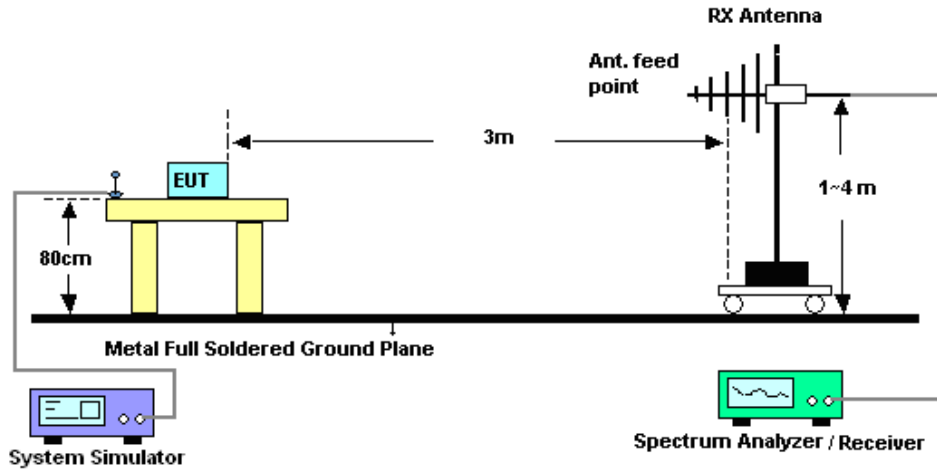

For radiated test above 1GHz

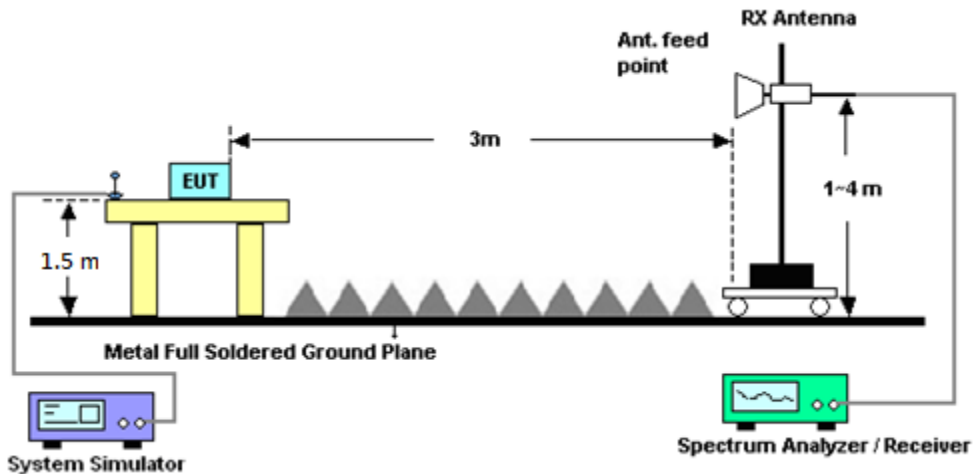

4.3 Test Result of Radiated Test

Please refer to Appendix B.



4.4 Field Strength of Spurious Radiation Measurement

4.4.1 Description of Field Strength of Spurious Radiated Measurement

The power of any emission outside of the authorized operating frequency ranges must be attenuated below the transmitter power (P) by a factor of at least $43 + 10 \log (P)$ dB. The spectrum is scanned from 30 MHz up to a frequency including its 10th harmonic.

4.4.2 Test Procedures

The testing follows FCC KDB 971168 D01 v03r01 Section 5.8 and ANSI / TIA-603-E Section 2.2.12.

1. The EUT was placed on a rotatable wooden table 0.8 meters for frequency below 1GHz and 1.5 meter for frequency above 1GHz above the ground.
2. The EUT was set 3 meters from the receiving antenna, which was mounted on the antenna tower.
3. The table was rotated 360 degrees to determine the position of the highest spurious emission.
4. The height of the receiving antenna is varied between one meter and four meters to search for the maximum spurious emission for both horizontal and vertical polarizations.
5. Make the measurement with the spectrum analyzer's RBW = 1MHz, VBW = 3MHz, taking record of maximum spurious emission.
6. A horn antenna was substituted in place of the EUT and was driven by a signal generator.
7. Tune the output power of signal generator to the same emission level with EUT maximum spurious emission.
8. Taking the record of output power at antenna port.
9. Repeat step 7 to step 8 for another polarization.
10. $EIRP (dBm) = S.G. Power - Tx Cable Loss + Tx Antenna Gain$
11. $ERP (dBm) = EIRP - 2.15$
12. The RF fundamental frequency should be excluded against the limit line in the operating frequency band.
13. The limit line is derived from $43 + 10\log(P)$ dB below the transmitter power P(Watts)



5 List of Measuring Equipment

Instrument	Manufacturer	Model No.	Serial No.	Characteristics	Calibration Date	Test Date	Due Date	Remark
Spectrum Analyzer	Rohde & Schwarz	FSP30	101329	9kHz~30GHz	Jun. 26, 2017	Jun. 05, 2018~ Jun. 06, 2018	Jun. 25, 2018	Conducted (TH03-HY)
Temperature Chamber	ESPEC	SU-641	92013721	-30℃ ~70℃	Dec. 06, 2017	Jun. 05, 2018~ Jun. 06, 2018	Dec. 05, 2019	Conducted (TH03-HY)
Programmable Power Supply	GW Instek	PSS-2005	EL883644	Voltage:0~20V; Current:0~5A	Dec. 06, 2017	Jun. 05, 2018~ Jun. 06, 2018	Dec. 05, 2019	Conducted (TH03-HY)
Base Station (Measure)	Rohde & Schwarz	CMU200	117995	GSM / GPRS / WCDMA / CDMA	Aug. 09, 2017	Jun. 05, 2018~ Jun. 06, 2018	Aug. 08, 2018	Conducted (TH03-HY)
Loop Antenna	Rohde & Schwarz	HFH2-Z2	100488	9 kHz~30 MHz	Nov. 23, 2017	Jun. 27, 2018~ Jun. 30, 2018	Nov. 22, 2018	Radiation (03CH12-HY)
Bilog Antenna	TESEQ	CBL 6111D&00800 N1D01N-06	37059&01	30MHz~1GHz	Oct. 14, 2017	Jun. 27, 2018~ Jun. 30, 2018	Oct. 13, 2018	Radiation (03CH12-HY)
Horn Antenna	SCHWARZBECK	BBHA 9120D	9120D-132 8	1GHz ~ 18GHz	Oct. 20, 2017	Jun. 27, 2018~ Jun. 30, 2018	Oct. 19, 2018	Radiation (03CH12-HY)
SHF-EHF Horn Antenna	SCHWARZBECK	BBHA 9170	BBHA9170 584	18GHz ~ 40GHz	Nov. 27, 2017	Jun. 27, 2018~ Jun. 30, 2018	Nov. 26, 2018	Radiation (03CH12-HY)
Preamplifier	COM-POWER	PA-103	161075	10MHz~1GHz	Mar. 26, 2018	Jun. 27, 2018~ Jun. 30, 2018	Mar. 25, 2019	Radiation (03CH12-HY)
Preamplifier	Keysight	83017A	MY532701 48	1GHz~26.5GHz	Jan. 15, 2018	Jun. 27, 2018~ Jun. 30, 2018	Jan. 14, 2019	Radiation (03CH12-HY)
Amplifier	MITEQ	TTA1840-35- HG	1871923	18GHz~40GHz, VSWR : 2.5:1 max	Jul. 18, 2017	Jun. 27, 2018~ Jun. 30, 2018	Jul. 17, 2018	Radiation (03CH12-HY)
EMI Test Receiver	Rohde & Schwarz	ESU26	100390	20Hz~26.5GHz	Dec. 25, 2017	Jun. 27, 2018~ Jun. 30, 2018	Dec. 24, 2018	Radiation (03CH12-HY)
Horn Antenna	SCHWARZBECK	BBHA 9120D	9120D-152 2	1GHz ~ 18GHz	May. 10, 2018	Jun. 27, 2018~ Jun. 30, 2018	May. 09, 2019	Radiation (03CH12-HY)
Signal Generator	Rohde & Schwarz	SMF100A	101107	100kHz~40GHz	May. 21, 2018	Jun. 27, 2018~ Jun. 30, 2018	May. 20, 2019	Radiation (03CH12-HY)
Base Station	Rohde & Schwarz	CMU200	106656	GSM/GPRS/WC DMA/CDMA	Nov. 15, 2016	Jun. 27, 2018~ Jun. 30, 2018	Nov. 14, 2018	Radiation (03CH12-HY)
Filter	Wainwright	WLKS1200-1 2SS	SN2	1.2G Low Pass	Jul. 17, 2017	Jun. 27, 2018~ Jun. 30, 2018	Jul. 16, 2018	Radiation (03CH12-HY)
Notch Filter	Wainwright	WRCD1800/2 000-20/40-10 SSK	SN1	LTE Band 25	Aug. 24, 2017	Jun. 27, 2018~ Jun. 30, 2018	Aug. 23, 2018	Radiation (03CH12-HY)
Notch Filter	Wainwright	WRCT/800/96 0-0.2/40-8SS K	SN11	GSM850	Aug. 24, 2017	Jun. 27, 2018~ Jun. 30, 2018	Aug. 23, 2018	Radiation (03CH12-HY)
RF Cable	HUBER + SUHNER	SUCOFLEX 126E	0058/126E	30M-18G	Mar. 14, 2018	Jun. 27, 2018~ Jun. 30, 2018	Mar. 13, 2019	Radiation (03CH12-HY)
RF Cable	HUBER + SUHNER	SUCOFLEX 102	505134/2	30M~40GHz	Oct. 17, 2017	Jun. 27, 2018~ Jun. 30, 2018	Oct. 16, 2018	Radiation (03CH12-HY)
RF Cable	HUBER + SUHNER	SUCOFLEX 102	800740/2	30M~40GHz	Oct. 17, 2017	Jun. 27, 2018~ Jun. 30, 2018	Oct. 16, 2018	Radiation (03CH12-HY)



Instrument	Manufacturer	Model No.	Serial No.	Characteristics	Calibration Date	Test Date	Due Date	Remark
Antenna Mast	EMEC	AM-BS-4500-B	N/A	1m~4m	N/A	Jun. 27, 2018~ Jun. 30, 2018	N/A	Radiation (03CH12-HY)
Turn Table	EMEC	TT2000	N/A	0~360 Degree	N/A	Jun. 27, 2018~ Jun. 30, 2018	N/A	Radiation (03CH12-HY)
Software	Audix	E3 6.2009-8-24	RK-00098 9	N/A	N/A	Jun. 27, 2018~ Jun. 30, 2018	N/A	Radiation (03CH12-HY)



6 Uncertainty of Evaluation

Uncertainty of Radiated Emission Measurement (30 MHz ~ 1000 MHz)

Measuring Uncertainty for a Level of Confidence of 95% ($U = 2Uc(y)$)	3.36
---	------

Uncertainty of Radiated Emission Measurement (1 GHz ~ 18 GHz)

Measuring Uncertainty for a Level of Confidence of 95% ($U = 2Uc(y)$)	3.70
---	------

Uncertainty of Radiated Emission Measurement (18 GHz ~ 40 GHz)

Measuring Uncertainty for a Level of Confidence of 95% ($U = 2Uc(y)$)	3.98
---	------



Appendix A. Test Results of Conducted Test

Conducted Output Power(Average power)

Conducted Power (*Unit: dBm)						
Band	CDMA 2000 BC0			CDMA 2000 BC1		
Channel	1013	384	777	25	600	1175
Frequency	824.7	836.52	848.31	1851.25	1880	1908.75
1xRTT RC1 SO55	23.55	23.60	23.52	23.82	23.76	23.85
1xRTT RC3 SO55	23.51	23.57	23.50	23.79	23.72	23.84
1xRTT RC3 SO32 (+ F-SCH)	23.52	23.58	23.53	23.78	23.69	23.81
1xRTT RC3 SO32 (+SCH)	23.53	23.55	23.57	23.80	23.72	23.80
1xEVDO RTAP 153.6Kbps	23.56	23.61	23.58	23.85	23.77	23.86
1xEVDO RETAP 4096Bits	23.54	23.59	23.56	23.82	23.75	23.84



A2. CDMA

Peak-to-Average Ratio

Mode	CDMA BC0	CDMA BC1	Limit: 13dB
Mod.	1xEV-DO Rev. 0	1xEV-DO Rev. 0	Result
Lowest CH	4.84	5.48	PASS
Middle CH	5.36	4.80	
Highest CH	4.64	4.32	

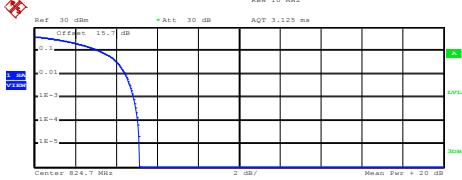
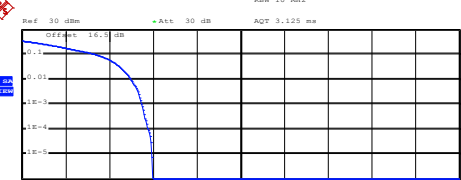
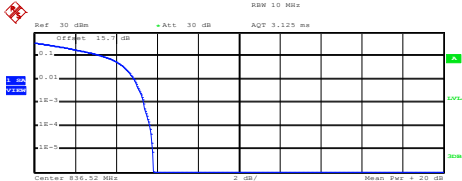
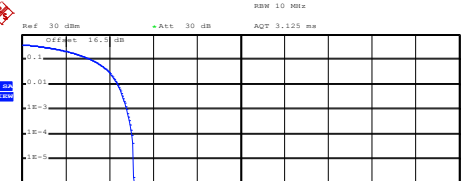
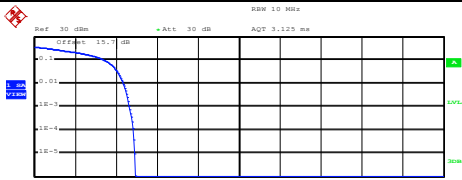
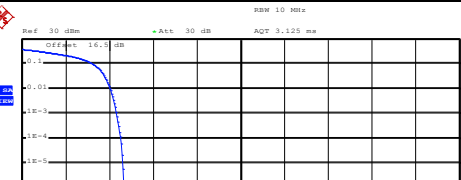

CDMA BC0 (1xEV-DO Rev. 0)	CDMA BC1 (1xEV-DO Rev. 0)
<p align="center">Lowest Channel</p>  <p>Center 824.7 MHz</p> <p>Complementary Cumulative Distribution Function (100000 samples)</p> <p>Trace 1</p> <p>Mean 23.29 dBm Peak 28.42 dBm Crest 5.13 dB</p> <p>10 % 3.24 dB 1 % 4.44 dB .1 % 4.84 dB .01 % 5.08 dB</p> <p>Date: 6.JUN.2018 17:58:35</p>	<p align="center">Lowest Channel</p>  <p>Center 1.83125 GHz</p> <p>Complementary Cumulative Distribution Function (100000 samples)</p> <p>Trace 1</p> <p>Mean 22.10 dBm Peak 28.07 dBm Crest 5.96 dB</p> <p>10 % 3.48 dB 1 % 5.00 dB .1 % 5.48 dB .01 % 5.80 dB</p> <p>Date: 6.JUN.2018 18:24:18</p>
<p align="center">Middle Channel</p>  <p>Center 836.52 MHz</p> <p>Complementary Cumulative Distribution Function (100000 samples)</p> <p>Trace 1</p> <p>Mean 23.31 dBm Peak 29.13 dBm Crest 5.82 dB</p> <p>10 % 3.40 dB 1 % 4.88 dB .1 % 5.36 dB .01 % 5.64 dB</p> <p>Date: 6.JUN.2018 17:58:51</p>	<p align="center">Middle Channel</p>  <p>Center 1.88 GHz</p> <p>Complementary Cumulative Distribution Function (100000 samples)</p> <p>Trace 1</p> <p>Mean 23.03 dBm Peak 28.14 dBm Crest 5.11 dB</p> <p>10 % 3.20 dB 1 % 4.40 dB .1 % 4.80 dB .01 % 5.04 dB</p> <p>Date: 6.JUN.2018 18:24:31</p>
<p align="center">Highest Channel</p>  <p>Center 848.31 MHz</p> <p>Complementary Cumulative Distribution Function (100000 samples)</p> <p>Trace 1</p> <p>Mean 23.21 dBm Peak 28.14 dBm Crest 4.92 dB</p> <p>10 % 3.48 dB 1 % 4.36 dB .1 % 4.64 dB .01 % 4.84 dB</p> <p>Date: 6.JUN.2018 17:59:06</p>	<p align="center">Highest Channel</p>  <p>Center 1.90875 GHz</p> <p>Complementary Cumulative Distribution Function (100000 samples)</p> <p>Trace 1</p> <p>Mean 23.04 dBm Peak 27.71 dBm Crest 4.67 dB</p> <p>10 % 3.28 dB 1 % 4.04 dB .1 % 4.32 dB .01 % 4.52 dB</p> <p>Date: 6.JUN.2018 18:24:44</p>



26dB Bandwidth

Mode	CDMA BC0	CDMA BC1
Mod.	1xEV-DO Rev. 0	1xEV-DO Rev. 0
Lowest CH	1.43	1.43
Middle CH	1.43	1.43
Highest CH	1.43	1.44



CDMA BC0 (1xEV-DO Rev. 0)

CDMA BC1 (1xEV-DO Rev. 0)

Lowest Channel

Lowest Channel

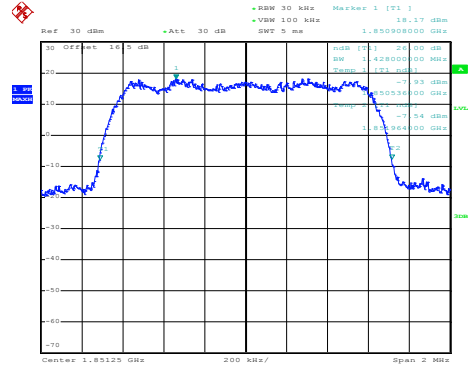
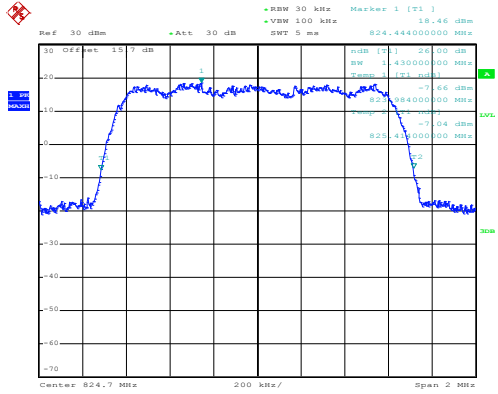

Date: 6.JUN.2018 17:45:03

Date: 6.JUN.2018 18:11:24

Middle Channel

Middle Channel

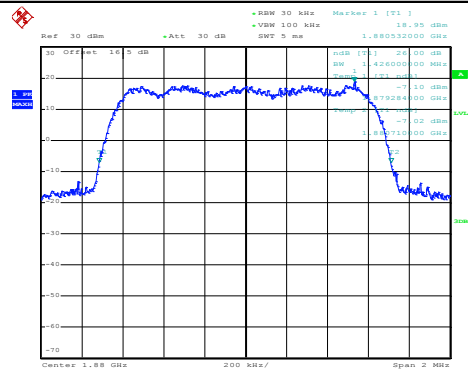
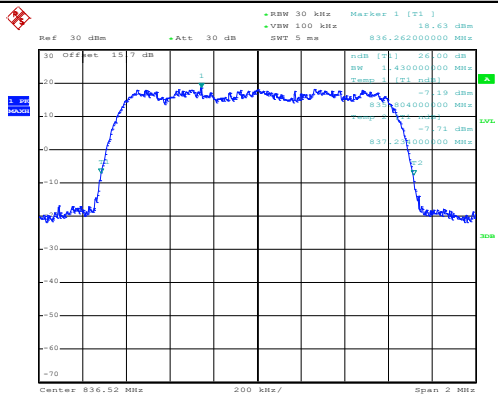

Date: 6.JUN.2018 17:45:36

Date: 6.JUN.2018 18:11:57

Highest Channel

Highest Channel

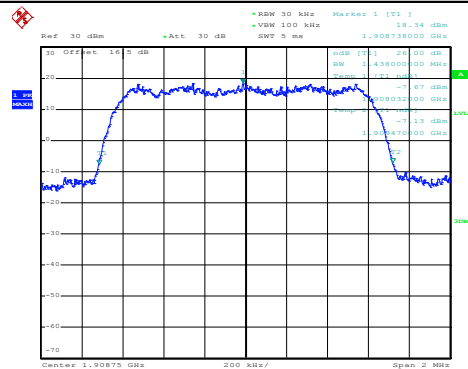
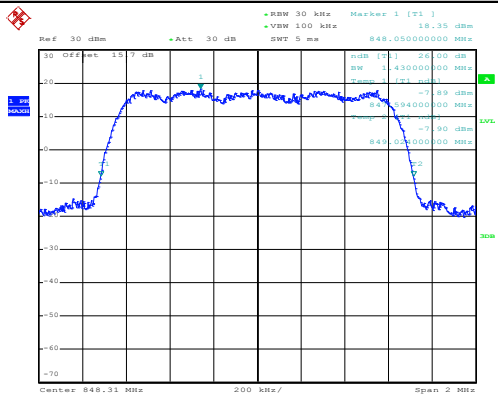

Date: 6.JUN.2018 17:46:24

Date: 6.JUN.2018 18:12:49



Occupied Bandwidth

Mode	CDMA BC0	CDMA BC1
Mod.	1xEV-DO Rev. 0	1xEV-DO Rev. 0
Lowest CH	1.27	1.27
Middle CH	1.27	1.27
Highest CH	1.27	1.28

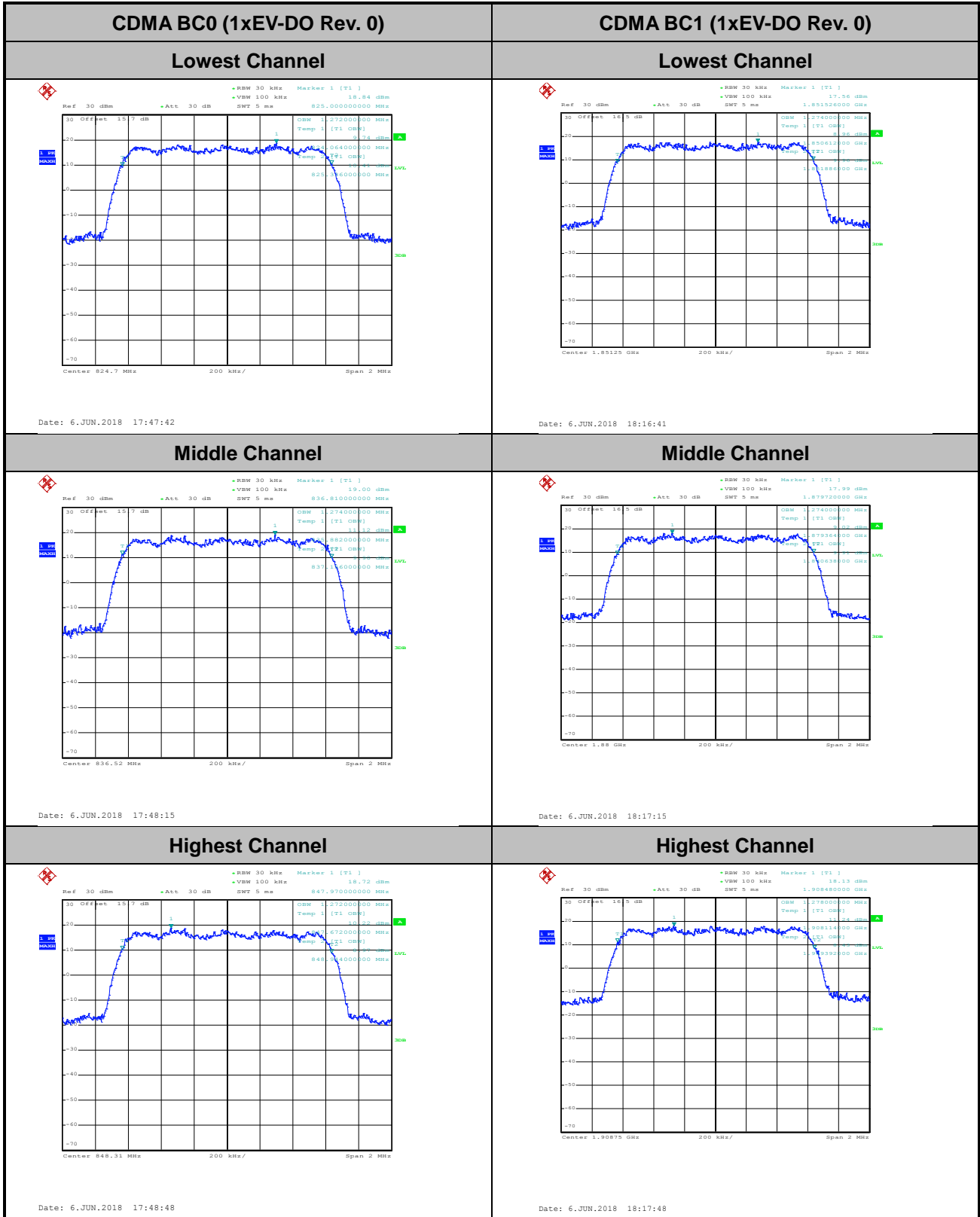



Conducted Band Edge



CDMA BC0 (1xEV-DO Rev. 0)

Lowest Band Edge

Highest Band Edge

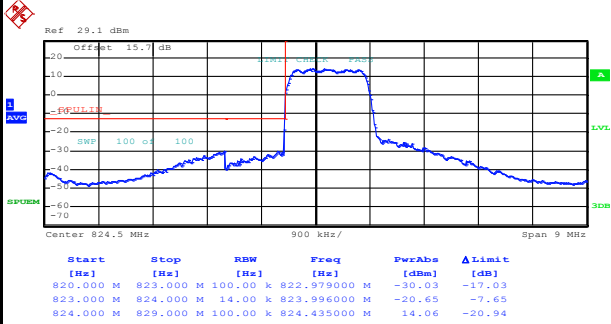

Date: 6.JUN.2018 17:51:37

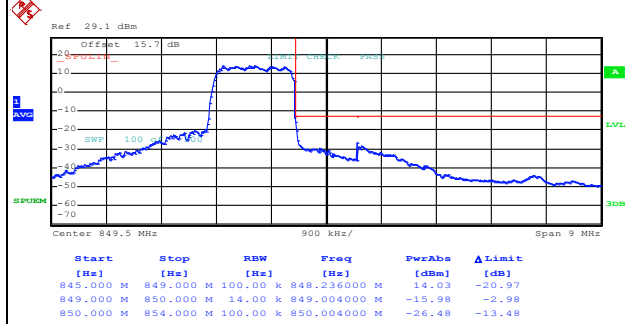

Date: 6.JUN.2018 17:54:24



CDMA BC1 (1xEV-DO Rev. 0)

Lowest Band Edge

Highest Band Edge

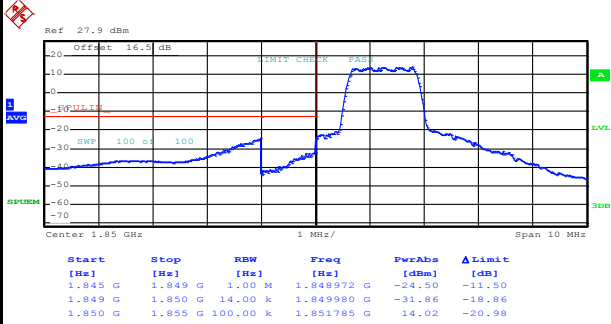

Date: 6.JUN.2018 18:20:39

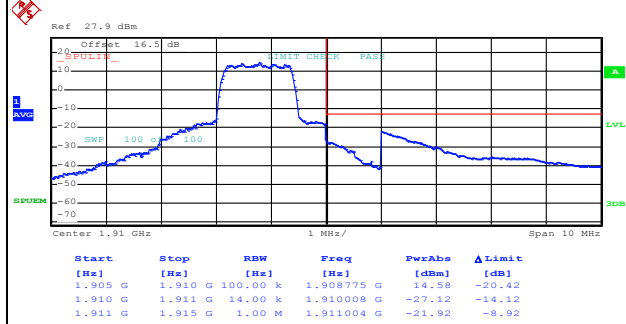

Date: 6.JUN.2018 18:23:55



Conducted Spurious Emission

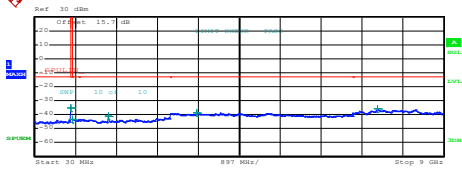
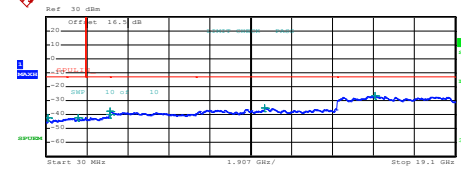
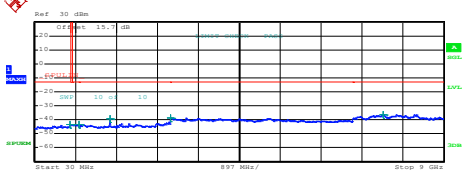
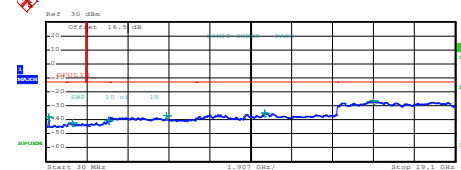
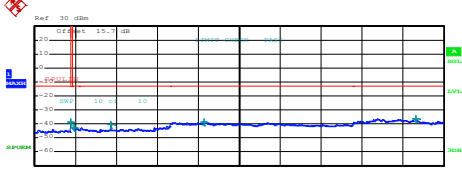
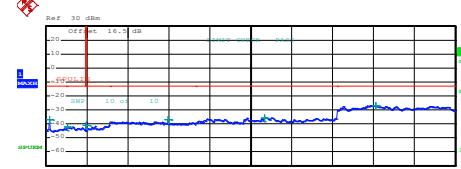

CDMA BC0 (1xEV-DO Rev. 0)	CDMA BC1 (1xEV-DO Rev. 0)																																																																														
Lowest Channel	Lowest Channel																																																																														
 <table border="1" data-bbox="239 571 638 660"> <thead> <tr> <th>Start [Hz]</th> <th>Stop [Hz]</th> <th>RBW [Hz]</th> <th>Freq [Hz]</th> <th>PwrAbs [dBm]</th> <th>ΔLimit [dB]</th> </tr> </thead> <tbody> <tr><td>30,000 M</td><td>820,000 M</td><td>1,000 M</td><td>810,000000 M</td><td>-35.150</td><td>-22.10</td></tr> <tr><td>855,000 M</td><td>1,000 G</td><td>1,000 G</td><td>856,993750 M</td><td>-43.50</td><td>-30.50</td></tr> <tr><td>1,000 G</td><td>3,000 G</td><td>1,000 M</td><td>1,0000000 G</td><td>-42.24</td><td>-28.24</td></tr> <tr><td>3,000 G</td><td>7,000 G</td><td>1,000 M</td><td>3,588000 G</td><td>-38.53</td><td>-25.53</td></tr> <tr><td>7,000 G</td><td>9,000 G</td><td>1,000 M</td><td>7,543500 G</td><td>-36.03</td><td>-23.03</td></tr> </tbody> </table> <p>Date: 6.JUN.2018 17:56:25</p>	Start [Hz]	Stop [Hz]	RBW [Hz]	Freq [Hz]	PwrAbs [dBm]	ΔLimit [dB]	30,000 M	820,000 M	1,000 M	810,000000 M	-35.150	-22.10	855,000 M	1,000 G	1,000 G	856,993750 M	-43.50	-30.50	1,000 G	3,000 G	1,000 M	1,0000000 G	-42.24	-28.24	3,000 G	7,000 G	1,000 M	3,588000 G	-38.53	-25.53	7,000 G	9,000 G	1,000 M	7,543500 G	-36.03	-23.03	 <table border="1" data-bbox="877 571 1276 660"> <thead> <tr> <th>Start [Hz]</th> <th>Stop [Hz]</th> <th>RBW [Hz]</th> <th>Freq [Hz]</th> <th>PwrAbs [dBm]</th> <th>ΔLimit [dB]</th> </tr> </thead> <tbody> <tr><td>30,000 M</td><td>1,000 G</td><td>1,000 M</td><td>133,137800 M</td><td>-41.97</td><td>-28.97</td></tr> <tr><td>1,000 G</td><td>1,845 G</td><td>1,000 M</td><td>1,502254 G</td><td>-42.24</td><td>-29.24</td></tr> <tr><td>1,845 G</td><td>3,000 G</td><td>1,000 M</td><td>2,988879 G</td><td>-40.11</td><td>-27.11</td></tr> <tr><td>3,000 G</td><td>7,000 G</td><td>1,000 M</td><td>3,004000 G</td><td>-37.32</td><td>-24.32</td></tr> <tr><td>7,000 G</td><td>13,600 G</td><td>1,000 M</td><td>10,235025 G</td><td>-35.17</td><td>-22.17</td></tr> <tr><td>13,600 G</td><td>19,100 G</td><td>1,000 M</td><td>15,366875 G</td><td>-26.67</td><td>-13.67</td></tr> </tbody> </table> <p>Date: 6.JUN.2018 18:14:15</p>	Start [Hz]	Stop [Hz]	RBW [Hz]	Freq [Hz]	PwrAbs [dBm]	ΔLimit [dB]	30,000 M	1,000 G	1,000 M	133,137800 M	-41.97	-28.97	1,000 G	1,845 G	1,000 M	1,502254 G	-42.24	-29.24	1,845 G	3,000 G	1,000 M	2,988879 G	-40.11	-27.11	3,000 G	7,000 G	1,000 M	3,004000 G	-37.32	-24.32	7,000 G	13,600 G	1,000 M	10,235025 G	-35.17	-22.17	13,600 G	19,100 G	1,000 M	15,366875 G	-26.67	-13.67
Start [Hz]	Stop [Hz]	RBW [Hz]	Freq [Hz]	PwrAbs [dBm]	ΔLimit [dB]																																																																										
30,000 M	820,000 M	1,000 M	810,000000 M	-35.150	-22.10																																																																										
855,000 M	1,000 G	1,000 G	856,993750 M	-43.50	-30.50																																																																										
1,000 G	3,000 G	1,000 M	1,0000000 G	-42.24	-28.24																																																																										
3,000 G	7,000 G	1,000 M	3,588000 G	-38.53	-25.53																																																																										
7,000 G	9,000 G	1,000 M	7,543500 G	-36.03	-23.03																																																																										
Start [Hz]	Stop [Hz]	RBW [Hz]	Freq [Hz]	PwrAbs [dBm]	ΔLimit [dB]																																																																										
30,000 M	1,000 G	1,000 M	133,137800 M	-41.97	-28.97																																																																										
1,000 G	1,845 G	1,000 M	1,502254 G	-42.24	-29.24																																																																										
1,845 G	3,000 G	1,000 M	2,988879 G	-40.11	-27.11																																																																										
3,000 G	7,000 G	1,000 M	3,004000 G	-37.32	-24.32																																																																										
7,000 G	13,600 G	1,000 M	10,235025 G	-35.17	-22.17																																																																										
13,600 G	19,100 G	1,000 M	15,366875 G	-26.67	-13.67																																																																										
Middle Channel	Middle Channel																																																																														
 <table border="1" data-bbox="239 1086 638 1176"> <thead> <tr> <th>Start [Hz]</th> <th>Stop [Hz]</th> <th>RBW [Hz]</th> <th>Freq [Hz]</th> <th>PwrAbs [dBm]</th> <th>ΔLimit [dB]</th> </tr> </thead> <tbody> <tr><td>30,000 M</td><td>820,000 M</td><td>1,000 M</td><td>805,385000 M</td><td>-43.46</td><td>-30.46</td></tr> <tr><td>855,000 M</td><td>1,000 G</td><td>1,000 M</td><td>931,030000 M</td><td>-43.57</td><td>-30.57</td></tr> <tr><td>1,000 G</td><td>3,000 G</td><td>1,000 M</td><td>1,672500 G</td><td>-39.52</td><td>-26.52</td></tr> <tr><td>3,000 G</td><td>7,000 G</td><td>1,000 M</td><td>3,001000 G</td><td>-38.75</td><td>-25.75</td></tr> <tr><td>7,000 G</td><td>9,000 G</td><td>1,000 M</td><td>7,481500 G</td><td>-36.41</td><td>-23.41</td></tr> </tbody> </table> <p>Date: 6.JUN.2018 17:57:20</p>	Start [Hz]	Stop [Hz]	RBW [Hz]	Freq [Hz]	PwrAbs [dBm]	ΔLimit [dB]	30,000 M	820,000 M	1,000 M	805,385000 M	-43.46	-30.46	855,000 M	1,000 G	1,000 M	931,030000 M	-43.57	-30.57	1,000 G	3,000 G	1,000 M	1,672500 G	-39.52	-26.52	3,000 G	7,000 G	1,000 M	3,001000 G	-38.75	-25.75	7,000 G	9,000 G	1,000 M	7,481500 G	-36.41	-23.41	 <table border="1" data-bbox="877 1086 1276 1176"> <thead> <tr> <th>Start [Hz]</th> <th>Stop [Hz]</th> <th>RBW [Hz]</th> <th>Freq [Hz]</th> <th>PwrAbs [dBm]</th> <th>ΔLimit [dB]</th> </tr> </thead> <tbody> <tr><td>30,000 M</td><td>1,000 G</td><td>1,000 M</td><td>141,307500 M</td><td>-37.91</td><td>-24.91</td></tr> <tr><td>1,000 G</td><td>3,845 G</td><td>1,000 M</td><td>1,0003500 G</td><td>-42.56</td><td>-29.56</td></tr> <tr><td>1,915 G</td><td>3,000 G</td><td>1,000 M</td><td>2,937884 G</td><td>-40.58</td><td>-27.58</td></tr> <tr><td>3,000 G</td><td>7,000 G</td><td>1,000 M</td><td>5,640000 G</td><td>-36.83</td><td>-23.83</td></tr> <tr><td>7,000 G</td><td>13,600 G</td><td>1,000 M</td><td>10,229500 G</td><td>-35.17</td><td>-22.17</td></tr> <tr><td>13,600 G</td><td>19,100 G</td><td>1,000 M</td><td>15,298813 G</td><td>-26.57</td><td>-13.57</td></tr> </tbody> </table> <p>Date: 6.JUN.2018 18:15:05</p>	Start [Hz]	Stop [Hz]	RBW [Hz]	Freq [Hz]	PwrAbs [dBm]	ΔLimit [dB]	30,000 M	1,000 G	1,000 M	141,307500 M	-37.91	-24.91	1,000 G	3,845 G	1,000 M	1,0003500 G	-42.56	-29.56	1,915 G	3,000 G	1,000 M	2,937884 G	-40.58	-27.58	3,000 G	7,000 G	1,000 M	5,640000 G	-36.83	-23.83	7,000 G	13,600 G	1,000 M	10,229500 G	-35.17	-22.17	13,600 G	19,100 G	1,000 M	15,298813 G	-26.57	-13.57
Start [Hz]	Stop [Hz]	RBW [Hz]	Freq [Hz]	PwrAbs [dBm]	ΔLimit [dB]																																																																										
30,000 M	820,000 M	1,000 M	805,385000 M	-43.46	-30.46																																																																										
855,000 M	1,000 G	1,000 M	931,030000 M	-43.57	-30.57																																																																										
1,000 G	3,000 G	1,000 M	1,672500 G	-39.52	-26.52																																																																										
3,000 G	7,000 G	1,000 M	3,001000 G	-38.75	-25.75																																																																										
7,000 G	9,000 G	1,000 M	7,481500 G	-36.41	-23.41																																																																										
Start [Hz]	Stop [Hz]	RBW [Hz]	Freq [Hz]	PwrAbs [dBm]	ΔLimit [dB]																																																																										
30,000 M	1,000 G	1,000 M	141,307500 M	-37.91	-24.91																																																																										
1,000 G	3,845 G	1,000 M	1,0003500 G	-42.56	-29.56																																																																										
1,915 G	3,000 G	1,000 M	2,937884 G	-40.58	-27.58																																																																										
3,000 G	7,000 G	1,000 M	5,640000 G	-36.83	-23.83																																																																										
7,000 G	13,600 G	1,000 M	10,229500 G	-35.17	-22.17																																																																										
13,600 G	19,100 G	1,000 M	15,298813 G	-26.57	-13.57																																																																										
Highest Channel	Highest Channel																																																																														
 <table border="1" data-bbox="239 1601 638 1691"> <thead> <tr> <th>Start [Hz]</th> <th>Stop [Hz]</th> <th>RBW [Hz]</th> <th>Freq [Hz]</th> <th>PwrAbs [dBm]</th> <th>ΔLimit [dB]</th> </tr> </thead> <tbody> <tr><td>30,000 M</td><td>820,000 M</td><td>1,000 M</td><td>819,830000 M</td><td>-38.95</td><td>-25.95</td></tr> <tr><td>855,000 M</td><td>1,000 G</td><td>1,000 M</td><td>893,860000 M</td><td>-42.60</td><td>-29.60</td></tr> <tr><td>1,000 G</td><td>3,000 G</td><td>1,000 M</td><td>1,696000 G</td><td>-40.55</td><td>-27.55</td></tr> <tr><td>3,000 G</td><td>7,000 G</td><td>1,000 M</td><td>3,737000 G</td><td>-38.72</td><td>-25.72</td></tr> <tr><td>7,000 G</td><td>9,000 G</td><td>1,000 M</td><td>8,393500 G</td><td>-36.20</td><td>-23.20</td></tr> </tbody> </table> <p>Date: 6.JUN.2018 17:58:11</p>	Start [Hz]	Stop [Hz]	RBW [Hz]	Freq [Hz]	PwrAbs [dBm]	ΔLimit [dB]	30,000 M	820,000 M	1,000 M	819,830000 M	-38.95	-25.95	855,000 M	1,000 G	1,000 M	893,860000 M	-42.60	-29.60	1,000 G	3,000 G	1,000 M	1,696000 G	-40.55	-27.55	3,000 G	7,000 G	1,000 M	3,737000 G	-38.72	-25.72	7,000 G	9,000 G	1,000 M	8,393500 G	-36.20	-23.20	 <table border="1" data-bbox="877 1601 1276 1691"> <thead> <tr> <th>Start [Hz]</th> <th>Stop [Hz]</th> <th>RBW [Hz]</th> <th>Freq [Hz]</th> <th>PwrAbs [dBm]</th> <th>ΔLimit [dB]</th> </tr> </thead> <tbody> <tr><td>30,000 M</td><td>1,000 G</td><td>1,000 M</td><td>170,407500 M</td><td>-37.55</td><td>-24.55</td></tr> <tr><td>1,000 G</td><td>1,845 G</td><td>1,000 M</td><td>1,039293 G</td><td>-42.06</td><td>-29.06</td></tr> <tr><td>1,845 G</td><td>3,000 G</td><td>1,000 M</td><td>1,932791 G</td><td>-40.83</td><td>-27.83</td></tr> <tr><td>3,000 G</td><td>7,000 G</td><td>1,000 M</td><td>5,727000 G</td><td>-37.01</td><td>-24.01</td></tr> <tr><td>7,000 G</td><td>13,600 G</td><td>1,000 M</td><td>10,208425 G</td><td>-35.62</td><td>-22.62</td></tr> <tr><td>13,600 G</td><td>19,100 G</td><td>1,000 M</td><td>15,305438 G</td><td>-26.76</td><td>-13.76</td></tr> </tbody> </table> <p>Date: 6.JUN.2018 18:15:55</p>	Start [Hz]	Stop [Hz]	RBW [Hz]	Freq [Hz]	PwrAbs [dBm]	ΔLimit [dB]	30,000 M	1,000 G	1,000 M	170,407500 M	-37.55	-24.55	1,000 G	1,845 G	1,000 M	1,039293 G	-42.06	-29.06	1,845 G	3,000 G	1,000 M	1,932791 G	-40.83	-27.83	3,000 G	7,000 G	1,000 M	5,727000 G	-37.01	-24.01	7,000 G	13,600 G	1,000 M	10,208425 G	-35.62	-22.62	13,600 G	19,100 G	1,000 M	15,305438 G	-26.76	-13.76
Start [Hz]	Stop [Hz]	RBW [Hz]	Freq [Hz]	PwrAbs [dBm]	ΔLimit [dB]																																																																										
30,000 M	820,000 M	1,000 M	819,830000 M	-38.95	-25.95																																																																										
855,000 M	1,000 G	1,000 M	893,860000 M	-42.60	-29.60																																																																										
1,000 G	3,000 G	1,000 M	1,696000 G	-40.55	-27.55																																																																										
3,000 G	7,000 G	1,000 M	3,737000 G	-38.72	-25.72																																																																										
7,000 G	9,000 G	1,000 M	8,393500 G	-36.20	-23.20																																																																										
Start [Hz]	Stop [Hz]	RBW [Hz]	Freq [Hz]	PwrAbs [dBm]	ΔLimit [dB]																																																																										
30,000 M	1,000 G	1,000 M	170,407500 M	-37.55	-24.55																																																																										
1,000 G	1,845 G	1,000 M	1,039293 G	-42.06	-29.06																																																																										
1,845 G	3,000 G	1,000 M	1,932791 G	-40.83	-27.83																																																																										
3,000 G	7,000 G	1,000 M	5,727000 G	-37.01	-24.01																																																																										
7,000 G	13,600 G	1,000 M	10,208425 G	-35.62	-22.62																																																																										
13,600 G	19,100 G	1,000 M	15,305438 G	-26.76	-13.76																																																																										



Frequency Stability

Test Conditions	Middle Channel	CDMA BC0 (1xEV-DO Rev. 0)	Limit 2.5ppm
Temperature (°C)	Voltage (Volt)	Deviation (ppm)	Result
50	Normal Voltage	0.0012	PASS
40	Normal Voltage	0.0012	
30	Normal Voltage	0.0012	
20(Ref.)	Normal Voltage	0.0000	
10	Normal Voltage	0.0012	
0	Normal Voltage	0.0012	
-10	Normal Voltage	0.0012	
-20	Normal Voltage	0.0000	
-30	Normal Voltage	0.0012	
20	Maximum Voltage	0.0012	
20	Normal Voltage	0.0000	
20	Battery End Point	0.0012	

Test Conditions	Middle Channel	CDMA BC1 (1xEV-DO Rev. 0)	Limit Note 2.
Temperature (°C)	Voltage (Volt)	Deviation (ppm)	Result
50	Normal Voltage	0.0021	PASS
40	Normal Voltage	0.0005	
30	Normal Voltage	0.0000	
20(Ref.)	Normal Voltage	0.0000	
10	Normal Voltage	0.0000	
0	Normal Voltage	0.0005	
-10	Normal Voltage	0.0005	
-20	Normal Voltage	0.0005	
-30	Normal Voltage	0.0016	
20	Maximum Voltage	0.0005	
20	Normal Voltage	0.0000	
20	Battery End Point	0.0005	

Note:

1. Normal Voltage = 12 V. ; Battery End Point (BEP) = 8 V. ; Maximum Voltage = 40 V
2. The frequency fundamental emissions stay within the authorized frequency block based on the frequency deviation measured is small.



Appendix B. Test Results of ERP/EIRP and Radiated Test

ERP/EIRP

Channel	Mode	Conducted		ERP	
		Power (dBm)	Power (Watts)	ERP(dBm)	ERP(W)
Lowest	CDMA BC0 1xRTT (GT - LC = 5.65 dB)	23.55	0.2265	27.05	0.5070
Middle		23.60	0.2291	27.10	0.5129
Highest		23.52	0.2249	27.02	0.5035
Lowest	CDMA BC0 1xEV-DO (GT - LC = 5.65 dB)	23.56	0.2270	27.06	0.5082
Middle		23.61	0.2296	27.11	0.5140
Highest		23.58	0.2280	27.08	0.5105
Limit	ERP < 7W	Result		PASS	

Channel	Mode	Conducted		EIRP	
		Power (dBm)	Power (Watts)	EIRP(dBm)	EIRP(W)
Lowest	CDMA BC1 1xRTT (GT - LC = 4.17 dB)	23.82	0.2410	27.99	0.6295
Middle		23.76	0.2377	27.93	0.6209
Highest		23.85	0.2427	28.02	0.6339
Lowest	CDMA BC1 1xEV-DO (GT - LC = 4.17 dB)	23.85	0.2427	28.02	0.6339
Middle		23.77	0.2382	27.94	0.6223
Highest		23.86	0.2432	28.03	0.6353
Limit	EIRP < 2W	Result		PASS	



Radiated Spurious Emission

Part22H CDMA BC0 1xEVDO

CDMA BC0 1xEVDO									
Channel	Frequency (MHz)	ERP (dBm)	Limit (dBm)	Over Limit (dB)	SPA Reading (dBm)	S.G. Power (dBm)	TX Cable loss (dB)	TX Antenna Gain (dBi)	Polarization (H/V)
Lowest	1648	-61.74	-13	-48.74	-72.97	-67.33	0.92	8.66	H
	2472	-57.52	-13	-44.52	-73.54	-64.89	1.14	10.66	H
	3299	-56.99	-13	-43.99	-74.72	-65.53	1.32	12.02	H
									H
									H
									H
									H
	1648	-57.97	-13	-44.97	-68.66	-63.56	0.92	8.66	V
	2472	-54.20	-13	-41.20	-70.4	-61.57	1.14	10.66	V
	3299	-56.38	-13	-43.38	-74.57	-64.92	1.32	12.02	V
									V
									V
									V
									V



Middle	1672	-60.16	-13	-47.16	-71.47	-65.84	0.93	8.75	H
	2512	-57.35	-13	-44.35	-73.39	-64.76	1.15	10.71	H
	3346	-56.71	-13	-43.71	-74.32	-65.36	1.33	12.13	H
									H
									H
									H
									H
	1672	-52.44	-13	-39.44	-63.09	-58.12	0.93	8.75	V
	2512	-53.38	-13	-40.38	-69.6	-60.79	1.15	10.71	V
	3346	-56.37	-13	-43.37	-74.43	-65.02	1.33	12.13	V
									V
									V
									V
									V
Highest	1696	-61.17	-13	-48.17	-72.54	-66.93	0.94	8.84	H
	2544	-54.12	-13	-41.12	-70.16	-61.56	1.16	10.75	H
	3393	-56.41	-13	-43.41	-73.88	-65.16	1.34	12.24	H
									H
									H
									H
									H
	1696	-52.89	-13	-39.89	-63.52	-58.65	0.94	8.84	V
	2544	-46.25	-13	-33.25	-62.38	-53.69	1.16	10.75	V
	3393	-56.11	-13	-43.11	-74.01	-64.86	1.34	12.24	V
									V
									V
									V
									V
								V	

Remark: Spurious emissions within 30-1000MHz were found more than 20dB below limit line.



Part24E CDMA BC1 1xEVDO

CDMA BC1 1xEVDO									
Channel	Frequency (MHz)	EIRP (dBm)	Limit (dBm)	Over Limit (dB)	SPA Reading (dBm)	S.G. Power (dBm)	TX Cable loss (dB)	TX Antenna Gain (dBi)	Polarization (H/V)
Lowest	3700	-43.85	-13	-30.85	-64.04	-55.06	1.41	12.62	H
	5555	-40.68	-13	-27.68	-65.93	-52.24	1.74	13.30	H
	7405	-45.91	-13	-32.91	-74.25	-55.22	1.94	11.25	H
									H
									H
									H
									H
	3700	-45.26	-13	-32.26	-65.59	-56.47	1.41	12.62	V
	5555	-41.39	-13	-28.39	-66.16	-52.95	1.74	13.30	V
	7405	-46.20	-13	-33.20	-74.4	-55.51	1.94	11.25	V
									V
									V
									V
									V
Middle	3763	-49.60	-13	-36.60	-70.05	-60.83	1.43	12.66	H
	5639	-43.19	-13	-30.19	-68.45	-54.76	1.73	13.30	H
	7520	-46.53	-13	-33.53	-74.36	-55.64	1.99	11.10	H
									H
									H
									H
									H
	3763	-49.21	-13	-36.21	-69.88	-60.44	1.43	12.66	V
	5639	-43.29	-13	-30.29	-68.15	-54.86	1.73	13.30	V
	7520	-46.56	-13	-33.56	-74.35	-55.67	1.99	11.10	V
									V
									V
									V
									V



Highest	3819	-48.15	-13	-35.15	-68.79	-59.40	1.44	12.69	H
	5723	-41.63	-13	-28.63	-67.29	-53.20	1.73	13.30	H
	7635	-46.67	-13	-33.67	-74.17	-55.79	2.01	11.13	H
									H
									H
									H
									H
	3819	-49.01	-13	-36.01	-69.89	-60.26	1.44	12.69	V
	5723	-41.63	-13	-28.63	-66.65	-53.20	1.73	13.30	V
	7635	-46.73	-13	-33.73	-74.14	-55.85	2.01	11.13	V
									V
									V
									V
									V

Remark: Spurious emissions within 30-1000MHz were found more than 20dB below limit line.