



FCC RADIO TEST REPORT

FCC ID : XIA-IFWA40
Equipment : Wireless Home Internet
Brand Name : Netcomm
Model Name : IFWA-40
Applicant : NetComm Wireless Limited
18-20 Orion Road Lane Cove NSW 2066 Australia
Manufacturer : NetComm Wireless Limited
18-20 Orion Road Lane Cove NSW 2066 Australia
Standard : 47 CFR FCC Part 15.407

The product was received on Oct. 22, 2018, and testing was started from Dec. 24, 2018 and completed on Mar. 18, 2019. We, SPORTON INTERNATIONAL INC. EMC & Wireless Communications Laboratory, would like to declare that the tested sample has been evaluated in accordance with the procedures given in ANSI C63.10-2013 and shown compliance with the applicable technical standards.

The report must not be used by the client to claim product certification, approval, or endorsement by TAF or any agency of government.

The test results in this report apply exclusively to the tested model / sample. Without written approval of SPORTON INTERNATIONAL INC. EMC & Wireless Communications Laboratory, the test report shall not be reproduced except in full.

Approved by: Sam Chen

SPORTON INTERNATIONAL INC. EMC & Wireless Communications Laboratory
No. 52, Huaya 1st Rd., Guishan Dist., Taoyuan City, Taiwan (R.O.C.)



Table of Contents

History of this test report.....3

Summary of Test Result.....4

1 General Description5

1.1 Information.....5

1.2 Testing Applied Standards7

1.3 Testing Location Information.....7

1.4 Measurement Uncertainty7

2 Test Configuration of EUT8

2.1 Test Channel Mode8

2.2 The Worst Case Measurement Configuration.....9

2.3 EUT Operation during Test10

2.4 Accessories10

2.5 Support Equipment.....10

2.6 Test Setup Diagram12

3 Transmitter Test Result15

3.1 AC Power-line Conducted Emissions15

3.2 Emission Bandwidth.....17

3.3 Maximum Conducted Output Power18

3.4 Peak Power Spectral Density.....20

3.5 Unwanted Emissions.....23

4 Test Equipment and Calibration Data27

Appendix A. Test Results of AC Power-line Conducted Emissions

Appendix B. Test Results of Emission Bandwidth

Appendix C. Test Results of Maximum Conducted Output Power

Appendix D. Test Results of Peak Power Spectral Density

Appendix E. Test Results of Unwanted Emissions

Appendix F. Test Photos

Photographs of EUT v01



History of this test report

Report No.	Version	Description	Issued Date
FR801751AB	01	Initial issue of report	Apr. 02, 2019



Summary of Test Result

Report Clause	Ref Std. Clause	Test Items	Result (PASS/FAIL)	Remark
1.1.2	15.203	Antenna Requirement	PASS	-
3.1	15.207	AC Power-line Conducted Emissions	PASS	-
3.2	15.407(a)	Emission Bandwidth	PASS	-
3.3	15.407(a)	Maximum Conducted Output Power	PASS	-
3.4	15.407(a)	Peak Power Spectral Density	PASS	-
3.5	15.407(b)	Unwanted Emissions	PASS	-

Declaration of Conformity:

The test results with all measurement uncertainty excluded are presented in accordance with the regulation limits or requirements declared by manufacturers.

Comments and Explanations:

- 1.The test configuration, test mode and test software were written in this test report are declared by the manufacturer.
- 2.The declared of product specification for EUT presented in the report are provided by the manufacturer, and the manufacturer takes all the responsibilities for the accuracy of product specification.

Reviewed by: **Sam Chen**

Report Producer: **Viola Huang**



1 General Description

1.1 Information

1.1.1 RF General Information

Frequency Range (MHz)	IEEE Std. 802.11	Ch. Frequency (MHz)	Channel Number
5150-5250	a, n (HT20), ac (VHT20)	5180-5240	36-48 [4]
5725-5850		5745-5825	149-165 [5]
5150-5250	n (HT40), ac (VHT40)	5190-5230	38-46 [2]
5725-5850		5755-5795	151-159 [2]
5150-5250	ac (VHT80)	5210	42 [1]
5725-5850		5775	155 [1]

Band	Mode	BWch (MHz)	Nant
5.15-5.25GHz	802.11a	20	2TX
5.15-5.25GHz	802.11n HT20	20	2TX
5.15-5.25GHz	802.11ac VHT20	20	2TX
5.15-5.25GHz	802.11n HT40	40	2TX
5.15-5.25GHz	802.11ac VHT40	40	2TX
5.15-5.25GHz	802.11ac VHT80	80	2TX
5.725-5.85GHz	802.11a	20	2TX
5.725-5.85GHz	802.11n HT20	20	2TX
5.725-5.85GHz	802.11ac VHT20	20	2TX
5.725-5.85GHz	802.11n HT40	40	2TX
5.725-5.85GHz	802.11ac VHT40	40	2TX
5.725-5.85GHz	802.11ac VHT80	80	2TX

Note:

- ♦ 11a, HT20 and HT40 use a combination of OFDM-BPSK, QPSK, 16QAM, 64QAM modulation.
- ♦ VHT20, VHT40, VHT80 use a combination of OFDM-BPSK, QPSK, 16QAM, 64QAM, 256QAM modulation.
- ♦ BWch is the nominal channel bandwidth.
- ♦ Nss-Min is the minimum number of spatial streams.
- ♦ Nant is the number of outputs. e.g., 2(2,3) means have 2 outputs for port 2 and port 3. 2 means have 2 outputs for port 1 and port 2.



1.1.2 Antenna Information

Ant.	Port	Brand	Model Name	Antenna Type	Connector	Gain (dBi)		
						2.4G	5G Band 1	5G Band 4
1	1	Netcomm	-	Printed PIFA Antenna	N/A	5.17	-	-
2	2	Netcomm	-	Printed PIFA Antenna	N/A	3.9	-	-
3	1	Netcomm	-	Printed PIFA Antenna	N/A	-	5	4.45
4	2	Netcomm	-	Printed PIFA Antenna	N/A	-	5.79	5.1

Note: The above information was declared by manufacturer.

Note: The EUT has four WLAN antennas.

For WLAN 2.4GHz (2TX/2RX):

Ant. 1 (Port 1) and Ant. 2 (Port 2) could transmit/receive simultaneously.

For WLAN 5GHz (2TX/2RX):

Ant. 3 (Port 1) and Ant. 4 (Port 2) could transmit/receive simultaneously.

1.1.3 Mode Test Duty Cycle

Mode	DC	DCF(dB)	T(s)	VBW(Hz) ≥ 1/T
802.11a	0.968	0.141	2.065m	1k
802.11ac VHT20	0.872	0.595	5.015m	300
802.11ac VHT40	0.775	1.107	2.437m	1k
802.11ac VHT80	0.839	0.762	3.355m	300

Note:

- ◆ DC is Duty Cycle.
- ◆ DCF is Duty Cycle Factor.

1.1.4 EUT Operational Condition

EUT Power Type	From Power Adapter or Lithium-ion Battery Pack (For backup purposes only during a power outage)			
Beamforming Function	<input type="checkbox"/> With beamforming	<input checked="" type="checkbox"/> Without beamforming		
Function	<input type="checkbox"/> Outdoor P2M	<input checked="" type="checkbox"/> Indoor P2M		
	<input type="checkbox"/> Fixed P2P	<input type="checkbox"/> Client		
Test Software Version	QRCT-4.0.00088			

Note: The above information was declared by manufacturer.



1.2 Testing Applied Standards

According to the specifications of the manufacturer, the EUT must comply with the requirements of the following standards:

- ♦ 47 CFR FCC Part 15
- ♦ ANSI C63.10-2013
- ♦ FCC KDB 789033 D02 v02r01
- ♦ FCC KDB 662911 D01 v02r01
- ♦ FCC KDB 412172 D01 v01r01

1.3 Testing Location Information

Testing Location		
<input type="checkbox"/>	HWA YA	ADD : No. 52, Huaya 1st Rd., Guishan Dist., Taoyuan City, Taiwan (R.O.C.) TEL : 886-3-327-3456 FAX : 886-3-327-0973
<input checked="" type="checkbox"/>	JHUBEI	ADD : No.8, Lane 724, Bo-ai St., Jhubei City, HsinChu County 302, Taiwan, R.O.C. TEL : 886-3-656-9065 FAX : 886-3-656-9085

Test Condition	Test Site No.	Test Engineer	Test Environment	Test Date
RF Conducted	TH01-CB	Welson Chen	21°C~23°C / 53%~55%	Feb. 14, 2019 ~ Feb. 26, 2019
Radiated (For below 1GHz)	03CH01-CB	Eason Chen	21°C~23°C / 53%~55%	Feb. 16, 2019 ~ Mar. 18, 2019
Radiated (For above 1GHz)	03CH01-CB	Eason Chen	21°C~23°C / 53%~55%	Jan. 26, 2019 ~ Feb. 26, 2019
AC Conduction	CO02-CB	Max Lin	23°C / 55%	Dec. 24, 2018

Test site Designation No. TW0006 with FCC
Test site registered number IC 4086B with Industry Canada.

1.4 Measurement Uncertainty

ISO/IEC 17025 requires that an estimate of the measurement uncertainties associated with the emissions test results be included in the report. The measurement uncertainties given below are based on a 95% confidence level (based on a coverage factor (k=2))

Test Items	Uncertainty	Remark
Conducted Emission (150kHz ~ 30MHz)	2.0 dB	Confidence levels of 95%
Radiated Emission (30MHz ~ 1,000MHz)	3.6 dB	Confidence levels of 95%
Radiated Emission (1GHz ~ 18GHz)	3.7 dB	Confidence levels of 95%
Radiated Emission (18GHz ~ 40GHz)	3.5 dB	Confidence levels of 95%
Conducted Emission	1.7 dB	Confidence levels of 95%
Output Power Measurement	1.33 dB	Confidence levels of 95%
Power Density Measurement	1.27 dB	Confidence levels of 95%
Bandwidth Measurement	9.74 x10 ⁻⁸	Confidence levels of 95%



2 Test Configuration of EUT

2.1 Test Channel Mode

Mode	PowerSetting
802.11a_Nss1,(6Mbps)_2TX	-
5180MHz	16.5
5200MHz	17
5240MHz	17
5745MHz	16
5785MHz	16
5825MHz	16
802.11ac VHT20_Nss1,(MCS0)_2TX	-
5180MHz	16.5
5200MHz	17
5240MHz	17
5745MHz	16
5785MHz	16
5825MHz	16
802.11ac VHT40_Nss1,(MCS0)_2TX	-
5190MHz	14
5230MHz	17
5755MHz	16
5795MHz	16
802.11ac VHT80_Nss1,(MCS0)_2TX	-
5210MHz	13.5
5775MHz	16.5

Note:

- ♦ VHT20/VHT40 covers HT20/HT40, due to same modulation. The power setting for 802.11n HT20 and HT40 are the same or lower than 802.11ac VHT20 and VHT40.



2.2 The Worst Case Measurement Configuration

The Worst Case Mode for Following Conformance Tests	
Tests Item	AC power-line conducted emissions
Condition	AC power-line conducted measurement for line and neutral
Operating Mode	Normal Link
1	EUT + WCDMA Band 2 + WLAN + Adapter
2	EUT + LTE Band 5 + WLAN + Adapter
For operating mode 2 is the worst case and it was record in this test report.	

The Worst Case Mode for Following Conformance Tests	
Tests Item	Emission Bandwidth Maximum Conducted Output Power Peak Power Spectral Density
Test Condition	Conducted measurement at transmit chains

The Worst Case Mode for Following Conformance Tests	
Tests Item	Unwanted Emissions
Test Condition	Radiated measurement If EUT consist of multiple antenna assembly (multiple antenna are used in EUT regardless of spatial multiplexing MIMO configuration), the radiated test should be performed with highest antenna gain of each antenna type.
Operating Mode < 1GHz	Normal Link
1	EUT in Z axis + LTE Band 5 + WLAN + Adapter
2	EUT in Y axis + LTE Band 5 + WLAN + Adapter
Mode 1 has been evaluated to be the worst case between Mode 1~2, thus measurement for Mode 3 will follow this same test mode.	
3	EUT in Z axis + WCDMA Band 2 + WLAN + Adapter
Mode 3 has been evaluated to be the worst case between Mode 1~3, thus measurement for Mode 4 will follow this same test mode.	
4	EUT in Z axis + WCDMA Band 2 + WLAN + Battery
For operating mode 3 is the worst case and it was record in this test report.	
Operating Mode > 1GHz	CTX The EUT was performed at Y axis and Z axis position for Radiated emission above 1GHz test, and the worst case was found at Z axis. So the measurement will follow this same test configuration.
1	EUT in Z axis

Note: The USB function was not evaluated by manufacturer request.



2.3 EUT Operation during Test

For CTX Mode:

The EUT was programmed to be in continuously transmitting mode.

For Normal Link:

During the test, the EUT operation to normal function.

2.4 Accessories

Accessories				
No.	Equipment Name	Brand Name	Model Name	Rating
1	Adapter	DVE/CUI	DSA-18PFR-12 FUS 090200	Input: 100-240V~50/60Hz, 0.6A Output: +9V, 2A
2	Lithium-ion Battery	NetComm	BAT-40	3.7VDC, 3000mAh, 11.1Wh

2.5 Support Equipment

For Test Site No: CO02-CB

Support Equipment				
No.	Equipment	Brand Name	Model Name	FCC ID
A	NB	DELL	E6430	N/A
B	NB	DELL	E6430	N/A
C	NB	DELL	E6430	N/A
D	LTE Base station	Anritsu	MT8820C	N/A
E	Phone	SAMPO	HT-B 907WL	N/A
F	Phone	SAMPO	HT-B 907WL	N/A
G	SIM card	N/A	N/A	N/A



For Test Site No: 03CH01-CB (below 1GHz)

Support Equipment				
No.	Equipment	Brand Name	Model Name	FCC ID
A	NB	DELL	E4300	N/A
B	NB	DELL	E4300	N/A
C	NB	DELL	E4300	N/A
D	LTE base station	Anritsu	MT8820C	N/A
E	Phone	H-T-T	F-689	N/A
F	Phone	H-T-T	F-689	N/A
G	SIM card	N/A	N/A	N/A

For Test Site No: 03CH01-CB (above 1GHz) and TH01-CB

Support Equipment				
No.	Equipment	Brand Name	Model Name	FCC ID
A	NB	Lenovo	TP00048A	N/A

2.6 Test Setup Diagram

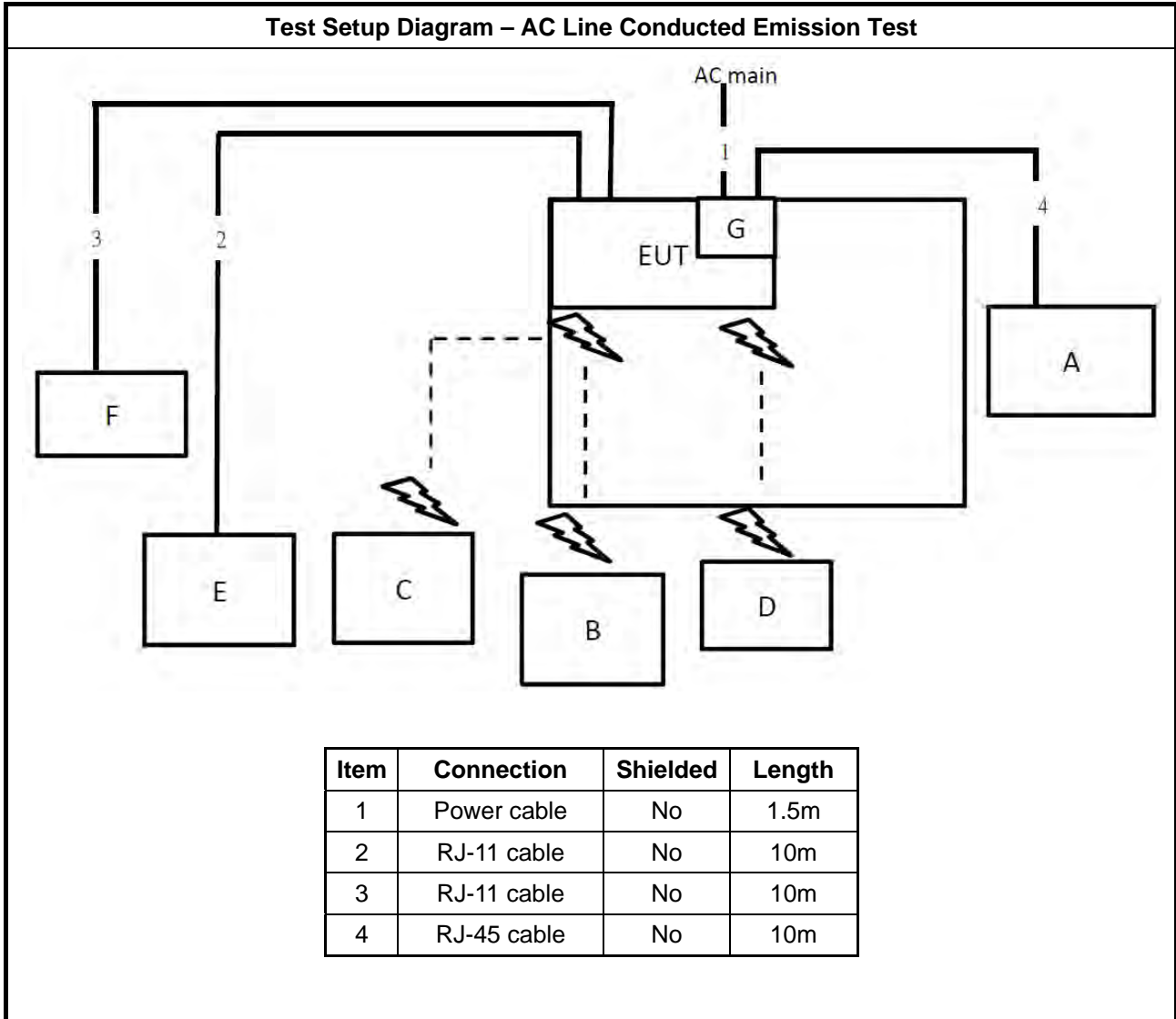

Test Setup Diagram - Radiated Test < 1GHz

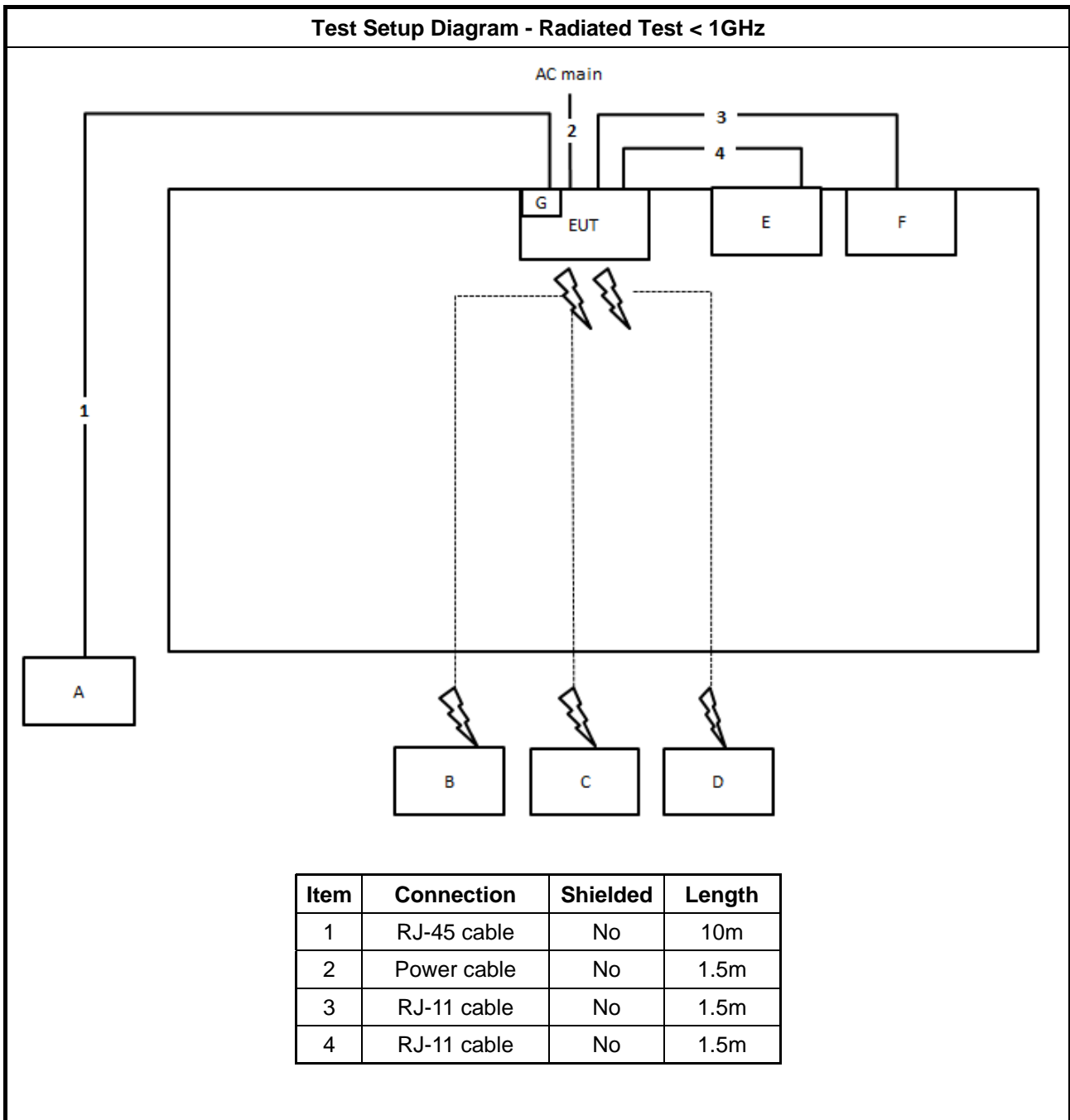

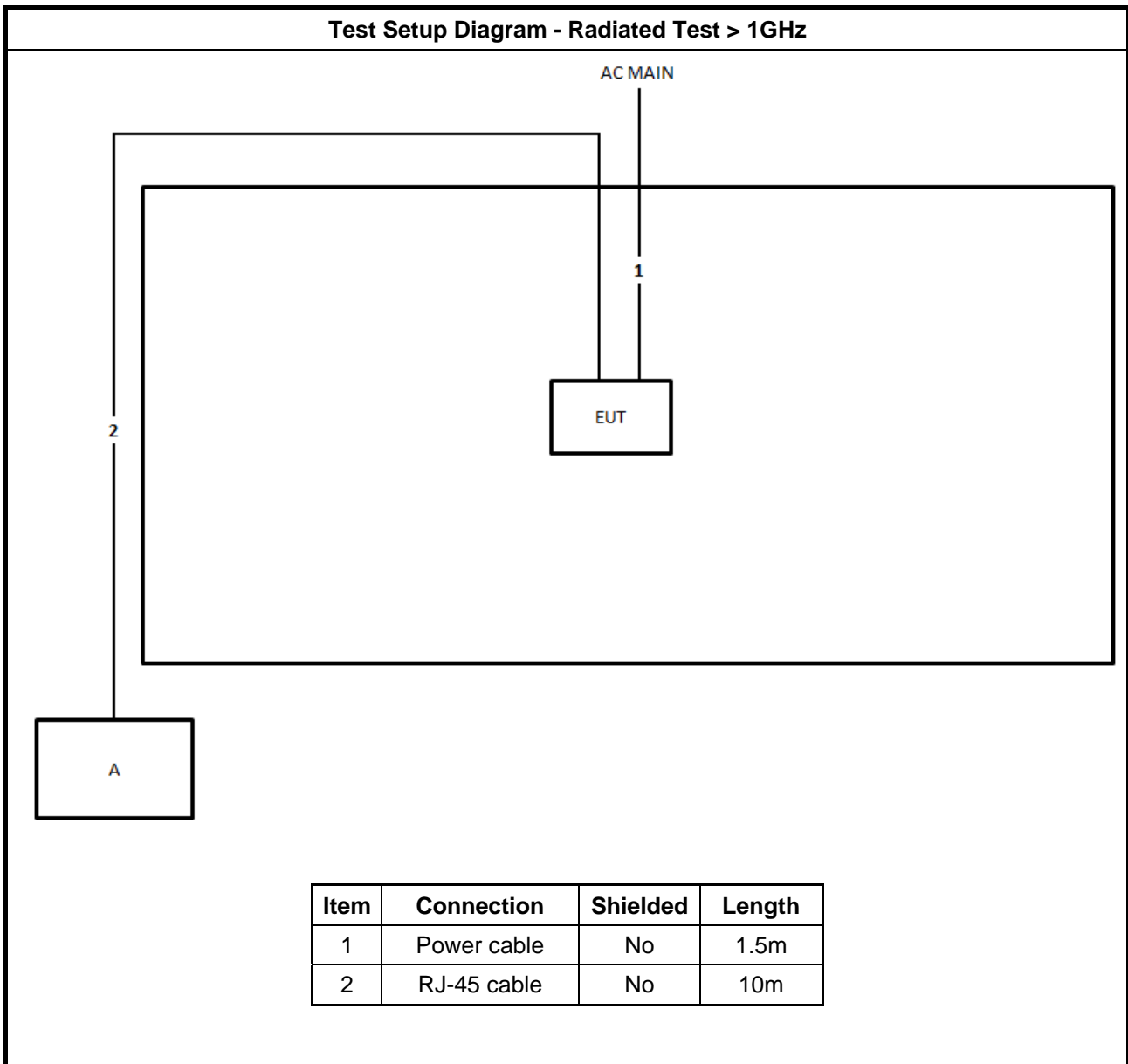



3 Transmitter Test Result

3.1 AC Power-line Conducted Emissions

3.1.1 AC Power-line Conducted Emissions Limit

AC Power-line Conducted Emissions Limit		
Frequency Emission (MHz)	Quasi-Peak	Average
0.15-0.5	66 - 56 *	56 - 46 *
0.5-5	56	46
5-30	60	50

Note 1: * Decreases with the logarithm of the frequency.

3.1.2 Measuring Instruments

Refer a test equipment and calibration data table in this test report.

3.1.3 Test Procedures

Test Method
<input checked="" type="checkbox"/> Refer as ANSI C63.10-2013, clause 6.2 for AC power-line conducted emissions.

3.1.4 Test Setup

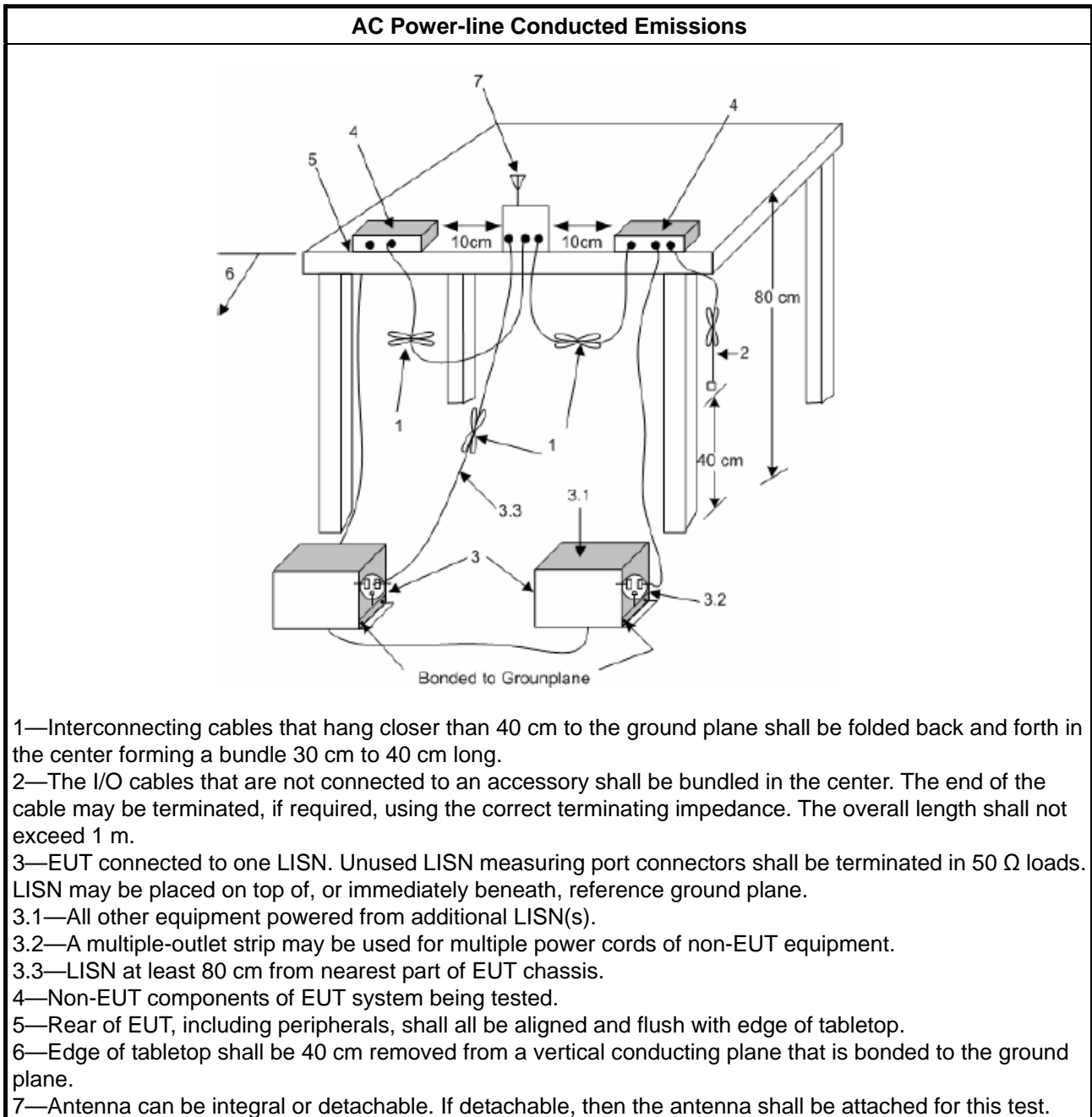

3.1.5 Test Result of AC Power-line Conducted Emissions

Refer as Appendix A

3.2 Emission Bandwidth

3.2.1 Emission Bandwidth Limit

Emission Bandwidth Limit	
UNII Devices	
<input checked="" type="checkbox"/>	For the 5.15-5.25 GHz band, N/A
<input type="checkbox"/>	For the 5.25-5.35 GHz band, the maximum conducted output power shall not exceed the lesser of 250 mW or 11 dBm + 10 log B, where B is the 26 dB emission bandwidth in MHz.
<input type="checkbox"/>	For the 5.47-5.725 GHz band, the maximum conducted output power shall not exceed the lesser of 250 mW or 11 dBm + 10 log B, where B is the 26 dB emission bandwidth in MHz.
<input checked="" type="checkbox"/>	For the 5.725-5.85 GHz band, 6 dB emission bandwidth \geq 500kHz.
LE-LAN Devices	
<input type="checkbox"/>	For the band 5.15-5.25 GHz, the maximum e.i.r.p. shall not exceed 200 mW or 10 + 10 log B, dBm, whichever power is less. B is the 99% emission bandwidth in MHz.
<input type="checkbox"/>	For the 5.25-5.35 GHz band, the maximum e.i.r.p. shall not exceed 1.0 W or 17 + 10 log B, dBm, whichever power is less. B is the 99% emission bandwidth in MHz
<input type="checkbox"/>	For the 5.47-5.6 GHz band and 5.65-5.725 GHz band, the maximum e.i.r.p. shall not exceed 1.0 W or 17 + 10 log B, dBm, whichever power is less. B is the 99% emission bandwidth in MHz
<input type="checkbox"/>	For the 5.725-5.85 GHz band, 6 dB emission bandwidth \geq 500kHz.

3.2.2 Measuring Instruments

Refer a test equipment and calibration data table in this test report.

3.2.3 Test Procedures

Test Method							
<ul style="list-style-type: none"> ▪ For the emission bandwidth shall be measured using one of the options below: <table border="1" style="width: 100%; border-collapse: collapse;"> <tr> <td style="width: 30px;"><input checked="" type="checkbox"/></td> <td>Refer as FCC KDB 789033, clause C for EBW and clause D for OBW measurement.</td> </tr> <tr> <td><input type="checkbox"/></td> <td>Refer as ANSI C63.10, clause 6.9.1 for occupied bandwidth testing.</td> </tr> <tr> <td><input type="checkbox"/></td> <td>Refer as IC RSS-Gen, clause 4.6 for bandwidth testing.</td> </tr> </table> 		<input checked="" type="checkbox"/>	Refer as FCC KDB 789033, clause C for EBW and clause D for OBW measurement.	<input type="checkbox"/>	Refer as ANSI C63.10, clause 6.9.1 for occupied bandwidth testing.	<input type="checkbox"/>	Refer as IC RSS-Gen, clause 4.6 for bandwidth testing.
<input checked="" type="checkbox"/>	Refer as FCC KDB 789033, clause C for EBW and clause D for OBW measurement.						
<input type="checkbox"/>	Refer as ANSI C63.10, clause 6.9.1 for occupied bandwidth testing.						
<input type="checkbox"/>	Refer as IC RSS-Gen, clause 4.6 for bandwidth testing.						

3.2.4 Test Setup

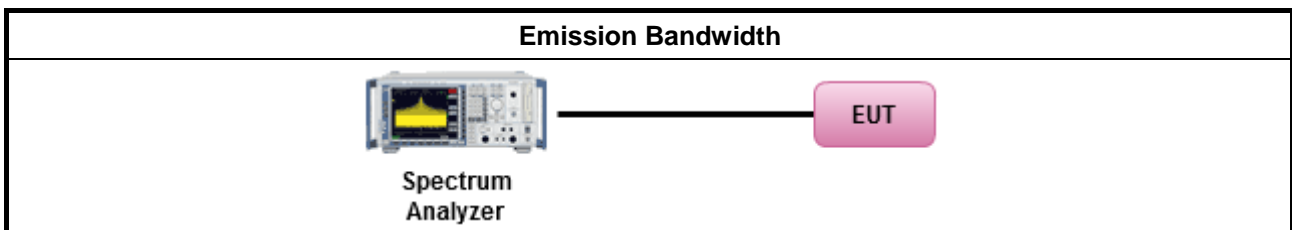

3.2.5 Test Result of Emission Bandwidth

Refer as Appendix B



3.3 Maximum Conducted Output Power

3.3.1 Maximum Conducted Output Power Limit

Maximum Conducted Output Power Limit	
UNII Devices	
<input checked="" type="checkbox"/> For the 5.15-5.25 GHz band:	
	<ul style="list-style-type: none"> ▪ Outdoor AP: the maximum conducted output power (P_{Out}) shall not exceed the lesser of 1 W. If $G_{TX} > 6$ dBi, then $P_{Out} = 30 - (G_{TX} - 6)$. e.i.r.p. at any elevation angle above 30 degrees $\leq 125mW$ [21dBm] ▪ Indoor AP: the maximum conducted output power (P_{Out}) shall not exceed the lesser of 1 W. If $G_{TX} > 6$ dBi, then $P_{Out} = 30 - (G_{TX} - 6)$ ▪ Point-to-point AP: the maximum conducted output power (P_{Out}) shall not exceed the lesser of 1 W. If $G_{TX} > 23$ dBi, then $P_{Out} = 30 - (G_{TX} - 23)$. ▪ Mobile or Portable Client: the maximum conducted output power (P_{Out}) shall not exceed the lesser of 250 mW. If $G_{TX} > 6$ dBi, then $P_{Out} = 24 - (G_{TX} - 6)$.
<input type="checkbox"/> For the 5.25-5.35 GHz band, the maximum conducted output power (P_{Out}) shall not exceed the lesser of 250 mW or 11 dBm + 10 log B, where B is the 26 dB emission bandwidth in MHz. If $G_{TX} > 6$ dBi, then $P_{Out} = 24 - (G_{TX} - 6)$.	
<input type="checkbox"/> For the 5.47-5.725 GHz band, the maximum conducted output power (P_{Out}) shall not exceed the lesser of 250 mW or 11 dBm + 10 log B, where B is the 26 dB emission bandwidth in MHz. If $G_{TX} > 6$ dBi, then $P_{Out} = 24 - (G_{TX} - 6)$.	
<input checked="" type="checkbox"/> For the 5.725-5.85 GHz band:	
	<ul style="list-style-type: none"> ▪ Point-to-multipoint systems (P2M): the maximum conducted output power (P_{Out}) shall not exceed the lesser of 1 W. If $G_{TX} > 6$ dBi, then $P_{Out} = 30 - (G_{TX} - 6)$. ▪ Point-to-point systems (P2P): the maximum conducted output power (P_{Out}) shall not exceed the lesser of 1 W.
LE-LAN Devices	
<input type="checkbox"/> For the 5.15-5.25 GHz band, the maximum e.i.r.p. shall not exceed 200 mW or 10 + 10 log B, dBm, whichever power is less. B is the 99% emission bandwidth in MHz.	
<input type="checkbox"/> For the 5.25-5.35 GHz band, the maximum e.i.r.p. shall not exceed 1.0 W or 17 + 10 log B, dBm, whichever power is less. B is the 99% emission bandwidth in MHz	
<input type="checkbox"/> For the 5.47-5.6 GHz band and 5.65-5.725 GHz band, the maximum e.i.r.p. shall not exceed 1.0 W or 17 + 10 log B, dBm, whichever power is less. B is the 99% emission bandwidth in MHz	
<input type="checkbox"/> For the 5.725-5.85 GHz band:	
	<ul style="list-style-type: none"> ▪ Point-to-multipoint systems (P2M): the maximum conducted output power (P_{Out}) shall not exceed the lesser of 1 W. If $G_{TX} > 6$ dBi, then $P_{Out} = 30 - (G_{TX} - 6)$. ▪ Point-to-point systems (P2P): the maximum conducted output power (P_{Out}) shall not exceed the lesser of 1 W.
P_{Out} = maximum conducted output power in dBm, G_{TX} = the maximum transmitting antenna directional gain in dBi.	

3.3.2 Measuring Instruments

Refer a test equipment and calibration data table in this test report.

3.3.3 Test Procedures

Test Method	
<ul style="list-style-type: none"> ▪ Maximum Conducted Output Power 	
Average over on/off periods with duty factor	
<input type="checkbox"/> Refer as FCC KDB 789033, clause E Method SA-2 (spectral trace averaging).	
<input type="checkbox"/> Refer as FCC KDB 789033, clause E Method SA-2 Alt. (RMS detection with slow sweep speed)	
Wideband RF power meter and average over on/off periods with duty factor	
<input checked="" type="checkbox"/> Refer as FCC KDB 789033, clause E Method PM-G (using an RF average power meter).	
<ul style="list-style-type: none"> ▪ For conducted measurement. 	
<ul style="list-style-type: none"> ▪ If the EUT supports multiple transmit chains using options given below: Refer as FCC KDB 662911, In-band power measurements. Using the measure-and-sum approach, measured all transmit ports individually. Sum the power (in linear power units e.g., mW) of all ports for each individual sample and save them. 	
<ul style="list-style-type: none"> ▪ If multiple transmit chains, EIRP calculation could be following as methods: $P_{total} = P_1 + P_2 + \dots + P_n$ (calculated in linear unit [mW] and transfer to log unit [dBm]) $EIRP_{total} = P_{total} + DG$ 	

3.3.4 Test Setup

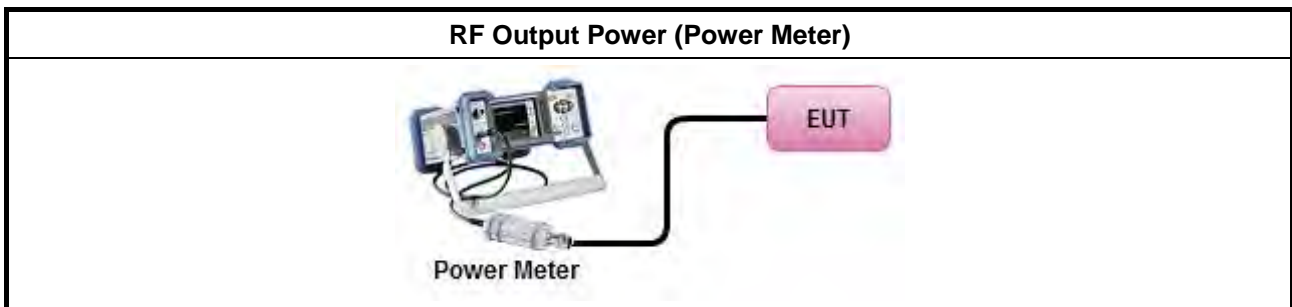

3.3.5 Test Result of Maximum Conducted Output Power

Refer as Appendix C



3.4 Peak Power Spectral Density

3.4.1 Peak Power Spectral Density Limit

Peak Power Spectral Density Limit	
UNII Devices	
<input checked="" type="checkbox"/> For the 5.15-5.25 GHz band:	
	<ul style="list-style-type: none"> ▪ Outdoor AP: the peak power spectral density (PPSD) shall not exceed the lesser of 17dBm/MHz. If $G_{TX} > 6$ dBi, then $P_{Out} = 17 - (G_{TX} - 6)$. ▪ Indoor AP: the peak power spectral density (PPSD) shall not exceed the lesser of 17dBm/MHz. If $G_{TX} > 6$ dBi, then $P_{Out} = 17 - (G_{TX} - 6)$. ▪ Point-to-point AP: the peak power spectral density (PPSD) shall not exceed the lesser of 17dBm/MHz. If $G_{TX} > 23$ dBi, then $P_{Out} = 17 - (G_{TX} - 23)$. ▪ Mobile or Portable Client: the peak power spectral density (PPSD) ≤ 11 dBm/MHz. If $G_{TX} > 6$ dBi, then $PPSD = 11 - (G_{TX} - 6)$.
<input type="checkbox"/> For the 5.25-5.35 GHz band, the peak power spectral density (PPSD) ≤ 11 dBm/MHz. If $G_{TX} > 6$ dBi, then $PPSD = 11 - (G_{TX} - 6)$.	
<input type="checkbox"/> For the 5.47-5.725 GHz band, the peak power spectral density (PPSD) ≤ 11 dBm/MHz. If $G_{TX} > 6$ dBi, then $PPSD = 11 - (G_{TX} - 6)$.	
<input checked="" type="checkbox"/> For the 5.725-5.85 GHz band:	
	<ul style="list-style-type: none"> ▪ Point-to-multipoint systems (P2M): the peak power spectral density (PPSD) ≤ 30 dBm/500kHz. If $G_{TX} > 6$ dBi, then $PPSD = 30 - (G_{TX} - 6)$. ▪ Point-to-point systems (P2P): the peak power spectral density (PPSD) ≤ 30 dBm/500kHz.
LE-LAN Devices	
<input type="checkbox"/> For the 5.15-5.25 GHz band, the e.i.r.p. peak power spectral density (PPSD) ≤ 10 dBm/MHz.	
<input type="checkbox"/> For the 5.25-5.35 GHz band, the peak power spectral density (PPSD) ≤ 11 dBm/MHz.	
	<ul style="list-style-type: none"> ▪ e.i.r.p. greater than 200 mW shall comply with the following e.i.r.p. at different elevations, where θ is the angle above the local horizontal plane (of the Earth) as shown below: -13 dBW/MHz for $0^\circ \leq \theta < 8^\circ$; -13 - 0.716 ($\theta-8$) dBW/MHz for $8^\circ \leq \theta < 40^\circ$ -35.9 - 1.22 ($\theta-40$) dBW/MHz for $40^\circ \leq \theta \leq 45^\circ$; -42 dBW/MHz for $\theta > 45^\circ$
<input type="checkbox"/> For the 5.47-5.6 GHz band and 5.65-5.725 GHz band, the peak power spectral density (PPSD) ≤ 11 dBm/MHz.	
<input type="checkbox"/> For the 5.725-5.85 GHz band:	
	<ul style="list-style-type: none"> ▪ Point-to-multipoint systems (P2M): the peak power spectral density (PPSD) ≤ 30 dBm/500kHz. If $G_{TX} > 6$ dBi, then $PPSD = 30 - (G_{TX} - 6)$. ▪ Point-to-point systems (P2P): the peak power spectral density (PPSD) ≤ 30 dBm/500kHz.
<p>PPSD = peak power spectral density that he same method as used to determine the conducted output power shall be used to determine the power spectral density. And power spectral density in dBm/MHz G_{TX} = the maximum transmitting antenna directional gain in dBi.</p>	

3.4.2 Measuring Instruments

Refer a test equipment and calibration data table in this test report.



3.4.3 Test Procedures

Test Method	
<ul style="list-style-type: none"> ▪ Peak power spectral density procedures that the same method as used to determine the conducted output power shall be used to determine the peak power spectral density and use the peak search function on the spectrum analyzer to find the peak of the spectrum. For the peak power spectral density shall be measured using below options: 	
<input type="checkbox"/>	Refer as FCC KDB 789033, F5) power spectral density can be measured using resolution bandwidths < 1 MHz provided that the results are integrated over 1 MHz bandwidth
[duty cycle ≥ 98% or external video / power trigger]	
<input checked="" type="checkbox"/>	Refer as FCC KDB 789033, clause E Method SA-1 (spectral trace averaging).
<input type="checkbox"/>	Refer as FCC KDB 789033, clause E Method SA-1 Alt. (RMS detection with slow sweep speed)
duty cycle < 98% and average over on/off periods with duty factor	
<input checked="" type="checkbox"/>	Refer as FCC KDB 789033, clause E Method SA-2 (spectral trace averaging).
<input type="checkbox"/>	Refer as FCC KDB 789033, clause E Method SA-2 Alt. (RMS detection with slow sweep speed)
<ul style="list-style-type: none"> ▪ For conducted measurement. 	
<ul style="list-style-type: none"> ▪ If the EUT supports multiple transmit chains using options given below: 	
<input checked="" type="checkbox"/>	Option 1: Measure and sum the spectra across the outputs. Refer as FCC KDB 662911, In-band power spectral density (PSD). Sample all transmit ports simultaneously using a spectrum analyzer for each transmit port. Where the trace bin-by-bin of each transmit port summing can be performed. (i.e., in the first spectral bin of output 1 is summed with that in the first spectral bin of output 2 and that from the first spectral bin of output 3, and so on up to the NTX output to obtain the value for the first frequency bin of the summed spectrum.). Add up the amplitude (power) values for the different transmit chains and use this as the new data trace.
<input type="checkbox"/>	Option 2: Measure and sum spectral maxima across the outputs. With this technique, spectra are measured at each output of the device at the required resolution bandwidth. The maximum value (peak) of each spectrum is determined. These maximum values are then summed mathematically in linear power units across the outputs. These operations shall be performed separately over frequency spans that have different out-of-band or spurious emission limits,
<input type="checkbox"/>	Option 3: Measure and add 10 log(N) dB, where N is the number of transmit chains. Refer as FCC KDB 662911, In-band power spectral density (PSD). Performed at each transmit chains and each transmit chains shall be compared with the limit have been reduced with 10 log(N). Or each transmit chains shall be add 10 log(N) to compared with the limit.
<ul style="list-style-type: none"> ▪ If multiple transmit chains, EIRP PPSD calculation could be following as methods: $PPSD_{total} = PPSD_1 + PPSD_2 + \dots + PPSD_n$ (calculated in linear unit [mW] and transfer to log unit [dBm]) $EIRP_{total} = PPSD_{total} + DG$ 	

3.4.4 Test Setup

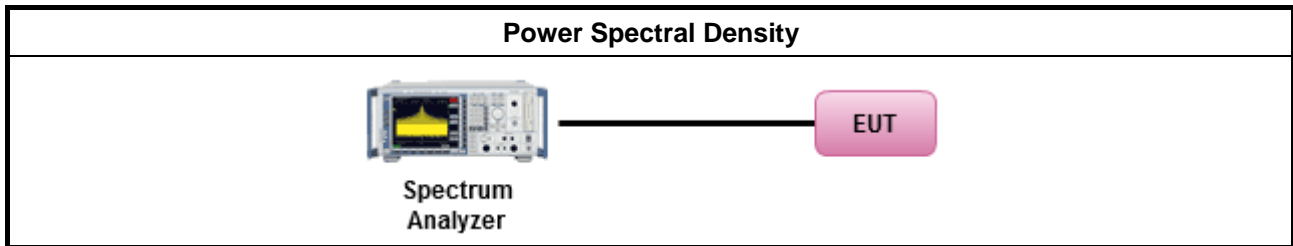

3.4.5 Test Result of Peak Power Spectral Density

Refer as Appendix D



3.5 Unwanted Emissions

3.5.1 Transmitter Unwanted Emissions Limit

Unwanted emissions below 1 GHz and restricted band emissions above 1GHz limit			
Frequency Range (MHz)	Field Strength (uV/m)	Field Strength (dBuV/m)	Measure Distance (m)
0.009~0.490	2400/F(kHz)	48.5 - 13.8	300
0.490~1.705	24000/F(kHz)	33.8 - 23	30
1.705~30.0	30	29	30
30~88	100	40	3
88~216	150	43.5	3
216~960	200	46	3
Above 960	500	54	3

Note 1: Test distance for frequencies at or above 30 MHz, measurements may be performed at a distance other than the limit distance provided they are not performed in the near field and the emissions to be measured can be detected by the measurement equipment. When performing measurements at a distance other than that specified, the results shall be extrapolated to the specified distance using an extrapolation factor of 20 dB/decade (inverse of linear distance for field-strength measurements, inverse of linear distance-squared for power-density measurements).

Note 2: Test distance for frequencies at below 30 MHz, measurements may be performed at a distance closer than the EUT limit distance; however, an attempt should be made to avoid making measurements in the near field. When performing measurements below 30 MHz at a closer distance than the limit distance, the results shall be extrapolated to the specified distance by either making measurements at a minimum of two or more distances on at least one radial to determine the proper extrapolation factor or by using the square of an inverse linear distance extrapolation factor (40 dB/decade). The test report shall specify the extrapolation method used to determine compliance of the EUT.

Note 3: Using the distance of 1m during the test for above 18 GHz, and the test value to correct for the distance factor at 3m.

Un-restricted band emissions above 1GHz Limit	
Operating Band	Limit
<input checked="" type="checkbox"/> 5.15 - 5.25 GHz	e.i.r.p. -27 dBm [68.2 dBuV/m@3m]
<input type="checkbox"/> 5.25 - 5.35 GHz	e.i.r.p. -27 dBm [68.2 dBuV/m@3m]
<input type="checkbox"/> 5.47 - 5.725 GHz	e.i.r.p. -27 dBm [68.2 dBuV/m@3m]
<input checked="" type="checkbox"/> 5.725 - 5.85 GHz	all emissions shall be limited to a level of -27 dBm/MHz at 75 MHz or more above or below the band edge increasing linearly to 10 dBm/MHz at 25 MHz above or below the band edge, and from 25 MHz above or below the band edge increasing linearly to a level of 15.6 dBm/MHz at 5 MHz above or below the band edge, and from 5 MHz above or below the band edge increasing linearly to a level of 27 dBm/MHz at the band edge.

Note 1: Measurements may be performed at a distance other than the limit distance provided they are not performed in the near field and the emissions to be measured can be detected by the measurement equipment. When performing measurements at a distance other than that specified, the results shall be extrapolated to the specified distance using an extrapolation factor of 20 dB/decade (inverse of



linear distance for field-strength measurements, inverse of linear distance-squared for power-density measurements).

3.5.2 Measuring Instruments

Refer a test equipment and calibration data table in this test report.

3.5.3 Test Procedures

Test Method	
	<ul style="list-style-type: none"> ▪ Measurements may be performed at a distance other than the limit distance provided they are not performed in the near field and the emissions to be measured can be detected by the measurement equipment. Measurements shall not be performed at a distance greater than 30 m for frequencies above 30 MHz, unless it can be further demonstrated that measurements at a distance of 30 m or less are impractical. When performing measurements at a distance other than that specified, the results shall be extrapolated to the specified distance using an extrapolation factor of 20 dB/decade (inverse of linear distance for field-strength measurements, inverse of linear distance-squared for power-density measurements).
	<ul style="list-style-type: none"> ▪ The average emission levels shall be measured in [duty cycle ≥ 98 or duty factor].
	<ul style="list-style-type: none"> ▪ For the transmitter unwanted emissions shall be measured using following options below: <ul style="list-style-type: none"> ▪ Refer as FCC KDB 789033, clause G)2) for unwanted emissions into non-restricted bands. ▪ Refer as FCC KDB 789033, clause G)1) for unwanted emissions into restricted bands. <ul style="list-style-type: none"> <input type="checkbox"/> Refer as FCC KDB 789033, G)6) Method AD (Trace Averaging). <input checked="" type="checkbox"/> Refer as FCC KDB 789033, G)6) Method VB (Reduced VBW). <input type="checkbox"/> Refer as ANSI C63.10, clause 11.12.2.5.3 (Reduced VBW). VBW ≥ 1/T, where T is pulse time. <input type="checkbox"/> Refer as ANSI C63.10, clause 7.5 average value of pulsed emissions. <input checked="" type="checkbox"/> Refer as FCC KDB 789033, clause G)5) measurement procedure peak limit. <input type="checkbox"/> Refer as ANSI C63.10, clause 4.1.4.2.2 measurement procedure peak limit.
	<ul style="list-style-type: none"> ▪ For radiated measurement. <ul style="list-style-type: none"> ▪ Refer as ANSI C63.10, clause 6.4 for radiated emissions below 30 MHz and test distance is 3m. ▪ Refer as ANSI C63.10, clause 6.5 for radiated emissions 30 MHz to 1 GHz and test distance is 3m. ▪ Refer as ANSI C63.10, clause 6.6 for radiated emissions above 1GHz.
	<ul style="list-style-type: none"> ▪ The any unwanted emissions level shall not exceed the fundamental emission level.
	<ul style="list-style-type: none"> ▪ All amplitude of spurious emissions that are attenuated by more than 20 dB below the permissible value has no need to be reported.

3.5.4 Test Setup

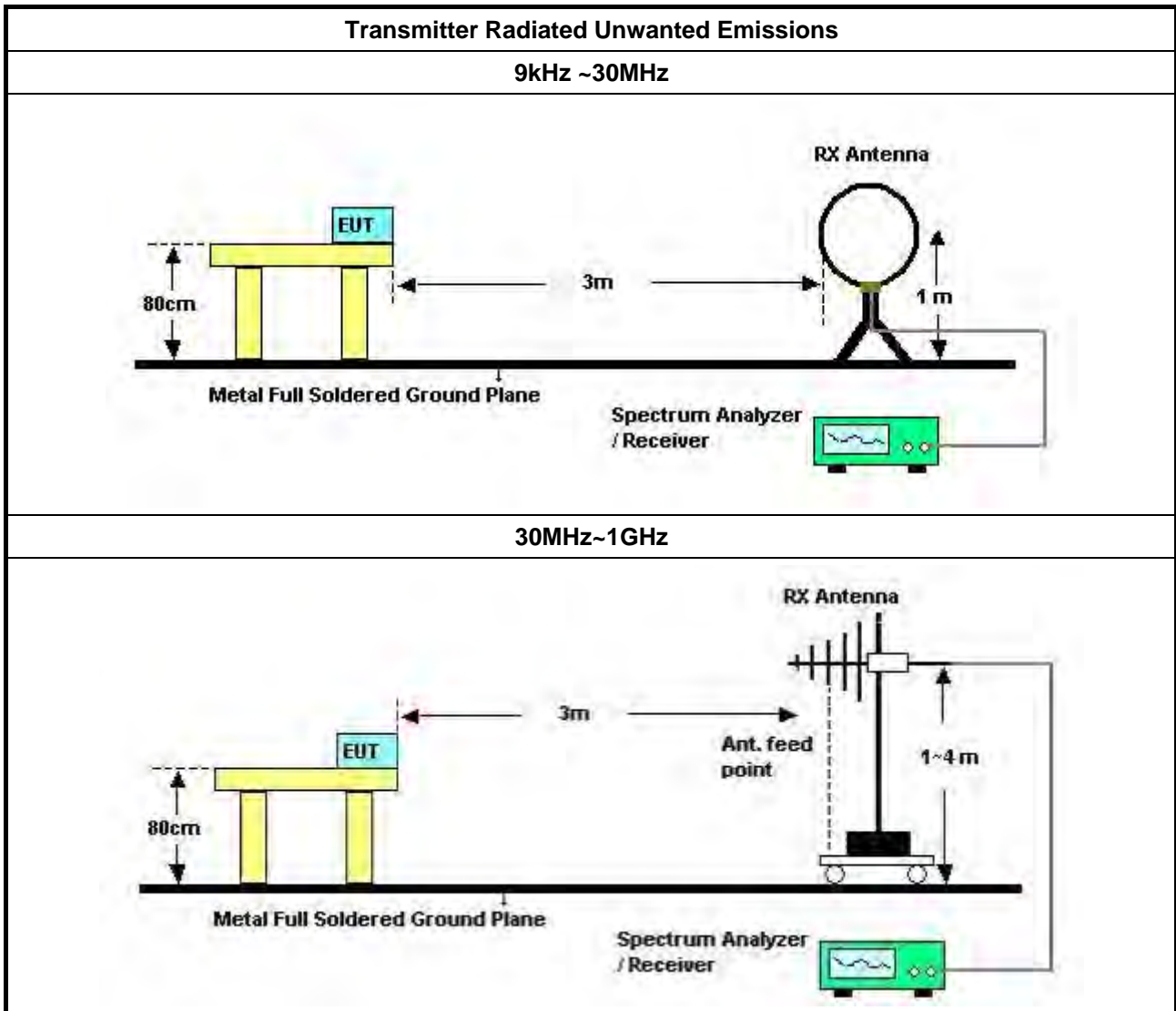

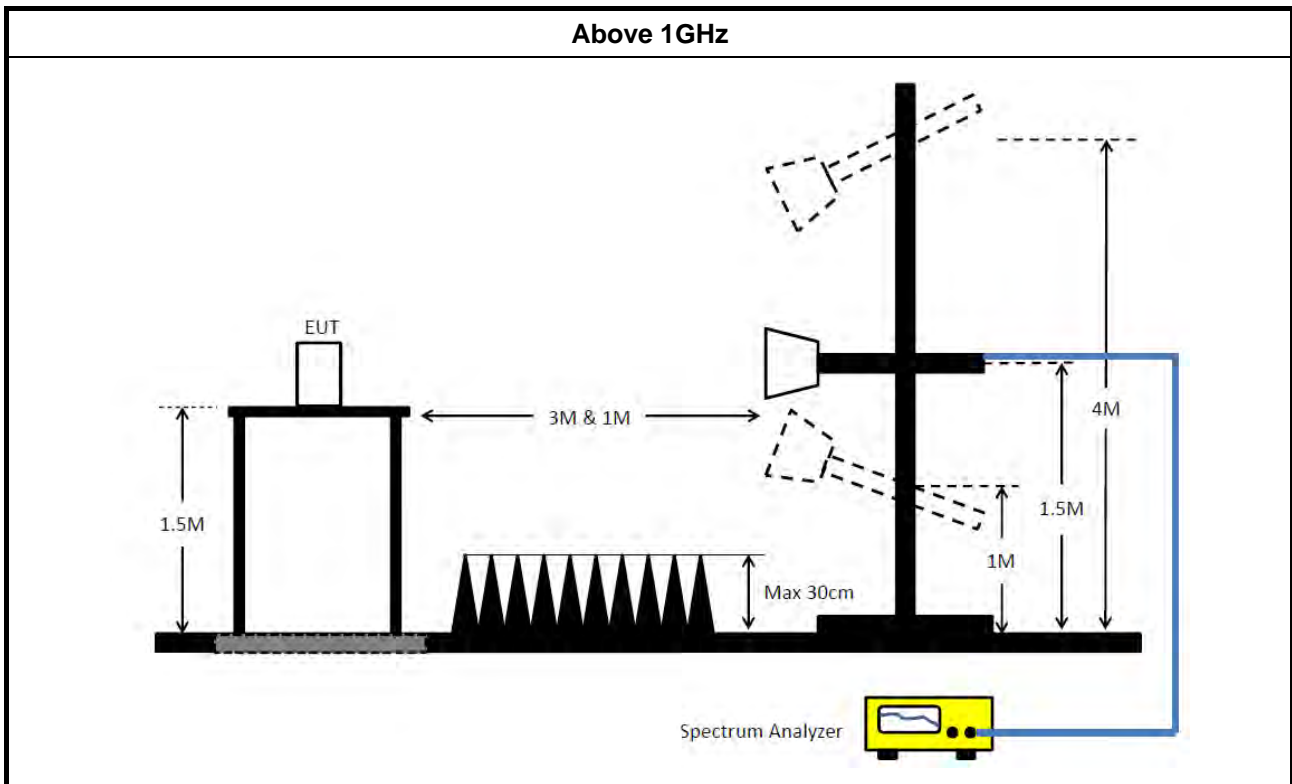

3.5.5 Transmitter Unwanted Emissions (Below 30MHz)

All amplitude of spurious emissions that are attenuated by more than 20 dB below the permissible value has no need to be reported.

The radiated emissions were investigated from 9 kHz or the lowest frequency generated within the device, up to the 10 harmonic or 40 GHz, whichever is appropriate.

3.5.6 Test Result of Transmitter Unwanted Emissions

Refer as Appendix E



4 Test Equipment and Calibration Data

Instrument	Manufacturer	Model No.	Serial No.	Characteristics	Calibration Date	Calibration Due Date	Remark
LISN	Schwarzbeck	NSLK 8127	8127650	9kHz ~ 30MHz	Nov. 21, 2018	Nov. 20, 2019	Conduction (CO02-CB)
LISN	Schwarzbeck	NSLK 8127	8127478	9kHz ~ 30MHz	Nov. 05, 2018	Nov. 04, 2019	Conduction (CO02-CB)
EMI Receiver	Agilent	N9038A	MY52260140	9kHz ~ 8.4GHz	Jan. 17, 2018	Jan. 16, 2019	Conduction (CO02-CB)
COND Cable	Woken	Cable	2	0.15MHz ~ 30MHz	Nov. 06, 2018	Nov. 05, 2019	Conduction (CO02-CB)
Software	Audix	E3	6.120210n	-	N.C.R.	N.C.R.	Conduction (CO02-CB)
BILOG ANTENNA with 6dB Attenuator	TESEQ & EMCI	CBL6112D & N-6-06	37880 & AT-N0609	20MHz ~ 2GHz	Aug. 27, 2018	Aug. 26, 2019	Radiation (03CH01-CB)
Loop Antenna	Teseq	HLA 6120	24155	9kHz - 30 MHz	Mar. 16, 2018	Mar. 15, 2019	Radiation (03CH01-CB)
Loop Antenna	Teseq	HLA 6120	31244	9kHz - 30 MHz	Mar. 18, 2019*	Mar. 17, 2021*	Radiation (03CH01-CB)
Horn Antenna	EMCO	3115	00075790	750MHz ~ 18GHz	Nov. 13, 2018	Nov. 12, 2019	Radiation (03CH01-CB)
Horn Antenna	Schwarzbeck	BBHA 9170	BBHA9170252	15GHz ~ 40GHz	Jun. 28, 2018	Jun. 27, 2019	Radiation (03CH01-CB)
Pre-Amplifier	EMCI	EMC330N	980332	20MHz ~ 3GHz	May 02, 2018	May 01, 2019	Radiation (03CH01-CB)
Pre-Amplifier	Agilent	8449B	3008A02310	1GHz ~ 26.5GHz	Jan. 08, 2019	Jan. 07, 2020	Radiation (03CH01-CB)
Pre-Amplifier	MITEQ	TTA1840-35-HG	1864479	18GHz ~ 40GHz	Jul. 04, 2018	Jul. 03, 2019	Radiation (03CH01-CB)
Spectrum analyzer	R&S	FSP40	100080	9kHz~40GHz	Oct. 03, 2018	Oct. 02, 2019	Radiation (03CH01-CB)
EMI Test Receiver	R&S	ESCS	100359	9kHz ~ 2.75GHz	Jul. 03, 2018	Jul. 02, 2019	Radiation (03CH01-CB)
RF Cable-low	Woken	Low Cable-16+17	N/A	30 MHz ~ 1 GHz	Oct. 08, 2018	Oct. 07, 2019	Radiation (03CH01-CB)
RF Cable-high	Woken	High Cable-16	N/A	1 GHz ~ 18 GHz	Oct. 08, 2018	Oct. 07, 2019	Radiation (03CH01-CB)
RF Cable-high	Woken	High Cable-16+17	N/A	1 GHz ~ 18 GHz	Oct. 08, 2018	Oct. 07, 2019	Radiation (03CH01-CB)
RF Cable-high	Woken	High Cable-40G#1	N/A	18GHz ~ 40 GHz	Jul. 27, 2018	Jul. 26, 2019	Radiation (03CH01-CB)
RF Cable-high	Woken	High Cable-40G#2	N/A	18GHz ~ 40 GHz	Jul. 27, 2018	Jul. 26, 2019	Radiation (03CH01-CB)
Spectrum analyzer	R&S	FSV40	101027	9kHz~40GHz	Jun. 22, 2018	Jun. 21, 2019	Conducted (TH01-CB)
Temp. and Humidity Chamber	Ten Billion	TTH-D3SP	TBN-931011	-30~100 degree	Jun. 01, 2018	May 31, 2019	Conducted (TH01-CB)



Instrument	Manufacturer	Model No.	Serial No.	Characteristics	Calibration Date	Calibration Due Date	Remark
RF Cable-high	Woken	RG402	High Cable-06	1 GHz – 26.5 GHz	Oct. 08, 2018	Oct. 07, 2019	Conducted (TH01-CB)
RF Cable-high	Woken	RG402	High Cable-07	1 GHz –26.5 GHz	Oct. 08, 2018	Oct. 07, 2019	Conducted (TH01-CB)
RF Cable-high	Woken	RG402	High Cable-08	1 GHz –26.5 GHz	Oct. 08, 2018	Oct. 07, 2019	Conducted (TH01-CB)
RF Cable-high	Woken	RG402	High Cable-09	1 GHz –26.5 GHz	Oct. 08, 2018	Oct. 07, 2019	Conducted (TH01-CB)
RF Cable-high	Woken	RG402	High Cable-10	1 GHz –26.5 GHz	Oct. 08, 2018	Oct. 07, 2019	Conducted (TH01-CB)
RF Cable-high	Woken	RG402	High Cable-28	1 GHz –26.5 GHz	Nov. 19, 2018	Nov. 18, 2019	Conducted (TH01-CB)
Power Sensor	Agilent	U2021XA	MY53410001	50MHz~18GHz	Nov. 05, 2018	Nov. 04, 2019	Conducted (TH01-CB)

Note: Calibration Interval of instruments listed above is one year.

*** Calibration Interval of instruments listed above is two years.

N.C.R. means Non-Calibration required.



AC Power-line Conducted Emissions Result

Appendix A

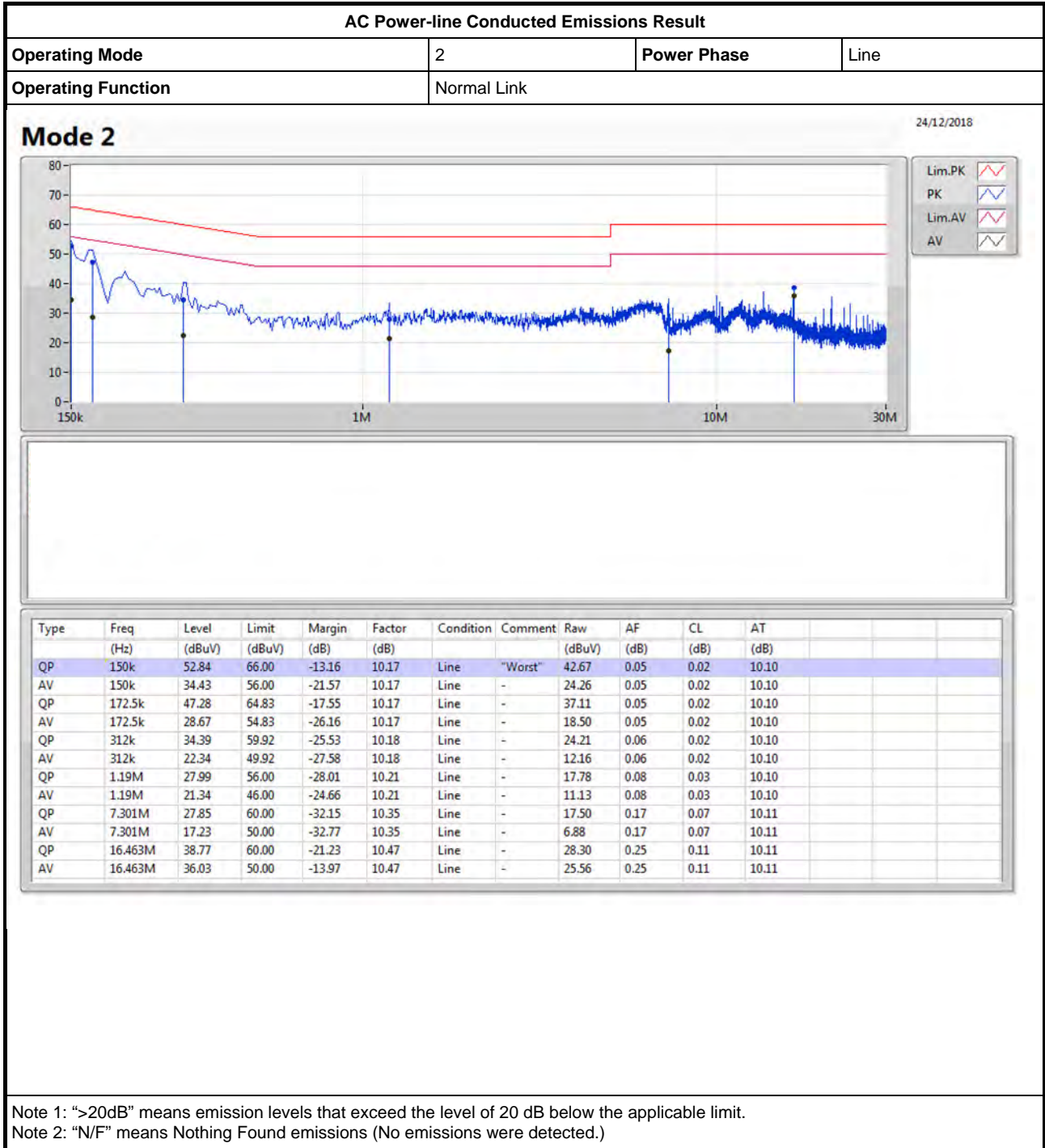



AC Power-line Conducted Emissions Result

Appendix A

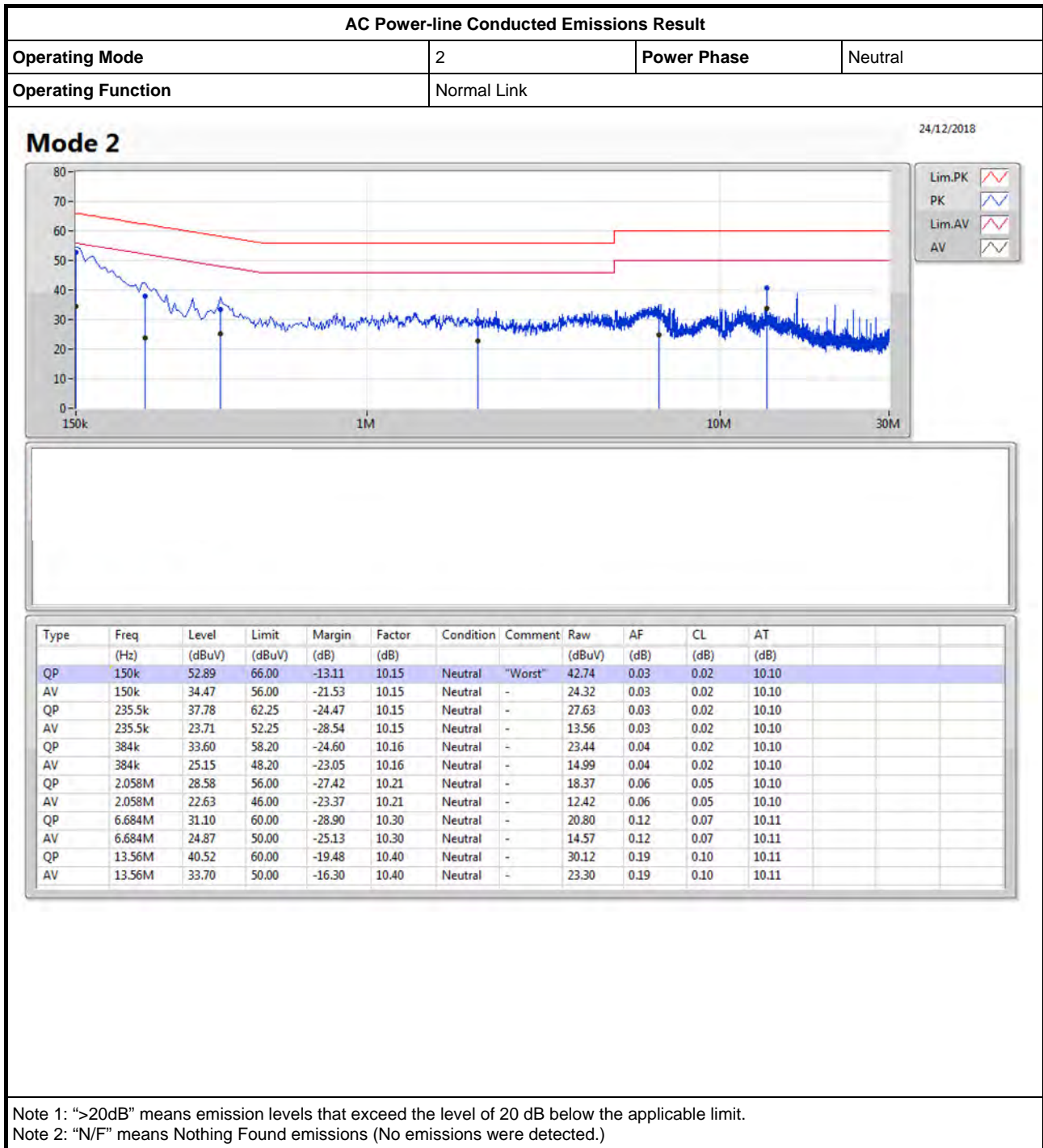



Summary

Mode	Max-N dB (Hz)	Max-OBW (Hz)	ITU-Code	Min-N dB (Hz)	Min-OBW (Hz)
5.15-5.25GHz	-	-	-	-	-
802.11a_Nss1,(6Mbps)_2TX	30.8M	16.717M	16M7D1D	24.35M	16.517M
802.11ac VHT20_Nss1,(MCS0)_2TX	30.975M	17.866M	17M9D1D	23.75M	17.741M
802.11ac VHT40_Nss1,(MCS0)_2TX	69.05M	36.332M	36M3D1D	44.55M	36.182M
802.11ac VHT80_Nss1,(MCS0)_2TX	90.2M	76.062M	76M1D1D	88.4M	75.962M
5.725-5.85GHz	-	-	-	-	-
802.11a_Nss1,(6Mbps)_2TX	16.325M	16.717M	16M7D1D	16.275M	16.542M
802.11ac VHT20_Nss1,(MCS0)_2TX	17.575M	17.891M	17M9D1D	17.15M	17.766M
802.11ac VHT40_Nss1,(MCS0)_2TX	36.3M	36.432M	36M4D1D	35.9M	36.382M
802.11ac VHT80_Nss1,(MCS0)_2TX	76.3M	76.162M	76M2D1D	76M	76.062M

Max-N dB = Maximum 6dB down bandwidth for 5.725-5.85GHz band / Maximum 26dB down bandwidth for other band;

Max-OBW = Maximum 99% occupied bandwidth;

Min-N dB = Minimum 6dB down bandwidth for 5.725-5.85GHz band / Maximum 26dB down bandwidth for other band;

Min-OBW = Minimum 99% occupied bandwidth;



Result

Mode	Result	Limit (Hz)	Port 1-N dB (Hz)	Port 1-OBW (Hz)	Port 2-N dB (Hz)	Port 2-OBW (Hz)
802.11a_Nss1,(6Mbps)_2TX	-	-	-	-	-	-
5180MHz	Pass	Inf	25.775M	16.592M	24.35M	16.517M
5200MHz	Pass	Inf	28.625M	16.667M	25.525M	16.517M
5240MHz	Pass	Inf	30.8M	16.717M	25.725M	16.542M
5745MHz	Pass	500k	16.325M	16.642M	16.3M	16.542M
5785MHz	Pass	500k	16.275M	16.717M	16.325M	16.617M
5825MHz	Pass	500k	16.3M	16.642M	16.3M	16.617M
802.11ac VHT20_Nss1,(MCS0)_2TX	-	-	-	-	-	-
5180MHz	Pass	Inf	28.275M	17.791M	23.75M	17.741M
5200MHz	Pass	Inf	30.975M	17.866M	23.9M	17.791M
5240MHz	Pass	Inf	30.925M	17.791M	26.4M	17.766M
5745MHz	Pass	500k	17.575M	17.841M	17.55M	17.766M
5785MHz	Pass	500k	17.55M	17.891M	17.15M	17.866M
5825MHz	Pass	500k	17.575M	17.841M	17.525M	17.791M
802.11ac VHT40_Nss1,(MCS0)_2TX	-	-	-	-	-	-
5190MHz	Pass	Inf	44.55M	36.182M	44.55M	36.232M
5230MHz	Pass	Inf	69.05M	36.282M	59.8M	36.332M
5755MHz	Pass	500k	36.3M	36.432M	35.9M	36.382M
5795MHz	Pass	500k	36.05M	36.382M	36M	36.432M
802.11ac VHT80_Nss1,(MCS0)_2TX	-	-	-	-	-	-
5210MHz	Pass	Inf	90.2M	76.062M	88.4M	75.962M
5775MHz	Pass	500k	76M	76.062M	76.3M	76.162M

Port X-N dB = Port X 6dB down bandwidth for 5.725-5.85GHz band / 26dB down bandwidth for other band

Port X-OBW = Port X 99% occupied bandwidth;

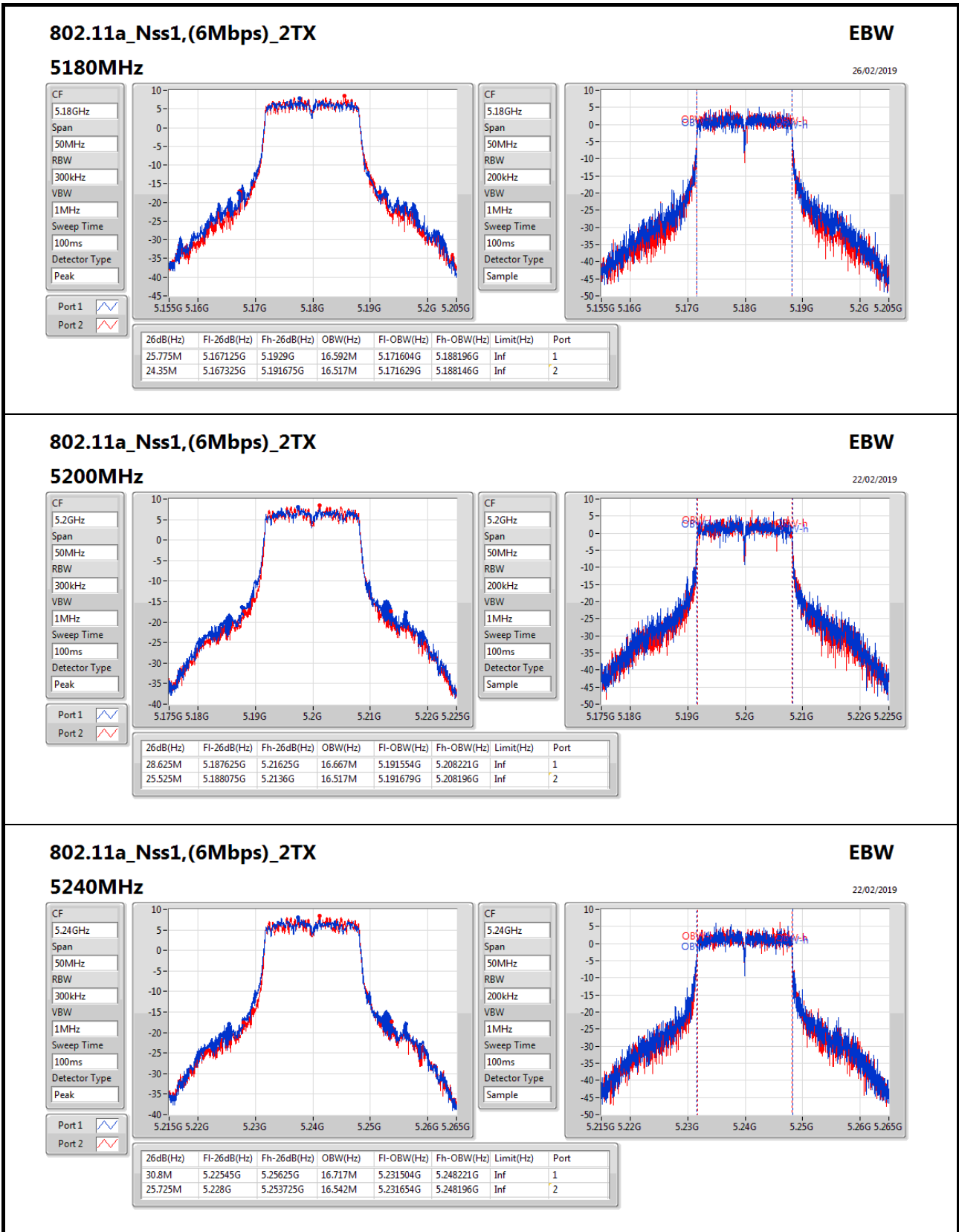

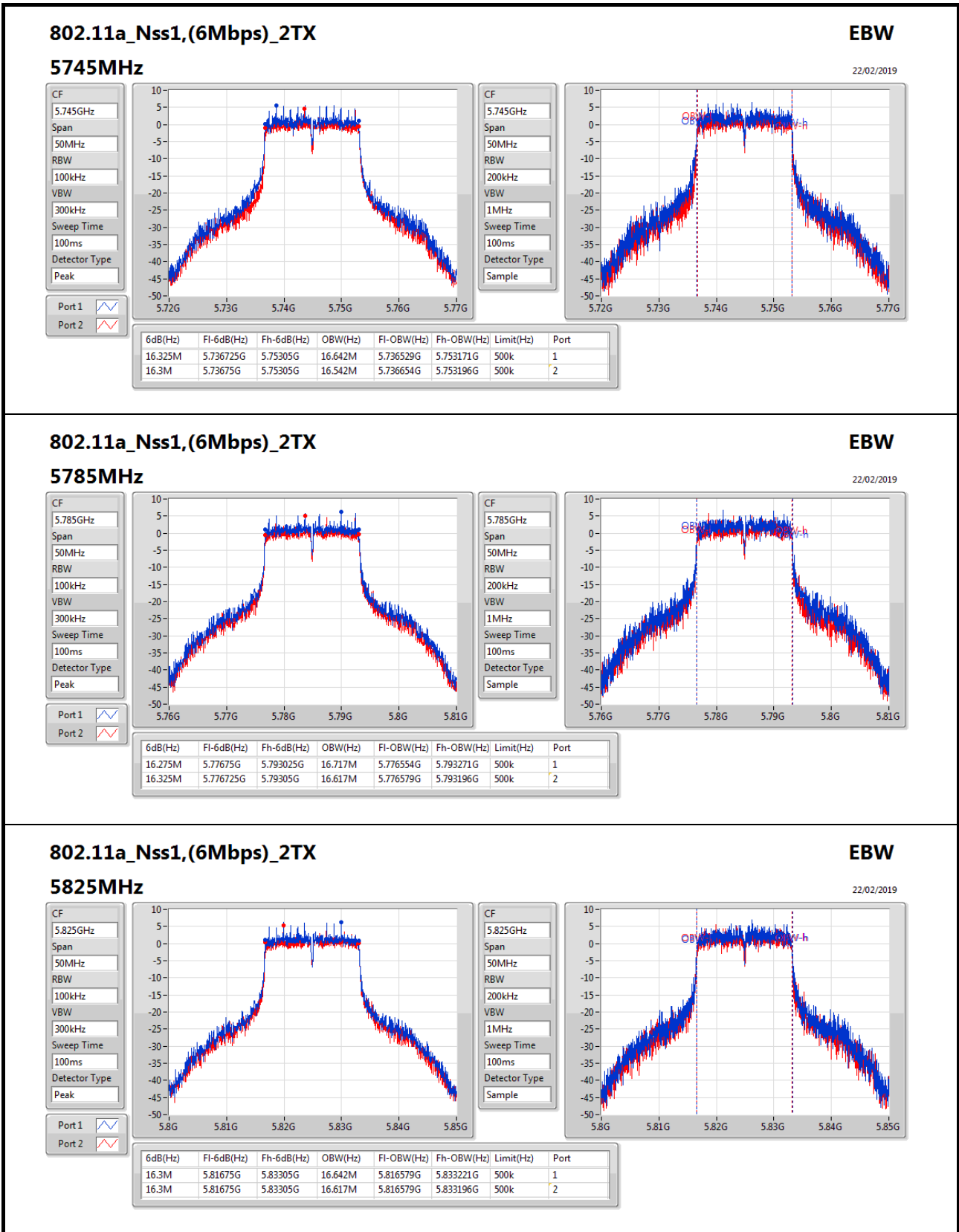

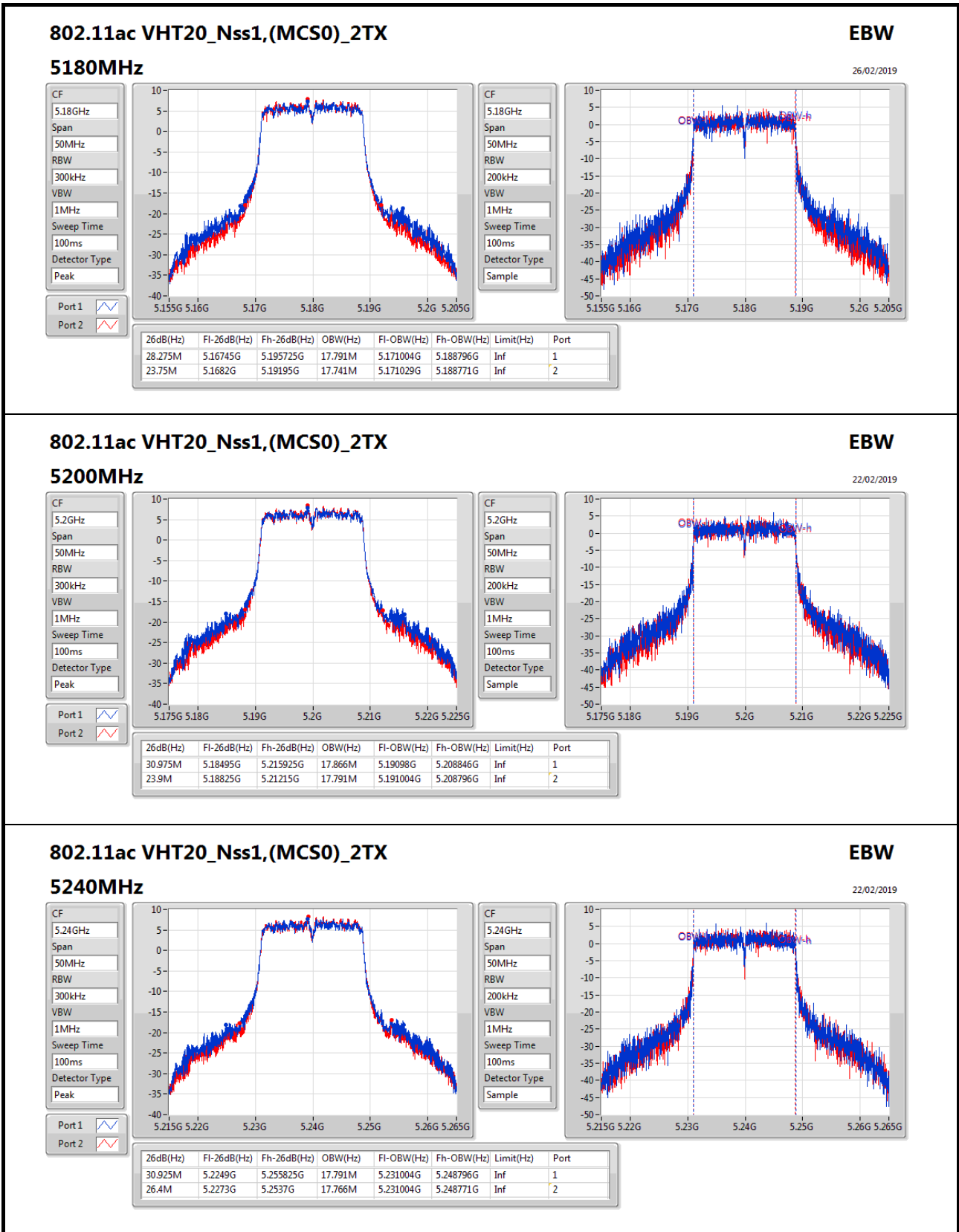

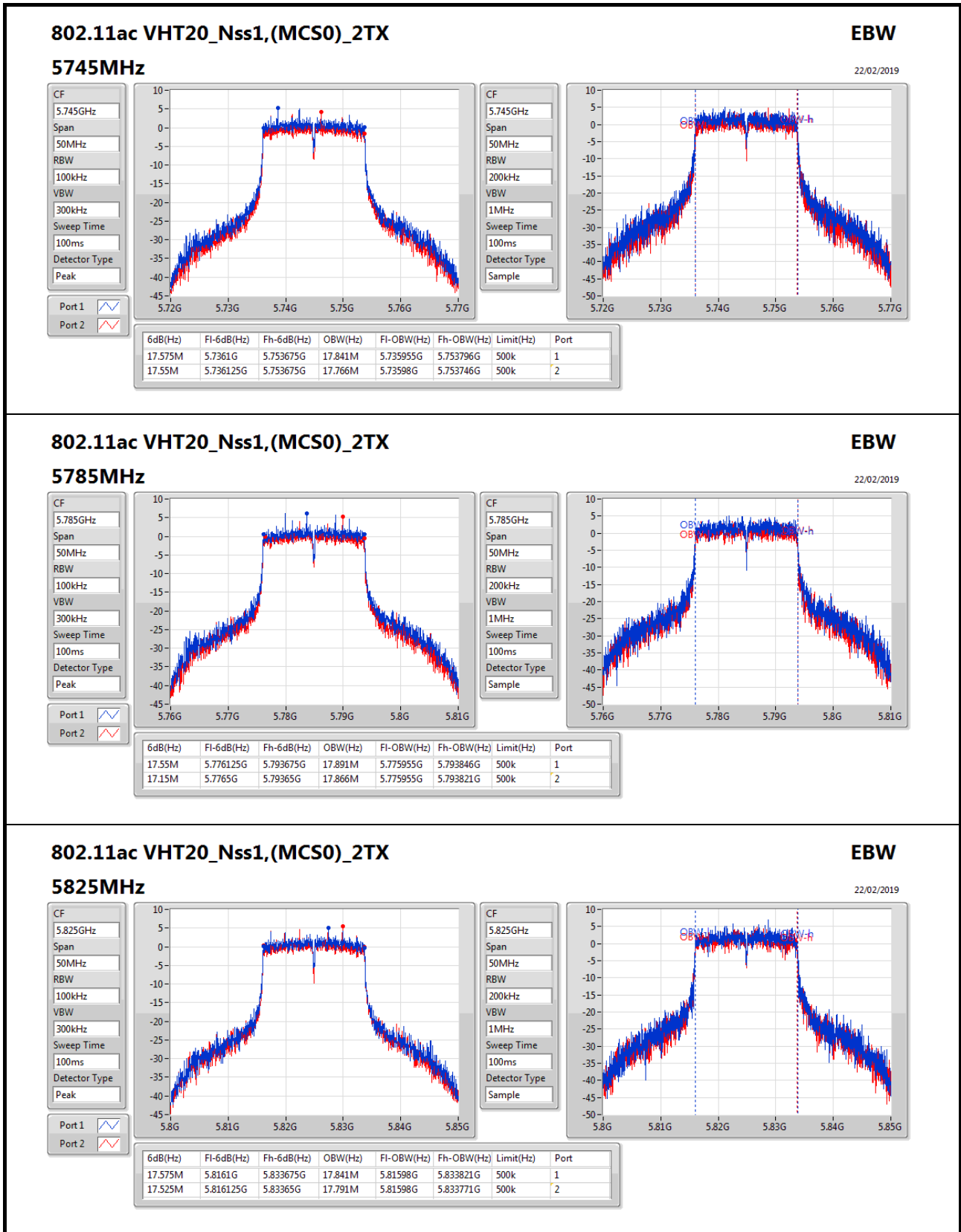

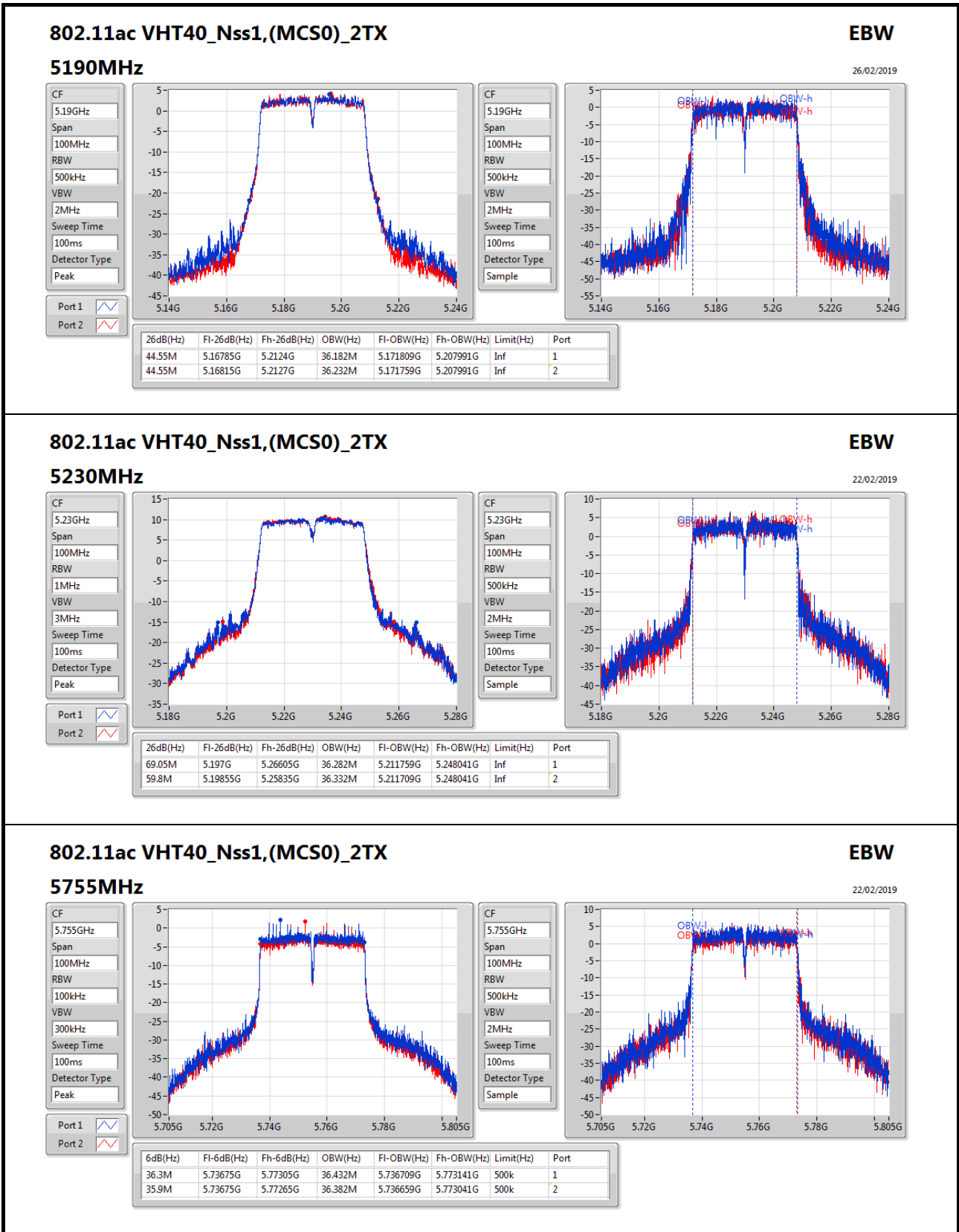

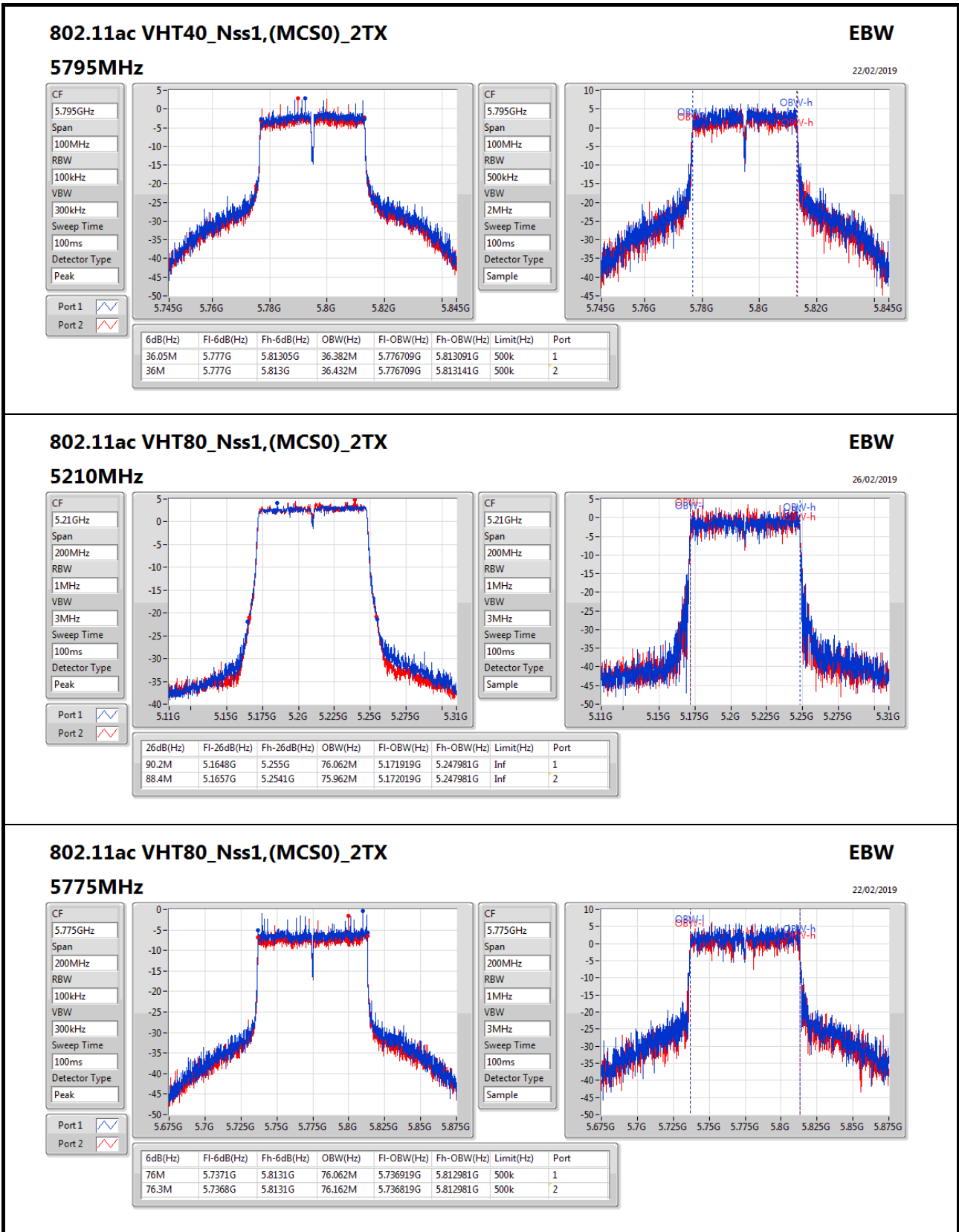



Summary

Mode	Total Power (dBm)	Total Power (W)
5.15-5.25GHz	-	-
802.11a_Nss1,(6Mbps)_2TX	20.26	0.10617
802.11ac VHT20_Nss1,(MCS0)_2TX	20.34	0.10814
802.11ac VHT40_Nss1,(MCS0)_2TX	20.27	0.10641
802.11ac VHT80_Nss1,(MCS0)_2TX	16.62	0.04592
5.725-5.85GHz	-	-
802.11a_Nss1,(6Mbps)_2TX	20.38	0.10914
802.11ac VHT20_Nss1,(MCS0)_2TX	20.47	0.11143
802.11ac VHT40_Nss1,(MCS0)_2TX	20.27	0.10641
802.11ac VHT80_Nss1,(MCS0)_2TX	19.31	0.08531



Result

Mode	Result	DG (dBi)	Port 1 (dBm)	Port 2 (dBm)	Total Power (dBm)	Power Limit (dBm)
802.11a_Nss1,(6Mbps)_2TX	-	-	-	-	-	-
5180MHz	Pass	5.79	16.76	16.68	19.73	30.00
5200MHz	Pass	5.79	17.18	17.23	20.22	30.00
5240MHz	Pass	5.79	17.23	17.26	20.26	30.00
5745MHz	Pass	5.10	17.44	16.44	19.98	30.00
5785MHz	Pass	5.10	17.81	16.70	20.30	30.00
5825MHz	Pass	5.10	17.69	17.03	20.38	30.00
802.11ac VHT20_Nss1,(MCS0)_2TX	-	-	-	-	-	-
5180MHz	Pass	5.79	16.75	16.82	19.80	30.00
5200MHz	Pass	5.79	17.23	17.29	20.27	30.00
5240MHz	Pass	5.79	17.34	17.31	20.34	30.00
5745MHz	Pass	5.10	17.46	16.45	19.99	30.00
5785MHz	Pass	5.10	17.84	16.79	20.36	30.00
5825MHz	Pass	5.10	17.75	17.15	20.47	30.00
802.11ac VHT40_Nss1,(MCS0)_2TX	-	-	-	-	-	-
5190MHz	Pass	5.79	14.22	14.10	17.17	30.00
5230MHz	Pass	5.79	17.22	17.30	20.27	30.00
5755MHz	Pass	5.10	17.15	16.39	19.80	30.00
5795MHz	Pass	5.10	17.72	16.75	20.27	30.00
802.11ac VHT80_Nss1,(MCS0)_2TX	-	-	-	-	-	-
5210MHz	Pass	5.79	13.64	13.58	16.62	30.00
5775MHz	Pass	5.10	16.72	15.84	19.31	30.00

DG = Directional Gain; **Port X** = Port X output power



Summary

Mode	PD (dBm/RBW)
5.15-5.25GHz	-
802.11a_Nss1,(6Mbps)_2TX	7.14
802.11ac VHT20_Nss1,(MCS0)_2TX	7.03
802.11ac VHT40_Nss1,(MCS0)_2TX	4.04
802.11ac VHT80_Nss1,(MCS0)_2TX	-3.08
5.725-5.85GHz	-
802.11a_Nss1,(6Mbps)_2TX	5.72
802.11ac VHT20_Nss1,(MCS0)_2TX	5.74
802.11ac VHT40_Nss1,(MCS0)_2TX	2.56
802.11ac VHT80_Nss1,(MCS0)_2TX	-1.77

RBW = 500kHz for 5.725-5.85GHz band / 1MHz for other band;



Result

Mode	Result	DG (dBi)	Port 1 (dBm/RBW)	Port 2 (dBm/RBW)	PD (dBm/RBW)	PD Limit (dBm/RBW)
802.11a_Nss1,(6Mbps)_2TX	-	-	-	-	-	-
5180MHz	Pass	8.41	3.73	3.73	6.68	14.59
5200MHz	Pass	8.41	4.26	4.36	7.14	14.59
5240MHz	Pass	8.41	4.05	4.41	7.08	14.59
5745MHz	Pass	7.79	2.75	1.84	5.27	28.21
5785MHz	Pass	7.79	2.98	2.12	5.51	28.21
5825MHz	Pass	7.79	2.99	2.52	5.72	28.21
802.11ac VHT20_Nss1,(MCS0)_2TX	-	-	-	-	-	-
5180MHz	Pass	8.41	3.51	3.58	6.48	14.59
5200MHz	Pass	8.41	3.96	4.16	7.03	14.59
5240MHz	Pass	8.41	3.97	4.06	6.94	14.59
5745MHz	Pass	7.79	2.66	1.82	5.18	28.21
5785MHz	Pass	7.79	2.84	2.07	5.41	28.21
5825MHz	Pass	7.79	3.05	2.50	5.74	28.21
802.11ac VHT40_Nss1,(MCS0)_2TX	-	-	-	-	-	-
5190MHz	Pass	8.41	-1.81	-1.89	1.07	14.59
5230MHz	Pass	8.41	0.97	1.23	4.04	14.59
5755MHz	Pass	7.79	-0.57	-1.14	2.14	28.21
5795MHz	Pass	7.79	0.07	-0.96	2.56	28.21
802.11ac VHT80_Nss1,(MCS0)_2TX	-	-	-	-	-	-
5210MHz	Pass	8.41	-5.99	-6.07	-3.08	14.59
5775MHz	Pass	7.79	-4.37	-4.96	-1.77	28.21

DG = Directional Gain; RBW = 500kHz for 5.725-5.85GHz band / 1MHz for other band;

PD = trace bin-by-bin of each transmits port summing can be performed maximum power density; Port X = Port Xpower density;

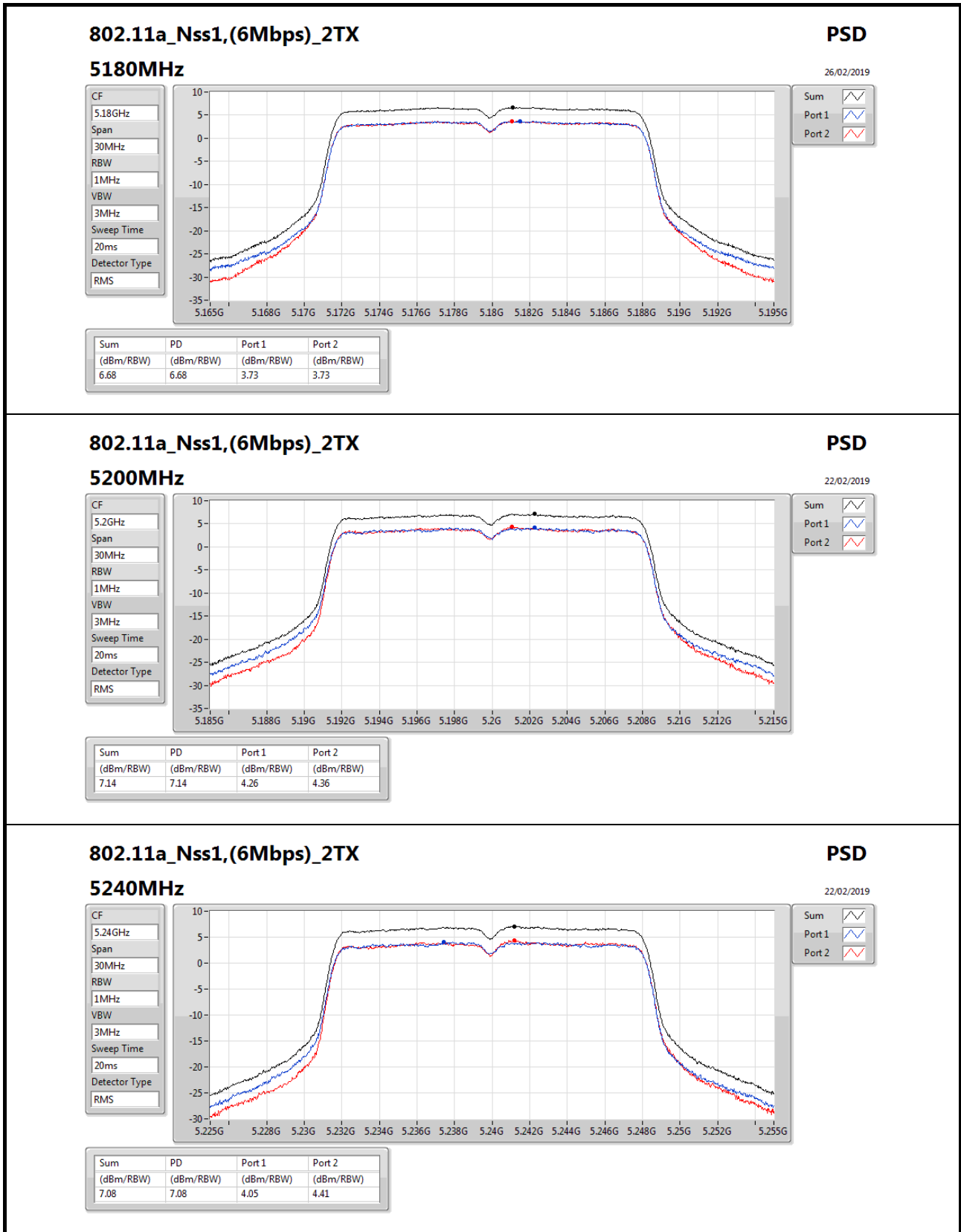

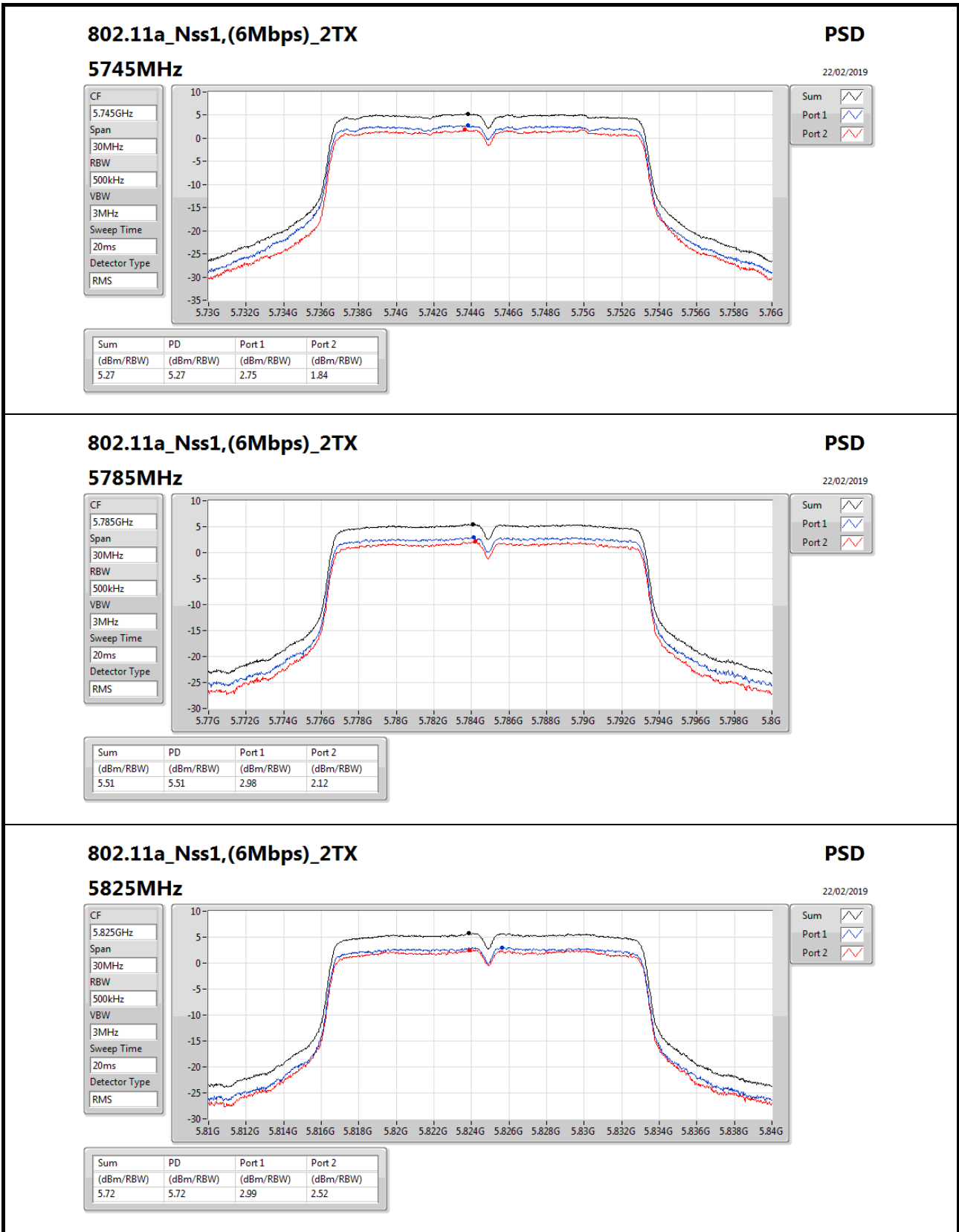

802.11a_Nss1,(6Mbps)_2TX

5825MHz

PSD

22/02/2019

CF
5.825GHz

Span
30MHz

RBW
500kHz

VBW
3MHz

Sweep Time
20ms

Detector Type
RMS

Sum

Port 1

Port 2

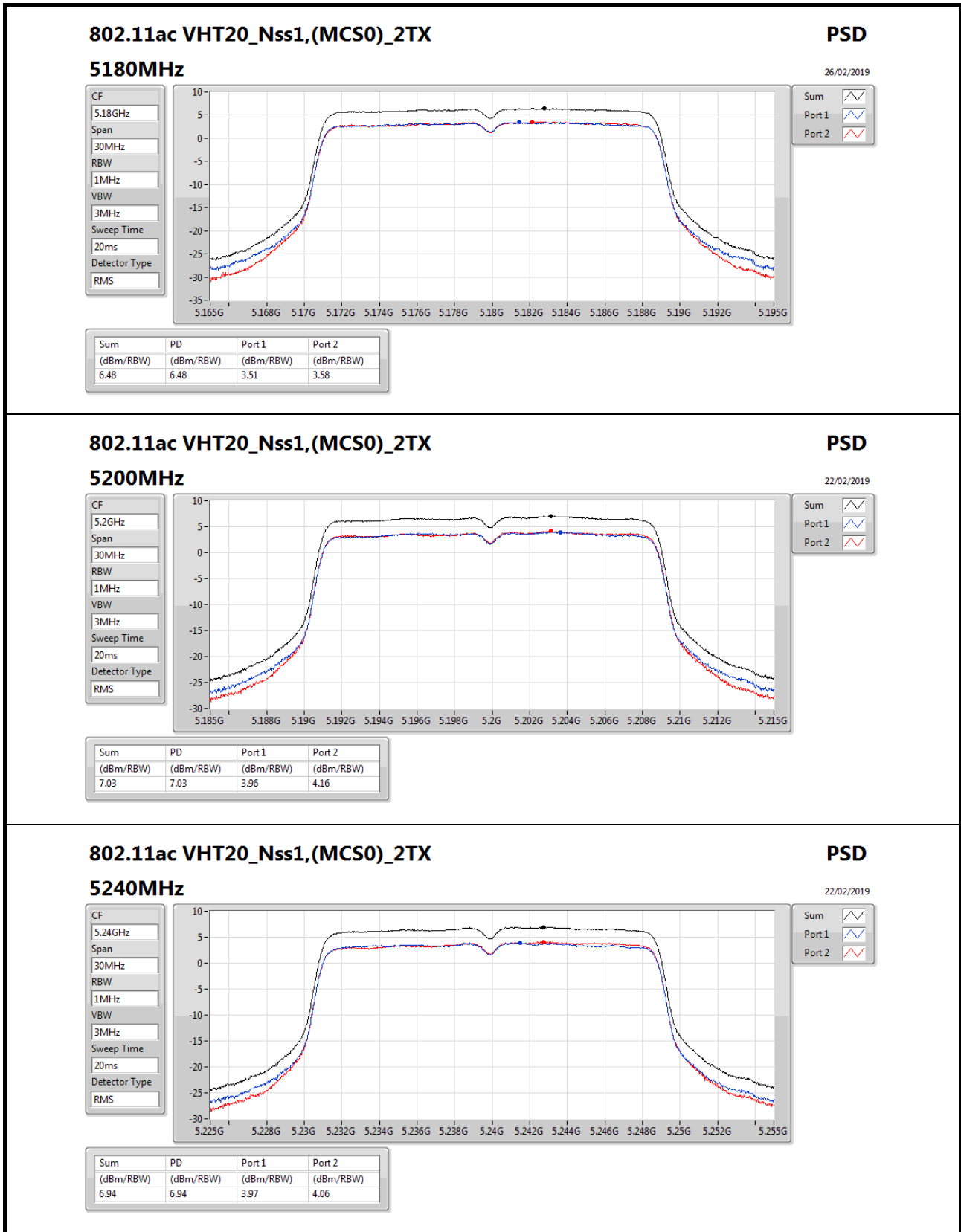

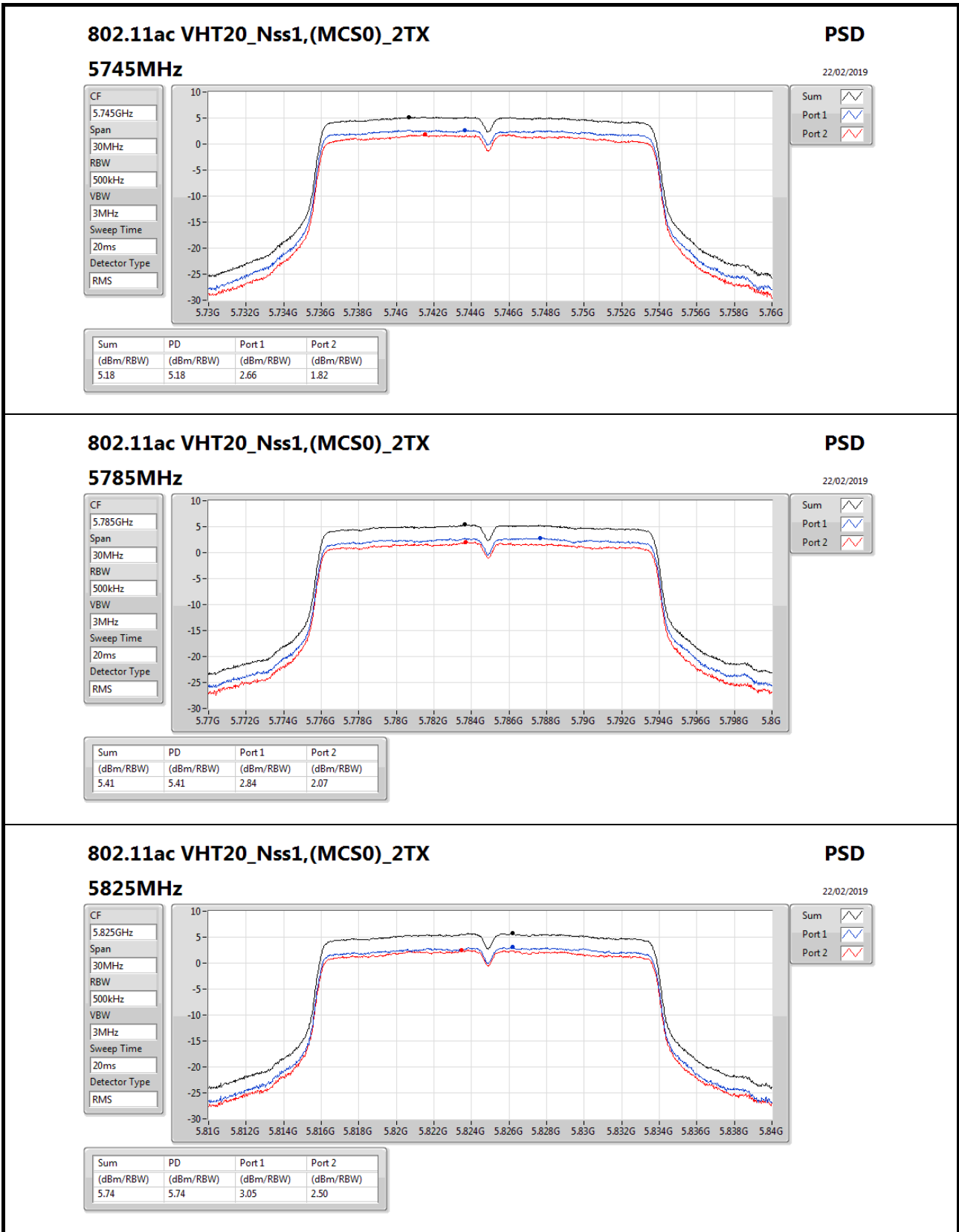

802.11ac VHT20_Nss1,(MCS0)_2TX

5825MHz

PSD

22/02/2019

CF

5.825GHz

Span

30MHz

RBW

500kHz

VBW

3MHz

Sweep Time

20ms

Detector Type

RMS

Sum

Port 1

Port 2

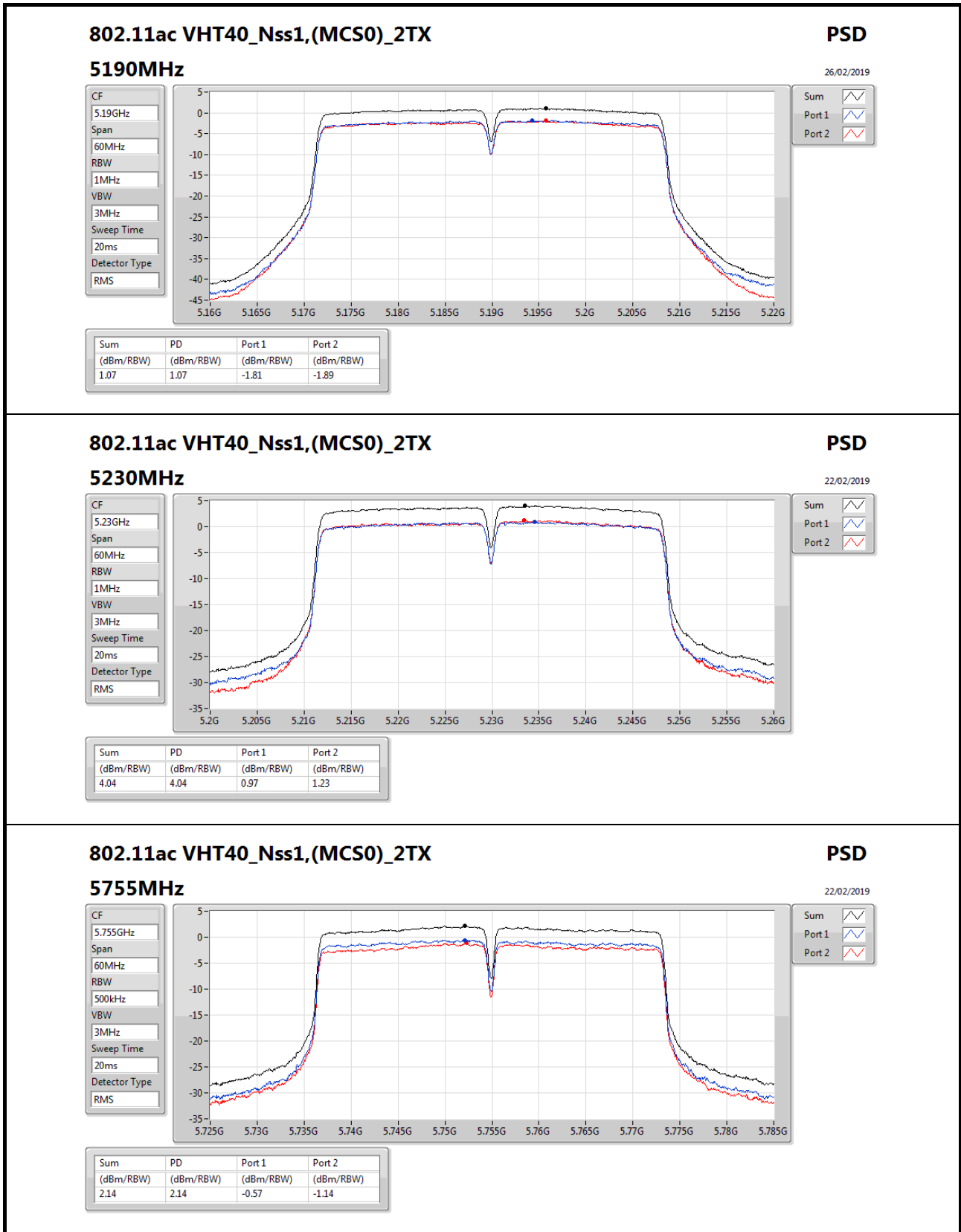

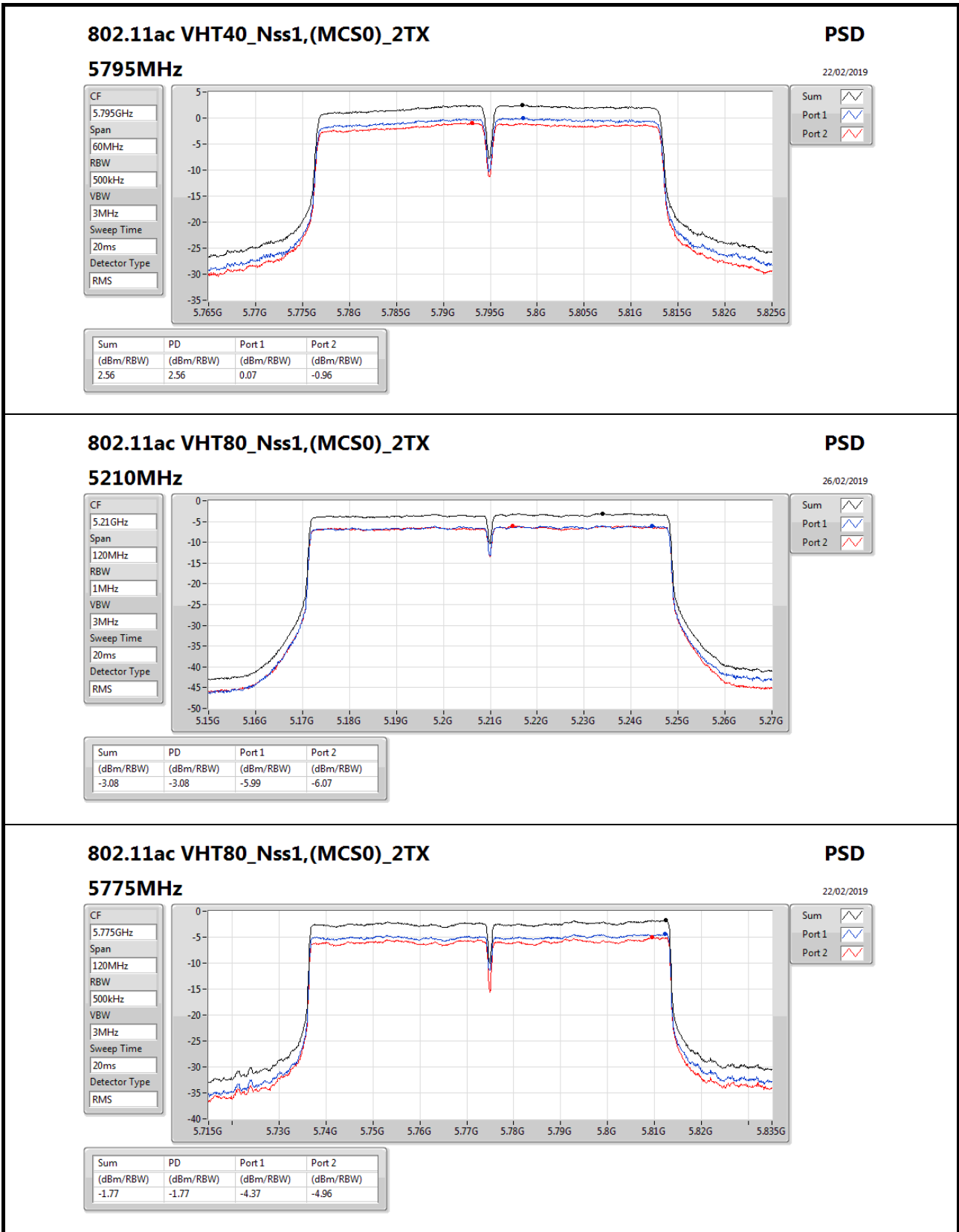



RSE below 1GHz Result

Appendix E.1

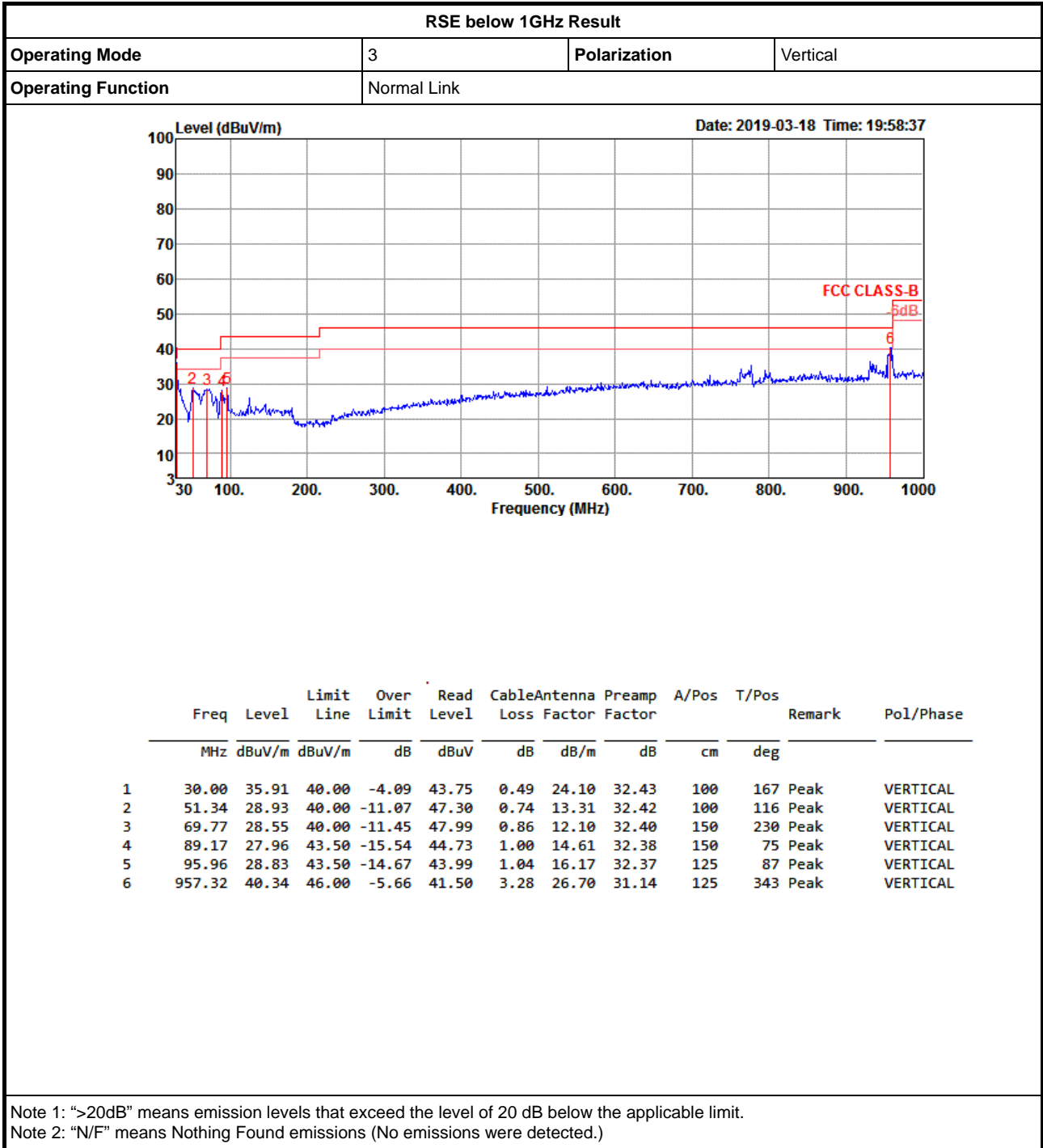



RSE below 1GHz Result

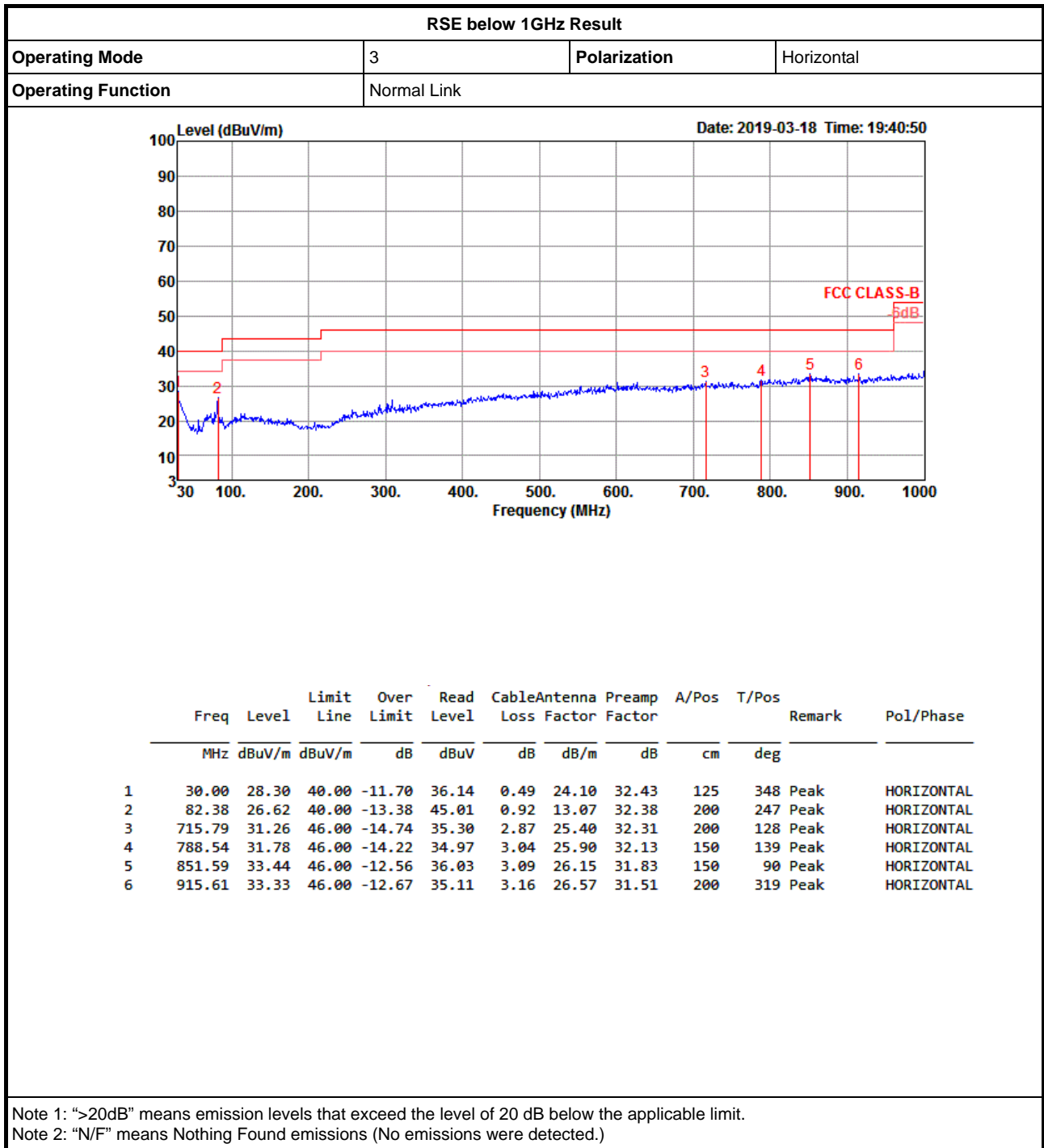



Summary

Mode	Result	Type	Freq (Hz)	Level (dBuV/m)	Limit (dBuV/m)	Margin (dB)	Factor (dB)	Dist (m)	Condition	Azimuth (°)	Height (m)	Comments
5.725-5.85GHz	-	-	-	-	-	-	-	-	-	-	-	-
802.11ac VHT40_Nss1,(MCS0)_2TX	Pass	PK	5.6495G	67.19	68.20	-1.01	6.37	3	Horizontal	334	1.01	-

802.11a_Nss1,(6Mbps)_2TX

25/02/2019

5180MHz_TX

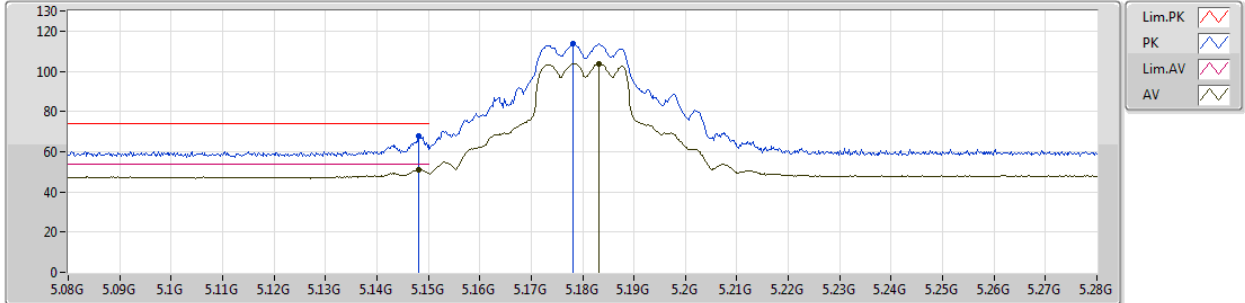

EUT_Z_2TX
Setting 16.5
06-K-3-10
FSP



Type	Freq (Hz)	Level (dBuV/m)	Limit (dBuV/m)	Margin (dB)	Factor (dB)	Dist (m)	Condition	Azimuth (°)	Height (m)	Comments
PK	5.1482G	67.70	74.00	-6.30	7.27	3	Vertical	237	2.93	-
AV	5.1482G	50.98	54.00	-3.02	7.27	3	Vertical	237	2.93	-
PK	5.1782G	113.66	Inf	-Inf	7.33	3	Vertical	237	2.93	-
AV	5.1832G	103.89	Inf	-Inf	7.33	3	Vertical	237	2.93	-

802.11a_Nss1,(6Mbps)_2TX

25/02/2019

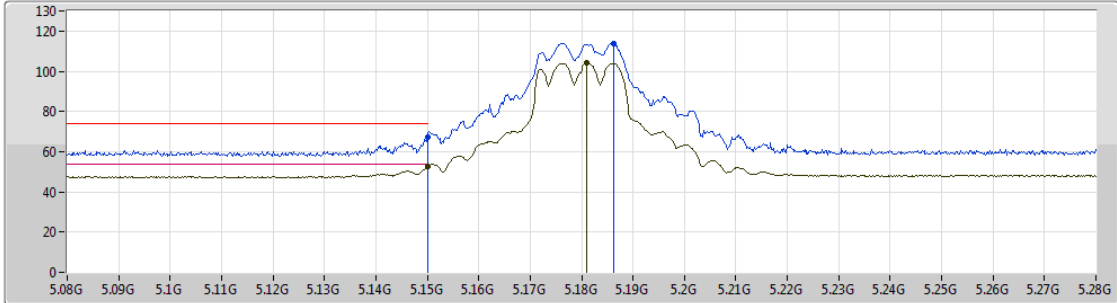
5180MHz_TX



Lim.PK 
 PK 
 Lim.AV 
 AV 

EUT_Z_2TX
 Setting 16.5
 06-K-3-10
 FSP

Type	Freq (Hz)	Level (dBuV/m)	Limit (dBuV/m)	Margin (dB)	Factor (dB)	Dist (m)	Condition	Azimuth (°)	Height (m)	Comments
PK	5.15G	67.19	74.00	-6.81	7.27	3	Horizontal	345	1.00	-
AV	5.15G	52.67	54.00	-1.33	7.27	3	Horizontal	345	1.00	-
PK	5.1862G	113.84	Inf	-Inf	7.34	3	Horizontal	345	1.00	-
AV	5.181G	104.25	Inf	-Inf	7.33	3	Horizontal	345	1.00	-

802.11a_Nss1,(6Mbps)_2TX

13/02/2019

5180MHz_TX

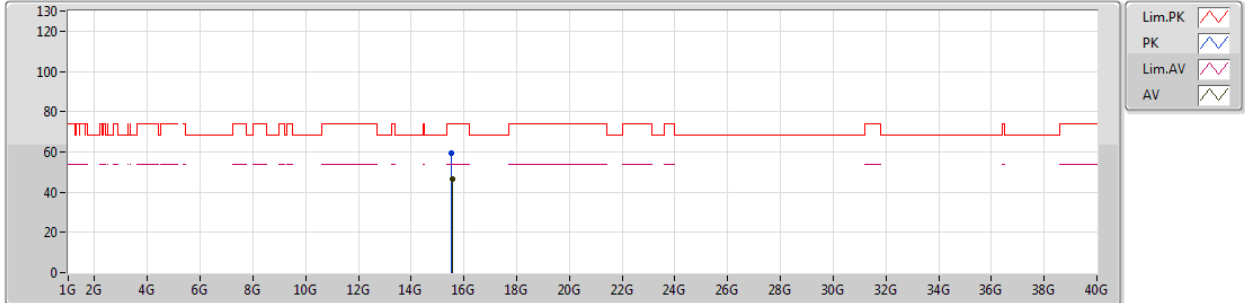

EUT_Z_2TX
Setting 17
03-E-2
FSP

Type	Freq (Hz)	Level (dBuV/m)	Limit (dBuV/m)	Margin (dB)	Factor (dB)	Dist (m)	Condition	Azimuth (°)	Height (m)	Comments
PK	15.52944G	59.43	74.00	-14.57	15.30	3	Vertical	58	2.67	-
AV	15.55434G	46.67	54.00	-7.33	15.21	3	Vertical	58	2.67	-

802.11a_Nss1,(6Mbps)_2TX

13/02/2019

5180MHz_TX

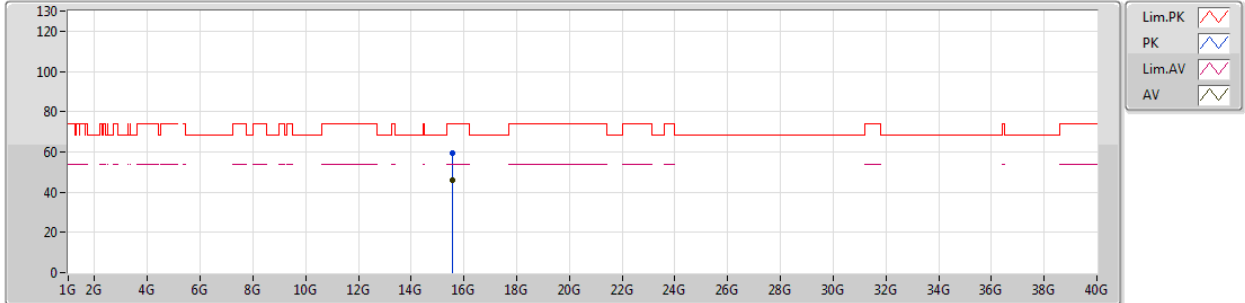

EUT_Z_2TX
Setting 17
03-E-2
FSP

Type	Freq (Hz)	Level (dBuV/m)	Limit (dBuV/m)	Margin (dB)	Factor (dB)	Dist (m)	Condition	Azimuth (°)	Height (m)	Comments
PK	15.54975G	59.35	74.00	-14.65	15.22	3	Horizontal	332	2.49	-
AV	15.55299G	46.03	54.00	-7.97	15.21	3	Horizontal	332	2.49	-

802.11a_Nss1,(6Mbps)_2TX

25/02/2019

5200MHz_TX

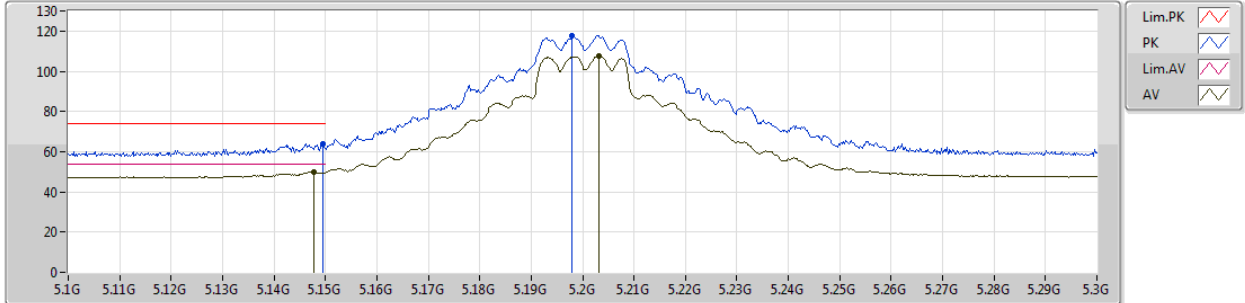

EUT_Z_2TX
Setting 20.5
06-K-3-10
FSP

Type	Freq (Hz)	Level (dBuV/m)	Limit (dBuV/m)	Margin (dB)	Factor (dB)	Dist (m)	Condition	Azimuth (°)	Height (m)	Comments
PK	5.1496G	64.02	74.00	-9.98	7.27	3	Vertical	237	2.90	-
AV	5.1478G	49.81	54.00	-4.19	7.27	3	Vertical	237	2.90	-
PK	5.198G	117.66	Inf	-Inf	7.36	3	Vertical	237	2.90	-
AV	5.2032G	107.73	Inf	-Inf	7.36	3	Vertical	237	2.90	-

802.11a_Nss1,(6Mbps)_2TX

25/02/2019

5200MHz_TX

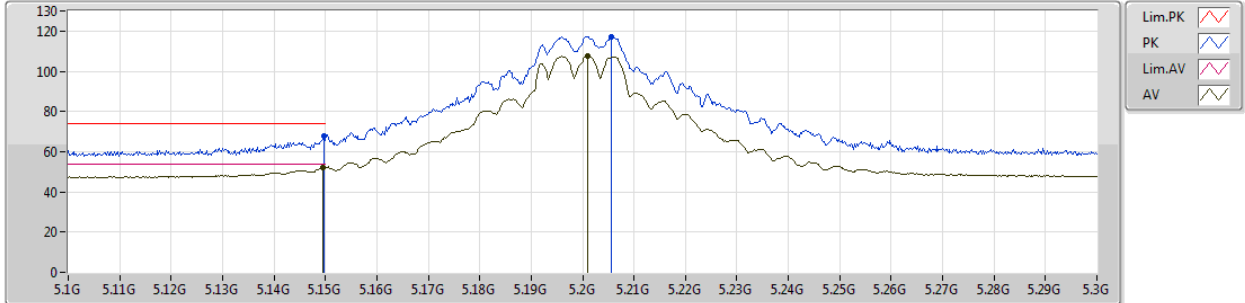

EUT_Z_2TX
Setting 20.5
06-K-3-10
FSP

Type	Freq (Hz)	Level (dBuV/m)	Limit (dBuV/m)	Margin (dB)	Factor (dB)	Dist (m)	Condition	Azimuth (°)	Height (m)	Comments
PK	5.1498G	67.88	74.00	-6.12	7.27	3	Horizontal	344	1.01	-
AV	5.1496G	52.37	54.00	-1.63	7.27	3	Horizontal	344	1.01	-
PK	5.2056G	117.31	Inf	-Inf	7.36	3	Horizontal	344	1.01	-
AV	5.201G	107.85	Inf	-Inf	7.36	3	Horizontal	344	1.01	-

802.11a_Nss1,(6Mbps)_2TX

13/02/2019

5200MHz_TX

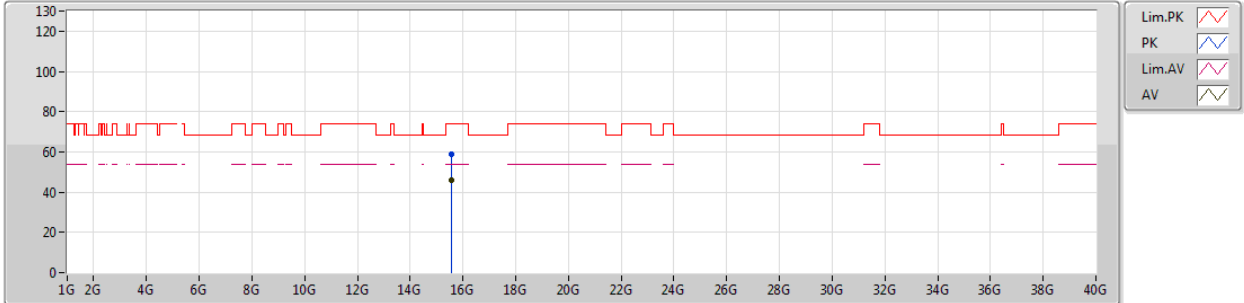

EUT_Z_2TX
Setting 21
03-E-2
FSP

Type	Freq	Level	Limit	Margin	Factor	Dist	Condition	Azimuth	Height	Comments
	(Hz)	(dBuV/m)	(dBuV/m)	(dB)	(dB)	(m)		(°)	(m)	
PK	15.58575G	59.11	74.00	-14.89	15.08	3	Vertical	110	1.18	-
AV	15.58605G	45.97	54.00	-8.03	15.08	3	Vertical	110	1.18	-

802.11a_Nss1,(6Mbps)_2TX

13/02/2019

5200MHz_TX

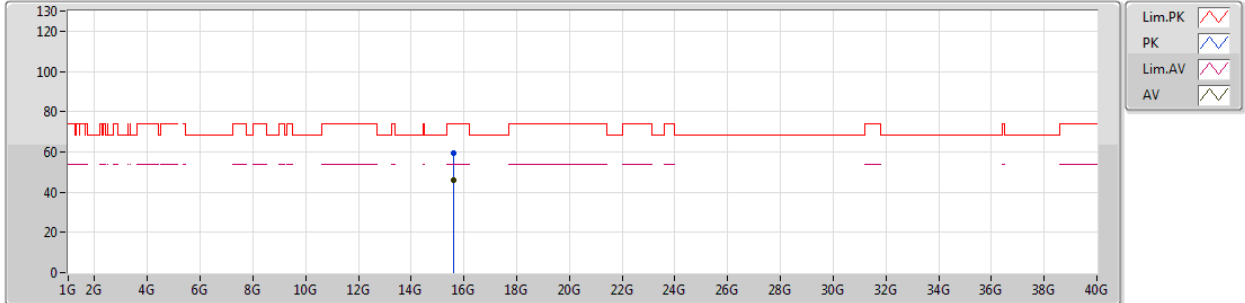

EUT_Z_2TX
Setting 21
03-E-2
FSP

Type	Freq (Hz)	Level (dBuV/m)	Limit (dBuV/m)	Margin (dB)	Factor (dB)	Dist (m)	Condition	Azimuth (°)	Height (m)	Comments
PK	15.58893G	59.13	74.00	-14.87	15.07	3	Horizontal	81	1.71	-
AV	15.60327G	45.95	54.00	-8.05	15.02	3	Horizontal	81	1.71	-

802.11a_Nss1,(6Mbps)_2TX

13/02/2019

5240MHz_TX

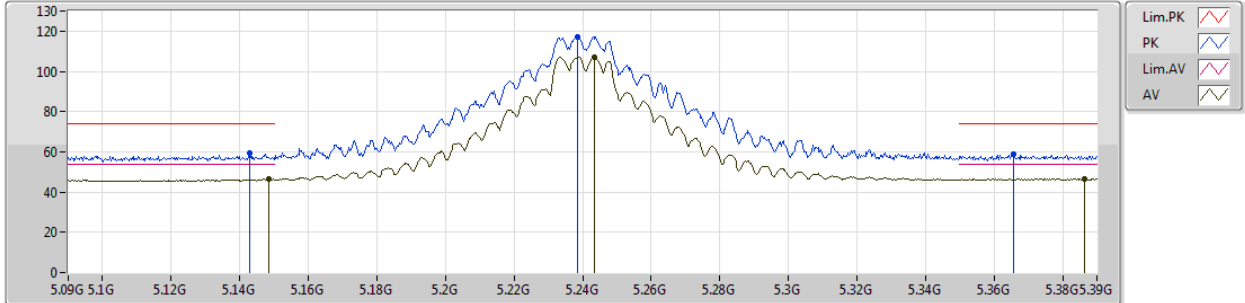

EUT_Z_2TX
Setting 25
03-E-2-10
FSP

Type	Freq (Hz)	Level (dBuV/m)	Limit (dBuV/m)	Margin (dB)	Factor (dB)	Dist (m)	Condition	Azimuth (°)	Height (m)	Comments
PK	5.1428G	59.25	74.00	-14.75	5.81	3	Vertical	233	2.76	-
AV	5.1485G	46.55	54.00	-7.45	5.83	3	Vertical	233	2.76	-
PK	5.2385G	117.35	Inf	-Inf	6.03	3	Vertical	233	2.76	-
AV	5.2433G	107.17	Inf	-Inf	6.05	3	Vertical	233	2.76	-
PK	5.3657G	58.74	74.00	-15.26	6.34	3	Vertical	233	2.76	-
AV	5.3864G	46.51	54.00	-7.49	6.38	3	Vertical	233	2.76	-

802.11a_Nss1,(6Mbps)_2TX

13/02/2019

5240MHz_TX

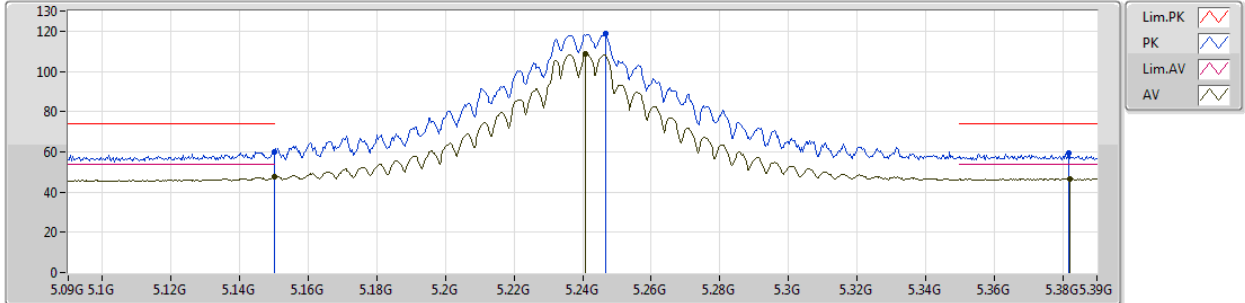

EUT_Z_2TX
Setting 25
03-E-2-10
FSP

Type	Freq (Hz)	Level (dBuV/m)	Limit (dBuV/m)	Margin (dB)	Factor (dB)	Dist (m)	Condition	Azimuth (°)	Height (m)	Comments
PK	5.15G	60.16	74.00	-13.84	5.83	3	Horizontal	349	1.01	-
AV	5.15G	47.44	54.00	-6.56	5.83	3	Horizontal	349	1.01	-
PK	5.2466G	118.53	Inf	-Inf	6.05	3	Horizontal	349	1.01	-
AV	5.2409G	108.62	Inf	-Inf	6.03	3	Horizontal	349	1.01	-
PK	5.3819G	59.16	74.00	-14.84	6.36	3	Horizontal	349	1.01	-
AV	5.3822G	46.53	54.00	-7.47	6.36	3	Horizontal	349	1.01	-

802.11a_Nss1,(6Mbps)_2TX

13/02/2019

5240MHz_TX

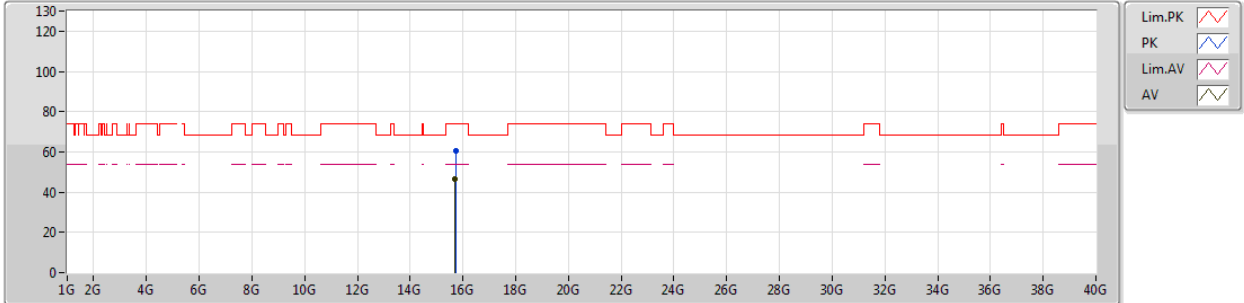

EUT_Z_2TX
Setting 25
03-E-2
FSP

Type	Freq (Hz)	Level (dBuV/m)	Limit (dBuV/m)	Margin (dB)	Factor (dB)	Dist (m)	Condition	Azimuth (°)	Height (m)	Comments
PK	15.71931G	60.53	74.00	-13.47	14.58	3	Vertical	105	1.50	-
AV	15.70809G	46.29	54.00	-7.71	14.63	3	Vertical	105	1.50	-

802.11a_Nss1,(6Mbps)_2TX

13/02/2019

5240MHz_TX

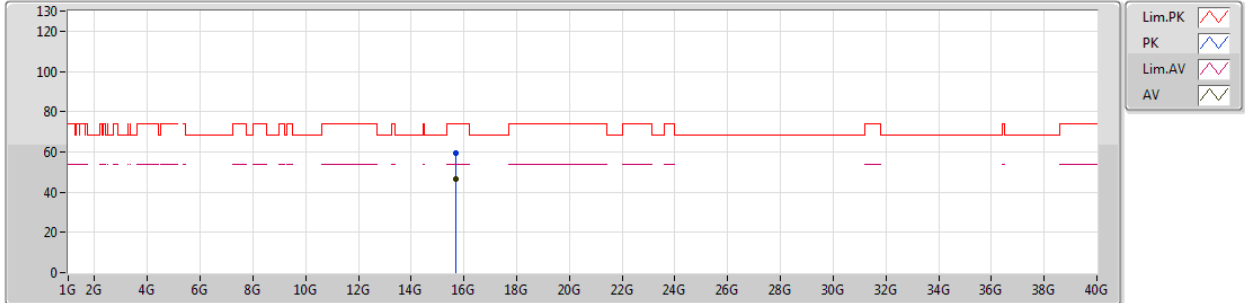

EUT_Z_2TX
Setting 25
03-E-2
FSP

Type	Freq (Hz)	Level (dBuV/m)	Limit (dBuV/m)	Margin (dB)	Factor (dB)	Dist (m)	Condition	Azimuth (°)	Height (m)	Comments
PK	15.70881G	59.25	74.00	-14.75	14.62	3	Horizontal	259	1.10	-
AV	15.71442G	46.26	54.00	-7.74	14.61	3	Horizontal	259	1.10	-

802.11a_Nss1,(6Mbps)_2TX

13/02/2019

5745MHz_TX

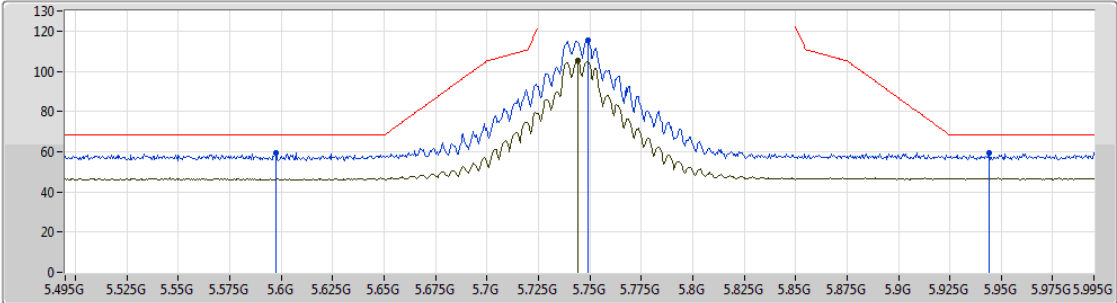

EUT_Z_2TX
Setting 25
03-E-2-10
FSP

Type	Freq (Hz)	Level (dBuV/m)	Limit (dBuV/m)	Margin (dB)	Factor (dB)	Dist (m)	Condition	Azimuth (°)	Height (m)	Comments
PK	5.5975G	59.29	68.20	-8.91	6.37	3	Vertical	227	2.58	-
PK	5.749G	115.46	Inf	-Inf	6.41	3	Vertical	227	2.58	-
AV	5.744G	105.27	Inf	-Inf	6.41	3	Vertical	227	2.58	-
PK	5.944G	59.25	68.20	-8.95	6.88	3	Vertical	227	2.58	-



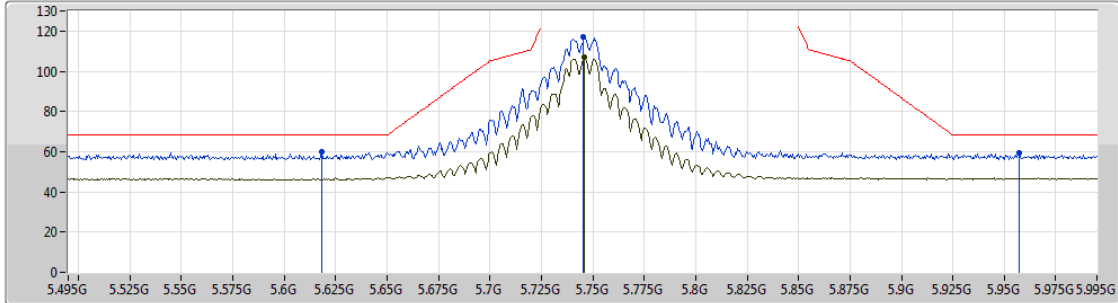

802.11a_Nss1,(6Mbps)_2TX

13/02/2019

5745MHz_TX



Legend for the spectrum plot:

- Lim.PK 
- PK 
- Lim.AV 
- AV 

EUT_Z_2TX
Setting 25
03-E-2-10
FSP

Type	Freq (Hz)	Level (dBuV/m)	Limit (dBuV/m)	Margin (dB)	Factor (dB)	Dist (m)	Condition	Azimuth (°)	Height (m)	Comments
PK	5.618G	59.83	68.20	-8.37	6.37	3	Horizontal	340	1.00	-
PK	5.7455G	117.20	Inf	-Inf	6.41	3	Horizontal	340	1.00	-
AV	5.746G	107.14	Inf	-Inf	6.41	3	Horizontal	340	1.00	-
PK	5.957G	59.20	68.20	-9.00	6.92	3	Horizontal	340	1.00	-

802.11a_Nss1,(6Mbps)_2TX

13/02/2019

5745MHz_TX

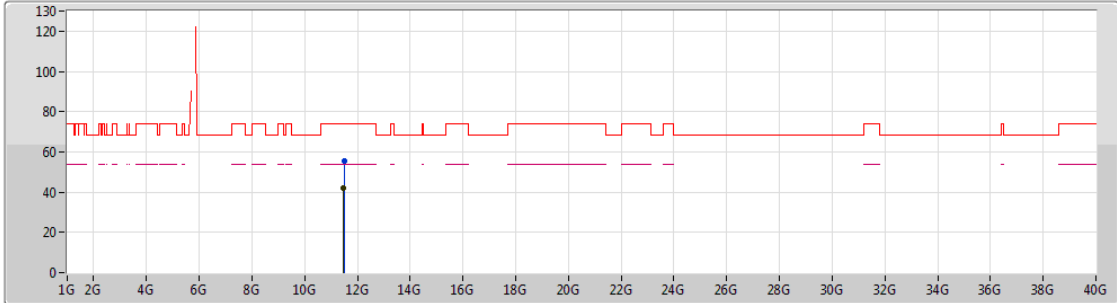

EUT_Z_2TX
Setting 25
03-E-2
FSP

Type	Freq (Hz)	Level (dBuV/m)	Limit (dBuV/m)	Margin (dB)	Factor (dB)	Dist (m)	Condition	Azimuth (°)	Height (m)	Comments
PK	11.49273G	55.48	74.00	-18.52	14.41	3	Vertical	48	1.41	-
AV	11.48415G	42.04	54.00	-11.96	14.41	3	Vertical	48	1.41	-

802.11a_Nss1,(6Mbps)_2TX

13/02/2019

5745MHz_TX

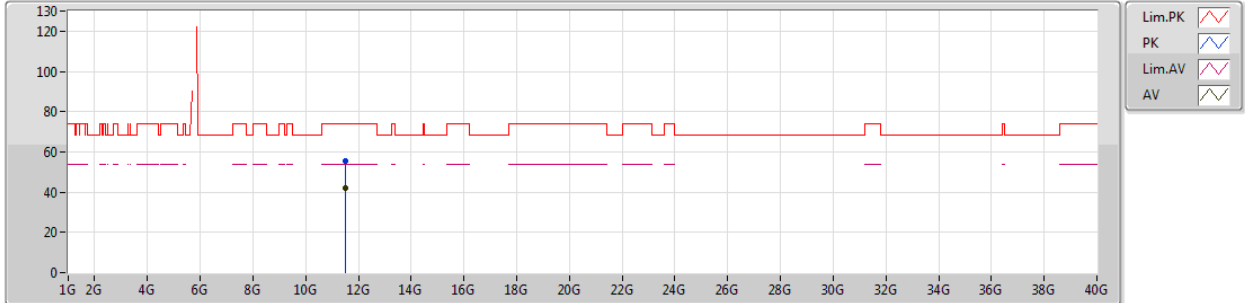

EUT_Z_2TX
Setting 25
03-E-2
FSP

Type	Freq (Hz)	Level (dBuV/m)	Limit (dBuV/m)	Margin (dB)	Factor (dB)	Dist (m)	Condition	Azimuth (°)	Height (m)	Comments
PK	11.49753G	55.52	74.00	-18.48	14.42	3	Horizontal	209	2.77	-
AV	11.49081G	42.16	54.00	-11.84	14.41	3	Horizontal	209	2.77	-

802.11a_Nss1,(6Mbps)_2TX

13/02/2019

5785MHz_TX

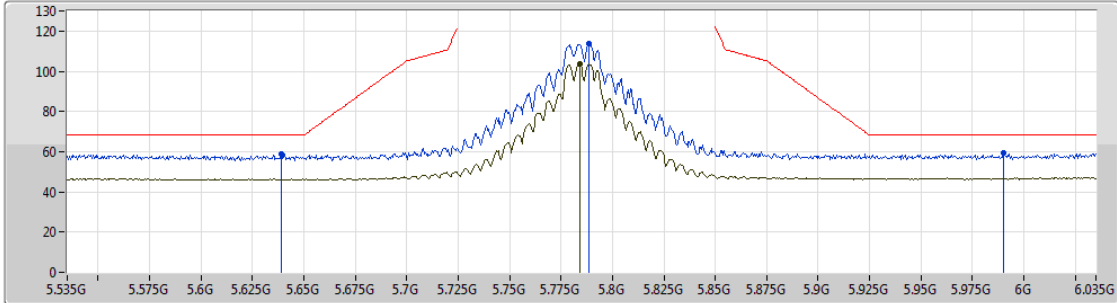

Lim.PK
 PK
 Lim.AV
 AV

EUT_Z_2TX
Setting 25
03-E-2-10
FSP

Type	Freq (Hz)	Level (dBuV/m)	Limit (dBuV/m)	Margin (dB)	Factor (dB)	Dist (m)	Condition	Azimuth (°)	Height (m)	Comments
PK	5.639G	58.99	68.20	-9.21	6.37	3	Vertical	228	2.56	-
PK	5.7885G	113.80	Inf	-Inf	6.45	3	Vertical	228	2.56	-
AV	5.784G	103.54	Inf	-Inf	6.44	3	Vertical	228	2.56	-
PK	5.99G	59.37	68.20	-8.83	7.04	3	Vertical	228	2.56	-

802.11a_Nss1,(6Mbps)_2TX

13/02/2019

5785MHz_TX

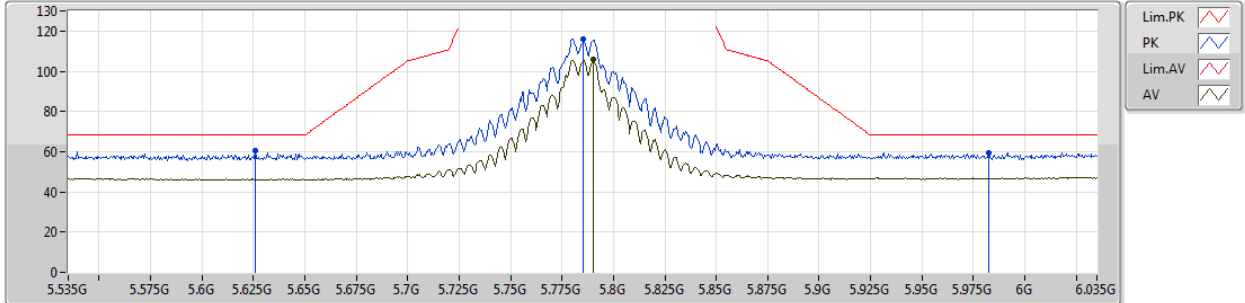

EUT_Z_2TX
Setting 25
03-E-2-10
FSP

Type	Freq (Hz)	Level (dBuV/m)	Limit (dBuV/m)	Margin (dB)	Factor (dB)	Dist (m)	Condition	Azimuth (°)	Height (m)	Comments
PK	5.626G	60.57	68.20	-7.63	6.37	3	Horizontal	333	1.00	-
PK	5.7855G	115.80	Inf	-Inf	6.44	3	Horizontal	333	1.00	-
AV	5.79G	105.86	Inf	-Inf	6.45	3	Horizontal	333	1.00	-
PK	5.9825G	59.16	68.20	-9.04	7.02	3	Horizontal	333	1.00	-

802.11a_Nss1,(6Mbps)_2TX

13/02/2019

5785MHz_TX

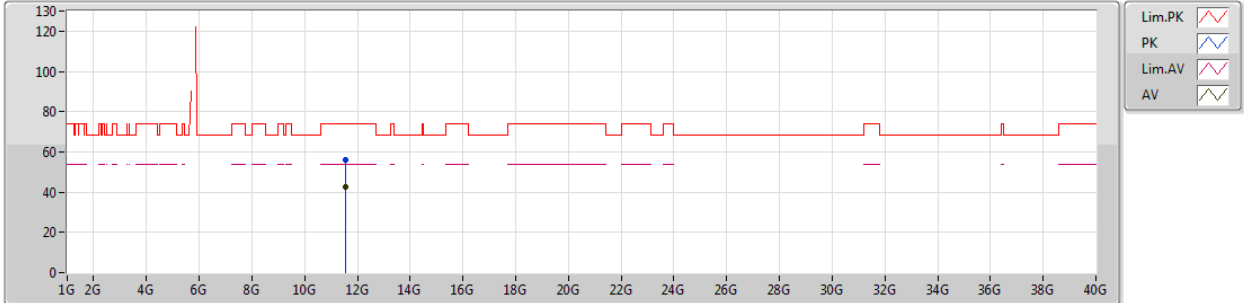

EUT_Z_2TX
Setting 25
03-E-2
FSP

Type	Freq (Hz)	Level (dBuV/m)	Limit (dBuV/m)	Margin (dB)	Factor (dB)	Dist (m)	Condition	Azimuth (°)	Height (m)	Comments
PK	11.56382G	56.05	74.00	-17.95	14.48	3	Vertical	205	1.15	-
AV	11.57153G	42.69	54.00	-11.31	14.50	3	Vertical	205	1.15	-

802.11a_Nss1,(6Mbps)_2TX

13/02/2019

5785MHz_TX

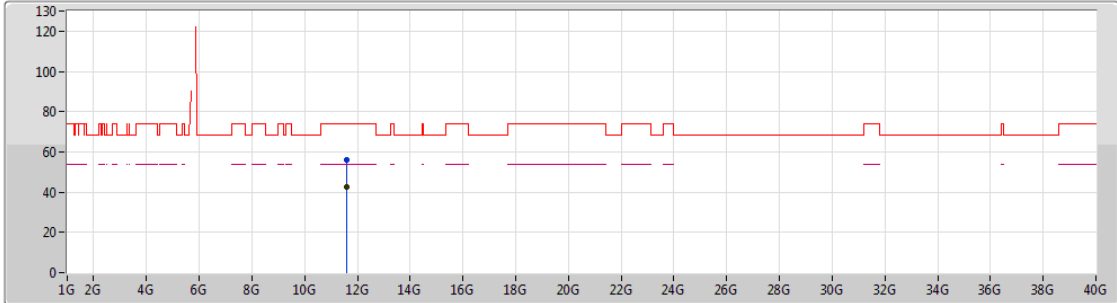

Lim.PK
 PK
 Lim.AV
 AV

EUT_Z_2TX
Setting 25
03-E-2
FSP

Type	Freq (Hz)	Level (dBuV/m)	Limit (dBuV/m)	Margin (dB)	Factor (dB)	Dist (m)	Condition	Azimuth (°)	Height (m)	Comments
PK	11.57441G	56.22	74.00	-17.78	14.50	3	Horizontal	239	1.11	-
AV	11.57594G	42.51	54.00	-11.49	14.50	3	Horizontal	239	1.11	-

802.11a_Nss1,(6Mbps)_2TX

13/02/2019

5825MHz_TX

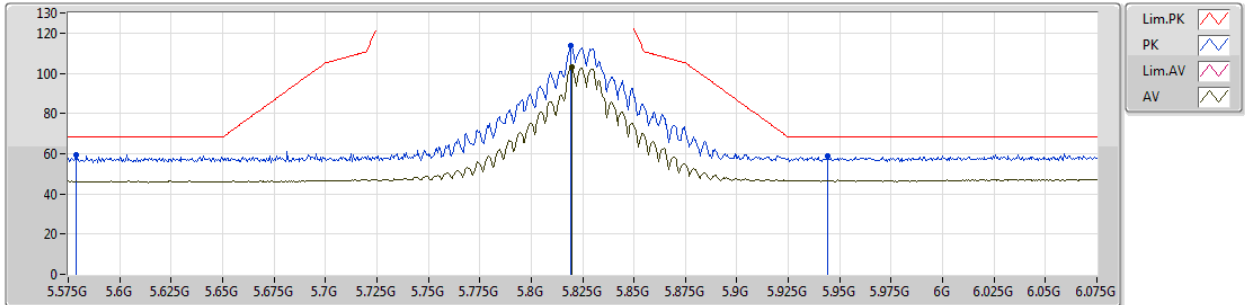

EUT_Z_2TX
Setting 25
03-E-2-10
FSP

Type	Freq (Hz)	Level (dBuV/m)	Limit (dBuV/m)	Margin (dB)	Factor (dB)	Dist (m)	Condition	Azimuth (°)	Height (m)	Comments
PK	5.579G	59.38	68.20	-8.82	6.39	3	Vertical	218	2.55	-
PK	5.8195G	113.73	Inf	-Inf	6.51	3	Vertical	218	2.55	-
AV	5.82G	102.99	Inf	-Inf	6.51	3	Vertical	218	2.55	-
PK	5.944G	58.95	68.20	-9.25	6.88	3	Vertical	218	2.55	-

802.11a_Nss1,(6Mbps)_2TX

13/02/2019

5825MHz_TX

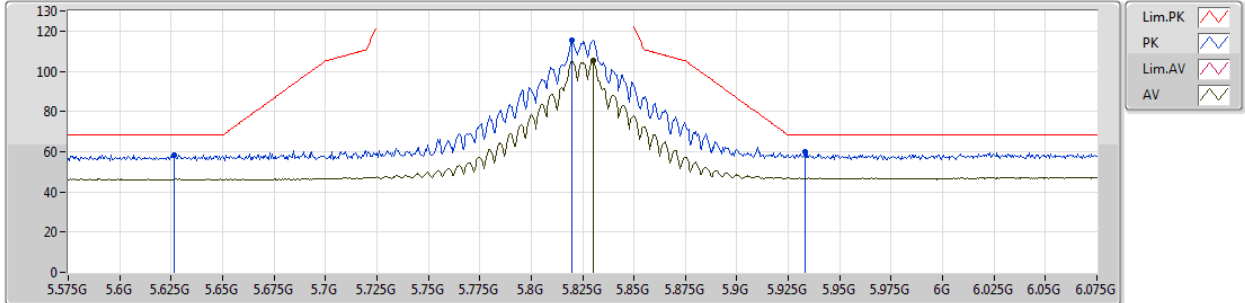

EUT_Z_2TX
Setting 25
03-E-2-10
FSP

Type	Freq (Hz)	Level (dBuV/m)	Limit (dBuV/m)	Margin (dB)	Factor (dB)	Dist (m)	Condition	Azimuth (°)	Height (m)	Comments
PK	5.6265G	58.55	68.20	-9.65	6.37	3	Horizontal	329	1.05	-
PK	5.82G	115.58	Inf	-Inf	6.51	3	Horizontal	329	1.05	-
AV	5.83G	105.46	Inf	-Inf	6.54	3	Horizontal	329	1.05	-
PK	5.933G	59.90	68.20	-8.30	6.84	3	Horizontal	329	1.05	-

802.11a_Nss1,(6Mbps)_2TX

13/02/2019

5825MHz_TX

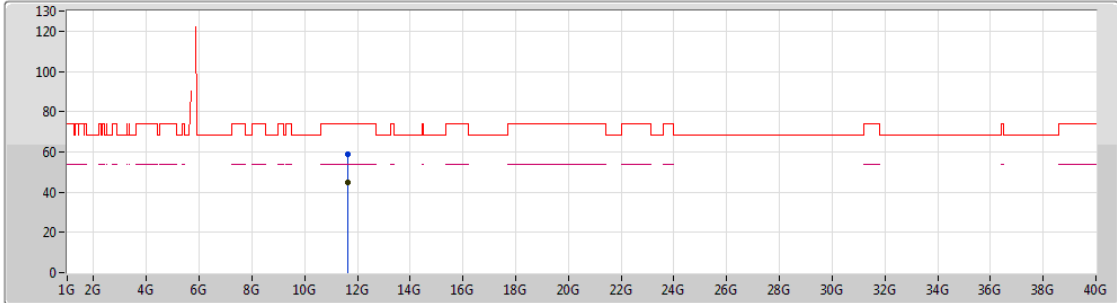

Lim.PK
 PK
 Lim.AV
 AV

EUT_Z_2TX
Setting 25
03-E-2
FSP

Type	Freq (Hz)	Level (dBuV/m)	Limit (dBuV/m)	Margin (dB)	Factor (dB)	Dist (m)	Condition	Azimuth (°)	Height (m)	Comments
PK	11.65108G	58.69	74.00	-15.31	14.58	3	Vertical	222	1.40	-
AV	11.64988G	44.56	54.00	-9.44	14.57	3	Vertical	222	1.40	-

802.11a_Nss1,(6Mbps)_2TX

13/02/2019

5825MHz_TX

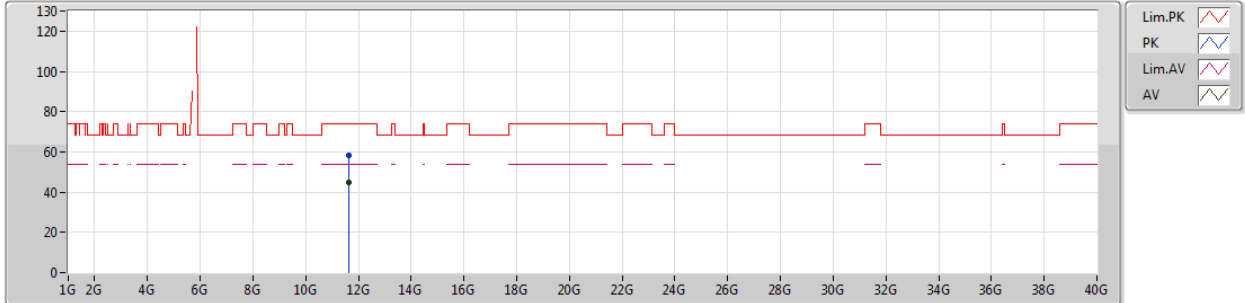

EUT_Z_2TX
Setting 25
03-E-2
FSP

Type	Freq (Hz)	Level (dBuV/m)	Limit (dBuV/m)	Margin (dB)	Factor (dB)	Dist (m)	Condition	Azimuth (°)	Height (m)	Comments
PK	11.65138G	58.28	74.00	-15.72	14.58	3	Horizontal	120	2.09	-
AV	11.65012G	44.76	54.00	-9.24	14.58	3	Horizontal	120	2.09	-

802.11ac VHT20_Nss1,(MCS0)_2TX

25/02/2019

5180MHz_TX

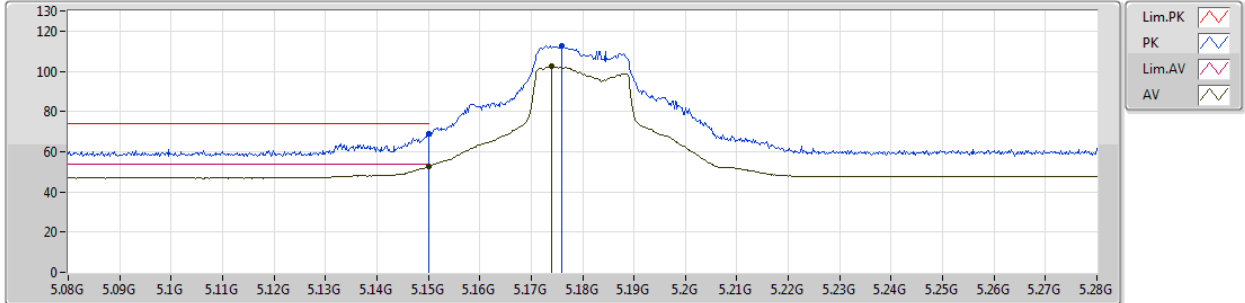

EUT_Z_2TX
Setting 16.5
06-K-3-10
FSP

Type	Freq (Hz)	Level (dBuV/m)	Limit (dBuV/m)	Margin (dB)	Factor (dB)	Dist (m)	Condition	Azimuth (°)	Height (m)	Comments
PK	5.15G	68.86	74.00	-5.14	7.27	3	Vertical	226	2.95	-
AV	5.15G	52.69	54.00	-1.31	7.27	3	Vertical	226	2.95	-
PK	5.176G	112.70	Inf	-Inf	7.33	3	Vertical	226	2.95	-
AV	5.174G	102.33	Inf	-Inf	7.32	3	Vertical	226	2.95	-

802.11ac VHT20_Nss1,(MCS0)_2TX

25/02/2019

5180MHz_TX

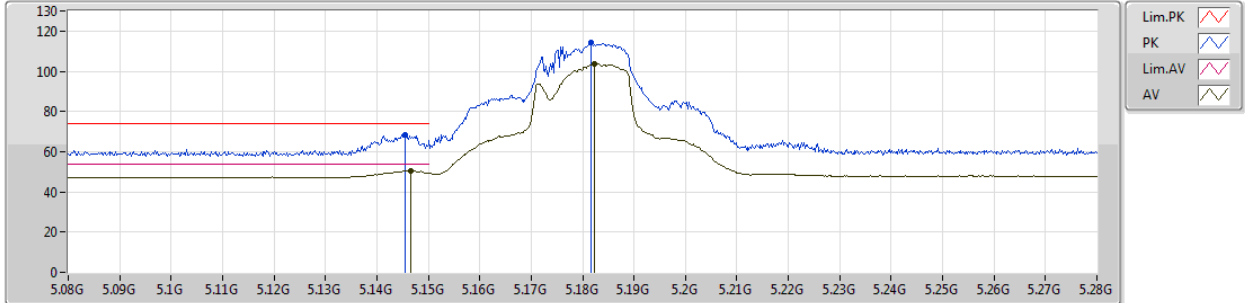

EUT_Z_2TX
Setting 16.5
06-K-3-10
FSP

Type	Freq (Hz)	Level (dBuV/m)	Limit (dBuV/m)	Margin (dB)	Factor (dB)	Dist (m)	Condition	Azimuth (°)	Height (m)	Comments
PK	5.1456G	68.22	74.00	-5.78	7.27	3	Horizontal	344	1.01	-
AV	5.1466G	50.51	54.00	-3.49	7.27	3	Horizontal	344	1.01	-
PK	5.1816G	114.09	Inf	-Inf	7.33	3	Horizontal	344	1.01	-
AV	5.1824G	103.48	Inf	-Inf	7.33	3	Horizontal	344	1.01	-

802.11ac VHT20_Nss1,(MCS0)_2TX

13/02/2019

5180MHz_TX

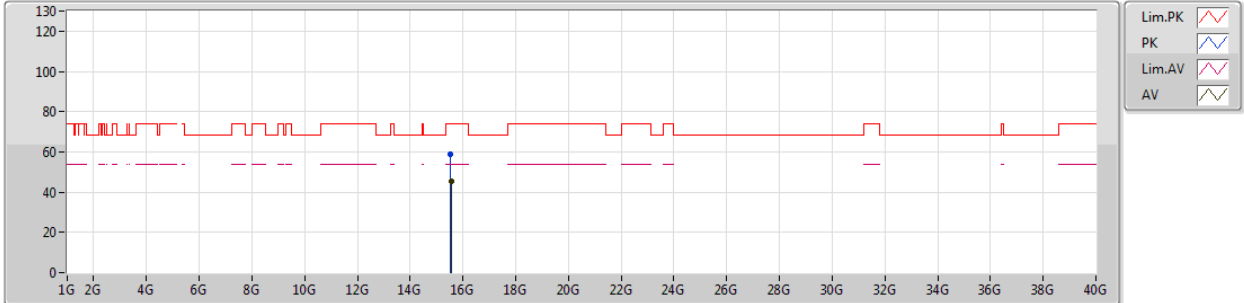

EUT_Z_2TX
Setting 17
03-E-2
FSP

Type	Freq (Hz)	Level (dBuV/m)	Limit (dBuV/m)	Margin (dB)	Factor (dB)	Dist (m)	Condition	Azimuth (°)	Height (m)	Comments
PK	15.5331G	58.72	74.00	-15.28	15.29	3	Vertical	255	1.93	-
AV	15.55176G	45.44	54.00	-8.56	15.21	3	Vertical	255	1.93	-

802.11ac VHT20_Nss1,(MCS0)_2TX

13/02/2019

5180MHz_TX

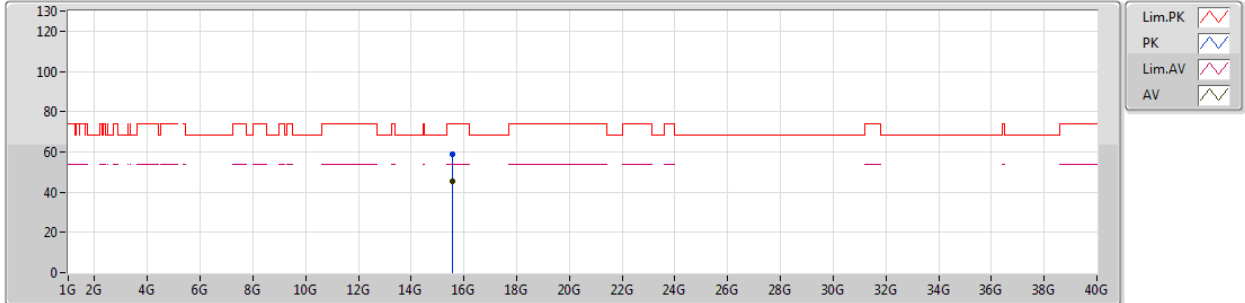

EUT_Z_2TX
Setting 17
03-E-2
FSP

Type	Freq	Level	Limit	Margin	Factor	Dist	Condition	Azimuth	Height	Comments
	(Hz)	(dBuV/m)	(dBuV/m)	(dB)	(dB)	(m)		(°)	(m)	
PK	15.55293G	59.03	74.00	-14.97	15.21	3	Horizontal	208	1.58	-
AV	15.55293G	45.61	54.00	-8.39	15.21	3	Horizontal	208	1.58	-

802.11ac VHT20_Nss1,(MCS0)_2TX

25/02/2019

5200MHz_TX

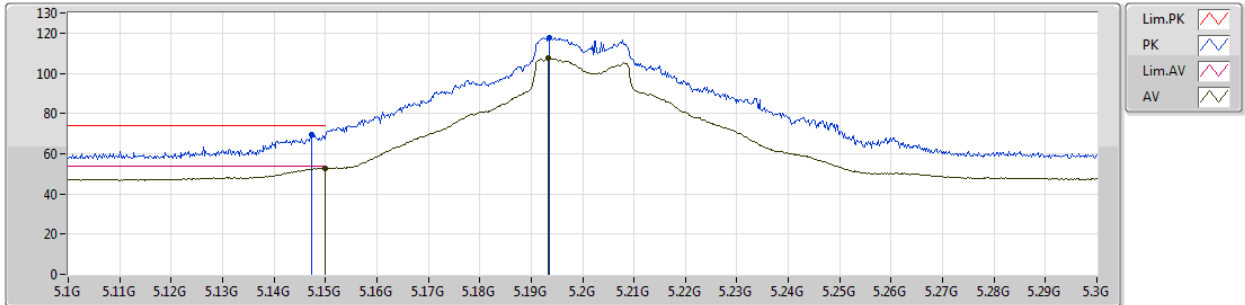

EUT_Z_2TX
Setting 21
06-K-3-10
FSP

Type	Freq (Hz)	Level (dBuV/m)	Limit (dBuV/m)	Margin (dB)	Factor (dB)	Dist (m)	Condition	Azimuth (°)	Height (m)	Comments
PK	5.1474G	69.31	74.00	-4.69	7.27	3	Vertical	237	2.91	-
AV	5.15G	52.78	54.00	-1.22	7.27	3	Vertical	237	2.91	-
PK	5.1936G	117.58	Inf	-Inf	7.35	3	Vertical	237	2.91	-
AV	5.1934G	107.34	Inf	-Inf	7.35	3	Vertical	237	2.91	-

802.11ac VHT20_Nss1,(MCS0)_2TX

25/02/2019

5200MHz_TX

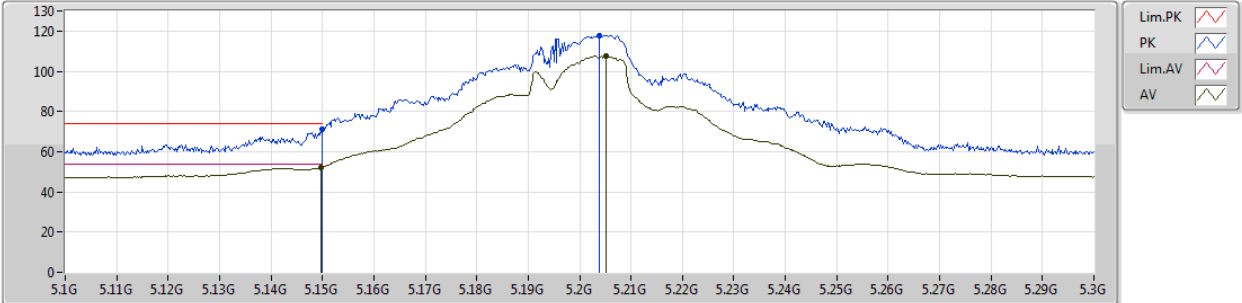

EUT_Z_2TX
Setting 21
06-K-3-10
FSP

Type	Freq (Hz)	Level (dBuV/m)	Limit (dBuV/m)	Margin (dB)	Factor (dB)	Dist (m)	Condition	Azimuth (°)	Height (m)	Comments
PK	5.15G	71.04	74.00	-2.96	7.27	3	Horizontal	346	1.00	-
AV	5.1498G	52.38	54.00	-1.62	7.27	3	Horizontal	346	1.00	-
PK	5.2038G	117.84	Inf	-Inf	7.36	3	Horizontal	346	1.00	-
AV	5.2052G	107.54	Inf	-Inf	7.36	3	Horizontal	346	1.00	-

802.11ac VHT20_Nss1,(MCS0)_2TX

13/02/2019

5200MHz_TX

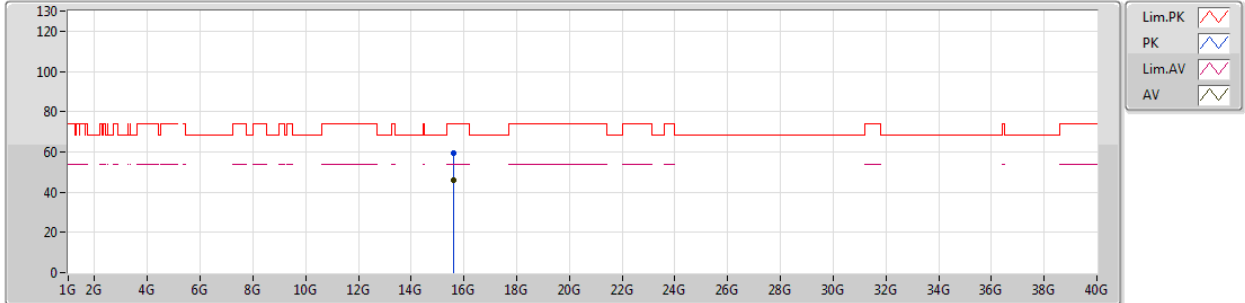

EUT_Z_2TX
Setting 21.5
03-E-2
FSP

Type	Freq (Hz)	Level (dBuV/m)	Limit (dBuV/m)	Margin (dB)	Factor (dB)	Dist (m)	Condition	Azimuth (°)	Height (m)	Comments
PK	15.59877G	59.13	74.00	-14.87	15.03	3	Vertical	205	1.93	-
AV	15.61026G	45.67	54.00	-8.33	14.99	3	Vertical	205	1.93	-

802.11ac VHT20_Nss1,(MCS0)_2TX

13/02/2019

5200MHz_TX

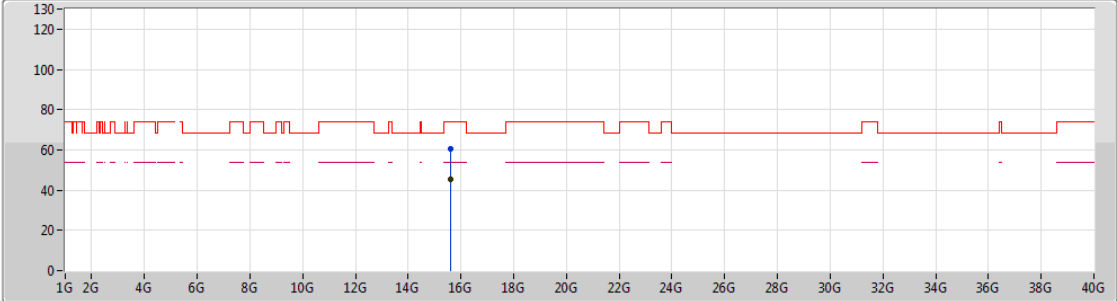

Lim.PK
 PK
 Lim.AV
 AV

EUT_Z_2TX
 Setting 21.5
 03-E-2
 FSP

Type	Freq	Level	Limit	Margin	Factor	Dist	Condition	Azimuth	Height	Comments
	(Hz)	(dBuV/m)	(dBuV/m)	(dB)	(dB)	(m)		(°)	(m)	
PK	15.58929G	60.47	74.00	-13.53	15.07	3	Horizontal	110	2.28	-
AV	15.61473G	45.64	54.00	-8.36	14.99	3	Horizontal	110	2.28	-

802.11ac VHT20_Nss1,(MCS0)_2TX

13/02/2019

5240MHz_TX

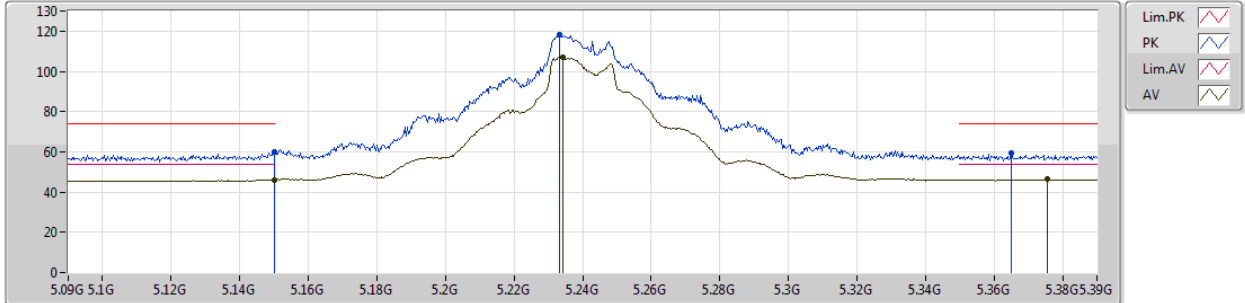

EUT_Z_2TX
Setting 25
03-E-2-10
FSP

Type	Freq (Hz)	Level (dBuV/m)	Limit (dBuV/m)	Margin (dB)	Factor (dB)	Dist (m)	Condition	Azimuth (°)	Height (m)	Comments
PK	5.15G	59.98	74.00	-14.02	5.83	3	Vertical	236	2.75	-
AV	5.15G	46.17	54.00	-7.83	5.83	3	Vertical	236	2.75	-
PK	5.231G	118.05	Inf	-Inf	6.02	3	Vertical	236	2.75	-
AV	5.2343G	107.21	Inf	-Inf	6.02	3	Vertical	236	2.75	-
PK	5.3651G	59.33	74.00	-14.67	6.34	3	Vertical	236	2.75	-
AV	5.3756G	46.23	54.00	-7.77	6.36	3	Vertical	236	2.75	-

802.11ac VHT20_Nss1,(MCS0)_2TX

13/02/2019

5240MHz_TX

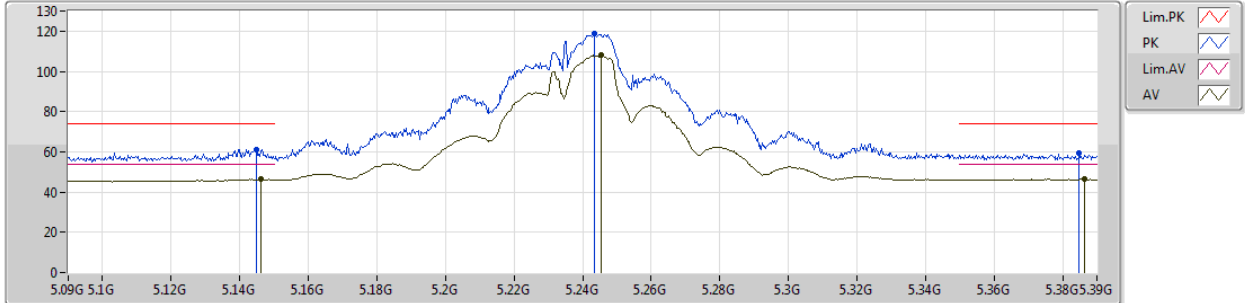

EUT_Z_2TX
Setting 25
03-E-2-10
FSP

Type	Freq (Hz)	Level (dBuV/m)	Limit (dBuV/m)	Margin (dB)	Factor (dB)	Dist (m)	Condition	Azimuth (°)	Height (m)	Comments
PK	5.1449G	61.29	74.00	-12.71	5.82	3	Horizontal	347	1.00	-
AV	5.1461G	46.30	54.00	-7.70	5.83	3	Horizontal	347	1.00	-
PK	5.2436G	118.59	Inf	-Inf	6.05	3	Horizontal	347	1.00	-
AV	5.2454G	108.01	Inf	-Inf	6.05	3	Horizontal	347	1.00	-
PK	5.3849G	59.18	74.00	-14.82	6.37	3	Horizontal	347	1.00	-
AV	5.3864G	46.44	54.00	-7.56	6.38	3	Horizontal	347	1.00	-

802.11ac VHT20_Nss1,(MCS0)_2TX

13/02/2019

5240MHz_TX

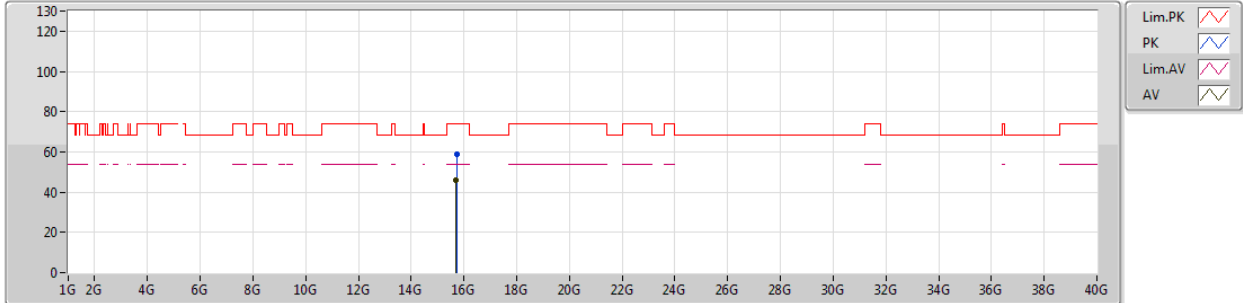

EUT_Z_2TX
Setting 25
03-E-2
FSP

Type	Freq (Hz)	Level (dBuV/m)	Limit (dBuV/m)	Margin (dB)	Factor (dB)	Dist (m)	Condition	Azimuth (°)	Height (m)	Comments
PK	15.72504G	59.10	74.00	-14.90	14.55	3	Vertical	241	2.27	-
AV	15.71439G	45.70	54.00	-8.30	14.61	3	Vertical	241	2.27	-

802.11ac VHT20_Nss1,(MCS0)_2TX

13/02/2019

5240MHz_TX

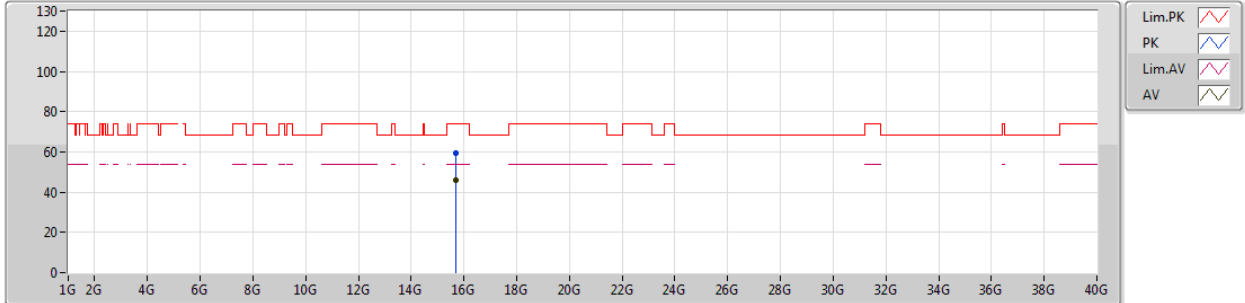

EUT_Z_2TX
Setting 25
03-E-2
FSP

Type	Freq (Hz)	Level (dBuV/m)	Limit (dBuV/m)	Margin (dB)	Factor (dB)	Dist (m)	Condition	Azimuth (°)	Height (m)	Comments
PK	15.70518G	59.46	74.00	-14.54	14.63	3	Horizontal	316	1.50	-
AV	15.705G	45.80	54.00	-8.20	14.65	3	Horizontal	316	1.50	-

802.11ac VHT20_Nss1,(MCS0)_2TX

13/02/2019

5745MHz_TX

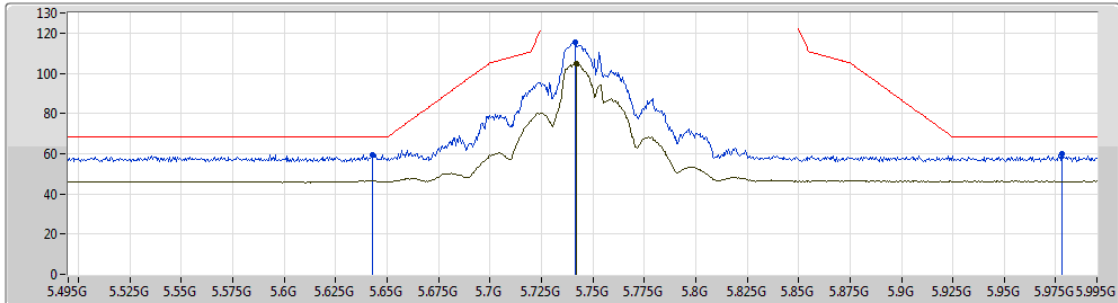

Legend for the spectrum plot:

- Lim.PK (Red line with downward triangle)
- PK (Blue line with upward triangle)
- Lim.AV (Red line with downward triangle)
- AV (Blue line with upward triangle)

EUT_Z_2TX
Setting 25
03-E-2-10
FSP

Type	Freq (Hz)	Level (dBuV/m)	Limit (dBuV/m)	Margin (dB)	Factor (dB)	Dist (m)	Condition	Azimuth (°)	Height (m)	Comments
PK	5.643G	59.62	68.20	-8.58	6.38	3	Vertical	223	2.56	-
PK	5.7415G	115.67	Inf	-Inf	6.41	3	Vertical	223	2.56	-
AV	5.742G	104.57	Inf	-Inf	6.41	3	Vertical	223	2.56	-
PK	5.978G	60.15	68.20	-8.05	6.99	3	Vertical	223	2.56	-

802.11ac VHT20_Nss1,(MCS0)_2TX

13/02/2019

5745MHz_TX

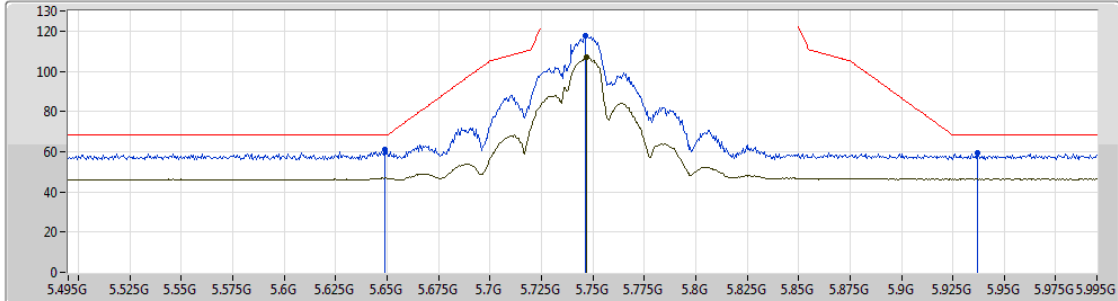

Lim.PK
 PK
 Lim.AV
 AV

EUT_Z_2TX
Setting 25
03-E-2-10
FSP

Type	Freq (Hz)	Level (dBuV/m)	Limit (dBuV/m)	Margin (dB)	Factor (dB)	Dist (m)	Condition	Azimuth (°)	Height (m)	Comments
PK	5.649G	60.92	68.20	-7.28	6.37	3	Horizontal	338	1.01	-
PK	5.7465G	117.65	Inf	-Inf	6.41	3	Horizontal	338	1.01	-
AV	5.747G	106.76	Inf	-Inf	6.41	3	Horizontal	338	1.01	-
PK	5.937G	59.63	68.20	-8.57	6.86	3	Horizontal	338	1.01	-

802.11ac VHT20_Nss1,(MCS0)_2TX

13/02/2019

5745MHz_TX

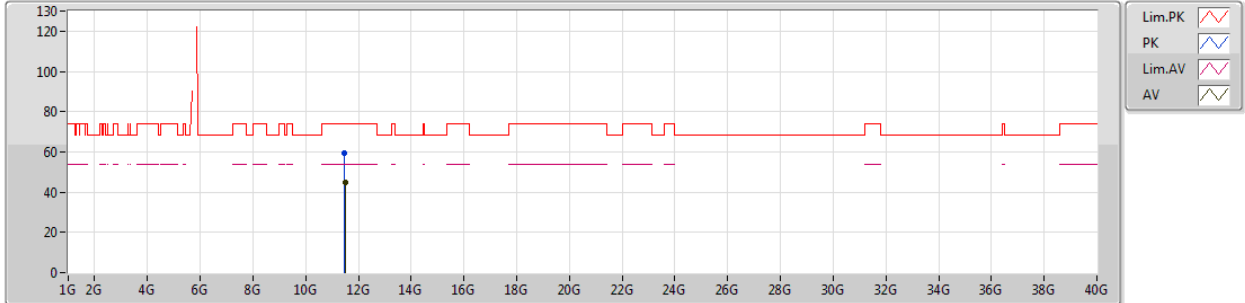

EUT_Z_2TX
Setting 25
03-E-2
FSP

Type	Freq (Hz)	Level (dBuV/m)	Limit (dBuV/m)	Margin (dB)	Factor (dB)	Dist (m)	Condition	Azimuth (°)	Height (m)	Comments
PK	11.48394G	59.42	74.00	-14.58	14.41	3	Vertical	188	2.08	-
AV	11.48976G	45.03	54.00	-8.97	14.41	3	Vertical	188	2.08	-

802.11ac VHT20_Nss1,(MCS0)_2TX

13/02/2019

5745MHz_TX

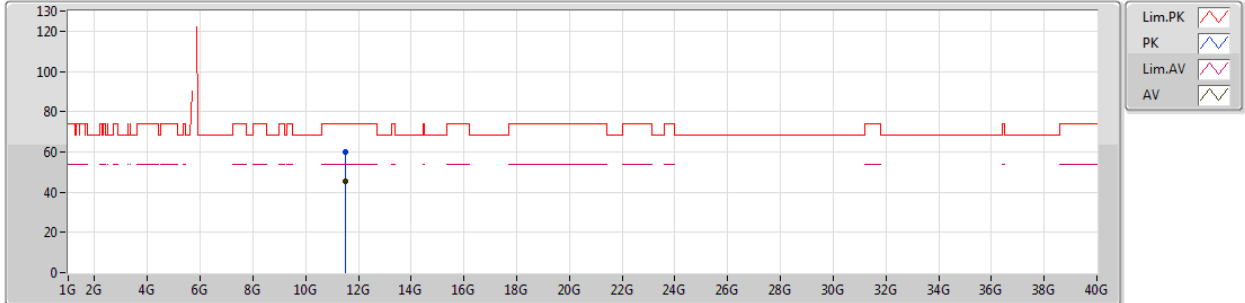

EUT_Z_2TX
Setting 25
03-E-2
FSP

Type	Freq (Hz)	Level (dBuV/m)	Limit (dBuV/m)	Margin (dB)	Factor (dB)	Dist (m)	Condition	Azimuth (°)	Height (m)	Comments
PK	11.49183G	59.70	74.00	-14.30	14.41	3	Horizontal	94	1.30	-
AV	11.49003G	45.21	54.00	-8.79	14.41	3	Horizontal	94	1.30	-

802.11ac VHT20_Nss1,(MCS0)_2TX

13/02/2019

5785MHz_TX

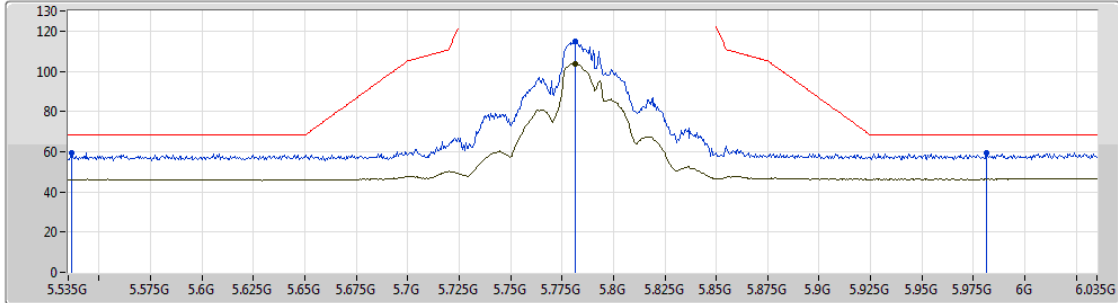

- Lim.PK
- PK
- Lim.AV
- AV

EUT_Z_2TX
Setting 25
03-E-2-10
FSP

Type	Freq (Hz)	Level (dBuV/m)	Limit (dBuV/m)	Margin (dB)	Factor (dB)	Dist (m)	Condition	Azimuth (°)	Height (m)	Comments
PK	5.5365G	59.47	68.20	-8.73	6.45	3	Vertical	226	2.55	-
PK	5.7815G	115.14	Inf	-Inf	6.44	3	Vertical	226	2.55	-
AV	5.7815G	103.83	Inf	-Inf	6.44	3	Vertical	226	2.55	-
PK	5.9815G	59.52	68.20	-8.68	7.01	3	Vertical	226	2.55	-

802.11ac VHT20_Nss1,(MCS0)_2TX

13/02/2019

5785MHz_TX

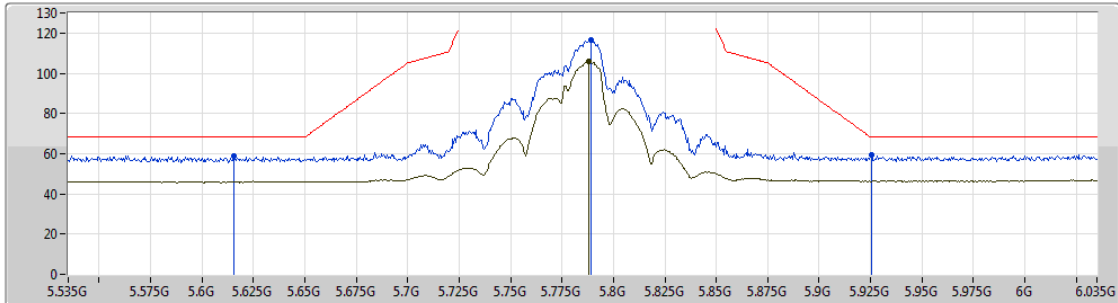

Lim.PK
 PK
 Lim.AV
 AV

EUT_Z_2TX
Setting 25
03-E-2-10
FSP

Type	Freq (Hz)	Level (dBuV/m)	Limit (dBuV/m)	Margin (dB)	Factor (dB)	Dist (m)	Condition	Azimuth (°)	Height (m)	Comments
PK	5.6155G	59.11	68.20	-9.09	6.37	3	Horizontal	338	1.00	-
PK	5.789G	116.61	Inf	-Inf	6.45	3	Horizontal	338	1.00	-
AV	5.788G	105.81	Inf	-Inf	6.45	3	Horizontal	338	1.00	-
PK	5.9255G	59.39	68.20	-8.81	6.82	3	Horizontal	338	1.00	-

802.11ac VHT20_Nss1,(MCS0)_2TX

13/02/2019

5785MHz_TX

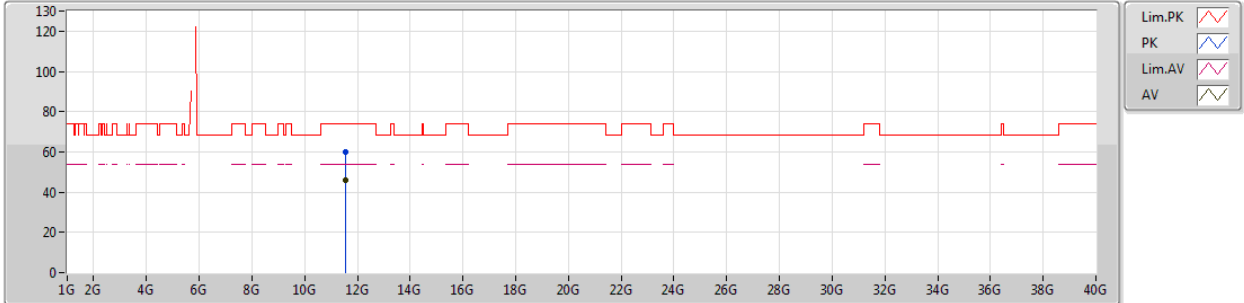

EUT_Z_2TX
Setting 25
03-E-2
FSP

Type	Freq (Hz)	Level (dBuV/m)	Limit (dBuV/m)	Margin (dB)	Factor (dB)	Dist (m)	Condition	Azimuth (°)	Height (m)	Comments
PK	11.56895G	59.88	74.00	-14.12	14.49	3	Vertical	79	2.10	-
AV	11.56985G	46.14	54.00	-7.86	14.50	3	Vertical	79	2.10	-

802.11ac VHT20_Nss1,(MCS0)_2TX

13/02/2019

5785MHz_TX

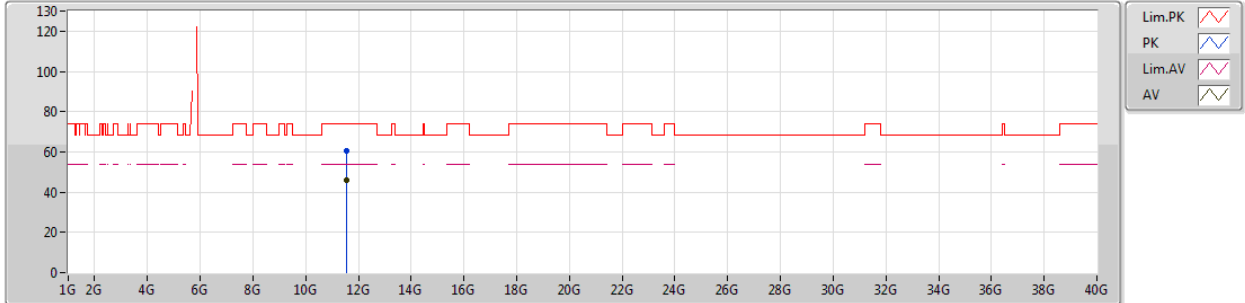

EUT_Z_2TX
Setting 25
03-E-2
FSP





Type	Freq (Hz)	Level (dBuV/m)	Limit (dBuV/m)	Margin (dB)	Factor (dB)	Dist (m)	Condition	Azimuth (°)	Height (m)	Comments
PK	11.57087G	60.28	74.00	-13.72	14.50	3	Horizontal	275	1.35	-
AV	11.57003G	46.06	54.00	-7.94	14.50	3	Horizontal	275	1.35	-

802.11ac VHT20_Nss1,(MCS0)_2TX

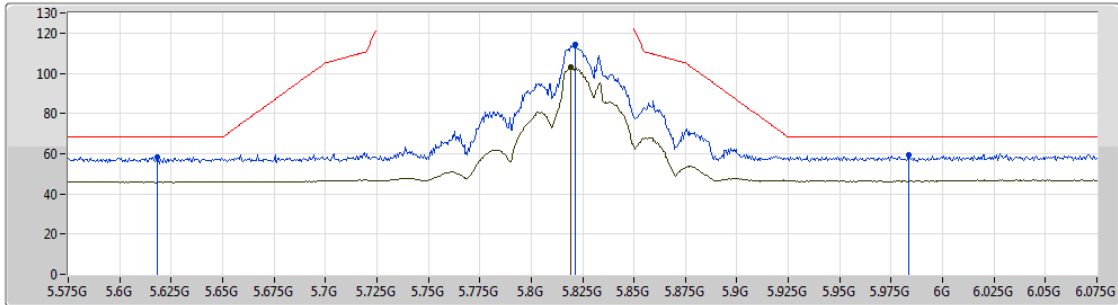
13/02/2019

5825MHz_TX



Lim.PK 
 PK 
 Lim.AV 
 AV 

EUT Z_2TX
Setting 25
03-E-2-10
FSP

Type	Freq (Hz)	Level (dBuV/m)	Limit (dBuV/m)	Margin (dB)	Factor (dB)	Dist (m)	Condition	Azimuth (°)	Height (m)	Comments
PK	5.618G	58.39	68.20	-9.81	6.37	3	Vertical	229	2.78	-
PK	5.8215G	114.37	Inf	-Inf	6.52	3	Vertical	229	2.78	-
AV	5.8195G	102.89	Inf	-Inf	6.51	3	Vertical	229	2.78	-
PK	5.9835G	59.16	68.20	-9.04	7.02	3	Vertical	229	2.78	-

802.11ac VHT20_Nss1,(MCS0)_2TX

13/02/2019

5825MHz_TX

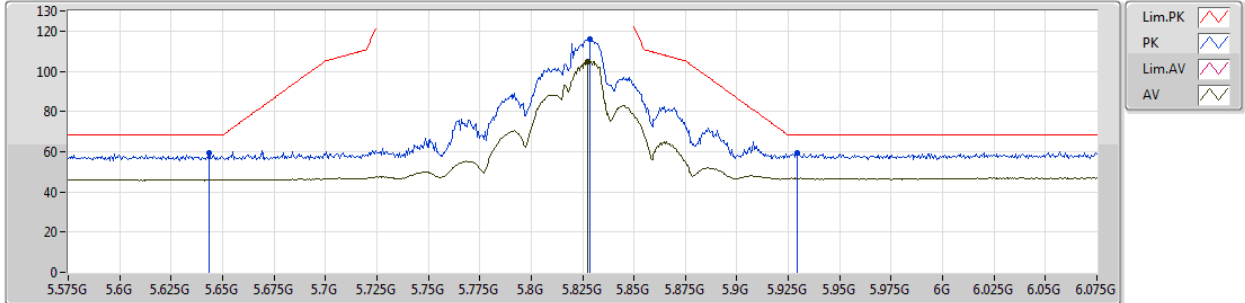

EUT_Z_2TX
Setting 25
03-E-2-10
FSP

Type	Freq (Hz)	Level (dBuV/m)	Limit (dBuV/m)	Margin (dB)	Factor (dB)	Dist (m)	Condition	Azimuth (°)	Height (m)	Comments
PK	5.6435G	59.21	68.20	-8.99	6.38	3	Horizontal	337	1.06	-
PK	5.8285G	116.09	Inf	-Inf	6.54	3	Horizontal	337	1.06	-
AV	5.8275G	105.00	Inf	-Inf	6.53	3	Horizontal	337	1.06	-
PK	5.9295G	59.57	68.20	-8.63	6.83	3	Horizontal	337	1.06	-

802.11ac VHT20_Nss1,(MCS0)_2TX

13/02/2019

5825MHz_TX

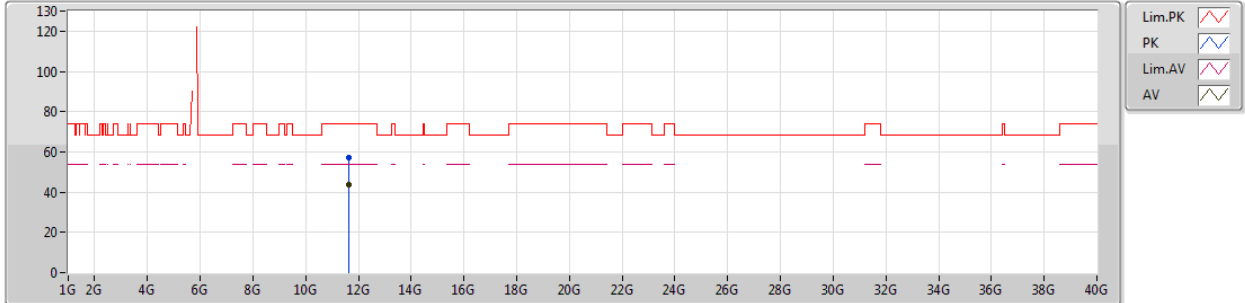

EUT_Z_2TX
Setting 25
03-E-2
FSP

Type	Freq (Hz)	Level (dBuV/m)	Limit (dBuV/m)	Margin (dB)	Factor (dB)	Dist (m)	Condition	Azimuth (°)	Height (m)	Comments
PK	11.64844G	57.24	74.00	-16.76	14.57	3	Vertical	123	1.81	-
AV	11.64853G	43.68	54.00	-10.32	14.57	3	Vertical	123	1.81	-

802.11ac VHT20_Nss1,(MCS0)_2TX

13/02/2019

5825MHz_TX

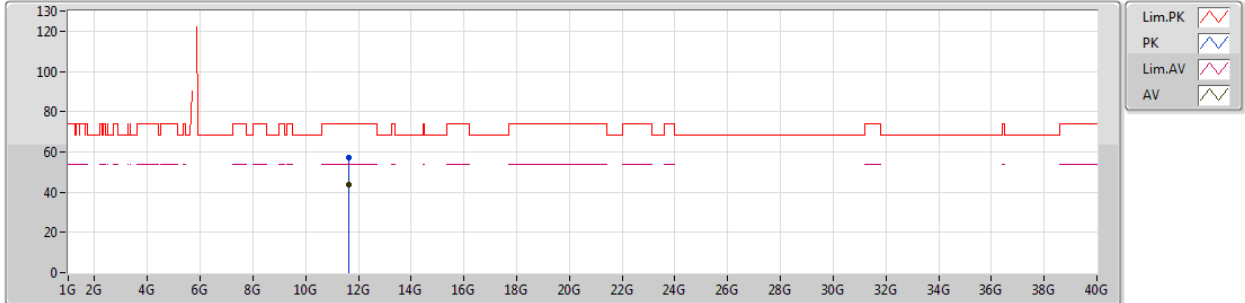

EUT_Z_2TX
Setting 25
03-E-2
FSP

Type	Freq (Hz)	Level (dBuV/m)	Limit (dBuV/m)	Margin (dB)	Factor (dB)	Dist (m)	Condition	Azimuth (°)	Height (m)	Comments
PK	11.64076G	57.22	74.00	-16.78	14.57	3	Horizontal	338	2.11	-
AV	11.64922G	43.53	54.00	-10.47	14.57	3	Horizontal	338	2.11	-

802.11ac VHT40_Nss1,(MCS0)_2TX

25/02/2019

5190MHz_TX

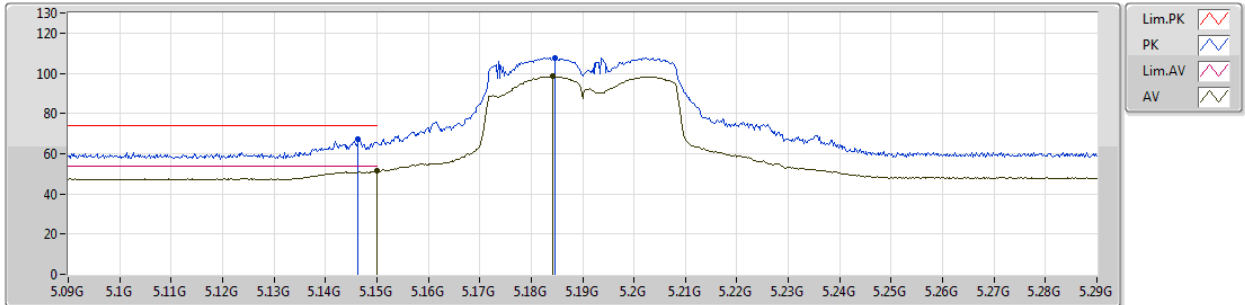

EUT_Z_2TX
Setting 14
06-K-3-10
FSP

Type	Freq (Hz)	Level (dBuV/m)	Limit (dBuV/m)	Margin (dB)	Factor (dB)	Dist (m)	Condition	Azimuth (°)	Height (m)	Comments
PK	5.1464G	67.10	74.00	-6.90	7.27	3	Vertical	236	2.91	-
AV	5.15G	51.41	54.00	-2.59	7.27	3	Vertical	236	2.91	-
PK	5.1846G	107.65	Inf	-Inf	7.34	3	Vertical	236	2.91	-
AV	5.1842G	98.60	Inf	-Inf	7.34	3	Vertical	236	2.91	-

802.11ac VHT40_Nss1,(MCS0)_2TX

25/02/2019

5190MHz_TX

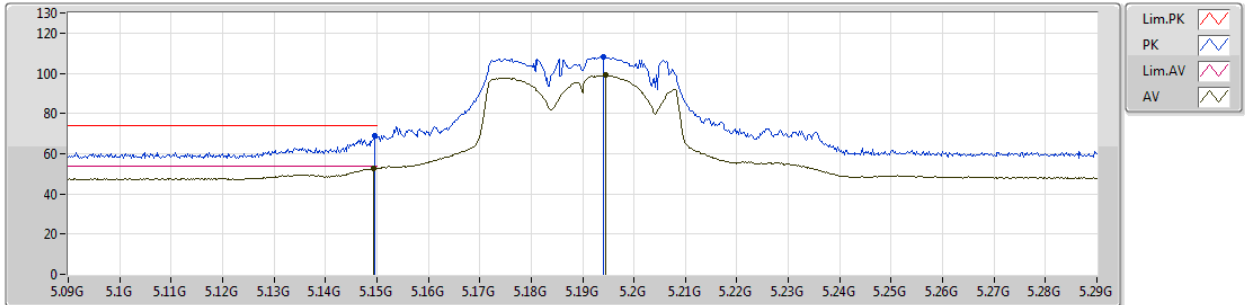

EUT_Z_2TX
Setting 14
06-K-3-10
FSP

Type	Freq (Hz)	Level (dBuV/m)	Limit (dBuV/m)	Margin (dB)	Factor (dB)	Dist (m)	Condition	Azimuth (°)	Height (m)	Comments
PK	5.1496G	69.08	74.00	-4.92	7.27	3	Horizontal	343	1.01	-
AV	5.1494G	52.58	54.00	-1.42	7.27	3	Horizontal	343	1.01	-
PK	5.194G	108.33	Inf	-Inf	7.35	3	Horizontal	343	1.01	-
AV	5.1946G	99.06	Inf	-Inf	7.36	3	Horizontal	343	1.01	-

802.11ac VHT40_Nss1,(MCS0)_2TX

13/02/2019

5190MHz_TX

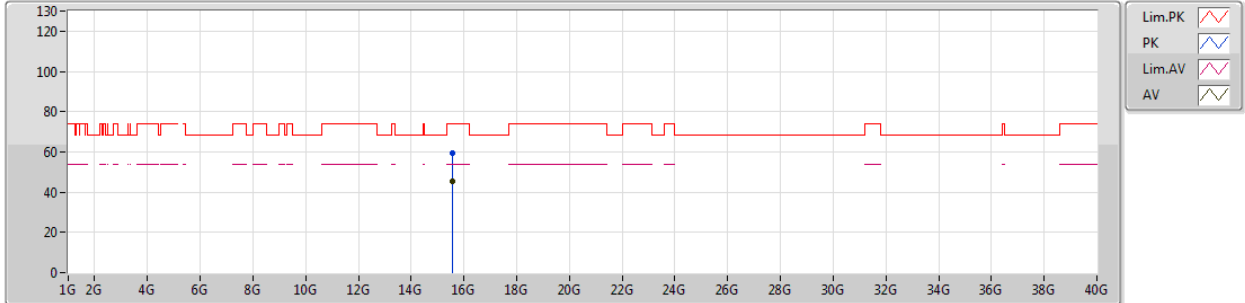

EUT_Z_2TX
Setting 14.5
03-E-2
FSP

Type	Freq (Hz)	Level (dBuV/m)	Limit (dBuV/m)	Margin (dB)	Factor (dB)	Dist (m)	Condition	Azimuth (°)	Height (m)	Comments
PK	15.56214G	59.15	74.00	-14.85	15.17	3	Vertical	349	2.27	-
AV	15.56772G	45.63	54.00	-8.37	15.15	3	Vertical	349	2.27	-

802.11ac VHT40_Nss1,(MCS0)_2TX

13/02/2019

5190MHz_TX

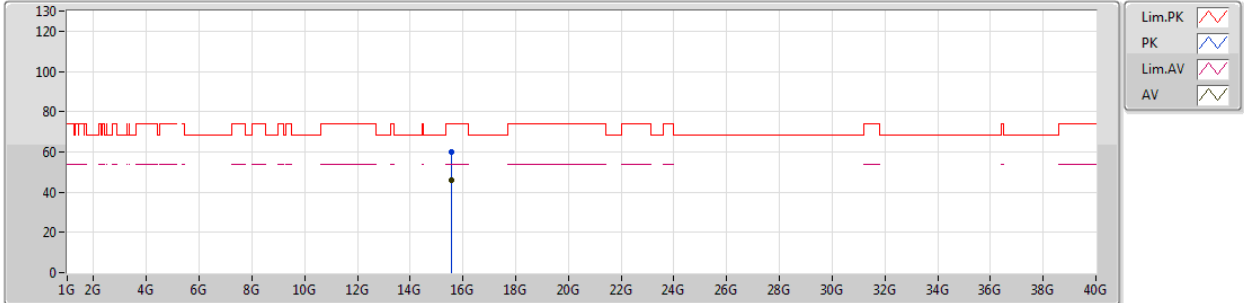

EUT_Z_2TX
Setting 14.5
03-E-2
FSP

Type	Freq (Hz)	Level (dBuV/m)	Limit (dBuV/m)	Margin (dB)	Factor (dB)	Dist (m)	Condition	Azimuth (°)	Height (m)	Comments
PK	15.5628G	59.89	74.00	-14.11	15.17	3	Horizontal	233	1.62	-
AV	15.57273G	45.72	54.00	-8.28	15.14	3	Horizontal	233	1.62	-

802.11ac VHT40_Nss1,(MCS0)_2TX

25/02/2019

5230MHz_TX

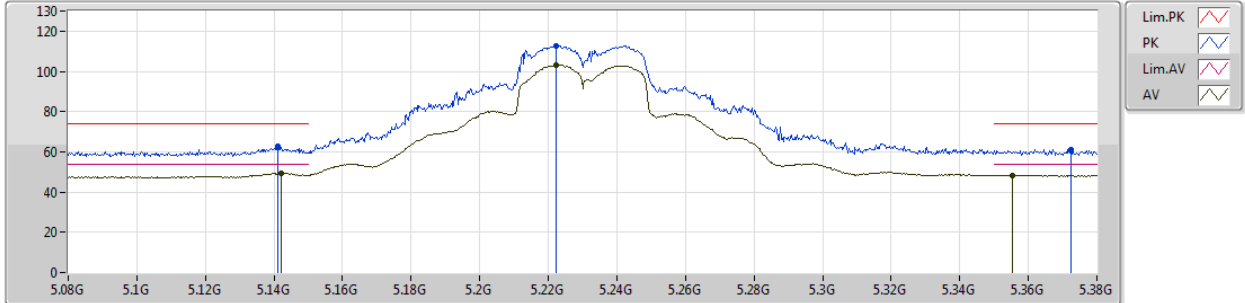

EUT_Z_2TX
Setting 18.5
06-K-3-10
FSP

Type	Freq (Hz)	Level (dBuV/m)	Limit (dBuV/m)	Margin (dB)	Factor (dB)	Dist (m)	Condition	Azimuth (°)	Height (m)	Comments
PK	5.1412G	62.56	74.00	-11.44	7.26	3	Vertical	238	2.89	-
AV	5.1421G	49.52	54.00	-4.48	7.27	3	Vertical	238	2.89	-
PK	5.2222G	112.87	Inf	-Inf	7.38	3	Vertical	238	2.89	-
AV	5.2222G	103.30	Inf	-Inf	7.38	3	Vertical	238	2.89	-
PK	5.3725G	61.32	74.00	-12.68	7.57	3	Vertical	238	2.89	-
AV	5.3554G	48.45	54.00	-5.55	7.55	3	Vertical	238	2.89	-

802.11ac VHT40_Nss1,(MCS0)_2TX

25/02/2019

5230MHz_TX

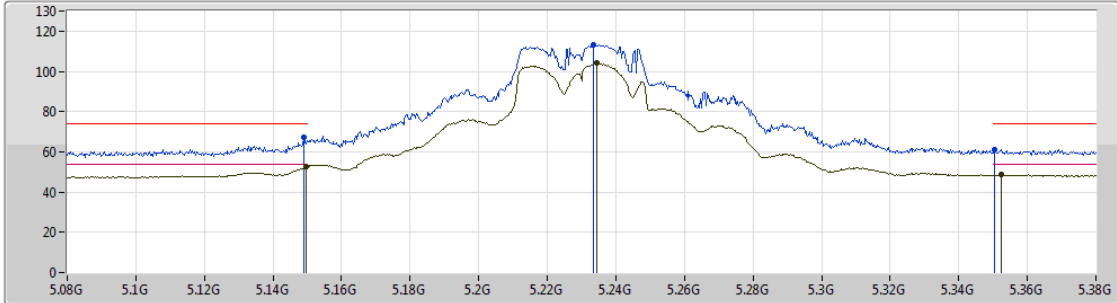

- Lim.PK
- PK
- Lim.AV
- AV

EUT_Z_2TX
Setting 18.5
06-K-3-10
FSP

Type	Freq (Hz)	Level (dBuV/m)	Limit (dBuV/m)	Margin (dB)	Factor (dB)	Dist (m)	Condition	Azimuth (°)	Height (m)	Comments
PK	5.149G	67.13	74.00	-6.87	7.27	3	Horizontal	347	1.03	-
AV	5.1496G	52.64	54.00	-1.36	7.27	3	Horizontal	347	1.03	-
PK	5.2336G	113.27	Inf	-Inf	7.40	3	Horizontal	347	1.03	-
AV	5.2345G	103.97	Inf	-Inf	7.40	3	Horizontal	347	1.03	-
PK	5.3503G	61.06	74.00	-12.94	7.55	3	Horizontal	347	1.03	-
AV	5.3524G	48.60	54.00	-5.40	7.55	3	Horizontal	347	1.03	-

802.11ac VHT40_Nss1,(MCS0)_2TX

13/02/2019

5230MHz_TX



Lim.PK
 PK
 Lim.AV
 AV

EUT_Z_2TX
Setting 19
03-E-2
FSP

Type	Freq	Level	Limit	Margin	Factor	Dist	Condition	Azimuth	Height	Comments
	(Hz)	(dBuV/m)	(dBuV/m)	(dB)	(dB)	(m)		(°)	(m)	
PK	15.70065G	59.28	74.00	-14.72	14.65	3	Vertical	21	1.05	-
AV	15.70197G	46.17	54.00	-7.83	14.64	3	Vertical	21	1.05	-

802.11ac VHT40_Nss1,(MCS0)_2TX

13/02/2019

5230MHz_TX

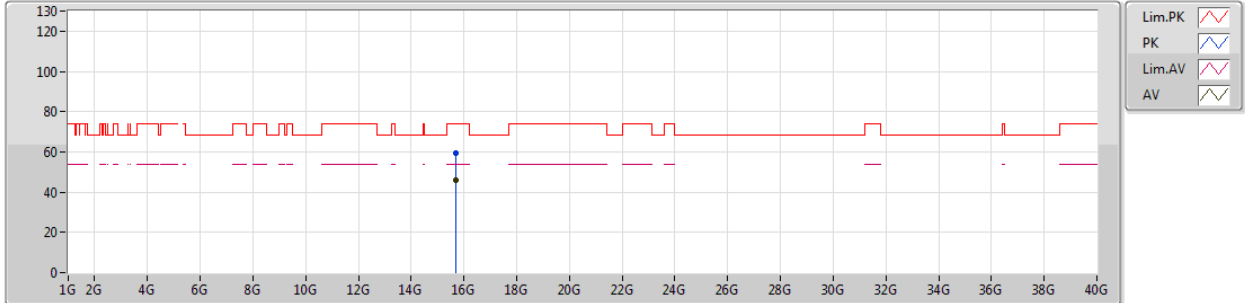

EUT_Z_2TX
Setting 19
03-E-2
FSP

Type	Freq (Hz)	Level (dBuV/m)	Limit (dBuV/m)	Margin (dB)	Factor (dB)	Dist (m)	Condition	Azimuth (°)	Height (m)	Comments
PK	15.69594G	59.67	74.00	-14.33	14.66	3	Horizontal	228	1.75	-
AV	15.69648G	46.21	54.00	-7.79	14.66	3	Horizontal	228	1.75	-

802.11ac VHT40_Nss1,(MCS0)_2TX

26/02/2019

5755MHz_TX

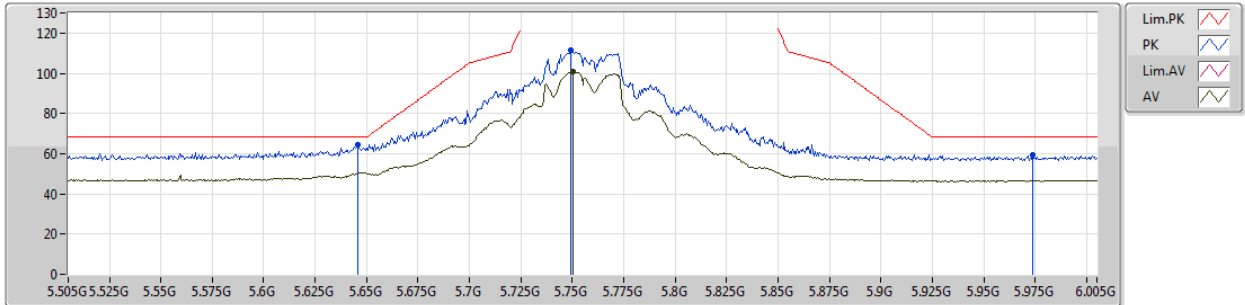

EUT_Z_2TX
Setting 24.5
03-E-2-10
FSP

Type	Freq (Hz)	Level (dBuV/m)	Limit (dBuV/m)	Margin (dB)	Factor (dB)	Dist (m)	Condition	Azimuth (°)	Height (m)	Comments
PK	5.6455G	64.43	68.20	-3.77	6.37	3	Vertical	221	2.58	-
PK	5.7495G	111.24	Inf	-Inf	6.41	3	Vertical	221	2.58	-
AV	5.7505G	100.78	Inf	-Inf	6.42	3	Vertical	221	2.58	-
PK	5.974G	59.27	68.20	-8.93	6.98	3	Vertical	221	2.58	-

802.11ac VHT40_Nss1,(MCS0)_2TX

26/02/2019

5755MHz_TX

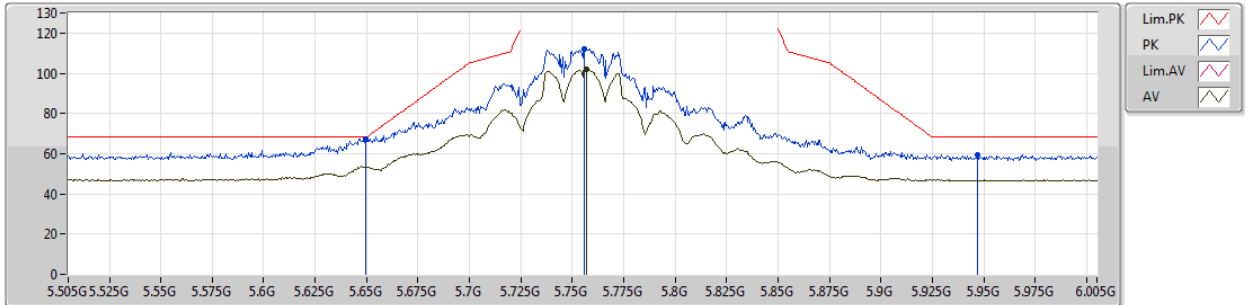

EUT_Z_2TX
Setting 24.5
03-E-2-10
FSP

Type	Freq (Hz)	Level (dBuV/m)	Limit (dBuV/m)	Margin (dB)	Factor (dB)	Dist (m)	Condition	Azimuth (°)	Height (m)	Comments
PK	5.6495G	67.19	68.20	-1.01	6.37	3	Horizontal	334	1.01	-
PK	5.756G	112.25	Inf	-Inf	6.42	3	Horizontal	334	1.01	-
AV	5.757G	102.03	Inf	-Inf	6.42	3	Horizontal	334	1.01	-
PK	5.947G	59.43	68.20	-8.77	6.89	3	Horizontal	334	1.01	-

802.11ac VHT40_Nss1,(MCS0)_2TX

13/02/2019

5755MHz_TX

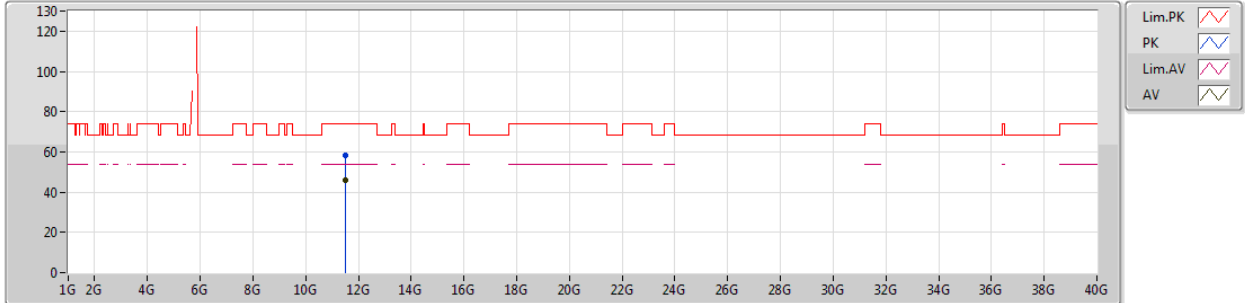

EUT_Z_2TX
Setting 25
03-E-2
FSP

Type	Freq (Hz)	Level (dBuV/m)	Limit (dBuV/m)	Margin (dB)	Factor (dB)	Dist (m)	Condition	Azimuth (°)	Height (m)	Comments
PK	11.51795G	58.07	74.00	-15.93	14.44	3	Vertical	83	2.19	-
AV	11.50985G	45.84	54.00	-8.16	14.44	3	Vertical	83	2.19	-

802.11ac VHT40_Nss1,(MCS0)_2TX

13/02/2019

5755MHz_TX

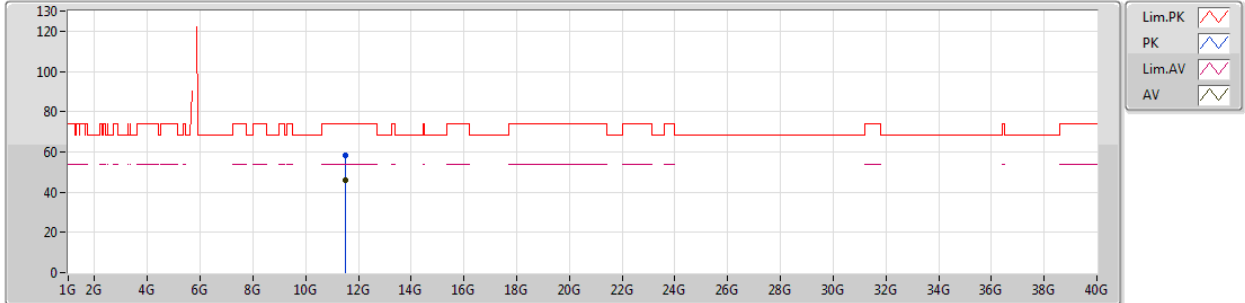

EUT_Z_2TX
Setting 25
03-E-2
FSP

Type	Freq (Hz)	Level (dBuV/m)	Limit (dBuV/m)	Margin (dB)	Factor (dB)	Dist (m)	Condition	Azimuth (°)	Height (m)	Comments
PK	11.51378G	58.52	74.00	-15.48	14.44	3	Horizontal	249	1.51	-
AV	11.50988G	45.68	54.00	-8.32	14.44	3	Horizontal	249	1.51	-

802.11ac VHT40_Nss1,(MCS0)_2TX

13/02/2019

5795MHz_TX

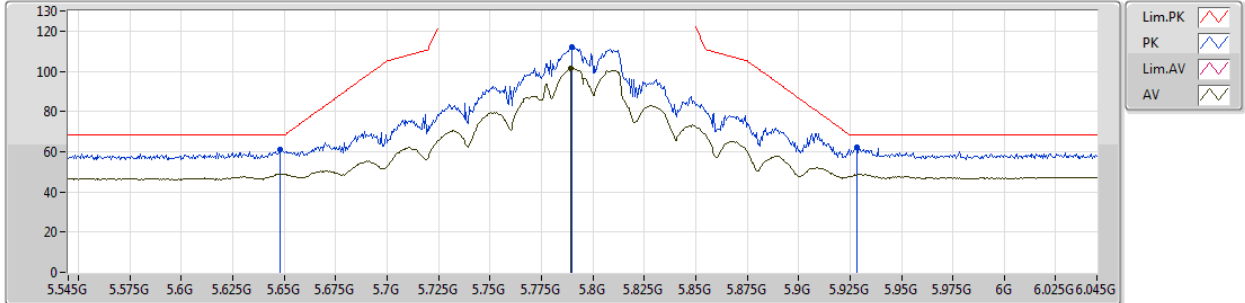

EUT_Z_2TX
Setting 25
03-E-2-10
FSP

Type	Freq (Hz)	Level (dBuV/m)	Limit (dBuV/m)	Margin (dB)	Factor (dB)	Dist (m)	Condition	Azimuth (°)	Height (m)	Comments
PK	5.648G	60.80	68.20	-7.40	6.37	3	Vertical	228	2.54	-
PK	5.79G	112.10	Inf	-Inf	6.45	3	Vertical	228	2.54	-
AV	5.789G	101.31	Inf	-Inf	6.45	3	Vertical	228	2.54	-
PK	5.9285G	62.40	68.20	-5.80	6.83	3	Vertical	228	2.54	-

802.11ac VHT40_Nss1,(MCS0)_2TX

13/02/2019

5795MHz_TX

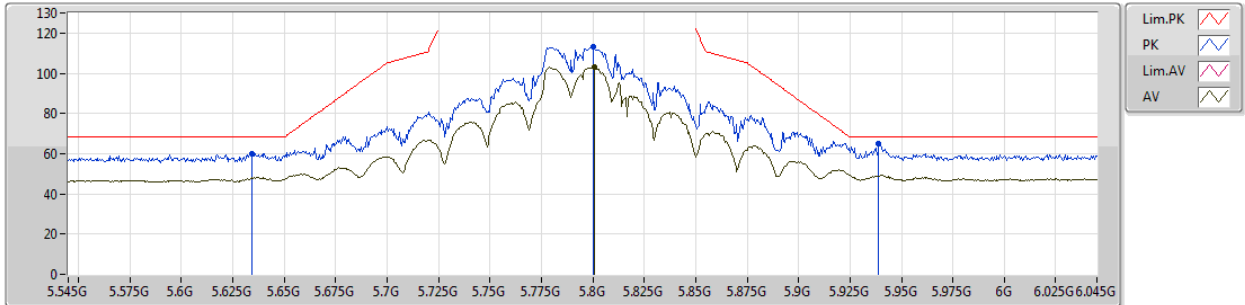

EUT_Z_2TX
Setting 25
03-E-2-10
FSP

Type	Freq (Hz)	Level (dBuV/m)	Limit (dBuV/m)	Margin (dB)	Factor (dB)	Dist (m)	Condition	Azimuth (°)	Height (m)	Comments
PK	5.6345G	60.13	68.20	-8.07	6.38	3	Horizontal	341	1.01	-
PK	5.8G	113.22	Inf	-Inf	6.46	3	Horizontal	341	1.01	-
AV	5.8005G	102.98	Inf	-Inf	6.46	3	Horizontal	341	1.01	-
PK	5.939G	65.13	68.20	-3.07	6.87	3	Horizontal	341	1.01	-

802.11ac VHT40_Nss1,(MCS0)_2TX

13/02/2019

5795MHz_TX

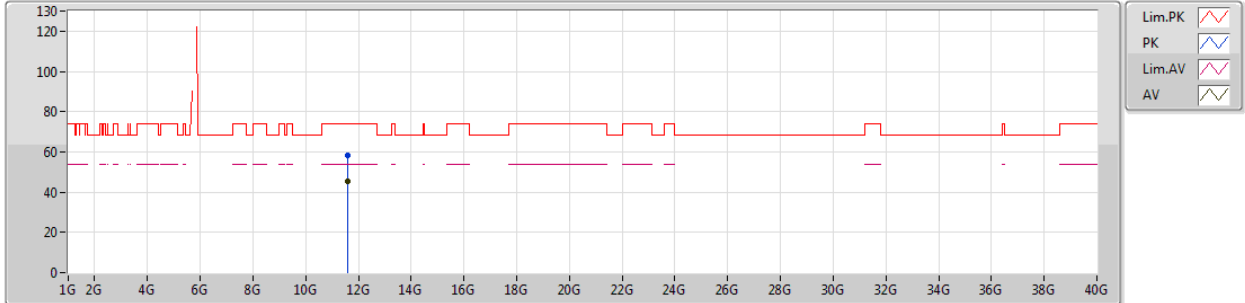

EUT_Z_2TX
Setting 25
03-E-2
FSP

Type	Freq	Level	Limit	Margin	Factor	Dist	Condition	Azimuth	Height	Comments
	(Hz)	(dBuV/m)	(dBuV/m)	(dB)	(dB)	(m)		(°)	(m)	
PK	11.5939G	58.27	74.00	-15.73	14.52	3	Vertical	77	2.03	-
AV	11.59006G	45.49	54.00	-8.51	14.51	3	Vertical	77	2.03	-

802.11ac VHT40_Nss1,(MCS0)_2TX

13/02/2019

5795MHz_TX

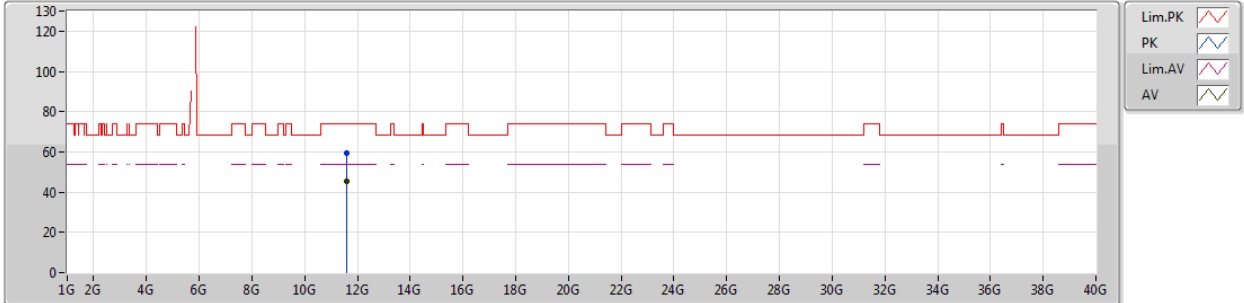

EUT_Z_2TX
Setting 25
03-E-2
FSP

Type	Freq	Level	Limit	Margin	Factor	Dist	Condition	Azimuth	Height	Comments
	(Hz)	(dBuV/m)	(dBuV/m)	(dB)	(dB)	(m)		(°)	(m)	
PK	11.59615G	59.20	74.00	-14.80	14.52	3	Horizontal	286	1.40	-
AV	11.58985G	45.51	54.00	-8.49	14.51	3	Horizontal	286	1.40	-

802.11ac VHT80_Nss1,(MCS0)_2TX

26/02/2019

5210MHz_TX

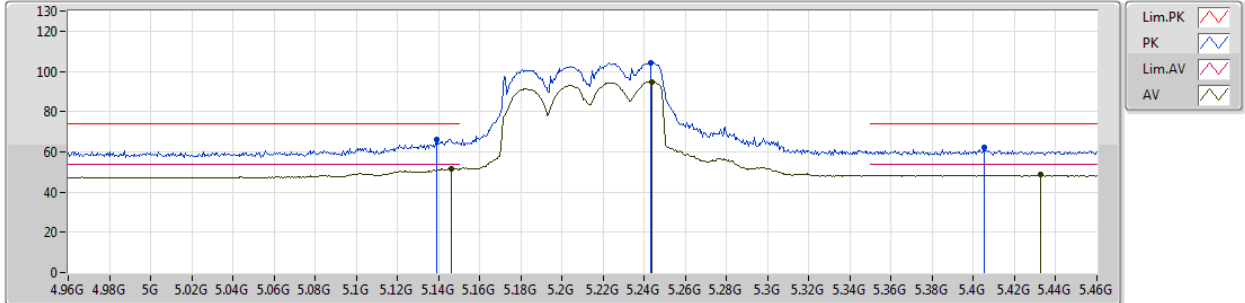

EUT_Z_2TX
Setting 13.5
06-K-3-10
FSP

Type	Freq (Hz)	Level (dBuV/m)	Limit (dBuV/m)	Margin (dB)	Factor (dB)	Dist (m)	Condition	Azimuth (°)	Height (m)	Comments
PK	5.139G	66.20	74.00	-7.80	7.26	3	Vertical	238	2.86	-
AV	5.146G	51.69	54.00	-2.31	7.27	3	Vertical	238	2.86	-
PK	5.243G	104.34	Inf	-Inf	7.42	3	Vertical	238	2.86	-
AV	5.2435G	94.90	Inf	-Inf	7.42	3	Vertical	238	2.86	-
PK	5.405G	62.47	74.00	-11.53	7.61	3	Vertical	238	2.86	-
AV	5.4325G	48.53	54.00	-5.47	7.66	3	Vertical	238	2.86	-

802.11ac VHT80_Nss1,(MCS0)_2TX

26/02/2019

5210MHz_TX

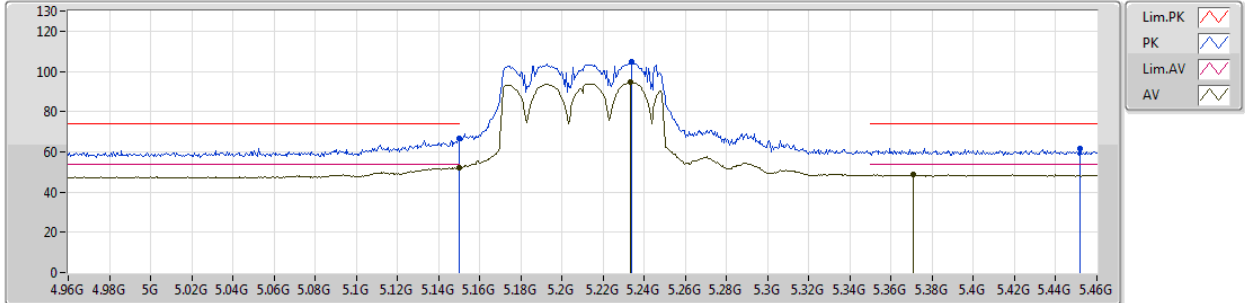

EUT_Z_2TX
Setting 13.5
06-K-3-10
FSP

Type	Freq (Hz)	Level (dBuV/m)	Limit (dBuV/m)	Margin (dB)	Factor (dB)	Dist (m)	Condition	Azimuth (°)	Height (m)	Comments
PK	5.15G	66.61	74.00	-7.39	7.27	3	Horizontal	340	1.10	-
AV	5.15G	52.37	54.00	-1.63	7.27	3	Horizontal	340	1.10	-
PK	5.234G	104.80	Inf	-Inf	7.40	3	Horizontal	340	1.10	-
AV	5.2335G	94.86	Inf	-Inf	7.40	3	Horizontal	340	1.10	-
PK	5.452G	61.64	74.00	-12.36	7.69	3	Horizontal	340	1.10	-
AV	5.3705G	48.79	54.00	-5.21	7.57	3	Horizontal	340	1.10	-

802.11ac VHT80_Nss1,(MCS0)_2TX

13/02/2019

5210MHz_TX

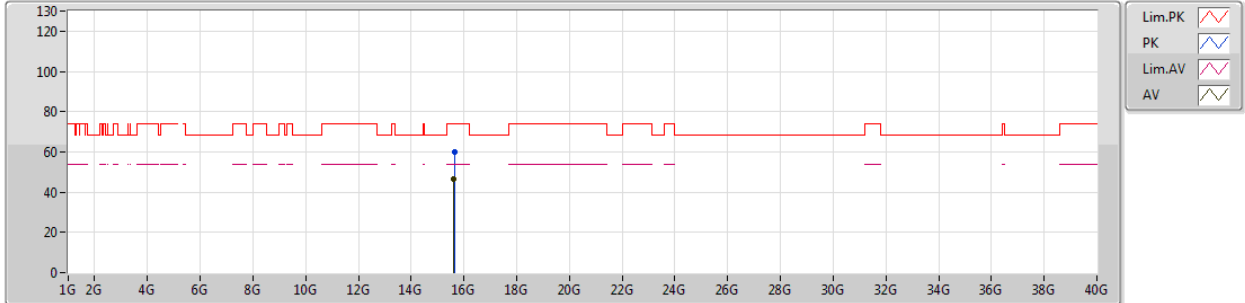

EUT_Z_2TX
Setting 14
03-E-2
FSP

Type	Freq (Hz)	Level (dBuV/m)	Limit (dBuV/m)	Margin (dB)	Factor (dB)	Dist (m)	Condition	Azimuth (°)	Height (m)	Comments
PK	15.63258G	60.03	74.00	-13.97	14.91	3	Vertical	159	2.11	-
AV	15.62796G	46.46	54.00	-7.54	14.93	3	Vertical	159	2.11	-

802.11ac VHT80_Nss1,(MCS0)_2TX

13/02/2019

5210MHz_TX

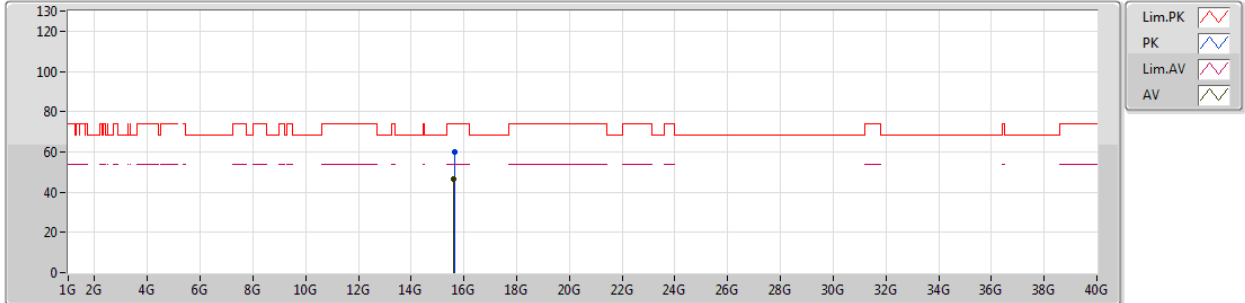

EUT_Z_2TX
Setting 14
03-E-2
FSP

Type	Freq (Hz)	Level (dBuV/m)	Limit (dBuV/m)	Margin (dB)	Factor (dB)	Dist (m)	Condition	Azimuth (°)	Height (m)	Comments
PK	15.63291 G	59.83	74.00	-14.17	14.91	3	Horizontal	153	2.43	-
AV	15.62475 G	46.38	54.00	-7.62	14.95	3	Horizontal	153	2.43	-



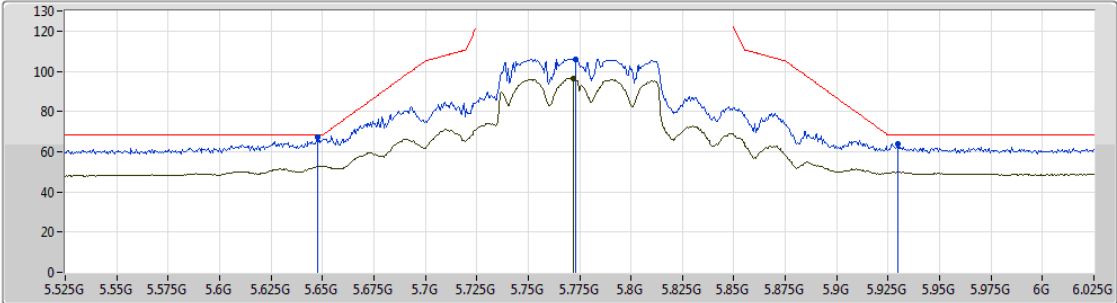

802.11ac VHT80_Nss1,(MCS0)_2TX

26/02/2019

5775MHz_TX



Legend for the spectrum plot:

- Lim.PK 
- PK 
- Lim.AV 
- AV 

EUT_Z_2TX
Setting 18.5
06-K-3-10
FSP

Type	Freq (Hz)	Level (dBuV/m)	Limit (dBuV/m)	Margin (dB)	Factor (dB)	Dist (m)	Condition	Azimuth (°)	Height (m)	Comments
PK	5.6475G	66.99	68.20	-1.21	8.03	3	Vertical	221	2.67	-
PK	5.773G	106.13	Inf	-Inf	8.22	3	Vertical	221	2.67	-
AV	5.772G	96.46	Inf	-Inf	8.22	3	Vertical	221	2.67	-
PK	5.9295G	64.04	68.20	-4.16	8.57	3	Vertical	221	2.67	-

802.11ac VHT80_Nss1,(MCS0)_2TX

26/02/2019

5775MHz_TX

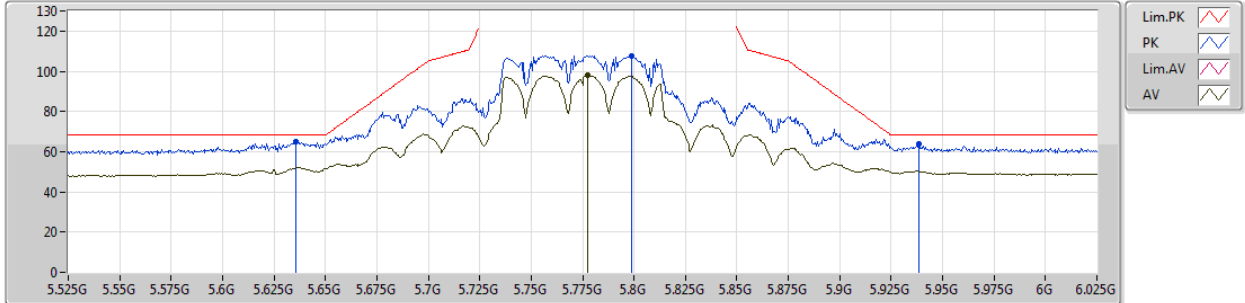

EUT Z_2TX
Setting 18.5
06-K-3-10
FSP

Type	Freq (Hz)	Level (dBuV/m)	Limit (dBuV/m)	Margin (dB)	Factor (dB)	Dist (m)	Condition	Azimuth (°)	Height (m)	Comments
PK	5.6355G	64.99	68.20	-3.21	8.01	3	Horizontal	333	2.99	-
PK	5.799G	107.75	Inf	-Inf	8.27	3	Horizontal	333	2.99	-
AV	5.7775G	97.88	Inf	-Inf	8.24	3	Horizontal	333	2.99	-
PK	5.9385G	63.79	68.20	-4.41	8.58	3	Horizontal	333	2.99	-

802.11ac VHT80_Nss1,(MCS0)_2TX

12/02/2019

5775MHz_TX

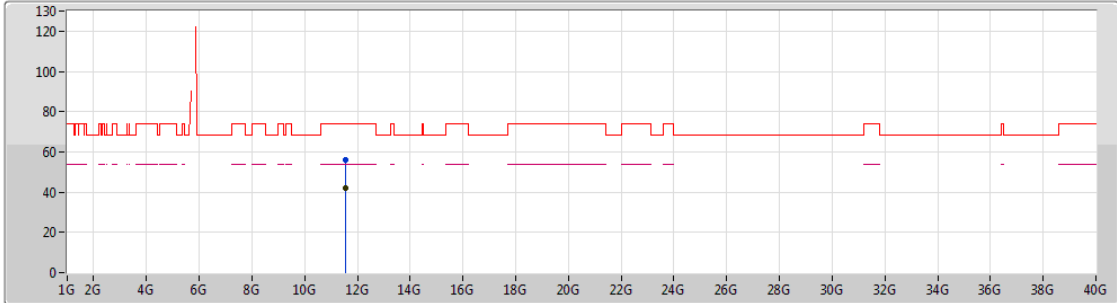

Lim.PK
 PK
 Lim.AV
 AV

EUT_Z_2TX
 Setting 19.5
 03-E-2
 FSP

Type	Freq (Hz)	Level (dBuV/m)	Limit (dBuV/m)	Margin (dB)	Factor (dB)	Dist (m)	Condition	Azimuth (°)	Height (m)	Comments
PK	11.55099G	55.83	74.00	-18.17	14.48	3	Vertical	360	2.04	-
AV	11.53647G	42.19	54.00	-11.81	14.46	3	Vertical	360	2.04	-

802.11ac VHT80_Nss1,(MCS0)_2TX

12/02/2019

5775MHz_TX

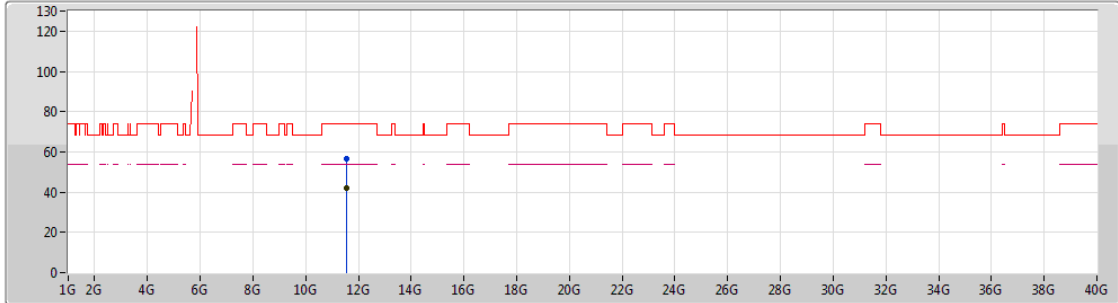

EUT_Z_2TX
Setting 19.5
03-E-2
FSP

Type	Freq (Hz)	Level (dBuV/m)	Limit (dBuV/m)	Margin (dB)	Factor (dB)	Dist (m)	Condition	Azimuth (°)	Height (m)	Comments
PK	11.54376G	56.77	74.00	-17.23	14.46	3	Horizontal	137	1.24	-
AV	11.53878G	42.29	54.00	-11.71	14.46	3	Horizontal	137	1.24	-