

FCC RF Test Report

APPLICANT : NetComm Wireless Limited
EQUIPMENT : LTE WiFi Router (LTE Band 4/Band 17)
BRAND NAME : NetComm Wireless
MODEL NAME : 4G100W-01
MARKETING NAME : LTE WIFI ROUTER
FCC ID : XIA-4G100W
STANDARD : FCC Part 15 Subpart C §15.247
CLASSIFICATION : (DTS) Digital Transmission System

The product was received on Jul. 25, 2012 and completely tested on Sep. 06, 2012. We, SPORTON INTERNATIONAL INC., would like to declare that the tested sample has been evaluated in accordance with the procedures and shown the compliance with the applicable technical standards.

The test results in this report apply exclusively to the tested model / sample. Without written approval of SPORTON INTERNATIONAL INC., the test report shall not be reproduced except in full.

Reviewed by:



Jones Tsai / Manager



SPORTON INTERNATIONAL INC.

No. 52, Hwa Ya 1st Rd., Hwa Ya Technology Park, Kwei-Shan Hsiang, Tao Yuan Hsien, Taiwan, R.O.C.



TABLE OF CONTENTS

REVISION HISTORY 3

SUMMARY OF TEST RESULT 4

1 GENERAL DESCRIPTION 5

 1.1 Applicant 5

 1.2 Manufacturer 5

 1.3 Feature of Equipment Under Test 5

 1.4 Testing Site 7

 1.5 Applied Standards 7

 1.6 Ancillary Equipment List 8

2 TEST CONFIGURATION OF EQUIPMENT UNDER TEST 9

 2.1 Carrier Frequency and Channel 9

 2.2 Pre-Scanned RF Power 10

 2.3 Test Mode 15

 2.4 Connection Diagram of Test System 16

 2.5 RF Utility 17

3 TEST RESULT 18

 3.1 6dB and 99% Bandwidth Measurement 18

 3.2 Output Power Measurement 63

 3.3 Power Spectral Density Measurement 70

 3.4 Conducted Band Edges and Spurious Emission Measurement 94

 3.5 Radiated Band Edges and Spurious Emission Measurement 143

 3.6 AC Conducted Emission Measurement 195

 3.7 Antenna Requirements 199

4 LIST OF MEASURING EQUIPMENT 200

5 UNCERTAINTY OF EVALUATION 201

APPENDIX A. PHOTOGRAPHS OF EUT

APPENDIX B. SETUP PHOTOGRAPHS

SUMMARY OF TEST RESULT

Report Section	FCC Rule	IC Rule	Description	Limit	Result	Remark
3.1	15.247(a)(2)	A8.2(a)	6dB Bandwidth	$\geq 0.5\text{MHz}$	Pass	-
3.1	-	Gen 4.6.1	99% Bandwidth	-	Pass	-
3.2	15.247(b)	A8.4	Power Output Measurement	$\leq 30\text{dBm}$	Pass	-
3.3	15.247(e)	A8.2(b)	Power Spectral Density	$\leq 8\text{dBm}/3\text{kHz}$	Pass	-
3.4	15.247(d)	A8.5	Conducted Band Edges	$\leq 20\text{dBc}$	Pass	
			Conducted Spurious Emission		Pass	
3.5	15.247(d)	A8.5	Radiated Band Edges	15.209(a) & 15.247(d)	Pass	
			Radiated Spurious Emission		Pass	Under limit 1.01 dB at 4874.000 MHz
3.6	15.207	Gen 7.2.4	AC Conducted Emission	15.207(a)	Pass	Under limit 9.80 dB at 0.470 MHz
3.6	15.203 & 15.247(b)	A8.4	Antenna Requirement	N/A	Pass	-



1 General Description

1.1 Applicant

NetComm Wireless Limited

Level 2, 18-20 Orion Road Lane Cove, NSW Australia

1.2 Manufacturer

NetComm Wireless Limited

Level 2, 18-20 Orion Road Lane Cove, NSW Australia

1.3 Feature of Equipment Under Test

Product Feature	
Equipment	LTE WiFi Router (LTE Band 4/Band 17)
Brand Name	NetComm Wireless
Model Name	4G100W-01
Marketing Name	LTE WiFi Router
FCC ID	XIA-4G100W
Radios application	GSM/EGPRS/WCDMA/HSPA/WLAN 11bgn
HW Version	V1.10
SW Version	1.1.18.0
EUT Stage	Identical Prototype

Remark: The above EUT's information was declared by manufacturer. Please refer to the specifications or user's manual for more detailed description.



Product Specification subjective to this standard																						
Tx/Rx Channel Frequency Range	802.11b/g/n : 2412 MHz ~ 2462 MHz																					
Maximum Output Power to Antenna	<p><Ant. 0> 802.11b : 16.54 dBm (0.0451 W) 802.11g : 22.32 dBm (0.1706 W) 802.11n HT-20 : 22.07 dBm (0.1611 W) 802.11n HT-40 : 22.66 dBm (0.1845 W)</p> <p><Ant. 0+1> 802.11b : 15.76 dBm (0.0377 W) 802.11g : 21.68 dBm (0.1472 W) 802.11n HT-20 : 21.93 dBm (0.1560 W) 802.11n HT-40 : 23.60 dBm (0.2291 W)</p>																					
99% Occupied Bandwidth	<p><Ant. 0> 802.11b : 15.05MHz 802.11g : 17.05MHz 802.11n HT-20 : 9.42MHz 802.11n HT-40 : 35.90MHz</p> <p><Ant. 0+1(0)> 802.11b : 15.00MHz 802.11g : 16.90MHz 802.11n HT-20 : 17.85MHz 802.11n HT-40 : 35.80MHz</p> <p><Ant. 0+1(1)> 802.11b : 15.05MHz 802.11g : 16.95MHz 802.11n HT-20 : 17.80MHz 802.11n HT-40 : 35.80MHz</p>																					
Antenna Type	PCB Antenna																					
Antenna Gain	Ant. 0 : 4.20 dBi Ant. 1 : 3.30 dBi																					
Type of Modulation	802.11b : DSSS (BPSK / QPSK / CCK) 802.11g/n : OFDM (BPSK / QPSK / 16QAM / 64QAM)																					
Antenna Function for Transmitter	<table border="1"> <thead> <tr> <th></th> <th>Ant. 0.</th> <th>Ant. 1.</th> </tr> </thead> <tbody> <tr> <td>802.11b SISO</td> <td>V</td> <td>V</td> </tr> <tr> <td>802.11b MIMO</td> <td>V</td> <td>V</td> </tr> <tr> <td>802.11g SISO</td> <td>V</td> <td>V</td> </tr> <tr> <td>802.11g MIMO</td> <td>V</td> <td>V</td> </tr> <tr> <td>802.11n SISO</td> <td>V</td> <td>V</td> </tr> <tr> <td>802.11n MIMO</td> <td>V</td> <td>V</td> </tr> </tbody> </table>		Ant. 0.	Ant. 1.	802.11b SISO	V	V	802.11b MIMO	V	V	802.11g SISO	V	V	802.11g MIMO	V	V	802.11n SISO	V	V	802.11n MIMO	V	V
	Ant. 0.	Ant. 1.																				
802.11b SISO	V	V																				
802.11b MIMO	V	V																				
802.11g SISO	V	V																				
802.11g MIMO	V	V																				
802.11n SISO	V	V																				
802.11n MIMO	V	V																				

1.4 Testing Site

Test Site	SPORTON INTERNATIONAL INC.			
Test Site Location	No. 52, Hwa Ya 1 st Rd., Hwa Ya Technology Park, Kwei-Shan Hsiang, Tao Yuan Hsien, Taiwan, R.O.C. TEL: +886-3-3273456 / FAX: +886-3-3284978			
Test Site No.	Sporton Site No.			FCC/IC Registration No.
	TH02-HY	CO05-HY	03CH06-HY	722060/4086B-1

1.5 Applied Standards

According to the specifications of the manufacturer, the EUT must comply with the requirements of the following standards:

- ♦ FCC Part 15 Subpart C §15.247
- ♦ FCC KDB Publication No. 558074 D01 DTS Meas. Guidance v01
- ♦ TCB Workshop 2012, April
- ♦ ANSI C63.4-2003 and ANSI C63.10-2009
- ♦ IC RSS-210 Issue 8
- ♦ IC RSS-Gen Issue 3

Remark:

1. All test items were verified and recorded according to the standards and without any deviation during the test.
2. This EUT has also been tested and complied with the requirements of FCC Part 15, Subpart B, recorded in a separate test report.



1.6 Ancillary Equipment List

Item	Equipment	Trade Name	Model Name	FCC ID	Data Cable	Power Cord
1.	System Simulator	R&S	CMU 200	N/A	N/A	Unshielded, 1.8 m
2.	Notebook	DELL	P20G	FCC DoC	N/A	AC I/P: Unshielded, 1.2 m DC O/P: Shielded, 1.8 m
3.	Notebook	DELL	Latitude E6320	FCC DoC	N/A	AC I/P: Unshielded, 1.2 m DC O/P: Shielded, 1.8 m
4.	USB3.0 HD	WD	WDBPCK5000ABK-PESN	FCC DoC	Shielded, 0.5 m	N/A

2 Test Configuration of Equipment Under Test

The EUT has been associated with peripherals and configuration operated in a manner tended to maximize its emission characteristics in a typical application. Frequency range investigated: conducted emission (150 KHz to 30 MHz) and radiated emission (9 KHz to the 10th harmonic of the highest fundamental frequency or to 40 GHz, whichever is lower).

The final configuration from all the combinations and the worst-case data rates were investigated by measuring the maximum power across all the data rates and modulation modes under section 2.2.

Based on the worst configuration found above, the RF power setting is set individually to meet FCC compliance limit for the final conducted and radiated tests shown in section 2.3.

2.1 Carrier Frequency and Channel

Frequency Band	Channel	Freq. (MHz)	Channel	Freq. (MHz)
2400-2483.5 MHz	1	2412	7	2442
	2	2417	8	2447
	3	2422	9	2452
	4	2427	10	2457
	5	2432	11	2462
	6	2437		



2.2 Pre-Scanned RF Power

Preliminary tests were performed in different data rate and antenna configurations as following table and the highest power data rates were chosen for full test in the following tables. Final Output Power equals to Measured Output Power adds the duty factor.

SISO <Ant. 0>

802.11b				
Data Rate (MHz)	1M bps	2M bps	5.5M bps	11M bps
Peak Power (dBm)	16.54	16.5	16.52	16.53

802.11g								
Data Rate (MHz)	6M bps	9M bps	12M bps	18M bps	24M bps	36M bps	48M bps	54M bps
Peak Power (dBm)	22.32	22.01	21.99	22.21	22.3	22.31	22.27	22.05

2.4GHz 802.11n HT-20								
Data Rate (MHz)	MCS0	MCS1	MCS2	MCS3	MCS4	MCS5	MCS6	MCS7
Peak Power (dBm)	21.64	21.62	21.58	21.12	21.31	21.44	21.94	22.05
Data Rate (MHz)	MCS8	MCS9	MCS10	MCS11	MCS12	MCS13	MCS14	MCS15
Peak Power (dBm)	21.15	21.19	21.3	21.11	22.06	22.01	21.61	22.07

2.4GHz 802.11n HT-40								
Data Rate (MHz)	MCS0	MCS1	MCS2	MCS3	MCS4	MCS5	MCS6	MCS7
Peak Power (dBm)	21.22	21.21	20.99	21.44	21.12	21.77	21.47	21.19
Data Rate (MHz)	MCS8	MCS9	MCS10	MCS11	MCS12	MCS13	MCS14	MCS15
Peak Power (dBm)	20.88	20.48	20.51	21.33	22.66	21.72	21.38	21.33



SISO <Ant. 1>

802.11b				
Data Rate (MHz)	1M bps	2M bps	5.5M bps	11M bps
Peak Power (dBm)	3.53	3.49	3.52	3.42

802.11g								
Data Rate (MHz)	6M bps	9M bps	12M bps	18M bps	24M bps	36M bps	48M bps	54M bps
Peak Power (dBm)	12.12	11.51	11.76	11.75	11.99	11.82	12.11	12.05

2.4GHz 802.11n HT-20								
Data Rate (MHz)	MCS0	MCS1	MCS2	MCS3	MCS4	MCS5	MCS6	MCS7
Peak Power (dBm)	12.55	12.42	12.46	12.04	11.95	12.39	12.43	12.3
Data Rate (MHz)	MCS8	MCS9	MCS10	MCS11	MCS12	MCS13	MCS14	MCS15
Peak Power (dBm)	11.91	12.41	12.05	12.21	12.19	12.67	12.43	12.76

2.4GHz 802.11n HT-40								
Data Rate (MHz)	MCS0	MCS1	MCS2	MCS3	MCS4	MCS5	MCS6	MCS7
Peak Power (dBm)	12.91	12.81	12.88	12.87	12.82	13.23	13.13	13
Data Rate (MHz)	MCS8	MCS9	MCS10	MCS11	MCS12	MCS13	MCS14	MCS15
Peak Power (dBm)	12.76	12.51	12.52	12.85	14.34	12.78	13.13	13.14



MIMO <Ant. 0+1(0)>

802.11b				
Data Rate (MHz)	1M bps	2M bps	5.5M bps	11M bps
Peak Power (dBm)	15.22	14.67	14.97	14.75

802.11g								
Data Rate (MHz)	6M bps	9M bps	12M bps	18M bps	24M bps	36M bps	48M bps	54M bps
Peak Power (dBm)	21.23	20.88	20.65	20.56	20.19	19.96	19.77	19.55

2.4GHz 802.11n HT-20								
Data Rate (MHz)	MCS0	MCS1	MCS2	MCS3	MCS4	MCS5	MCS6	MCS7
Peak Power (dBm)	20.58	20.12	20.14	20.22	20.52	20.65	21.20	21.41
Data Rate (MHz)	MCS8	MCS9	MCS10	MCS11	MCS12	MCS13	MCS14	MCS15
Peak Power (dBm)	20.02	20.86	20.20	20.56	21.33	21.14	21.28	21.33

2.4GHz 802.11n HT-40								
Data Rate (MHz)	MCS0	MCS1	MCS2	MCS3	MCS4	MCS5	MCS6	MCS7
Peak Power (dBm)	20.73	20.97	20.73	21.34	21.04	22.54	21.91	21.21
Data Rate (MHz)	MCS8	MCS9	MCS10	MCS11	MCS12	MCS13	MCS14	MCS15
Peak Power (dBm)	21.11	20.62	20.91	21.31	23.00	22.22	21.94	21.72



MIMO <Ant. 0+1(1)>

802.11b				
Data Rate (MHz)	1M bps	2M bps	5.5M bps	11M bps
Peak Power (dBm)	6.46	6.38	6.39	6.18

802.11g								
Data Rate (MHz)	6M bps	9M bps	12M bps	18M bps	24M bps	36M bps	48M bps	54M bps
Peak Power (dBm)	11.65	11.40	10.35	10.01	10.12	9.87	9.63	10.02

2.4GHz 802.11n HT-20								
Data Rate (MHz)	MCS0	MCS1	MCS2	MCS3	MCS4	MCS5	MCS6	MCS7
Peak Power (dBm)	12.45	11.54	11.62	11.50	11.44	11.88	12.10	12.22
Data Rate (MHz)	MCS8	MCS9	MCS10	MCS11	MCS12	MCS13	MCS14	MCS15
Peak Power (dBm)	12.35	12.03	11.66	12.19	12.01	12.91	12.42	13.01

2.4GHz 802.11n HT-40								
Data Rate (MHz)	MCS0	MCS1	MCS2	MCS3	MCS4	MCS5	MCS6	MCS7
Peak Power (dBm)	11.57	12.25	12.17	12.39	12.36	13.35	12.63	12.84
Data Rate (MHz)	MCS8	MCS9	MCS10	MCS11	MCS12	MCS13	MCS14	MCS15
Peak Power (dBm)	11.72	11.28	11.82	12.01	14.73	13.01	13.10	12.71



MIMO <Ant. 0+1>

802.11b				
Data Rate (MHz)	1M bps	2M bps	5.5M bps	11M bps
Peak Power (dBm)	15.76	15.27	15.53	15.32

802.11g								
Data Rate (MHz)	6M bps	9M bps	12M bps	18M bps	24M bps	36M bps	48M bps	54M bps
Peak Power (dBm)	21.68	21.34	21.04	20.93	20.60	20.37	20.17	20.01

2.4GHz 802.11n HT-20								
Data Rate (MHz)	MCS0	MCS1	MCS2	MCS3	MCS4	MCS5	MCS6	MCS7
Peak Power (dBm)	21.20	20.68	20.71	20.77	21.03	21.19	21.70	21.90
Data Rate (MHz)	MCS8	MCS9	MCS10	MCS11	MCS12	MCS13	MCS14	MCS15
Peak Power (dBm)	20.71	21.39	20.77	21.15	21.81	21.75	21.81	21.93

2.4GHz 802.11n HT-40								
Data Rate (MHz)	MCS0	MCS1	MCS2	MCS3	MCS4	MCS5	MCS6	MCS7
Peak Power (dBm)	21.23	21.52	21.30	21.86	21.59	23.03	22.39	21.80
Data Rate (MHz)	MCS8	MCS9	MCS10	MCS11	MCS12	MCS13	MCS14	MCS15
Peak Power (dBm)	21.58	21.10	21.41	21.79	23.60	22.71	22.47	22.23

Note: MIMO Ant. 0+1 is a calculated result from sum of the power MIMO Ant. 0 and MIMO. Ant. 1.

2.3 Test Mode

Final results of test modes, data rates and test channels are shown as following table.

Test Cases				
	Test Items	Mode	Data Rate	Test Channel
Conducted TCs	6dB and 99% BW Power Spectral Density	802.11b	1 Mbps	1/6/11
		802.11g	6 Mbps	1/6/11
		802.11n HT-20	6.5 Mbps	1/6/11
		802.11n HT-40	13.5 Mbps	3/6/9
	Output Power	802.11b	1 Mbps	1/6/11
		802.11g	6 Mbps	1/6/11
		802.11n HT-20	6.5 Mbps	1/6/11
		802.11n HT-40	13.5 Mbps	3/6/9
	Conducted Band EDGE	802.11b	1 Mbps	1/11
		802.11g	6 Mbps	1/11
		802.11n HT-20	6.5 Mbps	1/11
		802.11n HT-40	13.5 Mbps	3/9
	Conducted Spurious Emission	802.11b	1 Mbps	1/6/11
		802.11g	6 Mbps	1/6/11
		802.11n HT-20	6.5 Mbps	1/6/11
		802.11n HT-40	13.5 Mbps	3/6/9
Radiated TCs	Radiated Band EDGE	802.11b	1 Mbps	1/11
		802.11g	6 Mbps	1/11
		802.11n HT-20	6.5 Mbps	1/11
		802.11n HT-40	13.5 Mbps	3/9
	Radiated Spurious Emission	802.11b	1 Mbps	1/6/11
		802.11g	6 Mbps	1/6/11
		802.11n HT-20	6.5 Mbps	1/6/11
		802.11n HT-40	13.5 Mbps	3/6/9

Test Cases	
AC Conducted Emission	Mode 1 : LTE Band 17 Idle + WLAN Link + LAN Link + WAN Link + USB 3.0 HD + Adapter

2.4 Connection Diagram of Test System

<WLAN Tx Mode>

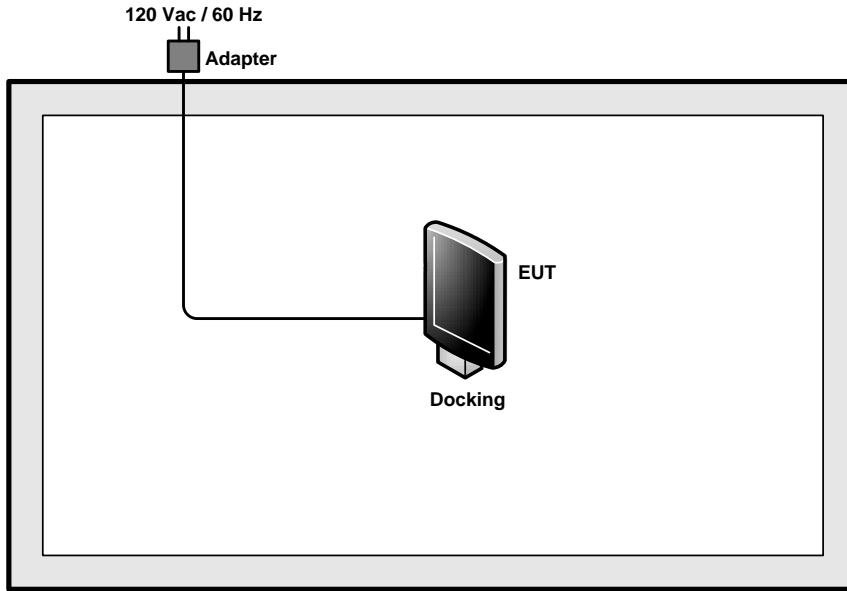

<AC Conducted Emission Mode>

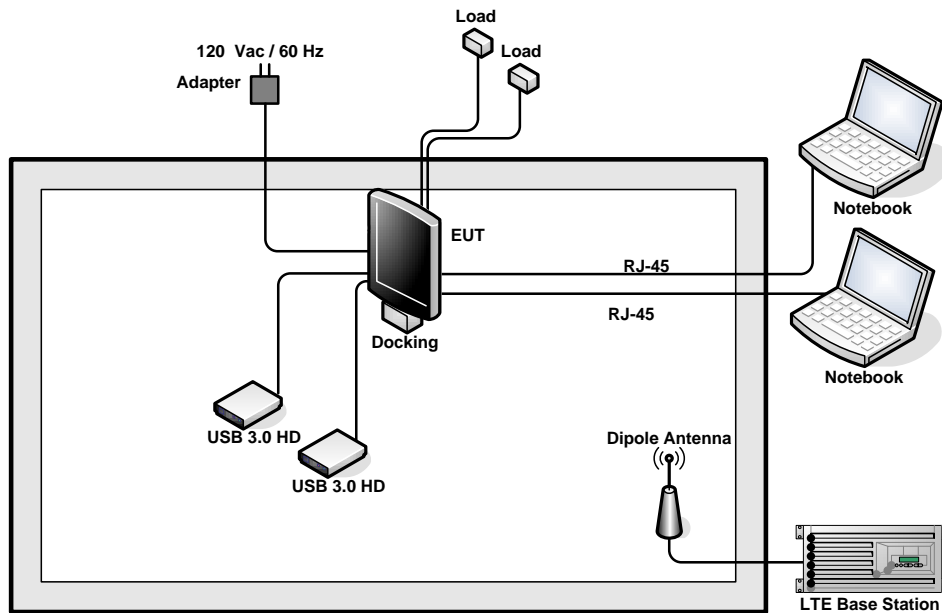



2.5 RF Utility

Programmed RF utility, "Ralink QA Test Program for RT3352" installed in notebook make the EUT provides functions like channel selection and power level for transmitting and receiving signals continuously.

3 Test Result

3.1 6dB and 99% Bandwidth Measurement

3.1.1 Limit of 6dB Bandwidth

The minimum 6 dB bandwidth shall be at least 500 KHz.

3.1.2 Measuring Instruments

See list of measuring instruments of this test report.

3.1.3 Test Procedures

1. The testing follows FCC KDB Publication No. 558074 D01 DTS Meas. Guidance and TCB Workshop 2012, April.
2. The RF output of EUT was connected to the spectrum analyzer by a low loss cable. The path loss was compensated to the results for each measurement.
3. Set to the maximum power setting and enable the EUT transmit continuously.
4. Make the measurement with the spectrum analyzer's resolution bandwidth (RBW) = 1-5% of the emission bandwidth (EBW). Set the Video bandwidth (VBW) $\geq 3 * RBW$. In order to make an accurate measurement. The 6 dB bandwidth must be greater than 500 KHz.

3.1.4 Test Setup

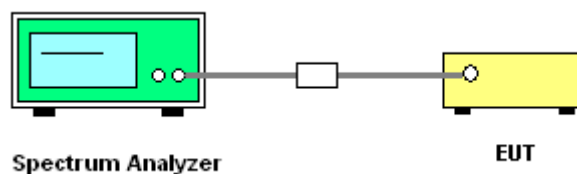



3.1.5 Test Result of 6dB Bandwidth

Test Mode :	802.11b	Temperature :	24~26°C
Test Engineer :	Bill Kuo	Relative Humidity :	55~58%

Channel	Frequency (MHz)	802.11b 6dB Bandwidth (MHz)			6dB Bandwidth Min. Limit (MHz)	Pass/Fail
		SISO Ant. 0	MIMO <Ant. 0+1(0)>	MIMO <Ant. 0+1(1)>		
01	2412	12.04	12.12	12.12	0.5	Pass
06	2437	12.12	12.12	12.08	0.5	Pass
11	2462	12.12	12.08	12.12	0.5	Pass

Test Mode :	802.11g	Temperature :	24~26°C
Test Engineer :	Bill Kuo	Relative Humidity :	55~58%

Channel	Frequency (MHz)	802.11g 6dB Bandwidth (MHz)			6dB Bandwidth Min. Limit (MHz)	Pass/Fail
		SISO Ant. 0	MIMO <Ant. 0+1(0)>	MIMO <Ant. 0+1(1)>		
01	2412	16.24	16.12	16.12	0.5	Pass
06	2437	16.20	16.20	16.20	0.5	Pass
11	2462	16.20	16.16	16.20	0.5	Pass

Test Mode :	802.11n HT-20	Temperature :	24~26°C
Test Engineer :	Bill Kuo	Relative Humidity :	55~58%

Channel	Frequency (MHz)	2.4GHz 802.11n HT-20 6dB Bandwidth (MHz)			6dB Bandwidth Min. Limit (MHz)	Pass/Fail
		SISO Ant. 0	MIMO <Ant. 0+1(0)>	MIMO <Ant. 0+1(1)>		
01	2412	17.16	17.20	17.00	0.5	Pass
06	2437	17.12	17.08	16.90	0.5	Pass
11	2462	17.20	17.20	17.04	0.5	Pass



Test Mode :	802.11n HT-40	Temperature :	24~26°C
Test Engineer :	Bill Kuo	Relative Humidity :	55~58%

Channel	Frequency (MHz)	2.4GHz 802.11n HT-40 6dB Bandwidth (MHz)			6dB Bandwidth Min. Limit (MHz)	Pass/Fail
		SISO Ant. 0	MIMO <Ant. 0+1(0)>	MIMO <Ant. 0+1(1)>		
03	2422	34.80	34.64	35.36	0.5	Pass
06	2437	35.04	35.12	35.04	0.5	Pass
09	2452	35.12	35.12	35.04	0.5	Pass

3.1.6 Test Result of 99% Occupied Bandwith

Test Mode :	802.11b	Temperature :	24~26°C
Test Engineer :	Bill Kuo	Relative Humidity :	55~58%

Channel	Frequency (MHz)	802.11b 99% Occupied Bandwidth (MHz)			Pass/Fail
		SISO Ant. 0	MIMO <Ant. 0+1(0)>	MIMO <Ant. 0+1(1)>	
01	2412	15.05	15.00	15.05	Pass
06	2437	15.00	15.00	15.05	Pass
11	2462	15.00	15.00	15.05	Pass

Test Mode :	802.11g	Temperature :	24~26°C
Test Engineer :	Bill Kuo	Relative Humidity :	55~58%

Channel	Frequency (MHz)	802.11g 99% Occupied Bandwidth (MHz)			Pass/Fail
		SISO Ant. 0	MIMO <Ant. 0+1(0)>	MIMO <Ant. 0+1(1)>	
01	2412	17.05	16.90	16.95	Pass
06	2437	16.95	16.90	16.90	Pass
11	2462	16.85	16.90	16.90	Pass

Test Mode :	802.11n HT-20	Temperature :	24~26°C
Test Engineer :	Bill Kuo	Relative Humidity :	55~58%

Channel	Frequency (MHz)	2.4GHz 802.11n HT-20 99% Occupied Bandwidth (MHz)			Pass/Fail
		SISO Ant. 0	MIMO <Ant. 0+1(0)>	MIMO <Ant. 0+1(1)>	
01	2412	9.28	17.85	17.75	Pass
06	2437	8.93	17.85	17.80	Pass
11	2462	9.42	17.85	17.75	Pass



Test Mode :	802.11n HT-40	Temperature :	24~26°C
Test Engineer :	Bill Kuo	Relative Humidity :	55~58%

Channel	Frequency (MHz)	2.4GHz 802.11n HT-40 99% Occupied Bandwidth (MHz)			Pass/Fail
		SISO Ant. 0	MIMO <Ant. 0+1(0)>	MIMO <Ant. 0+1(1)>	
03	2422	35.90	35.80	35.80	Pass
06	2437	35.80	35.80	35.80	Pass
09	2452	35.70	35.80	35.70	Pass

3.1.7 Test Result of 6dB Bandwidth Plots

802.11b – SISO Ant. 0

6 dB Bandwidth Plot on Channel 01

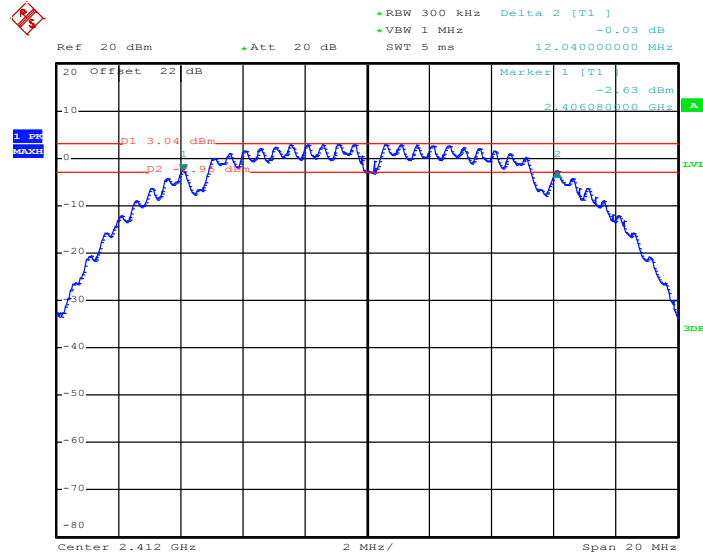

Date: 7.AUG.2012 04:56:37

802.11b – SISO Ant. 0

6 dB Bandwidth Plot on Channel 06

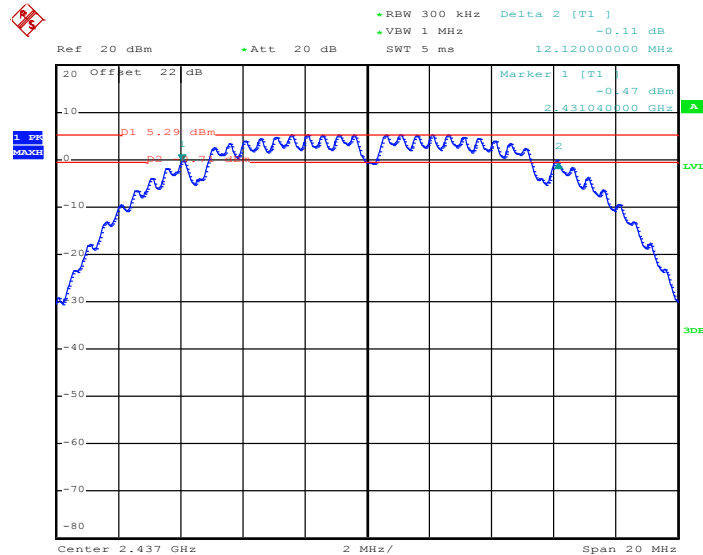

Date: 7.AUG.2012 05:02:07



802.11b – SISO Ant. 0

6 dB Bandwidth Plot on Channel 11

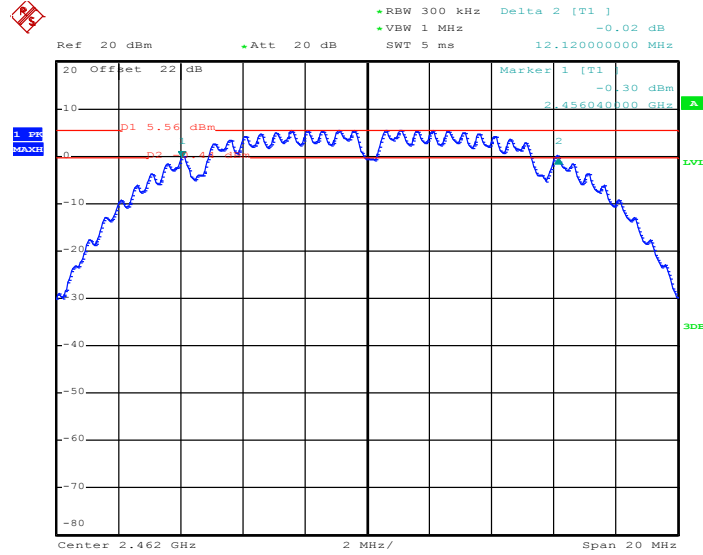

Date: 7.AUG.2012 05:05:36

802.11b – MIMO Ant. 0+1(0)

6 dB Bandwidth Plot on Channel 01

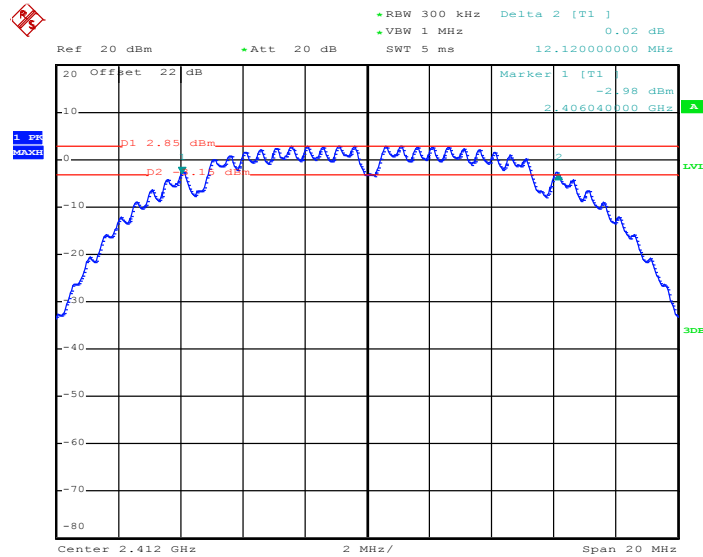

Date: 7.AUG.2012 05:19:03



802.11b – MIMO Ant. 0+1(0)

6 dB Bandwidth Plot on Channel 06

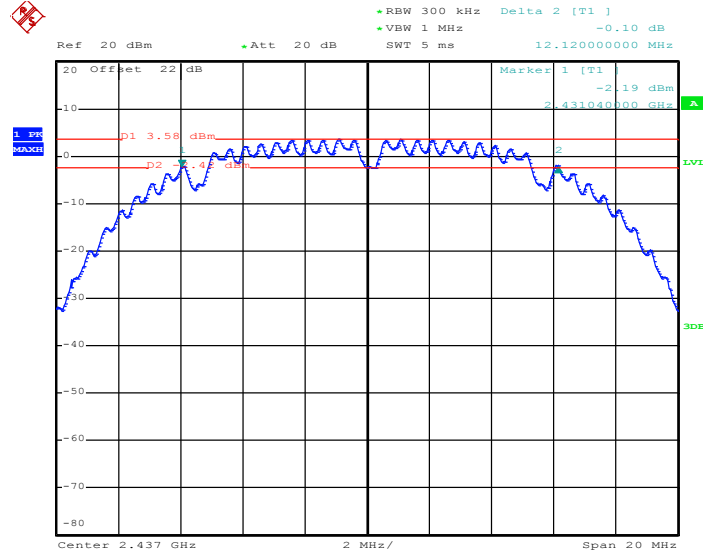

Date: 7.AUG.2012 05:15:16

802.11b – MIMO Ant. 0+1(0)

6 dB Bandwidth Plot on Channel 11

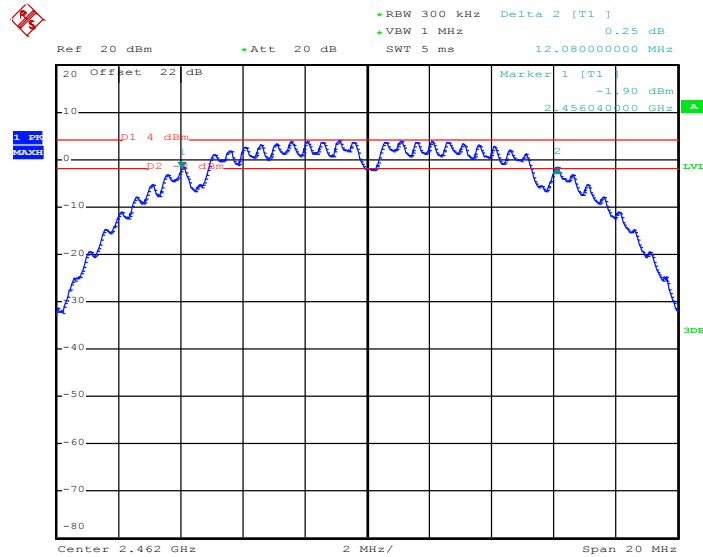

Date: 7.AUG.2012 05:11:14



802.11b – MIMO Ant. 0+1(1)

6 dB Bandwidth Plot on Channel 01

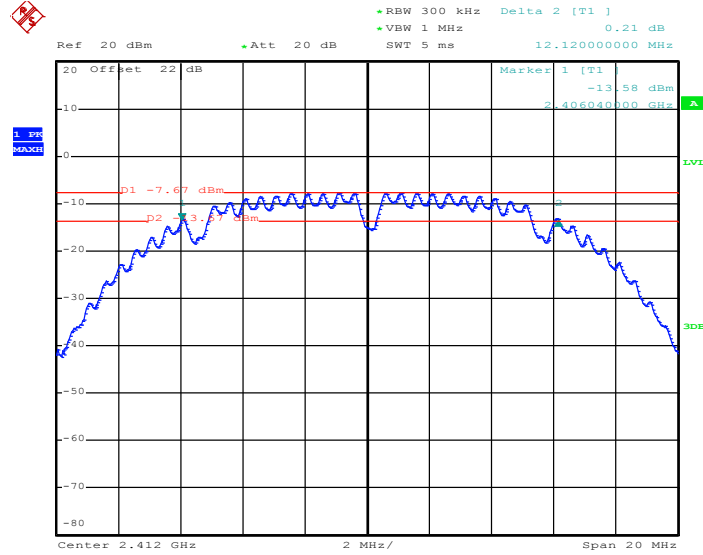

Date: 7.AUG.2012 08:04:04

802.11b – MIMO Ant. 0+1(1)

6 dB Bandwidth Plot on Channel 06

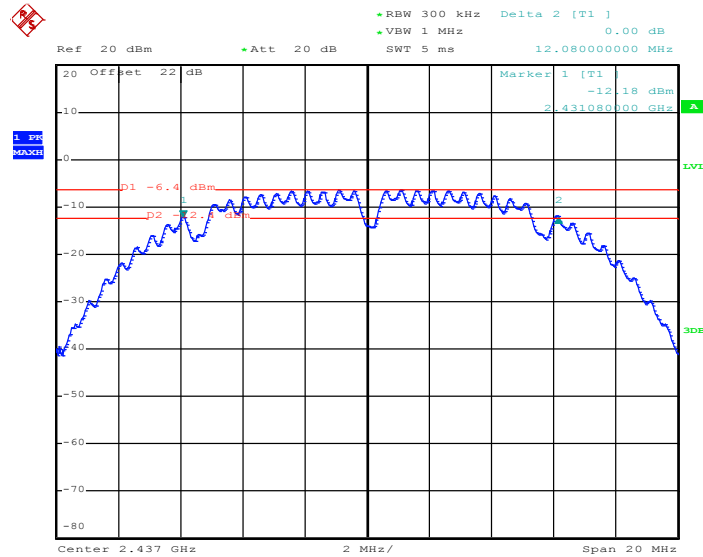

Date: 7.AUG.2012 08:07:07



802.11b – MIMO Ant. 0+1(1)

6 dB Bandwidth Plot on Channel 11

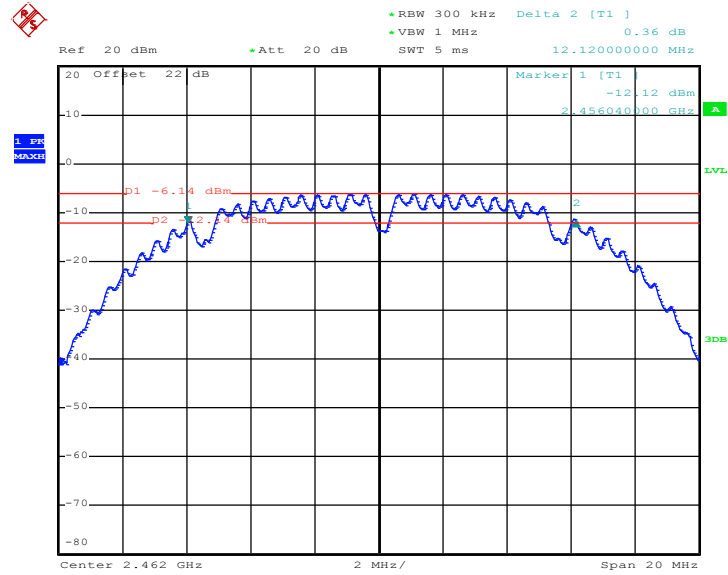

Date: 7.AUG.2012 08:09:42



802.11g – SISO Ant. 0

6 dB Bandwidth Plot on Channel 01

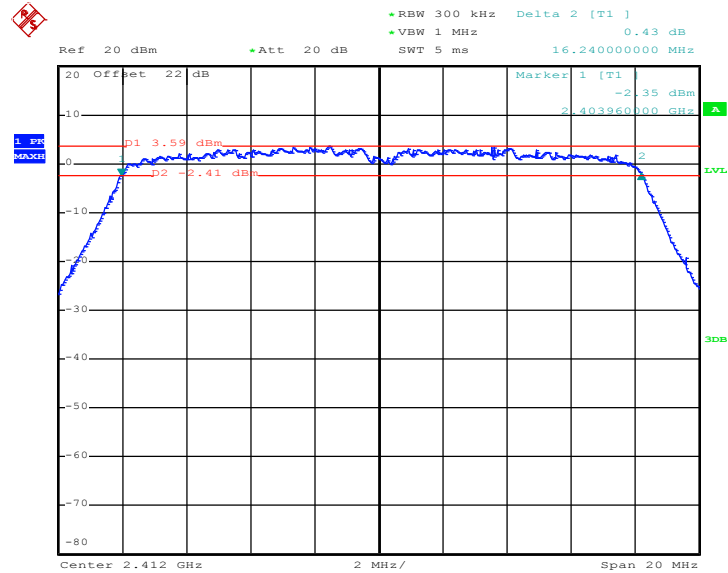

Date: 7.AUG.2012 05:24:27

802.11g – SISO Ant. 0

6 dB Bandwidth Plot on Channel 06

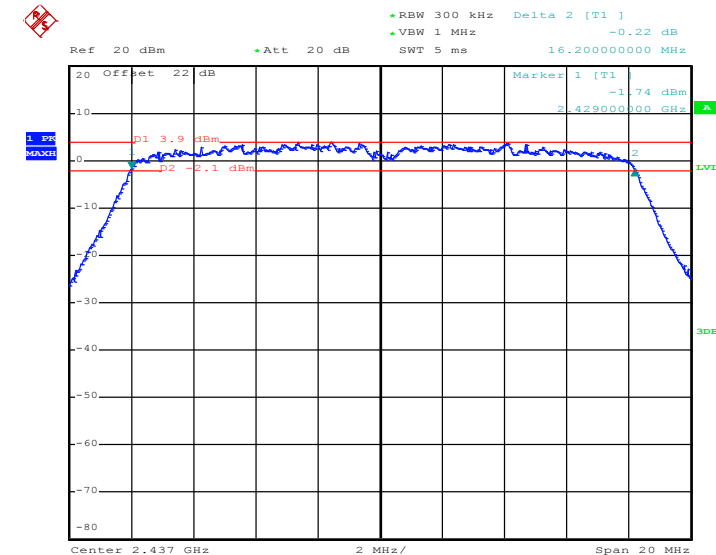

Date: 7.AUG.2012 05:28:15



802.11g – SISO Ant. 0

6 dB Bandwidth Plot Channel 11

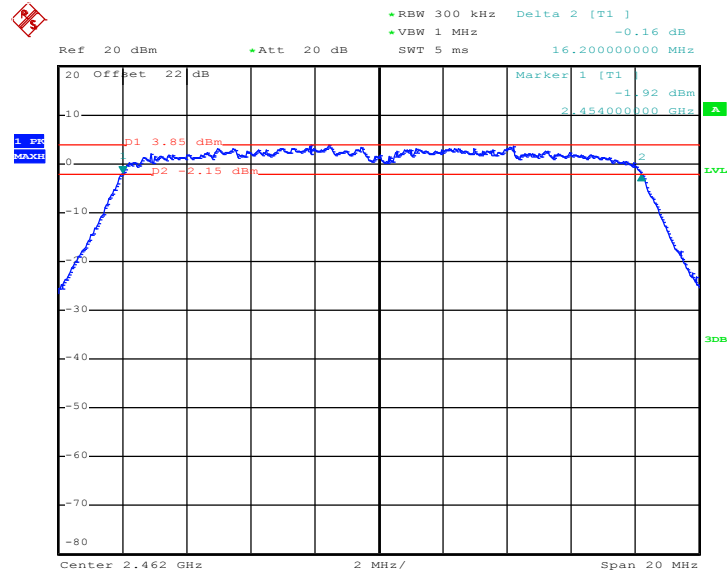

Date: 7.AUG.2012 05:31:23

802.11g – MIMO Ant. 0+1(0)

6 dB Bandwidth Plot on Channel 01

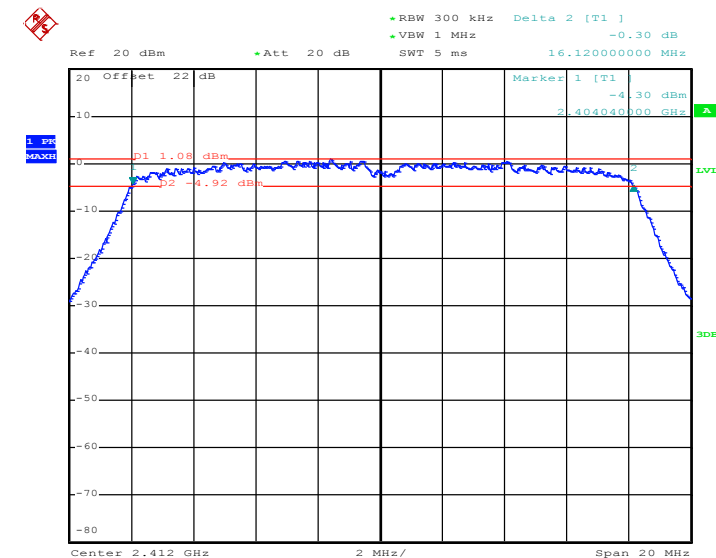

Date: 7.AUG.2012 05:43:15



802.11g – MIMO Ant. 0+1(0)

6 dB Bandwidth Plot on Channel 06

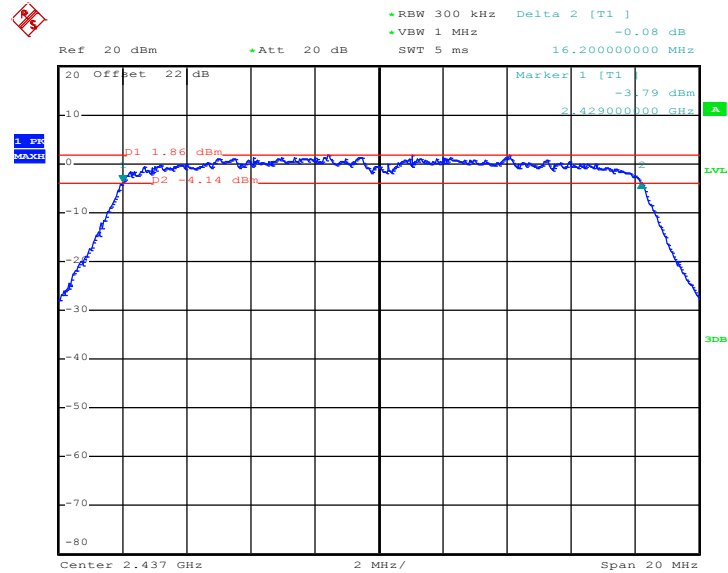

Date: 7.AUG.2012 05:39:39

802.11g – MIMO Ant. 0+1(0)

6 dB Bandwidth Plot on Channel 11

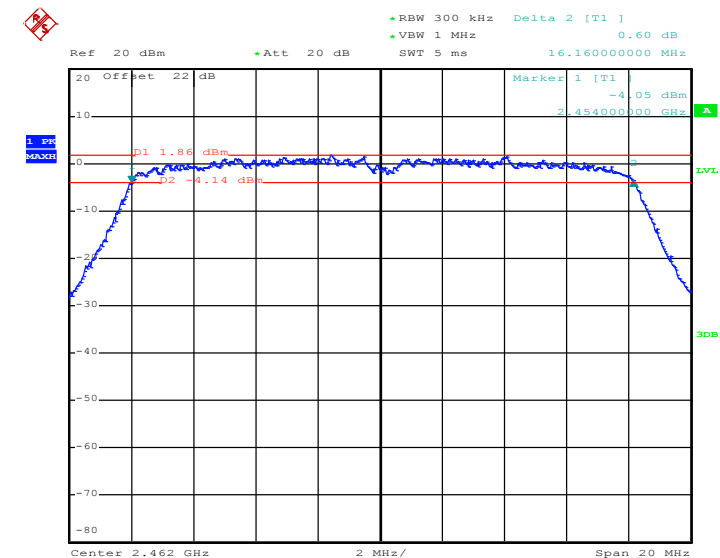

Date: 7.AUG.2012 05:35:22



802.11g – MIMO Ant. 0+1(1)

6 dB Bandwidth Plot on Channel 01

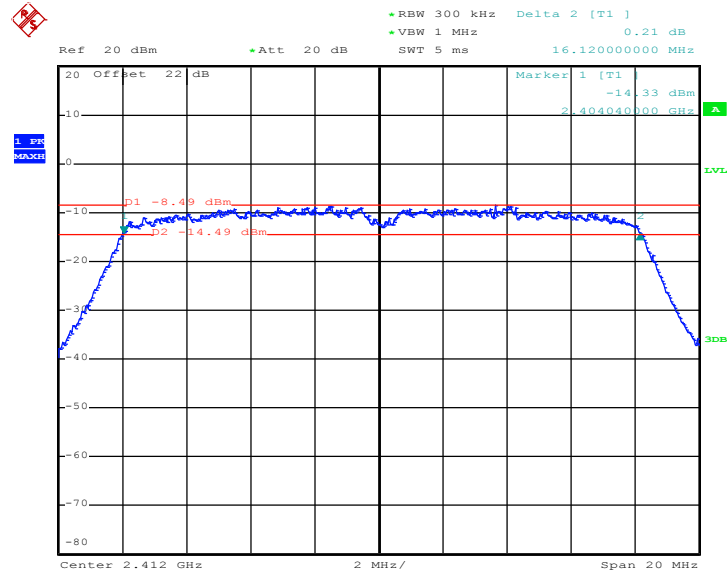

Date: 7.AUG.2012 08:00:31

802.11g – MIMO Ant. 0+1(1)

6 dB Bandwidth Plot on Channel 06

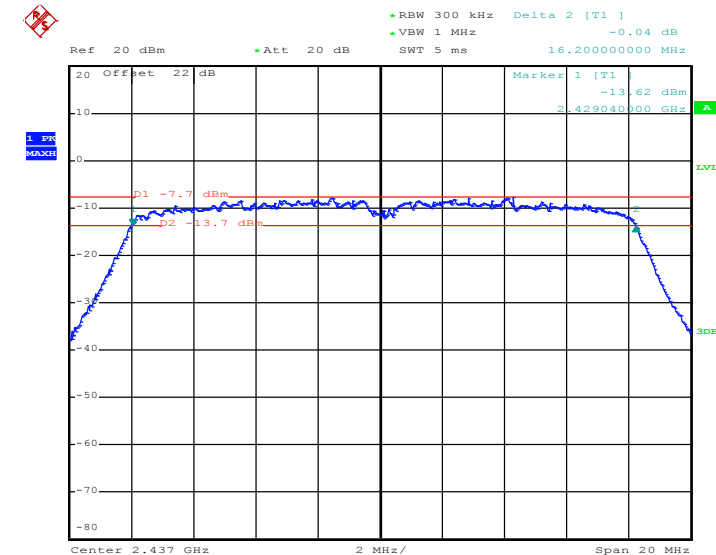

Date: 7.AUG.2012 07:57:37



802.11g – MIMO Ant. 0+1(1)

6 dB Bandwidth Plot on Channel 11

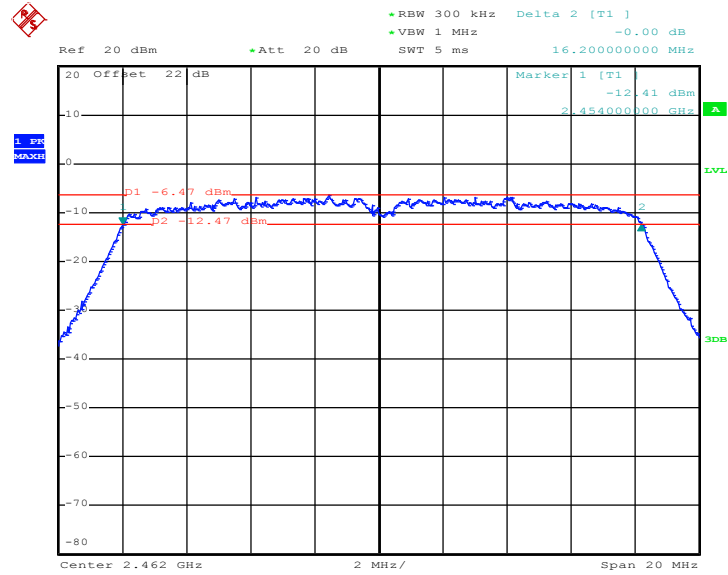

Date: 7.AUG.2012 07:51:28



802.11n HT-20 – SISO Ant. 0

6 dB Bandwidth Plot on Channel 01

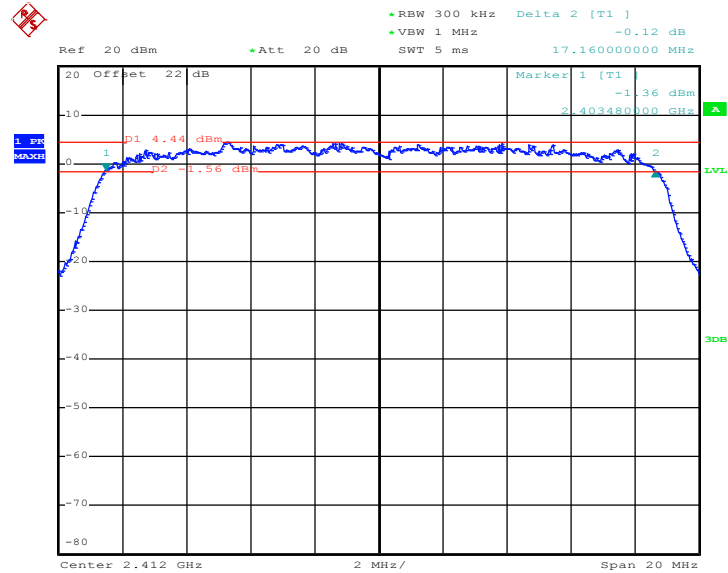

Date: 7.AUG.2012 05:49:33

802.11n HT-20 – SISO Ant. 0

6 dB Bandwidth Plot on Channel 06

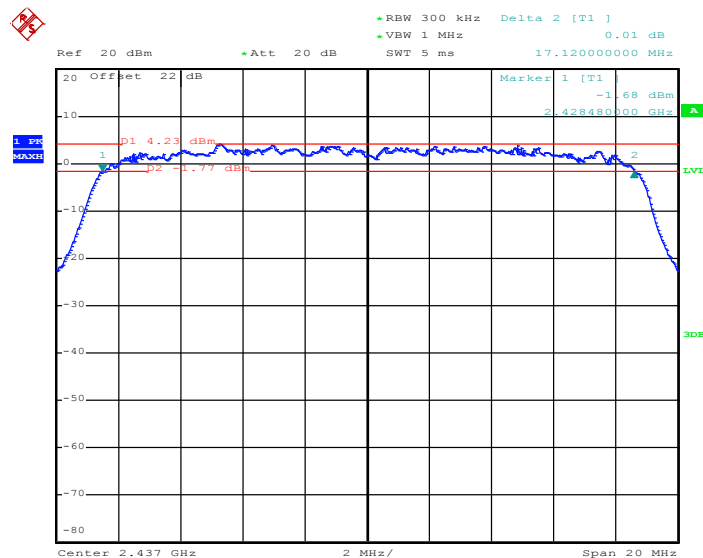

Date: 7.AUG.2012 05:55:19

802.11n HT-20 – SISO Ant. 0

6 dB Bandwidth Plot on Channel 11

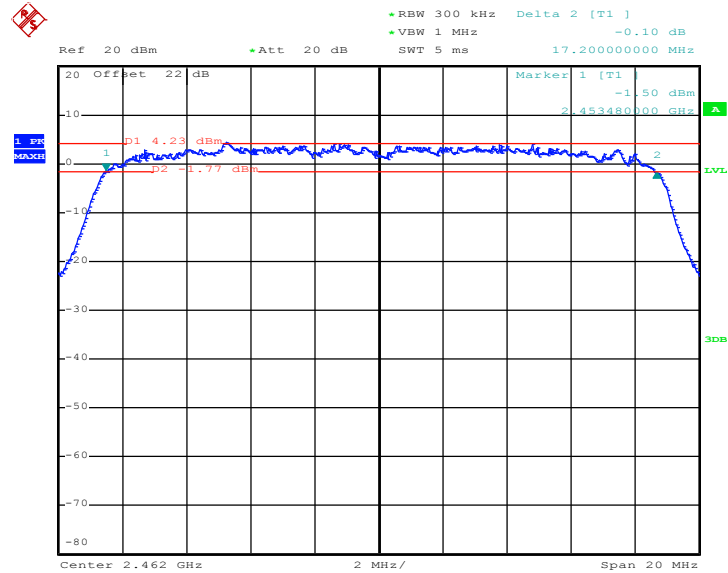

Date: 7.AUG.2012 05:58:52

802.11n HT-20 – MIMO Ant. 0+1(0)

6 dB Bandwidth Plot on Channel 01

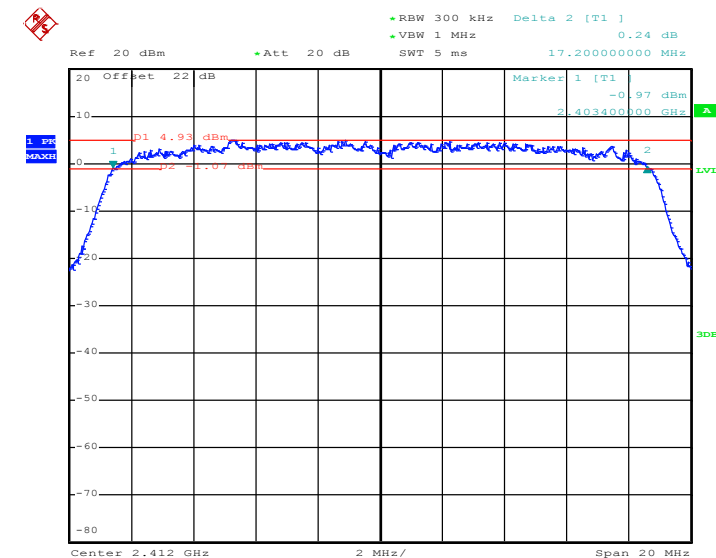

Date: 7.AUG.2012 06:10:01



802.11n HT-20 – MIMO Ant. 0+1(0)

6 dB Bandwidth Plot on Channel 06

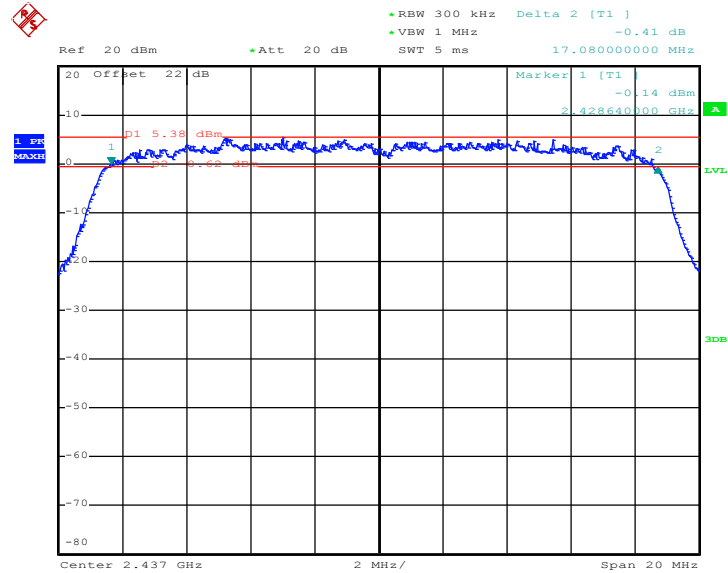

Date: 7.AUG.2012 06:06:39

802.11n HT-20 – MIMO Ant. 0+1(0)

6 dB Bandwidth Plot on Channel 11

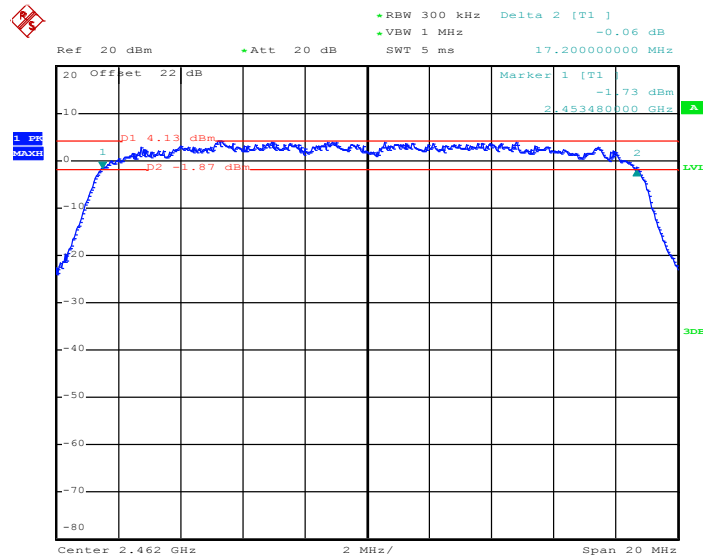

Date: 7.AUG.2012 06:03:08



802.11n HT-20 – MIMO Ant. 0+1(1)

6 dB Bandwidth Plot on Channel 01

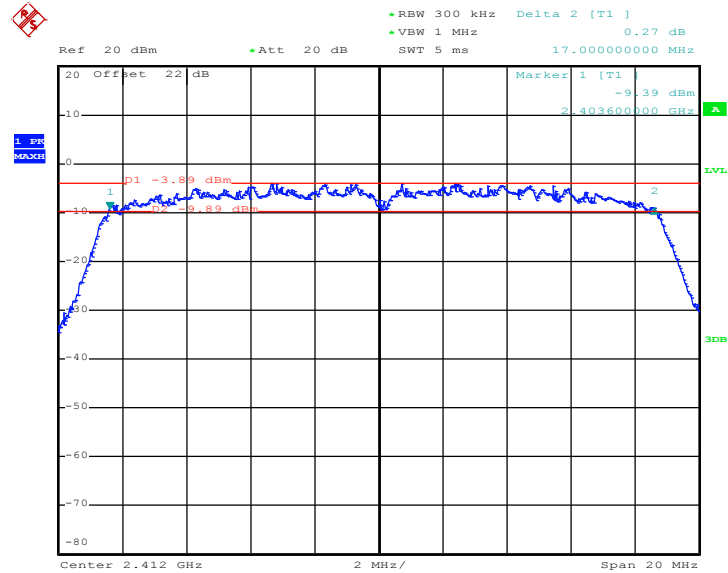

Date: 7.AUG.2012 07:38:25

802.11n HT-20 – MIMO Ant. 0+1(1)

6 dB Bandwidth Plot on Channel 06

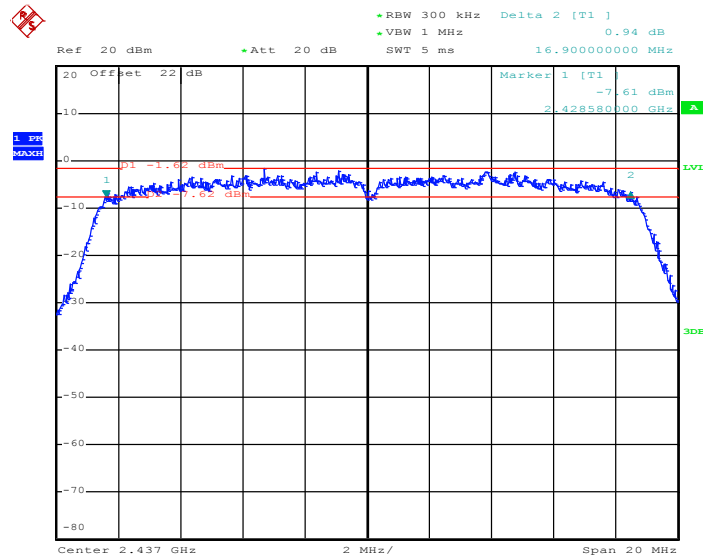

Date: 7.AUG.2012 07:42:34



802.11n HT-20 – MIMO Ant. 0+1(1)

6 dB Bandwidth Plot on Channel 11

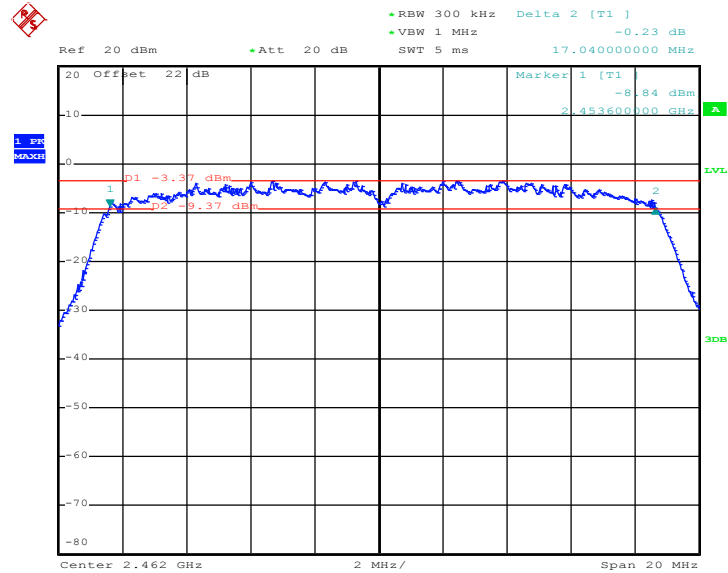

Date: 7.AUG.2012 07:46:07



802.11n HT-40 – SISO Ant. 0

6 dB Bandwidth Plot on Channel 03

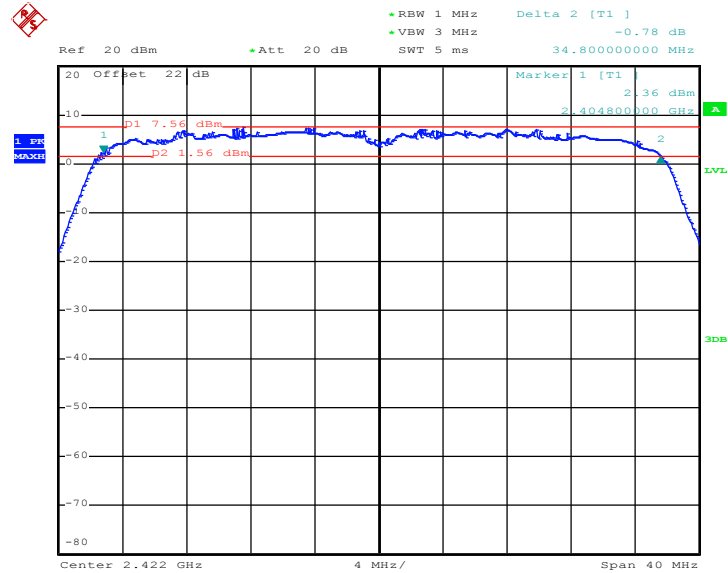

Date: 7.AUG.2012 06:27:14

802.11n HT-40 – SISO Ant. 0

6 dB Bandwidth Plot on Channel 06

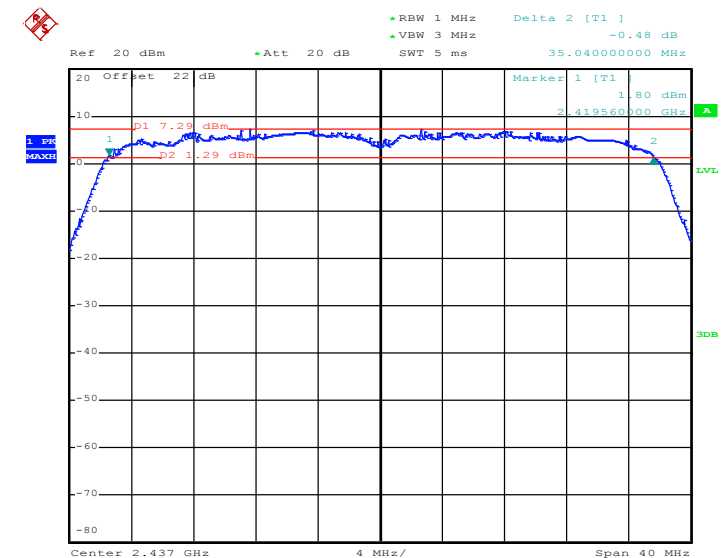

Date: 7.AUG.2012 06:50:39



802.11n HT-40 – SISO Ant. 0

6 dB Bandwidth Plot on Channel 09

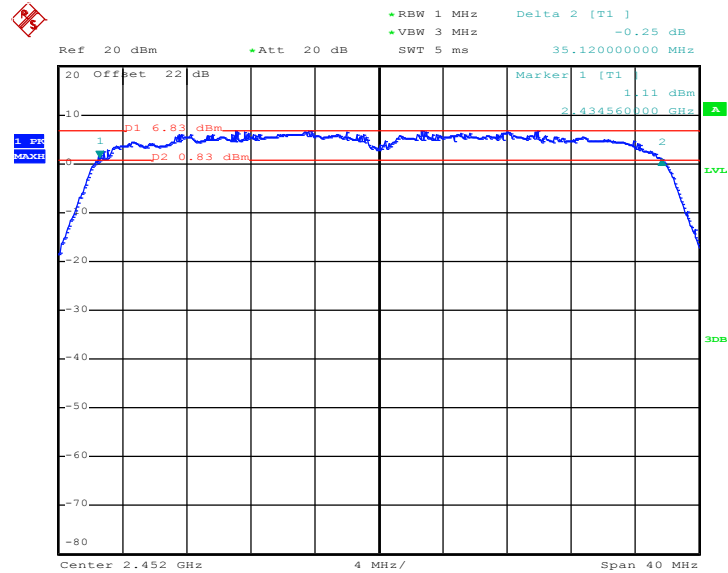

Date: 7.AUG.2012 06:54:36

802.11n HT-40 – MIMO Ant. 0+1(0)

6 dB Bandwidth Plot on Channel 03

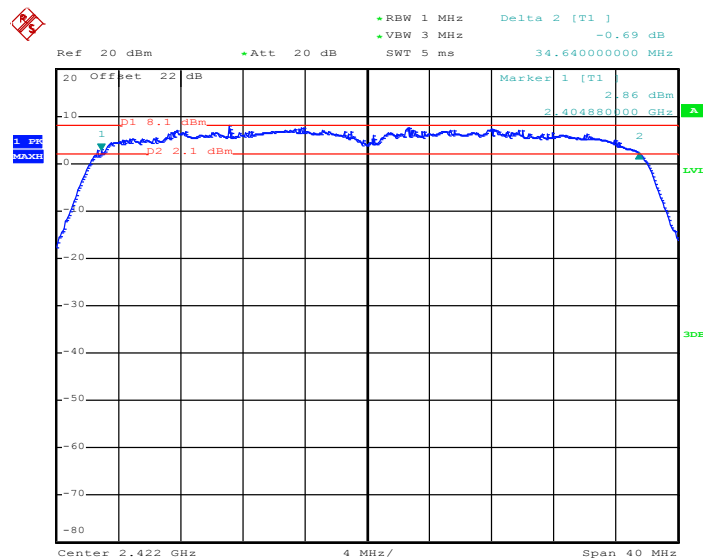

Date: 7.AUG.2012 07:08:04

802.11n HT-40 – MIMO Ant. 0+1(0)

6 dB Bandwidth Plot on Channel 06

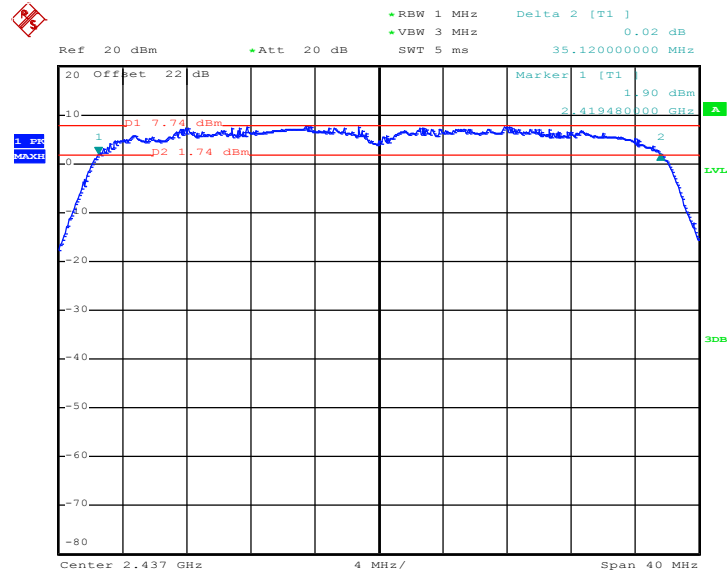

Date: 7.AUG.2012 07:04:33

802.11n HT-40 – MIMO Ant. 0+1(0)

6 dB Bandwidth Plot on Channel 09

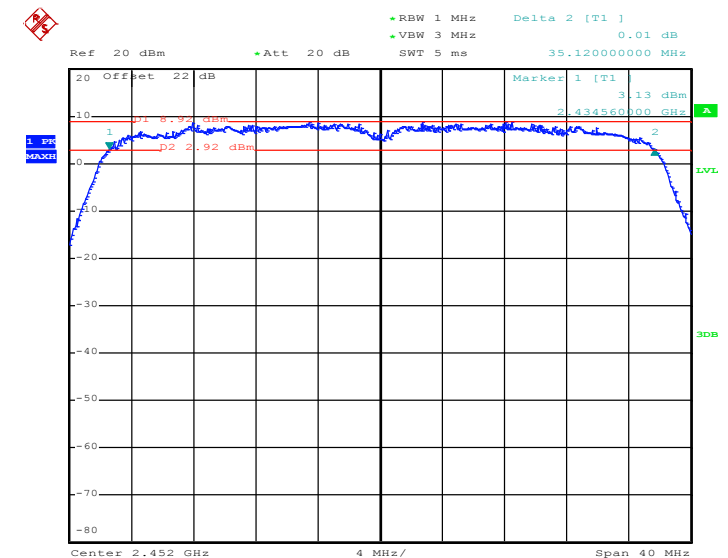

Date: 7.AUG.2012 06:59:29



802.11n HT-40 – MIMO Ant. 0+1(1)

6 dB Bandwidth Plot on Channel 03

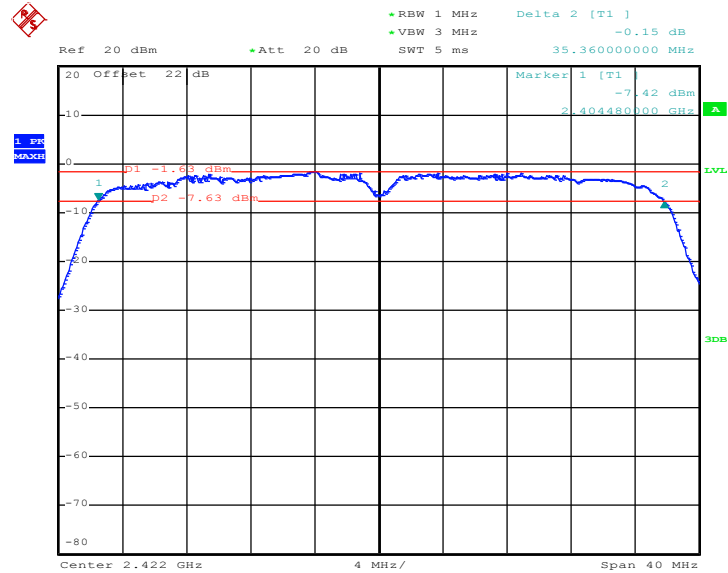

Date: 7.AUG.2012 07:12:51

802.11n HT-40 – MIMO Ant. 0+1(1)

6 dB Bandwidth Plot on Channel 06

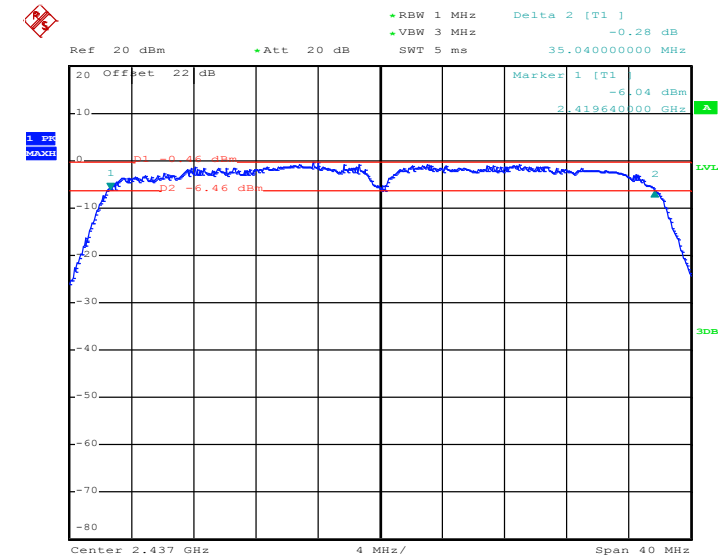

Date: 7.AUG.2012 07:19:41



802.11n HT-40 – MIMO Ant. 0+1(1)

6 dB Bandwidth Plot on Channel 09

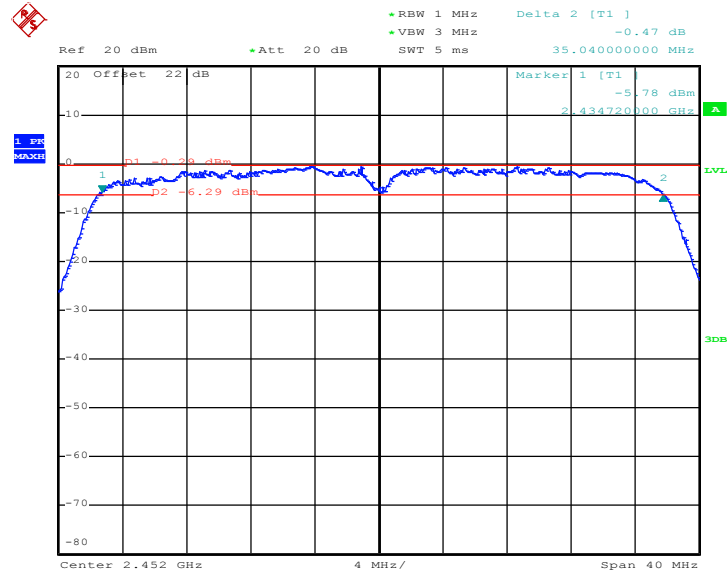

Date: 7.AUG.2012 07:28:43



3.1.8 Test Result of 99% Bandwidth Plots

802.11b – SISO Ant. 0

99% Occupied Bandwidth Plot on Channel 01

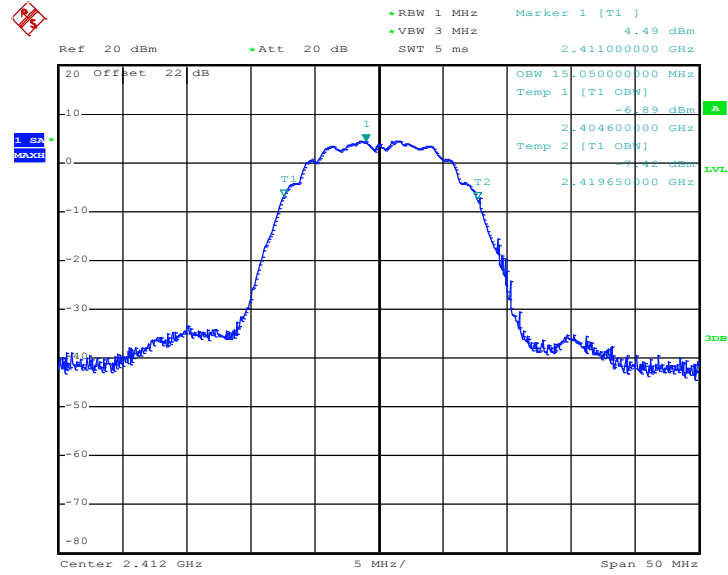

Date: 7.AUG.2012 04:56:55

802.11b – SISO Ant. 0

99% Occupied Bandwidth Plot on Channel 06

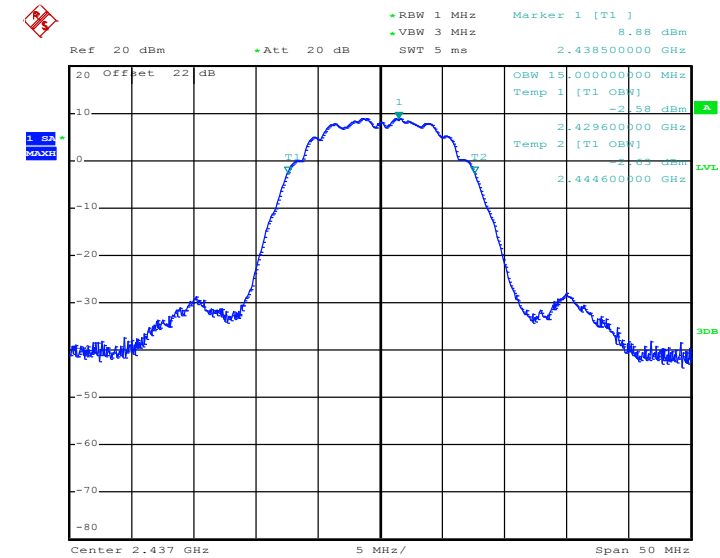

Date: 7.AUG.2012 05:01:23



802.11b – SISO Ant. 0

99% Occupied Bandwidth Plot on Channel 11

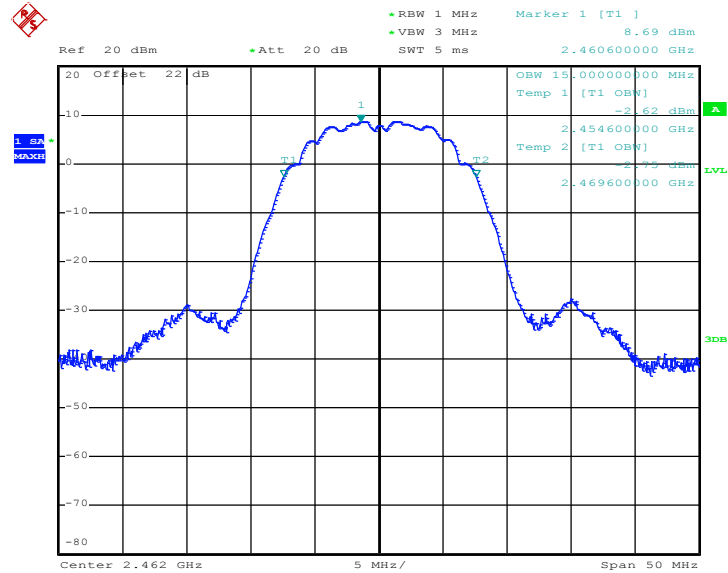

Date: 7.AUG.2012 05:04:34

802.11b – MIMO Ant. 0+1(0)

99% Occupied Bandwidth Plot on Channel 01

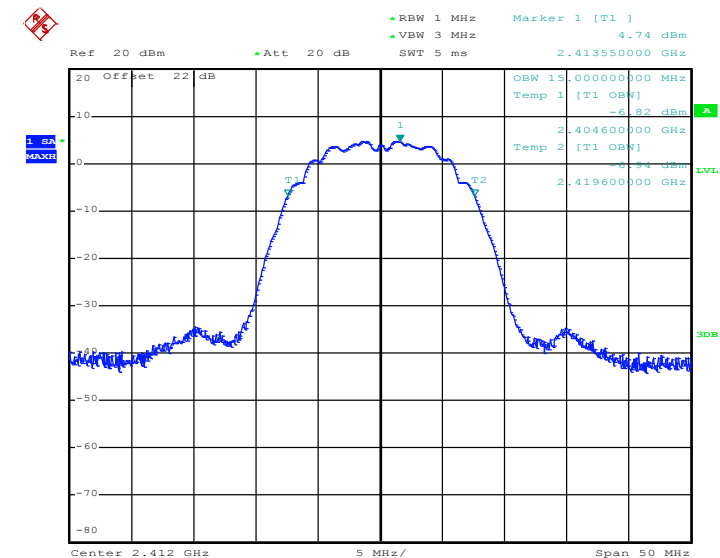

Date: 7.AUG.2012 05:18:12



802.11b – MIMO Ant. 0+1(0)

99% Occupied Bandwidth Plot on Channel 06

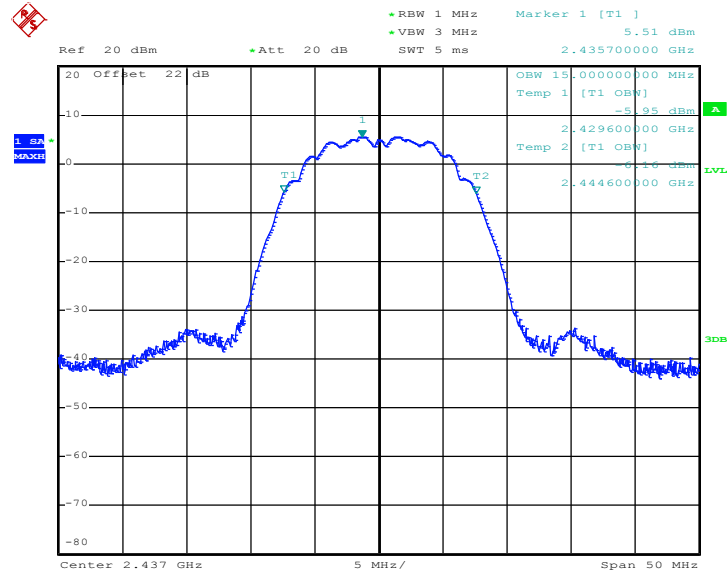

Date: 7.AUG.2012 05:14:43

802.11b – MIMO Ant. 0+1(0)

99% Occupied Bandwidth Plot on Channel 11

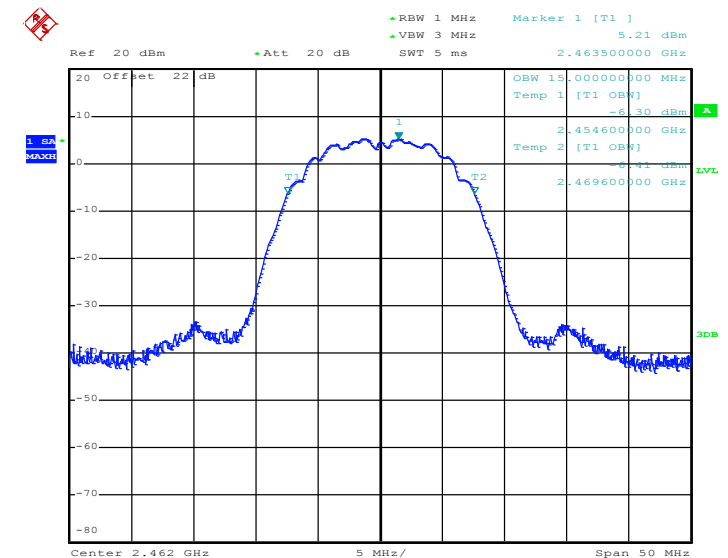

Date: 7.AUG.2012 05:10:47



802.11b – MIMO Ant. 0+1(1)

99% Occupied Bandwidth Plot on Channel 01

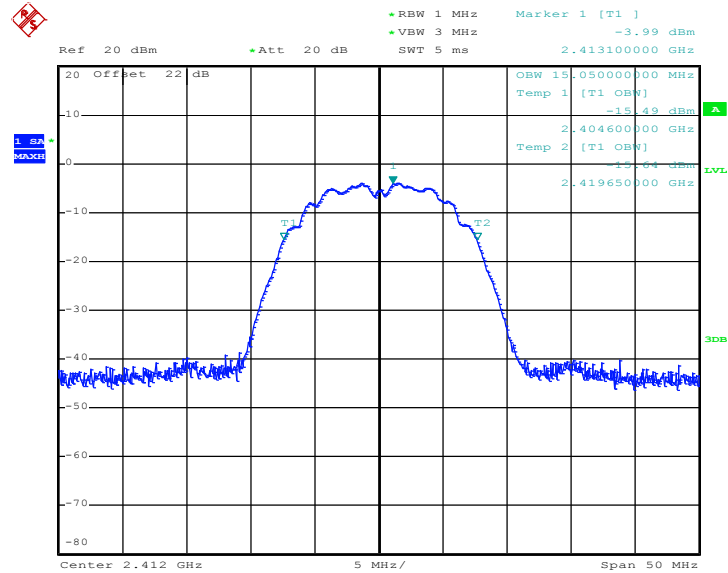

Date: 7.AUG.2012 08:02:57

802.11b – MIMO Ant. 0+1(1)

99% Occupied Bandwidth Plot on Channel 06

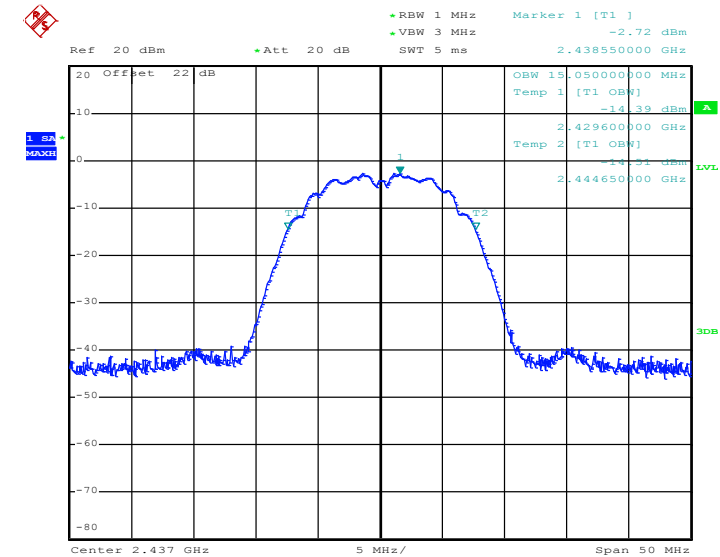

Date: 7.AUG.2012 08:05:37



802.11b – MIMO Ant. 0+1(1)

99% Occupied Bandwidth Plot on Channel 11

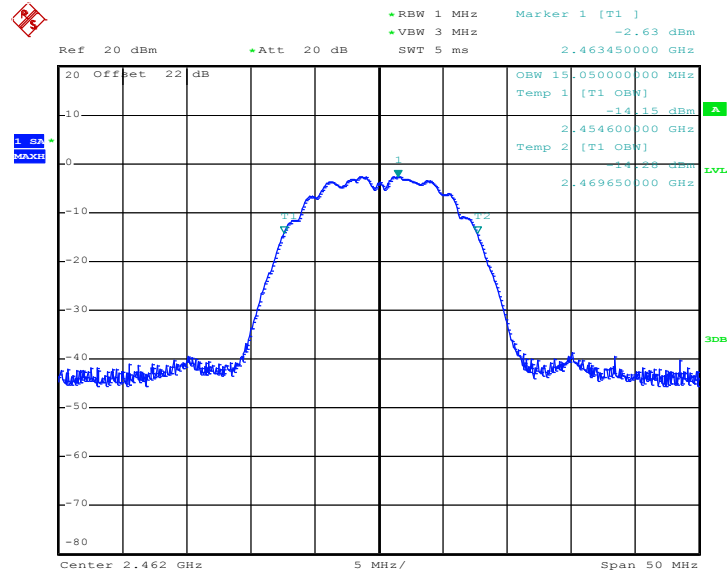

Date: 7.AUG.2012 08:08:26



802.11g – SISO Ant. 0

99% Occupied Bandwidth Plot on Channel 01

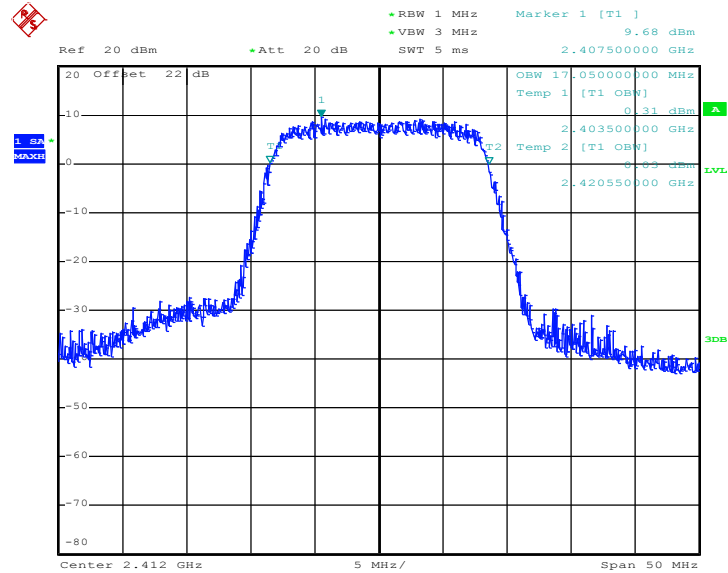

Date: 7.AUG.2012 05:23:40

802.11g – SISO Ant. 0

99% Occupied Bandwidth Plot on Channel 06

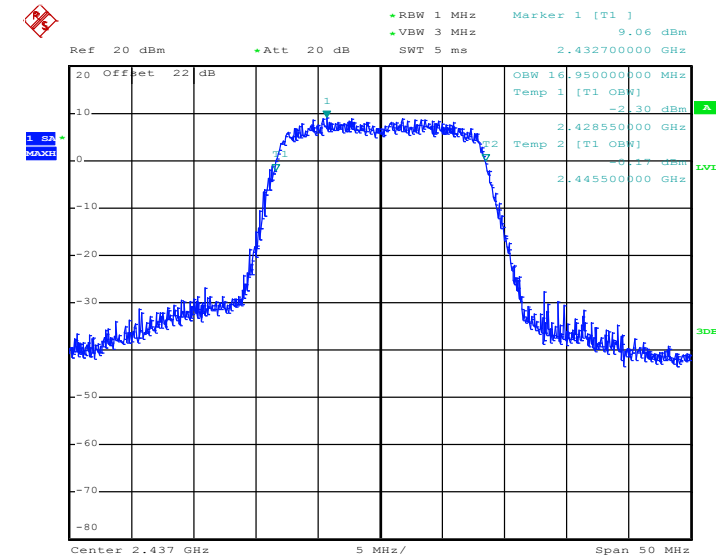

Date: 7.AUG.2012 05:26:58



802.11g – SISO Ant. 0

99% Occupied Bandwidth Plot Channel 11

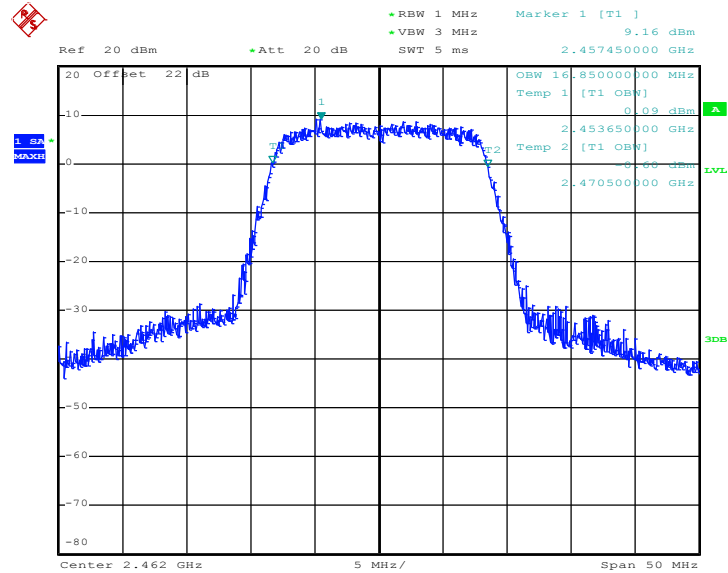

Date: 7.AUG.2012 05:30:27

802.11g – MIMO Ant. 0+1(0)

99% Occupied Bandwidth Plot on Channel 01

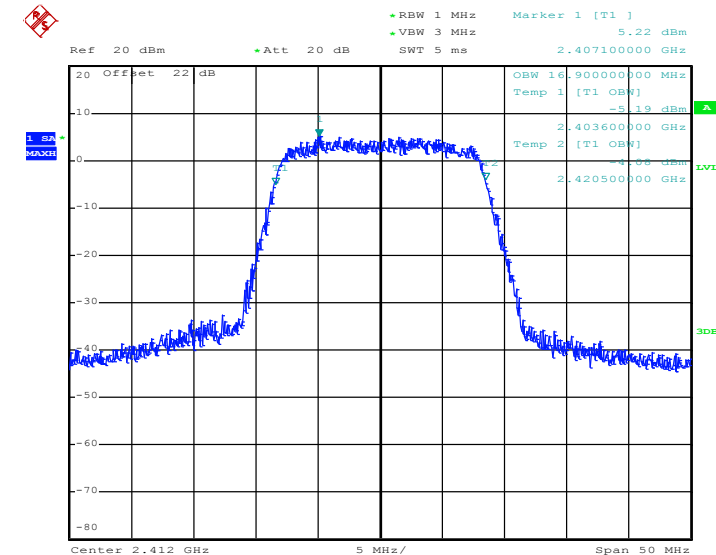

Date: 7.AUG.2012 05:42:13



802.11g – MIMO Ant. 0+1(0)

99% Occupied Bandwidth Plot on Channel 06

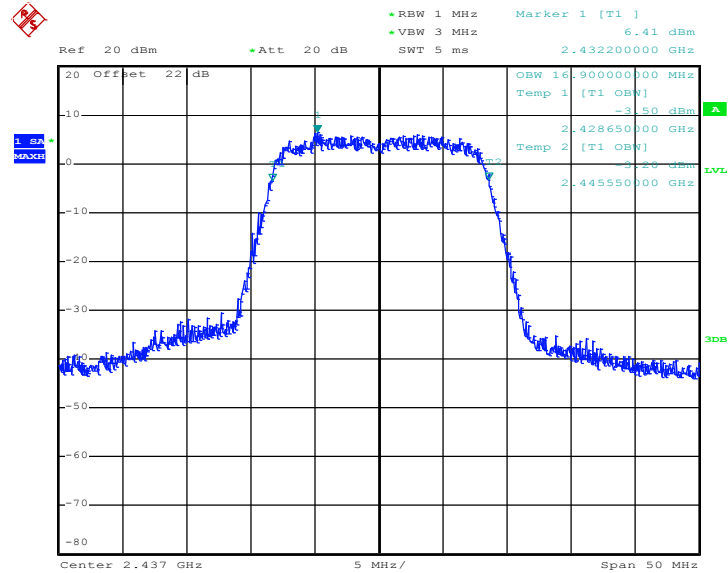

Date: 7.AUG.2012 05:38:30

802.11g – MIMO Ant. 0+1(0)

99% Occupied Bandwidth Plot on Channel 11

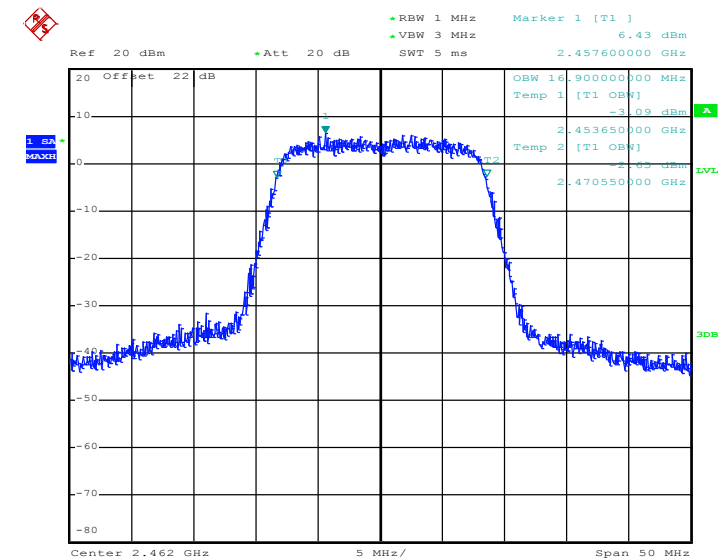

Date: 7.AUG.2012 05:34:59



802.11g – MIMO Ant. 0+1(1)

99% Occupied Bandwidth Plot on Channel 01

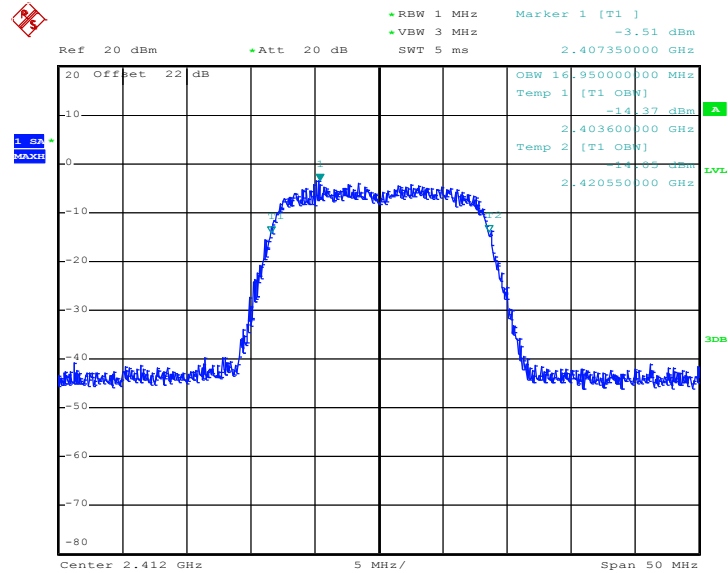

Date: 7.AUG.2012 07:59:19

802.11g – MIMO Ant. 0+1(1)

99% Occupied Bandwidth Plot on Channel 06

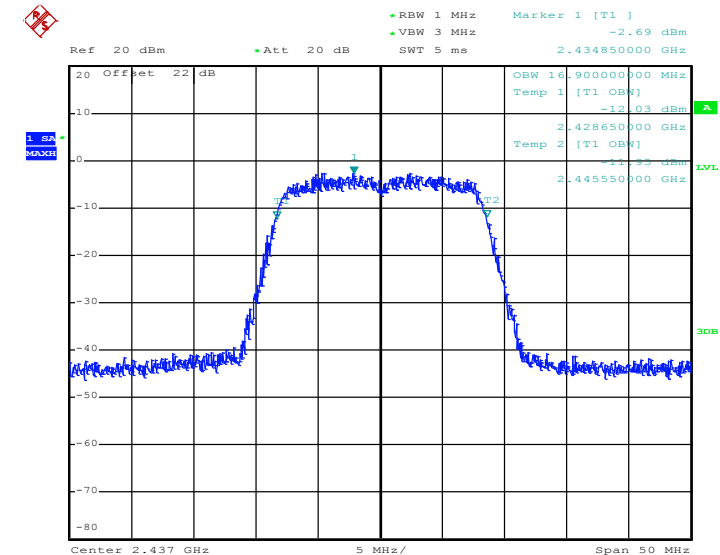

Date: 7.AUG.2012 07:56:12



802.11g – MIMO Ant. 0+1(1)

99% Occupied Bandwidth Plot on Channel 11

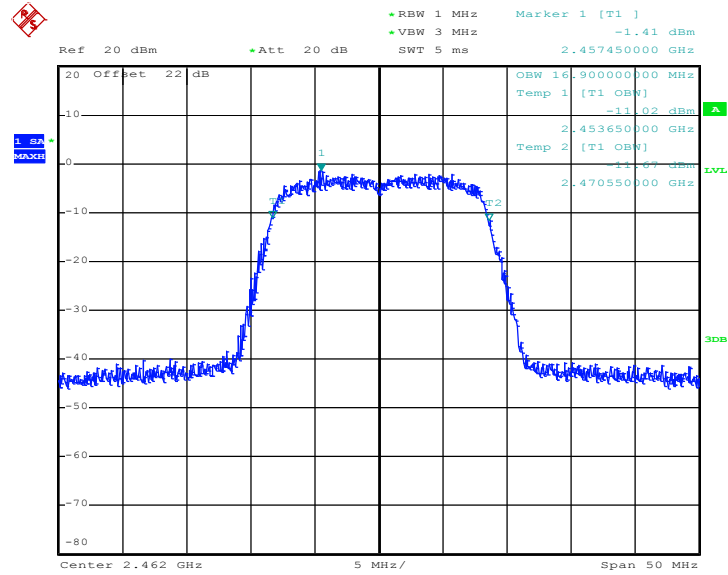

Date: 7.AUG.2012 07:51:29



802.11n HT-20 – SISO Ant. 0

99% Occupied Bandwidth Plot on Channel 01

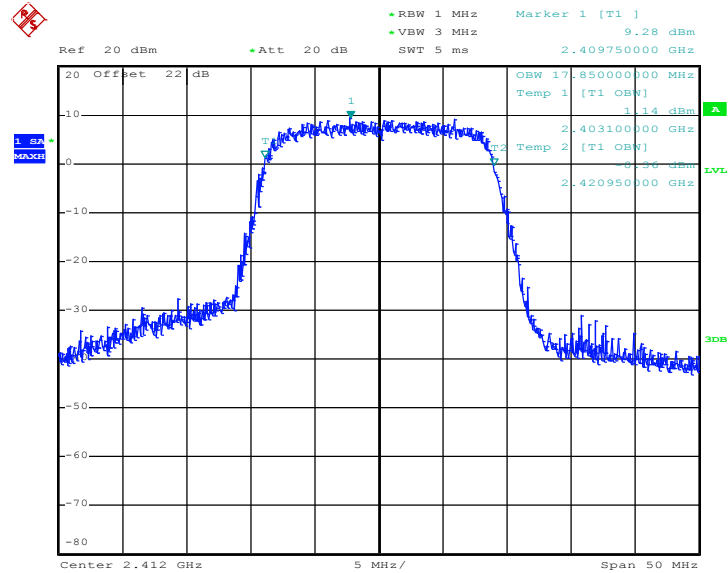

Date: 7.AUG.2012 05:49:33

802.11n HT-20 – SISO Ant. 0

99% Occupied Bandwidth Plot on Channel 06

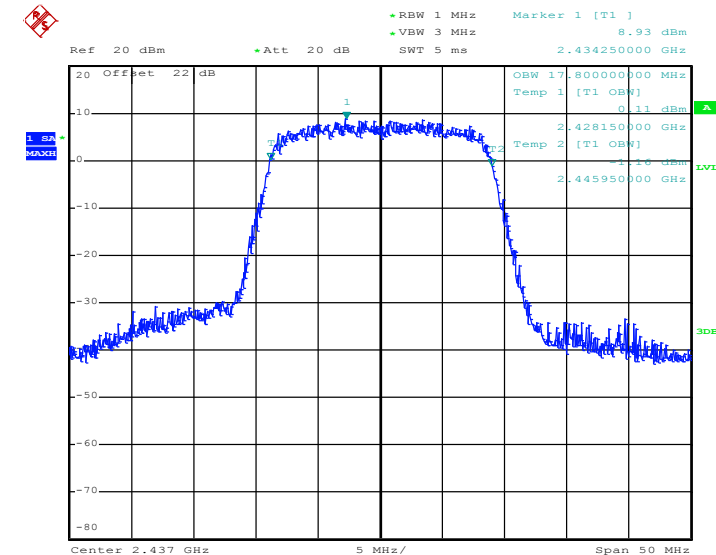

Date: 7.AUG.2012 05:54:07



802.11n HT-20 – SISO Ant. 0

99% Occupied Bandwidth Plot on Channel 11

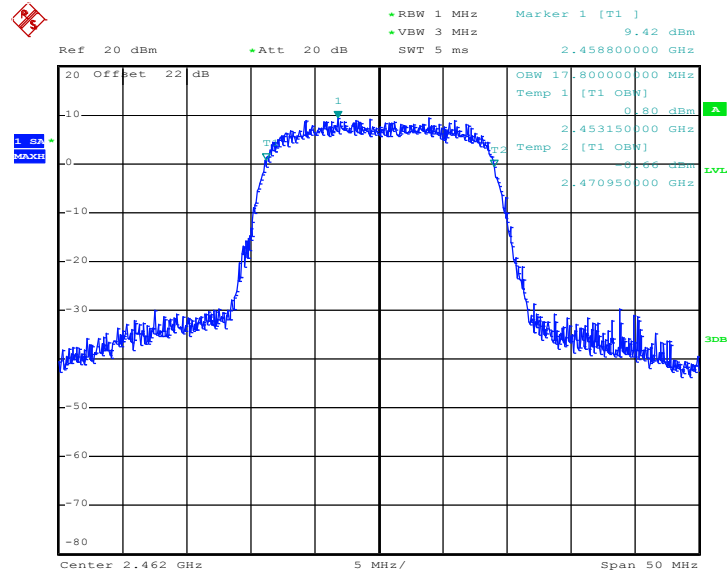

Date: 7.AUG.2012 05:58:04

802.11n HT-20 – MIMO Ant. 0+1(0)

99% Occupied Bandwidth Plot on Channel 01

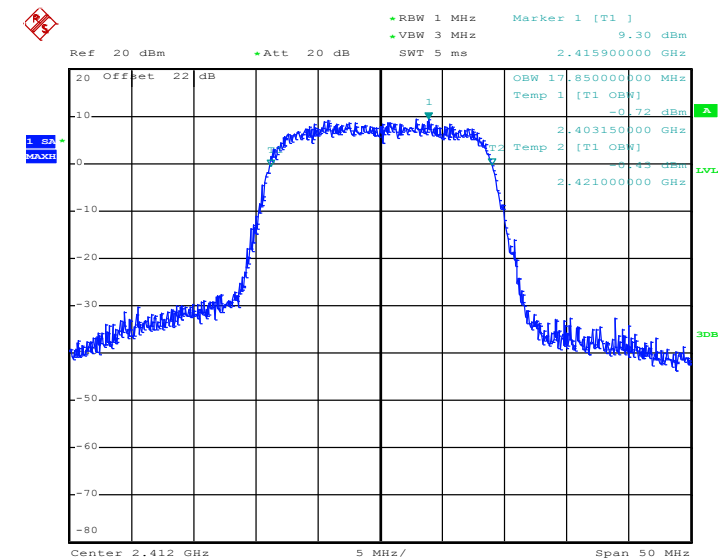

Date: 7.AUG.2012 06:08:59



802.11n HT-20 – MIMO Ant. 0+1(0)

99% Occupied Bandwidth Plot on Channel 06

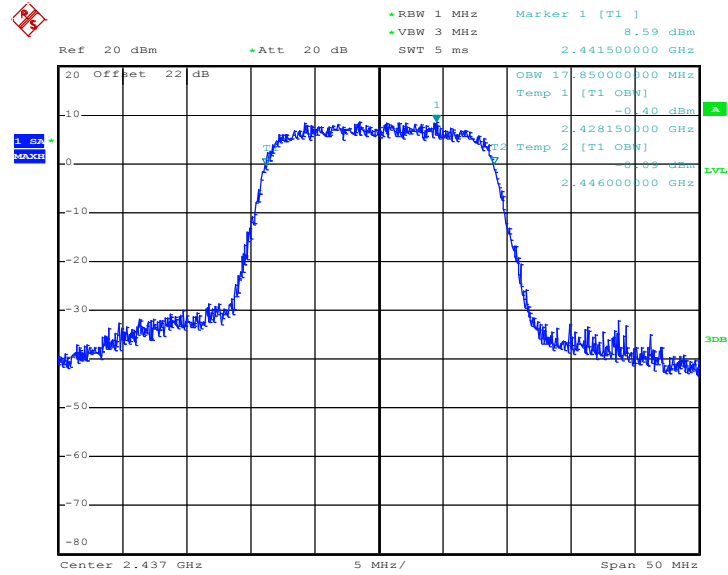

Date: 7.AUG.2012 06:05:28

802.11n HT-20 – MIMO Ant. 0+1(0)

99% Occupied Bandwidth Plot on Channel 11

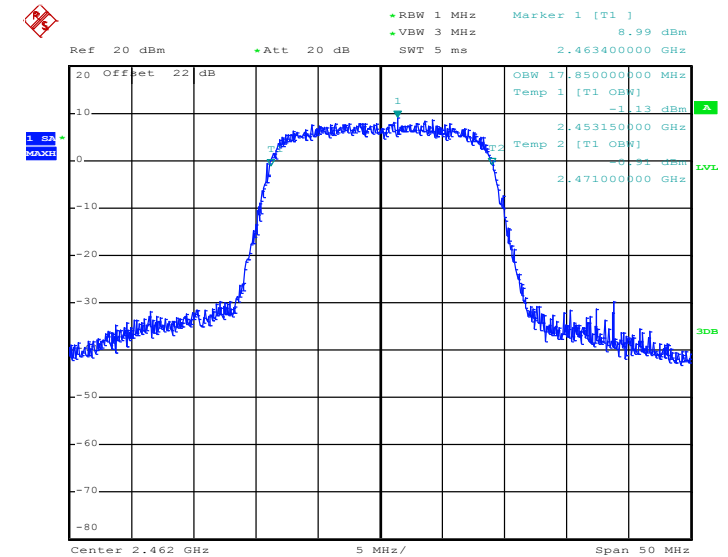

Date: 7.AUG.2012 06:02:02



802.11n HT-20 – MIMO Ant. 0+1(1)

99% Occupied Bandwidth Plot on Channel 01

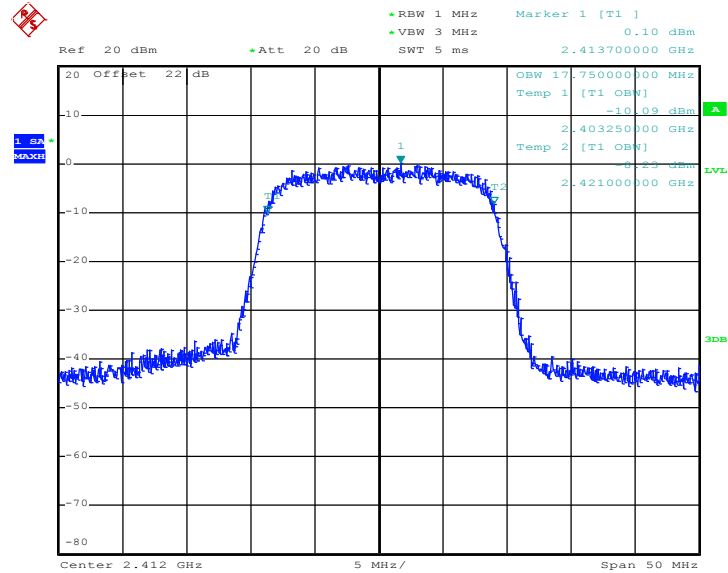

Date: 7.AUG.2012 07:37:18

802.11n HT-20 – MIMO Ant. 0+1(1)

99% Occupied Bandwidth Plot on Channel 06

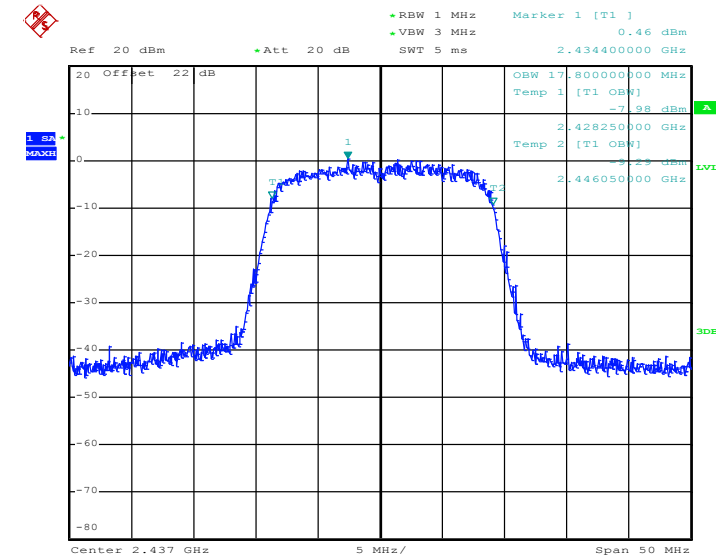

Date: 7.AUG.2012 07:41:07



802.11n HT-20 – MIMO Ant. 0+1(1)

99% Occupied Bandwidth Plot on Channel 11

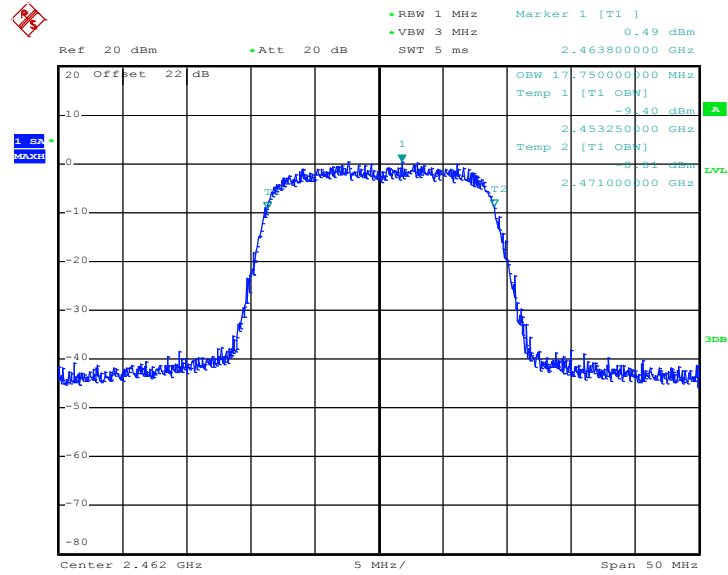

Date: 7.AUG.2012 07:46:11



802.11n HT-40 – SISO Ant. 0

99% Occupied Bandwidth Plot on Channel 03

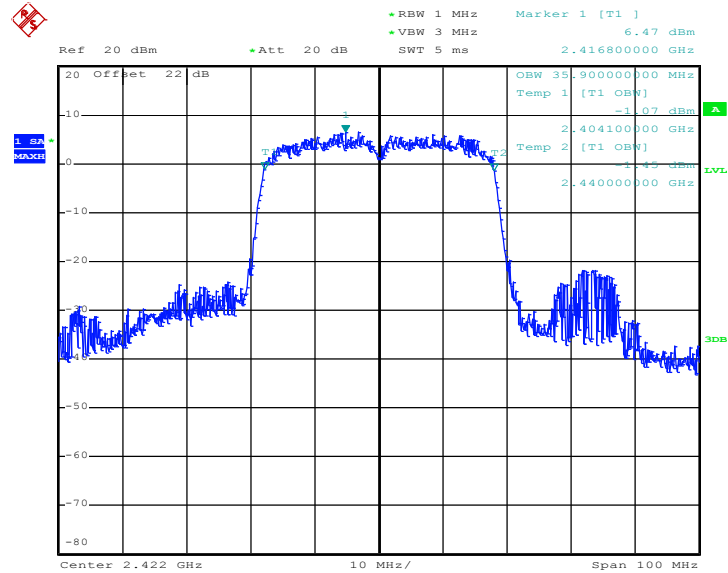

Date: 7.AUG.2012 06:46:08

802.11n HT-40 – SISO Ant. 0

99% Occupied Bandwidth Plot on Channel 06

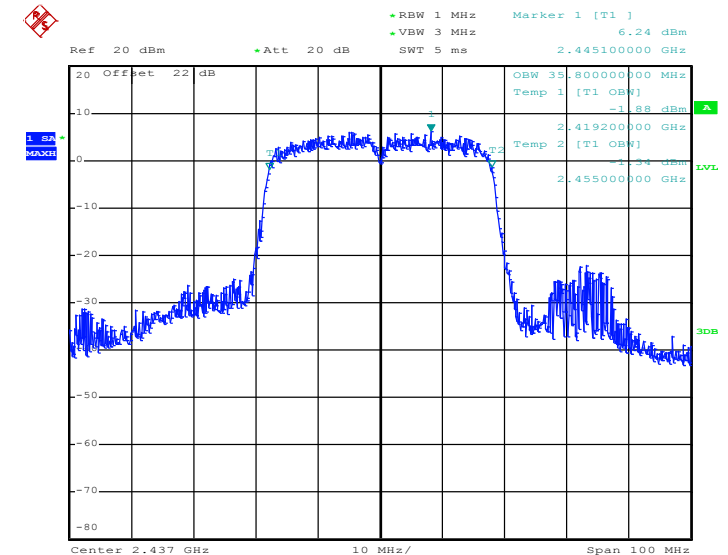

Date: 7.AUG.2012 06:50:03



802.11n HT-40 – SISO Ant. 0

99% Occupied Bandwidth Plot on Channel 09

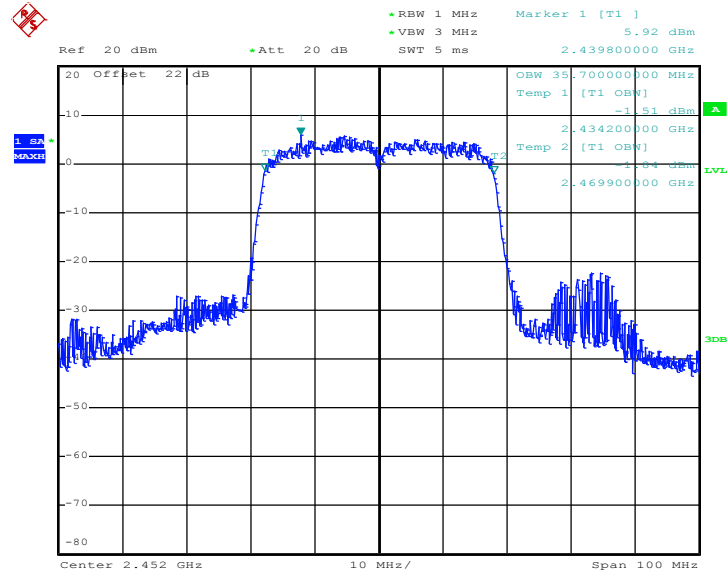

Date: 7.AUG.2012 06:54:05

802.11n HT-40 –MIMO Ant. 0+1(0)

99% Occupied Bandwidth Plot on Channel 03

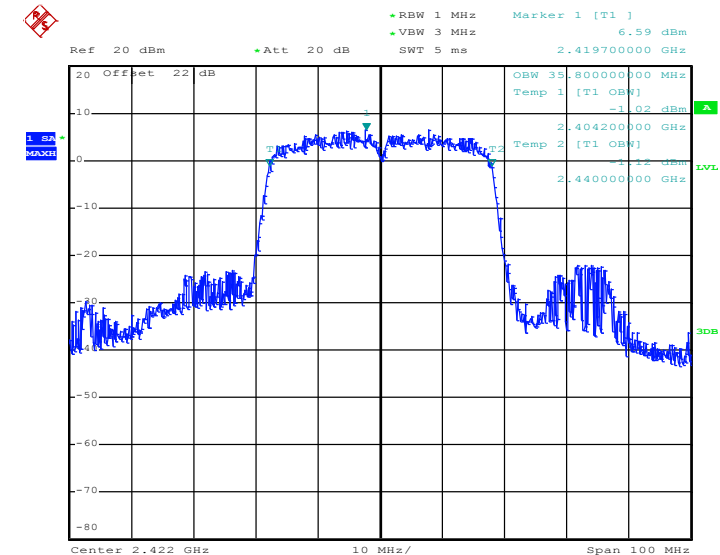

Date: 7.AUG.2012 07:06:55



802.11n HT-40 –MIMO Ant. 0+1(0)

99% Occupied Bandwidth Plot on Channel 06

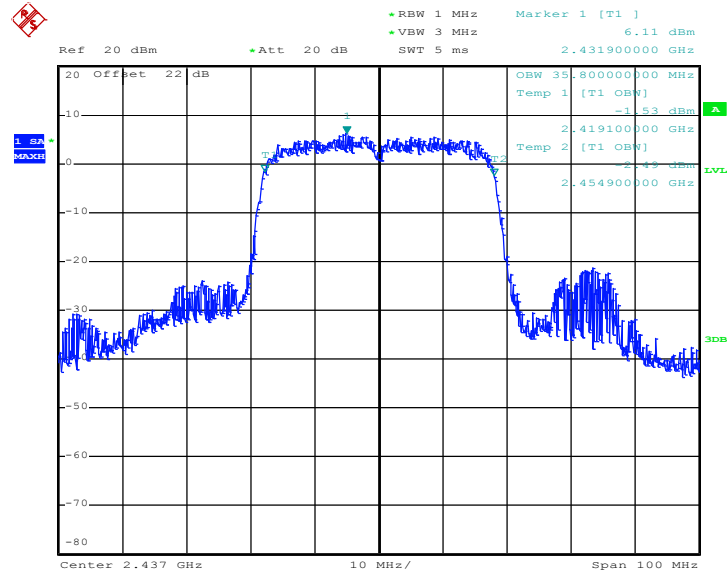

Date: 7.AUG.2012 07:03:11

802.11n HT-40 –MIMO Ant. 0+1(0)

99% Occupied Bandwidth Plot on Channel 09

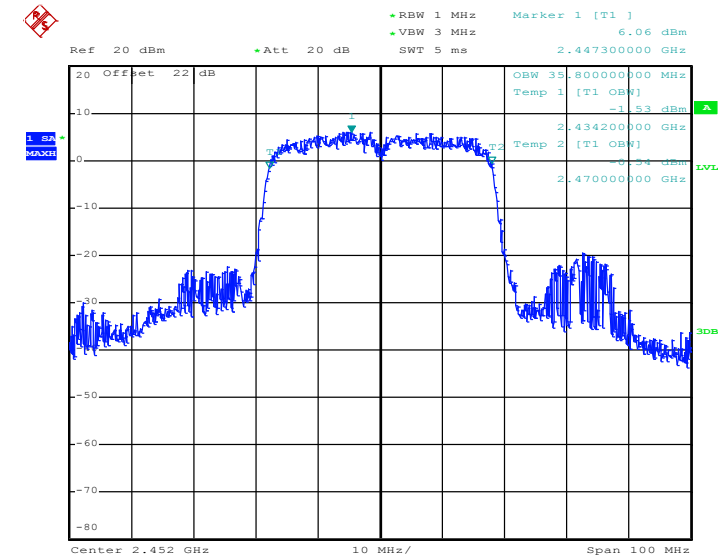

Date: 7.AUG.2012 06:59:52



802.11n HT-40 –MIMO Ant. 0+1(1)

99% Occupied Bandwidth Plot on Channel 03

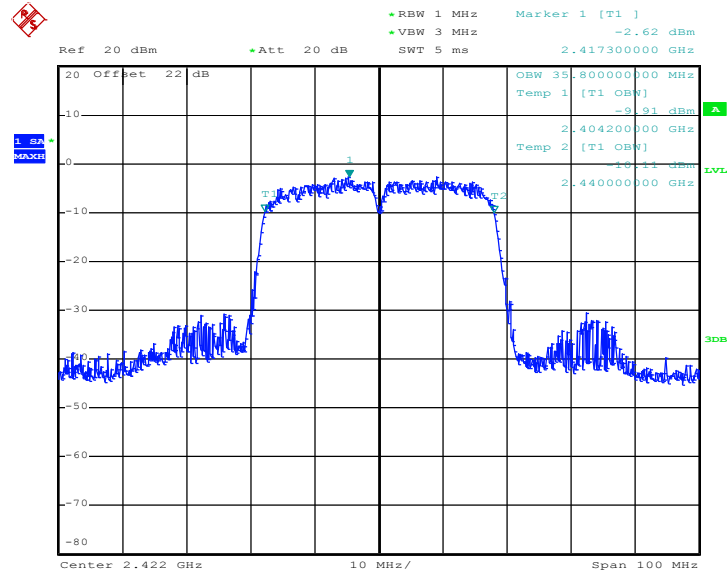

Date: 7.AUG.2012 07:14:51

802.11n HT-40 –MIMO Ant. 0+1(1)

99% Occupied Bandwidth Plot on Channel 06

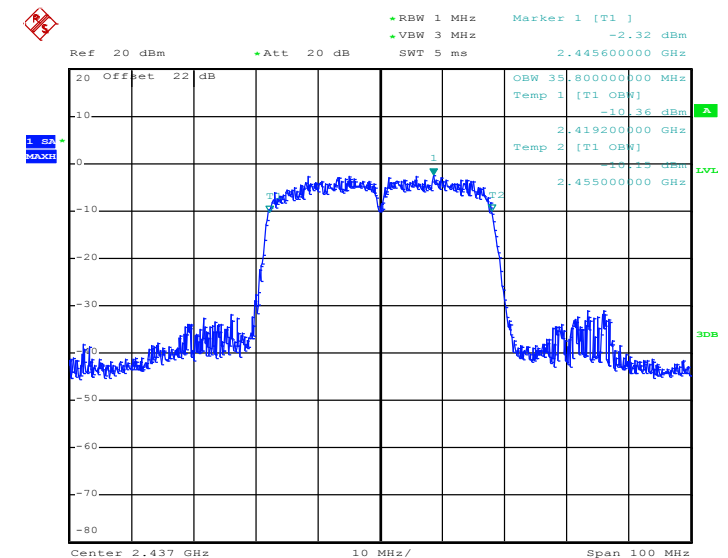

Date: 7.AUG.2012 07:23:43

3.2 Output Power Measurement

3.2.1 Limit of Output Power

For systems using digital modulation in the 2400-2483.5MHz and 5725-5850MHz, the limit for peak output power is 30dBm. If transmitting Antenna of directional gain greater than 6dBi are used the peak output power from the intentional radiator shall be reduced below the above stated value by the amount in dB that the directional gain of the Antenna exceeds 6 dBi. In case of point-to-point operation, the limit has to be reduced by 1dB for every 3dB that the directional gain of the Antenna exceeds 6dBi.

3.2.2 Measuring Instruments

See list of measuring instruments of this test report.

3.2.3 Test Procedures

1. The testing follows the Measurement Procedure of FCC KDB No. 558074 DTS D01 Meas. Guidance and TCB Workshop 2012, April.
2. The RF output of EUT was connected to the power meter by a low loss cable
3. Set to the maximum power setting and enable the EUT transmit continuously.
4. Measure the conducted output power and record the results in the test report.
5. For MIMO mode, calculation method follows FCC KDB 662911 D01 Multiple Transmitter Output v01r01.

3.2.4 Test Setup

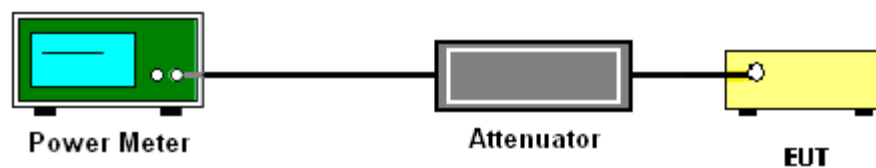

3.2.5 Test Result of Peak Output Power

Test Mode :	802.11b	Temperature :	24~26°C
Test Engineer :	Bill Kuo	Relative Humidity :	55~58%

Ch.	Frequency (MHz)	802.11b Peak Output Power (dBm)				Max. Limits (dBm)	Pass/Fail
		SISO Ant. 0	MIMO <Ant. 0+1(0)>	MIMO <Ant. 0+1(1)>	MIMO <Ant. 0+1>		
01	2412	16.54	15.22	6.46	15.76	SISO < 30.00 MIMO < 29.23	Pass
06	2437	16.33	14.89	5.87	15.40	SISO < 30.00 MIMO < 29.23	Pass
11	2462	16.37	14.90	6.62	15.50	SISO < 30.00 MIMO < 29.23	Pass

Test Mode :	802.11g	Temperature :	24~26°C
Test Engineer :	Bill Kuo	Relative Humidity :	55~58%

Ch.	Frequency (MHz)	802.11g Peak Output Power (dBm)				Max. Limits (dBm)	Pass/Fail
		SISO Ant. 0	MIMO <Ant. 0+1(0)>	MIMO <Ant. 0+1(1)>	MIMO <Ant. 0+1>		
01	2412	22.32	21.32	11.65	21.68	SISO < 30.00 MIMO < 29.23	Pass
06	2437	21.81	21.12	11.42	21.56	SISO < 30.00 MIMO < 29.23	Pass
11	2462	21.44	20.99	11.13	21.42	SISO < 30.00 MIMO < 29.23	Pass



Test Mode :	802.11n HT-20	Temperature :	24~26°C
Test Engineer :	Bill Kuo	Relative Humidity :	55~58%

Ch.	Frequency (MHz)	802.11n HT-20 Peak Output Power (dBm)				Max. Limits (dBm)	Pass/Fail
		SISO Ant. 0	MIMO <Ant. 0+1(0)>	MIMO <Ant. 0+1(1)>	MIMO <Ant. 0+1>		
01	2412	22.07	21.33	13.01	21.93	SISO < 30.00 MIMO < 29.23	Pass
06	2437	21.62	20.47	12.61	21.13	SISO < 30.00 MIMO < 29.23	Pass
11	2462	21.51	20.54	12.94	21.24	SISO < 30.00 MIMO < 29.23	Pass

Test Mode :	802.11n HT-40	Temperature :	24~26°C
Test Engineer :	Bill Kuo	Relative Humidity :	55~58%

Ch.	Frequency (MHz)	802.11n HT-40 Peak Output Power (dBm)				Max. Limits (dBm)	Pass/Fail
		SISO Ant. 0	MIMO <Ant. 0+1(0)>	MIMO <Ant. 0+1(1)>	MIMO <Ant. 0+1>		
03	2422	22.66	23.00	14.73	23.60	SISO < 30.00 MIMO < 29.23	Pass
06	2437	22.31	22.55	14.82	23.23	SISO < 30.00 MIMO < 29.23	Pass
09	2452	21.97	22.10	15.05	22.88	SISO < 30.00 MIMO < 29.23	Pass

3.2.6 Test Result of Average output Power (Reporting Only)

Test Mode :	802.11b	Temperature :	24~26°C
Test Engineer :	Bill Kuo	Relative Humidity :	55~58%
Duty Cycle:	100.00% for SISO Ant. 0 100.00% for MIMO <Ant. 0+1(0)> 100.00% for MIMO <Ant. 0+1(1)>	Duty Factor:	0.00dB for SISO Ant. 0 0.00dB for MIMO <Ant. 0+1(0)> 0.00dB for MIMO <Ant. 0+1(1)>

Channel	Frequency (MHz)	802.11b Average Output Power (dBm)			
		SISO Ant. 0	MIMO <Ant. 0+1(0)>	MIMO <Ant. 0+1(1)>	MIMO <Ant. 0+1>
01	2412	14.09	12.87	3.73	13.37
06	2437	13.89	12.81	3.67	13.31
11	2462	13.91	12.54	4.34	13.15

Note :

1. MIMO ANT 0+1 is a calculated result from sum of the power MIMO ANT 0 and MIMO ANT 1.
2. The average power is measured by power meter with average power sensor and is reporting only.



Test Mode :	802.11g	Temperature :	24~26°C
Test Engineer :	Bill Kuo	Relative Humidity :	55~58%
Duty Cycle:	98.91% for SISO Ant. 0 98.63% for MIMO <Ant 0+1(0)> 97.96% for MIMO <Ant 0+1(1)>	Duty Factor:	0.05dB for SISO Ant. 0 0.06dB for MIMO <Ant 0+1(0)> 0.09dB for MIMO <Ant 0+1(1)>

Channel	Frequency (MHz)	802.11g			
		Average Output Power (dBm)			
		SISO Ant. 0	MIMO <Ant. 0+1(0)>	MIMO <Ant. 0+1(1)>	MIMO <Ant. 0+1>
01	2412	11.98	11.05	1.43	11.50
06	2437	11.44	10.97	0.68	11.36
11	2462	11.20	10.89	0.60	11.28

Note :

1. MIMO ANT 0+1 is a calculated result from sum of the power MIMO ANT 0 and MIMO ANT 1.
2. The average power is measured by power meter with average power sensor and is reporting only.



Test Mode :	802.11n HT-20	Temperature :	24~26°C
Test Engineer :	Bill Kuo	Relative Humidity :	55~58%
Duty Cycle:	83.41% for SISO Ant. 0 82.21% for MIMO <Ant 0+1(0)> 83.33% for MIMO <Ant 0+1(1)>	Duty Factor:	0.79dB for SISO Ant. 0 0.85dB for MIMO <Ant 0+1(0)> 0.79dB for MIMO <Ant 0+1(1)>

Channel	Frequency (MHz)	802.11n HT-20 Average Output Power (dBm)			
		SISO Ant. 0	MIMO <Ant. 0+1(0)>	MIMO <Ant. 0+1(1)>	MIMO <Ant. 0+1>
01	2412	11.97	11.48	2.95	12.05
06	2437	11.26	10.56	2.83	11.24
11	2462	11.55	10.48	3.24	11.23

Note :

1. MIMO ANT 0+1 is a calculated result from sum of the power MIMO ANT 0 and MIMO ANT 1.
2. The average power is measured by power meter with average power sensor and is reporting only.



Test Mode :	802.11n HT-40	Temperature :	24~26°C
Test Engineer :	Bill Kuo	Relative Humidity :	55~58%
Duty Cycle:	81.73% for SISO Ant. 0 82.05% for MIMO <Ant 0+1(0)> 81.63% for MIMO <Ant 0+1(1)>	Duty Factor:	0.88dB for SISO Ant. 0 0.86dB for MIMO <Ant 0+1(0)> 0.88dB for MIMO <Ant 0+1(1)>

Channel	Frequency (MHz)	802.11n HT-40 Average Output Power (dBm)			
		SISO Ant. 0	MIMO <Ant. 0+1(0)>	MIMO <Ant. 0+1(1)>	MIMO <Ant. 0+1>
03	2422	11.60	12.32	3.36	12.84
06	2437	11.34	11.51	3.56	12.16
09	2452	10.69	11.28	3.89	12.01

Note :

1. MIMO ANT 0+1 is a calculated result from sum of the power MIMO ANT 0 and MIMO ANT 1.
2. The average power is measured by power meter with average power sensor and is reporting only.



3.3 Power Spectral Density Measurement

3.3.1 Limit of Power Spectral Density

The peak power spectral density shall not be greater than 8dBm in any 3KHz band at any time interval of continuous transmission.

3.3.2 Measuring Instruments

See list of measuring instruments of this test report.

3.3.3 Test Procedures

1. The testing follows Measurement Procedure 5.3.1 (Peak PSD) of FCC KDB Publication No. 558074 D01 DTS Meas. Guidance and TCB Workshop 2012, April.
2. The RF output of EUT was connected to the spectrum analyzer by a low loss cable. The path loss was compensated to the results for each measurement.
3. Set to the maximum power setting and enable the EUT transmit continuously.
4. Make the measurement with the spectrum analyzer's resolution bandwidth (RBW) = 100 KHz. Video bandwidth (VBW) \geq 300 KHz In order to make an accurate measurement, set the span to 5-30% greater than Emission Bandwidth (EBW)
5. Detector = peak, Sweep time = auto couple, Trace mode = max hold, Allow trace to fully stabilize. Use the peak marker function to determine the maximum power level in any 100 kHz band segment within the fundamental EBW.
6. Record the measurement data derived from spectrum analyzer.
7. Scale the observed power level to an equivalent value in 3 kHz by adjusting (reducing) the measured power by a bandwidth correction factor (BWCF) where $BWCF = 10\log(3\text{ kHz}/100\text{ kHz} = -15.2\text{ dB})$.
8. For MIMO mode, calculation method follows FCC KDB 662911 D01 Multiple Transmitter Output v01r01.

If measurements performed using method (2) plus $10\log(N)$ exceeds the emission limit, the test should choose method (1) before declaring that the device fails the emission limit.

Method (1): Measure and sum the spectra across the outputs.

The total final Power Spectral Density is from a device with 2 transmitter outputs. The spectrum measurements of the individual outputs are all performed with the same span and number of points, the spectrum value in the first spectral bin of output 1 is summed with that in the first spectral bin of output 2 to obtain the value for the first frequency bin of the summed spectrum.

Method (2): Measure and add $10\log(N)$ dB, where N is the number of outputs. (N=2)

3.3.4 Test Setup

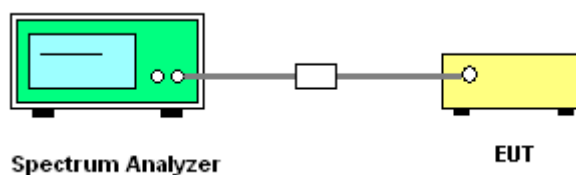

3.3.5 Test Result of Power Spectral Density

Test Mode :	802.11b	Temperature :	24~26°C
Test Engineer :	Bill Kuo	Relative Humidity :	55~58%

Ch.	Freq. (MHz)	802.11b Power Density						Max. Limits (dBm)	Pass /Fail
		SISO Ant. 0		MIMO <Ant. 0+1(0)>		MIMO <Ant. 0+1(1)>			
		Measured PSD/100KHz (dBm)	PSD/3KHz (dBm)	Measured PSD/100KHz (dBm)	PSD/3KHz (dBm) +10log2	Measured PSD/100KHz (dBm)	PSD/3KHz (dBm) +10log2		
01	2412	0.17	-15.03	-0.49	-15.69	-9.92	-25.12	SISO < 8.00 MIMO < 7.23	Pass
06	2437	2.89	-12.31	0.91	-14.29	-8.66	-23.86	SISO < 8.00 MIMO < 7.23	Pass
11	2462	3.80	-11.40	-0.31	-15.51	-8.15	-23.35	SISO < 8.00 MIMO < 7.23	Pass

Test Mode :	802.11g	Temperature :	24~26°C
Test Engineer :	Bill Kuo	Relative Humidity :	55~58%

Ch.	Freq. (MHz)	802.11g Power Density						Max. Limits (dBm)	Pass /Fail
		SISO Ant. 0		MIMO <Ant. 0+1(0)>		MIMO <Ant. 0+1(1)>			
		Measured PSD/100KHz (dBm)	PSD/3KHz (dBm)	Measured PSD/100KHz (dBm)	PSD/3KHz (dBm) +10log2	Measured PSD/100KHz (dBm)	PSD/3KHz (dBm) +10log2		
01	2412	0.43	-14.77	-3.21	-18.41	-12.65	-27.85	SISO < 8.00 MIMO < 7.23	Pass
06	2437	0.14	-15.06	-2.50	-17.70	-11.21	-26.41	SISO < 8.00 MIMO < 7.23	Pass
11	2462	0.25	-14.95	-2.68	-17.88	-10.36	-25.56	SISO < 8.00 MIMO < 7.23	Pass



Test Mode :	802.11n HT-20	Temperature :	24~26°C
Test Engineer :	Bill Kuo	Relative Humidity :	55~58%

Ch.	Freq. (MHz)	802.11n HT-20 Power Density						Max. Limits (dBm)	Pass /Fail
		SISO Ant. 0		MIMO <Ant. 0+1(0)>		MIMO <Ant. 0+1(1)>			
		Measured PSD/100KHz (dBm)	PSD/3KHz (dBm)	Measured PSD/100KHz (dBm)	PSD/3KHz (dBm) +10log2	Measured PSD/100KHz (dBm)	PSD/3KHz (dBm) +10log2		
01	2412	0.92	-14.28	1.09	-14.11	-8.36	-23.56	SISO < 8.00 MIMO < 7.23	Pass
06	2437	0.52	-14.68	0.74	-14.46	-8.10	-23.30	SISO < 8.00 MIMO < 7.23	Pass
11	2462	0.79	-14.41	0.58	-14.62	-7.71	-22.91	SISO < 8.00 MIMO < 7.23	Pass

Test Mode :	802.11n HT-40	Temperature :	24~26°C
Test Engineer :	Bill Kuo	Relative Humidity :	55~58%

Ch.	Freq. (MHz)	802.11n HT-40 Power Density						Max. Limits (dBm)	Pass /Fail
		SISO Ant. 0		MIMO <Ant. 0+1(0)>		MIMO <Ant. 0+1(1)>			
		Measured PSD/100KHz (dBm)	PSD/3KHz (dBm)	Measured PSD/100KHz (dBm)	PSD/3KHz (dBm) +10log2	Measured PSD/100KHz (dBm)	PSD/3KHz (dBm) +10log2		
03	2422	-2.24	-17.44	-2.10	-17.30	-10.69	-25.89	SISO < 8.00 MIMO < 7.23	Pass
06	2437	-2.35	-17.55	-2.07	-17.27	-10.49	-25.69	SISO < 8.00 MIMO < 7.23	Pass
09	2452	-2.67	-17.87	-1.44	-16.64	-9.93	-25.13	SISO < 8.00 MIMO < 7.23	Pass

Note:

1. Measured power density (dBm) has offset with cable loss.
2. BWCF (dB) = 10 log (3k/100k) = -15.2 dB
3. Power Density/ 3KHz (dBm)= Measured power density/ 100KHz (dBm) + BWCF (dB)
4. MIMO Power Density/ 3KHz (dBm)= Measured power density/ 100KHz (dBm) + BWCF (dB) + 10LOG(N=2), where N=2 transmitters.



3.3.6 Test Result of Power Spectral Density Plots

802.11b –SISO Ant. 0

PSD Plot on Channel 01

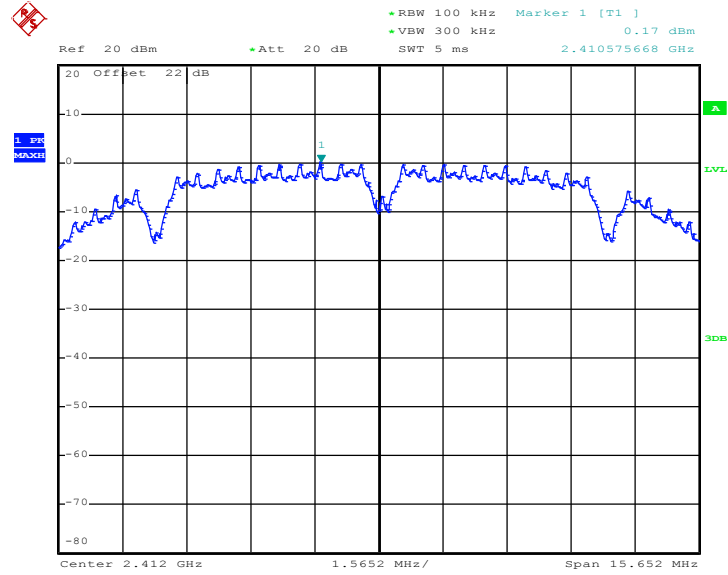

Date: 7.AUG.2012 04:58:20

802.11b –SISO Ant. 0

PSD Plot on Channel 06

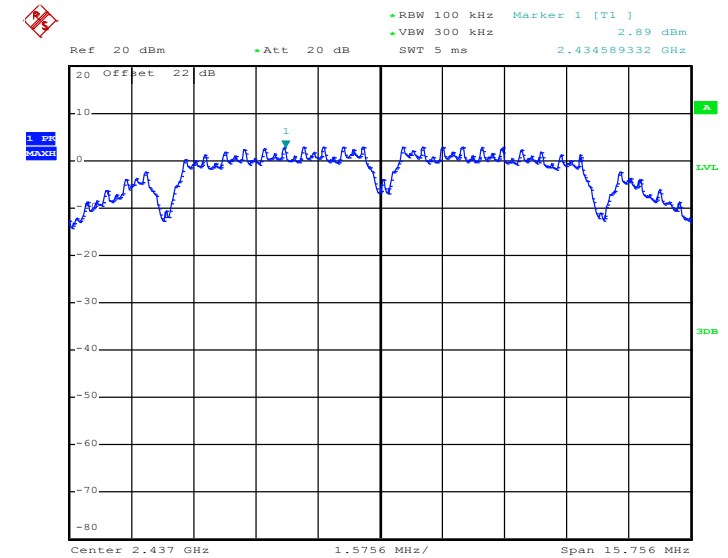

Date: 7.AUG.2012 05:02:32



802.11b –SISO Ant. 0

PSD Plot on Channel 11

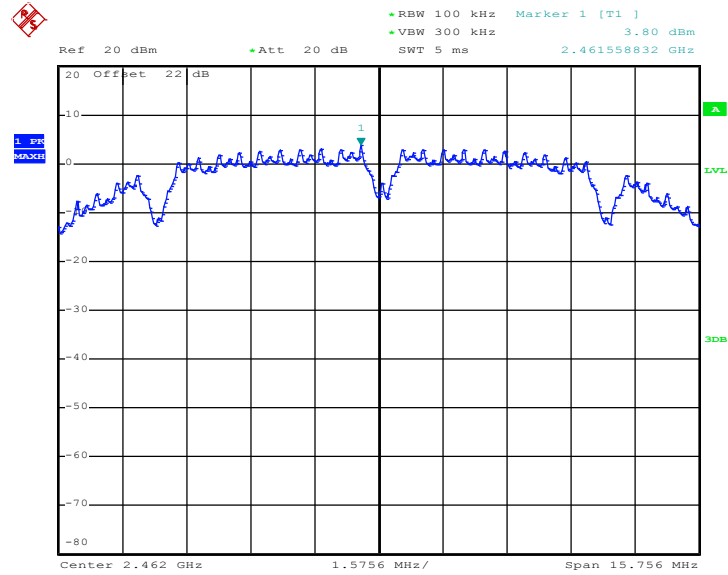

Date: 7.AUG.2012 05:06:08

802.11b –MIMO Ant. 0+1(0)

PSD Plot on Channel 01

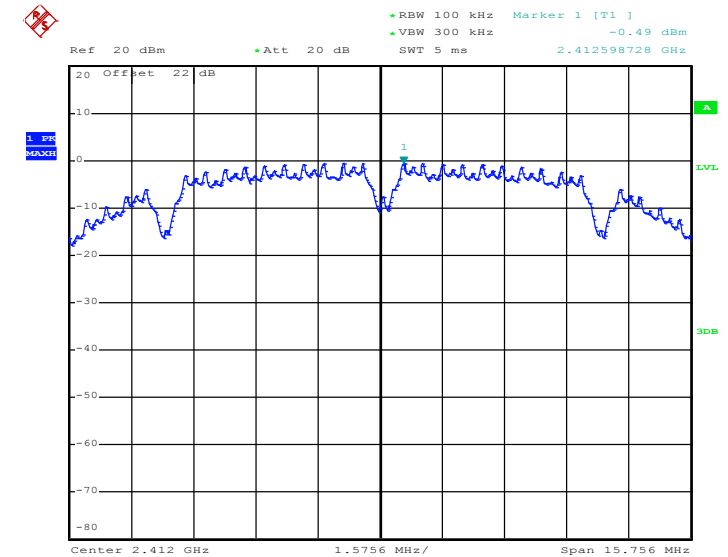

Date: 7.AUG.2012 05:19:31



802.11b –MIMO Ant. 0+1(0)

PSD Plot on Channel 06

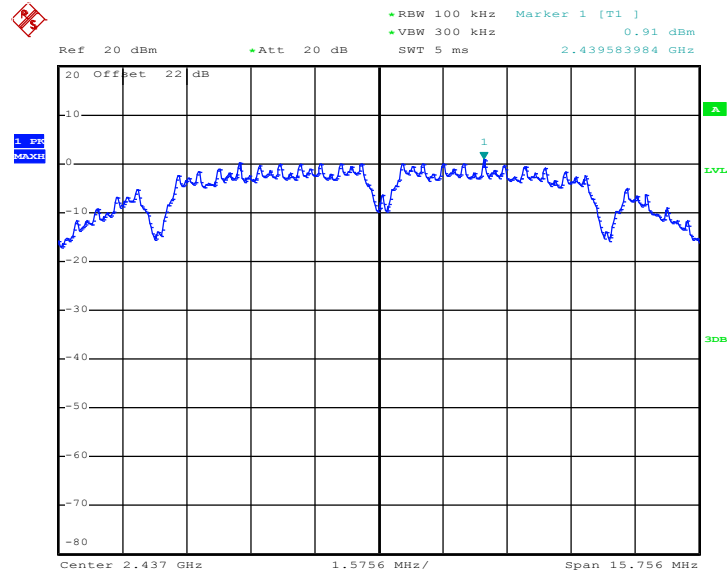

Date: 7.AUG.2012 05:15:46

802.11b –MIMO Ant. 0+1(0)

PSD Plot on Channel 11

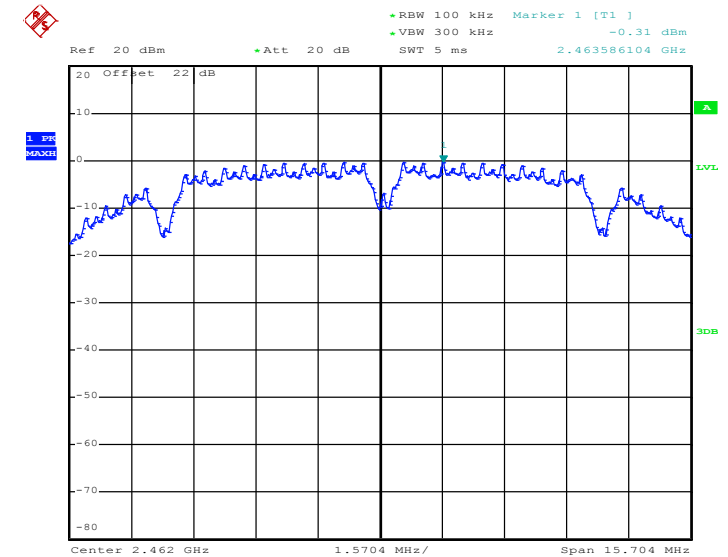

Date: 7.AUG.2012 05:09:31



802.11b –MIMO Ant. 0+1(1)

PSD Plot on Channel 01

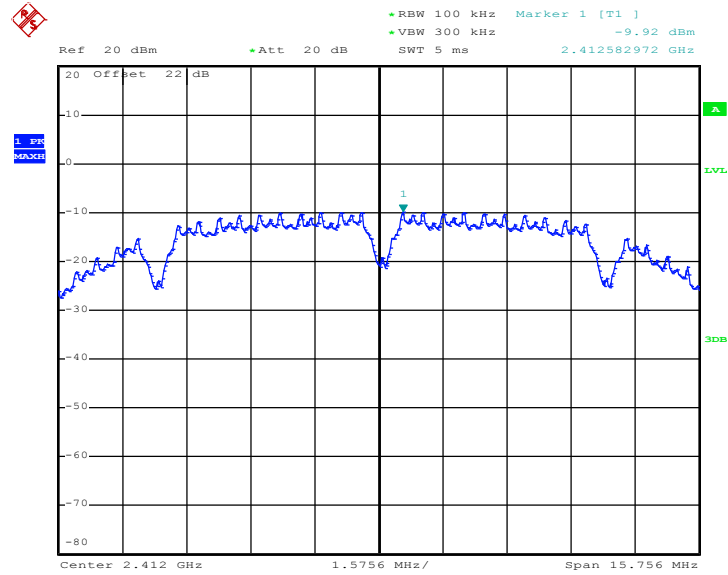

Date: 7.AUG.2012 08:04:30

802.11b –MIMO Ant. 0+1(1)

PSD Plot on Channel 06

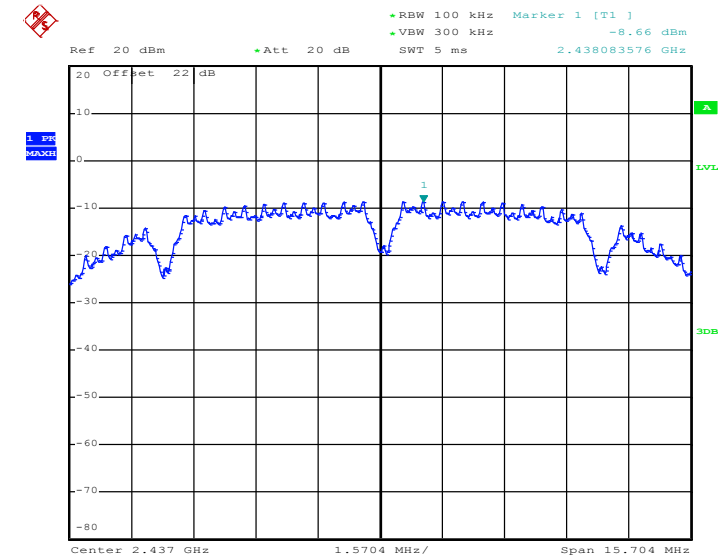

Date: 7.AUG.2012 08:07:27



802.11b –MIMO Ant. 0+1(1)

PSD Plot on Channel 11

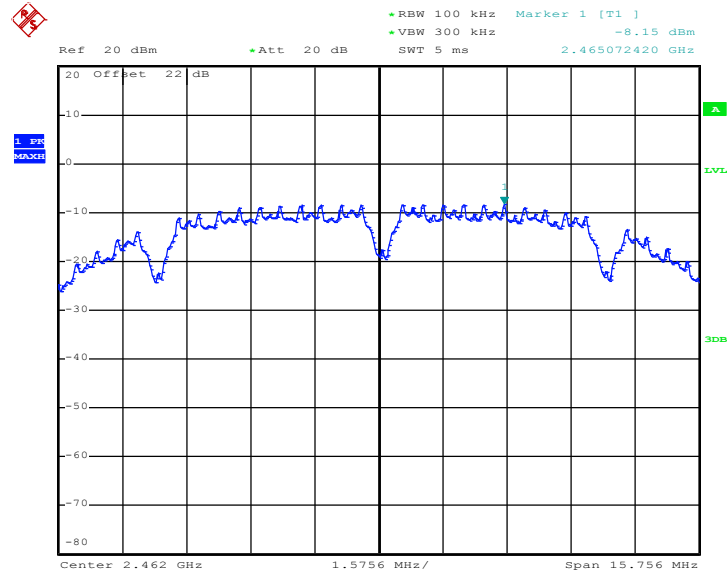

Date: 7.AUG.2012 08:10:02



802.11g –SISO Ant. 0

PSD Plot on Channel 01

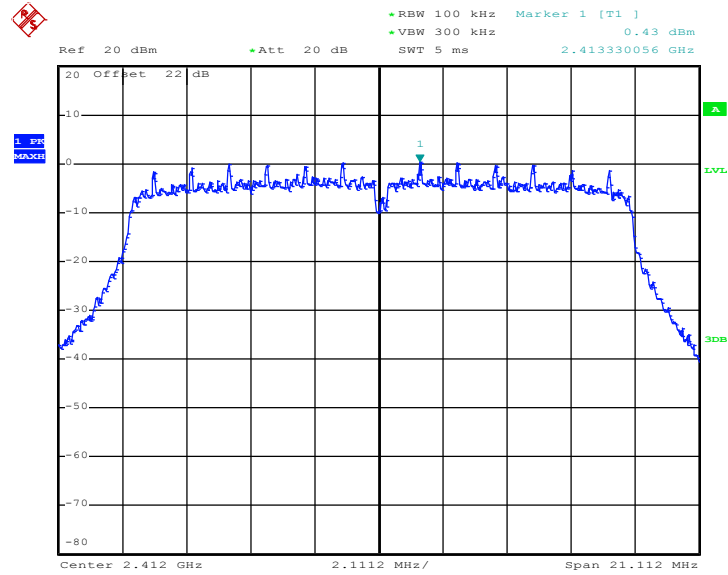

Date: 7.AUG.2012 05:24:55

802.11g –SISO Ant. 0

PSD Plot on Channel 06

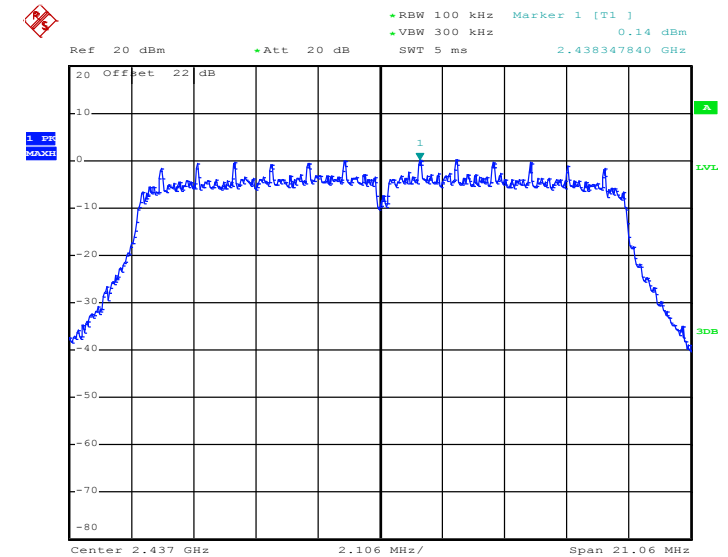

Date: 7.AUG.2012 05:28:42



802.11g –SISO Ant. 0

PSD Plot Channel 11

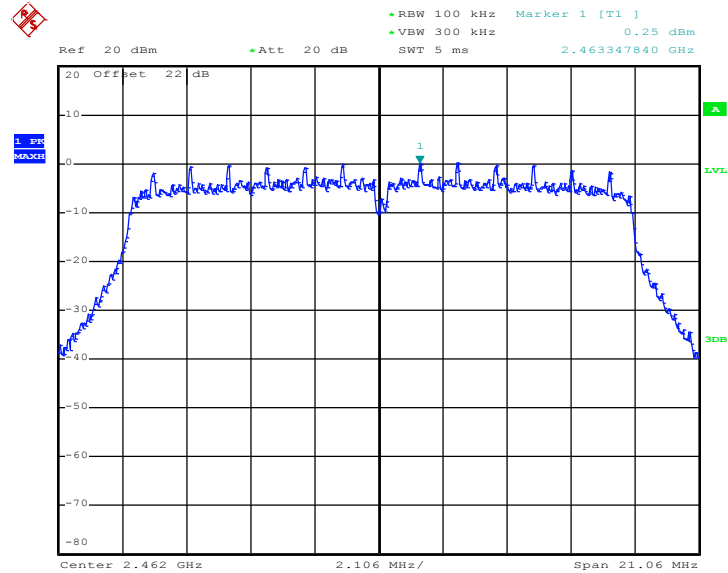

Date: 7.AUG.2012 05:31:50

802.11g –MIMO Ant. 0+1(0)

PSD Plot on Channel 01

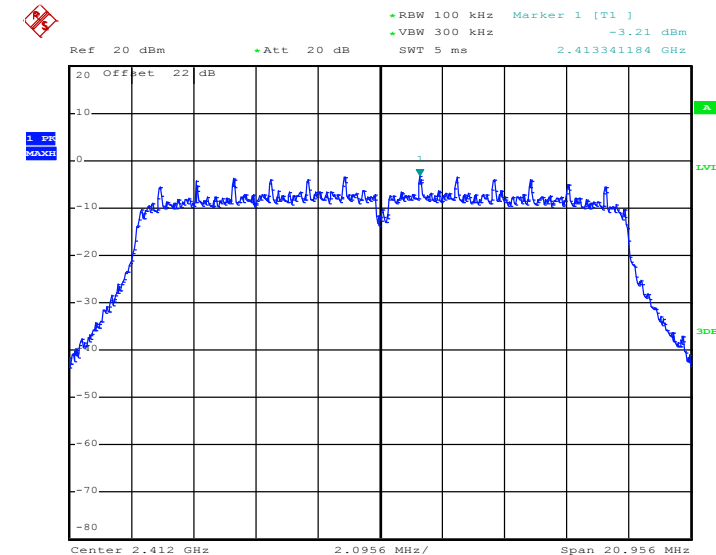

Date: 7.AUG.2012 05:43:44

802.11g –MIMO Ant. 0+1(0)

PSD Plot on Channel 06

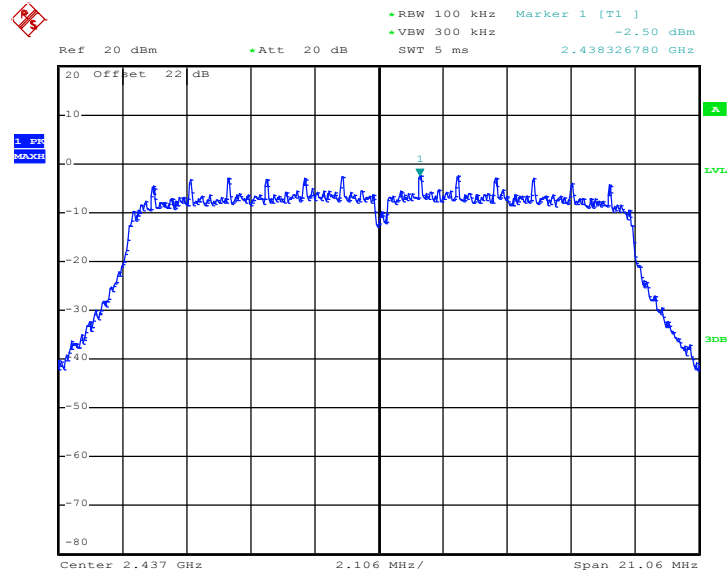

Date: 7.AUG.2012 05:40:09

802.11g –MIMO Ant. 0+1(0)

PSD Plot on Channel 11

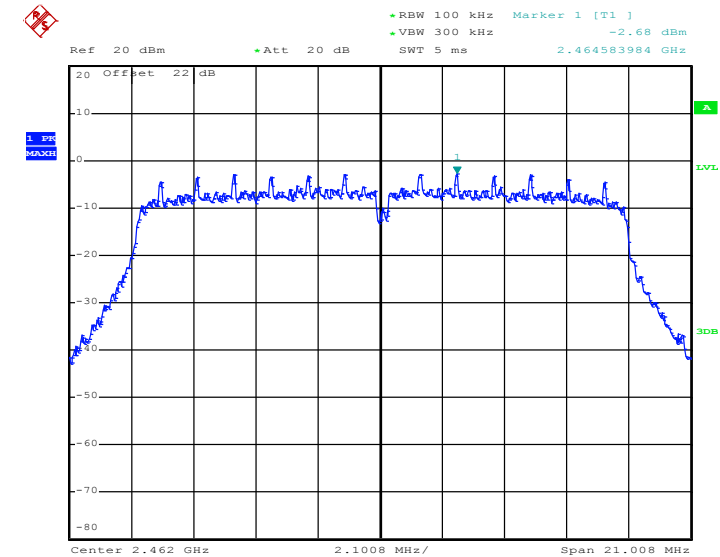

Date: 7.AUG.2012 05:36:06



802.11g –MIMO Ant. 0+1(1)

PSD Plot on Channel 01

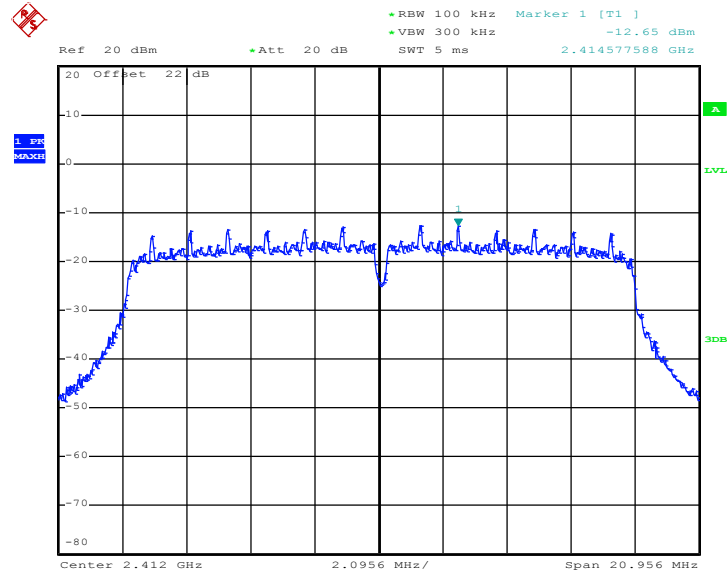

Date: 7.AUG.2012 08:00:51

802.11g –MIMO Ant. 0+1(1)

PSD Plot on Channel 06

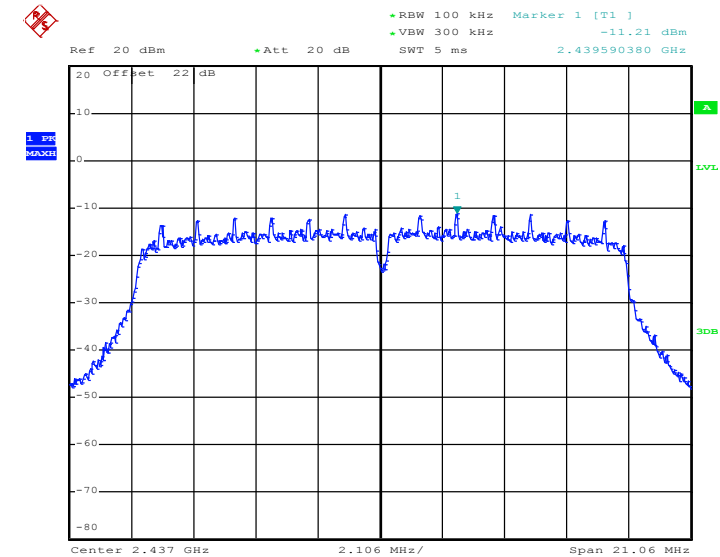

Date: 7.AUG.2012 07:58:02



802.11g –MIMO Ant. 0+1(1)

PSD Plot on Channel 11

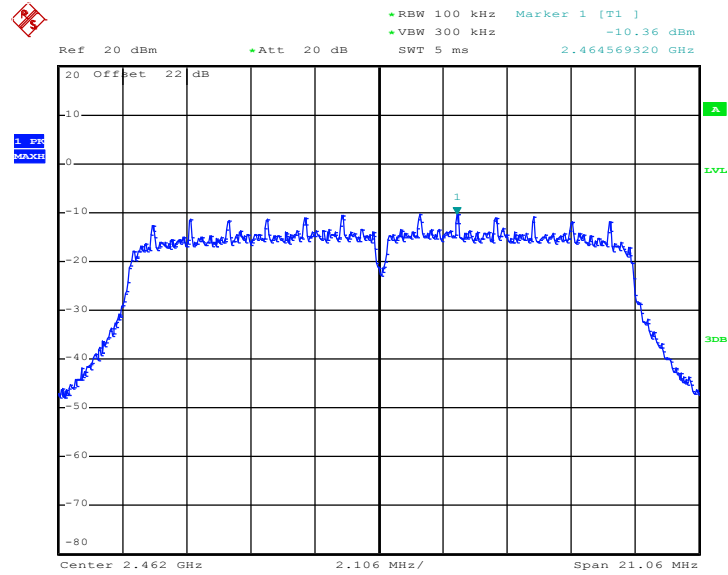

Date: 7.AUG.2012 07:51:59



802.11n HT-20 – SISO Ant. 0

PSD Plot on Channel 01

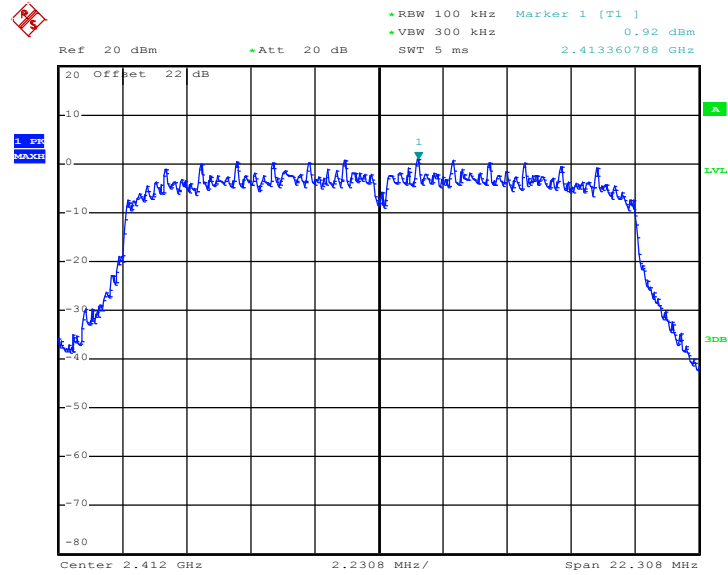

Date: 7.AUG.2012 05:50:01

802.11n HT-20 – SISO Ant. 0

PSD Plot on Channel 06

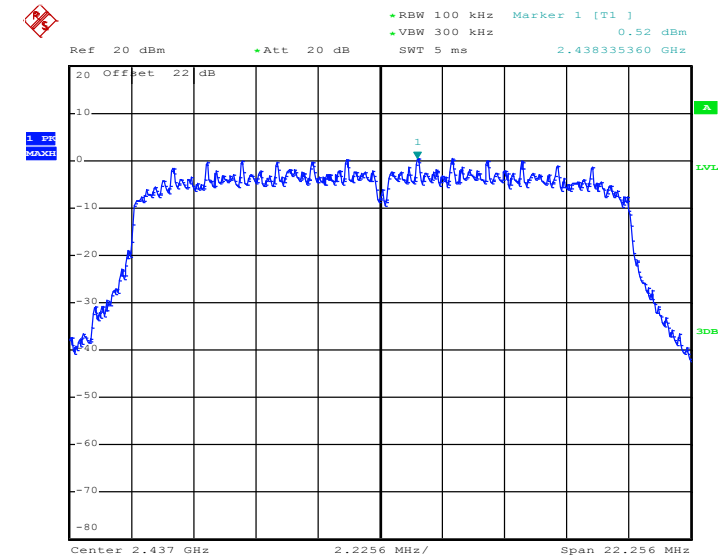

Date: 7.AUG.2012 05:55:48



802.11n HT-20 – SISO Ant. 0

PSD Plot on Channel 11

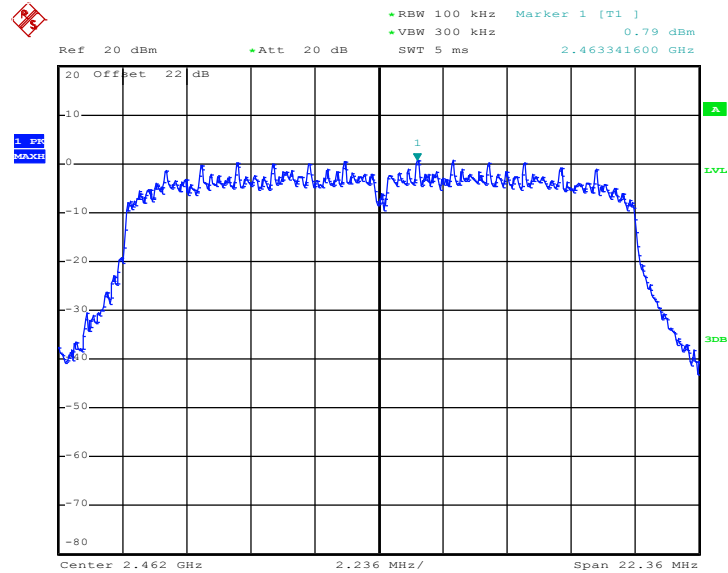

Date: 7.AUG.2012 05:59:27

802.11n HT-20 –MIMO Ant. 0+1(0)

PSD Plot on Channel 01

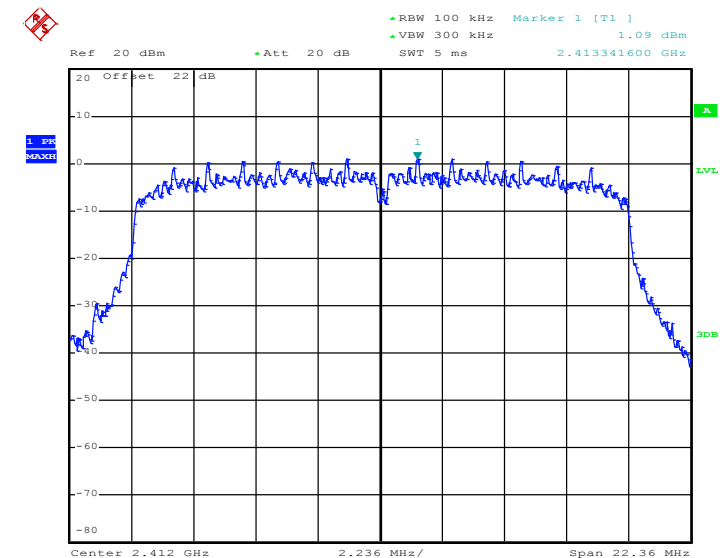

Date: 7.AUG.2012 06:10:30

802.11n HT-20 –MIMO Ant. 0+1(0)

PSD Plot on Channel 06

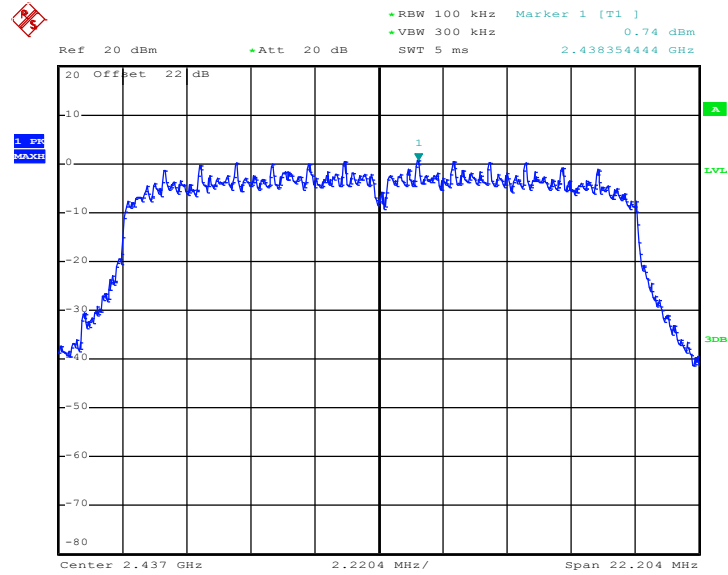

Date: 7.AUG.2012 06:07:09

802.11n HT-20 –MIMO Ant. 0+1(0)

PSD Plot on Channel 11

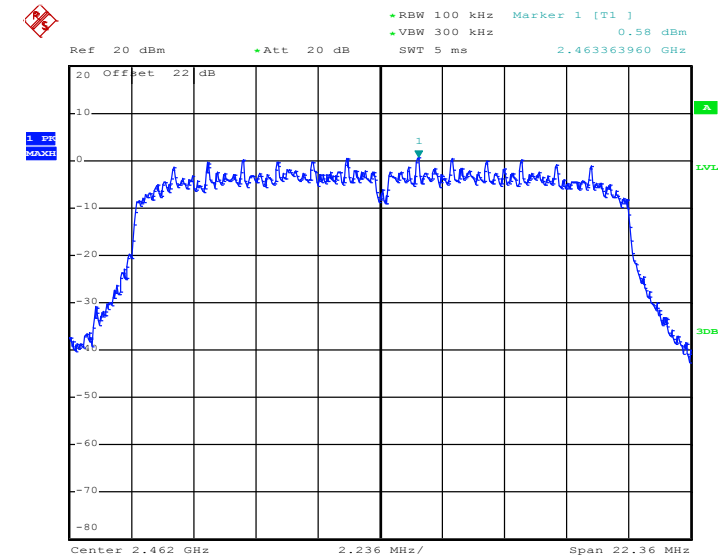

Date: 7.AUG.2012 06:03:32



802.11n HT-20 –MIMO Ant. 0+1(1)

PSD Plot on Channel 01

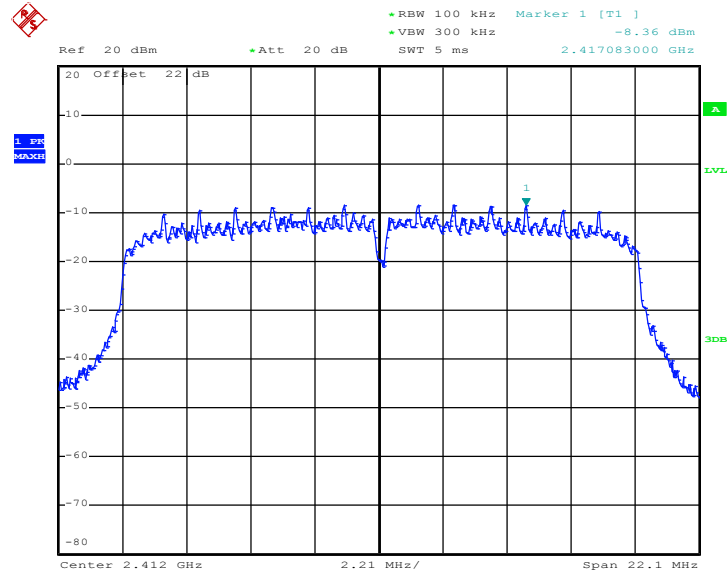

Date: 7.AUG.2012 07:38:45

802.11n HT-20 –MIMO Ant. 0+1(1)

PSD Plot on Channel 06

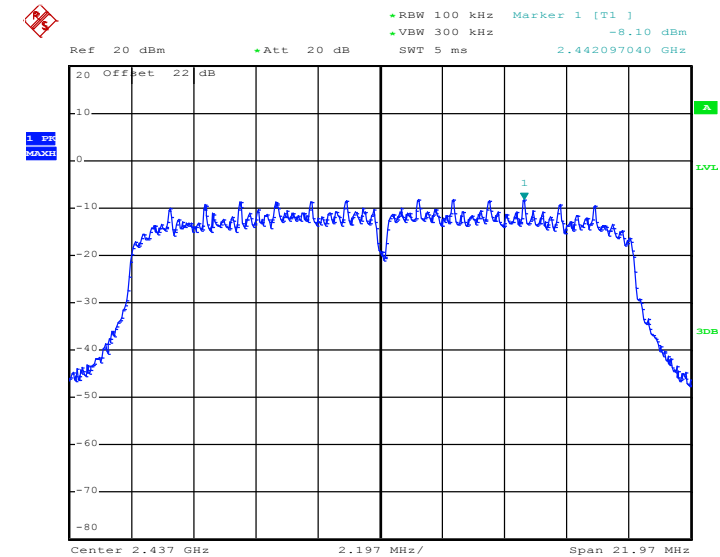

Date: 7.AUG.2012 07:42:56



802.11n HT-20 –MIMO Ant. 0+1(1)

PSD Plot on Channel 11

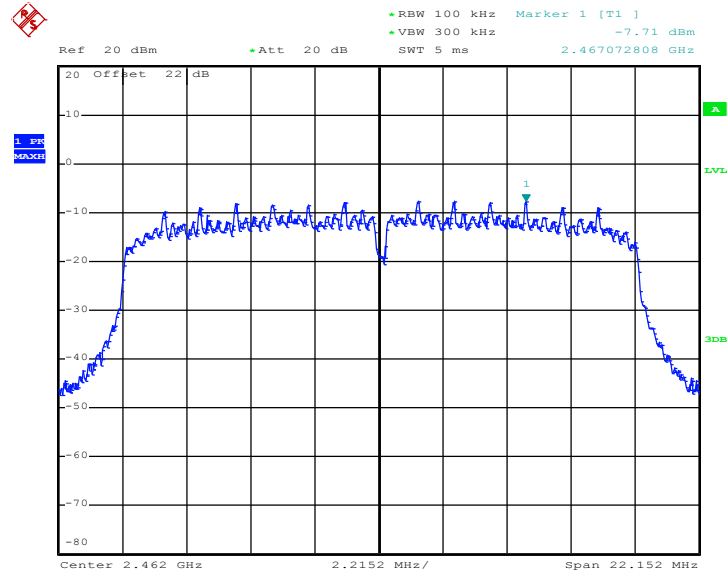

Date: 7.AUG.2012 07:46:26

802.11n HT-40 – SISO Ant. 0

PSD Plot on Channel 09

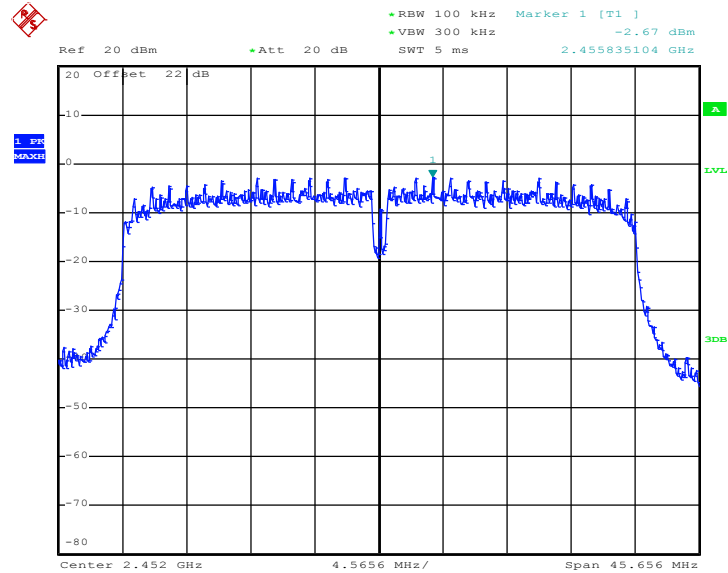

Date: 7.AUG.2012 06:54:56

802.11n HT-40 –MIMO Ant. 0+1(0)

PSD Plot on Channel 03

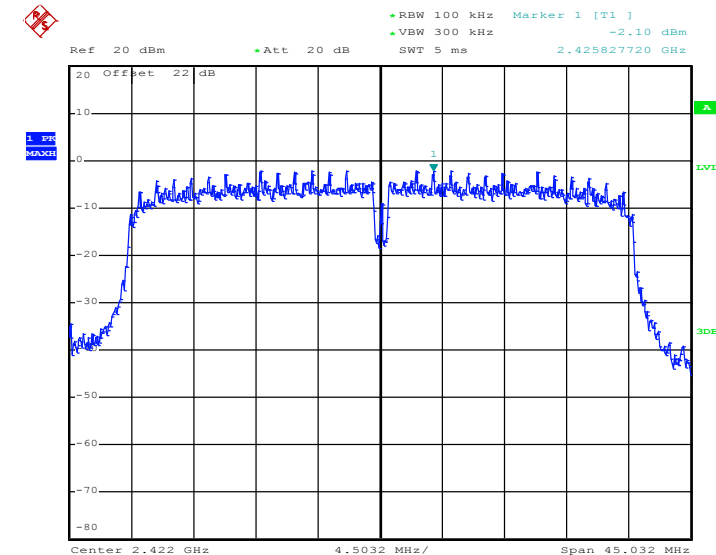

Date: 7.AUG.2012 07:08:24



802.11n HT-40 –MIMO Ant. 0+1(0)

PSD Plot on Channel 06

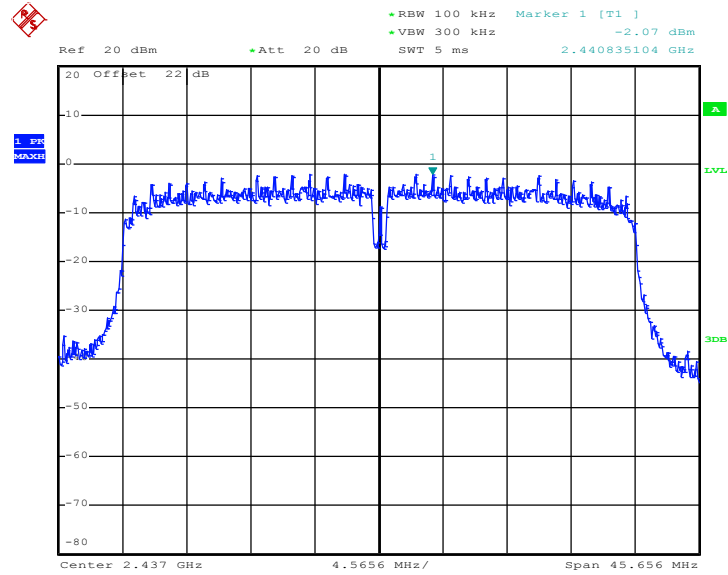

Date: 7.AUG.2012 07:04:53

802.11n HT-40 –MIMO Ant. 0+1(0)

PSD Plot on Channel 09

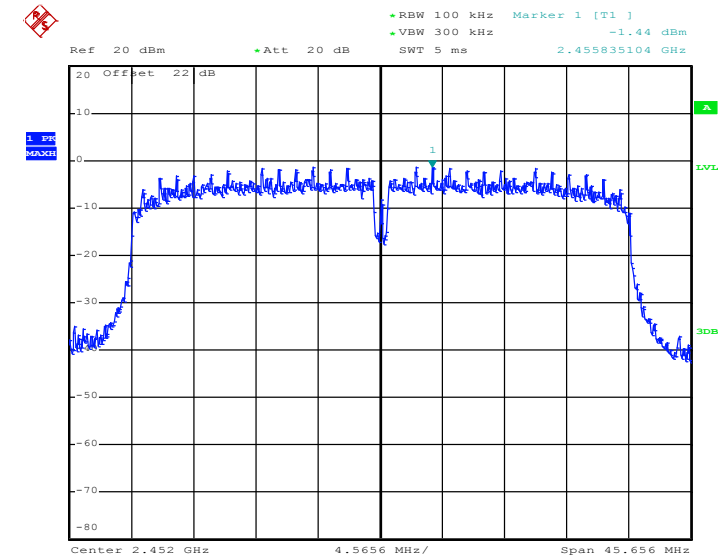

Date: 7.AUG.2012 06:59:56



802.11n HT-40 –MIMO Ant. 0+1(1)

PSD Plot on Channel 03

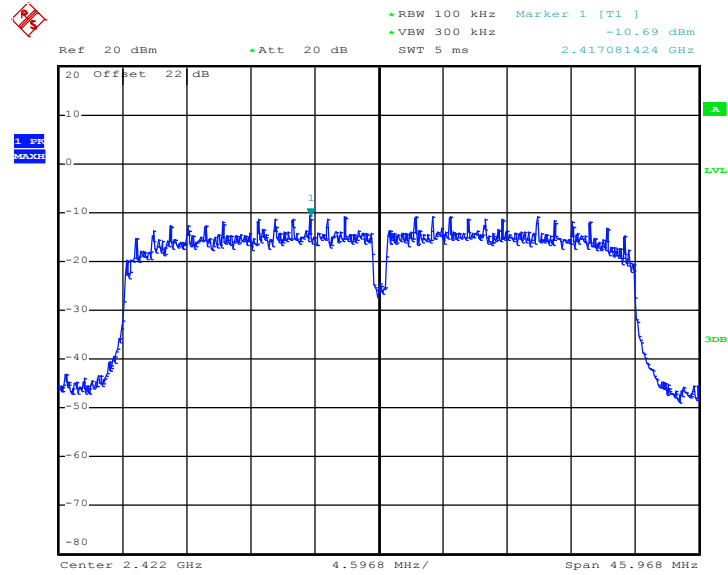

Date: 7.AUG.2012 07:13:12

802.11n HT-40 –MIMO Ant. 0+1(1)

PSD Plot on Channel 06

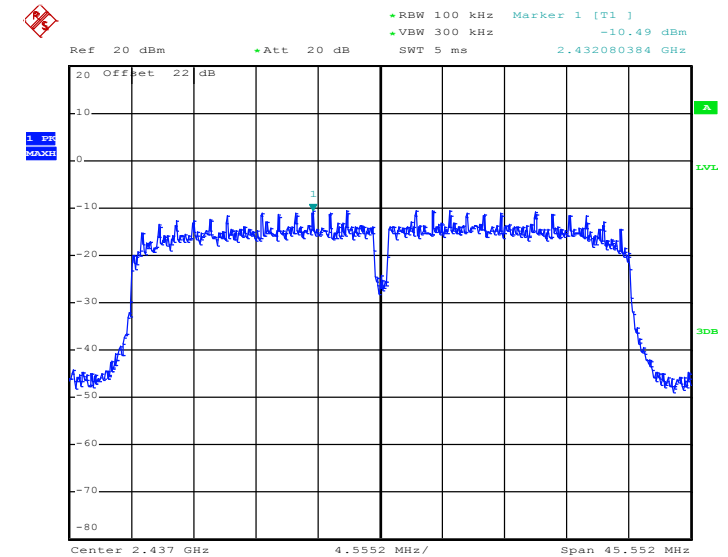

Date: 7.AUG.2012 07:20:03



802.11n HT-40 –MIMO Ant. 0+1(1)

PSD Plot on Channel 09

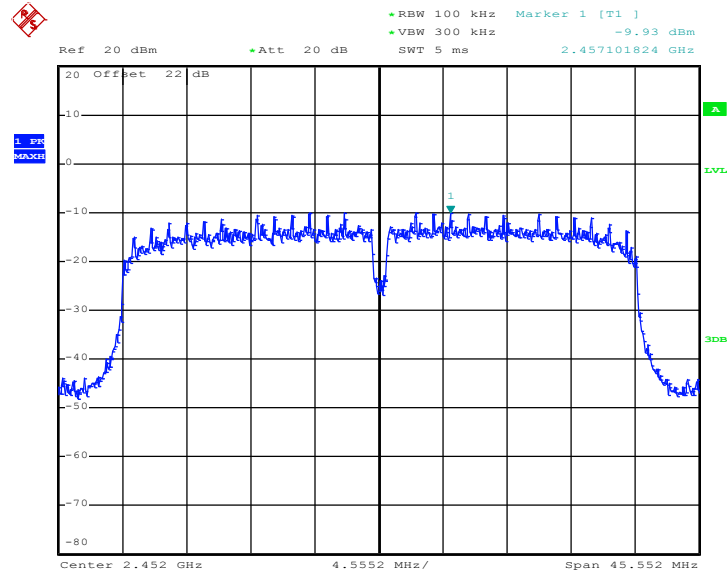

Date: 7.AUG.2012 07:29:03

3.4 Conducted Band Edges and Spurious Emission Measurement

3.4.1 Limit of Conducted Band Edges and Spurious Emission Measurement

In any 100 kHz bandwidth outside of the authorized frequency band, the emissions which fall in the non-restricted bands shall be attenuated at least 20 dB / 30dB relative to the maximum PSD level in 100 kHz by RF conducted measurement and radiated emissions which fall in the restricted bands, as defined in Section 15.205(a), must also comply with the radiated emission limits specified in Section 15.209(a).

3.4.2 Measuring Instruments

See list of measuring instruments of this test report.

3.4.3 Test Procedures

1. The testing follows the guidelines in the Measurement Procedure of FCC KDB Publication No. 558074 D01 DTS Meas. Guidance, ANSI C63.4-2003, and ANSI C63.10-2009.
2. Set to the maximum power setting and enable the EUT transmit continuously.
3. Set RBW = 100 KHz, VBW=300 KHz, Peak Detector. Unwanted Emissions measured in any 100 kHz bandwidth outside of the authorized frequency band shall be attenuated by at least 20 dB relative to the maximum in-band peak PSD level in 100 kHz, when maximum peak conducted output power procedure is used. The attenuation is set to 30dB, when maximum conducted output power procedure is used.
4. Measure and record the results in the test report.

3.4.4 Test Setup

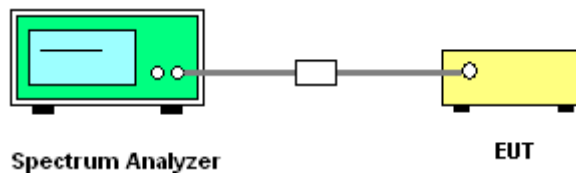



3.4.5 Test Result of Conducted Spurious at Band Edges

Test Mode :	802.11b (SISO Ant. 0)	Temperature :	24~26°C
Test Band :	Low and High	Relative Humidity :	55~58%
Test Channel :	01 and 11	Test Engineer :	Bill Kuo

802.11b

Low Band Edge Plot on Channel 01

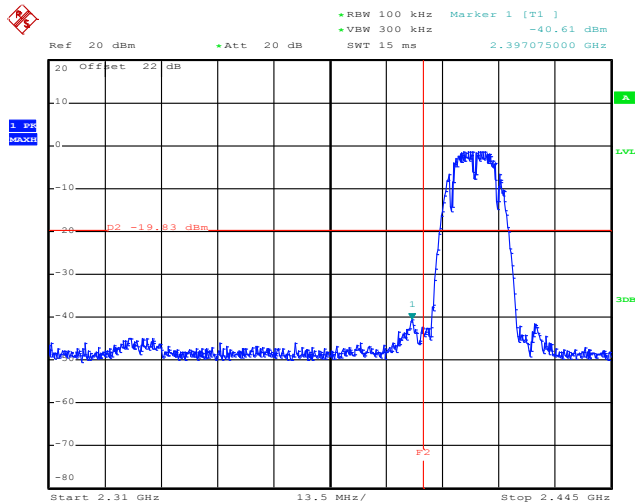

Date: 7.AUG.2012 04:58:36

802.11b

High Band Edge Plot on Channel 11

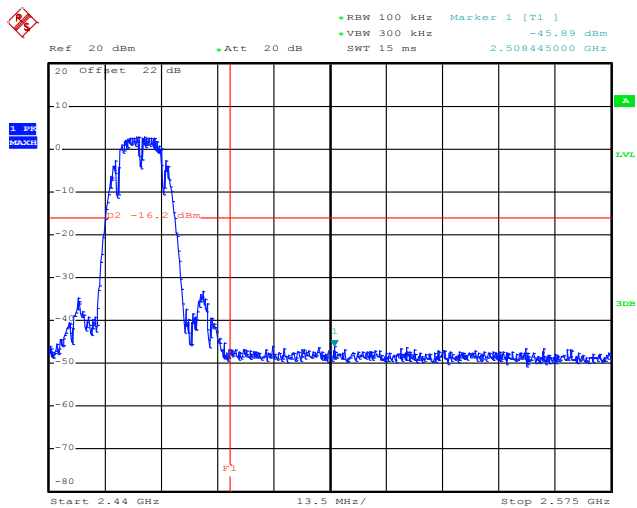

Date: 7.AUG.2012 05:06:22



Test Mode :	802.11b MIMO Ant. 0+1(0)	Temperature :	24~26°C
Test Band :	Low and High	Relative Humidity :	55~58%
Test Channel :	01 and 11	Test Engineer :	Bill Kuo

802.11b

Low Band Edge Plot on Channel 01

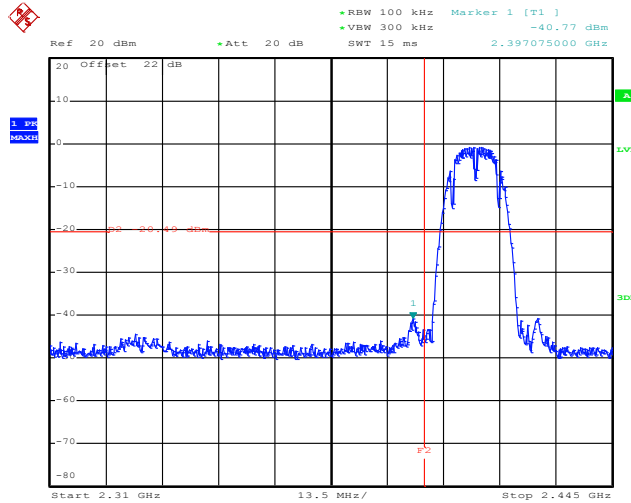

Date: 7.AUG.2012 05:19:46

802.11b

High Band Edge Plot on Channel 11

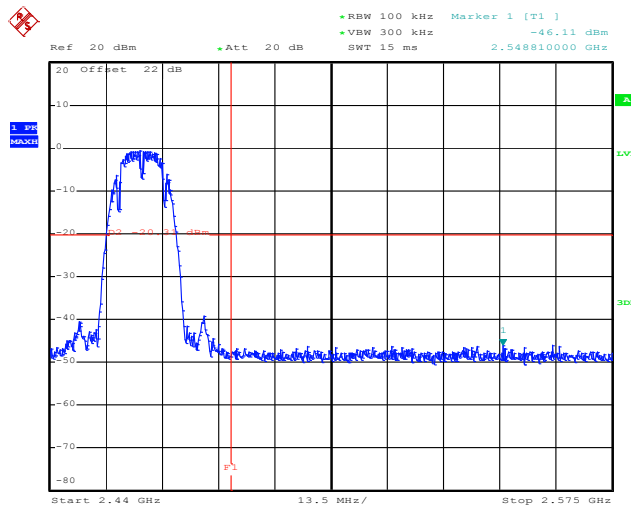

Date: 7.AUG.2012 05:09:55



Test Mode :	802.11b MIMO Ant. 0+1(1)	Temperature :	24~26°C
Test Band :	Low and High	Relative Humidity :	55~58%
Test Channel :	01 and 11	Test Engineer :	Bill Kuo

802.11b

Low Band Edge Plot on Channel 01

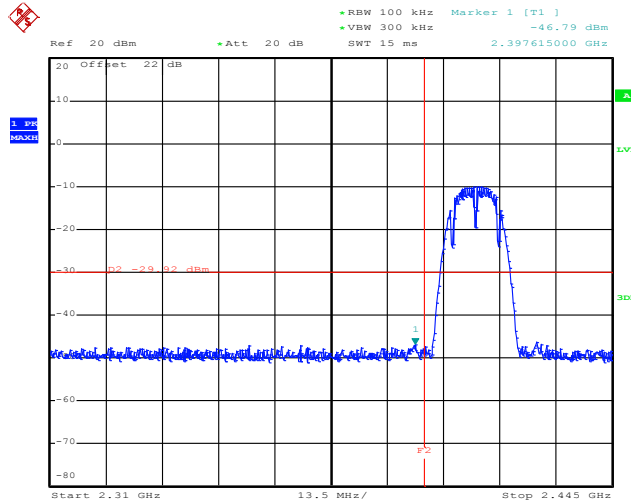

Date: 7.AUG.2012 08:04:44

802.11b

High Band Edge Plot on Channel 11

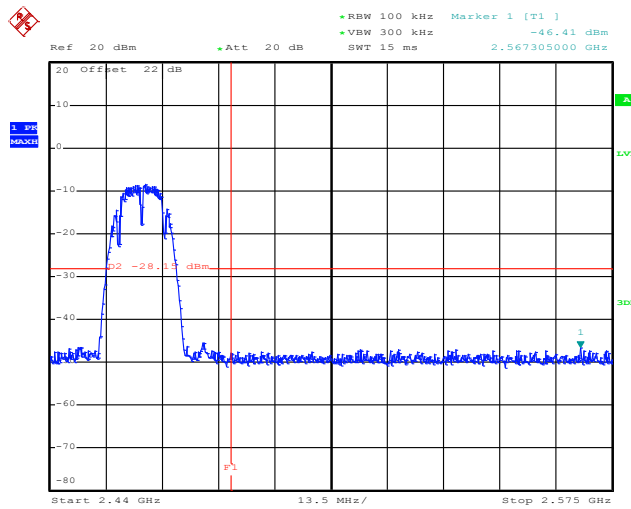

Date: 7.AUG.2012 08:10:17



Test Mode :	802.11g (SISO Ant. 0)	Temperature :	24~26°C
Test Band :	Low and High	Relative Humidity :	55~58%
Test Channel :	01 and 11	Test Engineer :	Bill Kuo

802.11g

Low Band Edge Plot on Channel 01

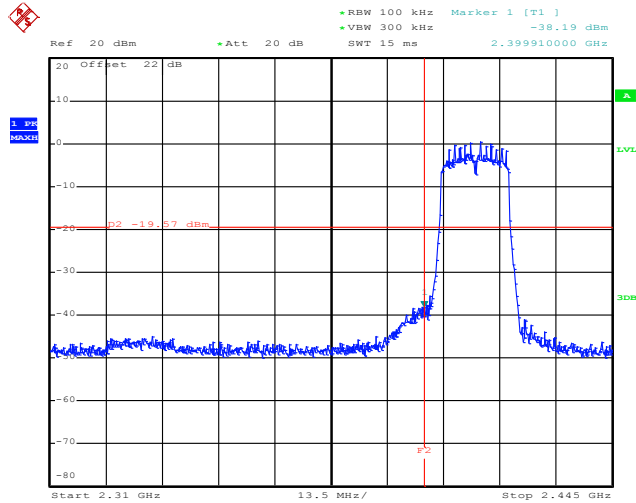

Date: 7.AUG.2012 05:25:08

802.11g

High Band Edge Plot on Channel 11

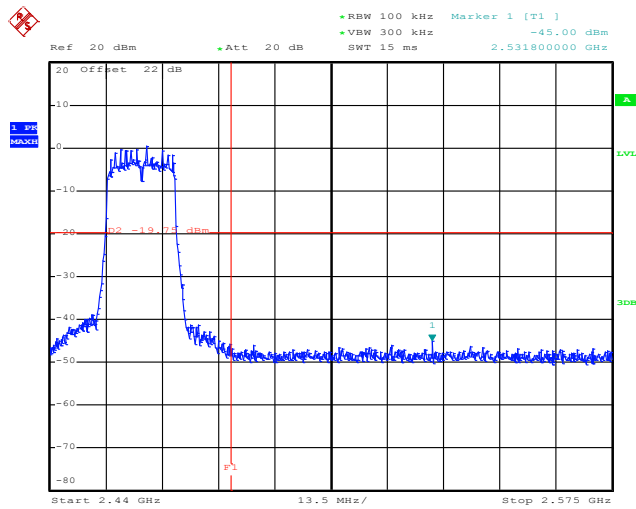

Date: 7.AUG.2012 05:32:04



Test Mode :	802.11g MIMO Ant. 0+1(0)	Temperature :	24~26°C
Test Band :	Low and High	Relative Humidity :	55~58%
Test Channel :	01 and 11	Test Engineer :	Bill Kuo

802.11g

Low Band Edge Plot on Channel 01

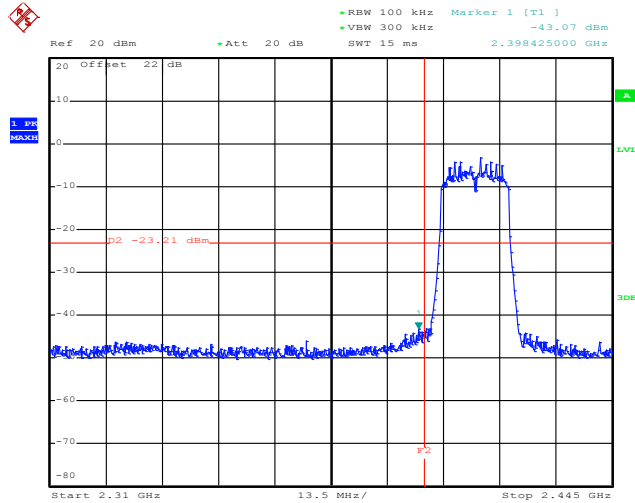

Date: 7.AUG.2012 05:43:59

802.11g

High Band Edge Plot on Channel 11

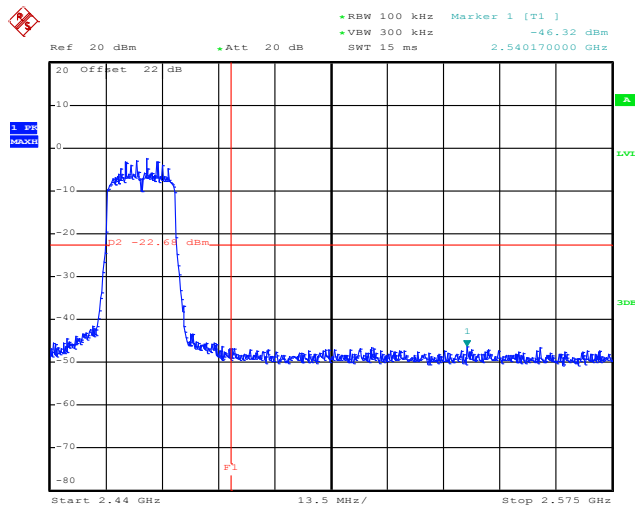

Date: 7.AUG.2012 05:36:22



Test Mode :	802.11g MIMO Ant. 0+1(1)	Temperature :	24~26°C
Test Band :	Low and High	Relative Humidity :	55~58%
Test Channel :	01 and 11	Test Engineer :	Bill Kuo

802.11g

Low Band Edge Plot on Channel 01

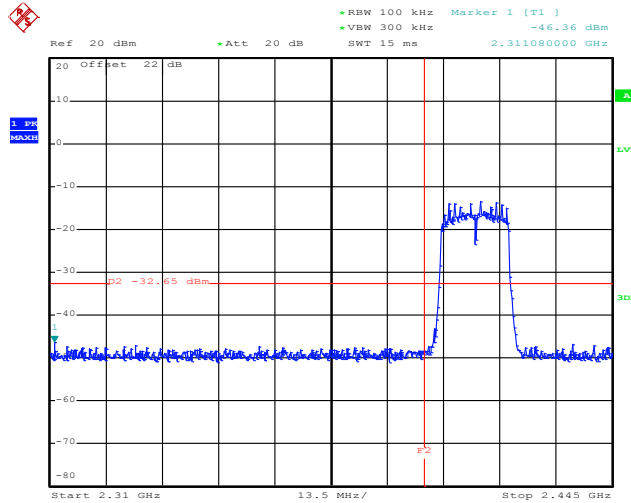

Date: 7.AUG.2012 08:01:05

802.11g

High Band Edge Plot on Channel 11

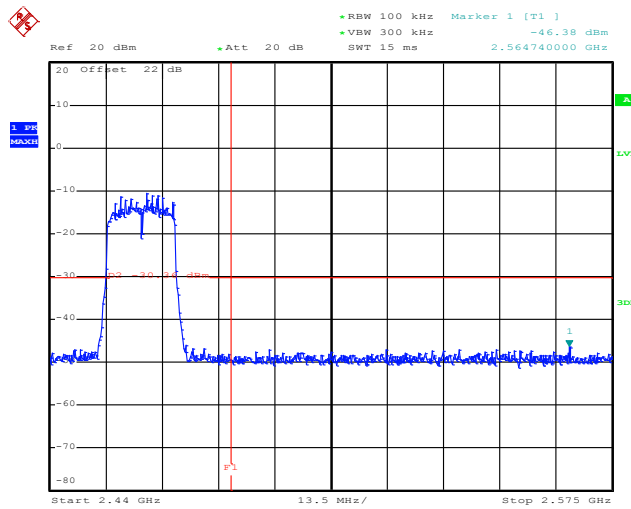

Date: 7.AUG.2012 07:52:34



Test Mode :	802.11n HT-20 SISO Ant. 0	Temperature :	24~26°C
Test Band :	Low and High	Relative Humidity :	55~58%
Test Channel :	01 and 11	Test Engineer :	Bill Kuo

802.11n HT-20

Low Band Edge Plot on Channel 01

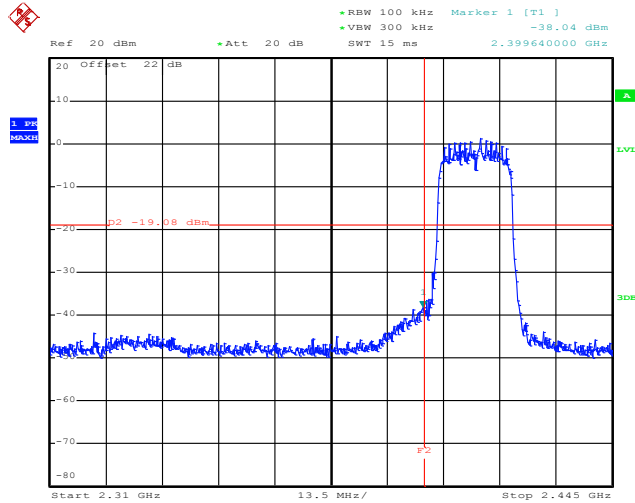

Date: 7.AUG.2012 05:50:45

802.11n HT-20

High Band Edge Plot on Channel 11

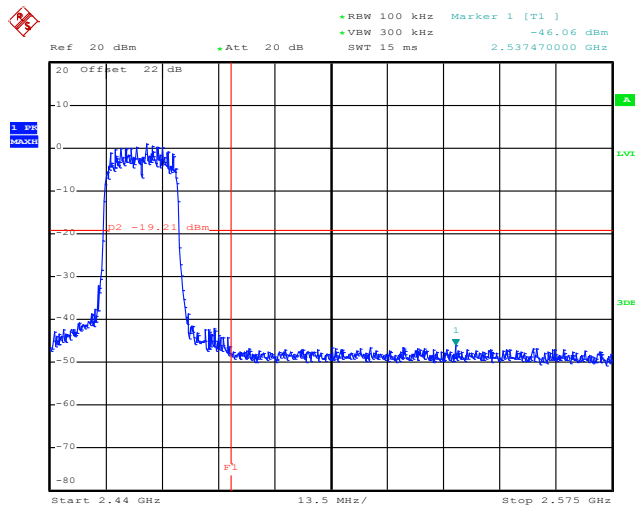

Date: 7.AUG.2012 05:59:42



Test Mode :	802.11n HT-20 MIMO Ant. 0+1(0)	Temperature :	24~26°C
Test Band :	Low and High	Relative Humidity :	55~58%
Test Channel :	01 and 11	Test Engineer :	Bill Kuo

802.11n HT-20

Low Band Edge Plot on Channel 01

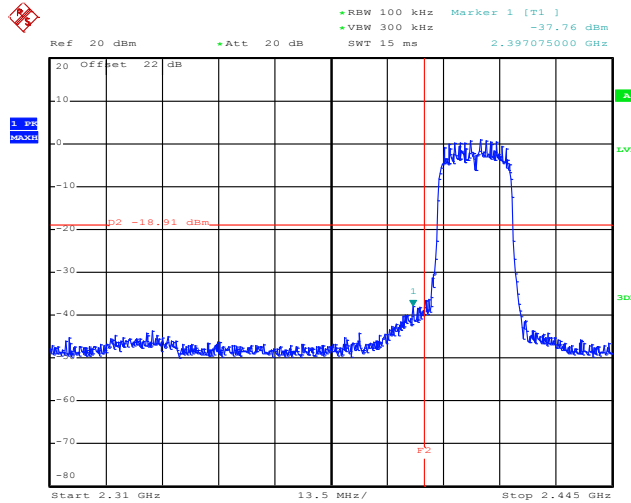

Date: 7.AUG.2012 06:10:47

802.11n HT-20

High Band Edge Plot on Channel 11

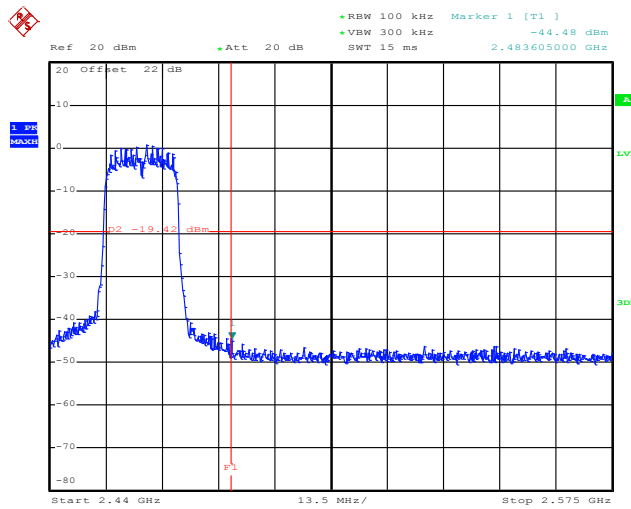

Date: 7.AUG.2012 06:03:48



Test Mode :	802.11n HT-20 MIMO Ant. 0+1(1)	Temperature :	24~26°C
Test Band :	Low and High	Relative Humidity :	55~58%
Test Channel :	01 and 11	Test Engineer :	Bill Kuo

802.11n HT-20

Low Band Edge Plot on Channel 01

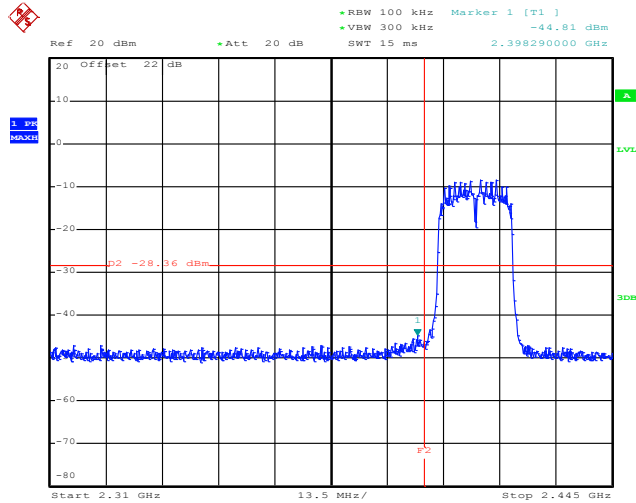

Date: 7.AUG.2012 07:38:59

802.11n HT-20

High Band Edge Plot on Channel 11

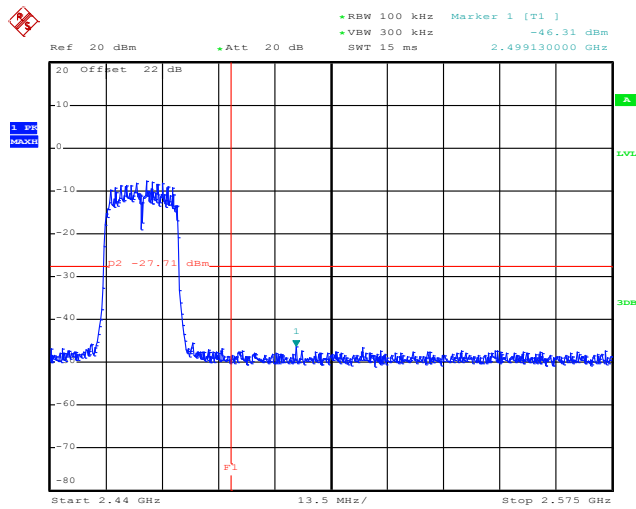

Date: 7.AUG.2012 07:46:44



Test Mode :	802.11n HT-40 SISO Ant. 0	Temperature :	24~26°C
Test Band :	Low and High	Relative Humidity :	55~58%
Test Channel :	03 and 09	Test Engineer :	Bill Kuo

802.11n HT-40

Low Band Edge Plot on Channel 03

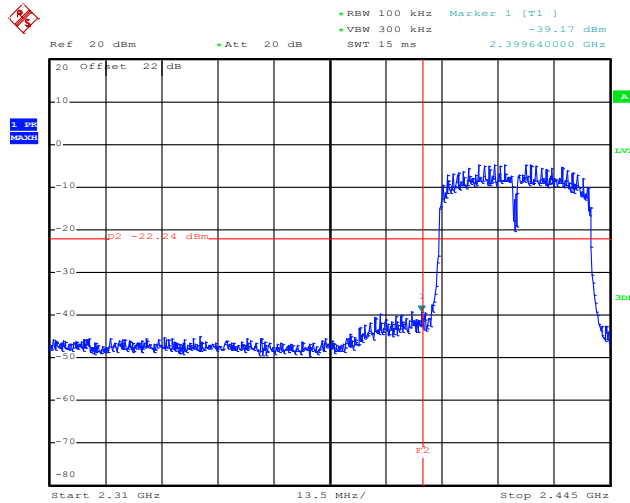

Date: 6.SEP.2012 22:51:55

802.11n HT-40

High Band Edge Plot on Channel 09

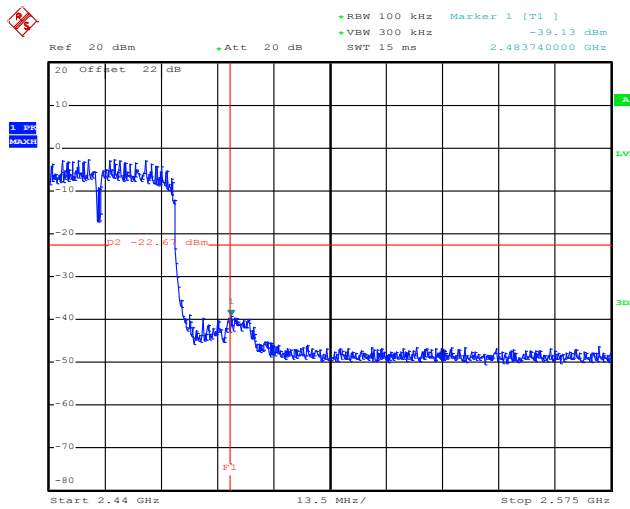

Date: 7.AUG.2012 06:55:11



Test Mode :	802.11n HT-40 MIMO Ant. 0+1(0)	Temperature :	24~26°C
Test Band :	Low and High	Relative Humidity :	55~58%
Test Channel :	03 and 09	Test Engineer :	Bill Kuo

802.11n HT-40

Low Band Edge Plot on Channel 03

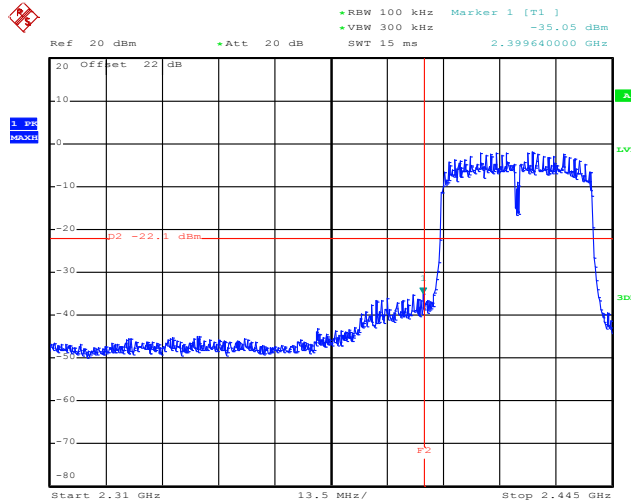

Date: 7.AUG.2012 07:08:39

802.11n HT-40

High Band Edge Plot on Channel 09

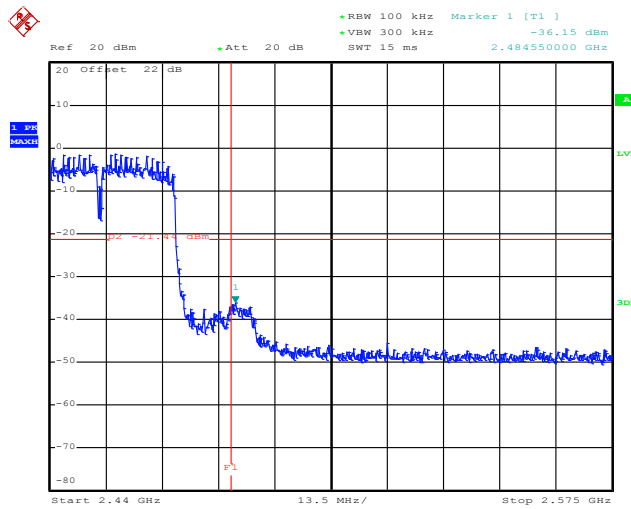

Date: 7.AUG.2012 07:00:10



Test Mode :	802.11n HT-40 MIMO Ant. 0+1(1)	Temperature :	24~26°C
Test Band :	Low and High	Relative Humidity :	55~58%
Test Channel :	03 and 09	Test Engineer :	Bill Kuo

802.11n HT-40

Low Band Edge Plot on Channel 03

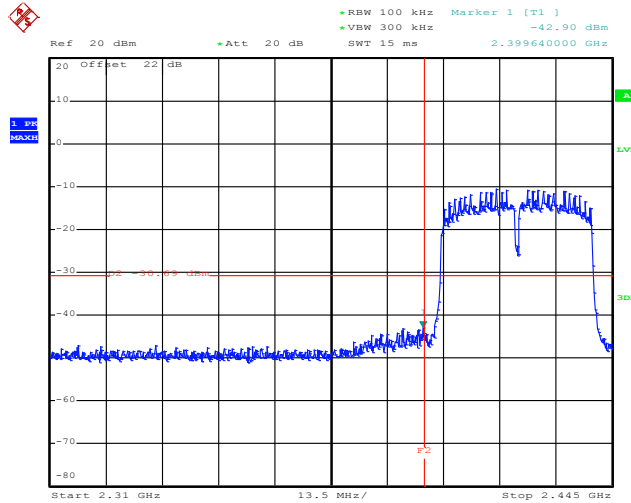

Date: 7.AUG.2012 07:13:28

802.11n HT-40

High Band Edge Plot on Channel 09

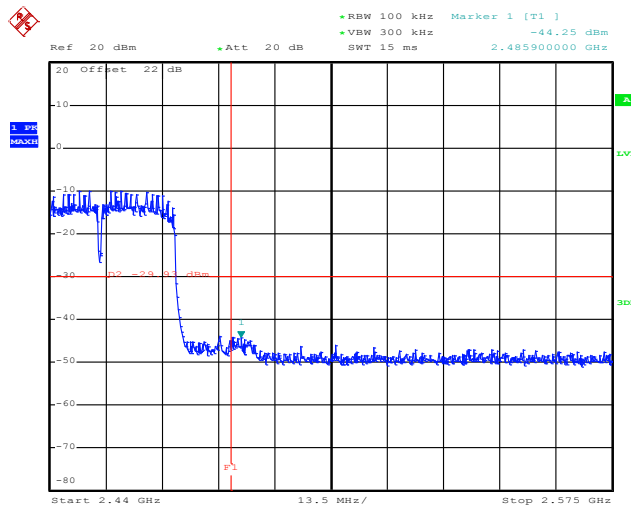

Date: 7.AUG.2012 07:29:17

3.4.6 Test Result of Conducted Spurious Emission

Test Mode :	802.11b SISO Ant. 0	Temperature :	24~26°C
Test Band :	30MHz-3GHz and 2G-25GHz	Relative Humidity :	55~58%
Test Channel :	01, 06, 11	Test Engineer :	Bill Kuo

802.11b 30 MHz~3 GHz

Conducted Spurious Emission Plot on Channel 01

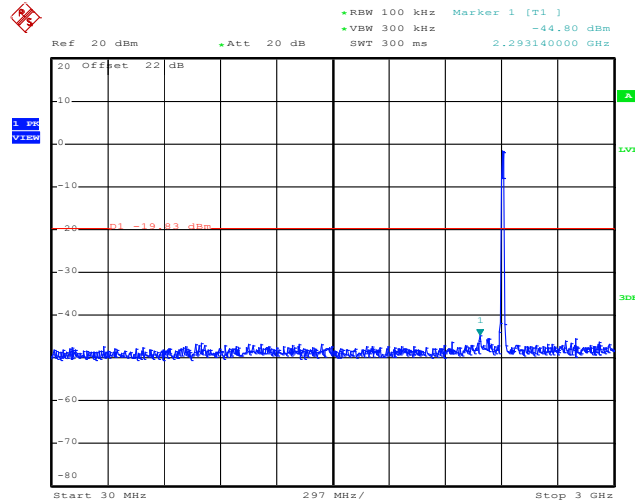

Date: 7.AUG.2012 04:56:21

802.11b 2 GHz~25 GHz

Conducted Spurious Emission Plot on Channel 01

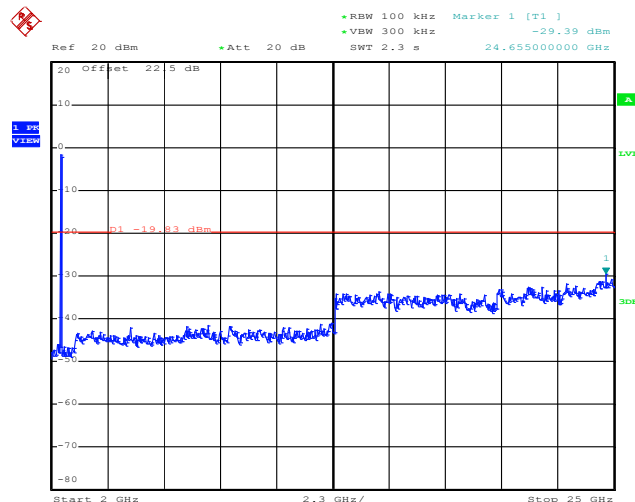

Date: 7.AUG.2012 04:56:40



802.11b 30 MHz~3 GHz

Conducted Spurious Emission Plot on Channel 06

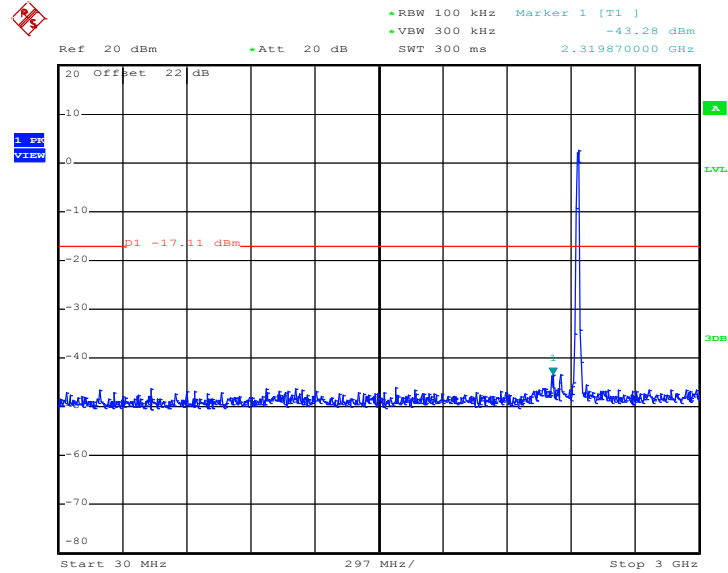

Date: 7.AUG.2012 05:00:51

802.11b 2 GHz~25 GHz

Conducted Spurious Emission Plot on Channel 06

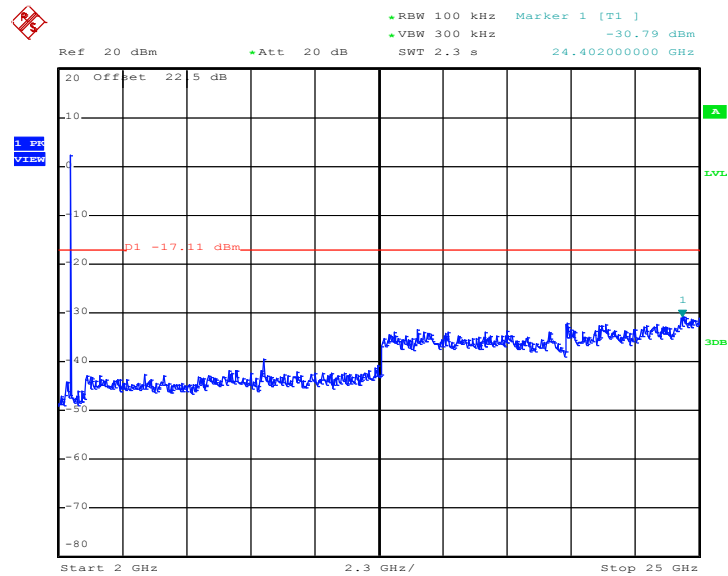

Date: 7.AUG.2012 05:01:10



802.11b 30 MHz~3 GHz

Conducted Spurious Emission Plot on Channel 11

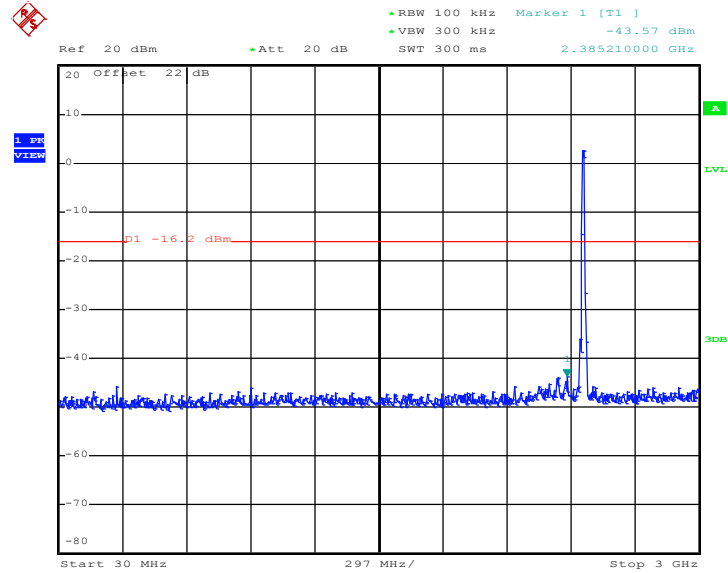

Date: 7.AUG.2012 05:04:00

802.11b 2 GHz~25 GHz

Conducted Spurious Emission Plot on Channel 11

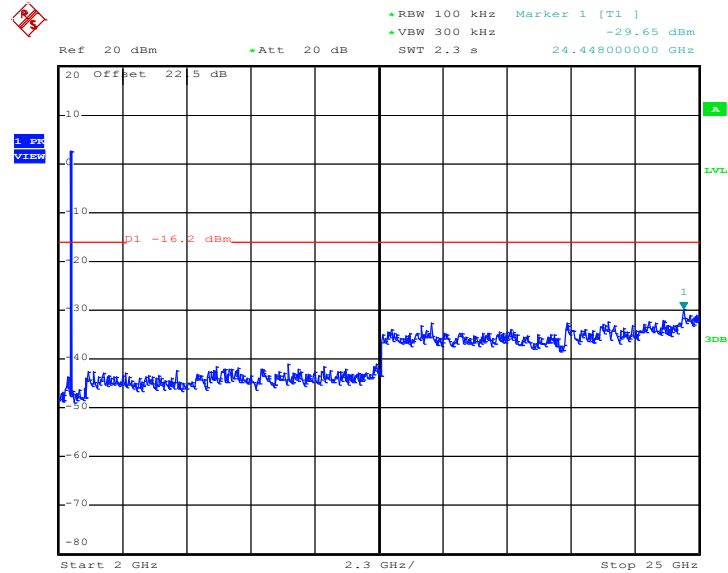

Date: 7.AUG.2012 05:04:19



Test Mode :	802.11b MIMO Ant. 0+1(0)	Temperature :	24~26°C
Test Band :	30MHz-3GHz and 2G-25GHz	Relative Humidity :	55~58%
Test Channel :	01, 06, 11	Test Engineer :	Bill Kuo

802.11b 30 MHz~3 GHz

Conducted Spurious Emission Plot on Channel 01

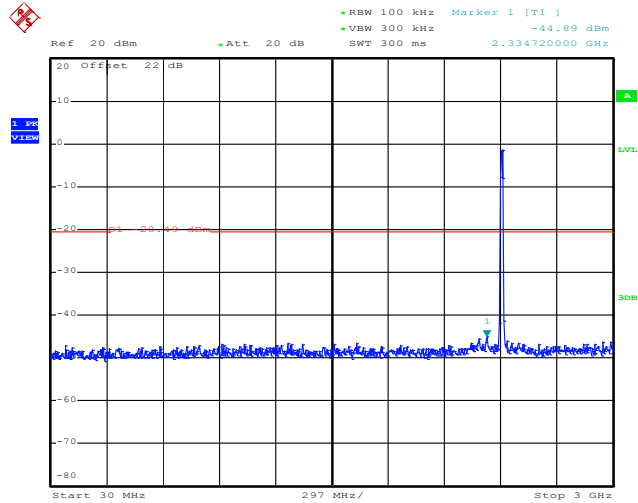

Date: 7.AUG.2012 05:17:41

802.11b 2 GHz~25 GHz

Conducted Spurious Emission Plot on Channel 01

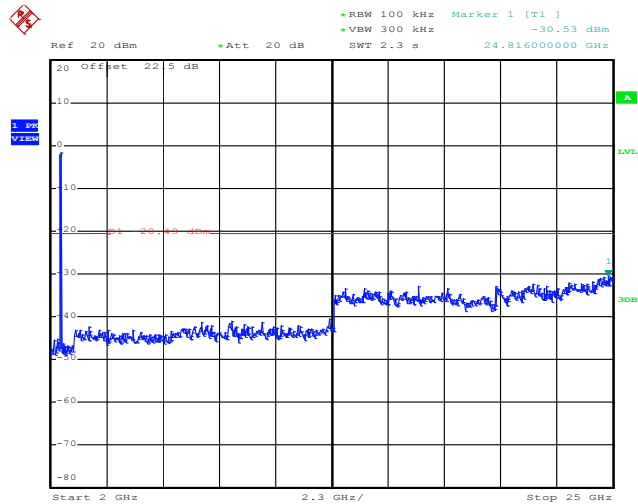

Date: 7.AUG.2012 05:18:00



802.11b 30 MHz~3 GHz

Conducted Spurious Emission Plot on Channel 06

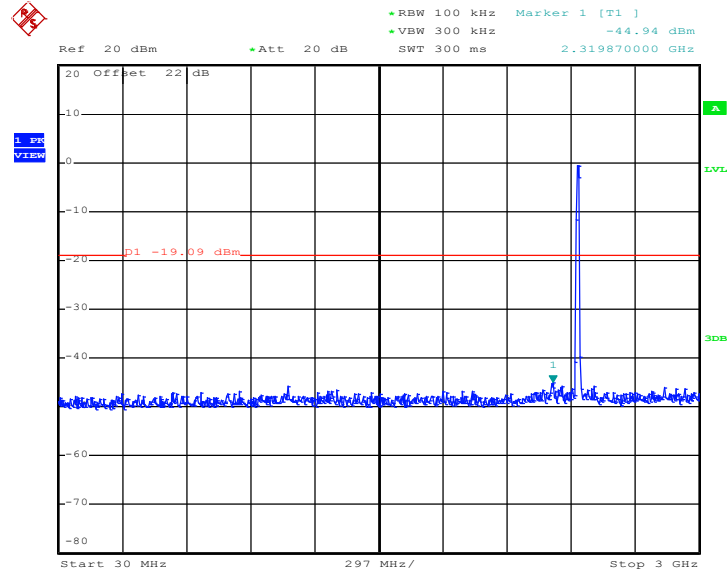

Date: 7.AUG.2012 05:14:11

802.11b 2 GHz~25 GHz

Conducted Spurious Emission Plot on Channel 06

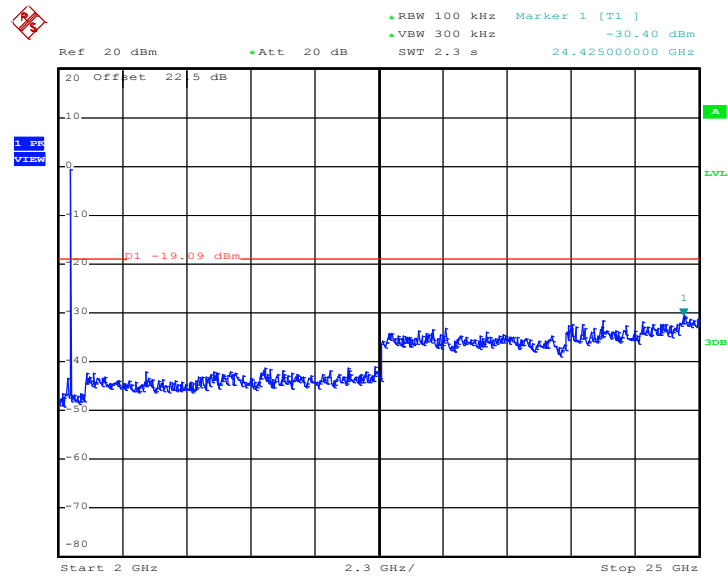

Date: 7.AUG.2012 05:14:29



802.11b 30 MHz~3 GHz

Conducted Spurious Emission Plot on Channel 11

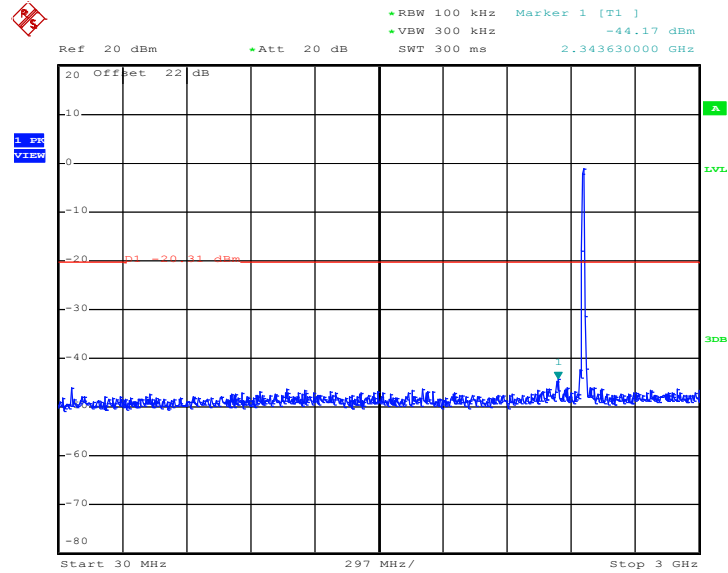

Date: 7.AUG.2012 05:10:16

802.11b 2 GHz~25 GHz

Conducted Spurious Emission Plot on Channel 11

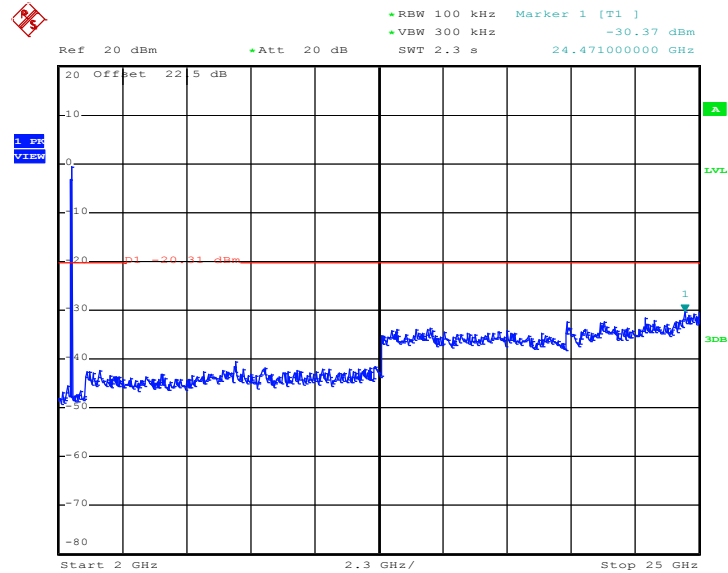

Date: 7.AUG.2012 05:10:35



Test Mode :	802.11b MIMO Ant. 0+1(1)	Temperature :	24~26°C
Test Band :	30MHz-3GHz and 2G-25GHz	Relative Humidity :	55~58%
Test Channel :	01, 06, 11	Test Engineer :	Bill Kuo

802.11b 30 MHz~3 GHz

Conducted Spurious Emission Plot on Channel 01

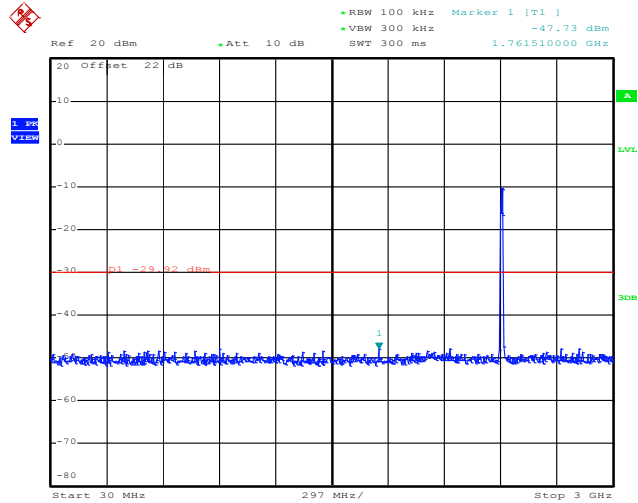

Date: 7.AUG.2012 08:02:25

802.11b 2 GHz~25 GHz

Conducted Spurious Emission Plot on Channel 01

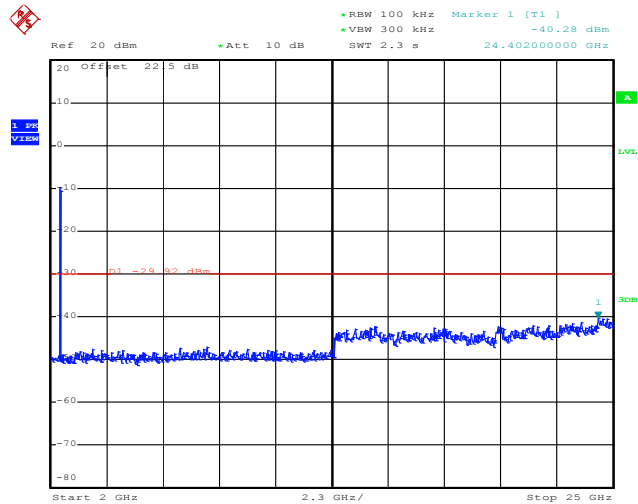

Date: 7.AUG.2012 08:02:44



802.11b 30 MHz~3 GHz

Conducted Spurious Emission Plot on Channel 06

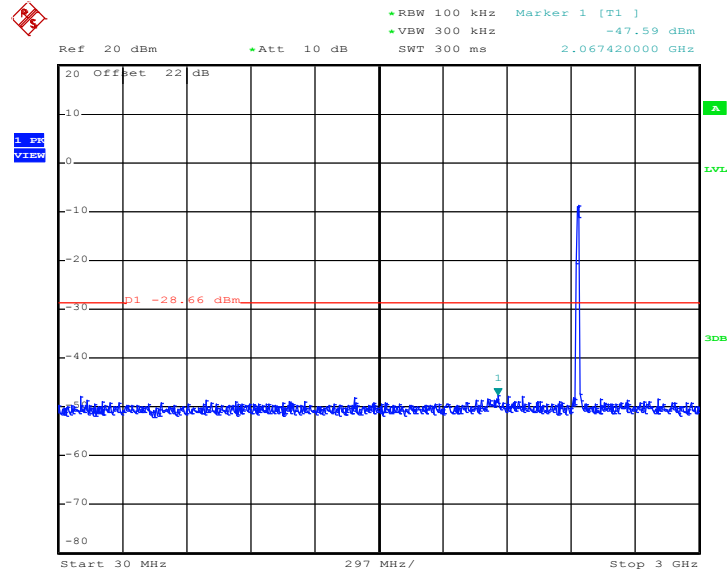

Date: 7.AUG.2012 08:05:06

802.11b 2 GHz~25 GHz

Conducted Spurious Emission Plot on Channel 06

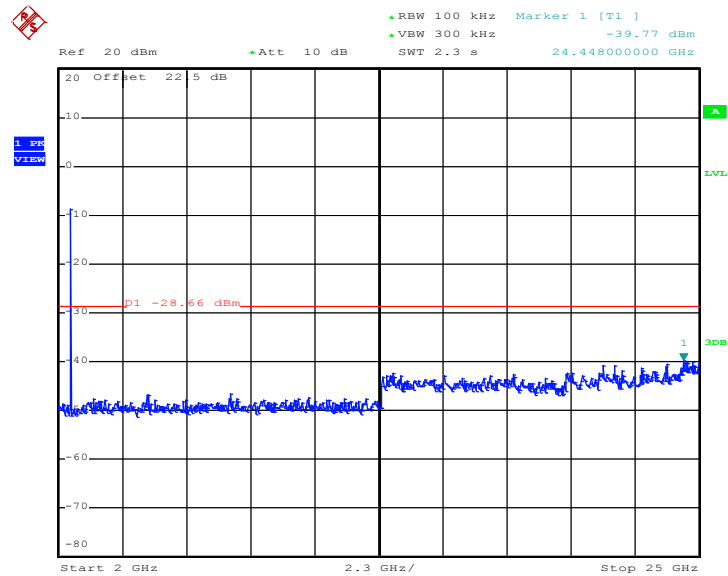

Date: 7.AUG.2012 08:05:25



802.11b 30 MHz~3 GHz

Conducted Spurious Emission Plot on Channel 11

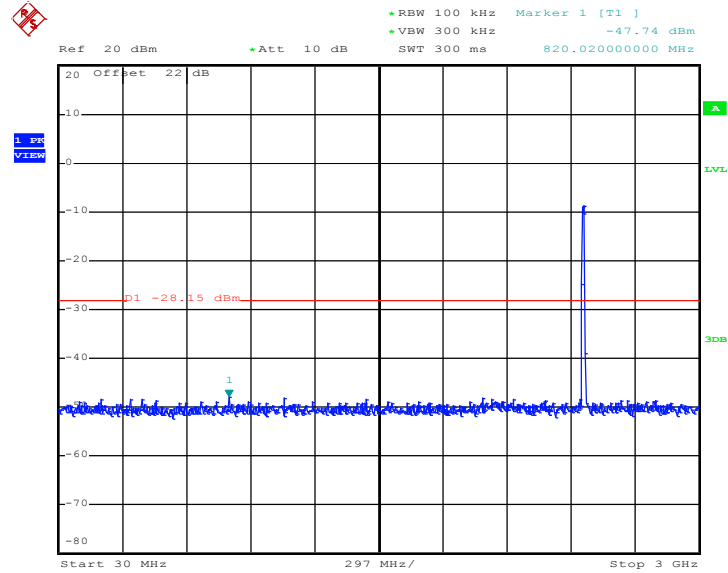

Date: 7.AUG.2012 08:07:55

802.11b 2 GHz~25 GHz

Conducted Spurious Emission Plot on Channel 11

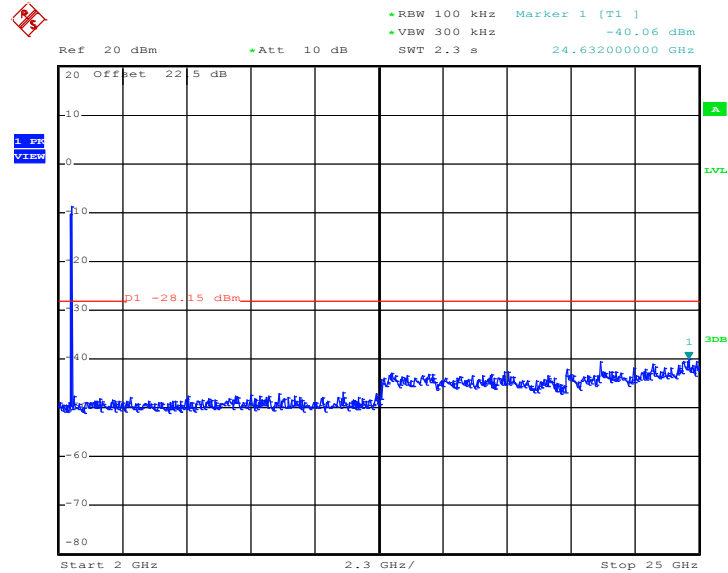

Date: 7.AUG.2012 08:08:14



Test Mode :	802.11g SISO Ant. 0	Temperature :	24~26°C
Test Band :	30MHz-3GHz and 2G-25GHz	Relative Humidity :	55~58%
Test Channel :	01, 06, 11	Test Engineer :	Bill Kuo

802.11g 30 MHz~3 GHz

Conducted Spurious Emission Plot on Channel 01

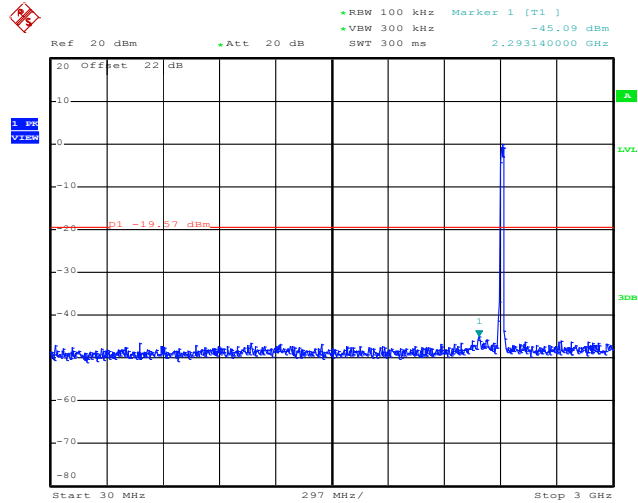

Date: 7.AUG.2012 05:22:55

802.11g 2 GHz~25 GHz

Conducted Spurious Emission Plot on Channel 01

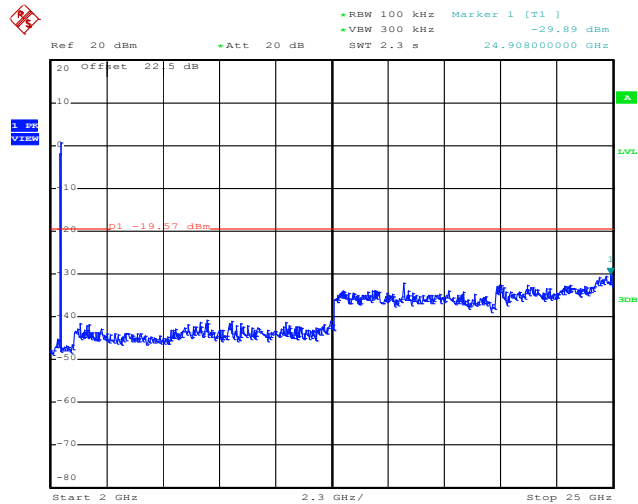

Date: 7.AUG.2012 05:23:14



802.11g 30 MHz~3 GHz

Conducted Spurious Emission Plot on Channel 11

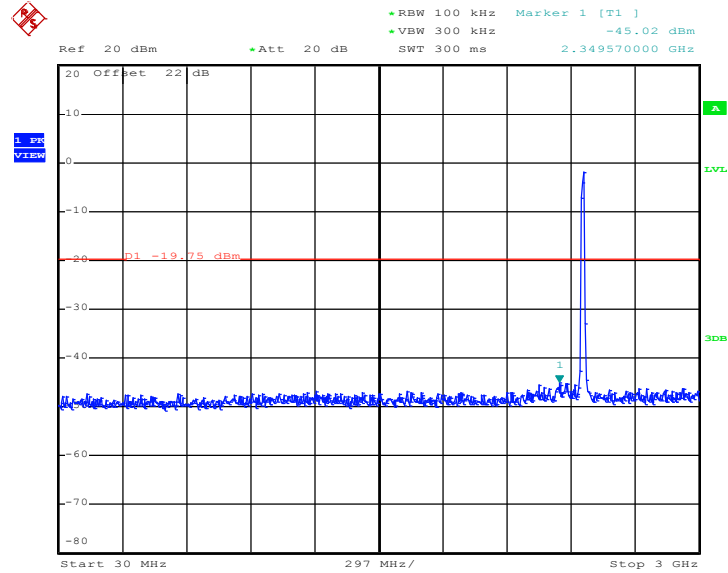

Date: 7.AUG.2012 05:29:49

802.11g 2 GHz~25 GHz

Conducted Spurious Emission Plot on Channel 11

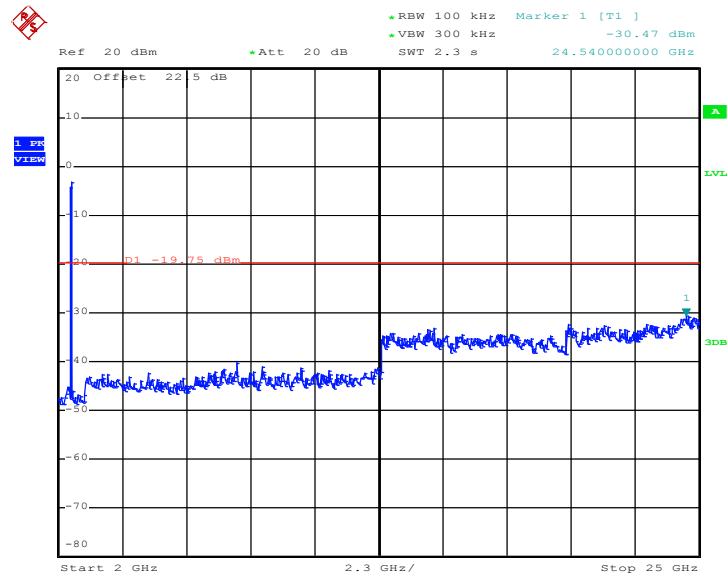

Date: 7.AUG.2012 05:30:08



Test Mode :	802.11g MIMO Ant. 0+1(0)	Temperature :	24~26°C
Test Band :	30MHz-3GHz and 2G-25GHz	Relative Humidity :	55~58%
Test Channel :	01, 06, 11	Test Engineer :	Bill Kuo

802.11g 30 MHz~3 GHz

Conducted Spurious Emission Plot on Channel 01

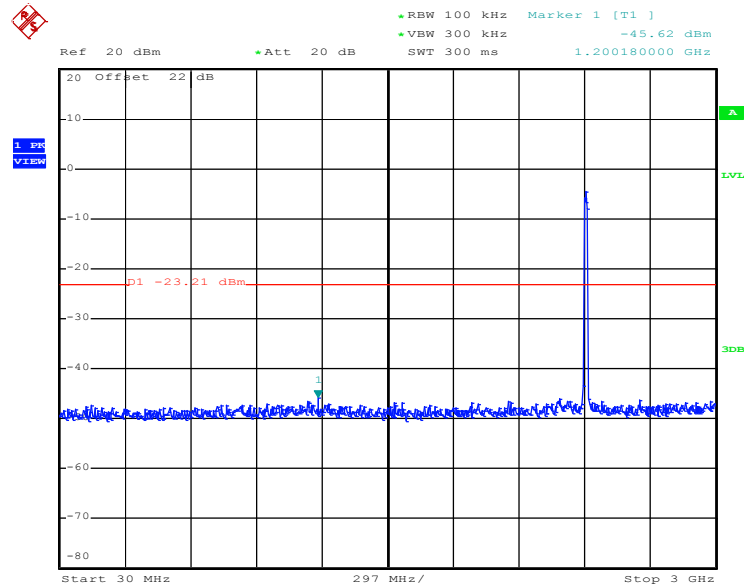

Date: 7.AUG.2012 05:41:41

802.11g 2 GHz~25 GHz

Conducted Spurious Emission Plot on Channel 01

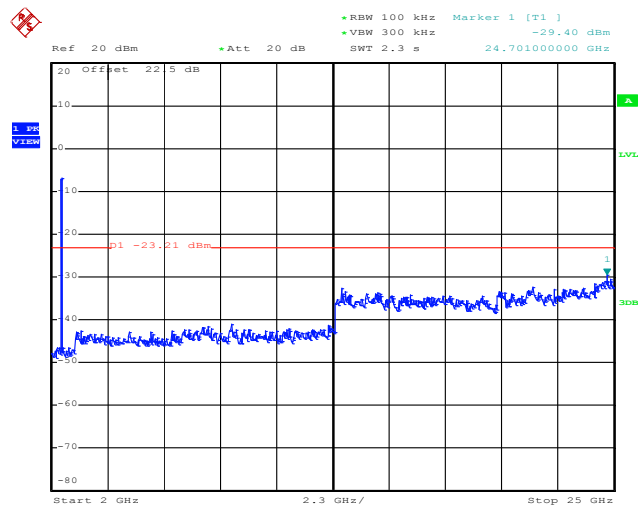

Date: 7.AUG.2012 05:42:00



802.11g 30 MHz~3 GHz

Conducted Spurious Emission Plot on Channel 06

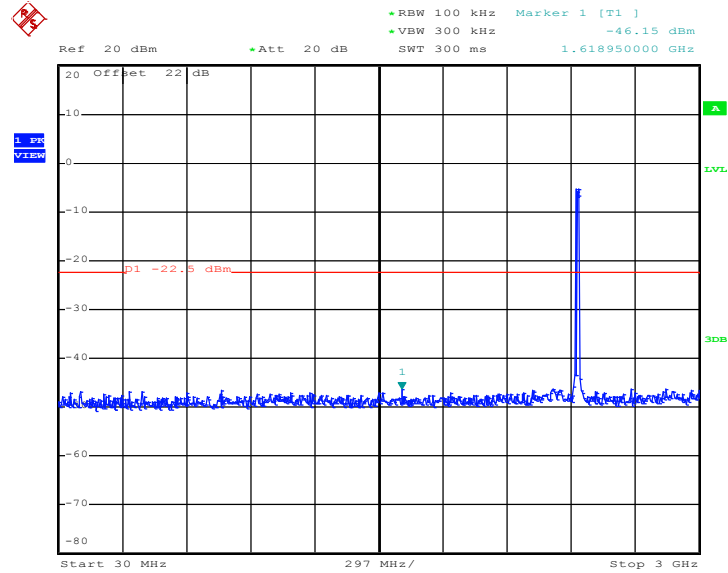

Date: 7.AUG.2012 05:37:56

802.11g 2 GHz~25 GHz

Conducted Spurious Emission Plot on Channel 06

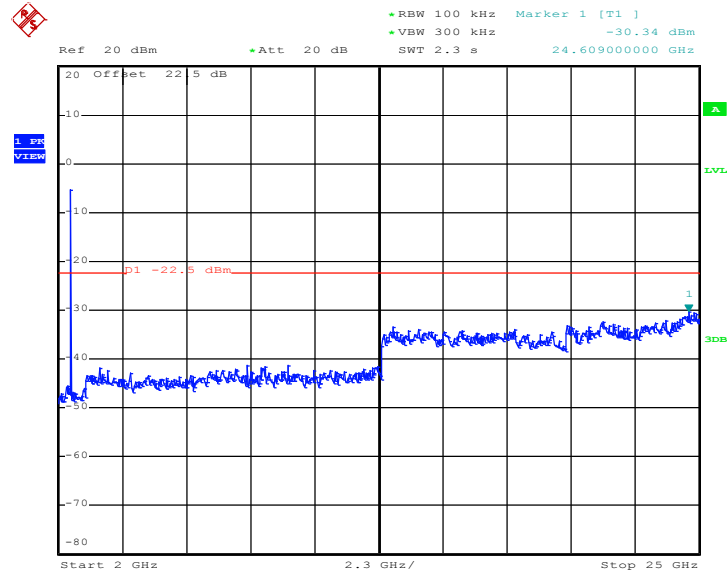

Date: 7.AUG.2012 05:38:14



802.11g 30 MHz~3 GHz

Conducted Spurious Emission Plot on Channel 11

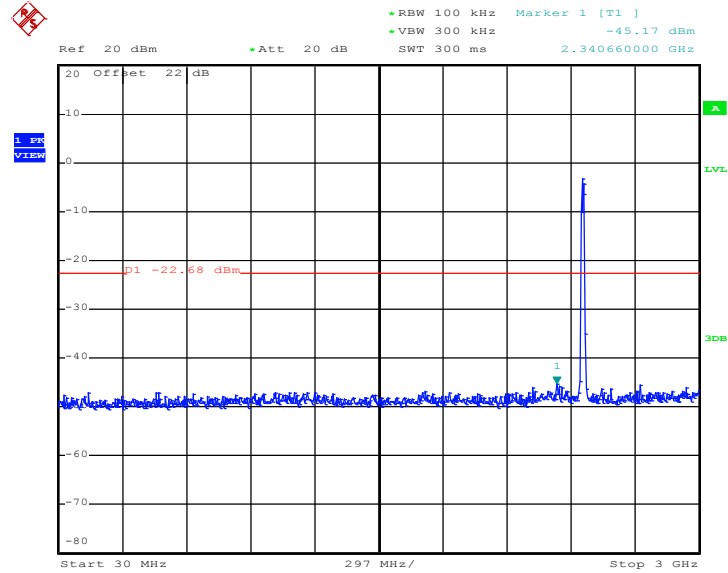

Date: 7.AUG.2012 05:34:20

802.11g 2 GHz~25 GHz

Conducted Spurious Emission Plot on Channel 11

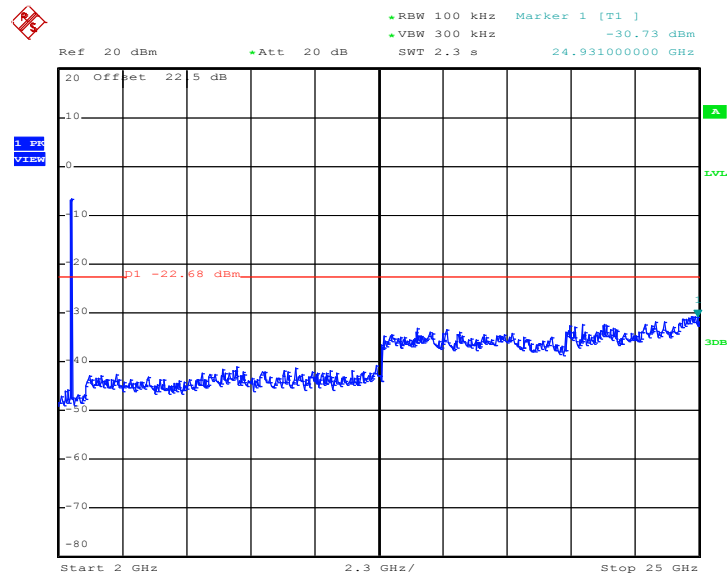

Date: 7.AUG.2012 05:34:39



Test Mode :	802.11g MIMO Ant. 0+1(1)	Temperature :	24~26°C
Test Band :	30MHz-3GHz and 2G-25GHz	Relative Humidity :	55~58%
Test Channel :	01, 06, 11	Test Engineer :	Bill Kuo

802.11g 30 MHz~3 GHz

Conducted Spurious Emission Plot on Channel 01

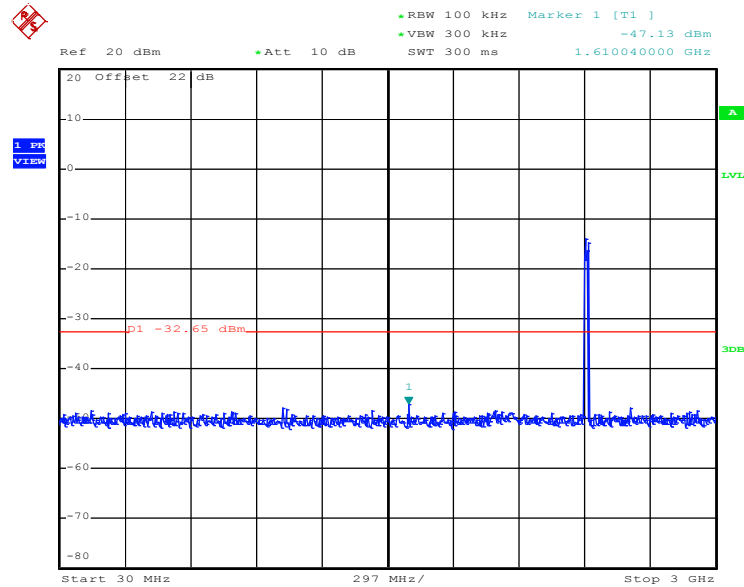

Date: 7.AUG.2012 07:58:47

802.11g 2 GHz~25 GHz

Conducted Spurious Emission Plot on Channel 01

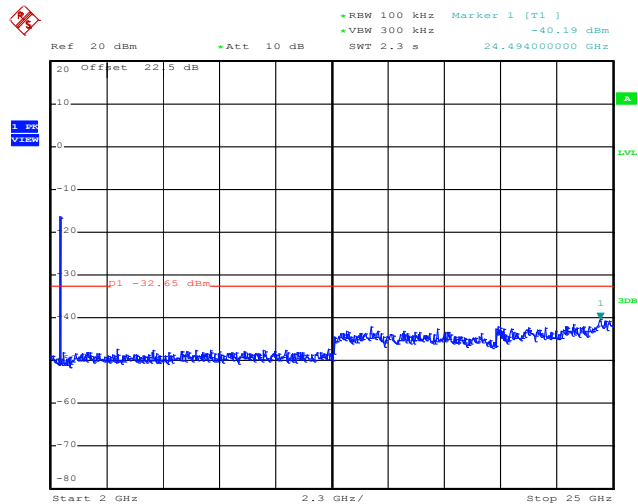

Date: 7.AUG.2012 07:59:06



802.11g 30 MHz~3 GHz

Conducted Spurious Emission Plot on Channel 06

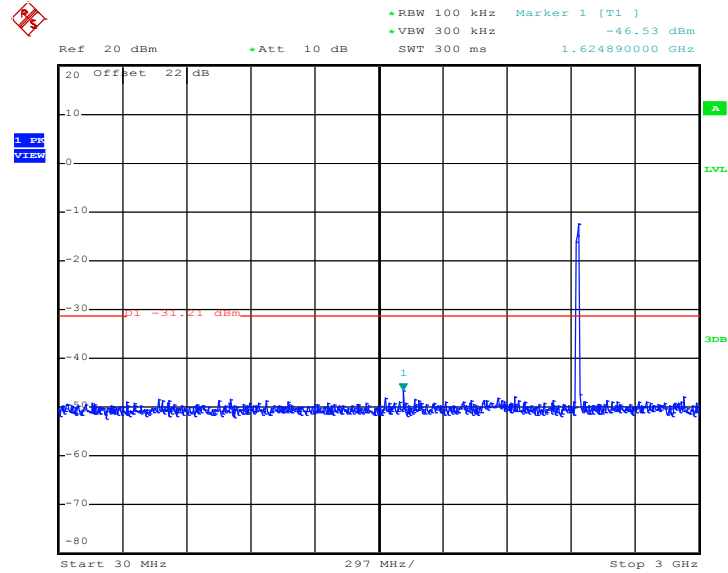

Date: 7.AUG.2012 07:55:40

802.11g 2 GHz~25 GHz

Conducted Spurious Emission Plot on Channel 06

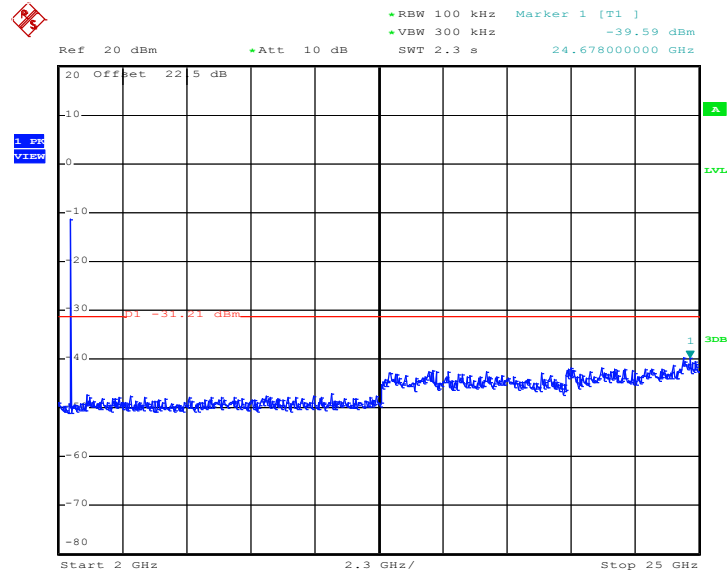

Date: 7.AUG.2012 07:55:59



802.11g 30 MHz~3 GHz

Conducted Spurious Emission Plot on Channel 11

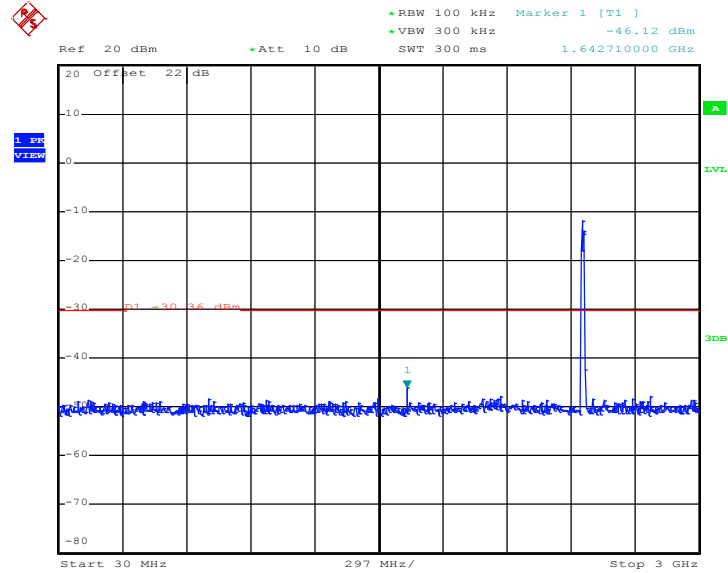

Date: 7.AUG.2012 07:50:54

802.11g 2 GHz~25 GHz

Conducted Spurious Emission Plot on Channel 11

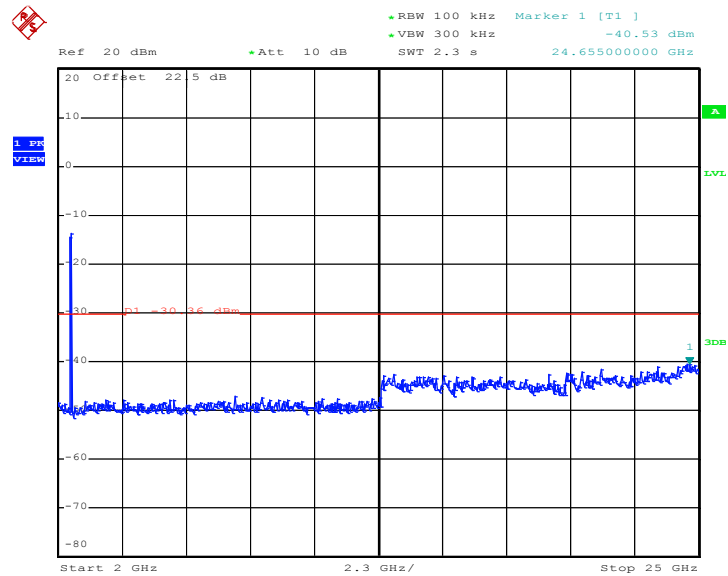

Date: 7.AUG.2012 07:51:13



Test Mode :	802.11n HT-20 SISO Ant. 0	Temperature :	24~26°C
Test Band :	30MHz-3GHz and 2G-25GHz	Relative Humidity :	55~58%
Test Channel :	01, 06, 11	Test Engineer :	Bill Kuo

802.11n HT-20 30 MHz~3 GHz

Conducted Spurious Emission Plot on Channel 01

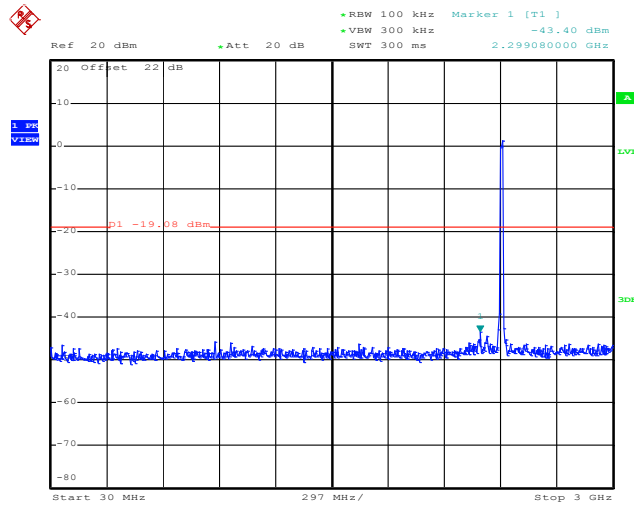

Date: 7.AUG.2012 05:49:00

802.11n HT-20 2 GHz~25 GHz

Conducted Spurious Emission Plot on Channel 01

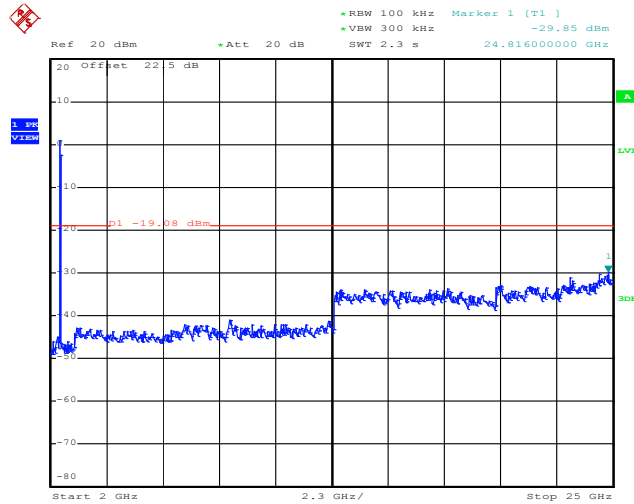

Date: 7.AUG.2012 05:49:18



802.11n HT-20 30 MHz~3 GHz

Conducted Spurious Emission Plot on Channel 06

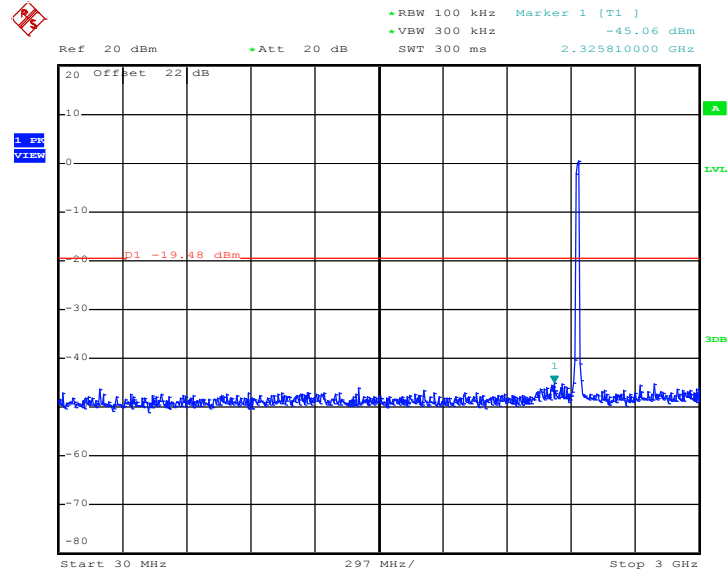

Date: 7.AUG.2012 05:53:34

802.11n HT-20 2 GHz~25 GHz

Conducted Spurious Emission Plot on Channel 06

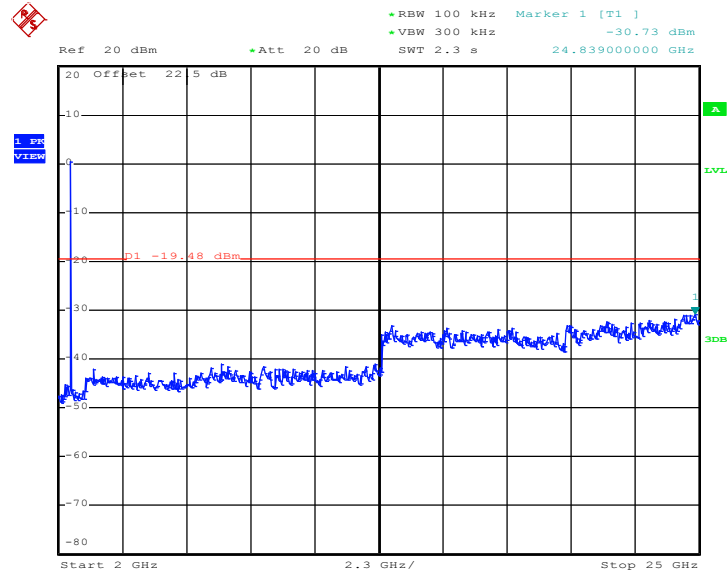

Date: 7.AUG.2012 05:53:53



802.11n HT-20 30 MHz~3 GHz

Conducted Spurious Emission Plot on Channel 11

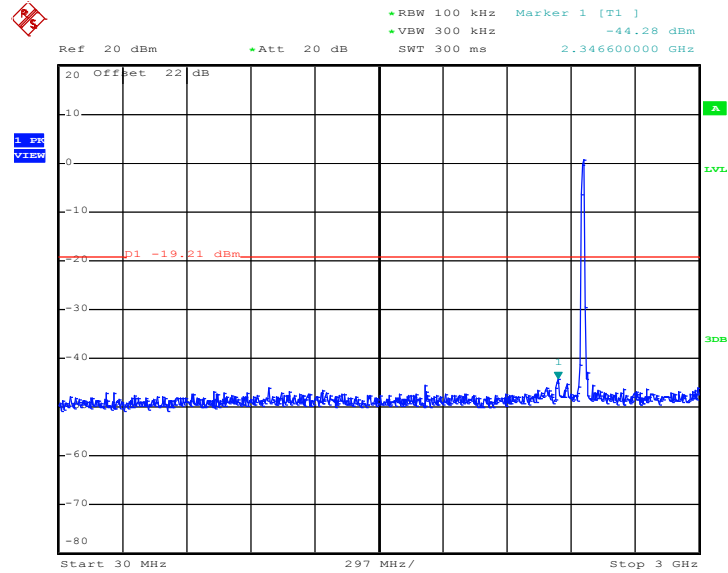

Date: 7.AUG.2012 05:57:27

802.11n HT-20 2 GHz~25 GHz

Conducted Spurious Emission Plot on Channel 11

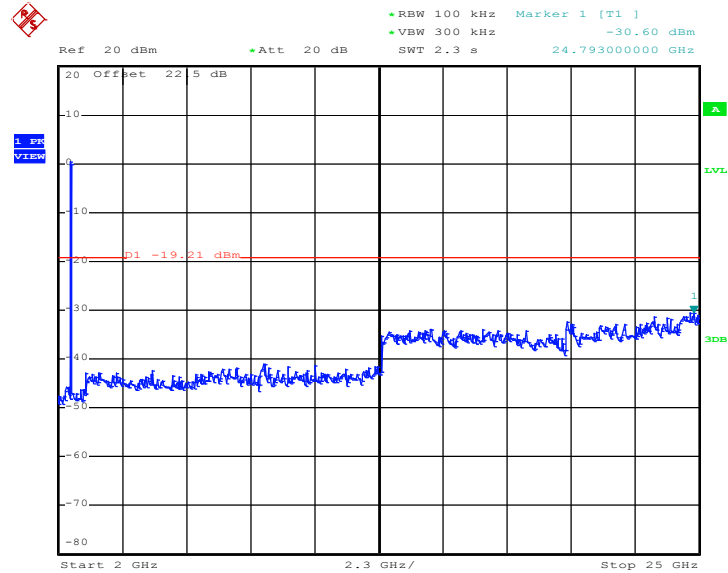

Date: 7.AUG.2012 05:57:45



Test Mode :	802.11n HT-20 MIMO Ant. 0+1(0)	Temperature :	24~26°C
Test Band :	30MHz-3GHz and 2G-25GHz	Relative Humidity :	55~58%
Test Channel :	01, 06, 11	Test Engineer :	Bill Kuo

802.11n HT-20 30 MHz~3 GHz

Conducted Spurious Emission Plot on Channel 01

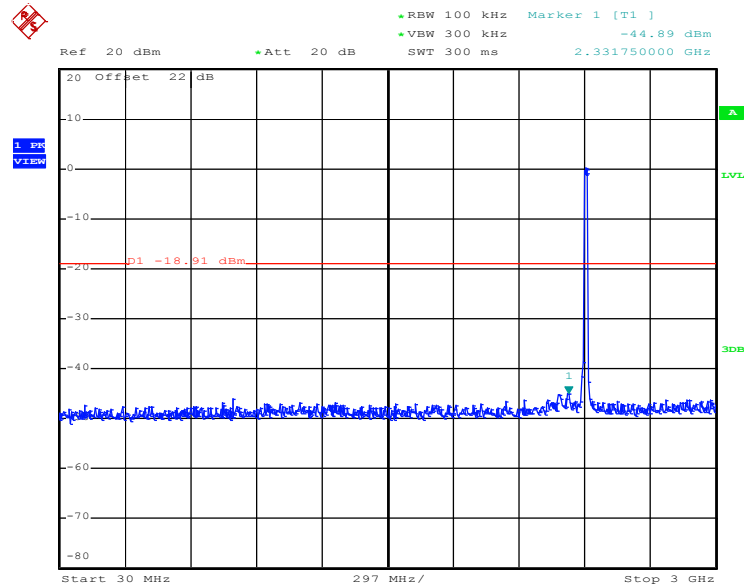

Date: 7.AUG.2012 06:08:28

802.11n HT-20 2 GHz~25 GHz

Conducted Spurious Emission Plot on Channel 01

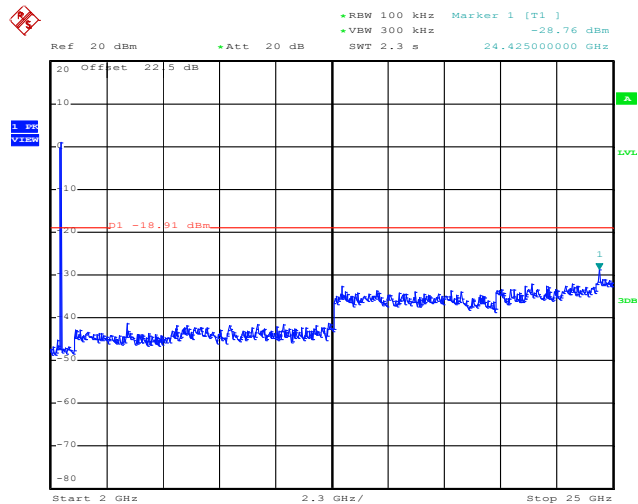

Date: 7.AUG.2012 06:08:46



802.11n HT-20 30 MHz~3 GHz

Conducted Spurious Emission Plot on Channel 06

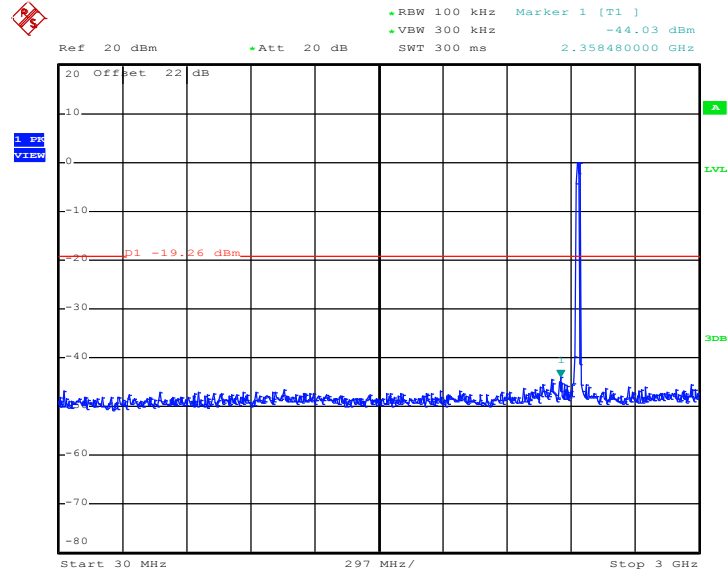

Date: 7.AUG.2012 06:04:55

802.11n HT-20 2 GHz~25 GHz

Conducted Spurious Emission Plot on Channel 06

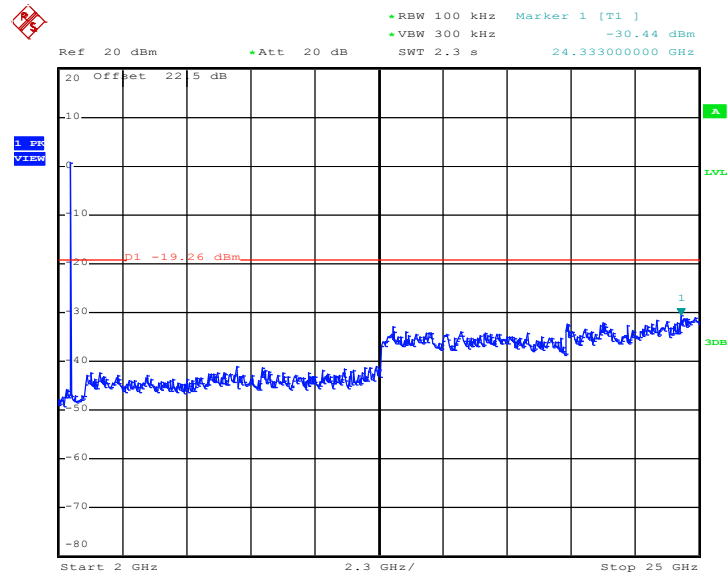

Date: 7.AUG.2012 06:05:13



802.11n HT-20 30 MHz~3 GHz

Conducted Spurious Emission Plot on Channel 11

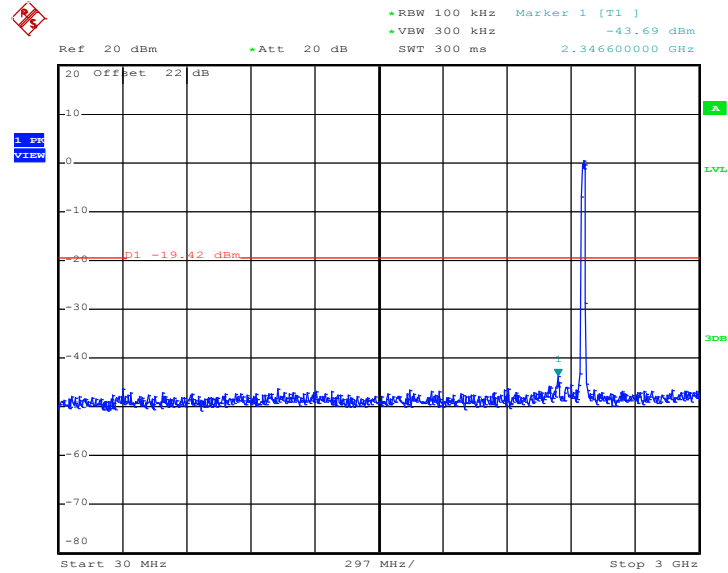

Date: 7.AUG.2012 06:01:29

802.11n HT-20 2 GHz~25 GHz

Conducted Spurious Emission Plot on Channel 11

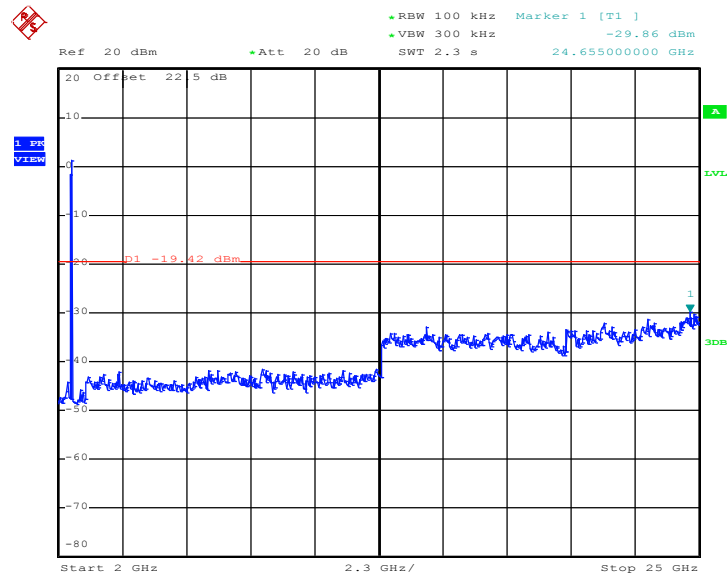

Date: 7.AUG.2012 06:01:48



Test Mode :	802.11n HT-20 MIMO Ant. 0+1(1)	Temperature :	24~26°C
Test Band :	30MHz-3GHz and 2G-25GHz	Relative Humidity :	55~58%
Test Channel :	01, 06, 11	Test Engineer :	Bill Kuo

802.11n HT-20 30 MHz~3 GHz

Conducted Spurious Emission Plot on Channel 01

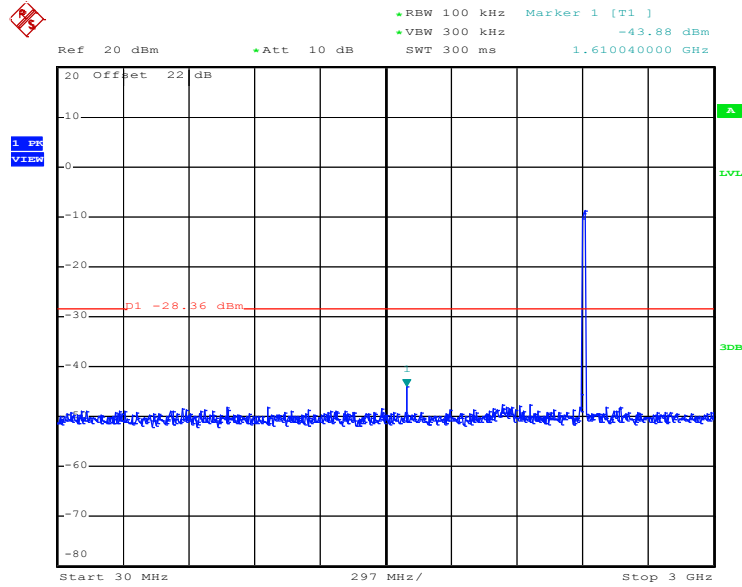

Date: 7.AUG.2012 07:36:45

802.11n HT-20 2 GHz~25 GHz

Conducted Spurious Emission Plot on Channel 01

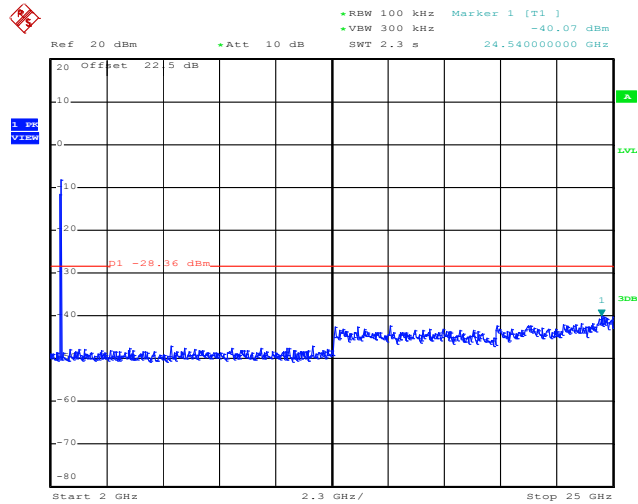

Date: 7.AUG.2012 07:37:04



802.11n HT-20 30 MHz~3 GHz

Conducted Spurious Emission Plot on Channel 06

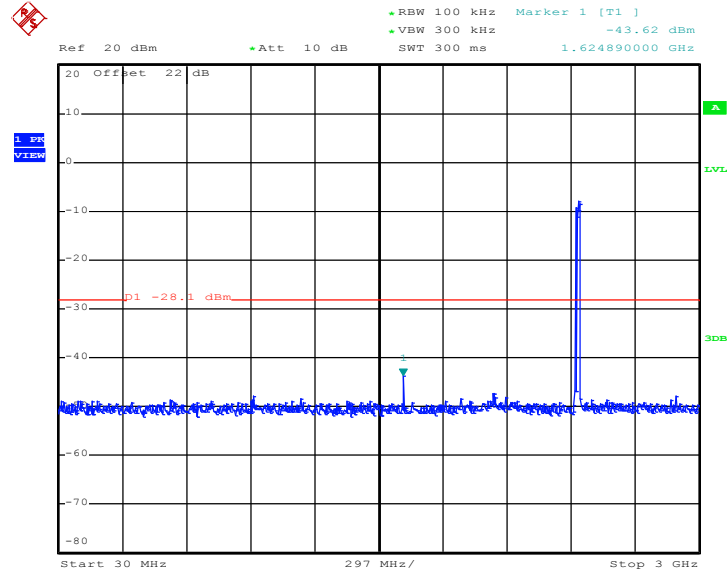

Date: 7.AUG.2012 07:40:35

802.11n HT-20 2 GHz~25 GHz

Conducted Spurious Emission Plot on Channel 06

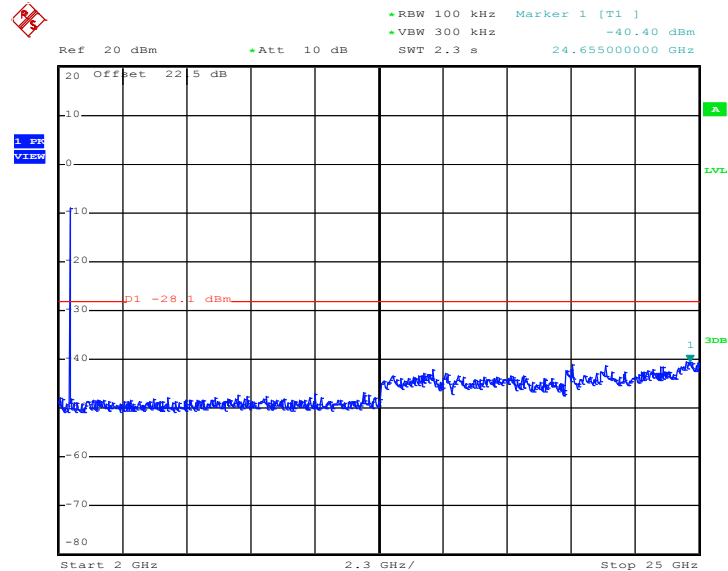

Date: 7.AUG.2012 07:40:54



802.11n HT-20 30 MHz~3 GHz

Conducted Spurious Emission Plot on Channel 11

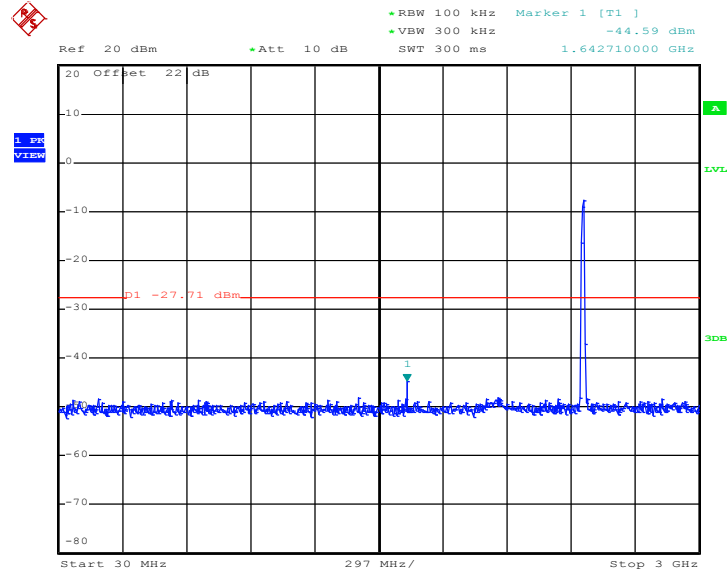

Date: 7.AUG.2012 07:45:27

802.11n HT-20 2 GHz~25 GHz

Conducted Spurious Emission Plot on Channel 11

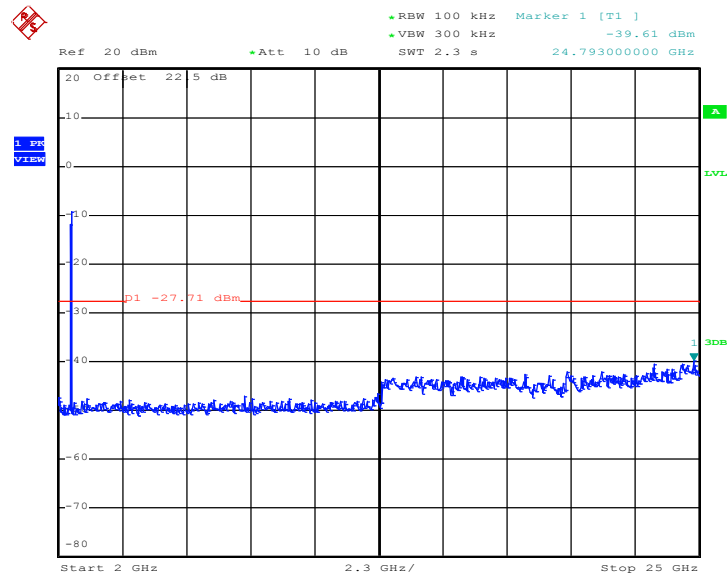

Date: 7.AUG.2012 07:45:45



Test Mode :	802.11n HT-40 SISO Ant. 0	Temperature :	24~26°C
Test Band :	30MHz-3GHz and 2G-25GHz	Relative Humidity :	55~58%
Test Channel :	03, 06, 09	Test Engineer :	Bill Kuo

802.11n HT-40 30 MHz~3 GHz

Conducted Spurious Emission Plot on Channel 03

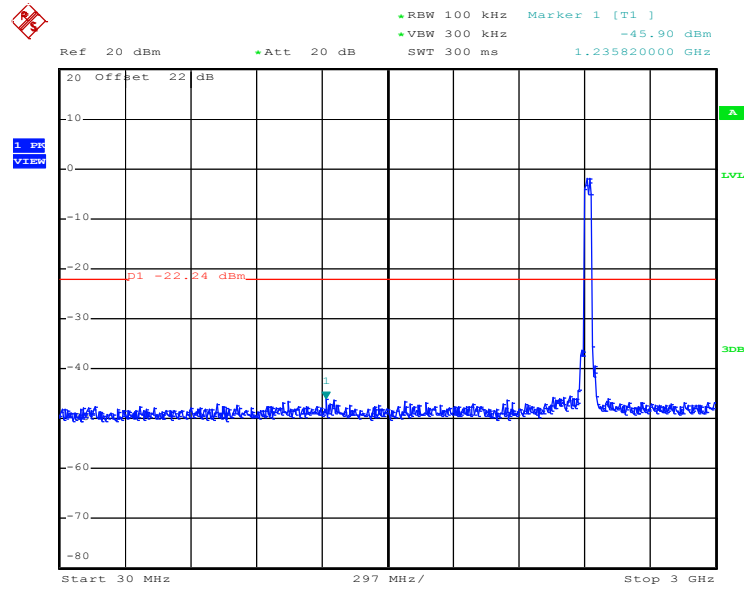

Date: 7.AUG.2012 06:45:34

802.11n HT-40 2 GHz~25 GHz

Conducted Spurious Emission Plot on Channel 03

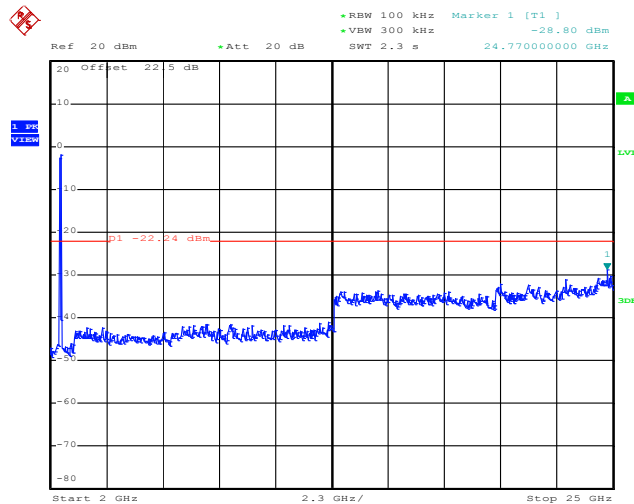

Date: 7.AUG.2012 06:45:53



802.11n HT-40 30 MHz~3 GHz

Conducted Spurious Emission Plot on Channel 06

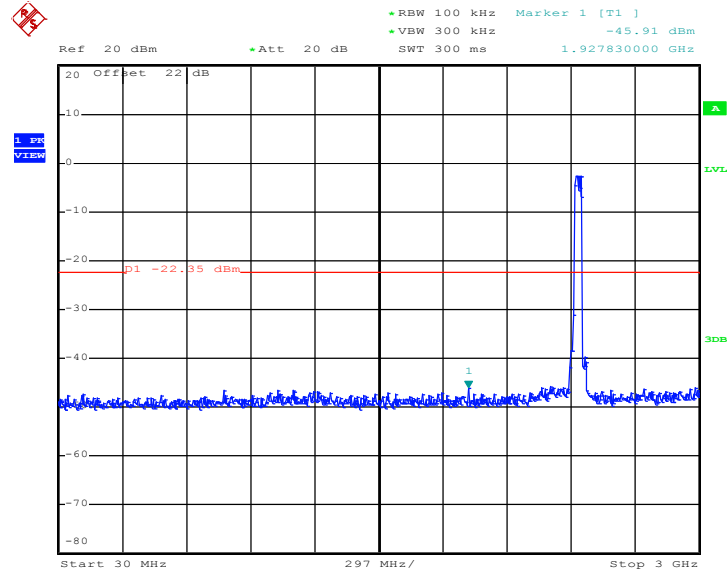

Date: 7.AUG.2012 06:49:27

802.11n HT-40 2 GHz~25 GHz

Conducted Spurious Emission Plot on Channel 06

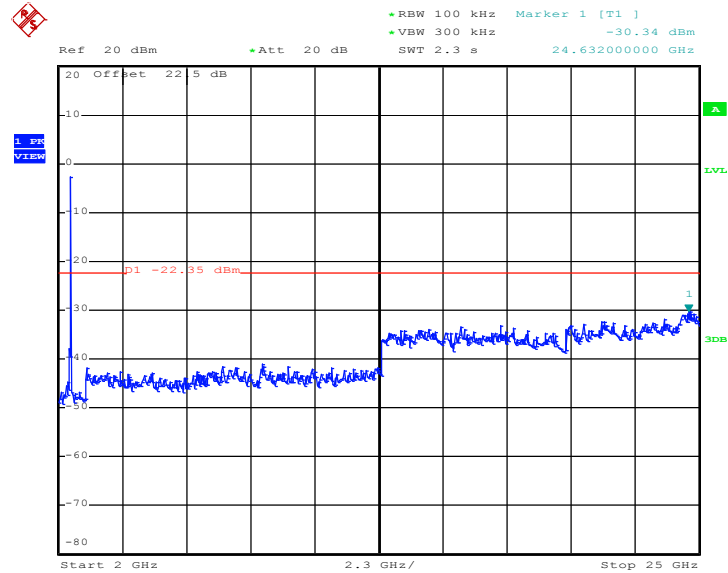

Date: 7.AUG.2012 06:49:46



802.11n HT-40 30 MHz~3 GHz

Conducted Spurious Emission Plot on Channel 09

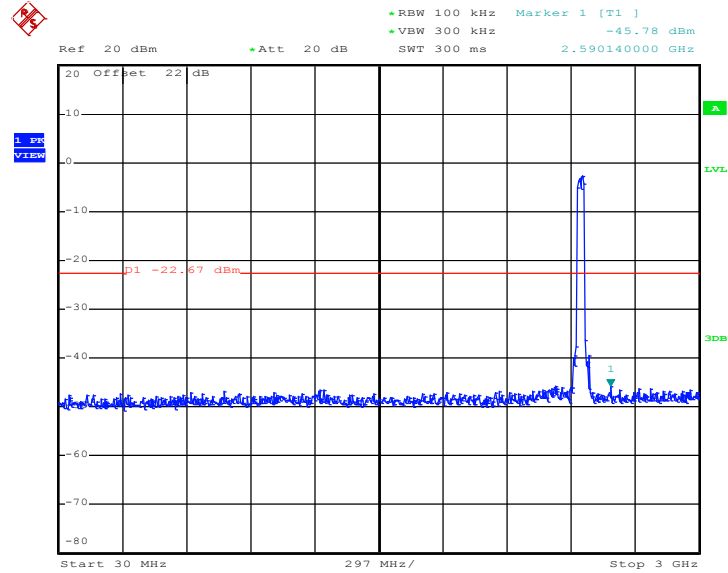

Date: 7.AUG.2012 06:53:34

802.11n HT-40 2 GHz~25 GHz

Conducted Spurious Emission Plot on Channel 09

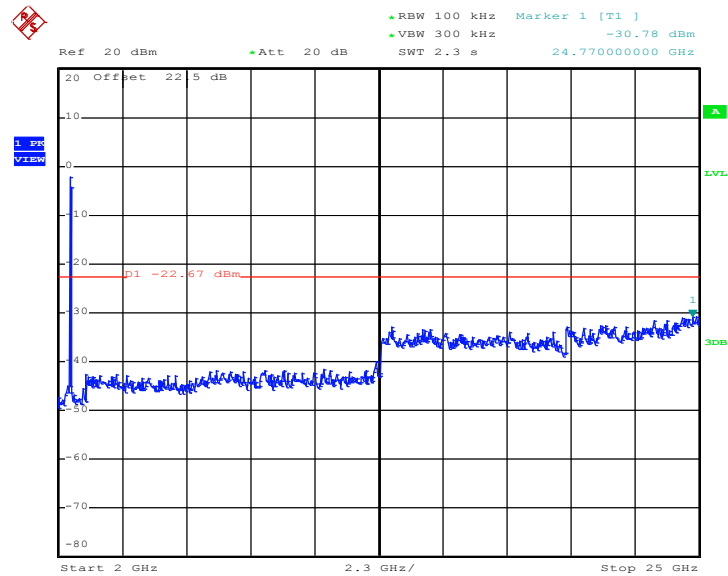

Date: 7.AUG.2012 06:53:52



Test Mode :	802.11n HT-40 MIMO Ant. 0+1(0)	Temperature :	24~26°C
Test Band :	30MHz-3GHz and 2G-25GHz	Relative Humidity :	55~58%
Test Channel :	03, 06, 09	Test Engineer :	Bill Kuo

802.11n HT-40 30 MHz~3 GHz

Conducted Spurious Emission Plot on Channel 03

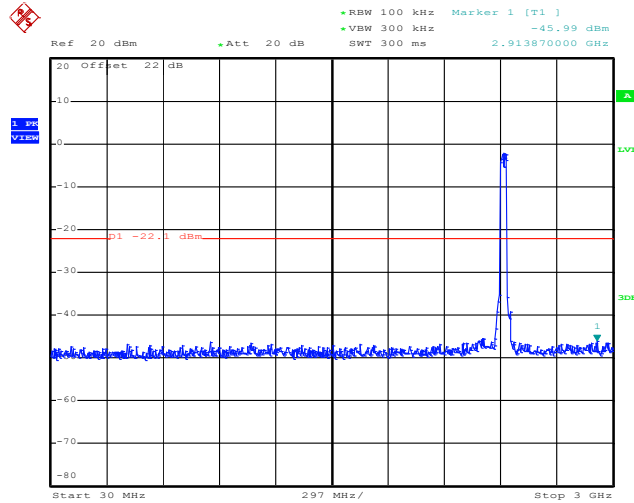

Date: 7.AUG.2012 07:06:22

802.11n HT-40 2 GHz~25 GHz

Conducted Spurious Emission Plot on Channel 03

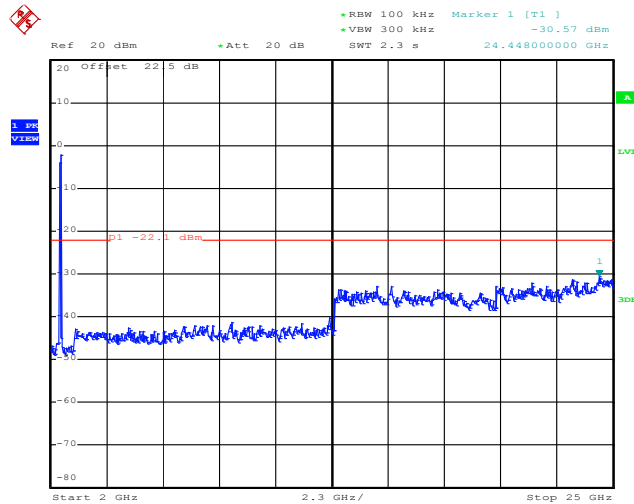

Date: 7.AUG.2012 07:06:41



802.11n HT-40 30 MHz~3 GHz

Conducted Spurious Emission Plot on Channel 06

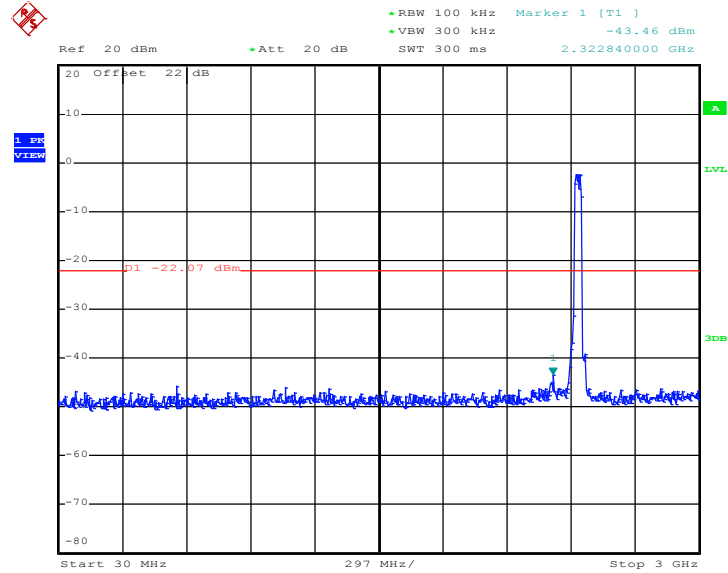

Date: 7.AUG.2012 07:02:39

802.11n HT-40 2 GHz~25 GHz

Conducted Spurious Emission Plot on Channel 06

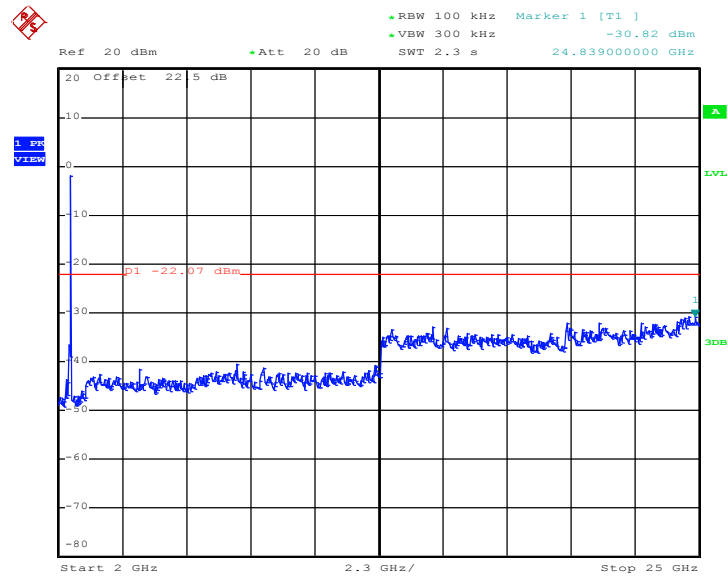

Date: 7.AUG.2012 07:02:58



802.11n HT-40 30 MHz~3 GHz

Conducted Spurious Emission Plot on Channel 09

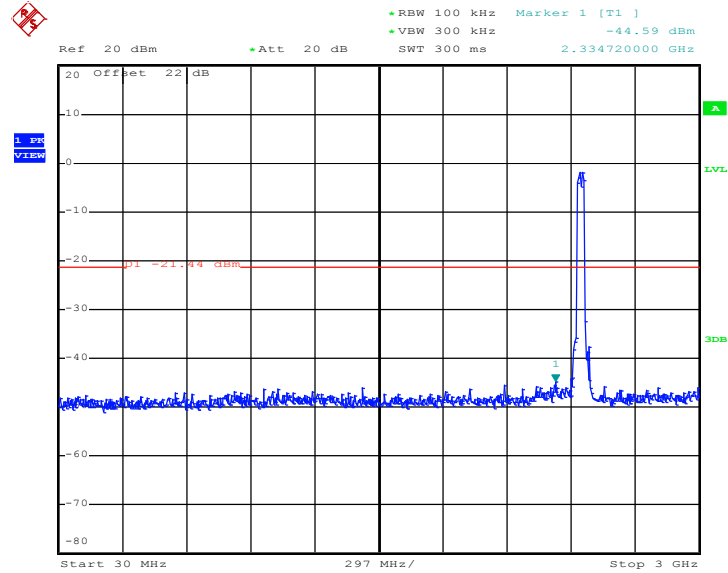

Date: 7.AUG.2012 06:59:20

802.11n HT-40 2 GHz~25 GHz

Conducted Spurious Emission Plot on Channel 09

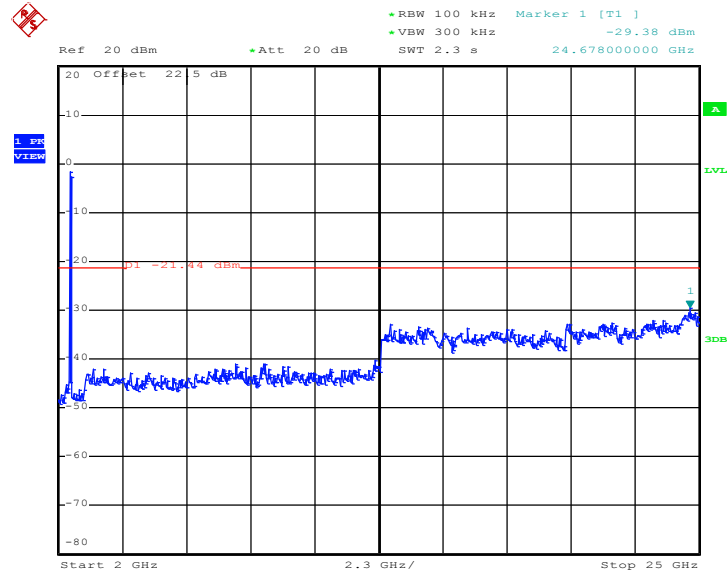

Date: 7.AUG.2012 06:59:39



Test Mode :	802.11n HT-40 MIMO Ant. 0+1(1)	Temperature :	24~26°C
Test Band :	30MHz-3GHz and 2G-25GHz	Relative Humidity :	55~58%
Test Channel :	03, 06, 09	Test Engineer :	Bill Kuo

802.11n HT-40 30 MHz~3 GHz

Conducted Spurious Emission Plot on Channel 03

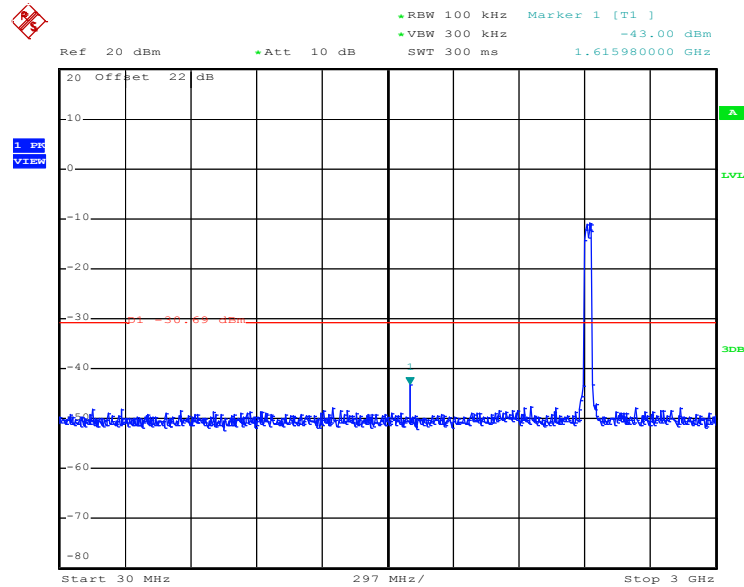

Date: 7.AUG.2012 07:14:15

802.11n HT-40 2 GHz~25 GHz

Conducted Spurious Emission Plot on Channel 03

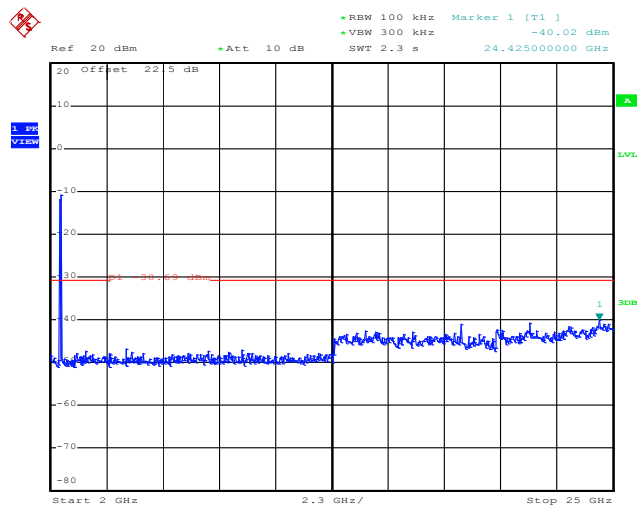

Date: 7.AUG.2012 07:14:33



802.11n HT-40 30 MHz~3 GHz

Conducted Spurious Emission Plot on Channel 06

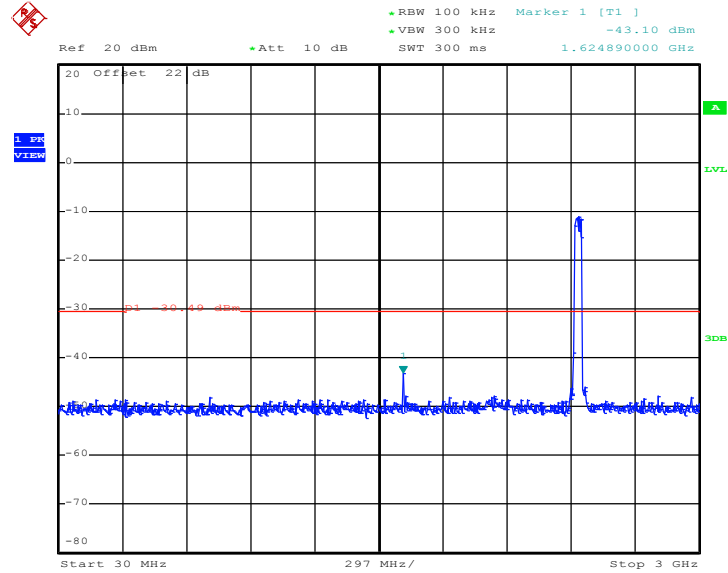

Date: 7.AUG.2012 07:23:11

802.11n HT-40 2 GHz~25 GHz

Conducted Spurious Emission Plot on Channel 06

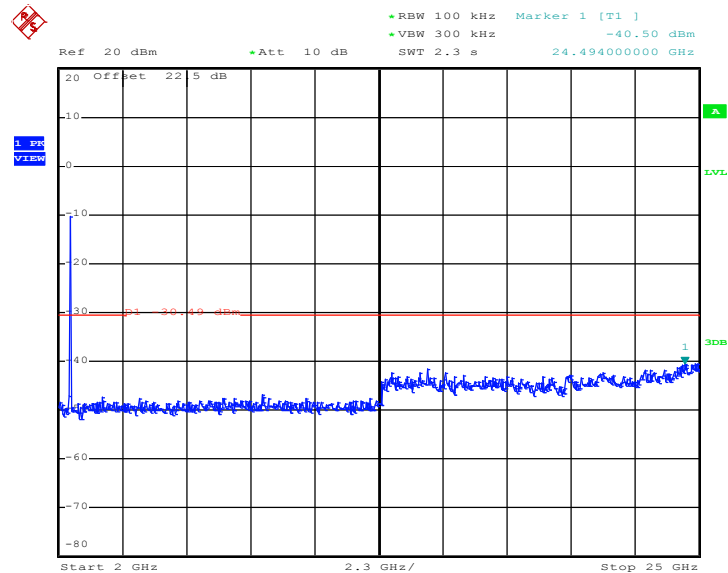

Date: 7.AUG.2012 07:23:30



802.11n HT-40 30 MHz~3 GHz

Conducted Spurious Emission Plot on Channel 09

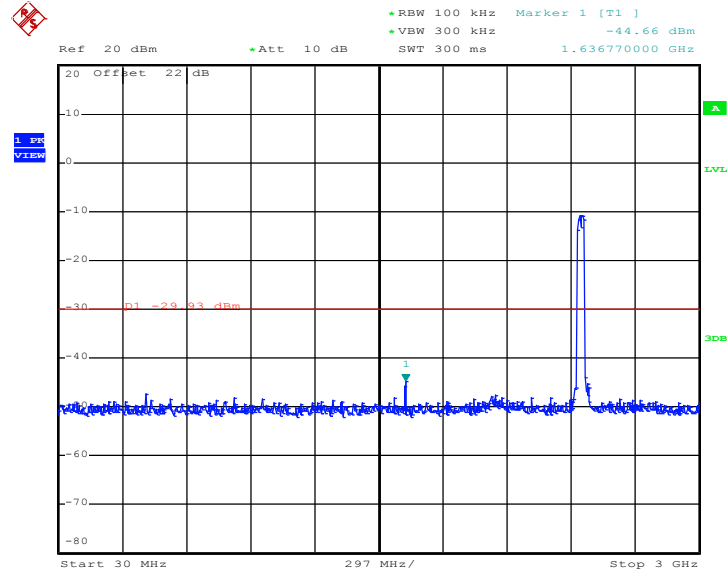

Date: 7.AUG.2012 07:32:41

802.11n HT-40 2 GHz~25 GHz

Conducted Spurious Emission Plot on Channel 09

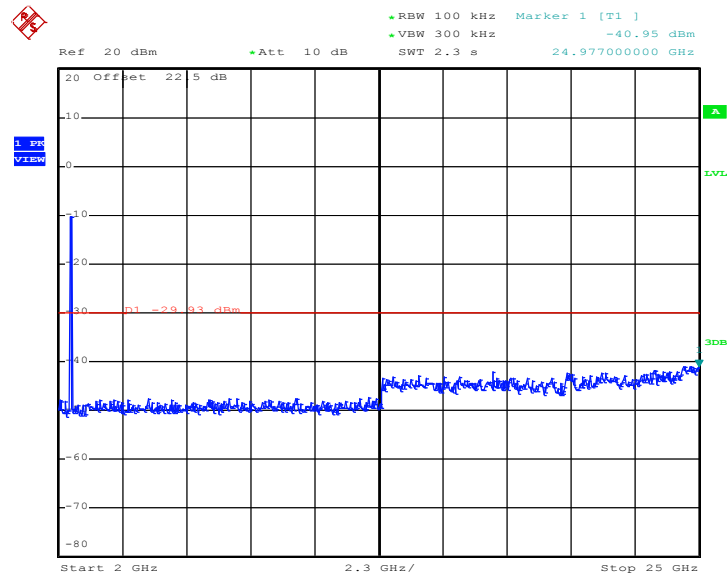

Date: 7.AUG.2012 07:33:00

3.5 Radiated Band Edges and Spurious Emission Measurement

3.5.1 Limit of Radiated band edge and Spurious Emission Measurement

In any 100 KHz bandwidth outside the intentional radiator frequency band, all harmonics/spurious must be at least 20 dB below the highest emission level within the authorized band. If the output power of this device was measured by spectrum analyzer, the attenuation under this paragraph shall be 30 dB instead of 20 dB. In addition, radiated emissions which fall in the restricted bands must also comply with the FCC section 15.209 limits as below.

Frequency (MHz)	Field Strength (microvolts/meter)	Measurement Distance (meters)
0.009 – 0.490	2400/F(KHz)	300
0.490 – 1.705	24000/F(KHz)	30
1.705 – 30.0	30	30
30 – 88	100	3
88 – 216	150	3
216 - 960	200	3
Above 960	500	3

3.5.2 Measuring Instruments

See list of measuring instruments of this test report.



3.5.3 Test Procedure

1. The testing follows TCB Workshop 2012, April and fulfills ANSI C63.4-2003 and the guidelines in ANSI C63.10-2009 test site requirement. For each suspected emission, the EUT was arranged to its worst case and then tune the Antenna tower (from 1 m to 4 m) and turntable (from 0 degree to 360 degrees) to find the maximum reading. A pre-amp and a high pass filter are used for the test in order to get better signal level to comply with the guidelines.
2. The EUT was placed on a turntable with 0.8 meter above ground.
3. The EUT was set 3 meters from the interference receiving Antenna, which was mounted on the top of a variable height Antenna tower.
4. The table was rotated 360 degrees to determine the position of the highest radiation.
5. Use the following spectrum analyzer settings:
6. Use the following spectrum analyzer settings:
 - (1) Span shall wide enough to fully capture the emission being measured;
 - (2) Set RBW=100 KHz for $f < 1$ GHz; $VBW \geq RBW$; Sweep = auto; Detector function = peak; Trace = max hold;
 - (3) Set RBW = 1 MHz, VBW= 3MHz for $f \geq 1$ GHz for Peak measurement, and then set VBW=10Hz, while maintaining all of the other instrument settings for Average measurement.
7. Corrected Reading: Antenna Factor + Cable Loss + Read Level - Preamp Factor = Level
8. If the emission level of the EUT measured by the peak detector is more than 3 dB lower than the applicable limit, the peak emission level will be reported. Otherwise, the emission measurement will be repeated using the quasi-peak detector and reported

3.5.4 Test Setup

For radiated emissions below 30MHz

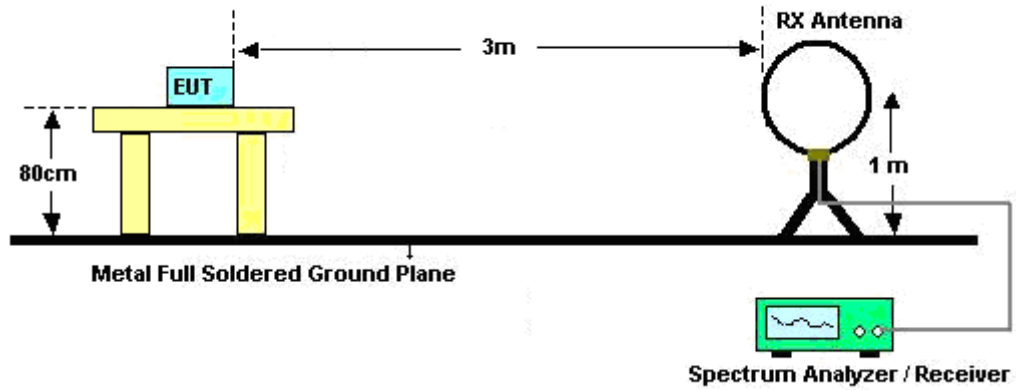

For radiated emissions from 30MHz to 1GHz

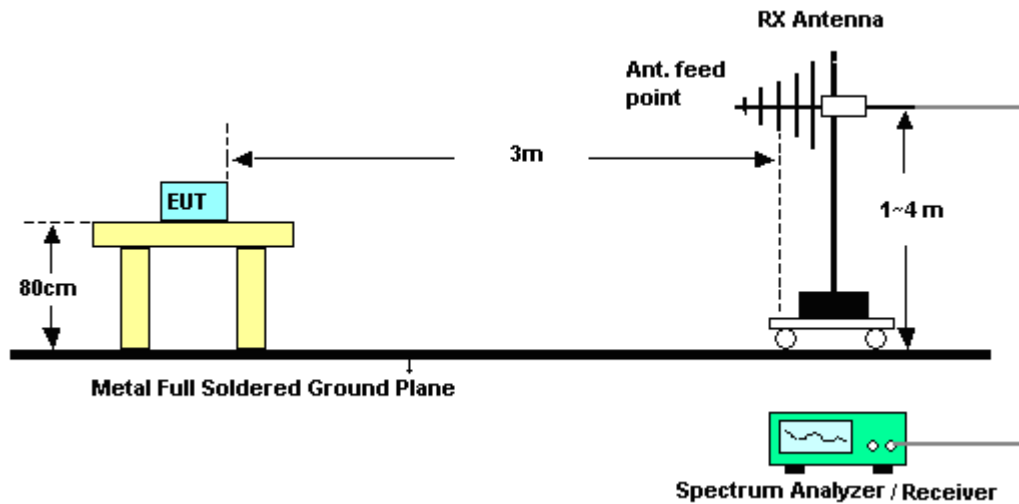

For radiated emissions above 1GHz

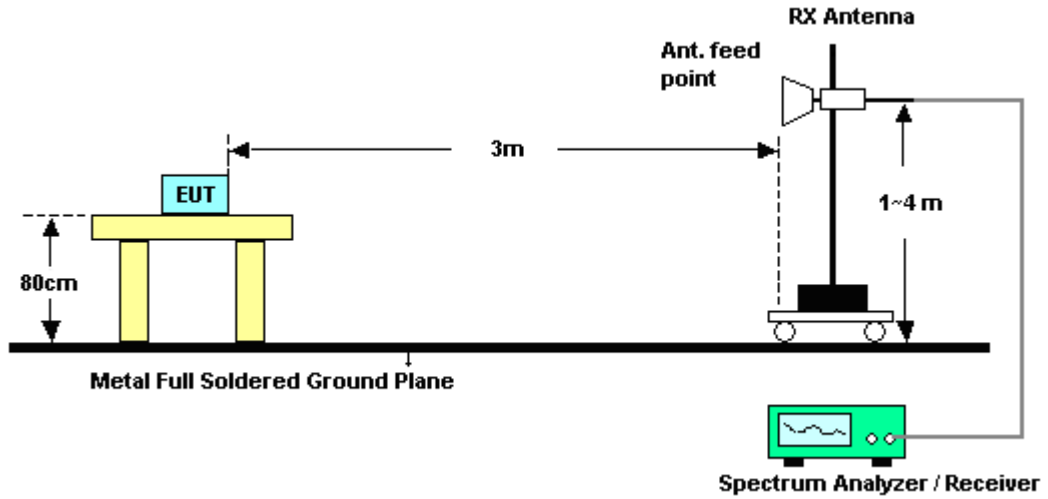

3.5.5 Test Results of Radiated Emissions (9KHz ~ 30MHz)

The low frequency, which started from 9 KHz to 30MHz, was pre-scanned and the result which was 20dB lower than the limit line per 15.31(o) was not reported.



3.5.6 Test Result of Radiated Spurious at Band Edges

Test Mode :	802.11b Ant. 0	Temperature :	23~25°C
Test Band :	Low	Relative Humidity :	51~52%
Test Channel :	01	Test Engineer :	Timberland and Kai Wang

ANTENNA POLARITY : HORIZONTAL										
Frequency (MHz)	Level (dBμV/m)	Over Limit (dB)	Limit Line (dBμV/m)	Read Level (dBμV)	Antenna Factor (dB)	Cable Loss (dB)	Preamp Factor (dB)	Ant Pos (cm)	Table Pos (deg)	Remark
2330.16	53.71	-20.29	74	50.98	31.96	5.31	34.54	100	4	Peak
2329.44	44.44	-9.56	54	41.71	31.96	5.31	34.54	100	4	Average

ANTENNA POLARITY : VERTICAL										
Frequency (MHz)	Level (dBμV/m)	Over Limit (dB)	Limit Line (dBμV/m)	Read Level (dBμV)	Antenna Factor (dB)	Cable Loss (dB)	Preamp Factor (dB)	Ant Pos (cm)	Table Pos (deg)	Remark
2381.37	54.4	-19.6	74	51.54	32	5.4	34.54	100	291	Peak
2382.81	43.9	-10.1	54	41.04	32	5.4	34.54	100	291	Average

Test Mode :	802.11b Ant. 0	Temperature :	23~25°C
Test Band :	High	Relative Humidity :	51~52%
Test Channel :	11	Test Engineer :	Timberland and Kai Wang

ANTENNA POLARITY : HORIZONTAL										
Frequency (MHz)	Level (dBμV/m)	Over Limit (dB)	Limit Line (dBμV/m)	Read Level (dBμV)	Antenna Factor (dB)	Cable Loss (dB)	Preamp Factor (dB)	Ant Pos (cm)	Table Pos (deg)	Remark
2487	49.11	-24.89	74	46.03	32.09	5.52	34.53	100	40	Peak
2484.06	36.49	-17.51	54	33.41	32.09	5.52	34.53	100	40	Average

ANTENNA POLARITY : VERTICAL										
Frequency (MHz)	Level (dBμV/m)	Over Limit (dB)	Limit Line (dBμV/m)	Read Level (dBμV)	Antenna Factor (dB)	Cable Loss (dB)	Preamp Factor (dB)	Ant Pos (cm)	Table Pos (deg)	Remark
2486.24	51.33	-22.67	74	48.25	32.09	5.52	34.53	100	241	Peak
2483.9	38.37	-15.63	54	35.29	32.09	5.52	34.53	100	241	Average



Test Mode :	802.11b Ant. 1	Temperature :	23~25°C
Test Band :	Low	Relative Humidity :	51~52%
Test Channel :	01	Test Engineer :	Timberland and Kai Wang

ANTENNA POLARITY : HORIZONTAL										
Frequency (MHz)	Level (dBμV/m)	Over Limit (dB)	Limit Line (dBμV/m)	Read Level (dBμV)	Antenna Factor (dB)	Cable Loss (dB)	Preamp Factor (dB)	Ant Pos (cm)	Table Pos (deg)	Remark
2386.05	47.14	-26.86	74	46.26	30.04	5.4	34.56	102	177	Peak
2386.5	35.94	-18.06	54	35.06	30.04	5.4	34.56	102	177	Average

ANTENNA POLARITY : VERTICAL										
Frequency (MHz)	Level (dBμV/m)	Over Limit (dB)	Limit Line (dBμV/m)	Read Level (dBμV)	Antenna Factor (dB)	Cable Loss (dB)	Preamp Factor (dB)	Ant Pos (cm)	Table Pos (deg)	Remark
2387.31	50.53	-23.47	74	49.65	30.04	5.4	34.56	105	269	Peak
2386.5	40.93	-13.07	54	40.05	30.04	5.4	34.56	105	269	Average

Test Mode :	802.11b Ant. 1	Temperature :	23~25°C
Test Band :	High	Relative Humidity :	51~52%
Test Channel :	11	Test Engineer :	Timberland and Kai Wang

ANTENNA POLARITY : HORIZONTAL										
Frequency (MHz)	Level (dBμV/m)	Over Limit (dB)	Limit Line (dBμV/m)	Read Level (dBμV)	Antenna Factor (dB)	Cable Loss (dB)	Preamp Factor (dB)	Ant Pos (cm)	Table Pos (deg)	Remark
2488.22	47.85	-26.15	74	46.88	30	5.52	34.55	100	130	Peak
2487.7	37.63	-16.37	54	36.66	30	5.52	34.55	100	130	Average

ANTENNA POLARITY : VERTICAL										
Frequency (MHz)	Level (dBμV/m)	Over Limit (dB)	Limit Line (dBμV/m)	Read Level (dBμV)	Antenna Factor (dB)	Cable Loss (dB)	Preamp Factor (dB)	Ant Pos (cm)	Table Pos (deg)	Remark
2488.26	51.41	-22.59	74	50.44	30	5.52	34.55	102	286	Peak
2487.8	41.71	-12.29	54	40.74	30	5.52	34.55	102	286	Average



Test Mode :	802.11g Ant. 0	Temperature :	23~25°C
Test Band :	Low	Relative Humidity :	51~52%
Test Channel :	01	Test Engineer :	Timberland and Kai Wang

ANTENNA POLARITY : HORIZONTAL										
Frequency (MHz)	Level (dBμV/m)	Over Limit (dB)	Limit Line (dBμV/m)	Read Level (dBμV)	Antenna Factor (dB)	Cable Loss (dB)	Preamp Factor (dB)	Ant Pos (cm)	Table Pos (deg)	Remark
2327.28	53.06	-20.94	74	50.33	31.96	5.31	34.54	100	338	Peak
2325.57	41.35	-12.65	54	38.62	31.96	5.31	34.54	100	338	Average

ANTENNA POLARITY : VERTICAL										
Frequency (MHz)	Level (dBμV/m)	Over Limit (dB)	Limit Line (dBμV/m)	Read Level (dBμV)	Antenna Factor (dB)	Cable Loss (dB)	Preamp Factor (dB)	Ant Pos (cm)	Table Pos (deg)	Remark
2388.21	54.38	-19.62	74	51.5	32.02	5.4	34.54	100	293	Peak
2381.28	41.12	-12.88	54	38.26	32	5.4	34.54	100	293	Average

Test Mode :	802.11g Ant. 0	Temperature :	23~25°C
Test Band :	High	Relative Humidity :	51~52%
Test Channel :	11	Test Engineer :	Timberland and Kai Wang

ANTENNA POLARITY : HORIZONTAL										
Frequency (MHz)	Level (dBμV/m)	Over Limit (dB)	Limit Line (dBμV/m)	Read Level (dBμV)	Antenna Factor (dB)	Cable Loss (dB)	Preamp Factor (dB)	Ant Pos (cm)	Table Pos (deg)	Remark
2485.46	48.94	-25.06	74	45.86	32.09	5.52	34.53	100	38	Peak
2483.78	36.37	-17.63	54	33.29	32.09	5.52	34.53	100	38	Average

ANTENNA POLARITY : VERTICAL										
Frequency (MHz)	Level (dBμV/m)	Over Limit (dB)	Limit Line (dBμV/m)	Read Level (dBμV)	Antenna Factor (dB)	Cable Loss (dB)	Preamp Factor (dB)	Ant Pos (cm)	Table Pos (deg)	Remark
2483.7	51	-23	74	47.92	32.09	5.52	34.53	100	241	Peak
2483.5	37.67	-16.33	54	34.59	32.09	5.52	34.53	100	241	Average



Test Mode :	802.11g Ant. 1	Temperature :	23~25°C
Test Band :	Low	Relative Humidity :	51~52%
Test Channel :	01	Test Engineer :	Timberland and Kai Wang

ANTENNA POLARITY : HORIZONTAL										
Frequency (MHz)	Level (dBμV/m)	Over Limit (dB)	Limit Line (dBμV/m)	Read Level (dBμV)	Antenna Factor (dB)	Cable Loss (dB)	Preamp Factor (dB)	Ant Pos (cm)	Table Pos (deg)	Remark
2389.92	48.3	-25.7	74	47.42	30.04	5.4	34.56	100	180	Peak
2390	33.5	-20.5	54	32.62	30.04	5.4	34.56	100	180	Average

ANTENNA POLARITY : VERTICAL										
Frequency (MHz)	Level (dBμV/m)	Over Limit (dB)	Limit Line (dBμV/m)	Read Level (dBμV)	Antenna Factor (dB)	Cable Loss (dB)	Preamp Factor (dB)	Ant Pos (cm)	Table Pos (deg)	Remark
2388.66	53.81	-20.19	74	52.93	30.04	5.4	34.56	105	282	Peak
2390	37.39	-16.61	54	36.51	30.04	5.4	34.56	105	282	Average

Test Mode :	802.11g Ant. 1	Temperature :	23~25°C
Test Band :	High	Relative Humidity :	51~52%
Test Channel :	11	Test Engineer :	Timberland and Kai Wang

ANTENNA POLARITY : HORIZONTAL										
Frequency (MHz)	Level (dBμV/m)	Over Limit (dB)	Limit Line (dBμV/m)	Read Level (dBμV)	Antenna Factor (dB)	Cable Loss (dB)	Preamp Factor (dB)	Ant Pos (cm)	Table Pos (deg)	Remark
2484.78	47.56	-26.44	74	46.58	30.01	5.52	34.55	100	130	Peak
2483.5	34.04	-19.96	54	33.06	30.01	5.52	34.55	100	130	Average

ANTENNA POLARITY : VERTICAL										
Frequency (MHz)	Level (dBμV/m)	Over Limit (dB)	Limit Line (dBμV/m)	Read Level (dBμV)	Antenna Factor (dB)	Cable Loss (dB)	Preamp Factor (dB)	Ant Pos (cm)	Table Pos (deg)	Remark
2483.94	50.75	-23.25	74	49.77	30.01	5.52	34.55	104	286	Peak
2483.5	36.68	-17.32	54	35.7	30.01	5.52	34.55	104	286	Average



Test Mode :	802.11n HT-20 Ant. 0	Temperature :	23~25°C
Test Band :	Low	Relative Humidity :	51~52%
Test Channel :	01	Test Engineer :	Timberland and Kai Wang

ANTENNA POLARITY : HORIZONTAL										
Frequency (MHz)	Level (dBμV/m)	Over Limit (dB)	Limit Line (dBμV/m)	Read Level (dBμV)	Antenna Factor (dB)	Cable Loss (dB)	Preamp Factor (dB)	Ant Pos (cm)	Table Pos (deg)	Remark
2330.34	53.29	-20.71	74	52.48	30.07	5.31	34.57	100	6	Peak
2329.62	39.5	-14.5	54	38.69	30.07	5.31	34.57	100	6	Average

ANTENNA POLARITY : VERTICAL										
Frequency (MHz)	Level (dBμV/m)	Over Limit (dB)	Limit Line (dBμV/m)	Read Level (dBμV)	Antenna Factor (dB)	Cable Loss (dB)	Preamp Factor (dB)	Ant Pos (cm)	Table Pos (deg)	Remark
2384.25	52.5	-21.5	74	51.61	30.05	5.4	34.56	105	298	Peak
2381.46	38.95	-15.05	54	38.06	30.05	5.4	34.56	105	298	Average

Test Mode :	802.11n HT-20 Ant. 0	Temperature :	23~25°C
Test Band :	High	Relative Humidity :	51~52%
Test Channel :	11	Test Engineer :	Timberland and Kai Wang

ANTENNA POLARITY : HORIZONTAL										
Frequency (MHz)	Level (dBμV/m)	Over Limit (dB)	Limit Line (dBμV/m)	Read Level (dBμV)	Antenna Factor (dB)	Cable Loss (dB)	Preamp Factor (dB)	Ant Pos (cm)	Table Pos (deg)	Remark
2483.88	48.77	-25.23	74	45.69	32.09	5.52	34.53	100	38	Peak
2483.5	35.83	-18.17	54	32.75	32.09	5.52	34.53	100	38	Average

ANTENNA POLARITY : VERTICAL										
Frequency (MHz)	Level (dBμV/m)	Over Limit (dB)	Limit Line (dBμV/m)	Read Level (dBμV)	Antenna Factor (dB)	Cable Loss (dB)	Preamp Factor (dB)	Ant Pos (cm)	Table Pos (deg)	Remark
2487.34	50.13	-23.87	74	47.05	32.09	5.52	34.53	100	246	Peak
2483.5	36.75	-17.25	54	33.67	32.09	5.52	34.53	100	246	Average



Test Mode :	802.11n HT-20 Ant. 1	Temperature :	23~25°C
Test Band :	Low	Relative Humidity :	51~52%
Test Channel :	01	Test Engineer :	Timberland and Kai Wang

ANTENNA POLARITY : HORIZONTAL										
Frequency (MHz)	Level (dBμV/m)	Over Limit (dB)	Limit Line (dBμV/m)	Read Level (dBμV)	Antenna Factor (dB)	Cable Loss (dB)	Preamp Factor (dB)	Ant Pos (cm)	Table Pos (deg)	Remark
2389.11	46.89	-27.11	74	46.01	30.04	5.4	34.56	100	176	Peak
2390	33.3	-20.7	54	32.42	30.04	5.4	34.56	100	176	Average

ANTENNA POLARITY : VERTICAL										
Frequency (MHz)	Level (dBμV/m)	Over Limit (dB)	Limit Line (dBμV/m)	Read Level (dBμV)	Antenna Factor (dB)	Cable Loss (dB)	Preamp Factor (dB)	Ant Pos (cm)	Table Pos (deg)	Remark
2389.83	53.08	-20.92	74	52.2	30.04	5.4	34.56	107	284	Peak
2390	37.53	-16.47	54	36.65	30.04	5.4	34.56	107	284	Average

Test Mode :	802.11n HT-20 Ant. 1	Temperature :	23~25°C
Test Band :	High	Relative Humidity :	51~52%
Test Channel :	11	Test Engineer :	Timberland and Kai Wang

ANTENNA POLARITY : HORIZONTAL										
Frequency (MHz)	Level (dBμV/m)	Over Limit (dB)	Limit Line (dBμV/m)	Read Level (dBμV)	Antenna Factor (dB)	Cable Loss (dB)	Preamp Factor (dB)	Ant Pos (cm)	Table Pos (deg)	Remark
2484.14	49.14	-24.86	74	48.16	30.01	5.52	34.55	100	131	Peak
2483.5	33.88	-20.12	54	32.9	30.01	5.52	34.55	100	131	Average

ANTENNA POLARITY : VERTICAL										
Frequency (MHz)	Level (dBμV/m)	Over Limit (dB)	Limit Line (dBμV/m)	Read Level (dBμV)	Antenna Factor (dB)	Cable Loss (dB)	Preamp Factor (dB)	Ant Pos (cm)	Table Pos (deg)	Remark
2483.66	53.16	-20.84	74	52.18	30.01	5.52	34.55	103	287	Peak
2483.5	36.91	-17.09	54	35.93	30.01	5.52	34.55	103	287	Average



Test Mode :	802.11n HT-20 MIMO Ant. 0+1	Temperature :	23~25°C
Test Band :	Low	Relative Humidity :	51~52%
Test Channel :	01	Test Engineer :	Timberland and Kai Wang

ANTENNA POLARITY : HORIZONTAL										
Frequency (MHz)	Level (dBμV/m)	Over Limit (dB)	Limit Line (dBμV/m)	Read Level (dBμV)	Antenna Factor (dB)	Cable Loss (dB)	Preamp Factor (dB)	Ant Pos (cm)	Table Pos (deg)	Remark
2330.52	50.18	-23.82	74	49.37	30.07	5.31	34.57	100	8	Peak
2329.53	37.44	-16.56	54	36.63	30.07	5.31	34.57	100	8	Average

ANTENNA POLARITY : VERTICAL										
Frequency (MHz)	Level (dBμV/m)	Over Limit (dB)	Limit Line (dBμV/m)	Read Level (dBμV)	Antenna Factor (dB)	Cable Loss (dB)	Preamp Factor (dB)	Ant Pos (cm)	Table Pos (deg)	Remark
2389.56	52.91	-21.09	74	52.03	30.04	5.4	34.56	106	270	Peak
2390	39	-15	54	38.12	30.04	5.4	34.56	106	270	Average

Test Mode :	802.11n HT-20 MIMO Ant. 0+1	Temperature :	23~25°C
Test Band :	High	Relative Humidity :	51~52%
Test Channel :	11	Test Engineer :	Timberland and Kai Wang

ANTENNA POLARITY : HORIZONTAL										
Frequency (MHz)	Level (dBμV/m)	Over Limit (dB)	Limit Line (dBμV/m)	Read Level (dBμV)	Antenna Factor (dB)	Cable Loss (dB)	Preamp Factor (dB)	Ant Pos (cm)	Table Pos (deg)	Remark
2483.68	47.8	-26.2	74	46.82	30.01	5.52	34.55	100	37	Peak
2483.62	33.66	-20.34	54	32.68	30.01	5.52	34.55	100	37	Average

ANTENNA POLARITY : VERTICAL										
Frequency (MHz)	Level (dBμV/m)	Over Limit (dB)	Limit Line (dBμV/m)	Read Level (dBμV)	Antenna Factor (dB)	Cable Loss (dB)	Preamp Factor (dB)	Ant Pos (cm)	Table Pos (deg)	Remark
2483.8	48.3	-25.7	74	47.32	30.01	5.52	34.55	104	236	Peak
2483.5	34.69	-19.31	54	33.71	30.01	5.52	34.55	104	236	Average



Test Mode :	802.11n HT-40 Ant. 0	Temperature :	23~25°C
Test Band :	Low	Relative Humidity :	51~52%
Test Channel :	03	Test Engineer :	Timberland and Kai Wang

ANTENNA POLARITY : HORIZONTAL										
Frequency (MHz)	Level (dBμV/m)	Over Limit (dB)	Limit Line (dBμV/m)	Read Level (dBμV)	Antenna Factor (dB)	Cable Loss (dB)	Preamp Factor (dB)	Ant Pos (cm)	Table Pos (deg)	Remark
2387.85	61.52	-12.48	74	60.64	30.04	5.4	34.56	100	7	Peak
2390	43.74	-10.26	54	42.86	30.04	5.4	34.56	100	7	Average

ANTENNA POLARITY : VERTICAL										
Frequency (MHz)	Level (dBμV/m)	Over Limit (dB)	Limit Line (dBμV/m)	Read Level (dBμV)	Antenna Factor (dB)	Cable Loss (dB)	Preamp Factor (dB)	Ant Pos (cm)	Table Pos (deg)	Remark
2388.03	63.02	-10.98	74	62.14	30.04	5.4	34.56	104	286	Peak
2390	44.45	-9.55	54	43.57	30.04	5.4	34.56	104	286	Average

Test Mode :	802.11n HT-40 Ant. 0	Temperature :	23~25°C
Test Band :	High	Relative Humidity :	51~52%
Test Channel :	09	Test Engineer :	Timberland and Kai Wang

ANTENNA POLARITY : HORIZONTAL										
Frequency (MHz)	Level (dBμV/m)	Over Limit (dB)	Limit Line (dBμV/m)	Read Level (dBμV)	Antenna Factor (dB)	Cable Loss (dB)	Preamp Factor (dB)	Ant Pos (cm)	Table Pos (deg)	Remark
2483.6	57.72	-16.28	74	56.74	30.01	5.52	34.55	100	27	Peak
2483.54	38.98	-15.02	54	38	30.01	5.52	34.55	100	27	Average

ANTENNA POLARITY : VERTICAL										
Frequency (MHz)	Level (dBμV/m)	Over Limit (dB)	Limit Line (dBμV/m)	Read Level (dBμV)	Antenna Factor (dB)	Cable Loss (dB)	Preamp Factor (dB)	Ant Pos (cm)	Table Pos (deg)	Remark
2483.66	56.29	-17.71	74	55.31	30.01	5.52	34.55	104	263	Peak
2483.5	38.49	-15.51	54	37.51	30.01	5.52	34.55	104	263	Average



Test Mode :	802.11n HT-40 Ant. 1	Temperature :	23~25°C
Test Band :	Low	Relative Humidity :	51~52%
Test Channel :	03	Test Engineer :	Timberland and Kai Wang

ANTENNA POLARITY : HORIZONTAL										
Frequency (MHz)	Level (dBμV/m)	Over Limit (dB)	Limit Line (dBμV/m)	Read Level (dBμV)	Antenna Factor (dB)	Cable Loss (dB)	Preamp Factor (dB)	Ant Pos (cm)	Table Pos (deg)	Remark
2388.48	61.93	-12.07	74	61.05	30.04	5.4	34.56	100	129	Peak
2389.92	42.05	-11.95	54	41.17	30.04	5.4	34.56	100	129	Average

ANTENNA POLARITY : VERTICAL										
Frequency (MHz)	Level (dBμV/m)	Over Limit (dB)	Limit Line (dBμV/m)	Read Level (dBμV)	Antenna Factor (dB)	Cable Loss (dB)	Preamp Factor (dB)	Ant Pos (cm)	Table Pos (deg)	Remark
2383.98	67.57	-6.43	74	66.68	30.05	5.4	34.56	106	282	Peak
2389.83	45.98	-8.02	54	45.1	30.04	5.4	34.56	106	282	Average

Test Mode :	802.11n HT-40 Ant. 1	Temperature :	23~25°C
Test Band :	High	Relative Humidity :	51~52%
Test Channel :	09	Test Engineer :	Timberland and Kai Wang

ANTENNA POLARITY : HORIZONTAL										
Frequency (MHz)	Level (dBμV/m)	Over Limit (dB)	Limit Line (dBμV/m)	Read Level (dBμV)	Antenna Factor (dB)	Cable Loss (dB)	Preamp Factor (dB)	Ant Pos (cm)	Table Pos (deg)	Remark
2494.4	62.18	-11.82	74	61.21	30	5.52	34.55	100	128	Peak
2484.04	41.14	-12.86	54	40.16	30.01	5.52	34.55	100	128	Average

ANTENNA POLARITY : VERTICAL										
Frequency (MHz)	Level (dBμV/m)	Over Limit (dB)	Limit Line (dBμV/m)	Read Level (dBμV)	Antenna Factor (dB)	Cable Loss (dB)	Preamp Factor (dB)	Ant Pos (cm)	Table Pos (deg)	Remark
2494.84	68.73	-5.27	74	67.76	30	5.52	34.55	103	287	Peak
2484.02	45.45	-8.55	54	44.47	30.01	5.52	34.55	103	287	Average



Test Mode :	802.11n HT-40 MIMO Ant. 0+1	Temperature :	23~25°C
Test Band :	Low	Relative Humidity :	51~52%
Test Channel :	03	Test Engineer :	Timberland and Kai Wang

ANTENNA POLARITY : HORIZONTAL										
Frequency (MHz)	Level (dBμV/m)	Over Limit (dB)	Limit Line (dBμV/m)	Read Level (dBμV)	Antenna Factor (dB)	Cable Loss (dB)	Preamp Factor (dB)	Ant Pos (cm)	Table Pos (deg)	Remark
2387.94	64.02	-9.98	74	63.14	30.04	5.4	34.56	100	6	Peak
2390	43.65	-10.35	54	42.77	30.04	5.4	34.56	100	6	Average

ANTENNA POLARITY : VERTICAL										
Frequency (MHz)	Level (dBμV/m)	Over Limit (dB)	Limit Line (dBμV/m)	Read Level (dBμV)	Antenna Factor (dB)	Cable Loss (dB)	Preamp Factor (dB)	Ant Pos (cm)	Table Pos (deg)	Remark
2383.62	66.11	-7.89	74	65.22	30.05	5.4	34.56	107	298	Peak
2390	45.02	-8.98	54	44.14	30.04	5.4	34.56	107	298	Average

Test Mode :	802.11n HT-40 MIMO Ant. 0+1	Temperature :	23~25°C
Test Band :	High	Relative Humidity :	51~52%
Test Channel :	09	Test Engineer :	Timberland and Kai Wang

ANTENNA POLARITY : HORIZONTAL										
Frequency (MHz)	Level (dBμV/m)	Over Limit (dB)	Limit Line (dBμV/m)	Read Level (dBμV)	Antenna Factor (dB)	Cable Loss (dB)	Preamp Factor (dB)	Ant Pos (cm)	Table Pos (deg)	Remark
2483.64	58.54	-15.46	74	57.56	30.01	5.52	34.55	100	36	Peak
2483.76	39.78	-14.22	54	38.8	30.01	5.52	34.55	100	36	Average

ANTENNA POLARITY : VERTICAL										
Frequency (MHz)	Level (dBμV/m)	Over Limit (dB)	Limit Line (dBμV/m)	Read Level (dBμV)	Antenna Factor (dB)	Cable Loss (dB)	Preamp Factor (dB)	Ant Pos (cm)	Table Pos (deg)	Remark
2494.72	61.19	-12.81	74	60.22	30	5.52	34.55	105	265	Peak
2483.54	40.8	-13.2	54	39.82	30.01	5.52	34.55	105	265	Average

3.5.7 Test Result of Radiated Spurious Emission (30MHz ~ 10th Harmonic)

Test Mode :	802.11b Ant. 0	Temperature :	23~25°C
Test Channel :	01	Relative Humidity :	51~52%
Test Engineer :	Timberland and Kai Wang	Polarization :	Horizontal
Remark :	1. 2412 MHz is fundamental signal which can be ignored. 2. 3216 MHz is not within a restricted band, and its limit line is 20dB below the highest emission level. For example, 97.9 dBuV/m - 20dB = 77.9 dBuV/m.		

Frequency (MHz)	Level (dBμV/m)	Over Limit (dB)	Limit Line (dBμV/m)	Read Level (dBμV)	Antenna Factor (dB)	Cable Loss (dB)	Preamp Factor (dB)	Ant Pos (cm)	Table Pos (deg)	Remark
2412	93.29	-	-	90.51	31.91	5.43	34.56	100	4	Average
2412	97.9	-	-	95.12	31.91	5.43	34.56	100	4	Peak
3216	52	-25.9	77.9	69.23	30.46	6.35	54.04	100	0	Peak

Test Mode :	802.11b Ant. 0	Temperature :	23~25°C
Test Channel :	01	Relative Humidity :	51~52%
Test Engineer :	Timberland and Kai Wang	Polarization :	Vertical
Remark :	1. 2412 MHz is Fundamental signal which can be ignored. 2. 3216 MHz is not within a restricted band, and its limit line is 20dB below the highest emission level.		

Frequency (MHz)	Level (dBμV/m)	Over Limit (dB)	Limit Line (dBμV/m)	Read Level (dBμV)	Antenna Factor (dB)	Cable Loss (dB)	Preamp Factor (dB)	Ant Pos (cm)	Table Pos (deg)	Remark
2412	97.97	-	-	95.04	32.03	5.43	34.53	100	291	Average
2412	102.65	-	-	99.72	32.03	5.43	34.53	100	291	Peak
3216	52.76	-29.89	82.65	67.35	33.1	6.35	54.04	100	0	Peak



Test Mode :	802.11b Ant. 0	Temperature :	23~25°C
Test Channel :	06	Relative Humidity :	51~52%
Test Engineer :	Timberland and Kai Wang	Polarization :	Horizontal
Remark :	1. 2437 MHz is Fundamental signal which can be ignored. 2. 3249 MHz is not within a restricted, and its limit line is 20dB below the highest emission level.		

Frequency (MHz)	Level (dBμV/m)	Over Limit (dB)	Limit Line (dBμV/m)	Read Level (dBμV)	Antenna Factor (dB)	Cable Loss (dB)	Preamp Factor (dB)	Ant Pos (cm)	Table Pos (deg)	Remark
133.41	29.88	-13.62	43.5	48.62	11.56	1.4	31.7	-	-	Peak
233.31	35.5	-10.5	46	54.29	10.64	2.19	31.62	-	-	Peak
250.05	32.82	-13.18	46	49.79	12.4	2.28	31.65	-	-	Peak
666.8	33.11	-12.89	46	42.49	19.14	3.46	31.98	-	-	Peak
800.5	41.49	-4.51	46	50.02	20	3.44	31.97	100	248	Peak
869.1	36.37	-9.63	46	43.82	20.49	3.85	31.79	-	-	Peak
2437	95.49	-	-	92.64	31.95	5.46	34.56	118	57	Average
2437	100.65	-	-	97.8	31.95	5.46	34.56	118	57	Peak
3249	53.94	-26.71	80.65	71.14	30.45	6.4	54.05	100	0	Peak
4874	49.12	-24.88	74	62.86	33.94	8	55.68	100	0	Peak



Test Mode :	802.11b Ant. 0	Temperature :	23~25°C
Test Channel :	06	Relative Humidity :	51~52%
Test Engineer :	Timberland and Kai Wang	Polarization :	Vertical
Remark :	1. 2437 MHz is Fundamental signal which can be ignored. 2. 3249 MHz is not within a restricted, and its limit line is 20dB below the highest emission level.		

Frequency (MHz)	Level (dBμV/m)	Over Limit (dB)	Limit Line (dBμV/m)	Read Level (dBμV)	Antenna Factor (dB)	Cable Loss (dB)	Preamp Factor (dB)	Ant Pos (cm)	Table Pos (deg)	Remark
47.28	28.71	-11.29	40	50.69	9.1	0.62	31.7	100	249	Peak
133.41	30.49	-13.01	43.5	49.23	11.56	1.4	31.7	-	-	Peak
230.88	30.18	-15.82	46	49.3	10.31	2.17	31.6	-	-	Peak
459.6	31.05	-14.95	46	43.25	17.1	2.55	31.85	-	-	Peak
800.5	31.63	-14.37	46	40.16	20	3.44	31.97	-	-	Peak
867	33.59	-12.41	46	41.07	20.47	3.85	31.8	-	-	Peak
2437	97.3	-	-	94.45	31.95	5.46	34.56	100	278	Average
2437	102.34	-	-	99.51	31.93	5.46	34.56	100	278	Peak
3249	53.65	-28.69	82.34	68.2	33.1	6.4	54.05	100	0	Peak
4874	49.86	-24.14	74	62.69	34.85	8	55.68	100	0	Peak



Test Mode :	802.11b Ant. 0	Temperature :	23~25°C
Test Channel :	11	Relative Humidity :	51~52%
Test Engineer :	Timberland and Kai Wang	Polarization :	Horizontal
Remark :	1. 2462 MHz is fundamental signal which can be ignored. 2. 3282 MHz is not within a restricted band, and its limit line is 20dB below the highest emission level.		

Frequency (MHz)	Level (dBμV/m)	Over Limit (dB)	Limit Line (dBμV/m)	Read Level (dBμV)	Antenna Factor (dB)	Cable Loss (dB)	Preamp Factor (dB)	Ant Pos (cm)	Table Pos (deg)	Remark
2462	91.09	-	-	88.19	31.97	5.49	34.56	100	40	Average
2462	95.99	-	-	93.09	31.97	5.49	34.56	100	40	Peak
3282	54.73	-21.26	75.99	71.92	30.44	6.43	54.06	100	0	Peak
4924	48.97	-5.03	54	62.57	34.14	8.04	55.78	102	310	Average
4924	52.37	-21.63	74	65.97	34.14	8.04	55.78	102	310	Peak

Test Mode :	802.11b Ant. 0	Temperature :	23~25°C
Test Channel :	11	Relative Humidity :	51~52%
Test Engineer :	Timberland and Kai Wang	Polarization :	Vertical
Remark :	1. 2462 MHz is fundamental signal which can be ignored. 2. 3282 MHz is not within a restricted band, and its limit line is 20dB below the highest emission level.		

Frequency (MHz)	Level (dBμV/m)	Over Limit (dB)	Limit Line (dBμV/m)	Read Level (dBμV)	Antenna Factor (dB)	Cable Loss (dB)	Preamp Factor (dB)	Ant Pos (cm)	Table Pos (deg)	Remark
2462	95.21	-	-	92.31	31.97	5.49	34.56	100	241	Average
2462	100.16	-	-	97.26	31.97	5.49	34.56	100	241	Peak
3282	50.96	-29.2	80.16	65.49	33.1	6.43	54.06	100	0	Peak
4924	49.54	-4.46	54	62.45	34.83	8.04	55.78	100	334	Average
4924	52.69	-21.31	74	65.6	34.83	8.04	55.78	100	334	Peak



Test Mode :	802.11b Ant. 1	Temperature :	23~25°C
Test Channel :	01	Relative Humidity :	51~52%
Test Engineer :	Timberland, Kai Wang and Ivan Chiang	Polarization :	Horizontal
Remark :	1. 2412 MHz is fundamental signal which can be ignored. 2. 3216 MHz is not within a restricted band, and its limit line is 20dB below the highest emission level.		

Frequency (MHz)	Level (dBμV/m)	Over Limit (dB)	Limit Line (dBμV/m)	Read Level (dBμV)	Antenna Factor (dB)	Cable Loss (dB)	Preamp Factor (dB)	Ant Pos (cm)	Table Pos (deg)	Remark
2412	89.64	-	-	88.74	30.03	5.43	34.56	102	177	Average
2412	94.21	-	-	93.31	30.03	5.43	34.56	102	177	Peak
3216	55.35	-18.86	74.21	68.51	33.1	7.78	54.04	100	0	Peak
4824	52.95	-1.05	54	63.5	34.87	10.17	55.59	108	18	Average
4824	57.12	-16.88	74	67.67	34.87	10.17	55.59	108	18	Peak

Test Mode :	802.11b Ant. 1	Temperature :	23~25°C
Test Channel :	01	Relative Humidity :	51~52%
Test Engineer :	Timberland and Kai Wang	Polarization :	Vertical
Remark :	1. 2412 MHz is fundamental signal which can be ignored. 2. 3216 MHz is not within a restricted band, and its limit line is 20dB below the highest emission level.		

Frequency (MHz)	Level (dBμV/m)	Over Limit (dB)	Limit Line (dBμV/m)	Read Level (dBμV)	Antenna Factor (dB)	Cable Loss (dB)	Preamp Factor (dB)	Ant Pos (cm)	Table Pos (deg)	Remark
2412	93.32	-	-	92.42	30.03	5.43	34.56	105	269	Average
2412	98.32	-	-	97.42	30.03	5.43	34.56	105	269	Peak
3216	56.11	-22.21	78.32	69.27	33.1	7.78	54.04	100	0	Peak
4824	51	-3	54	61.55	34.87	10.17	55.59	100	32	Average
4824	54.32	-19.68	74	64.87	34.87	10.17	55.59	100	32	Peak



Test Mode :	802.11b Ant. 1	Temperature :	23~25°C
Test Channel :	06	Relative Humidity :	51~52%
Test Engineer :	Timberland and Kai Wang	Polarization :	Horizontal
Remark :	1. 2437 MHz is Fundamental signal which can be ignored. 2. 3249 MHz is not within a restricted band, and its limit line is 20dB below the highest emission level.		

Frequency (MHz)	Level (dBμV/m)	Over Limit (dB)	Limit Line (dBμV/m)	Read Level (dBμV)	Antenna Factor (dB)	Cable Loss (dB)	Preamp Factor (dB)	Ant Pos (cm)	Table Pos (deg)	Remark
2437	89.24	-	-	88.32	30.02	5.46	34.56	100	176	Average
2437	93.65	-	-	92.72	30.03	5.46	34.56	100	176	Peak
3249	55.56	-18.09	73.65	68.69	33.1	7.82	54.05	100	0	Peak
4874	52.18	-1.82	54	62.83	34.85	10.18	55.68	132	19	Average
4874	53.67	-20.33	74	64.32	34.85	10.18	55.68	132	19	Peak

Test Mode :	802.11b Ant. 1	Temperature :	23~25°C
Test Channel :	06	Relative Humidity :	51~52%
Test Engineer :	Timberland and Kai Wang	Polarization :	Vertical
Remark :	1. 2437 MHz is Fundamental signal which can be ignored. 2. 3249 MHz is not within a restricted band, and its limit line is 20dB below the highest emission level.		

Frequency (MHz)	Level (dBμV/m)	Over Limit (dB)	Limit Line (dBμV/m)	Read Level (dBμV)	Antenna Factor (dB)	Cable Loss (dB)	Preamp Factor (dB)	Ant Pos (cm)	Table Pos (deg)	Remark
2437	93.21	-	-	92.29	30.02	5.46	34.56	106	284	Average
2437	97.9	-	-	96.98	30.02	5.46	34.56	106	284	Peak
3249	56.81	-21.09	77.9	69.94	33.1	7.82	54.05	100	0	Peak
4874	50.86	-23.14	74	61.51	34.85	10.18	55.68	100	0	Peak



Test Mode :	802.11b Ant. 1	Temperature :	23~25°C
Test Channel :	11	Relative Humidity :	51~52%
Test Engineer :	Timberland and Kai Wang	Polarization :	Horizontal
Remark :	1. 2462 MHz is fundamental signal which can be ignored. 2. 3282 MHz is not within a restricted band, and its limit line is 20dB below the highest emission level.		

Frequency (MHz)	Level (dBμV/m)	Over Limit (dB)	Limit Line (dBμV/m)	Read Level (dBμV)	Antenna Factor (dB)	Cable Loss (dB)	Preamp Factor (dB)	Ant Pos (cm)	Table Pos (deg)	Remark
2462	90.91	-	-	89.97	30.01	5.49	34.56	100	130	Average
2462	95.45	-	-	94.51	30.01	5.49	34.56	100	130	Peak
3282	55.32	-20.13	75.45	68.44	33.1	7.84	54.06	100	0	Peak
4924	50.86	-23.14	74	61.6	34.83	10.21	55.78	100	0	Peak

Test Mode :	802.11b Ant. 1	Temperature :	23~25°C
Test Channel :	11	Relative Humidity :	51~52%
Test Engineer :	Timberland and Kai Wang	Polarization :	Vertical
Remark :	1. 2462 MHz is fundamental signal which can be ignored. 2. 3282 MHz is not within a restricted band, and its limit line is 20dB below the highest emission level.		

Frequency (MHz)	Level (dBμV/m)	Over Limit (dB)	Limit Line (dBμV/m)	Read Level (dBμV)	Antenna Factor (dB)	Cable Loss (dB)	Preamp Factor (dB)	Ant Pos (cm)	Table Pos (deg)	Remark
2462	94.03	-	-	93.09	30.01	5.49	34.56	102	286	Average
2462	98.65	-	-	97.71	30.01	5.49	34.56	102	286	Peak
3282	58.02	-20.63	78.65	71.14	33.1	7.84	54.06	100	0	Peak
4924	50.22	-23.78	74	60.96	34.83	10.21	55.78	100	0	Peak



Test Mode :	802.11g Ant. 0	Temperature :	23~25°C
Test Channel :	01	Relative Humidity :	51~52%
Test Engineer :	Timberland and Kai Wang	Polarization :	Horizontal
Remark :	1. 2412 MHz is fundamental signal which can be ignored. 2. 3216 MHz and 7236MHz are not within a restricted band, and its limit line is 20dB below the highest emission level.		

Frequency (MHz)	Level (dBμV/m)	Over Limit (dB)	Limit Line (dBμV/m)	Read Level (dBμV)	Antenna Factor (dB)	Cable Loss (dB)	Preamp Factor (dB)	Ant Pos (cm)	Table Pos (deg)	Remark
2412	87.29	-	-	84.51	31.91	5.43	34.56	100	338	Average
2412	99.65	-	-	96.87	31.91	5.43	34.56	100	338	Peak
3216	51.82	-27.83	79.65	69.05	30.46	6.35	54.04	100	0	Peak
4824	39.78	-14.22	54	53.67	33.74	7.96	55.59	100	80	Average
4824	52.78	-21.22	74	66.67	33.74	7.96	55.59	100	80	Peak
7236	56.29	-23.36	79.65	62.02	39.67	11.02	56.42	100	66	Peak

Test Mode :	802.11g Ant. 0	Temperature :	23~25°C
Test Channel :	01	Relative Humidity :	51~52%
Test Engineer :	Timberland and Kai Wang	Polarization :	Vertical
Remark :	1. 2412 MHz is fundamental signal which can be ignored. 2. 3216 MHz is not within a restricted band, and its limit line is 20dB below the highest emission level.		

Frequency (MHz)	Level (dBμV/m)	Over Limit (dB)	Limit Line (dBμV/m)	Read Level (dBμV)	Antenna Factor (dB)	Cable Loss (dB)	Preamp Factor (dB)	Ant Pos (cm)	Table Pos (deg)	Remark
2412	91.62	-	-	88.84	31.91	5.43	34.56	100	293	Average
2412	103.86	-	-	101.08	31.91	5.43	34.56	100	293	Peak
3216	52.82	-31.04	83.86	67.41	33.1	6.35	54.04	100	0	Peak
4824	40.83	-13.17	54	53.59	34.87	7.96	55.59	100	333	Average
4824	54.03	-19.97	74	66.79	34.87	7.96	55.59	100	333	Peak



Test Mode :	802.11g Ant. 0	Temperature :	23~25°C
Test Channel :	06	Relative Humidity :	51~52%
Test Engineer :	Timberland and Kai Wang	Polarization :	Horizontal
Remark :	1. 2437 MHz is fundamental signal which can be ignored. 2. 3249 MHz is not within a restricted band, and its limit line is 20dB below the highest emission level.		

Frequency (MHz)	Level (dBμV/m)	Over Limit (dB)	Limit Line (dBμV/m)	Read Level (dBμV)	Antenna Factor (dB)	Cable Loss (dB)	Preamp Factor (dB)	Ant Pos (cm)	Table Pos (deg)	Remark
133.41	29.41	-14.09	43.5	48.15	11.56	1.4	31.7	-	-	Peak
231.96	33.89	-12.11	46	52.89	10.42	2.18	31.6	-	-	Peak
253.83	34	-12	46	50.52	12.92	2.24	31.68	-	-	Peak
666.8	33.09	-12.91	46	42.47	19.14	3.46	31.98	-	-	Peak
800.5	42.13	-3.87	46	50.66	20	3.44	31.97	100	169	Peak
865.6	38.49	-7.51	46	45.99	20.45	3.86	31.81	-	-	Peak
2437	86.59	-	-	83.74	31.95	5.46	34.56	120	38	Average
2437	98.34	-	-	95.49	31.95	5.46	34.56	120	38	Peak
3249	53.29	-25.05	78.34	70.49	30.45	6.4	54.05	100	0	Peak
4874	40.79	-13.21	54	54.53	33.94	8	55.68	101	301	Average
4874	53.16	-20.84	74	66.9	33.94	8	55.68	101	301	Peak
7311	42.39	-11.61	54	47.63	39.92	11.12	56.28	100	346	Average
7311	56.39	-17.61	74	61.63	39.92	11.12	56.28	100	346	Peak



Test Mode :	802.11g Ant. 0	Temperature :	23~25°C
Test Channel :	06	Relative Humidity :	51~52%
Test Engineer :	Timberland and Kai Wang	Polarization :	Vertical
Remark :	1. 2437 MHz is fundamental signal which can be ignored. 2. 3249 MHz is not within a restricted band, and its limit line is 20dB below the highest emission level.		

Frequency (MHz)	Level (dBμV/m)	Over Limit (dB)	Limit Line (dBμV/m)	Read Level (dBμV)	Antenna Factor (dB)	Cable Loss (dB)	Preamp Factor (dB)	Ant Pos (cm)	Table Pos (deg)	Remark
46.74	28.16	-11.84	40	49.93	9.33	0.6	31.7	-	-	Peak
133.41	30.15	-13.35	43.5	48.89	11.56	1.4	31.7	-	-	Peak
230.61	30.9	-15.1	46	50.02	10.31	2.17	31.6	-	-	Peak
533.1	33.95	-12.05	46	44.59	18.25	2.96	31.85	-	-	Peak
800.5	36.72	-9.28	46	45.25	20	3.44	31.97	100	274	Peak
933.5	36.04	-9.96	46	42.79	20.73	3.8	31.28	-	-	Peak
2437	90.29	-	-	87.44	31.95	5.46	34.56	100	293	Average
2437	101.97	-	-	99.14	31.93	5.46	34.56	100	293	Peak
3249	53.76	-28.21	81.97	68.31	33.1	6.4	54.05	100	0	Peak
4874	41.91	-12.09	54	54.74	34.85	8	55.68	100	333	Average
4874	54.98	-19.02	74	67.81	34.85	8	55.68	100	333	Peak



Test Mode :	802.11g Ant. 0	Temperature :	23~25°C
Test Channel :	11	Relative Humidity :	51~52%
Test Engineer :	Timberland and Kai Wang	Polarization :	Horizontal
Remark :	1. 2462 MHz is fundamental signal which can be ignored. 2. 3282 MHz is not within a restricted band, and its limit line is 20dB below the highest emission level.		

Frequency (MHz)	Level (dBμV/m)	Over Limit (dB)	Limit Line (dBμV/m)	Read Level (dBμV)	Antenna Factor (dB)	Cable Loss (dB)	Preamp Factor (dB)	Ant Pos (cm)	Table Pos (deg)	Remark
2462	84.53	-	-	81.63	31.97	5.49	34.56	100	38	Average
2462	97.06	-	-	94.16	31.97	5.49	34.56	100	38	Peak
3282	54.35	-22.71	77.06	71.54	30.44	6.43	54.06	100	0	Peak
4924	41.34	-12.66	54	54.94	34.14	8.04	55.78	101	54	Average
4924	54.66	-19.34	74	68.26	34.14	8.04	55.78	101	54	Peak
7386	41.16	-12.84	54	45.82	40.23	11.22	56.11	100	42	Average
7386	56.91	-17.09	74	61.57	40.23	11.22	56.11	100	42	Peak

Test Mode :	802.11g Ant. 0	Temperature :	23~25°C
Test Channel :	11	Relative Humidity :	51~52%
Test Engineer :	Timberland and Kai Wang	Polarization :	Vertical
Remark :	1. 2462 MHz is fundamental signal which can be ignored. 2. 3282 MHz is not within a restricted band, and its limit line is 20dB below the highest emission level.		

Frequency (MHz)	Level (dBμV/m)	Over Limit (dB)	Limit Line (dBμV/m)	Read Level (dBμV)	Antenna Factor (dB)	Cable Loss (dB)	Preamp Factor (dB)	Ant Pos (cm)	Table Pos (deg)	Remark
2462	88.77	-	-	85.87	31.97	5.49	34.56	100	241	Average
2462	100.32	-	-	97.42	31.97	5.49	34.56	100	241	Peak
3282	51.95	-28.37	80.32	66.48	33.1	6.43	54.06	100	0	Peak
4924	42.25	-11.75	54	55.16	34.83	8.04	55.78	100	332	Average
4924	54.31	-19.69	74	67.22	34.83	8.04	55.78	100	332	Peak
7386	38.24	-15.76	54	47.01	36.12	11.22	56.11	100	86	Average
7386	53.02	-20.98	74	61.79	36.12	11.22	56.11	100	86	Peak



Test Mode :	802.11g Ant. 1	Temperature :	23~25°C
Test Channel :	01	Relative Humidity :	51~52%
Test Engineer :	Timberland and Kai Wang	Polarization :	Horizontal
Remark :	1. 2412 MHz is fundamental signal which can be ignored. 2. 3216 MHz is not within a restricted band, and its limit line is 20dB below the highest emission level.		

Frequency (MHz)	Level (dBμV/m)	Over Limit (dB)	Limit Line (dBμV/m)	Read Level (dBμV)	Antenna Factor (dB)	Cable Loss (dB)	Preamp Factor (dB)	Ant Pos (cm)	Table Pos (deg)	Remark
2412	81.09	-	-	80.19	30.03	5.43	34.56	100	180	Average
2412	93.37	-	-	92.47	30.03	5.43	34.56	100	180	Peak
3216	51.71	-21.66	73.37	65.27	32.7	7.78	54.04	100	0	Peak
4824	52.44	-1.56	54	63.43	34.43	10.17	55.59	117	18	Average
4824	67.69	-6.31	74	78.68	34.43	10.17	55.59	117	18	Peak

Test Mode :	802.11g Ant. 1	Temperature :	23~25°C
Test Channel :	01	Relative Humidity :	51~52%
Test Engineer :	Timberland and Kai Wang	Polarization :	Vertical
Remark :	1. 2412 MHz is fundamental signal which can be ignored. 2. 3216 MHz is not within a restricted band, and its limit line is 20dB below the highest emission level.		

Frequency (MHz)	Level (dBμV/m)	Over Limit (dB)	Limit Line (dBμV/m)	Read Level (dBμV)	Antenna Factor (dB)	Cable Loss (dB)	Preamp Factor (dB)	Ant Pos (cm)	Table Pos (deg)	Remark
2412	85.4	-	-	84.5	30.03	5.43	34.56	105	282	Average
2412	96.42	-	-	95.52	30.03	5.43	34.56	105	282	Peak
3216	55.22	-21.2	76.42	68.78	32.7	7.78	54.04	100	0	Peak
4824	49.75	-4.25	54	60.74	34.43	10.17	55.59	100	44	Average
4824	62.68	-11.32	74	73.67	34.43	10.17	55.59	100	44	Peak



Test Mode :	802.11g Ant. 1	Temperature :	23~25°C
Test Channel :	06	Relative Humidity :	51~52%
Test Engineer :	Timberland and Kai Wang	Polarization :	Horizontal
Remark :	1. 2437 MHz is fundamental signal which can be ignored. 2. 3249 MHz is not within a restricted band, and its limit line is 20dB below the highest emission level.		

Frequency (MHz)	Level (dBμV/m)	Over Limit (dB)	Limit Line (dBμV/m)	Read Level (dBμV)	Antenna Factor (dB)	Cable Loss (dB)	Preamp Factor (dB)	Ant Pos (cm)	Table Pos (deg)	Remark
2437	81	-	-	80.08	30.02	5.46	34.56	100	175	Average
2437	92.23	-	-	91.3	30.03	5.46	34.56	100	175	Peak
3249	54.22	-18.01	72.23	67.35	33.1	7.82	54.05	100	0	Peak
4874	52.57	-1.43	54	63.22	34.85	10.18	55.68	134	19	Average
4874	62.3	-11.7	74	72.95	34.85	10.18	55.68	134	19	Peak

Test Mode :	802.11g Ant. 1	Temperature :	23~25°C
Test Channel :	06	Relative Humidity :	51~52%
Test Engineer :	Timberland and Kai Wang	Polarization :	Vertical
Remark :	1. 2437 MHz is fundamental signal which can be ignored. 2. 3249 MHz is not within a restricted band, and its limit line is 20dB below the highest emission level.		

Frequency (MHz)	Level (dBμV/m)	Over Limit (dB)	Limit Line (dBμV/m)	Read Level (dBμV)	Antenna Factor (dB)	Cable Loss (dB)	Preamp Factor (dB)	Ant Pos (cm)	Table Pos (deg)	Remark
2437	86.05	-	-	85.13	30.02	5.46	34.56	130	270	Average
2437	98.47	-	-	97.54	30.03	5.46	34.56	130	270	Peak
3249	55.97	-22.5	78.47	69.1	33.1	7.82	54.05	100	0	Peak
4874	50.84	-3.16	54	61.49	34.85	10.18	55.68	100	31	Average
4874	60.73	-13.27	74	71.38	34.85	10.18	55.68	100	31	Peak



Test Mode :	802.11g Ant. 1	Temperature :	23~25°C
Test Channel :	11	Relative Humidity :	51~52%
Test Engineer :	Timberland and Kai Wang	Polarization :	Horizontal
Remark :	1. 2462 MHz is fundamental signal which can be ignored. 2. 3282 MHz is not within a restricted band, and its limit line is 20dB below the highest emission level.		

Frequency (MHz)	Level (dBμV/m)	Over Limit (dB)	Limit Line (dBμV/m)	Read Level (dBμV)	Antenna Factor (dB)	Cable Loss (dB)	Preamp Factor (dB)	Ant Pos (cm)	Table Pos (deg)	Remark
2462	82.31	-	-	81.37	30.01	5.49	34.56	100	130	Average
2462	93.67	-	-	92.73	30.01	5.49	34.56	100	130	Peak
3282	54.37	-19.3	73.67	67.49	33.1	7.84	54.06	100	0	Peak
4924	52.77	-1.23	54	63.51	34.83	10.21	55.78	116	18	Average
4924	62.88	-11.12	74	73.62	34.83	10.21	55.78	116	18	Peak

Test Mode :	802.11g Ant. 1	Temperature :	23~25°C
Test Channel :	11	Relative Humidity :	51~52%
Test Engineer :	Timberland and Kai Wang	Polarization :	Vertical
Remark :	1. 2462 MHz is fundamental signal which can be ignored. 2. 3282 MHz is not within a restricted band, and its limit line is 20dB below the highest emission level.		

Frequency (MHz)	Level (dBμV/m)	Over Limit (dB)	Limit Line (dBμV/m)	Read Level (dBμV)	Antenna Factor (dB)	Cable Loss (dB)	Preamp Factor (dB)	Ant Pos (cm)	Table Pos (deg)	Remark
2462	85.33	-	-	84.39	30.01	5.49	34.56	104	286	Average
2462	97.17	-	-	96.23	30.01	5.49	34.56	104	286	Peak
3282	57.24	-19.93	77.17	70.36	33.1	7.84	54.06	100	0	Peak
4924	50.75	-3.25	54	61.49	34.83	10.21	55.78	100	32	Average
4924	60.84	-13.16	74	71.58	34.83	10.21	55.78	100	32	Peak



Test Mode :	802.11n-HT20 Ant. 0	Temperature :	23~25°C
Test Channel :	01	Relative Humidity :	51~52%
Test Engineer :	Timberland and Kai Wang	Polarization :	Horizontal
Remark :	1. 2412 MHz is fundamental signal which can be ignored. 2. 3216 MHz is not within a restricted band, and its limit line is 20dB below the highest emission level.		

Frequency (MHz)	Level (dBμV/m)	Over Limit (dB)	Limit Line (dBμV/m)	Read Level (dBμV)	Antenna Factor (dB)	Cable Loss (dB)	Preamp Factor (dB)	Ant Pos (cm)	Table Pos (deg)	Remark
2412	79.98	-	-	79.08	30.03	5.43	34.56	100	6	Average
2412	99.96	-	-	99.06	30.03	5.43	34.56	100	6	Peak
3216	53.32	-26.64	79.96	70.55	30.46	6.35	54.04	100	0	Peak
4824	39.01	-14.99	54	52.9	33.74	7.96	55.59	100	83	Average
4824	51.22	-22.78	74	65.11	33.74	7.96	55.59	100	83	Peak

Test Mode :	802.11n-HT20 Ant. 0	Temperature :	23~25°C
Test Channel :	01	Relative Humidity :	51~52%
Test Engineer :	Timberland and Kai Wang	Polarization :	Vertical
Remark :	1. 2412 MHz is fundamental signal which can be ignored. 2. 3216 MHz is not within a restricted band, and its limit line is 20dB below the highest emission level.		

Frequency (MHz)	Level (dBμV/m)	Over Limit (dB)	Limit Line (dBμV/m)	Read Level (dBμV)	Antenna Factor (dB)	Cable Loss (dB)	Preamp Factor (dB)	Ant Pos (cm)	Table Pos (deg)	Remark
2412	80.67	-	-	79.77	30.03	5.43	34.56	105	298	Average
2412	100.24	-	-	99.34	30.03	5.43	34.56	105	298	Peak
3216	52.69	-27.55	80.24	67.28	33.1	6.35	54.04	100	0	Peak
4824	39.48	-14.52	54	52.24	34.87	7.96	55.59	101	333	Average
4824	52.66	-21.34	74	65.42	34.87	7.96	55.59	101	333	Peak



Test Mode :	802.11n-HT20 Ant. 0	Temperature :	23~25°C
Test Channel :	06	Relative Humidity :	51~52%
Test Engineer :	Timberland and Kai Wang	Polarization :	Horizontal
Remark :	1. 2437 MHz is fundamental signal which can be ignored. 2. 3249 MHz is not within a restricted band, and its limit line is 20dB below the highest emission level.		

Frequency (MHz)	Level (dBμV/m)	Over Limit (dB)	Limit Line (dBμV/m)	Read Level (dBμV)	Antenna Factor (dB)	Cable Loss (dB)	Preamp Factor (dB)	Ant Pos (cm)	Table Pos (deg)	Remark
133.41	29.54	-13.96	43.5	48.28	11.56	1.4	31.7	-	-	Peak
233.58	34.62	-11.38	46	53.41	10.64	2.19	31.62	-	-	Peak
250.05	34.37	-11.63	46	51.34	12.4	2.28	31.65	-	-	Peak
666.8	34.23	-11.77	46	43.61	19.14	3.46	31.98	-	-	Peak
799.8	42.06	-3.94	46	50.59	20	3.44	31.97	100	127	Peak
933.5	33.71	-12.29	46	40.46	20.73	3.8	31.28	-	-	Peak
2437	79.34	-	-	78.42	30.02	5.46	34.56	100	11	Average
2437	98.66	-	-	97.73	30.03	5.46	34.56	100	11	Peak
3249	53.93	-24.73	78.66	71.13	30.45	6.4	54.05	100	0	Peak
4874	39.33	-14.67	54	53.07	33.94	8	55.68	100	166	Average
4874	52.33	-21.67	74	66.07	33.94	8	55.68	100	166	Peak



Test Mode :	802.11n-HT20 Ant. 0	Temperature :	23~25°C
Test Channel :	06	Relative Humidity :	51~52%
Test Engineer :	Timberland and Kai Wang	Polarization :	Vertical
Remark :	1. 2437 MHz is fundamental signal which can be ignored. 2. 3249 MHz is not within a restricted band, and its limit line is 20dB below the highest emission level.		

Frequency (MHz)	Level (dBμV/m)	Over Limit (dB)	Limit Line (dBμV/m)	Read Level (dBμV)	Antenna Factor (dB)	Cable Loss (dB)	Preamp Factor (dB)	Ant Pos (cm)	Table Pos (deg)	Remark
46.74	28.05	-11.95	40	49.82	9.33	0.6	31.7	-	-	Peak
133.41	30.24	-13.26	43.5	48.98	11.56	1.4	31.7	-	-	Peak
230.88	30.88	-15.12	46	50	10.31	2.17	31.6	-	-	Peak
466.6	34.85	-11.15	46	46.87	17.16	2.64	31.82	100	159	Peak
533.1	30.99	-15.01	46	41.63	18.25	2.96	31.85	-	-	Peak
933.5	34.72	-11.28	46	41.47	20.73	3.8	31.28	-	-	Peak
2437	80.2	-	-	79.28	30.02	5.46	34.56	103	260	Average
2437	100.08	-	-	99.16	30.02	5.46	34.56	103	260	Peak
3249	53.63	-26.45	80.08	68.18	33.1	6.4	54.05	100	0	Peak
4874	40.93	-13.07	54	53.76	34.85	8	55.68	102	331	Average
4874	52.65	-21.35	74	65.48	34.85	8	55.68	102	331	Peak



Test Mode :	802.11n-HT20 Ant. 0	Temperature :	23~25°C
Test Channel :	11	Relative Humidity :	51~52%
Test Engineer :	Timberland and Kai Wang	Polarization :	Horizontal
Remark :	1. 2462 MHz is fundamental signal which can be ignored. 2. 3282 MHz is not within a restricted band, and its limit line is 20dB below the highest emission level.		

Frequency (MHz)	Level (dBμV/m)	Over Limit (dB)	Limit Line (dBμV/m)	Read Level (dBμV)	Antenna Factor (dB)	Cable Loss (dB)	Preamp Factor (dB)	Ant Pos (cm)	Table Pos (deg)	Remark
2462	77.93	-	-	75.03	31.97	5.49	34.56	100	38	Average
2462	96.32	-	-	93.42	31.97	5.49	34.56	100	38	Peak
3282	54.65	-21.67	76.32	71.84	30.44	6.43	54.06	100	0	Peak
4924	40.37	-13.63	54	53.97	34.14	8.04	55.78	100	311	Average
4924	53.4	-20.6	74	67	34.14	8.04	55.78	100	311	Peak

Test Mode :	802.11n-HT20 Ant. 0	Temperature :	23~25°C
Test Channel :	11	Relative Humidity :	51~52%
Test Engineer :	Timberland and Kai Wang	Polarization :	Vertical
Remark :	1. 2462 MHz is fundamental signal which can be ignored. 2. 3282 MHz is not within a restricted band, and its limit line is 20dB below the highest emission level.		

Frequency (MHz)	Level (dBμV/m)	Over Limit (dB)	Limit Line (dBμV/m)	Read Level (dBμV)	Antenna Factor (dB)	Cable Loss (dB)	Preamp Factor (dB)	Ant Pos (cm)	Table Pos (deg)	Remark
2462	80.99	-	-	78.09	31.97	5.49	34.56	100	246	Average
2462	100.39	-	-	97.49	31.97	5.49	34.56	100	246	Peak
3282	50.03	-30.36	80.39	64.56	33.1	6.43	54.06	100	0	Peak
4924	41.18	-12.82	54	54.09	34.83	8.04	55.78	100	334	Average
4924	53.92	-20.08	74	66.83	34.83	8.04	55.78	100	334	Peak



Test Mode :	802.11n-HT20 Ant. 1	Temperature :	23~25°C
Test Channel :	01	Relative Humidity :	51~52%
Test Engineer :	Timberland and Kai Wang	Polarization :	Horizontal
Remark :	1. 2412 MHz is fundamental signal which can be ignored. 2. 3216 MHz is not within a restricted band, and its limit line is 20dB below the highest emission level.		

Frequency (MHz)	Level (dBμV/m)	Over Limit (dB)	Limit Line (dBμV/m)	Read Level (dBμV)	Antenna Factor (dB)	Cable Loss (dB)	Preamp Factor (dB)	Ant Pos (cm)	Table Pos (deg)	Remark
2412	73.87	-	-	72.97	30.03	5.43	34.56	100	176	Average
2412	92.61	-	-	91.71	30.03	5.43	34.56	100	176	Peak
3216	51.84	-20.77	72.61	65	33.1	7.78	54.04	100	0	Peak
4824	52.87	-1.13	54	63.42	34.87	10.17	55.59	133	19	Average
4824	63.63	-10.37	74	74.18	34.87	10.17	55.59	133	19	Peak

Test Mode :	802.11n-HT20 Ant. 1	Temperature :	23~25°C
Test Channel :	01	Relative Humidity :	51~52%
Test Engineer :	Timberland and Kai Wang	Polarization :	Vertical
Remark :	1. 2412 MHz is fundamental signal which can be ignored. 2. 3216 MHz is not within a restricted band, and its limit line is 20dB below the highest emission level.		

Frequency (MHz)	Level (dBμV/m)	Over Limit (dB)	Limit Line (dBμV/m)	Read Level (dBμV)	Antenna Factor (dB)	Cable Loss (dB)	Preamp Factor (dB)	Ant Pos (cm)	Table Pos (deg)	Remark
2412	78.14	-	-	77.24	30.03	5.43	34.56	107	284	Average
2412	97.21	-	-	96.31	30.03	5.43	34.56	107	284	Peak
3216	55.26	-21.95	77.21	68.42	33.1	7.78	54.04	100	0	Peak
4824	50.81	-3.19	54	61.36	34.87	10.17	55.59	100	29	Average
4824	65.98	-8.02	74	76.53	34.87	10.17	55.59	100	29	Peak
2412	78.14	24.14	54	77.24	30.03	5.43	34.56	107	284	Average



Test Mode :	802.11n-HT20 Ant. 1	Temperature :	23~25°C
Test Channel :	06	Relative Humidity :	51~52%
Test Engineer :	Timberland and Kai Wang	Polarization :	Horizontal
Remark :	1. 2437 MHz is fundamental signal which can be ignored. 2. 3249 MHz is not within a restricted band, and its limit line is 20dB below the highest emission level.		

Frequency (MHz)	Level (dBμV/m)	Over Limit (dB)	Limit Line (dBμV/m)	Read Level (dBμV)	Antenna Factor (dB)	Cable Loss (dB)	Preamp Factor (dB)	Ant Pos (cm)	Table Pos (deg)	Remark
2437	74.08	-	-	73.16	30.02	5.46	34.56	100	176	Average
2437	92.05	-	-	91.13	30.02	5.46	34.56	100	176	Peak
3249	50.01	-22.04	72.05	63.14	33.1	7.82	54.05	100	0	Peak
4874	52.9	-1.1	54	63.55	34.85	10.18	55.68	115	314	Average
4874	66.86	-7.14	74	77.51	34.85	10.18	55.68	115	314	Peak

Test Mode :	802.11n-HT20 Ant. 1	Temperature :	23~25°C
Test Channel :	06	Relative Humidity :	51~52%
Test Engineer :	Timberland and Kai Wang	Polarization :	Vertical
Remark :	1. 2437 MHz is fundamental signal which can be ignored. 2. 3249 MHz is not within a restricted band, and its limit line is 20dB below the highest emission level.		

Frequency (MHz)	Level (dBμV/m)	Over Limit (dB)	Limit Line (dBμV/m)	Read Level (dBμV)	Antenna Factor (dB)	Cable Loss (dB)	Preamp Factor (dB)	Ant Pos (cm)	Table Pos (deg)	Remark
2437	77.61	-	-	76.69	30.02	5.46	34.56	109	271	Average
2437	96.91	-	-	95.99	30.02	5.46	34.56	109	271	Peak
3249	54.52	-22.39	76.91	67.65	33.1	7.82	54.05	100	0	Peak
4874	50.48	-3.52	54	61.13	34.85	10.18	55.68	100	36	Average
4874	65.86	-8.14	74	76.51	34.85	10.18	55.68	100	36	Peak



Test Mode :	802.11n-HT20 Ant. 1	Temperature :	23~25°C
Test Channel :	11	Relative Humidity :	51~52%
Test Engineer :	Timberland and Kai Wang	Polarization :	Horizontal
Remark :	1. 2462 MHz is fundamental signal which can be ignored. 2. 3282 MHz is not within a restricted band, and its limit line is 20dB below the highest emission level.		

Frequency (MHz)	Level (dBμV/m)	Over Limit (dB)	Limit Line (dBμV/m)	Read Level (dBμV)	Antenna Factor (dB)	Cable Loss (dB)	Preamp Factor (dB)	Ant Pos (cm)	Table Pos (deg)	Remark
2462	75.37	-	-	74.43	30.01	5.49	34.56	100	131	Average
2462	93.41	-	-	92.47	30.01	5.49	34.56	100	131	Peak
3282	51.5	-21.91	73.41	64.62	33.1	7.84	54.06	100	0	Peak
4924	52.72	-1.28	54	63.46	34.83	10.21	55.78	115	310	Average
4924	65.9	-8.1	74	76.64	34.83	10.21	55.78	115	310	Peak

Test Mode :	802.11n-HT20 Ant. 1	Temperature :	23~25°C
Test Channel :	11	Relative Humidity :	51~52%
Test Engineer :	Timberland and Kai Wang	Polarization :	Vertical
Remark :	1. 2462 MHz is fundamental signal which can be ignored. 2. 3282 MHz is not within a restricted band, and its limit line is 20dB below the highest emission level.		

Frequency (MHz)	Level (dBμV/m)	Over Limit (dB)	Limit Line (dBμV/m)	Read Level (dBμV)	Antenna Factor (dB)	Cable Loss (dB)	Preamp Factor (dB)	Ant Pos (cm)	Table Pos (deg)	Remark
2462	78.24	-	-	77.3	30.01	5.49	34.56	103	287	Average
2462	97.43	-	-	96.49	30.01	5.49	34.56	103	287	Peak
3282	53.96	-23.47	77.43	67.08	33.1	7.84	54.06	100	0	Peak
4924	49.43	-4.57	54	60.17	34.83	10.21	55.78	100	36	Average
4924	62.8	-11.2	74	73.54	34.83	10.21	55.78	100	36	Peak



Test Mode :	802.11n-HT20 Ant. 0+1	Temperature :	23~25°C
Test Channel :	01	Relative Humidity :	51~52%
Test Engineer :	Timberland and Kai Wang	Polarization :	Horizontal
Remark :	1. 2412 MHz is fundamental signal which can be ignored. 2. 3216 MHz is not within a restricted band, and its limit line is 20dB below the highest emission level.		

Frequency (MHz)	Level (dBμV/m)	Over Limit (dB)	Limit Line (dBμV/m)	Read Level (dBμV)	Antenna Factor (dB)	Cable Loss (dB)	Preamp Factor (dB)	Ant Pos (cm)	Table Pos (deg)	Remark
2412	77.78	-	-	76.88	30.03	5.43	34.56	100	8	Average
2412	97.1	-	-	96.2	30.03	5.43	34.56	100	8	Peak
3216	55.28	-21.82	77.1	68.44	33.1	7.78	54.04	100	0	Peak
4824	50.42	-3.58	54	60.97	34.87	10.17	55.59	124	19	Average
4824	64.86	-9.14	74	75.41	34.87	10.17	55.59	124	19	Peak



Test Mode :	802.11n-HT20 Ant. 0+1	Temperature :	23~25°C
Test Channel :	01	Relative Humidity :	51~52%
Test Engineer :	Timberland and Kai Wang	Polarization :	Vertical
Remark :	1. 2412 MHz is fundamental signal which can be ignored. 2. 3216 MHz is not within a restricted band, and its limit line is 20dB below the highest emission level		

Frequency (MHz)	Level (dBμV/m)	Over Limit (dB)	Limit Line (dBμV/m)	Read Level (dBμV)	Antenna Factor (dB)	Cable Loss (dB)	Preamp Factor (dB)	Ant Pos (cm)	Table Pos (deg)	Remark
2412	79.62	-	-	78.72	30.03	5.43	34.56	106	270	Average
2412	99.83	-	-	98.93	30.03	5.43	34.56	106	270	Peak
3216	52.63	-27.2	79.83	65.79	33.1	7.78	54.04	100	0	Peak
4824	48.79	-5.21	54	59.34	34.87	10.17	55.59	100	346	Average
4824	63.62	-10.38	74	74.17	34.87	10.17	55.59	100	346	Peak



Test Mode :	802.11n-HT20 Ant. 0+1	Temperature :	23~25°C
Test Channel :	06	Relative Humidity :	51~52%
Test Engineer :	Timberland and Kai Wang	Polarization :	Horizontal
Remark :	1. 2437 MHz is fundamental signal which can be ignored. 2. 3249 MHz is not within a restricted band, and its limit line is 20dB below the highest emission level		

Frequency (MHz)	Level (dBμV/m)	Over Limit (dB)	Limit Line (dBμV/m)	Read Level (dBμV)	Antenna Factor (dB)	Cable Loss (dB)	Preamp Factor (dB)	Ant Pos (cm)	Table Pos (deg)	Remark
133.41	29.29	-14.21	43.5	48.03	11.56	1.4	31.7	-	-	Peak
230.88	35.72	-10.28	46	54.84	10.31	2.17	31.6	-	-	Peak
250.05	33.77	-12.23	46	50.74	12.4	2.28	31.65	-	-	Peak
666.8	34.36	-11.64	46	43.74	19.14	3.46	31.98	-	-	Peak
800.5	40.72	-5.28	46	49.25	20	3.44	31.97	106	39	Peak
867.7	37.13	-8.87	46	44.6	20.48	3.85	31.8	-	-	Peak
2437	77.26	-	-	76.34	30.02	5.46	34.56	100	8	Average
2437	96.46	-	-	95.54	30.02	5.46	34.56	100	8	Peak
3249	55.73	-20.73	76.46	68.86	33.1	7.82	54.05	100	0	Peak
4874	50.58	-3.42	54	61.23	34.85	10.18	55.68	116	304	Average
4874	64.09	-9.91	74	74.74	34.85	10.18	55.68	116	304	Peak



Test Mode :	802.11n-HT20 Ant. 0+1	Temperature :	23~25°C
Test Channel :	06	Relative Humidity :	51~52%
Test Engineer :	Timberland and Kai Wang	Polarization :	Vertical
Remark :	1. 2437 MHz is fundamental signal which can be ignored. 2. 3249 MHz is not within a restricted band, and its limit line is 20dB below the highest emission level		

Frequency (MHz)	Level (dBμV/m)	Over Limit (dB)	Limit Line (dBμV/m)	Read Level (dBμV)	Antenna Factor (dB)	Cable Loss (dB)	Preamp Factor (dB)	Ant Pos (cm)	Table Pos (deg)	Remark
47.28	28.48	-11.52	40	50.46	9.1	0.62	31.7	100	214	Peak
133.41	30.33	-13.17	43.5	49.07	11.56	1.4	31.7	-	-	Peak
233.58	32.42	-13.58	46	51.21	10.64	2.19	31.62	-	-	Peak
533.1	31.07	-14.93	46	41.71	18.25	2.96	31.85	-	-	Peak
609.4	30.46	-15.54	46	40.57	18.89	3.1	32.1	-	-	Peak
867	32.82	-13.18	46	40.3	20.47	3.85	31.8	-	-	Peak
2437	77.69	-	-	76.77	30.02	5.46	34.56	104	261	Average
2437	98.49	-	-	97.57	30.02	5.46	34.56	104	261	Peak
3249	53.05	-25.44	78.49	66.18	33.1	7.82	54.05	100	0	Peak
4874	48.78	-5.22	54	59.43	34.85	10.18	55.68	100	33	Average
4874	63.16	-10.84	74	73.81	34.85	10.18	55.68	100	33	Peak



Test Mode :	802.11n-HT20 Ant. 0+1	Temperature :	23~25°C
Test Channel :	11	Relative Humidity :	51~52%
Test Engineer :	Timberland and Kai Wang	Polarization :	Horizontal
Remark :	1. 2462 MHz is fundamental signal which can be ignored. 2. 3282 MHz is not within a restricted band, and its limit line is 20dB below the highest emission level.		

Frequency (MHz)	Level (dBμV/m)	Over Limit (dB)	Limit Line (dBμV/m)	Read Level (dBμV)	Antenna Factor (dB)	Cable Loss (dB)	Preamp Factor (dB)	Ant Pos (cm)	Table Pos (deg)	Remark
2462	74.91	-	-	73.97	30.01	5.49	34.56	100	37	Average
2462	93.69	-	-	92.75	30.01	5.49	34.56	100	37	Peak
3282	56.32	-17.37	73.69	69.44	33.1	7.84	54.06	100	0	Peak
4924	49.81	-4.19	54	60.55	34.83	10.21	55.78	115	303	Average
4924	64.03	-9.97	74	74.77	34.83	10.21	55.78	115	303	Peak

Test Mode :	802.11n-HT20 Ant. 0+1	Temperature :	23~25°C
Test Channel :	11	Relative Humidity :	51~52%
Test Engineer :	Timberland and Kai Wang	Polarization :	Vertical
Remark :	3. 2462 MHz is fundamental signal which can be ignored. 4. 3282 MHz is not within a restricted band, and its limit line is 20dB below the highest emission level.		

Frequency (MHz)	Level (dBμV/m)	Over Limit (dB)	Limit Line (dBμV/m)	Read Level (dBμV)	Antenna Factor (dB)	Cable Loss (dB)	Preamp Factor (dB)	Ant Pos (cm)	Table Pos (deg)	Remark
2462	76.76	-	-	75.82	30.01	5.49	34.56	104	236	Average
2462	96.17	-	-	95.23	30.01	5.49	34.56	104	236	Peak
3282	52.65	-23.52	76.17	65.77	33.1	7.84	54.06	100	0	Peak
4924	46.67	-7.33	54	57.41	34.83	10.21	55.78	100	36	Average
4924	60.52	-13.48	74	71.26	34.83	10.21	55.78	100	36	Peak



Test Mode :	802.11n-HT40 Ant. 0	Temperature :	23~25°C
Test Channel :	03	Relative Humidity :	51~52%
Test Engineer :	Timberland and Kai Wang	Polarization :	Horizontal
Remark :	1. 2422 MHz is fundamental signal which can be ignored. 2. 3216 MHz is not within a restricted band, and its limit line is 20dB below the highest emission level.		

Frequency (MHz)	Level (dBμV/m)	Over Limit (dB)	Limit Line (dBμV/m)	Read Level (dBμV)	Antenna Factor (dB)	Cable Loss (dB)	Preamp Factor (dB)	Ant Pos (cm)	Table Pos (deg)	Remark
2422	76.15	-	-	75.25	30.03	5.43	34.56	100	7	Average
2422	95.61	-	-	94.71	30.03	5.43	34.56	100	7	Peak
3216	52.05	-23.56	75.61	69.28	30.46	6.35	54.04	100	0	Peak
4844	39.51	-14.49	54	53.4	33.74	7.96	55.59	100	48	Average
4844	51.37	-22.63	74	65.26	33.74	7.96	55.59	100	48	Peak

Test Mode :	802.11n-HT40 Ant. 0	Temperature :	23~25°C
Test Channel :	03	Relative Humidity :	51~52%
Test Engineer :	Timberland and Kai Wang	Polarization :	Vertical
Remark :	1. 2422 MHz is fundamental signal which can be ignored. 2. 3216 MHz is not within a restricted band, and its limit line is 20dB below the highest emission level.		

Frequency (MHz)	Level (dBμV/m)	Over Limit (dB)	Limit Line (dBμV/m)	Read Level (dBμV)	Antenna Factor (dB)	Cable Loss (dB)	Preamp Factor (dB)	Ant Pos (cm)	Table Pos (deg)	Remark
2422	76.99	-	-	76.09	30.03	5.43	34.56	104	286	Average
2422	96.95	-	-	96.05	30.03	5.43	34.56	104	286	Peak
3216	51.1	-25.85	76.95	65.69	33.1	6.35	54.04	100	0	Peak
4844	42.57	-11.43	54	55.33	34.87	7.96	55.59	100	330	Average
4844	52.41	-21.59	74	65.17	34.87	7.96	55.59	100	330	Peak



Test Mode :	802.11n-HT40 Ant. 0	Temperature :	23~25°C
Test Channel :	06	Relative Humidity :	51~52%
Test Engineer :	Timberland and Kai Wang	Polarization :	Horizontal
Remark :	1. 2437 MHz is fundamental signal which can be ignored. 2. 3249 MHz is not within a restricted band, and its limit line is 20dB below the highest emission level.		

Frequency (MHz)	Level (dBμV/m)	Over Limit (dB)	Limit Line (dBμV/m)	Read Level (dBμV)	Antenna Factor (dB)	Cable Loss (dB)	Preamp Factor (dB)	Ant Pos (cm)	Table Pos (deg)	Remark
78.06	19.92	-20.08	40	43.9	6.8	0.92	31.7	-	-	Peak
133.41	29.22	-14.28	43.5	47.96	11.56	1.4	31.7	-	-	Peak
230.88	35.22	-10.78	46	54.34	10.31	2.17	31.6	-	-	Peak
400.1	32.98	-13.02	46	46.46	15.94	2.37	31.79	-	-	Peak
800.5	41.46	-4.54	46	49.99	20	3.44	31.97	103	86	Peak
857.2	36.89	-9.11	46	44.46	20.4	3.89	31.86	-	-	Peak
2437	74.47	-	-	73.55	30.02	5.46	34.56	100	10	Average
2437	94.14	-	-	93.21	30.03	5.46	34.56	100	10	Peak
3249	53.86	-20.28	74.14	71.06	30.45	6.4	54.05	100	0	Peak
4874	39.55	-14.45	54	53.29	33.94	8	55.68	100	167	Average
4874	51.91	-22.09	74	65.65	33.94	8	55.68	100	167	Peak



Test Mode :	802.11n-HT40 Ant. 0	Temperature :	23~25°C
Test Channel :	06	Relative Humidity :	51~52%
Test Engineer :	Timberland and Kai Wang	Polarization :	Vertical
Remark :	1. 2437 MHz is fundamental signal which can be ignored. 2. 3249 MHz is not within a restricted band, and its limit line is 20dB below the highest emission level.		

Frequency (MHz)	Level (dBμV/m)	Over Limit (dB)	Limit Line (dBμV/m)	Read Level (dBμV)	Antenna Factor (dB)	Cable Loss (dB)	Preamp Factor (dB)	Ant Pos (cm)	Table Pos (deg)	Remark
45.93	28.56	-11.44	40	50.1	9.57	0.59	31.7	100	219	Peak
133.41	30.21	-13.29	43.5	48.95	11.56	1.4	31.7	-	-	Peak
233.31	32.93	-13.07	46	51.72	10.64	2.19	31.62	-	-	Peak
460.3	32.07	-13.93	46	44.25	17.11	2.56	31.85	-	-	Peak
872.6	32.72	-13.28	46	40.12	20.53	3.84	31.77	-	-	Peak
933.5	32.46	-13.54	46	39.21	20.73	3.8	31.28	-	-	Peak
2437	75.42	-	-	74.5	30.02	5.46	34.56	104	261	Average
2437	94.7	-	-	93.77	30.03	5.46	34.56	104	261	Peak
3249	53	-21.4	74.4	67.55	33.1	6.4	54.05	100	0	Peak
4874	40.66	-13.34	54	53.49	34.85	8	55.68	100	332	Average
4874	52.45	-21.55	74	65.28	34.85	8	55.68	100	332	Peak



Test Mode :	802.11n-HT40 Ant. 0	Temperature :	23~25°C
Test Channel :	09	Relative Humidity :	51~52%
Test Engineer :	Timberland and Kai Wang	Polarization :	Horizontal
Remark :	1. 2452 MHz is fundamental signal which can be ignored. 2. 3282 MHz is not within a restricted band, and its limit line is 20dB below the highest emission level.		

Frequency (MHz)	Level (dBμV/m)	Over Limit (dB)	Limit Line (dBμV/m)	Read Level (dBμV)	Antenna Factor (dB)	Cable Loss (dB)	Preamp Factor (dB)	Ant Pos (cm)	Table Pos (deg)	Remark
2452	73.1	-	-	72.16	30.01	5.49	34.56	100	27	Average
2452	91.91	-	-	90.97	30.01	5.49	34.56	100	27	Peak
3282	55.41	-16.5	71.91	72.6	30.44	6.43	54.06	100	0	Peak
4904	40.89	-13.11	54	54.49	34.14	8.04	55.78	100	169	Average
4904	52.95	-21.05	74	66.55	34.14	8.04	55.78	100	169	Peak

Test Mode :	802.11n-HT40 Ant. 0	Temperature :	23~25°C
Test Channel :	09	Relative Humidity :	51~52%
Test Engineer :	Timberland and Kai Wang	Polarization :	Vertical
Remark :	1. 2452 MHz is fundamental signal which can be ignored. 2. 3282 MHz is not within a restricted band, and its limit line is 20dB below the highest emission level.		

Frequency (MHz)	Level (dBμV/m)	Over Limit (dB)	Limit Line (dBμV/m)	Read Level (dBμV)	Antenna Factor (dB)	Cable Loss (dB)	Preamp Factor (dB)	Ant Pos (cm)	Table Pos (deg)	Remark
2452	73.38	-	-	72.44	30.01	5.49	34.56	104	263	Average
2452	92.01	-	-	91.07	30.01	5.49	34.56	104	263	Peak
3282	54.29	-17.72	72.01	68.82	33.1	6.43	54.06	100	0	Peak
4904	41.21	-12.79	54	54.12	34.83	8.04	55.78	100	321	Average
4904	53.03	-20.97	74	65.94	34.83	8.04	55.78	100	321	Peak



Test Mode :	802.11n-HT40 Ant. 1	Temperature :	23~25°C
Test Channel :	03	Relative Humidity :	51~52%
Test Engineer :	Timberland and Kai Wang	Polarization :	Horizontal
Remark :	1. 2422 MHz is fundamental signal which can be ignored. 2. 3228 MHz is not within a restricted band, and its limit line is 20dB below the highest emission level.		

Frequency (MHz)	Level (dBμV/m)	Over Limit (dB)	Limit Line (dBμV/m)	Read Level (dBμV)	Antenna Factor (dB)	Cable Loss (dB)	Preamp Factor (dB)	Ant Pos (cm)	Table Pos (deg)	Remark
2422	72.04	-	-	71.14	30.03	5.43	34.56	100	129	Average
2422	91.23	-	-	90.33	30.03	5.43	34.56	100	129	Peak
3228	50.65	-20.58	71.23	63.79	33.1	7.8	54.04	100	0	Peak
4844	52.86	-1.14	54	63.45	34.86	10.17	55.62	130	20	Average
4844	69.34	-4.66	74	79.93	34.86	10.17	55.62	130	20	Peak

Test Mode :	802.11n-HT40 Ant. 1	Temperature :	23~25°C
Test Channel :	03	Relative Humidity :	51~52%
Test Engineer :	Timberland and Kai Wang	Polarization :	Vertical
Remark :	1. 2422 MHz is fundamental signal which can be ignored. 2. 3228 MHz is not within a restricted band, and its limit line is 20dB below the highest emission level.		

Frequency (MHz)	Level (dBμV/m)	Over Limit (dB)	Limit Line (dBμV/m)	Read Level (dBμV)	Antenna Factor (dB)	Cable Loss (dB)	Preamp Factor (dB)	Ant Pos (cm)	Table Pos (deg)	Remark
2422	74.69	-	-	73.79	30.03	5.43	34.56	106	282	Average
2422	93.73	-	-	92.83	30.03	5.43	34.56	106	282	Peak
3228	54.83	-18.9	73.73	67.97	33.1	7.8	54.04	100	0	Peak
4844	51.4	-2.6	54	61.99	34.86	10.17	55.62	100	35	Average
4844	68.29	-5.71	74	78.88	34.86	10.17	55.62	100	35	Peak



Test Mode :	802.11n-HT40 Ant. 1	Temperature :	23~25°C
Test Channel :	06	Relative Humidity :	51~52%
Test Engineer :	Timberland and Kai Wang	Polarization :	Horizontal
Remark :	1. 2437 MHz is fundamental signal which can be ignored. 2. 3249 MHz is not within a restricted band, and its limit line is 20dB below the highest emission level.		

Frequency (MHz)	Level (dBμV/m)	Over Limit (dB)	Limit Line (dBμV/m)	Read Level (dBμV)	Antenna Factor (dB)	Cable Loss (dB)	Preamp Factor (dB)	Ant Pos (cm)	Table Pos (deg)	Remark
133.41	28.39	-15.11	43.5	47.13	11.56	1.4	31.7	-	-	Peak
230.88	35.37	-10.63	46	54.49	10.31	2.17	31.6	-	-	Peak
250.05	36.78	-9.22	46	53.75	12.4	2.28	31.65	-	-	Peak
400.1	33.74	-12.26	46	47.22	15.94	2.37	31.79	-	-	Peak
800.5	42.49	-3.51	46	51.02	20	3.44	31.97	103	318	Peak
933.5	35.34	-10.66	46	42.09	20.73	3.8	31.28	-	-	Peak
2437	72.25	-	-	71.33	30.02	5.46	34.56	100	148	Average
2437	91.14	-	-	90.22	30.02	5.46	34.56	100	148	Peak
3249	49.86	-21.28	71.14	62.99	33.1	7.82	54.05	100	0	Peak
4874	52.99	-1.01	54	63.64	34.85	10.18	55.68	114	303	Average
4874	72.31	-1.69	74	82.96	34.85	10.18	55.68	114	303	Peak
7311	36.2	-17.8	54	45.4	36.14	10.94	56.28	116	28	Average
7311	54.37	-19.63	74	63.57	36.14	10.94	56.28	116	28	Peak



Test Mode :	802.11n-HT40 Ant. 1	Temperature :	23~25°C
Test Channel :	06	Relative Humidity :	51~52%
Test Engineer :	Timberland and Kai Wang	Polarization :	Vertical
Remark :	1. 2437 MHz is fundamental signal which can be ignored. 2. 3249 MHz is not within a restricted band, and its limit line is 20dB below the highest emission level.		

Frequency (MHz)	Level (dBμV/m)	Over Limit (dB)	Limit Line (dBμV/m)	Read Level (dBμV)	Antenna Factor (dB)	Cable Loss (dB)	Preamp Factor (dB)	Ant Pos (cm)	Table Pos (deg)	Remark
47.55	28.54	-11.46	40	50.52	9.1	0.62	31.7	100	138	Peak
133.41	30.85	-12.65	43.5	49.59	11.56	1.4	31.7	-	-	Peak
230.88	30.54	-15.46	46	49.66	10.31	2.17	31.6	-	-	Peak
461.7	31.42	-14.58	46	43.57	17.12	2.57	31.84	-	-	Peak
666.8	32.29	-13.71	46	41.67	19.14	3.46	31.98	-	-	Peak
867	32.44	-13.56	46	39.92	20.47	3.85	31.8	-	-	Peak
2437	74.57	-	-	73.65	30.02	5.46	34.56	104	286	Average
2437	93.64	-	-	92.72	30.02	5.46	34.56	104	286	Peak
3249	54.18	-19.46	73.64	67.31	33.1	7.82	54.05	100	0	Peak
4874	51.54	-2.46	54	62.19	34.85	10.18	55.68	100	35	Average



Test Mode :	802.11n-HT40 Ant. 1	Temperature :	23~25°C
Test Channel :	09	Relative Humidity :	51~52%
Test Engineer :	Timberland and Kai Wang	Polarization :	Horizontal
Remark :	1. 2452 MHz is fundamental signal which can be ignored. 2. 3270 MHz is not within a restricted band, and its limit line is 20dB below the highest emission level.		

Frequency (MHz)	Level (dBμV/m)	Over Limit (dB)	Limit Line (dBμV/m)	Read Level (dBμV)	Antenna Factor (dB)	Cable Loss (dB)	Preamp Factor (dB)	Ant Pos (cm)	Table Pos (deg)	Remark
2452	71.7	-	-	70.76	30.01	5.49	34.56	100	128	Average
2452	90.56	-	-	89.62	30.01	5.49	34.56	100	128	Peak
3270	51.66	-18.9	70.56	64.78	33.1	7.84	54.06	100	0	Peak
4904	52.7	-1.3	54	63.41	34.83	10.2	55.74	114	305	Average
4904	71.69	-2.31	74	82.4	34.83	10.2	55.74	114	305	Peak
7356	36.87	-17.13	54	46	36.13	10.92	56.18	114	37	Average
7356	53.7	-20.3	74	62.83	36.13	10.92	56.18	114	37	Peak

Test Mode :	802.11n-HT40 Ant. 1	Temperature :	23~25°C
Test Channel :	09	Relative Humidity :	51~52%
Test Engineer :	Timberland and Kai Wang	Polarization :	Vertical
Remark :	1. 2452 MHz is fundamental signal which can be ignored. 2. 3270 MHz is not within a restricted band, and its limit line is 20dB below the highest emission level.		

Frequency (MHz)	Level (dBμV/m)	Over Limit (dB)	Limit Line (dBμV/m)	Read Level (dBμV)	Antenna Factor (dB)	Cable Loss (dB)	Preamp Factor (dB)	Ant Pos (cm)	Table Pos (deg)	Remark
2452	74.75	-	-	73.81	30.01	5.49	34.56	103	287	Average
2452	94.25	-	-	93.31	30.01	5.49	34.56	103	287	Peak
3270	53.7	-20.55	74.25	66.82	33.1	7.84	54.06	100	0	Peak
4904	50.22	-3.78	54	60.93	34.83	10.2	55.74	100	34	Average
4904	69.03	-4.97	74	79.74	34.83	10.2	55.74	100	34	Peak



Test Mode :	802.11n-HT40 Ant. 0+1	Temperature :	23~25°C
Test Channel :	03	Relative Humidity :	51~52%
Test Engineer :	Timberland and Kai Wang	Polarization :	Horizontal
Remark :	1. 2422 MHz is fundamental signal which can be ignored. 2. 3228 MHz is not within a restricted band, and its limit line is 20dB below the highest emission level		

Frequency (MHz)	Level (dBμV/m)	Over Limit (dB)	Limit Line (dBμV/m)	Read Level (dBμV)	Antenna Factor (dB)	Cable Loss (dB)	Preamp Factor (dB)	Ant Pos (cm)	Table Pos (deg)	Remark
2422	74.57	-	-	73.67	30.03	5.43	34.56	100	6	Average
2422	94.56	-	-	93.66	30.03	5.43	34.56	100	6	Peak
3228	55.21	-19.35	74.56	68.35	33.1	7.8	54.04	100	0	Peak
4844	48.58	-5.42	54	59.17	34.86	10.17	55.62	115	301	Average
4844	67.94	-6.06	74	78.53	34.86	10.17	55.62	115	301	Peak

Test Mode :	802.11n-HT40 Ant. 0+1	Temperature :	23~25°C
Test Channel :	03	Relative Humidity :	51~52%
Test Engineer :	Timberland and Kai Wang	Polarization :	Vertical
Remark :	1. 2422 MHz is fundamental signal which can be ignored. 2. 3228 MHz is not within a restricted band, and its limit line is 20dB below the highest emission level		

Frequency (MHz)	Level (dBμV/m)	Over Limit (dB)	Limit Line (dBμV/m)	Read Level (dBμV)	Antenna Factor (dB)	Cable Loss (dB)	Preamp Factor (dB)	Ant Pos (cm)	Table Pos (deg)	Remark
2422	76.78	-	-	75.88	30.03	5.43	34.56	107	298	Average
2422	97.28	-	-	96.38	30.03	5.43	34.56	107	298	Peak
3228	52.19	-25.09	77.28	65.33	33.1	7.8	54.04	100	0	Peak
4844	47.32	-6.68	54	57.91	34.86	10.17	55.62	100	35	Average
4844	66.02	-7.98	74	76.61	34.86	10.17	55.62	100	35	Peak



Test Mode :	802.11n-HT40 Ant. 0+1	Temperature :	23~25°C
Test Channel :	06	Relative Humidity :	51~52%
Test Engineer :	Timberland and Kai Wang	Polarization :	Horizontal
Remark :	1. 2437 MHz is fundamental signal which can be ignored. 2. 3249 MHz is not within a restricted band, and its limit line is 20dB below the highest emission level.		

Frequency (MHz)	Level (dBμV/m)	Over Limit (dB)	Limit Line (dBμV/m)	Read Level (dBμV)	Antenna Factor (dB)	Cable Loss (dB)	Preamp Factor (dB)	Ant Pos (cm)	Table Pos (deg)	Remark
133.41	29.39	-14.11	43.5	48.13	11.56	1.4	31.7	-	-	Peak
230.88	34.37	-11.63	46	53.49	10.31	2.17	31.6	-	-	Peak
250.05	35.78	-10.22	46	52.75	12.4	2.28	31.65	-	-	Peak
400.1	34.74	-11.26	46	48.22	15.94	2.37	31.79	-	-	Peak
800.5	42.49	-3.51	46	51.02	20	3.44	31.97	103	318	Peak
933.5	36.34	-9.66	46	43.09	20.73	3.8	31.28	-	-	Peak
2437	73	-	-	72.08	30.02	5.46	34.56	100	8	Average
2437	93.92	-	-	93	30.02	5.46	34.56	100	8	Peak
3249	55.09	-18.83	73.92	68.22	33.1	7.82	54.05	100	0	Peak
4874	49.87	-4.13	54	60.52	34.85	10.18	55.68	116	39	Average
4874	70.63	-3.37	74	81.27	34.85	10.19	55.68	116	39	Peak



Test Mode :	802.11n-HT40 Ant. 0+1	Temperature :	23~25°C
Test Channel :	06	Relative Humidity :	51~52%
Test Engineer :	Timberland and Kai Wang	Polarization :	Vertical
Remark :	1. 2437 MHz is fundamental signal which can be ignored. 2. 3249 MHz is not within a restricted band, and its limit line is 20dB below the highest emission level.		

Frequency (MHz)	Level (dBμV/m)	Over Limit (dB)	Limit Line (dBμV/m)	Read Level (dBμV)	Antenna Factor (dB)	Cable Loss (dB)	Preamp Factor (dB)	Ant Pos (cm)	Table Pos (deg)	Remark
47.55	28.54	-11.46	40	50.52	9.1	0.62	31.7	100	138	Peak
133.41	30.85	-12.65	43.5	49.59	11.56	1.4	31.7	-	-	Peak
230.88	30.54	-15.46	46	49.66	10.31	2.17	31.6	-	-	Peak
461.7	32.42	-13.58	46	44.57	17.12	2.57	31.84	-	-	Peak
666.8	32.29	-13.71	46	41.67	19.14	3.46	31.98	-	-	Peak
867	33.44	-12.56	46	40.92	20.47	3.85	31.8	-	-	Peak
2437	74.59	-	-	73.67	30.02	5.46	34.56	103	267	Average
2437	95.22	-	-	94.3	30.02	5.46	34.56	103	267	Peak
3249	52.79	-22.43	75.22	65.92	33.1	7.82	54.05	100	0	Peak
4874	49.25	-4.75	54	59.9	34.85	10.18	55.68	100	36	Average
4874	68.71	-5.29	74	79.35	34.85	10.19	55.68	100	36	Peak



Test Mode :	802.11n-HT40 Ant. 0+1	Temperature :	23~25°C
Test Channel :	09	Relative Humidity :	51~52%
Test Engineer :	Timberland and Kai Wang	Polarization :	Horizontal
Remark :	1. 2452 MHz is fundamental signal which can be ignored. 2. 3270 MHz is not within a restricted band, and its limit line is 20dB below the highest emission level.		

Frequency (MHz)	Level (dBμV/m)	Over Limit (dB)	Limit Line (dBμV/m)	Read Level (dBμV)	Antenna Factor (dB)	Cable Loss (dB)	Preamp Factor (dB)	Ant Pos (cm)	Table Pos (deg)	Remark
2452	72.84	-	-	71.9	30.01	5.49	34.56	100	36	Average
2452	92.44	-	-	91.5	30.01	5.49	34.56	100	36	Peak
3270	56.45	-15.99	72.44	69.57	33.1	7.84	54.06	100	0	Peak
4904	49.65	-4.35	54	60.36	34.83	10.2	55.74	118	34	Average
4904	68.87	-5.13	74	79.58	34.83	10.2	55.74	118	34	Peak

Test Mode :	802.11n-HT40 Ant. 0+1	Temperature :	23~25°C
Test Channel :	09	Relative Humidity :	51~52%
Test Engineer :	Timberland and Kai Wang	Polarization :	Vertical
Remark :	1. 2452 MHz is fundamental signal which can be ignored. 2. 3270 MHz is not within a restricted band, and its limit line is 20dB below the highest emission level.		

Frequency (MHz)	Level (dBμV/m)	Over Limit (dB)	Limit Line (dBμV/m)	Read Level (dBμV)	Antenna Factor (dB)	Cable Loss (dB)	Preamp Factor (dB)	Ant Pos (cm)	Table Pos (deg)	Remark
2452	73.76	-	-	72.82	30.01	5.49	34.56	105	265	Average
2452	95.22	-	-	94.28	30.01	5.49	34.56	105	265	Peak
3270	53.21	-22.01	75.22	66.33	33.1	7.84	54.06	100	0	Peak
4904	48.92	-5.08	54	59.63	34.83	10.2	55.74	100	42	Average
4904	67.89	-6.11	74	78.6	34.83	10.2	55.74	100	42	Peak

3.6 AC Conducted Emission Measurement

3.6.1 Limit of AC Conducted Emission

For equipment that is designed to be connected to the public utility (AC) power line, the radio frequency voltage that is conducted back onto the AC power line on any frequency or frequencies within the band 150 KHz to 30 MHz shall not exceed the limits in the following table.

Frequency of Emission (MHz)	Conducted Limit (dBuV)	
	Quasi-Peak	Average
0.15-0.5	66 to 56*	56 to 46*
0.5-5	56	46
5-30	60	50

*Decreases with the logarithm of the frequency.

3.6.2 Measuring Instruments

See list of measuring instruments of this test report.

3.6.3 Test Procedures

1. The testing follows the guidelines in ANSI C63.10-2009 and fulfills ANSI C63.4-2003 test site requirement.
2. The EUT was placed 0.4 meter from the conducting wall of the shielding room, and it was kept at least 80 centimeters from any other grounded conducting surface.
3. Connect EUT to the power mains through a line impedance stabilization network (LISN).
4. All the support units are connecting to the other LISN.
5. The LISN provides 50 ohm coupling impedance for the measuring instrument.
6. The FCC states that a 50 ohm, 50 microhenry LISN should be used.
7. Both sides of AC line were checked for maximum conducted interference.
8. The frequency range from 150 KHz to 30 MHz was searched.
9. Set the test-receiver system to Peak Detect Function and specified bandwidth with Maximum Hold Mode.

3.6.4 Test Setup

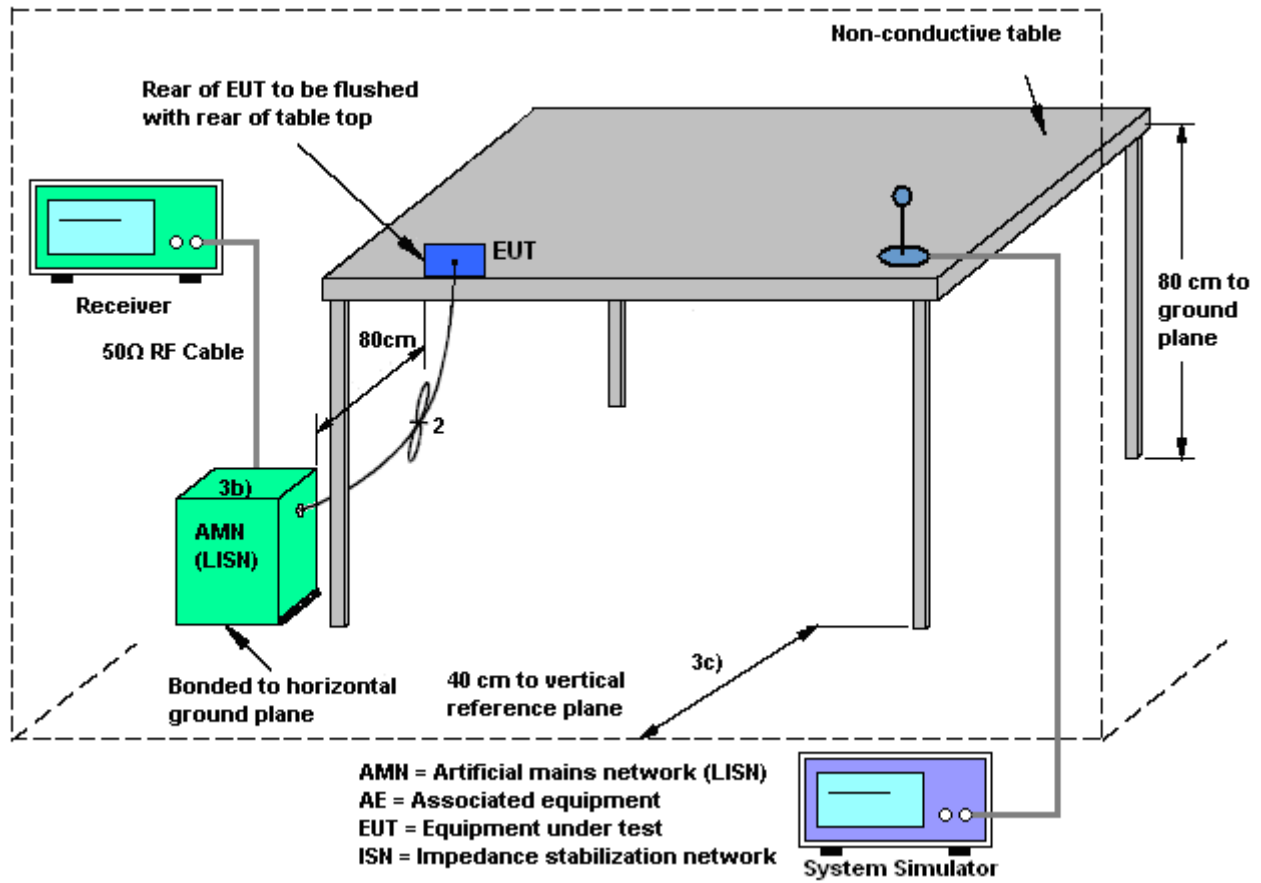

3.6.5 Test Result of AC Conducted Emission

Test Mode :	Mode 1	Temperature :	20~22°C
Test Engineer :	Kai-Chun Chu	Relative Humidity :	45~47%
Test Voltage :	120Vac / 60Hz	Phase :	Line
Function Type :	LTE Band 17 Idle + WLAN Link + LAN Link + WAN Link + USB 3.0 HD + Adapter		
Remark :	All emissions not reported here are more than 10 dB below the prescribed limit.		

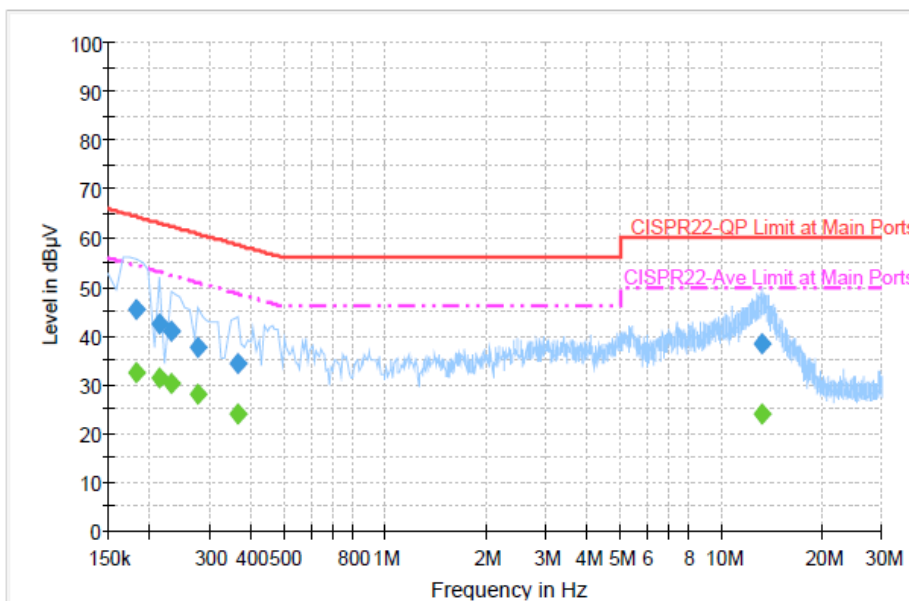

Final Result : QuasiPeak

Frequency (MHz)	QuasiPeak (dBµV)	Filter	Line	Corr. (dB)	Margin (dB)	Limit (dBµV)
0.182000	45.4	Off	L1	19.4	19.0	64.4
0.214000	42.5	Off	L1	19.4	20.5	63.0
0.230000	40.8	Off	L1	19.4	21.6	62.4
0.278000	37.6	Off	L1	19.3	23.3	60.9
0.366000	34.2	Off	L1	19.4	24.4	58.6
13.246000	38.5	Off	L1	19.8	21.5	60.0

Final Result : Average

Frequency (MHz)	Average (dBµV)	Filter	Line	Corr. (dB)	Margin (dB)	Limit (dBµV)
0.182000	32.6	Off	L1	19.4	21.8	54.4
0.214000	31.5	Off	L1	19.4	21.5	53.0
0.230000	30.1	Off	L1	19.4	22.3	52.4
0.278000	27.9	Off	L1	19.3	23.0	50.9
0.366000	24.0	Off	L1	19.4	24.6	48.6
13.246000	24.1	Off	L1	19.8	25.9	50.0

Test Mode :	Mode 1	Temperature :	20~22°C
Test Engineer :	Kai-Chun Chu	Relative Humidity :	45~47%
Test Voltage :	120Vac / 60Hz	Phase :	Neutral
Function Type :	LTE Band 17 Idle + WLAN Link + LAN Link + WAN Link + USB 3.0 HD + Adapter		
Remark :	All emissions not reported here are more than 10 dB below the prescribed limit.		

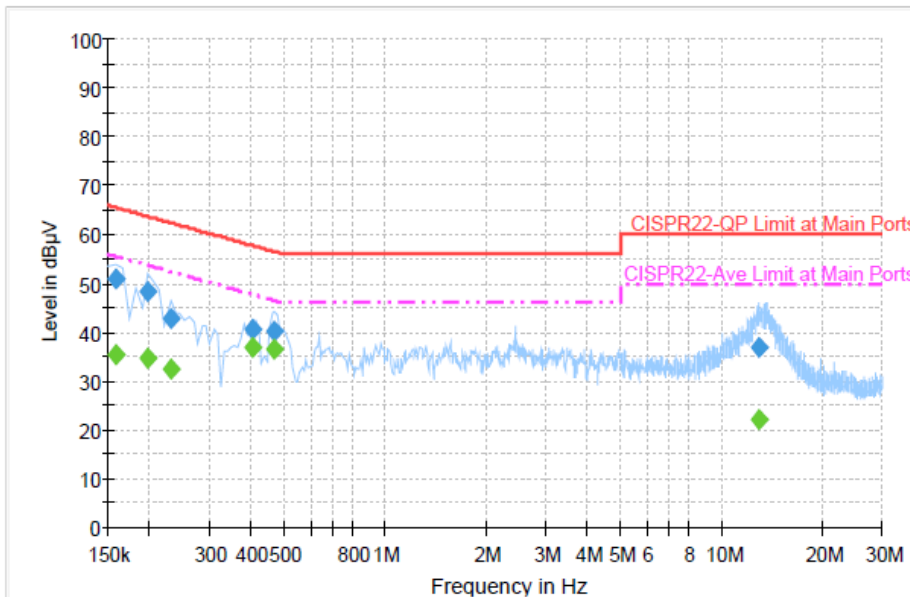

Final Result : QuasiPeak

Frequency (MHz)	QuasiPeak (dBµV)	Filter	Line	Corr. (dB)	Margin (dB)	Limit (dBµV)
0.158000	51.0	Off	N	19.3	14.6	65.6
0.198000	48.5	Off	N	19.3	15.2	63.7
0.230000	42.7	Off	N	19.4	19.7	62.4
0.406000	40.6	Off	N	19.4	17.1	57.7
0.470000	40.1	Off	N	19.4	16.4	56.5
12.950000	36.9	Off	N	19.8	23.1	60.0

Final Result : Average

Frequency (MHz)	Average (dBµV)	Filter	Line	Corr. (dB)	Margin (dB)	Limit (dBµV)
0.158000	35.6	Off	N	19.3	20.0	55.6
0.198000	34.7	Off	N	19.3	19.0	53.7
0.230000	32.6	Off	N	19.4	19.8	52.4
0.406000	37.0	Off	N	19.4	10.7	47.7
0.470000	36.7	Off	N	19.4	9.8	46.5
12.950000	22.3	Off	N	19.8	27.7	50.0

3.7 Antenna Requirements

3.7.1 Standard Applicable

If directional gain of transmitting Antennas is greater than 6dBi, the power shall be reduced by the same level in dB comparing to gain minus 6dBi. For the fixed point-to-point operation, the power shall be reduced by one dB for every 3 dB that the directional gain of the Antenna exceeds 6 dBi. The use of a permanently attached Antenna or of an Antenna that uses a unique coupling to the intentional radiator shall be considered sufficient to comply with the FCC rule.

3.7.2 Antenna Connected Construction

Non-standard connector used.

3.7.3 Antenna Gain

The EUT supports correlated MIMO mode. The composite antenna gain for 2.4GHz is 6.77 dBi. The antenna peak gain of EUT is over than 6 dBi. Therefore, it is necessary to reduce maximum peak output power and power density limit 0.77dB.

	2.4GHz
ANT. 0 GAIN (dBi)	4.20
ANT. 1 GAIN (dBi)	3.30
COMPOSITE GAIN (dBi)	6.77

FCC KDB 662911 D01 Multiple Transmitter Output v01r01

Unequal antenna gains, with equal transmit powers.

For antenna gains given by G_1, G_2, \dots, G_N dBi.

If transmit signals are *correlated*, then

$$\text{Directional gain} = 10 \log[(10^{G_1/20} + 10^{G_2/20} + \dots + 10^{G_N/20})/N] \text{ dBi}$$



4 List of Measuring Equipment

Instrument	Manufacturer	Model No.	Serial No.	Characteristics	Calibration Date	Test Date	Due Date	Remark
Spectrum Analyzer	R&S	FSP40	100055	9kHz~40GHz	Jun. 06, 2012	Aug. 07, 2012~ Sep. 06, 2012	Jun. 05, 2013	Conducted (TH02-HY)
Power Meter	Anritsu	ML2495A	0932001	N/A	Sep. 18, 2011	Aug. 07, 2012~ Sep. 06, 2012	Sep. 17, 2012	Conducted (TH02-HY)
Power Sensor	Anritsu	MA2411B	0846202	N/A	Sep. 18, 2011	Aug. 07, 2012~ Sep. 06, 2012	Sep. 17, 2012	Conducted (TH02-HY)
EMI Test Receiver	R&S	ESCS 30	100356	9KHz ~ 2.75GHz	Oct. 27, 2011	Aug. 07, 2012~ Sep. 06, 2012	Oct. 26, 2012	Conduction (CO05-HY)
Two-LISN	R&S	ENV216	11-100081	9KHz ~ 30MHz	Dec. 09, 2011	Aug. 07, 2012~ Sep. 06, 2012	Dec. 08, 2012	Conduction (CO05-HY)
Two-LISN	R&S	ENV216	11-100080	9KHz ~ 30MHz	Dec. 06, 2011	Aug. 07, 2012~ Sep. 06, 2012	Dec. 05, 2012	Conduction (CO05-HY)
AC Power Source	APC	APC-1000W	N/A	N/A	N/A	Aug. 07, 2012~ Sep. 06, 2012	N/A	Conduction (CO05-HY)
System Simulator	R&S	CMU200	117995	N/A	Jul. 28, 2011	Aug. 07, 2012~ Sep. 06, 2012	Jul. 27, 2013	Conduction (CO05-HY)
Spectrum Analyzer	Agilent	E4408B	MY442110 30	9KHz ~ 26.5GHz	Nov. 23, 2011	Aug. 10, 2012~ Aug. 25, 2012	Nov. 22, 2012	Radiation (03CH06-HY)
Spectrum Analyzer	R&S	FSP30	101352	9KHz-30GHz	Nov. 03, 2011	Aug. 10, 2012~ Aug. 25, 2012	Nov. 02, 2012	Radiation (03CH06-HY)
EMI Test Receiver	R&S	ESVS10	834468/00 3	20MHz ~ 1000MHz	May 04, 2012	Aug. 10, 2012~ Aug. 25, 2012	May. 03, 2013	Radiation (03CH06-HY)
Bilog Antenna	SCHAFFNER	CBL6112B	2885	30MHz ~ 2GHz	Oct. 22, 2011	Aug. 10, 2012~ Aug. 25, 2012	Oct. 21, 2012	Radiation (03CH06-HY)
Double Ridge Horn Antenna	EMCO	3117	00066583	1GHz ~ 18GHz	Aug. 01, 2012	Aug. 10, 2012~ Aug. 25, 2012	Jul. 31, 2013	Radiation (03CH06-HY)
SHF-EHF Horn Antenna	SCHWARZBE CK	BBHA 9170	BBHA9170 251	15GHz ~ 40GHz	Oct. 20, 2011	Aug. 10, 2012~ Aug. 25, 2012	Oct. 19, 2012	Radiation (03CH06-HY)
Preamplifier	Agilent	8449B	3008A019 17	1GHz ~ 26.5GHz	Apr. 13, 2012	Aug. 10, 2012~ Aug. 25, 2012	Apr. 12, 2013	Radiation (03CH06-HY)
Amplifier	Agilent	310N	186713	9KHz ~ 1GHz	Apr. 11, 2012	Aug. 10, 2012~ Aug. 25, 2012	Apr. 10, 2013	Radiation (03CH06-HY)
Pre Amplifier	EMCI	EMC051845	SN980048	1GHz ~ 18GHz	Jul. 21, 2012	Aug. 10, 2012~ Aug. 25, 2012	Jul. 20, 2013	Radiation (03CH06-HY)
Pre Amplifier	MITEQ	AMF-7D-0010 1800-30-10P	159087	1GHz~18GHz	Feb. 27, 2012	Aug. 10, 2012~ Aug. 25, 2012	Feb. 26, 2013	Radiation (03CH06-HY)
Loop Antenna	R&S	HFH2-Z2	100315	9KHz ~ 30MHz	May 14, 2012	Aug. 10, 2012~ Aug. 25, 2012	May 13, 2013	Radiation (03CH06-HY)



5 Uncertainty of Evaluation

Uncertainty of Conducted Emission Measurement (150KHz ~ 30MHz)

Measuring Uncertainty for a Level of Confidence of 95% (U = 2Uc(y))	2.26
---	------

Uncertainty of Radiated Emission Measurement (30MHz ~ 1000MHz)

Measuring Uncertainty for a Level of Confidence of 95% (U = 2Uc(y))	2.54
---	------

Uncertainty of Radiated Emission Measurement (1GHz ~ 40GHz)

Measuring Uncertainty for a Level of Confidence of 95% (U = 2Uc(y))	4.72
---	------



Appendix A. Photographs of EUT

Please refer to Sporton report number EP272508 as below.