

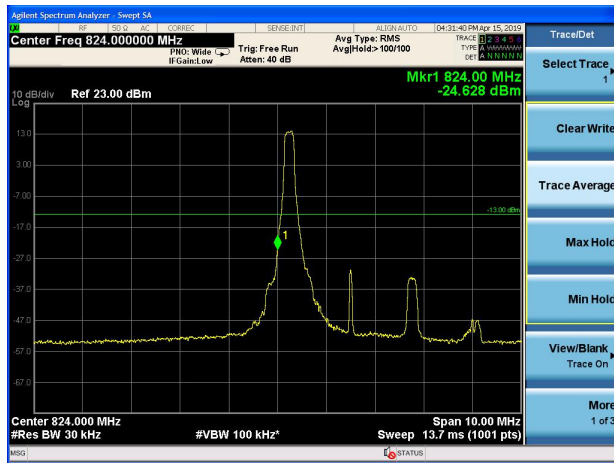

### LTE Band 5 QPSK 3MHz CH-Low 1RB

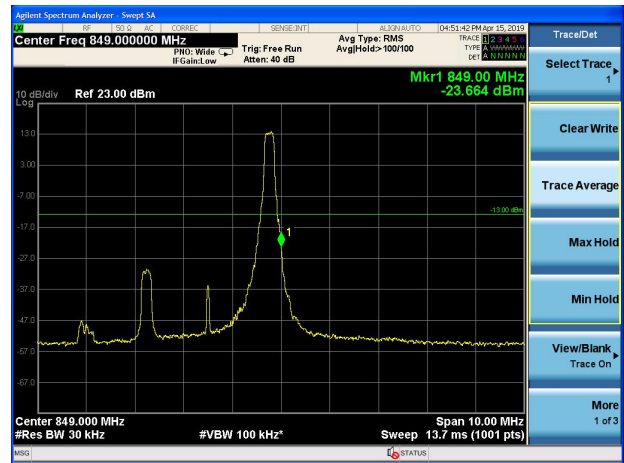

### LTE Band 5 QPSK 3MHz CH-High 1RB



### LTE Band 5 QPSK 3MHz CH-Low 100%RB

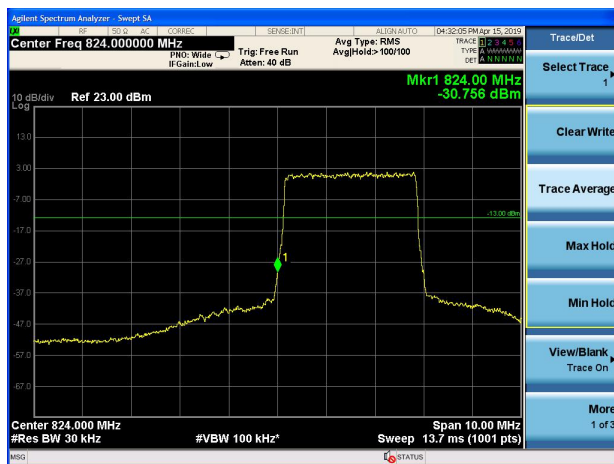

### LTE Band 5 QPSK 3MHz CH-High 100%RB

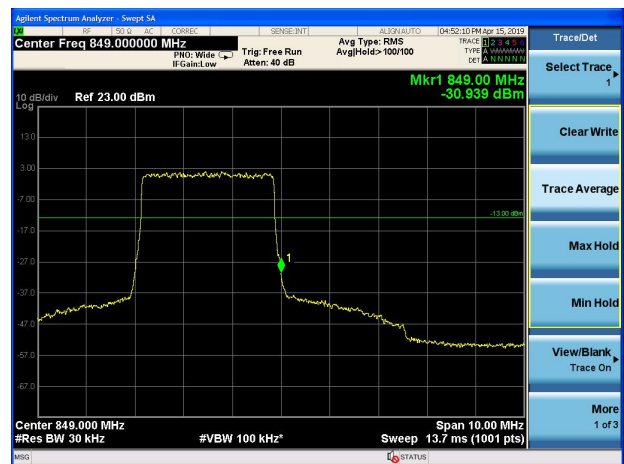

### LTE Band 5 QPSK 5MHz CH-Low 1RB

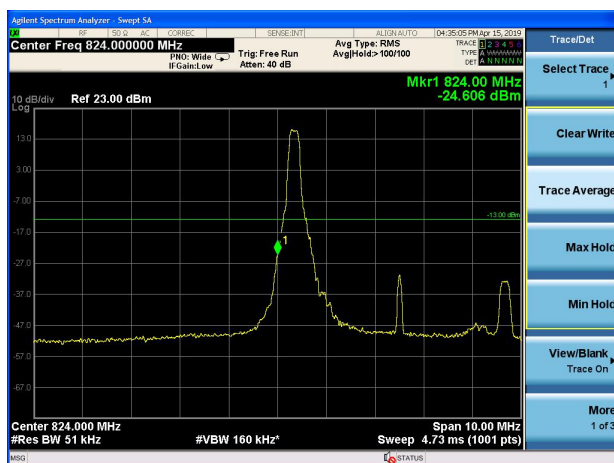

### LTE Band 5 QPSK 5MHz CH-High 1RB

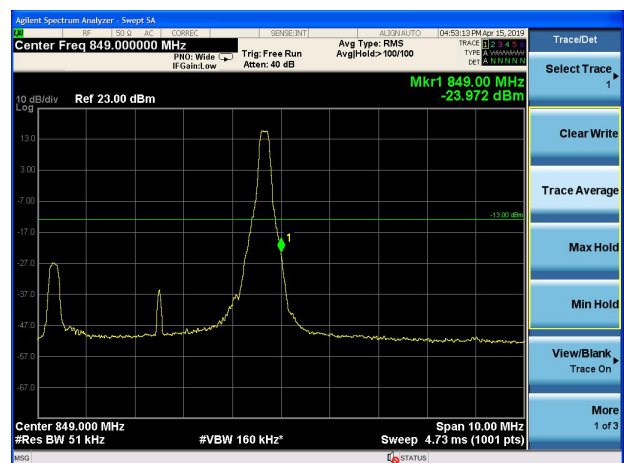



### LTE Band 5 QPSK 5MHz CH-Low 100%RB

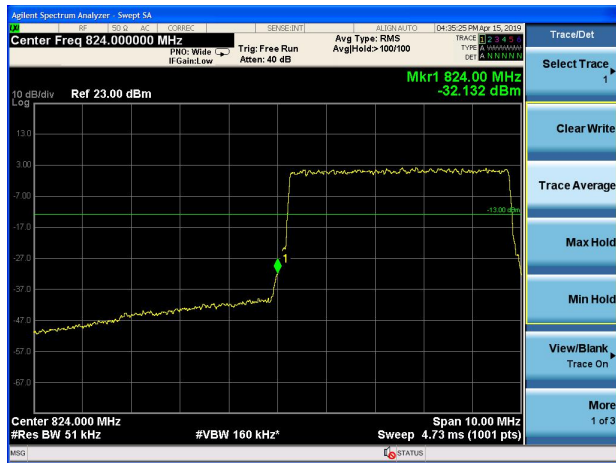

### LTE Band 5 QPSK 5MHz CH-High 100%RB



### LTE Band 5 QPSK 10MHz CH-Low 1RB

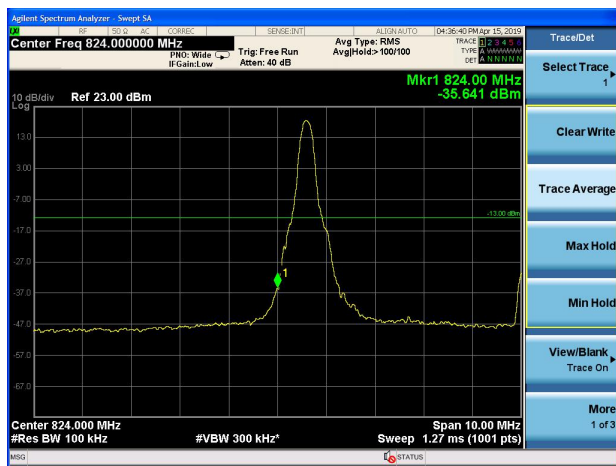

### LTE Band 5 QPSK 10MHz CH-High 1RB

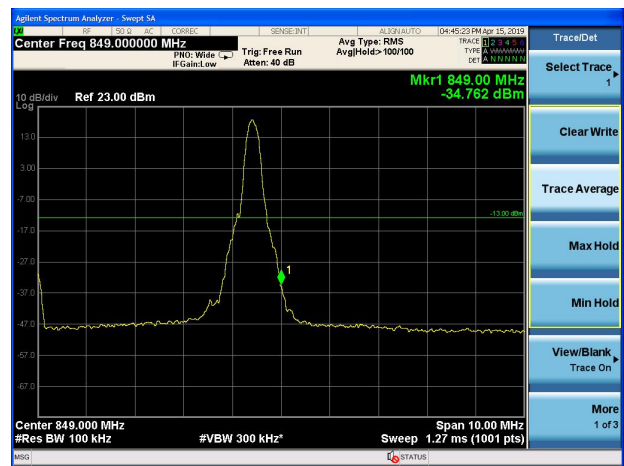

### LTE Band 5 QPSK 10MHz CH-Low 100%RB

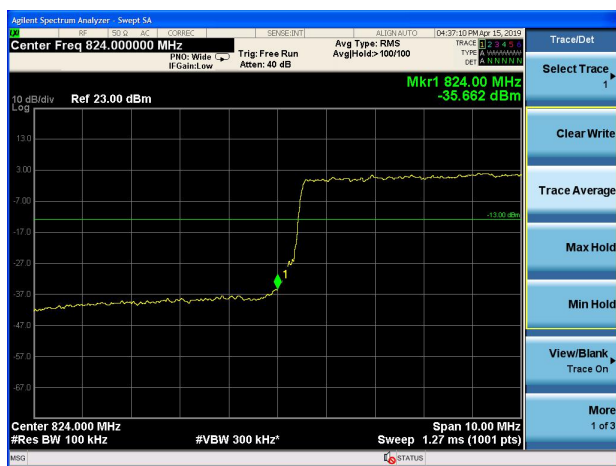

### LTE Band 5 QPSK 10MHz CH-High 100%RB

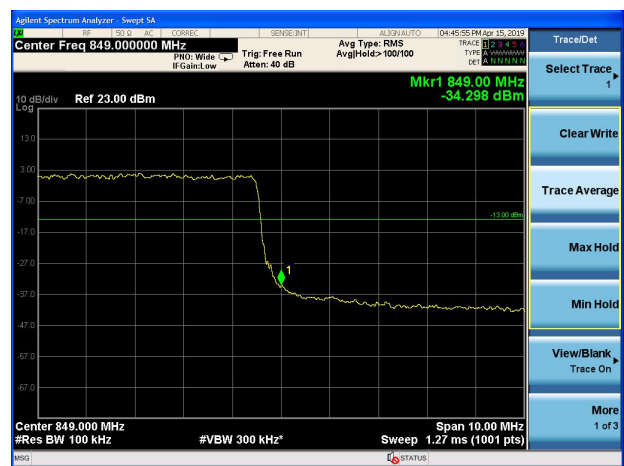



### LTE Band 5 16QAM 1.4MHz CH-Low 1RB

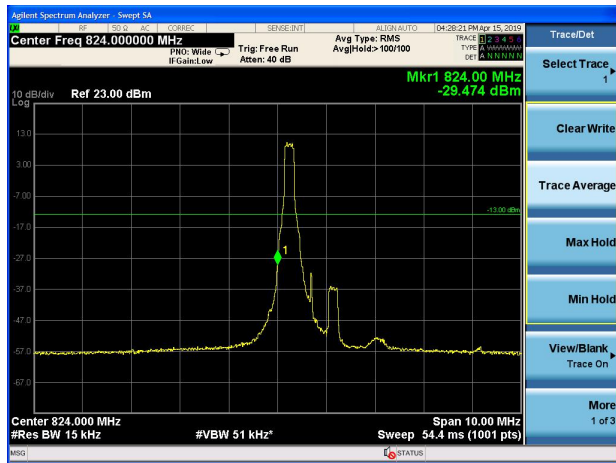

### LTE Band 5 16QAM 1.4MHz CH-High 1RB

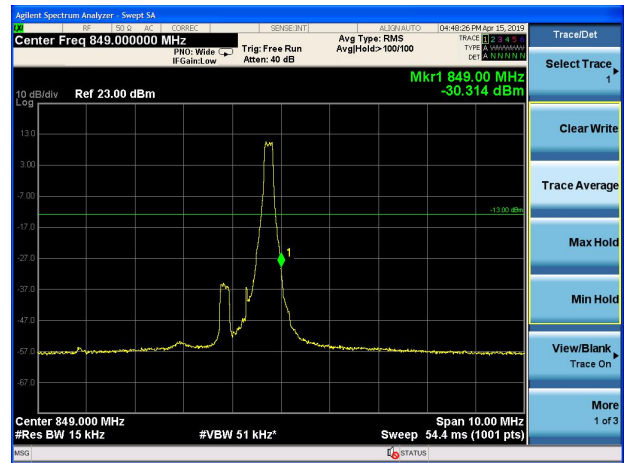

### LTE Band 5 16QAM 1.4MHz CH-Low 100%RB

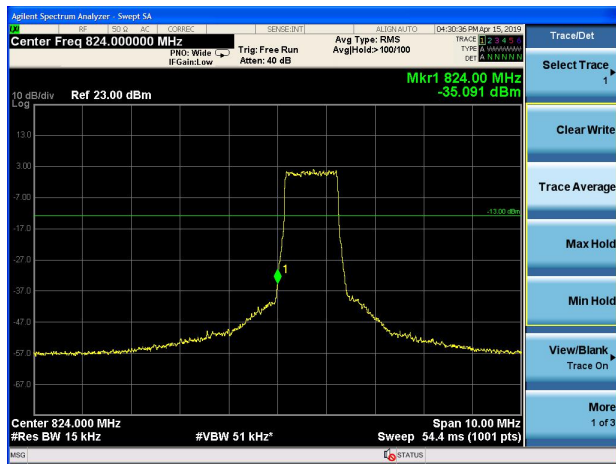

### LTE Band 5 16QAM 1.4MHz CH-High 100%RB

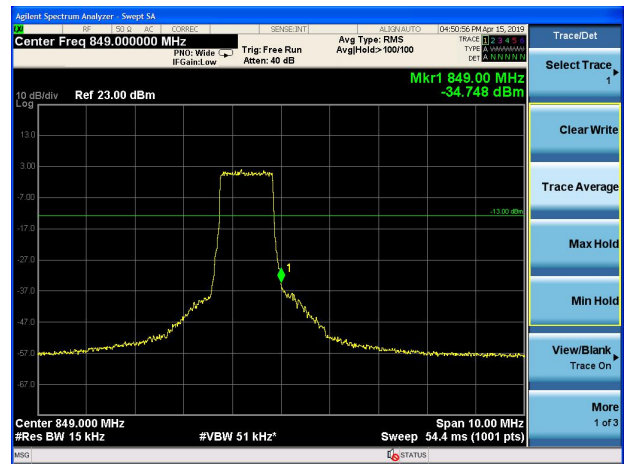

### LTE Band 5 16QAM 3MHz CH-Low 1RB

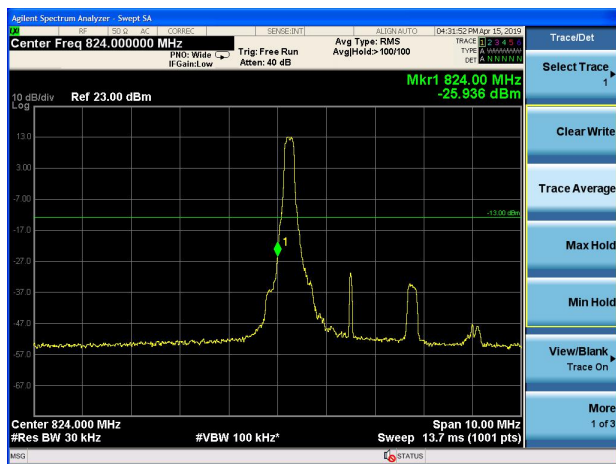

### LTE Band 5 16QAM 3MHz CH-High 1RB

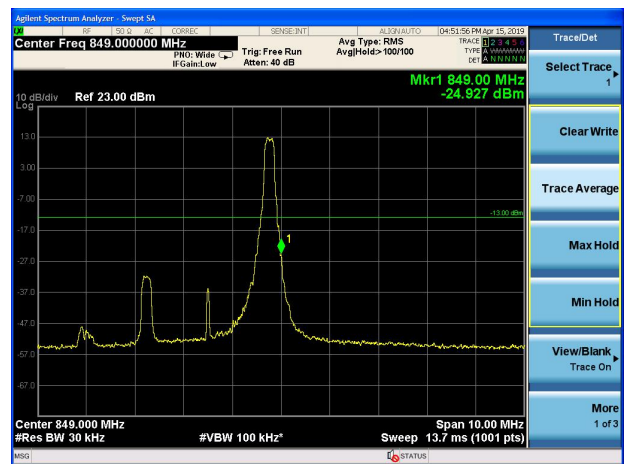



### LTE Band 5 16QAM 3MHz CH-Low 100%RB



### LTE Band 5 16QAM 3MHz CH-High 100%RB



### LTE Band 5 16QAM 5MHz CH-Low 1RB

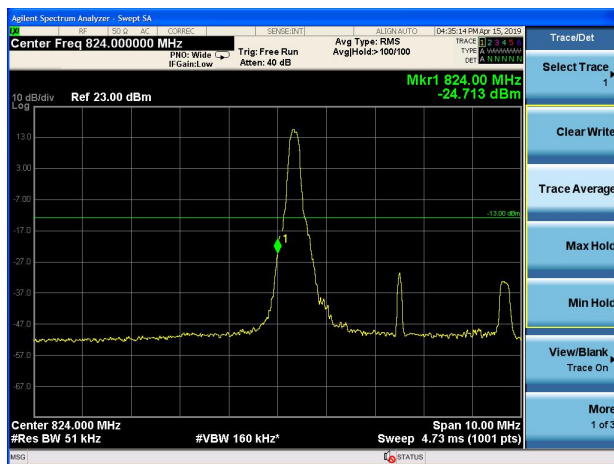

### LTE Band 5 16QAM 5MHz CH-High 1RB

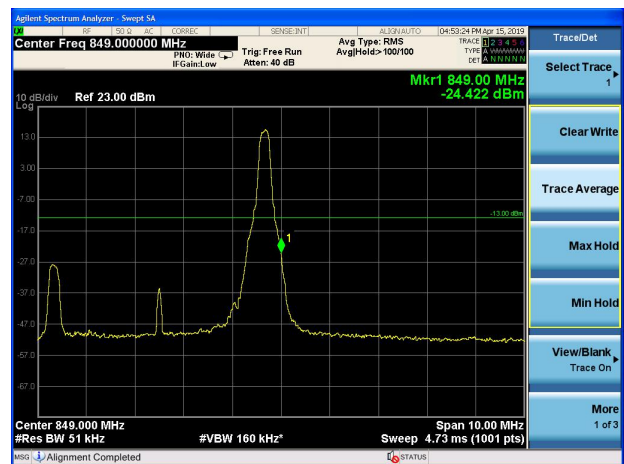

### LTE Band 5 16QAM 5MHz CH-Low 100%RB

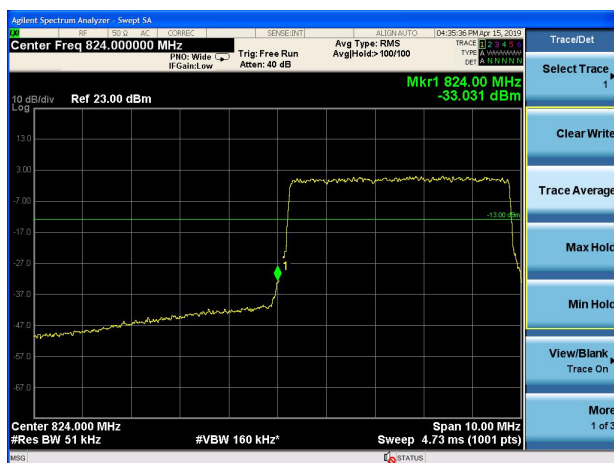

### LTE Band 5 16QAM 5MHz CH-High 100%RB





### LTE Band 5 16QAM 10MHz CH-Low 1RB

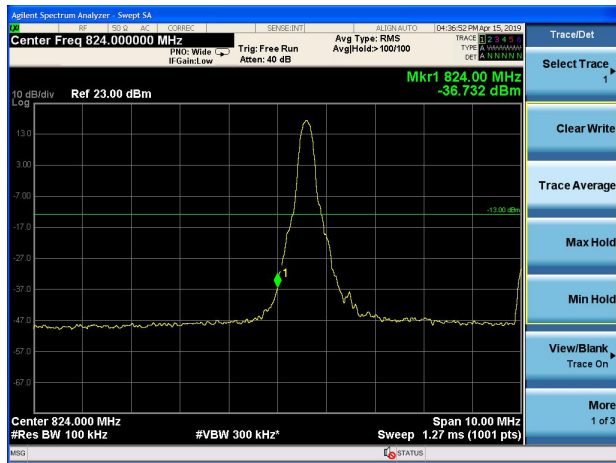

### LTE Band 5 16QAM 10MHz CH-High 1RB

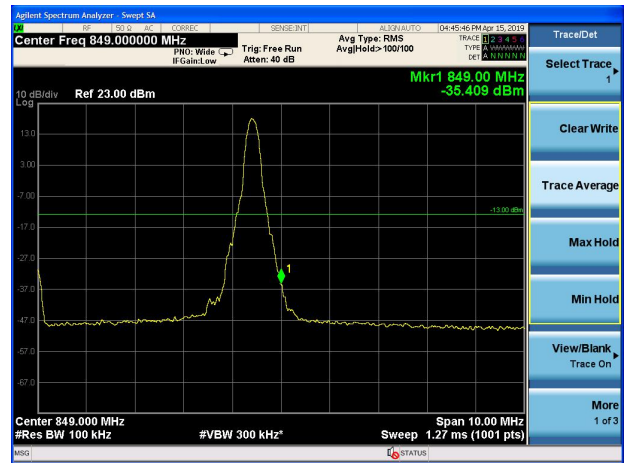

### LTE Band 5 16QAM 10MHz CH-Low 100%RB

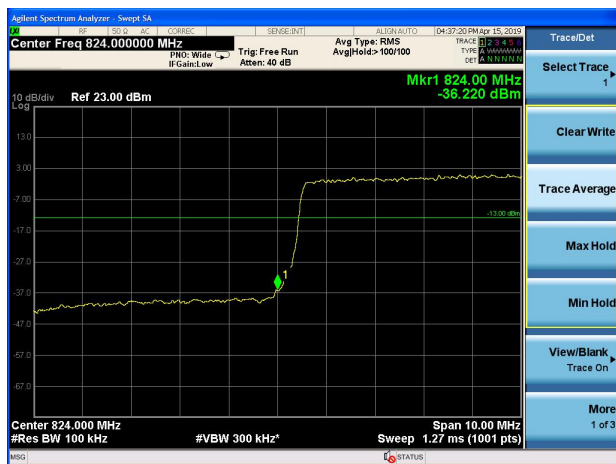

### LTE Band 5 16QAM 10MHz CH-High 100%RB

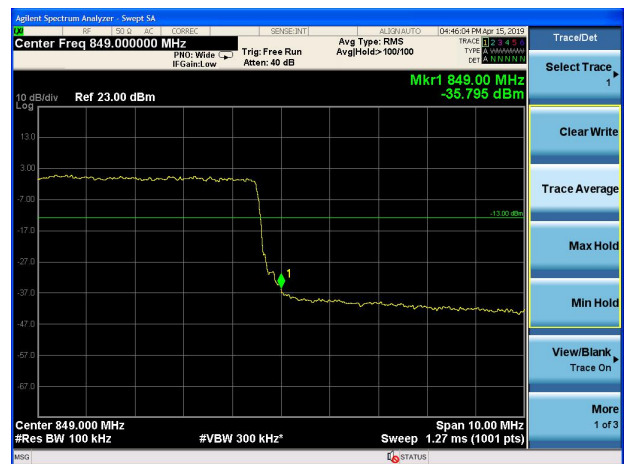

### 5.5. Peak-to-Average Power Ratio (PAPR)

#### Ambient condition

Temperature	Relative humidity	Pressure
23°C ~25°C	45%~50%	101.5kPa

#### Methods of Measurement

Measure the total peak power and record as  $P_{Pk}$ . And measure the total average power and record as  $P_{Avg}$ . Both the peak and average power levels must be expressed in the same logarithmic units (e.g., dBm). Determine the PAPR from:

$$PAPR (dB) = P_{Pk} (dBm) - P_{Avg} (dBm).$$

#### Test Setup

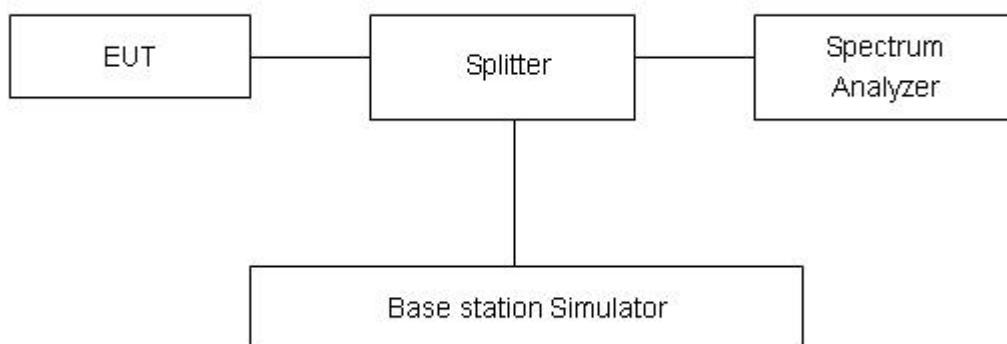

#### Limits

According to the Sec. 22.913(d), The peak-to-average ratio (PAR) of the transmission must not exceed 13 dB.

#### Measurement Uncertainty

The assessed measurement uncertainty to ensure 95% confidence level for the normal distribution is with the coverage factor  $k = 2$ ,  $U = 0.4$  dB.



## Test Results

Mode	Channel	Frequency (MHz)	Peak (dBm)	Avg (dBm)	PAPR (dB)	Limit (dB)	Conclusion
WCDMA Band V (RMC)	4132	826.4	25.14	21.78	3.36	≤13	PASS
	4183	836.6	24.96	21.72	3.24	≤13	PASS
	4233	846.6	27.97	21.65	6.32	≤13	PASS

LTE Band 5								
Modulation	Bandwidth (MHz)	Channel	Frequency (MHz)	Peak (dBm)	Avg (dBm)	PAPR (dB)	Limit (dB)	Conclusion
QPSK	1.4	20407	824.7	25.95	20.51	5.44	≤13	PASS
		20525	836.5	25.62	20.31	5.31	≤13	PASS
		20643	848.3	25.51	20.29	5.22	≤13	PASS
	3	20415	825.5	26.04	20.54	5.50	≤13	PASS
		20525	836.5	25.49	20.14	5.35	≤13	PASS
		20635	847.5	25.29	20.04	5.25	≤13	PASS
	5	20425	826.5	25.64	20.17	5.47	≤13	PASS
		20525	836.5	25.44	20.10	5.34	≤13	PASS
		20625	846.5	25.31	20.02	5.29	≤13	PASS
	10	20450	829	25.57	20.20	5.37	≤13	PASS
		20525	836.5	25.51	20.16	5.35	≤13	PASS
		20600	844	25.42	20.11	5.31	≤13	PASS
16QAM	1.4	20407	824.7	25.93	19.59	6.34	≤13	PASS
		20525	836.5	25.33	19.18	6.15	≤13	PASS
		20643	848.3	25.48	19.42	6.06	≤13	PASS
	3	20415	825.5	25.73	19.37	6.36	≤13	PASS
		20525	836.5	25.11	18.93	6.18	≤13	PASS
		20635	847.5	25.18	19.07	6.11	≤13	PASS
	5	20425	826.5	25.47	19.20	6.27	≤13	PASS
		20525	836.5	25.28	19.16	6.12	≤13	PASS
		20625	846.5	24.99	18.91	6.08	≤13	PASS
	10	20450	829	25.26	19.09	6.17	≤13	PASS
		20525	836.5	25.24	19.10	6.14	≤13	PASS
		20600	844	25.30	19.15	6.15	≤13	PASS

## 5.6. Frequency Stability

### Ambient condition

Temperature	Relative humidity	Pressure
23°C ~25°C	45%~50%	101.5kPa

### Method of Measurement

#### Frequency Stability (Temperature Variation)

The temperature inside the climate chamber is varied from -30°C to +55°C in 10°C step size,

(1) With all power removed, the temperature was decreased to 0°C and permitted to stabilize for three hours.

(2) Measure the carrier frequency with the test equipment in a “call mode”. These measurements should be made within 1 minute of powering up the mobile station, to prevent significant self warming.

(3) Repeat the above measurements at 10°C increments from -30°C to +55°C. Allow at least 1.5 hours at each temperature, un-powered, before making measurements. Frequency Stability (Voltage Variation)

The frequency stability shall be measured with variation of primary supply voltage as follows:

(1) Vary primary supply voltage from 85 to 115 percent of the nominal value for other than hand carried battery equipment.

(2) For hand carried, battery powered equipment, reduce primary supply voltage to the battery-operating end point which shall be specified by the manufacturer.

This transceiver is specified to operate with an input voltage of between 3.3 V and 4.2 V, with a nominal voltage of 3.8V.

### Test setup

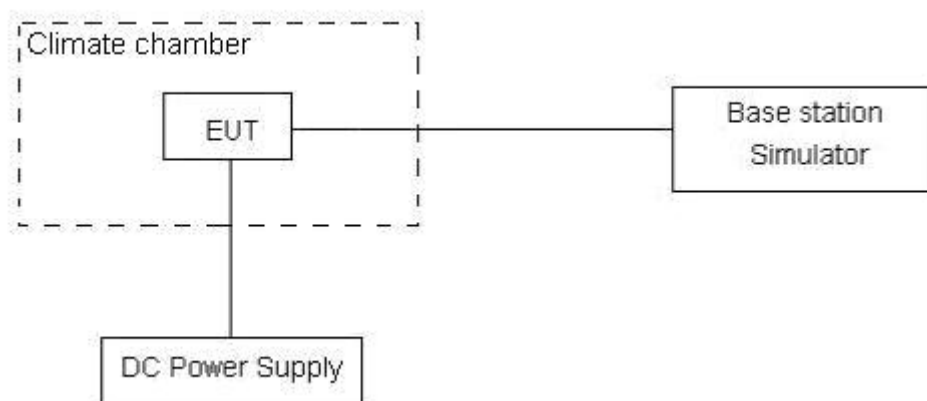





**Limits**

According to the Sec. 22.355, the frequency stability of the carrier shall be accurate to within 2.5 ppm of the received frequency for mobile stations.

Limits	$\leq 2.5$ ppm
--------	----------------

**Measurement Uncertainty**

The assessed measurement uncertainty to ensure 99.75% confidence level for the normal distribution is with the coverage factor  $k = 3$ ,  $U = 0.01$ ppm.

**Test Result**

WCDMA Band 5						
Condition		Freq.Error (Hz)	Freq.Error (Hz)	Frequency Stability (ppm)	Frequency Stability (ppm)	Verdict
Temperature	Voltage	QPSK	BPSK	QPSK	BPSK	
Normal (25°C)	Normal	4.09	3.49	0.00217	0.00185	PASS
Extreme (55°C)		14.92	10.15	0.00794	0.00540	PASS
Extreme (50°C)		13.45	15.81	0.00716	0.00841	PASS
Extreme (40°C)		15.69	5.18	0.00835	0.00275	PASS
Extreme (30°C)		12.46	13.13	0.00663	0.00698	PASS
Extreme (20°C)		12.20	6.25	0.00649	0.00332	PASS
Extreme (10°C)		9.66	15.95	0.00514	0.00849	PASS
Extreme (0°C)		8.92	9.35	0.00474	0.00497	PASS
Extreme (-10°C)		2.04	13.59	0.00108	0.00723	PASS
Extreme (-20°C)		2.83	16.74	0.00151	0.00891	PASS
Extreme (-30°C)		2.96	16.83	0.00157	0.00895	PASS
25°C	LV	14.39	11.76	0.00765	0.00626	PASS
	HV	6.74	1.36	0.00358	0.00072	PASS

LTE Band 5, 10MHz BANDWIDTH						
Condition		Freq.Error (Hz)	Freq.Error (Hz)	Frequency Stability (ppm)	Frequency Stability (ppm)	Verdict
Temperature	Voltage	16QAM	QPSK	16QAM	QPSK	
Normal (25°C)	Normal	3.34	2.36	0.00178	0.00125	PASS
Extreme (55°C)		16.52	14.72	0.00879	0.00783	PASS
Extreme (50°C)		5.88	4.05	0.00313	0.00216	PASS
Extreme (40°C)		14.47	8.74	0.00769	0.00465	PASS
Extreme (30°C)		5.33	17.30	0.00283	0.00920	PASS
Extreme (20°C)		15.92	6.04	0.00847	0.00321	PASS
Extreme (10°C)		2.34	17.10	0.00125	0.00910	PASS
Extreme (0°C)		16.29	8.78	0.00866	0.00467	PASS
Extreme (-10°C)		1.75	13.18	0.00093	0.00701	PASS
Extreme (-20°C)		6.08	7.31	0.00323	0.00389	PASS
Extreme (-30°C)		12.73	3.05	0.00677	0.00162	PASS
25°C	LV	5.17	13.04	0.00275	0.00694	PASS
	HV	10.28	17.62	0.00547	0.00937	PASS

### 5.7. Spurious Emissions at Antenna Terminals

#### Ambient condition

Temperature	Relative humidity	Pressure
23°C ~25°C	45%~50%	101.5kPa

#### Method of Measurement

The EUT was connected to Spectrum Analyzer and Base Station Simulator via power Splitter. The measurement is carried out using a spectrum analyzer. The spectrum analyzer scans from 9kHz to the 10th harmonic of the carrier.

The peak detector is used. RBW are set to 100 kHz and VBW are set to 300 kHz for below 1G, RBW are set to 1MHz and VBW are set to 3MHz for above 1G, Sweep is set to ATUO.

The modulation mode and RB allocation refer to section 5.1, using the maximum output power configuration.

#### Test setup

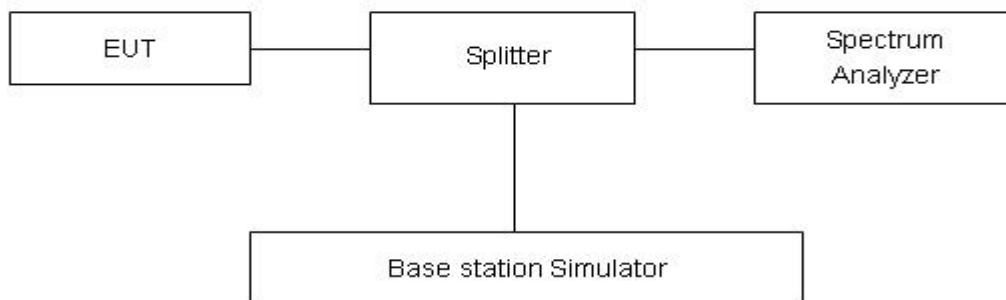

#### Limits

Rule Part 22.917(a) specifies that “The power of any emission outside of the authorized operating frequency ranges must be attenuated below the transmitting power (P) by a factor of at least 43 + 10 log (P) dB.”

Limit	-13 dBm
-------	---------

#### Measurement Uncertainty

The assessed measurement uncertainty to ensure 99.75% confidence level for the normal distribution is with the coverage factor  $k = 1.96$ .

Frequency	Uncertainty
9kHz-1GHz	0.684 dB
1GHz-18GHz	1.407 dB

**Test Result**

Sweep the whole frequency band through the range from 9kHz to the 10th harmonic of the carrier, the emissions more than 20 dB below the limit are not reported.

The signal beyond the limit is carrier.

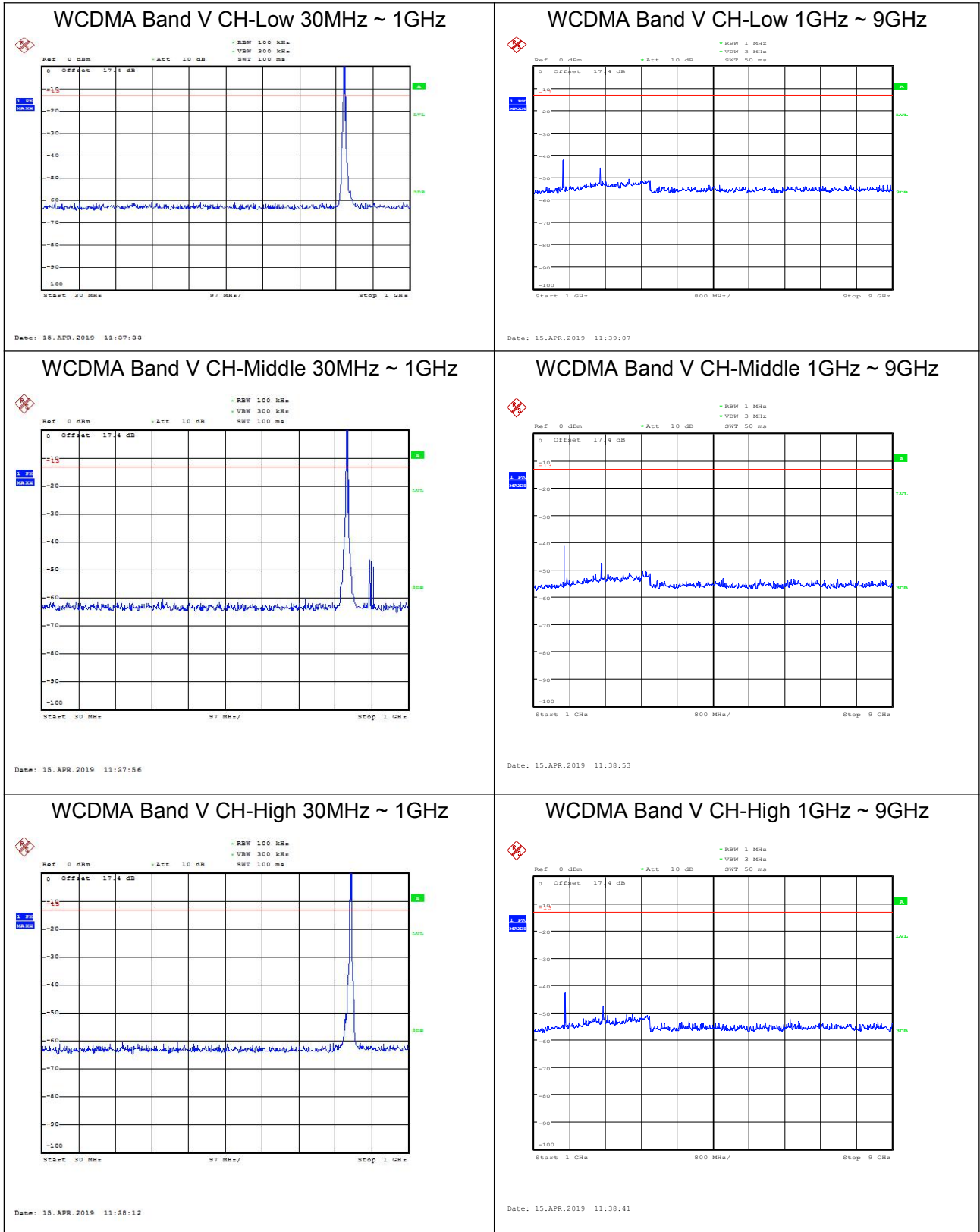



### LTE Band 5 1.4MHz CH-Low 30MHz~1GHz

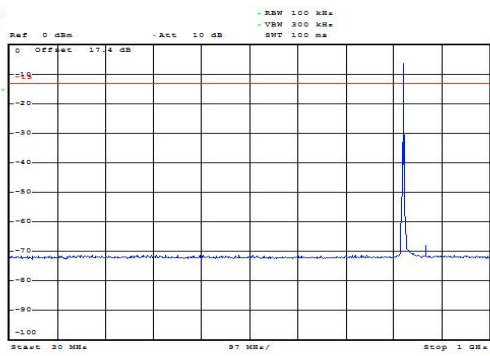

Date: 15.APR.2019 14:42:29

### LTE Band 5 1.4MHz CH-Low 1GHz~9GHz

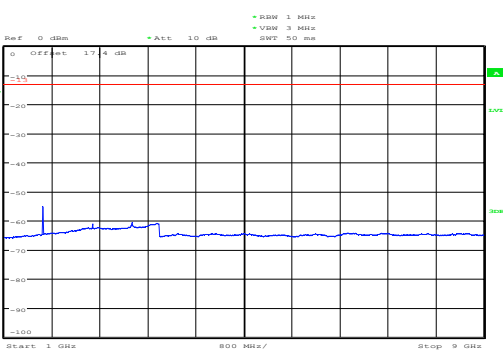

Date: 15.APR.2019 14:50:39

### LTE Band 5 1.4MHz CH-Middle 30MHz~1GHz

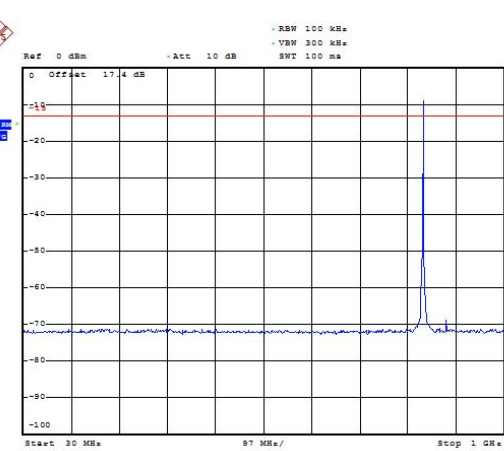

Date: 15.APR.2019 14:42:45

### LTE Band 5 1.4MHz CH-Middle 1GHz~9GHz

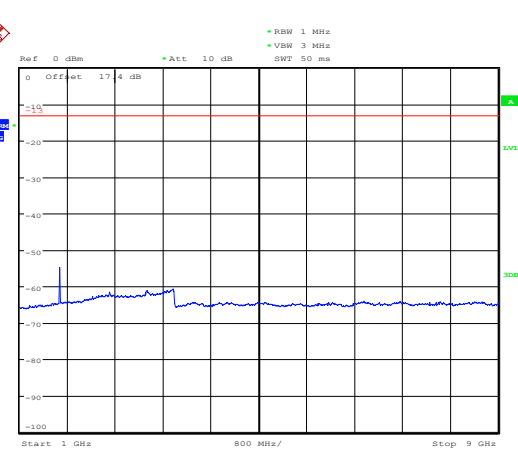

Date: 15.APR.2019 14:50:49

### LTE Band 5 1.4MHz CH-High 30MHz~1GHz

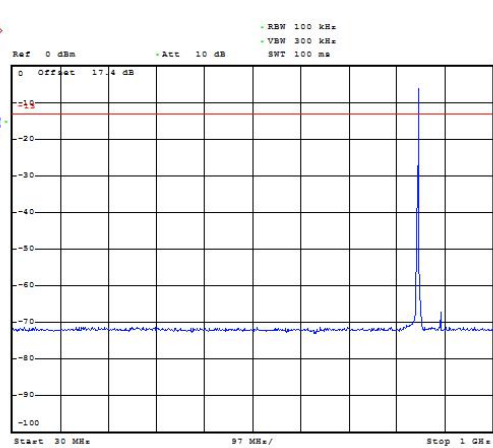

Date: 15.APR.2019 14:40:03

### LTE Band 5 1.4MHz CH-High 1GHz~9GHz

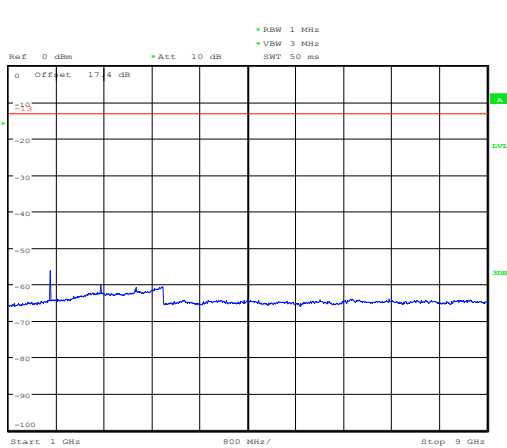

Date: 15.APR.2019 14:51:01



### LTE Band 5 3MHz CH-Low 30MHz~1GHz

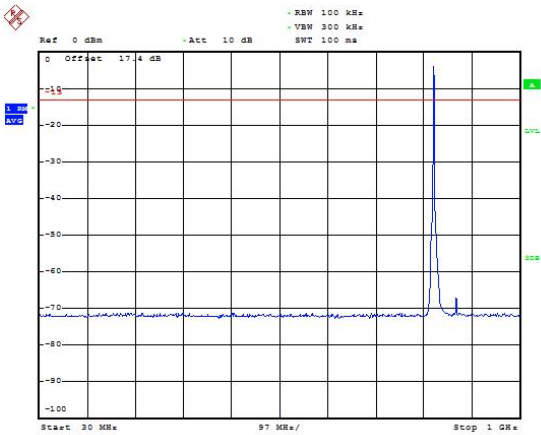

Date: 15.APR.2019 14:42:28

### LTE Band 5 3MHz CH-Low 1GHz~9GHz

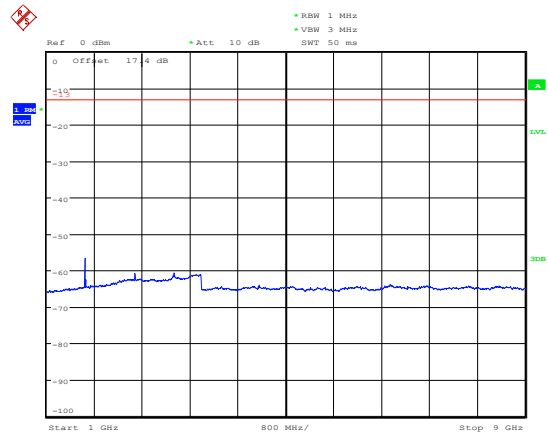

Date: 15.APR.2019 14:51:19

### LTE Band 5 3MHz CH-Middle 30MHz~1GHz

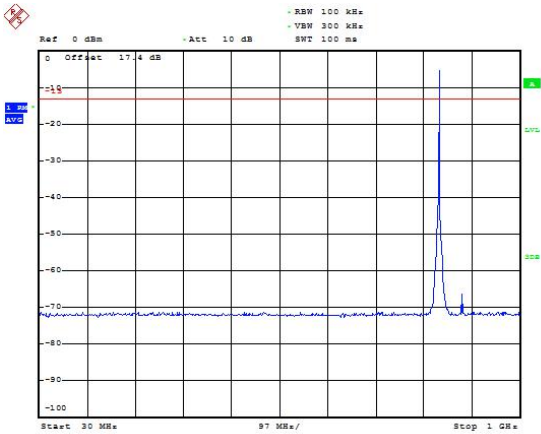

Date: 15.APR.2019 14:42:40

### LTE Band 5 3MHz CH-Middle 1GHz~9GHz

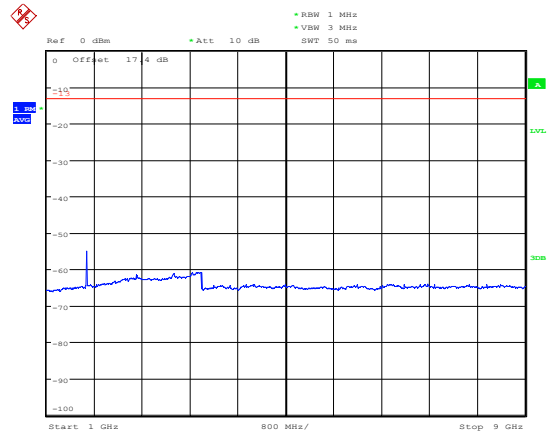

Date: 15.APR.2019 14:52:16

### LTE Band 5 3MHz CH-High 30MHz~1GHz

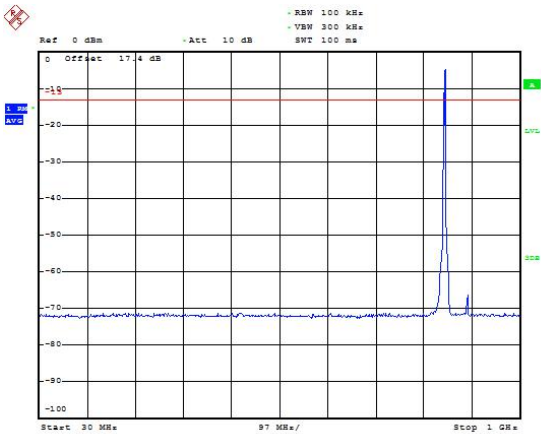

Date: 15.APR.2019 14:42:52

### LTE Band 5 3MHz CH-High 1GHz~9GHz

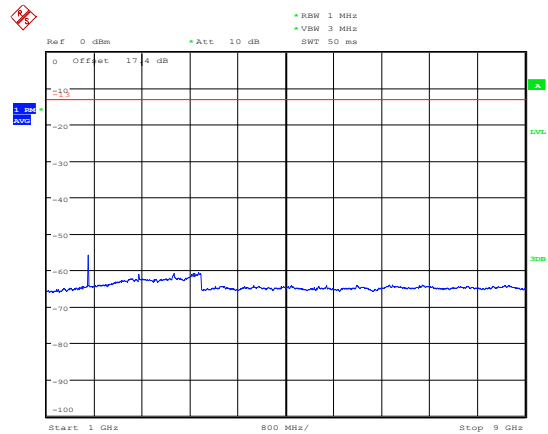

Date: 15.APR.2019 14:52:26



### LTE Band 5 5MHz CH-Low 30MHz~1GHz

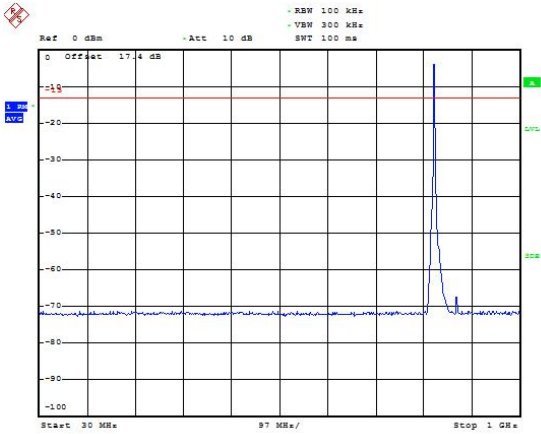

Date: 15.APR.2019 14:44:19

### LTE Band 5 5MHz CH-Low 1GHz~9GHz

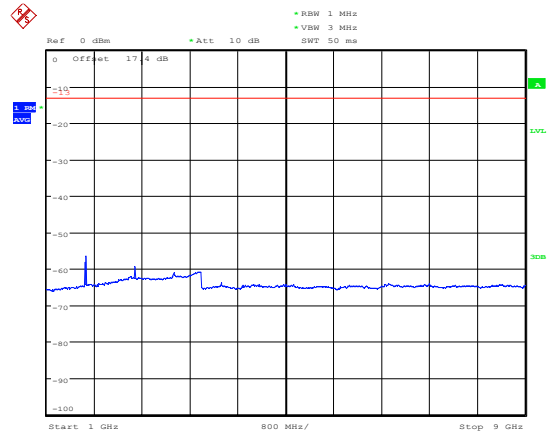

Date: 15.APR.2019 14:52:46

### LTE Band 5 5MHz CH-Middle 30MHz~1GHz

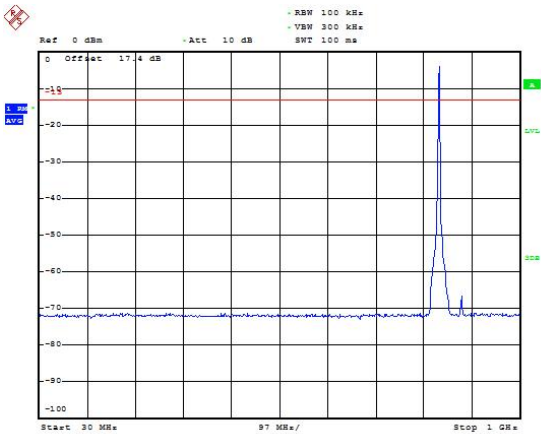

Date: 15.APR.2019 14:44:26

### LTE Band 5 5MHz CH-Middle 1GHz~9GHz

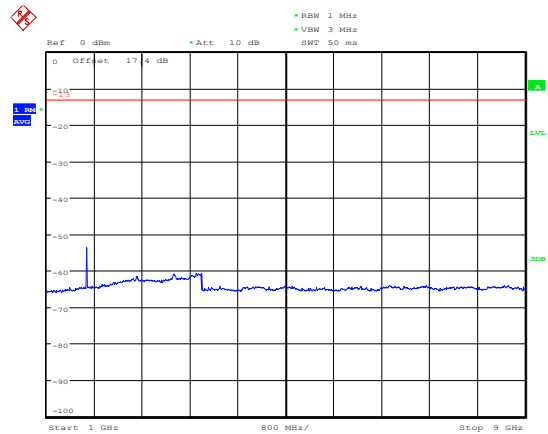

Date: 15.APR.2019 14:52:55

### LTE Band 5 5MHz CH-High 30MHz~1GHz

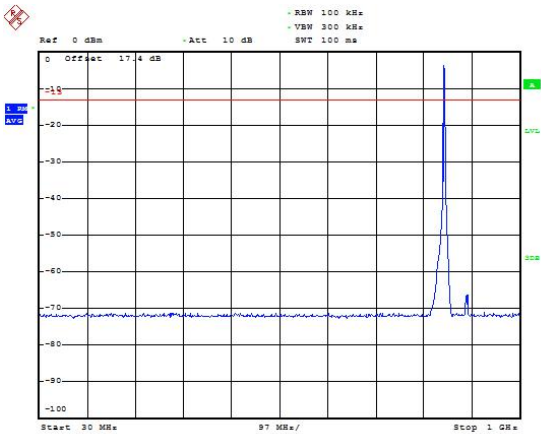

Date: 15.APR.2019 14:44:38

### LTE Band 5 5MHz CH-High 1GHz~9GHz

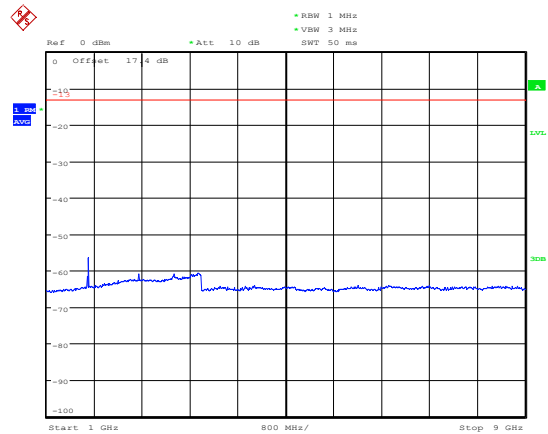

Date: 15.APR.2019 14:53:05



### LTE Band 5 10MHz CH-Low 30MHz~1GHz

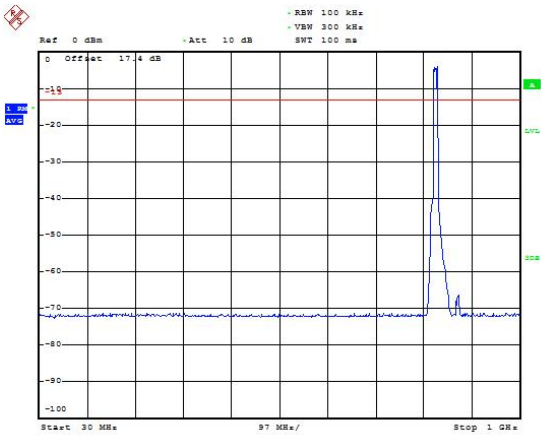

Date: 15.APR.2019 14:44:56

### LTE Band 5 10MHz CH-Low 1GHz~9GHz

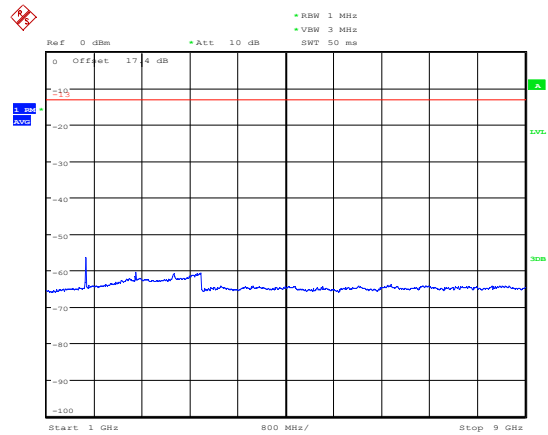

Date: 15.APR.2019 14:46:36

### LTE Band 5 10MHz CH-Middle 30MHz~1GHz

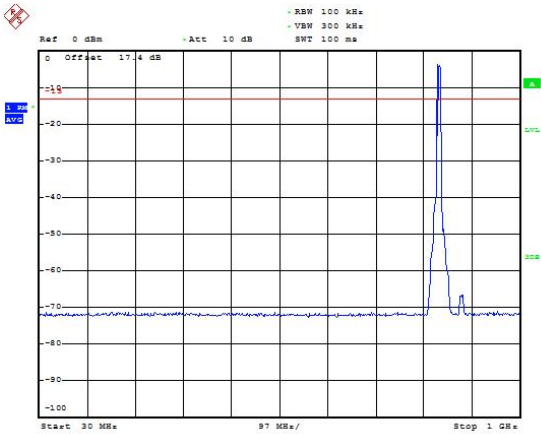

Date: 15.APR.2019 14:45:08

### LTE Band 5 10MHz CH-Middle 1GHz~9GHz

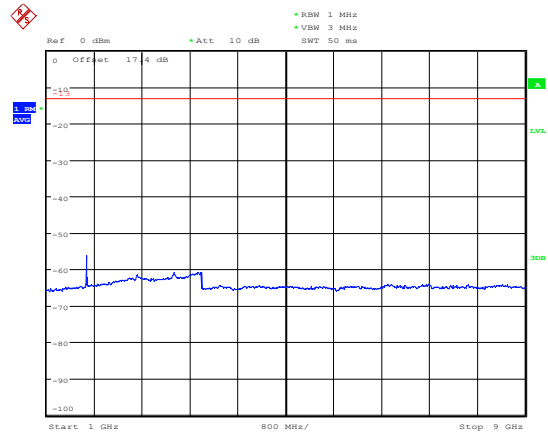

Date: 15.APR.2019 14:46:27

### LTE Band 5 10MHz CH-High 30MHz~1GHz

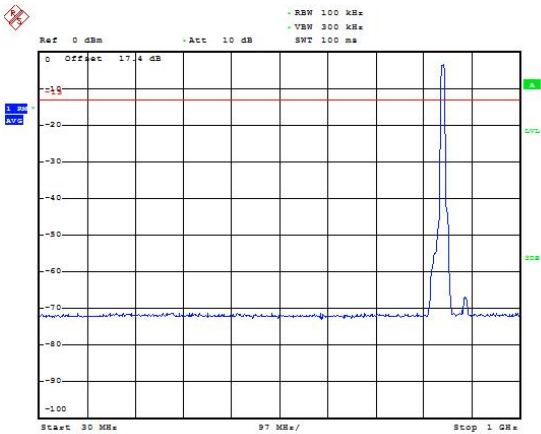

Date: 15.APR.2019 14:45:20

### LTE Band 5 10MHz CH-High 1GHz~9GHz

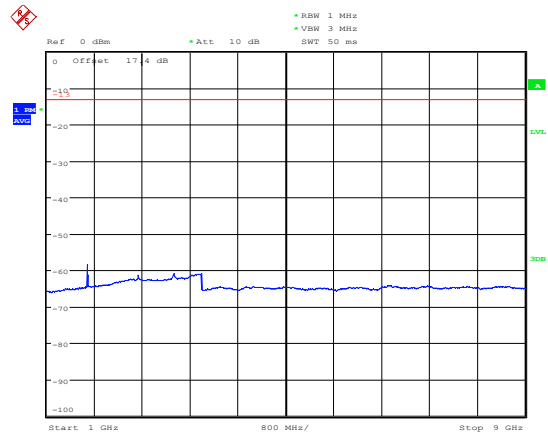

Date: 15.APR.2019 14:46:17



## 5.8. Radiates Spurious Emission

### Ambient condition

Temperature	Relative humidity	Pressure
23°C ~25°C	45%~50%	101.5kPa

### Method of Measurement

1. The testing follows FCC KDB 971168 v03r01 Section 5.8 and ANSI C63.26 (2015).
2. Below 1GHz: The EUT is placed on a turntable 0.8 meters above the ground in the chamber, 3 meter away from the antenna. The maximal emission value is acquired by adjusting the antenna height, polarisation and turntable azimuth. Normally, the height range of antenna is 1 m to 4 m, the azimuth range of turntable is 0° to 360°, and the receive antenna has two polarizations Vertical (V) and Horizontal (H). Above 1GHz: (Note: the FCC's permission to use 1.5m as an alternative per TCBC Conf call of Dec. 2, 2014.) The EUT is placed on a turntable 1.5 meters above the ground in the chamber, 3 meter away from the antenna. The maximal emission value is acquired by adjusting the antenna height, polarisation and turntable azimuth. Normally, the height range of antenna is 1 m to 4 m, the azimuth range of turntable is 0° to 360°, and the receive antenna has two polarizations Vertical (V) and Horizontal (H).
3. A loop antenna, A log-periodic antenna or horn antenna shall be substituted in place of the EUT. The log-periodic antenna will be driven by a signal generator and the level will be adjusted till the same power value on the spectrum analyzer or receiver. The level of the spurious emissions can be calculated through the level of the signal generator, cable loss, the gain of the substitution antenna and the reading of the spectrum analyzer or receiver.
4. The EUT is then put into continuously transmitting mode at its maximum power level during the test. Set Test Receiver or Spectrum RBW=200Hz,VBW=600Hz for 9kHz150kHz , RBW=10kHz, VBW=30kHz 150kHz-30MHz , RBW=100kHz,VBW=300kHz for 30MHz to 1GHz and RBW=1MHz, VBW=3MHz for above 1GHz, And the maximum value of the receiver should be recorded as (Pr).
5. The EUT shall be replaced by a substitution antenna. In the chamber, an substitution antenna for the frequency band of interest is placed at the reference point of the chamber. An RF Signal source for the frequency band of interest is connected to the substitution antenna with a cable that has been constructed to not interfere with the radiation pattern of the antenna. A power (PMea) is applied to the input of the substitution antenna, and adjust the level of the signal generator output until the value of the receiver reach the previously recorded (Pr). The power of signal source (PMea) is recorded. The test should be performed by rotating the test item and adjusting the receiving antenna polarization.
6. A amplifier should be connected to the Signal Source output port. And the cable should be connect between the Amplifier and the Substitution Antenna. The cable loss (Pcl) ,the Substitution Antenna Gain (Ga) and the Amplifier Gain (PAg) should be recorded after test.
7. The measurement results are obtained as described below:  
Power(EIRP)=PMea- PAg - Pcl + Ga  
The measurement results are amend as described below:  
Power(EIRP)=PMea- Pcl + Ga
8. This value is EIRP since the measurement is calibrated using an antenna of known gain (2.15 dBi)

and known input power. ERP can be calculated from EIRP by subtracting the gain of the dipole,  $ERP = EIRP - 2.15\text{dBi}$ .

The modulation mode and RB allocation refer to section 5.1, using the maximum output power configuration.

**Test setup**

**9KHz ~ 30MHz**

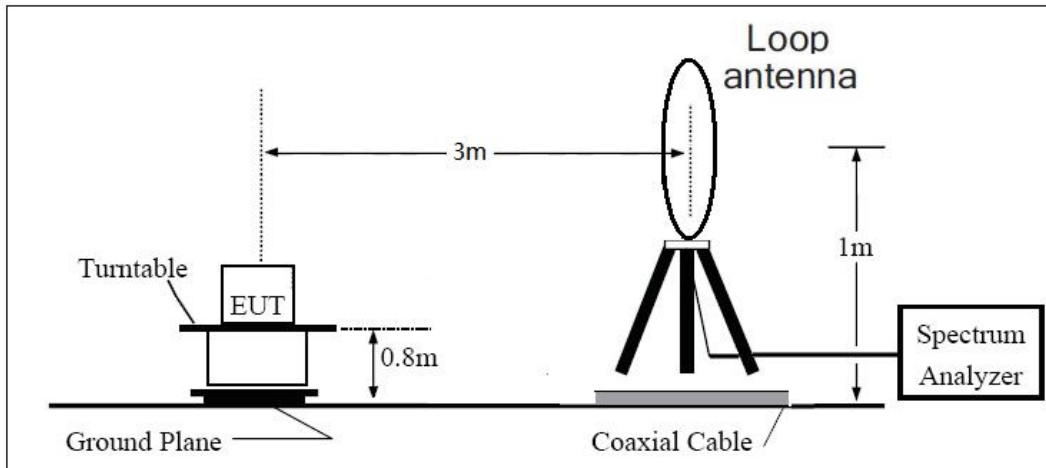

**30MHz ~ 1GHz**

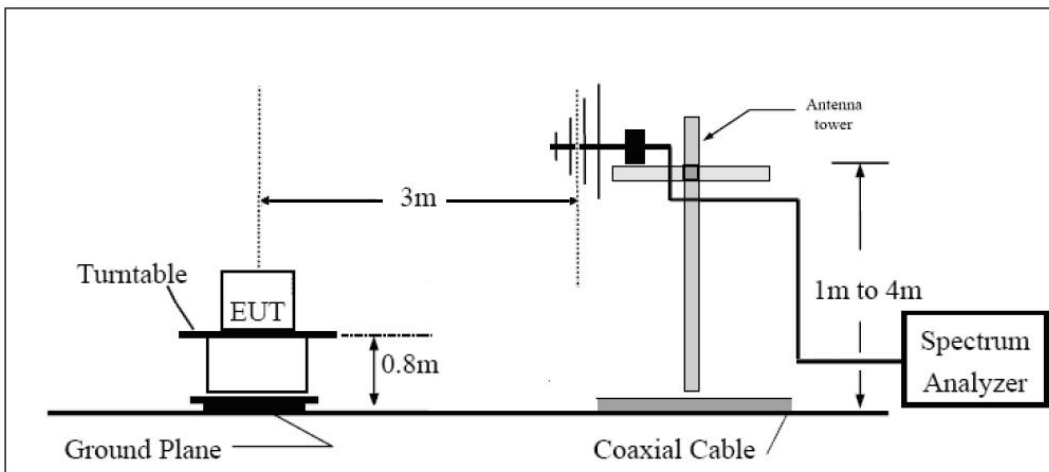

**Above 1GHz**

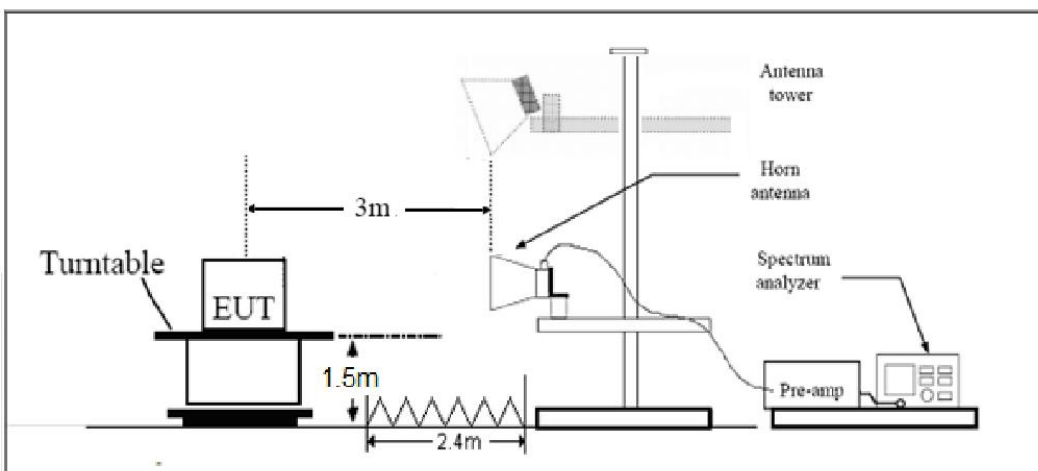



Note: Area side:2.4mX3.6m

**Limits**

Rule Part 22.917(a) specifies that “The power of any emission outside of the authorized operating frequency ranges must be attenuated below the transmitting power (P) by a factor of at least  $43 + 10 \log (P)$  dB.”

Limit	-13 dBm
-------	---------

**Measurement Uncertainty**

The assessed measurement uncertainty to ensure 95% confidence level for the normal distribution is with the coverage factor  $k = 1.96$ ,  $U = 3.55$  dB.

**Test Result**

Sweep the whole frequency band through the range from 9kHz to the 10th harmonic of the carrier, the emissions below the noise floor will not be recorded in the report.

WCDMA Band V CH-Low

Harmonic	Frequency (MHz)	SG (dBm)	Cable Loss (dB)	Gain (dBi)	Antenna Polarization	ERP Level (dBm)	Limit (dBm)	Margin (dB)	Azimuth (deg)
2	1652.8	-58.30	2.00	10.15	Horizontal	-52.30	-13.00	39.30	0
3	2479.2	-58.62	2.51	11.35	Horizontal	-51.93	-13.00	38.93	90
4	3305.6	-63.36	4.20	10.85	Horizontal	-58.86	-13.00	45.86	45
5	4132.0	-59.10	5.20	11.35	Horizontal	-55.10	-13.00	42.10	315
6	4958.4	-59.43	5.50	11.95	Horizontal	-55.13	-13.00	42.13	225
7	5784.8	-60.20	5.70	13.55	Horizontal	-54.50	-13.00	41.50	90
8	6611.2	-57.62	6.30	13.75	Horizontal	-52.32	-13.00	39.32	0
9	7437.6	-54.11	6.80	13.85	Horizontal	-49.21	-13.00	36.21	135
10	8264.0	-54.38	6.90	14.25	Horizontal	-49.18	-13.00	36.18	315

Note: 1.The other Spurious RF Radiated emissions level is no more than noise floor.  
 2.The worst emission was found in the antenna is Horizontal position.

WCDMA Band V CH-Middle

Harmonic	Frequency (MHz)	SG (dBm)	Cable Loss (dB)	Gain (dBi)	Antenna Polarization	ERP Level (dBm)	Limit (dBm)	Margin (dB)	Azimuth (deg)
2	1674.9	-59.26	2.00	10.75	Horizontal	-52.66	-13.00	39.66	45
3	2509.8	-58.81	2.51	11.05	Horizontal	-52.42	-13.00	39.42	315
4	3346.4	-64.10	4.20	11.15	Horizontal	-59.30	-13.00	46.30	225
5	4183.0	-60.13	5.20	11.15	Horizontal	-56.33	-13.00	43.33	180
6	5019.6	-58.39	5.50	11.95	Horizontal	-54.09	-13.00	41.09	270
7	5856.2	-59.91	5.70	13.55	Horizontal	-54.21	-13.00	41.21	45
8	6692.8	-56.76	6.30	13.75	Horizontal	-51.46	-13.00	38.46	315
9	7529.4	-55.25	6.80	13.85	Horizontal	-50.35	-13.00	37.35	225
10	8366.0	-55.72	6.90	14.25	Horizontal	-50.52	-13.00	37.52	315

Note: 1.The other Spurious RF Radiated emissions level is no more than noise floor.  
 2.The worst emission was found in the antenna is Horizontal position.



## WCDMA Band V CH-High

Harmonic	Frequency (MHz)	SG (dBm)	Cable Loss (dB)	Gain (dBi)	Antenna Polarization	ERP Level (dBm)	Limit (dBm)	Margin (dB)	Azimuth (deg)
2	1693.2	-60.61	2.00	10.15	Horizontal	-54.61	-13.00	41.61	225
3	2539.8	-60.23	2.51	11.05	Horizontal	-53.84	-13.00	40.84	270
4	3386.4	-63.94	4.20	11.15	Horizontal	-59.14	-13.00	46.14	135
5	4233.0	-60.36	5.20	11.15	Horizontal	-56.56	-13.00	43.56	90
6	5079.6	-57.75	5.50	11.95	Horizontal	-53.45	-13.00	40.45	270
7	5926.2	-59.27	5.70	13.55	Horizontal	-53.57	-13.00	40.57	135
8	6772.8	-56.98	6.30	13.75	Horizontal	-51.68	-13.00	38.68	45
9	7619.4	-54.98	6.80	13.85	Horizontal	-50.08	-13.00	37.08	45
10	8466.0	-54.67	6.90	14.25	Horizontal	-49.47	-13.00	36.47	0

Note: 1.The other Spurious RF Radiated emissions level is no more than noise floor.

2.The worst emission was found in the antenna is Horizontal position.

## LTE Band 5 10MHz CH-Low

Harmonic	Frequency (MHz)	SG (dBm)	Cable Loss (dB)	Gain (dBi)	Antenna Polarization	ERP Level (dBm)	Limit (dBm)	Margin (dB)	Azimuth (deg)
2	1652.8	-54.96	2.00	10.75	Horizontal	-48.36	-13.00	35.36	90
3	2479.2	-53.27	2.51	11.05	Horizontal	-46.88	-13.00	33.88	135
4	3303.8	-64.08	4.20	11.15	Horizontal	-59.28	-13.00	46.28	90
5	4126.5	-60.64	5.20	11.15	Horizontal	-56.84	-13.00	43.84	315
6	4947.8	-60.03	5.50	11.95	Horizontal	-55.73	-13.00	42.73	225
7	5779.9	-60.42	5.70	13.55	Horizontal	-54.72	-13.00	41.72	45
8	6603.0	-56.98	6.30	13.75	Horizontal	-51.68	-13.00	38.68	0
9	7426.1	-54.41	6.80	13.85	Horizontal	-49.51	-13.00	36.51	270
10	8251.9	-53.85	6.90	14.25	Horizontal	-48.65	-13.00	35.65	0

Note: 1.The other Spurious RF Radiated emissions level is no more than noise floor.

2.The worst emission was found in the antenna is Horizontal position.



## LTE Band 5 10MHz CH-Middle

Harmonic	Frequency (MHz)	SG (dBm)	Cable Loss (dB)	Gain (dBi)	Antenna Polarization	ERP Level (dBm)	Limit (dBm)	Margin (dB)	Azimuth (deg)
2	1664.1	-51.63	2.00	10.75	Horizontal	-45.03	-13.00	32.03	315
3	2496.2	-53.76	2.51	11.05	Horizontal	-47.37	-13.00	34.37	135
4	3397.9	-63.98	4.20	11.15	Horizontal	-59.18	-13.00	46.18	45
5	4160.6	-60.93	5.20	11.15	Horizontal	-57.13	-13.00	44.13	0
6	4993.9	-59.05	5.50	11.95	Horizontal	-54.75	-13.00	41.75	90
7	5826.4	-60.04	5.70	13.55	Horizontal	-54.34	-13.00	41.34	225
8	6658.9	-56.19	6.30	13.75	Horizontal	-50.89	-13.00	37.89	315
9	7492.5	-54.75	6.80	13.85	Horizontal	-49.85	-13.00	36.85	270
10	8316.0	-54.25	6.90	14.25	Horizontal	-49.05	-13.00	36.05	45

Note: 1.The other Spurious RF Radiated emissions level is no more than noise floor.

2.The worst emission was found in the antenna is Horizontal position.

## LTE Band 5 10MHz CH-High

Harmonic	Frequency (MHz)	SG (dBm)	Cable Loss (dB)	Gain (dBi)	Antenna Polarization	ERP Level (dBm)	Limit (dBm)	Margin (dB)	Azimuth (deg)
2	1693.2	-53.22	2.00	10.75	Horizontal	-46.62	-13.00	33.62	135
3	2539.8	-57.84	2.51	11.05	Horizontal	-51.45	-13.00	38.45	225
4	3358.9	-64.58	4.20	11.15	Horizontal	-59.78	-13.00	46.78	0
5	4201.1	-60.37	5.20	11.15	Horizontal	-56.57	-13.00	43.57	45
6	5046.8	-58.00	5.50	11.95	Horizontal	-53.70	-13.00	40.70	90
7	5884.1	-59.89	5.70	13.55	Horizontal	-54.19	-13.00	41.19	180
8	6693.4	-56.93	6.30	13.75	Horizontal	-51.63	-13.00	38.63	225
9	7573.1	-56.09	6.80	13.85	Horizontal	-51.19	-13.00	38.19	315
10	8397.0	-54.56	6.90	14.25	Horizontal	-49.36	-13.00	36.36	270

Note: 1.The other Spurious RF Radiated emissions level is no more than noise floor.

2.The worst emission was found in the antenna is Horizontal position.



## 6. Main Test Instruments

Name	Manufacturer	Type	Serial Number	Calibration Date	Expiration Date
Base Station Simulator	R&S	CMW500	113824	2018-05-20	2019-05-19
Power Splitter	Hua Xiang	SHX-GF2-2-13	10120101	/	/
Spectrum Analyzer	Key sight	N9010A	MY50210259	2018-05-20	2019-05-19
Universal Radio Communication Tester	Key sight	E5515C	MY48367192	2018-05-20	2019-05-19
Signal Analyzer	R&S	FSV30	100815	2018-12-16	2019-12-15
Loop Antenna	SCHWARZBECK	FMZB1519	1519-047	2017-09-26	2019-09-25
Trilog Antenna	SCHWARZBECK	VUBL 9163	9163-201	2017-11-18	2019-11-17
Horn Antenna	R&S	HF907	100126	2018-07-07	2020-07-06
Horn Antenna	ETS-Lindgren	3160-09	00102643	2018-06-20	2020-06-19
Signal generator	R&S	SMB 100A	102594	2018-05-20	2019-05-19
Climatic Chamber	ESPEC	SU-242	93000506	2017-12-17	2020-12-16
Preamplifier	R&S	SCU18	102327	2018-05-20	2019-05-19
MOB COMMS DC SUPPLY	Keysight	66319D	MY43004105	2018-05-21	2019-05-20
RF Cable	Agilent	SMA 15cm	0001	2019-03-15	2019-06-14
Software	R&S	EMC32	9.26.0	/	/

\*\*\*\*\*END OF REPORT \*\*\*\*\*

## ANNEX A: EUT Appearance and Test Setup

### A.1 EUT Appearance



a: EUT

Picture 1 EUT and Accessory



## A.2 Test Setup

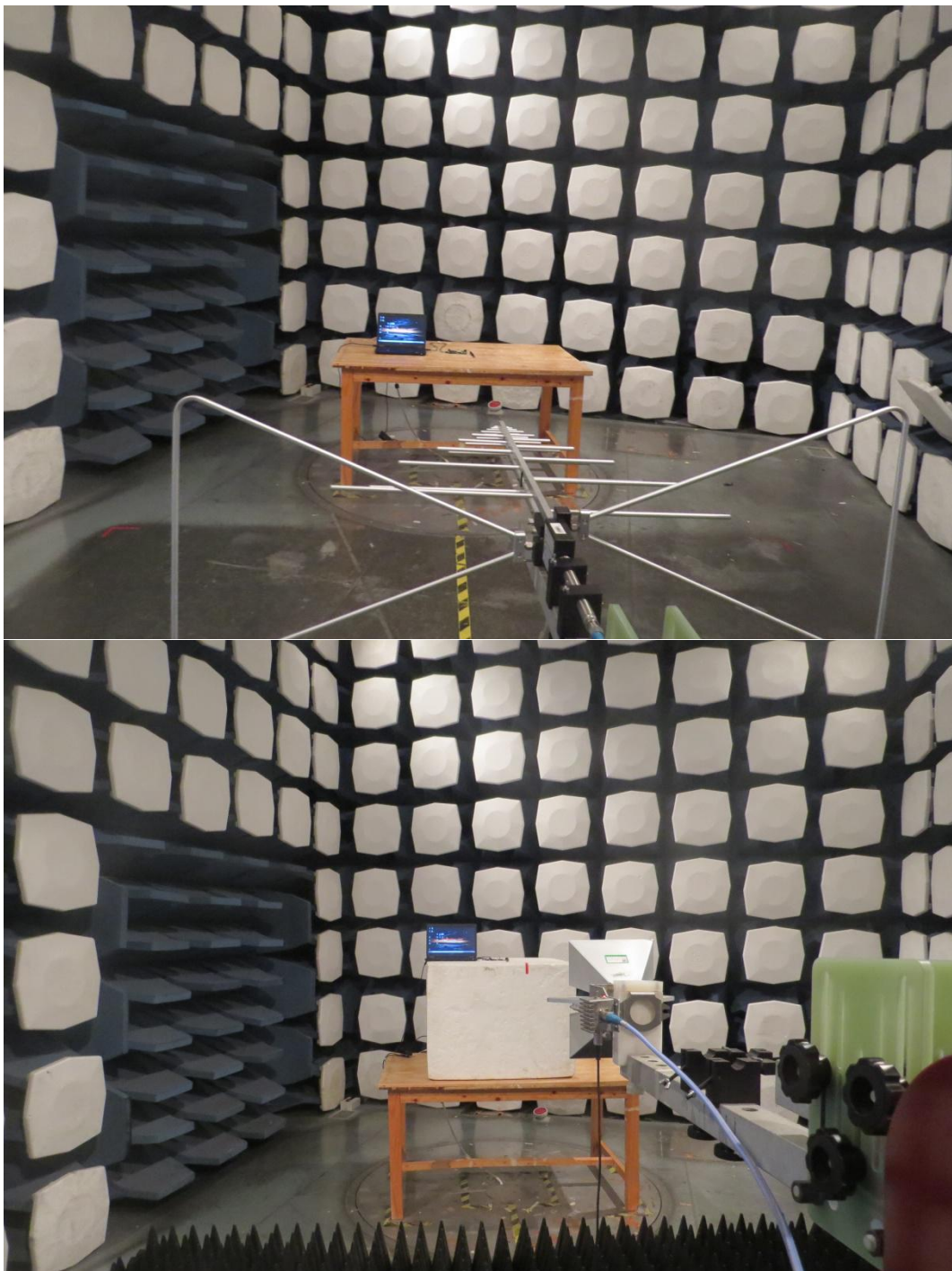

Picture 2 Radiated Spurious Emissions Test setup