

U9507A User Manual

Contents

1. Introduction	3
1.1 Overview	3
1.2 Application scenario	3
2. U9507A interfaces	4
2.1 U9507A interface summary	4
2.1.1 Test points	5
2.1.2 Mini PCIe Interface	5
2.1.3 RF interface	8
2.2 U9507A interface application	9
2.2.1 RF antenna interface	9
2.2.2 RF Line Routing Design	10
2.2.3 Power supply and earth	13
2.2.4 USB interface	14
2.2.5 USIM interface	16
2.2.6 Audio interface*	17
2.2.7 PCM interface*	19
2.2.8 UART interface*	20
2.2.9 LED control	21
2.2.10 Others*	22
3. U9507A key features	23
3.1 Internet access	23
3.2 SMS	23
3.3 GPS	24
3.4 Phonebook	24
4. Application Illustration	24
4.1 Dial-up procedure	24
4.2 SMS	25
4.2.1 Message Format	25
4.2.2 Set Message Storage Location	25
4.2.3 PDU Format	26
4.2.4 TEXT Format	28
4.2.5 SMS Service Center Address Setting	29
4.3 PHONE BOOK	30
4.3.1 Set Phone Book Storage Location	30
4.3.2 Read Phonebook entries	30
4.3.3 Write phonebook entry	30
4.3.4 Find phonebook entries	31
4.4 AUDIO	31
4.4.1 Originate Call	31
4.4.2 Answer a incoming call	31
4.4.3 Disconnect call	31
5. Safety information	31
6. FCC Caution	32
Appendix: Mechanical dimensions of U9507A	32

1. Introduction

1.1 Overview

The LONGSUNG U9507A LTE wireless module, powered by Qualcomm MDM9207 chipset, can be integrated into any devices for 4G mobile applications. It provides phone book, SMS、 audio and GPS, as well as high speed internet access to LTE,HSUPA,HSDPA, UMTS and GSM networks worldwide.

The U9507A module complies with the technical standard listed below:

LTE

FDD: 150Mbps(DL), 50Mbps(UL)

Support Release 10 category 4

HSPA+

HSPA+: 42.2Mbps(DL), 5.76Mbps(UL)

EDGE

3GPP R4, Class 12, up to 236.8 Kbps DL and 118.4Kbps UL

Mobile station class B

GPRS

3GPP R4, Class 10, Up to 85.6 Kbps DL and 42.8 Kbps UL

The frequency bands supported:

	U9507A
LTE-FDD	2/4/5/12/13/17/28
UMTS	2/4/5
GSM	2/5

“-” : not support

It working at environment temperature: -40℃~+85℃。

1.2 Application scenario

The LTE U9507A wireless module support phone book, SMS, audio, GPS and Internet access functions. The application of U9507A is as follows:

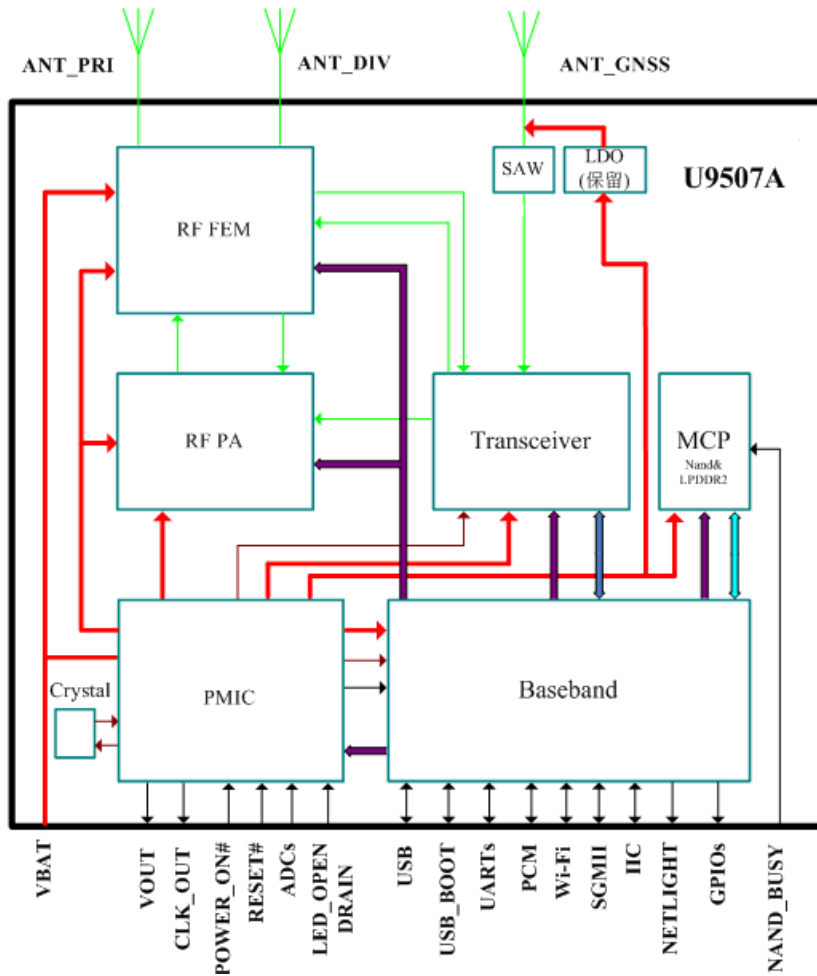

Figure1-1 U9507A application scenario

2. U9507A interfaces

2.1 U9507A interface summary

The LTE wireless module U9507A supports for multimode operation: LTE,HSUPA,HSDPA, UMTS and GSM. The size of U9507A is 50.85×29.9×4.6mm. And the appearance is shown in Figure 2-1 and Figure 2-2.



Figure 2-1 The front view of U9507A

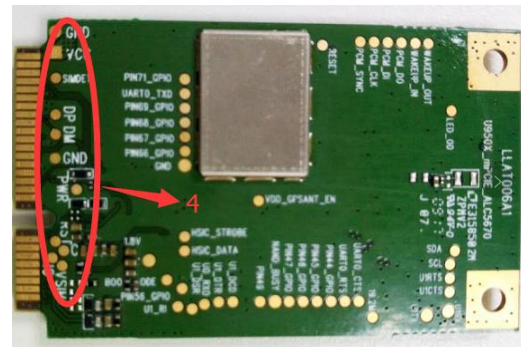

Figure 2-2 The rear view of U9507A

The antenna pads are show as part 1 in the Figure 2-1, the below one is for the main antenna, and the upper one is for the diversity antenna; The antenna pad which is shown as part 2 in Figure 2-1 is for GPS application; A miniPCIe interface is shown as part 3 in Figure 2-1; U9507A module also offers some test points, they are shown as part 4 in Figure 2-2

2.1.1 Test points

The test points of U9507A are displayed in figure 2-3, and the definition of each point is listed in table 2.1.

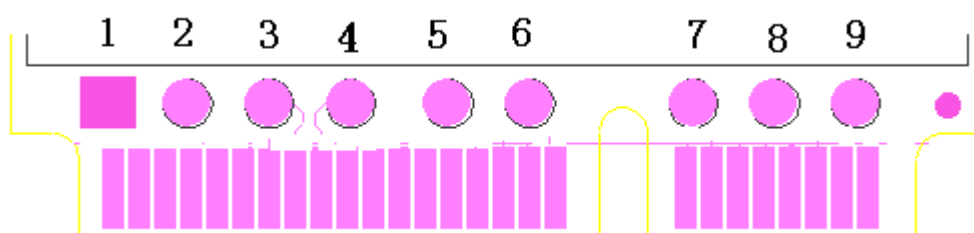

Figure 2-3 Test points of U9507A

Table 2.1 The definition of U9507A test points

SN	Definition
1	U9507A Power Input
2	GND
3	USB DATA+
4	USB DATA-
5	GND
6	USIM Card Reset
7	USIM Card Clock
8	USIM Card Data
9	USIM Card Power

2.1.2 Mini PCIe Interface

A Mini PCIe Interface is used, two primary data interfaces are defined for PCI Express Mini Card: PCI Express and USB. For more information, please refer to the *PCI Express® Mini Card Electromechanical Specification Revision 1.1*. Figure 2-4 show the Mini PCIe Interface.

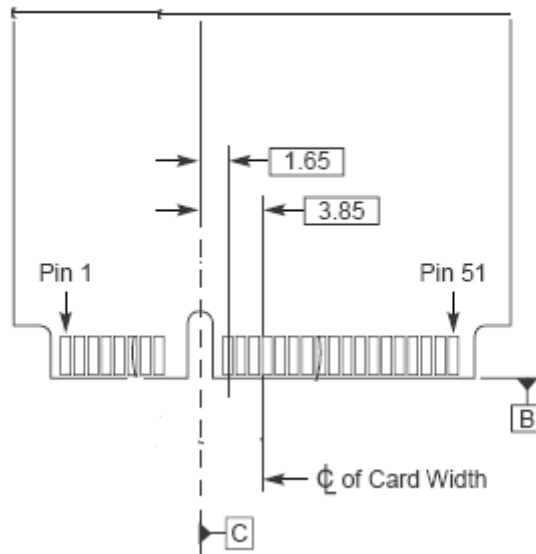

Figure 2-4 The Mini PCIe Interface

For protecting the connector from electro-static, it is better to use the ESD element. And the ESD element should be as close as possible to connector. The definition of the PINs in Mini PCIe Interface is listed in table 2.2 below.



Figure 2-5 The Mini PCIe Interface pin sequence of U9507A

Table 2.2 The definition of Mini PCIe Interface

SN	Definition	Description	Remark
1	MIC_P*	MIC Data+	Audio Interface
3	MIC_N*	MIC Data+-	Audio Interface
5	LINEOUT_P*	Speaker Out+	Audio Interface
7	LINEOUT_N*	Speaker Out-	Audio Interface
9	GND	Ground	
11	VOUT*	Power Output	1.8V
13	NC	NC	NC
15	GND	Ground	
17	NC	NC	NC
19	WAKEUP_IN*	Wakeup The Module	Active low
21	GND	Ground	
23	UART_RXD*	Rx of UART	UART Interface
25	NC*	NC RTS of UART -	
27	GND	Ground	
29	GND	Ground	
31	UART_TXD*	Tx of UART	UART Interface
33	RESET*	External Reset to U9507A	
35	GND	Ground	
37	GND	Ground	
39	VBAT	Power Supply	
41	VBAT	Power Supply	
43	GND	Ground	
45	PCM_CLK*	PCM CLK	PCM Interface
47	PCM_DIN*	PCM Data Input	PCM Interface
49	PCM_DOUT*	PCM Data Output	PCM Interface
51	PCM_SYNC*	PCM Synchronization	PCM Interface
2	VBAT	Power Supply	
4	GND	Ground	
6	NC	NC	NC

8	USIM_VCC	UIM Power	UIM Interface
10	UIM_DATA	UIM Data	UIM Interface
12	UIM_CLK	UIM CLK	UIM Interface
14	UIM_RESET	UIM Reset	UIM Interface
16	NC	NC	NC
18	GND	Ground	
20	W_DISABLE	External Disable signal	Active low signal. This signal is used by the system to disable radio operation on add-in cards that implement radio frequency applications
22	RESET*	External Reset to U9507A	
24	VBAT	Power Supply	
26	GND	Ground	
28	NC	NC	NC
30	NC	NC	NC
32	WAKEUP_OUT*	Wakeup The AP/MCU	
34	GND	Ground	
36	USB_DM	USB Data-	USB Interface
38	USB_DP	USB Data+	USB Interface
40	GND	Ground	
42	PWM_OUT	Led control Signal	
44	NC	NC	NC
46	NC	NC	NC
48	NC	NC	NC
50	GND	Ground	
52	VBAT	Power Supply	

2.1.3 RF interface

U9507A uses HRS's U.FL-R-SMT-1(10) RF connector on the module side. There are three RF connector on U9507A, from right to left: main antenna / GPS antenna* / diversity antenna.

The RF connector is showed in figure 2-6.

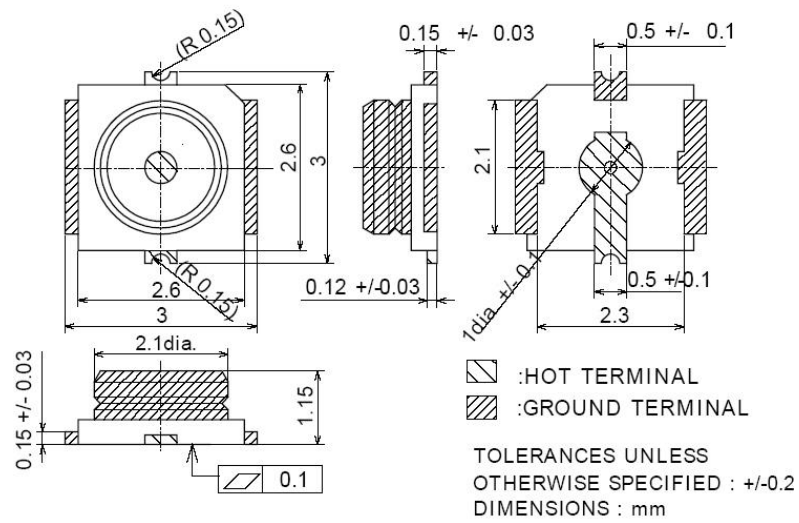

Figure 2-6 The sketch map of RF connector

2.2 U9507A interface application

U9507A supplies multifold functional interface by a Mini PCIe Interface, such as , USIM card interface, USB interface, audio interface*, UART interface*, PCM (Pulse Code Modulation) interface*and power supply interface and so on. The detail information will be given in the follow sections.

2.2.1 RF antenna interface

The impedance of RF antenna is 50Ω.

The three connector is on the top of U9507A;

For minimizing the wasting of RF cable, user should pay more attention to make choice. We suggest choosing the cable that satisfies:

- GSM900/LTE BAND5/LTE Band2/LTE BAND 4/LTE BAND12/WCDMA BAND5/WCDMA BAND8<0dB
- DCS1800/LTE Band13/LTE Band17/WCDMA BAND1 <0dB
- LTE Band28 <0dB

And the antenna should satisfy the table below:

Item	Parameter
------	-----------

Plus(dBi)	GSM	DCS	UMTS
	0	0	0
Type	Omni directional antenna		

2.2.2 RF Line Routing Design

2.2.2.1 Line Arrangement Examples

Several dedicated tools available to calculate line arrangements for specific applications and PCB materials-for example from <http://www.polarinstruments.com/>(commercial software) or from <http://web.awrcorp.com/Usa/Products/Optional-Products/Tx-Line/>(free software).

Embedded Stripline

This figure below shows a line arrangement example for embedded Stripline with 65 μm FR4 prepreg(type:1080) and 710 μm FR4 core(4-layer PCB).

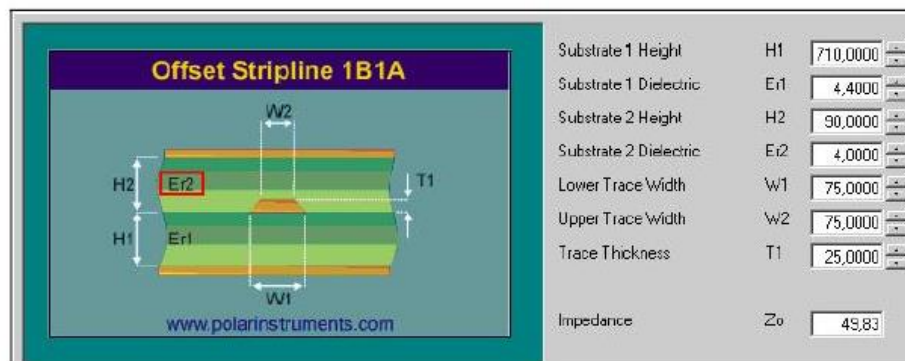

Figure 2-6 embedded Stripline with 65 μm prepreg(1080) and 710 μm core

Micro- Stripline

This section gives two line arrangement examples for micro-stripline.

Micro-Stripline on 1.0mm Standard FR42-Layer PCB

The following two figures show examples with differment values for D1(ground strip separation)

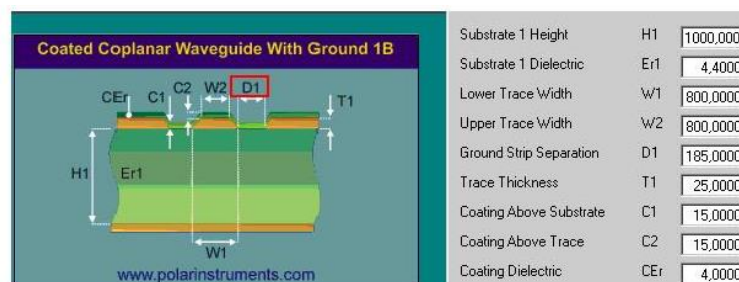

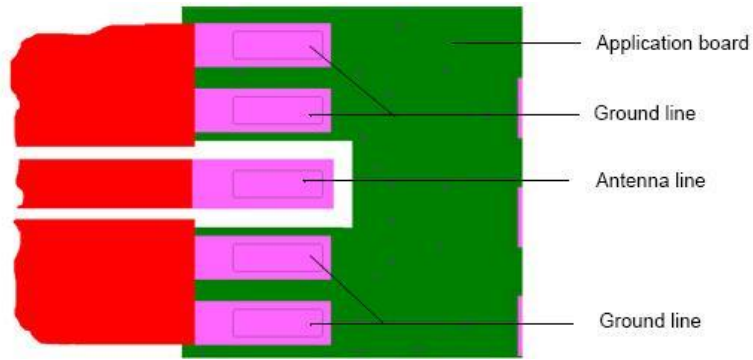

Figure 2-7 Micro-Stripline on 1.0mm standard FR4 2-layer PCB-example 1



Figure 2-8 Micro-Stripline on 1.0mm standard FR4 2-layer PCB-example 2

Micro-Stripline on 1.5mm Standard FR4 2-Layer PCB

The following two figures show examples with different values for D1(ground strip separation)

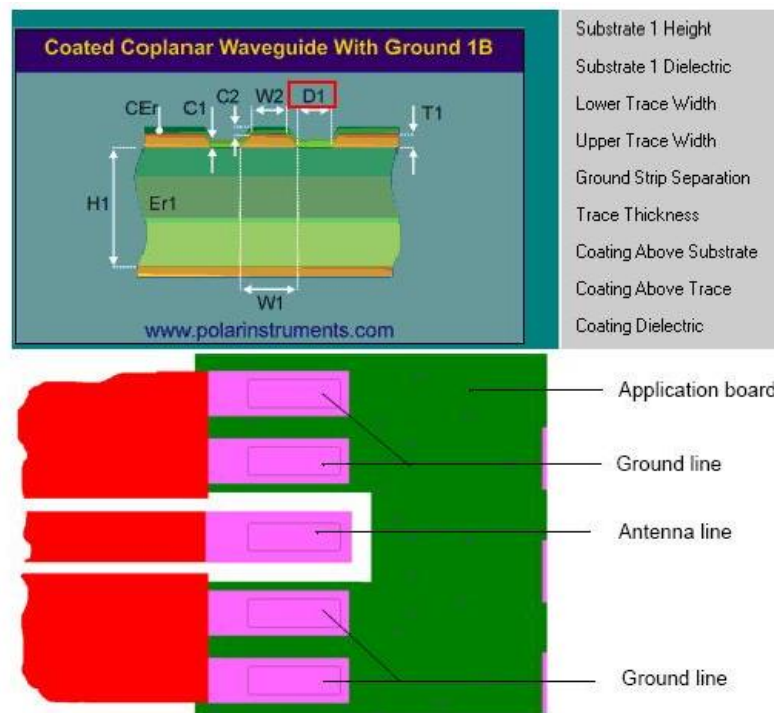

Figure 2-9 Micro-Stripline on 1.5mm standard FR4 2-layer PCB-example 1



Figure 2-10 Micro-Stripline on 1.5mm standard FR4 2-layer PCB-example 2

2.2.2.2 Routing Example

Interface to RF Connector

Figure 2-11 shows a sample connection of a module's antenna pad at the bottom layer of the module PCB with an application PCB's coaxial antenna connector. Line impedance depends on line width, but also on other PCB characteristics like dielectric, height and layer gap. The sample stripline width of 0.33mm is recommended for an application with a PCB layer stack resembling the one of the PLS62-W evaluation board shown in Figure 12. For different layer stacks the stripline width will have to be adapted accordingly.

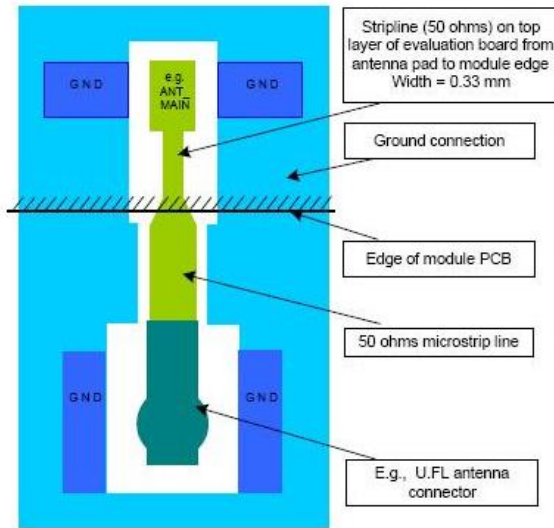

Figure 2-11 Routing to application's RF connector

Layer No.	Construction	Finished thickness (um)
s/m		15
1		20
	Prepreg :1080X1 RC:64%	65
2		25
	CORE: 28mil Hi-Foz 7628x4	706
3		20
	Prepreg :1080X1 RC:64%	65
4		25
s/m		15
	Total thickness (including SMT):	960

Figure 2-12 PLS62-W evaluation board layer table

2.2.3 Power supply and earth

The power supply needed by U9507A, is listed as follow:

1. Voltage range DC:3.3V~4.2V , the power for U9507A working;
2. The earth point: GND;

The description of U9507A Power and GND pins is shown in the table 2.3 below.

Table 2.3 The description of U9507A Power and GND pins

Power input	SN. of the Mini PCIe Interface
VBAT	2, 24, 39, 41,52
GND	4, 9, 15, 18,21, 26, 27, 29, 34, 35, 37, 40, 43, 50

2.2.4 USB interface

2.2.4.1 Description

U9507A offers a high-speed USB interface by Mini PCIe Interface, which submits to USB 2.0 protocol. The detail information is given in table 2.4 below.

Table 2.4 U9507A USB interface description

Signals offered by USB interface	The name of the correlative pins in Mini PCIe Interface	SN. of the Mini PCIe Interface	Description
USB_VBUS	VBAT	2, 24, 39, 41,52	USB power
DM	USB_DM	36	USB Data-
DP	USB_DP	38	USB Data+
GND	GND	4, 9, 15, 18,21, 26, 27, 29, 34, 35, 37, 40, 43, 50	GND

2.2.4.2 Reference circuit

The reference circuit of USB interface is shown in figure 2-7.

- 1) For getting the steady-going USB power supply, it is recommended that a 10uF (C406) filter capacitor and a 22pF (C407) filter capacitor should be used.
- 2) For reducing the BER of USB transmission, it is recommended to add a resistor with values below $10\ \Omega$ to the DM and DP in USB interface. Just like the resistors R408 and R409 in figure 2-7.
- 3) For avoiding the electro-static in USB interface, it is recommended to use the ESD element. Just like the voltage dependent resistors RV406, RV407 and RV408 with the static capacitance values below 3pF.

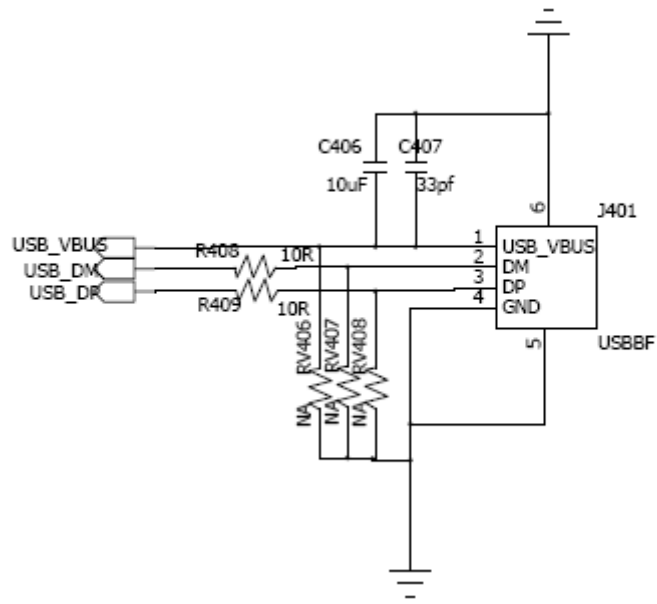

Figure 2-13 The reference circuit of USB interface

4) The USB interface input the voltage from USB_IN .For keeping the USB in U9507A module working unfaillingly, a voltage protection circuit should be added by user between the USB_IN of USB interface and the USB_VBUS PIN of U9507A. It is shown in figure 2-8 with the red circle 2. In the voltage protection circuit, D603 is a Zener diode with a breakdown voltage value of 5.1v which could keep the voltage on the USB_VBUS PIN of U9507A not more than 5.1v. D602 is a Schottky Diode, and R621 is a resistor with the value 1KΩ . On the other hand the voltage coming from the USB_IN also could be converted by using a DC/DC converter to 3.6v and then be sent to VBAT PIN of U9507A. It is shown in figure 2-8 with the red circle 1.

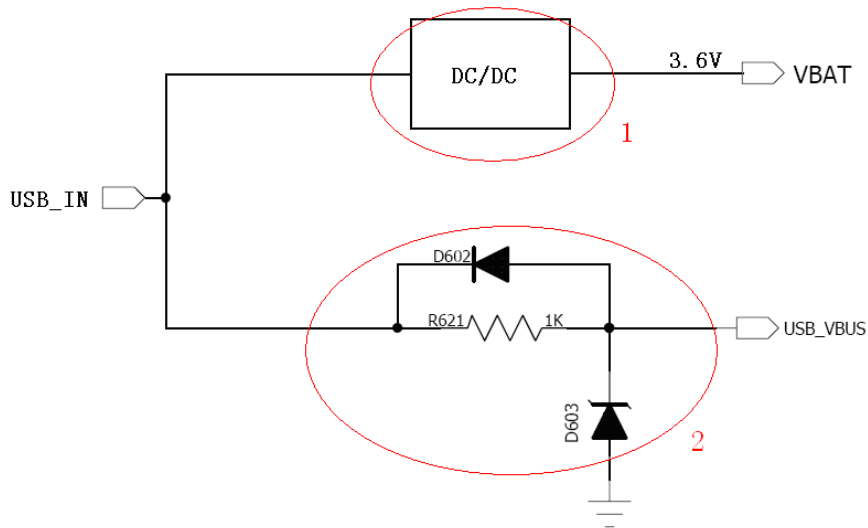

Figure2-14 The reference of voltage protection circuit

2.2.5 USIM interface

U9507A supports LTE, UMTS and GSM operation mode.. USIM card as well as SIM card can be used.

2.2.5.1 Description

U9507A offers USIM card interface by Mini PCIe Interface. And it can be used in LTE,UMTS and GSM/GPRS/EDGE networks. The table 2.5 gives the more detail information.

Table 2.5 U9507A USIM card interface description

Signals offered by USIM interface	The name of the correlative pins in Mini PCIe Interface	SN. of the Mini PCIe Interface	Description
DATA	UIM_DATA	10	UIM card data
CLK	UIM_CLK	12	UIM card CLK
RST	UIM_RESET	14	Reset signal
VCC	USIM_VCC	8	UIM card power
GND	GND	4, 9, 15, 18,21, 26, 27, 29, 34, 35, 37, 40, 43, 50	GND

2.2.5.2 Reference circuit

The reference circuit of USIM interface is shown in figure 2-9.

- 1) The DATA line of USIM is connected to SIM power by a pull-up resistor, and the reference value is 15K Ω .
- 2) For avoiding the instantaneous voltage overflowing, the resistor with the reference value 22 Ω can be used for the DALA, CLK and RST. Just like the resistors R307, R308 and R309 in figure 2-8.
- 3) For avoiding the electro-static in USIM socket, it is recommended to use the ESD element to the DATA, CLK and VCC. Just like the voltage dependent resistors RV301, RV302, RV303 and RV304 in figure 2-8. And the ESD element should close to the USIM socket as close as possible.
- 4) For getting the more smooth USIM power supply, it is recommended to use the filter capacitors. Just like C311 and C312 in figure 2-8, and their reference values are 33pF and 100nF.
- 5) In order to remove the unwanted peak signal and the elimination high frequency interference which produces on RST

and CLK, the filter capacities (C310, C309) can be placed in RST and the CLK end, the reference value is 33pF.

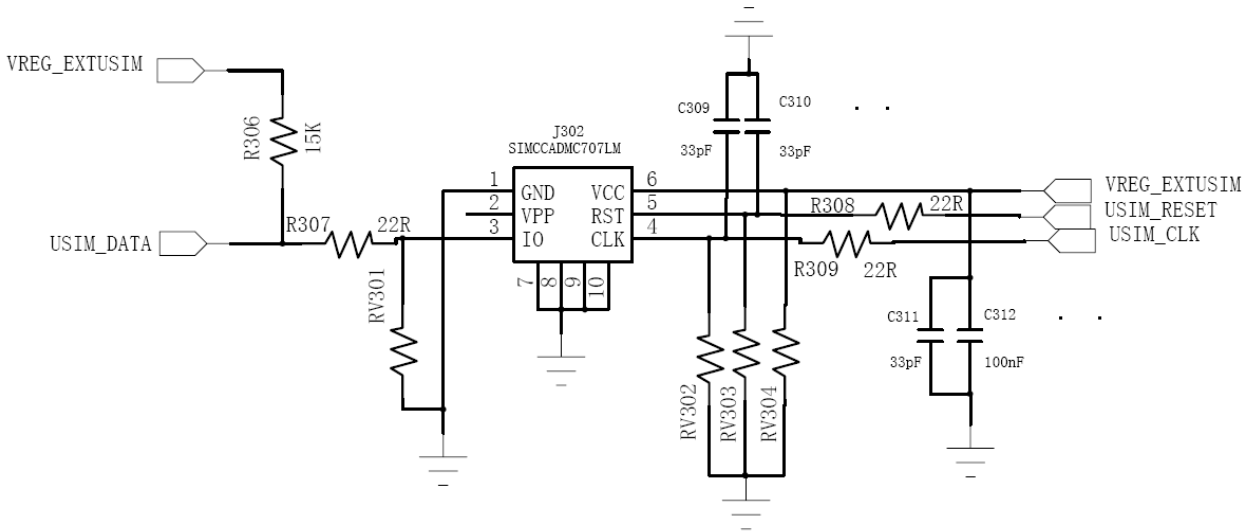

Figure 2-15 The reference circuit of USIM interface

2.2.6 Audio interface*

The audio signals here include a pair of input difference signals (MIC1_P, MIC1_N) and a pair of output difference signals (EAR1OP,EAR1OR) . And the Audio interface here includes the earphone jack and the test points.

2.2.6.1 Description

The audio signals offered by U9507A are described in the table 2.7 below.

Table 2.7 U9507A audio signal description

The name of the correlative pins in Mini PCIe Interface	SN. of the Mini PCIe Interface	Description
LINEOUT_P	5	Audio output data+
LINEOUT_N	7	Audio output data-
MIC_P	1	Audio input data+
MIC_N	3	Audio input data-

2.2.6.2 The connection between audio I/O and earphone

The audio I/O signals offered by U9507A can be connected to a stereo earphone jack. The more detail information

about connection between earphone jack and the Mini PCIe Interface is shown in table 2.8 below. And the information about test points is shown in table 2.1 above.

Table 2.8 The connection between earphone jack and the Mini PCIe Interface

The PIN name of earphone jack	he name of the correlative pins in Mini PCIe Interface	SN. of the Mini PCIe Interface	Description
Left Speaker	LINEOUT_P	5	The left output of stereo
Right Speaker	LINEOUT_N	7	The right output of stereo
MIC	MIC_P	1	The microphone input
PGND	GND	50	Analog ground signal

2.2.6.3 The connection between audio I/O and phone handle

The audio I/O signals offered by U9507A can be connected to a phone handle. The more detail information about connection between phone handle and the Mini PCIe Interface is shown in table 2.9 below.

Table 2.9 The connection between phone handle and the Mini PCIe Interface

Signals offered by phone handle	The name of the correlative pins in Mini PCIe Interface	SN. of the Mini PCIe Interface	Description
EAR_P	LINEOUT_P	5	Audio output data+
EAR_N	LINEOUT_N	7	Audio output data-
MIC_P	MIC_P	1	Audio input data+
MIC_N	MIC_N	3	Audio input data-

2.2.6.4 Reference circuit

The reference circuit of audio interface is shown in figure 2-11.

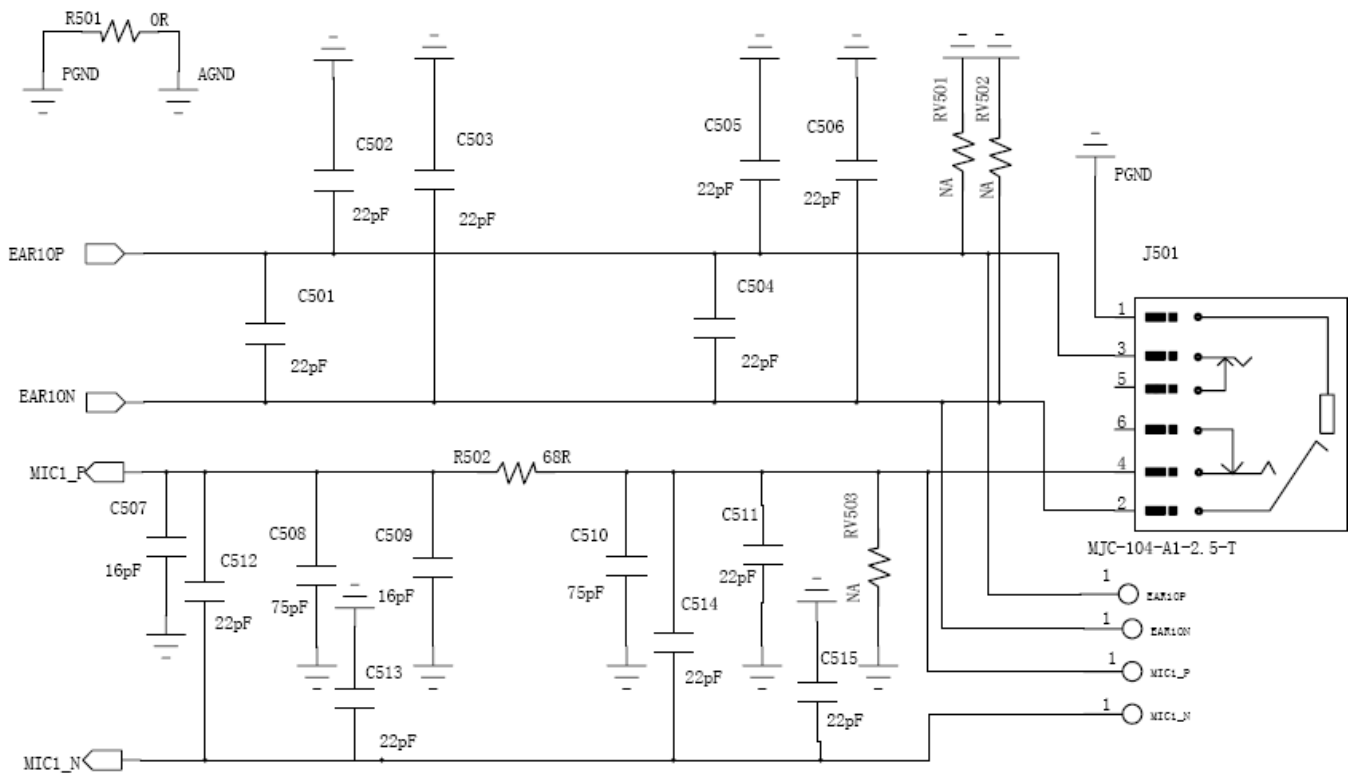

Figure 2-16 The reference circuit of audio interface

- 1) The audio output signals, a pair of difference signal, export to two receivers. And they are not the real traditional dimensional sound.
- 2) It is recommended to use the smoothing capacitor or smoothing circuit for reducing the undesired signal between different frequency bands. Just like what is shown in figure 2-9.
- 3) For avoiding the electro-static, it is recommended to use the ESD element. Just like the voltage dependent resistors RV501, RV502 and RV503 in figure 2-10.
- 4) Designers needs gets up the acoustic train signaling analogous circuit ground terminal and the entire digital circuit earth end connection, bead or 0 ohm resistance can be used.
- 5) In the chart J501 is a four section of earphone jack schematic diagram electric circuit, you can see audio output signal connecting difference signal while audio input signal connecting one negative signal.

2.2.7 PCM interface*

U9507A offers Micro the PCM interface and the SPI interface by Mini PCIe Interface. And the SPI interface is simulated by GPIO PIN.

2.2.7.1 PCM interface description

The information about PCM interface offered by U9507A is described in table 2.10 below.

Table 2.10 U9507A PCM interface description

Signals offered by PCM	The name of the correlative pins in Mini PCIe Interface	SN. of the Mini PCIe Interface	Description
SYNC	PCM_SYNC	51	PCM Synchronous Signal
CLK	PCM_CLK	45	PCM CLK
D ATA_IN	PCM_DIN	47	PCM Input
D ATA_OUT	PCM_DOUT	49	PCM Output

2.2.8 UART interface*

U9507A offers a UART interface (RS232) by Mini PCIe Interface for debugging.

2.2.8.1 Description

The information about UART interface offered by U9507A is described in table 2.12 below.

Table 2.12 U9507A UART interface description

Signals offered by UART	The name of the correlative pins in Mini PCIe Interface	SN. of the Mini PCIe Interface	Description
RX	UART_RXD	23	
TX	UART_TXD	31	
GND	GND	4, 9, 15, 18,21, 26, 27, 29, 34, 35, 37, 40, 43, 50	

2.2.8.2 Reference circuit

The reference circuit of UART interface is shown in figure 2-12.

1) As the UART of U9507A can only supply TTL level while the PC serial port level is the RS232 level, the signal level between them must use level transformation chip. The reference IC is SP3238EEA which produces by SIPEX, as

shown in Figure 2-11. J401 is a 9 needle serial port plugs, we can use it to connect U9507A and PC.

2) For avoiding the electro-static, it is recommended to use the ESD element to the signal line of the UART socket. Just like the voltage dependent resistors RV401, RV402, RV403, RV404 and RV405 in figure 2-11. And the ESD element should close to the socket as close as possible.

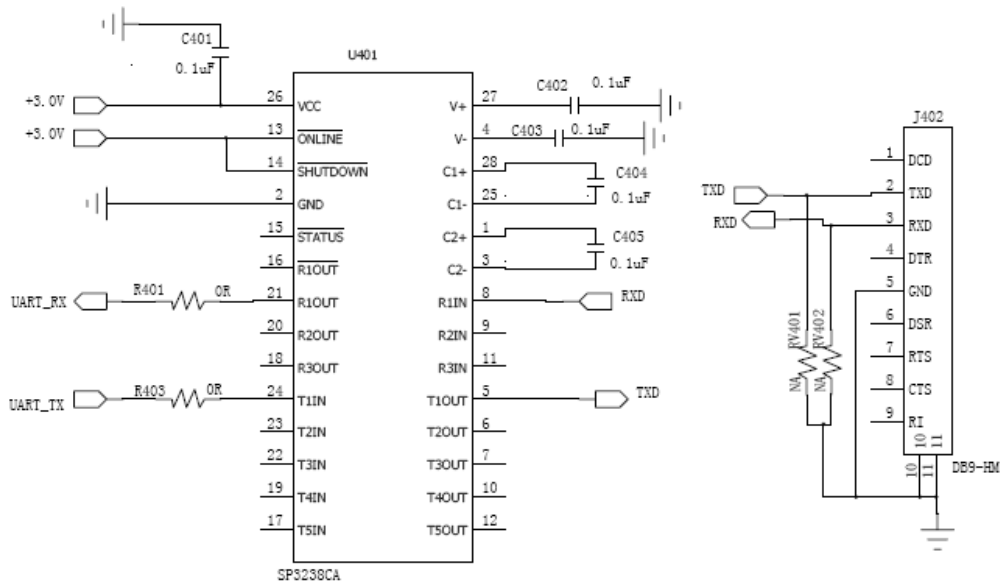

Figure 2-17 The reference circuit of UART interface

2.2.9 LED control

2.2.9.1 Description

There is a pins for LED control in the Mini PCIe Interface. And the detail information is given in table 2.13 below.

Table 2.13 U9507A LED control description

The name of the correlative pins in Mini PCIe Interface	SN. of the Mini PCIe Interface	Description
PWM_OUT	42	Led control Signal

And the U9507A status displayed by LEDs is listed in table 2.14 below.

Table 2.14 LED display description

LED	Status	Description
Green	Flicker quickly (100ms On/800ms Off)	Networks searching

	Flicker slowly(100ms On/3000ms Off)	Registered in 3G networks
	Always On	Connected to 3G networks, but no data transmitting
	Off	Closed or error(No SIM card or failed in registering networks)

2.2.9.2 Reference circuit

The reference circuit for LED is shown in figure 2-13.

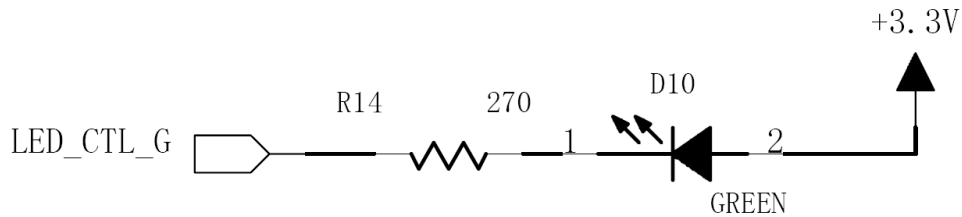

Figure 2-18 The reference circuit of LED control

- 1) The LED control pin connects to the cathode of LED. And the anode of LED connects to the +3.3v power in figure 2-12.
- 2) The value of electrical current must be below than 10mA. And the reference value is 5mA. So the current-limiting resistor may be used. Just like the resistor R14 in figure 2-12
- 3) The reference circuit given is for the Green LED, and it is the same for the Red one.

2.2.10 Others*

U9507A also offers some other functional interfaces besides those which have been described above.

These signals are listed in table 2.15 below.

Table 2.15 The other signals offered by U9507A

The name of the correlative pins in Mini PCIe Interface	SN. of the Mini PCIe Interface	Description
RESET	33, 22	Reset signal for U9507A
VOUT	11	VREG_MSMP Output, 1.8V

- 1) U9507A offers a power supply named VREG_MSMP, its value is +1.8V and the Max. value of electric current is 100mA.
- 2) EXT_RST_N is used for reset the U9507A module. And U9507A will be reseted just by putting the EXT_RST_N to GND;

For only keeping the SMPL (Sudden momentary power losing) timer while Sudden momentary power losing, a capacitor can be used inside of battery. And the correlativity between the capacitance and the holding time is listed in

table 2.16.

Table 2.16 the correlativity between the capacitance and the holding time

The capacitance	The Packaging (X5R)	The holding time
1.5uF	0805	0.5
3.3uF	0805	1.0
4.7uF	0805	1.5
6.8uF	1206	2.0

3. U9507A key features

The U9507A module has features such as internet access, SMS, GPS, phone book and audio. The features are described in following sections. For detail information about AT commands, please make refers to the related documents.

3.1 Internet access

AT commands can be used for selecting network mode, setting the network search mode, setting register mode, querying network signal strength, setting APN and so on. The related AT commands are listed as follows:

Network Mode Set: AT+MODODREX=<mode >

Network Mode Query: AT+MODODREX?

Network Mode Service Query: AT+MODPRF?

Network Query: AT+PSRAT

Querying network signal strength: AT+CSQ

PIN and PUK Remain Times Query: AT+CPNNUM

APN Set: AT+CGDCONT=1,"IP","CMNET"

Dial up Access: ATDT*99***1#

PS DATA CALL Disconnecting: ATH

3.2 SMS

The SMS feature is implemented by AT commands. You can set the service center address, switch message format, enable/disable receiving message report, delete message, preview message, receive/send message and so on.

The related AT commands are listed as follow:

New Message Indication: AT+CNMI

Message Send: AT+CMGS

Message Preview: AT+CMGPR

Message Delete: AT+CMGD

Message format Switch: AT+CMGF

Service Center Address Set: AT+CSCA

Receiving Message Report enable/disable: AT+CNMI=2,1,0,1,0

3.3 GPS

GPS functions are only available in the U9507A module. The related AT command as follow:

AT+GPSFIX originate GPS request

AT+GPSCFG configure GPS parameter

3.4 Phonebook

The Phonebook feature is implemented by AT commands. You can set the phonebook storage location, read phone number, write phone number and delete phone number and so on.

The related AT commands are listed as follow:

AT+CPBS=<storage> set the storage location

AT+CPBR=<index> read phone number

AT+CPBW=[<index>][,<number>,<type>,<text>]] write phone number on the phone.

AT+CPBW=[<index>] delete phone number.

AT+CPBF=<findtext> find the phone number according to the findtext.

4. Application Illustration

4.1 Dial-up procedure

The type “S” means the AT Command sent to U9507A, and the type “R” means Respond from U9507A.

SN.	Type	AT Command/Respond	Explain
1	S	AT+CPIN?	SIM card querying
2	R	READY	
3	S	AT+CPNNUM	PIN And PUK querying

4	R	PIN1=3; PUK1=10; PIN2=0; PUK2=8	
5	S	ATD10086;	Doing cs call
6	R	AT+CHUP	Hung up the cs call
7	S	AT+CIMI	Get IMSI
8	R	460020177608847	IMSI, by which APN is selected
9	S	AT+CGDCONT=1,"IP","CMNET"	Set APN
10	R	OK	
11	S	ATDT*99***1#	Dial-up
12	S	ATH	Disconnect the PS call

4.2 SMS

4.2.1 Message Format

U9507A supports two kinds of message format, PDU and TEXT which can be set by AT command AT+CMGF, AT+CMGF=0 means PDU format, and AT+CMGF=1 means TEXT format.

4.2.2 Set Message Storage Location

The command AT+CPMS=<mem1>,<mem2>,<mem3> is used to set message storage location.

<mem1>, <mem2>, <mem3> can be set as SM and ME, SM means SIM card, ME means the U9507A module.

<mem1>: The parameter set here means memory storage used as read and delete message function. It can be operated by the followed AT commands: AT+CMGL, AT+CMGR and AT+CMGD;

<mem2>: The parameter set here means memory storage used as writing and send message function. It can be operated by the followed AT commands: AT+CMSS and AT+CMGW;

<mem3>: Received messages will be storage in this memory if routing to PC is not set;

Response:

If no error:

+CPMS:<used1>,<total1>,<used2>,<total2>,<used3>,<total3>

OK

<used1, 2, 3> Number of messages currently storage in <mem1, 2, 3>

<total1, 2, 3> Number of message capacity of <mem1, 2, 3>

If error:

+CMS ERROR:<err>

The command AT+CPMS? is used to display the remained capacity of memory.

AT+CPMS?

Response:

If no error:

+CPMS:<mem1>,<used1>,<total1>,<mem2>,<used2>,<total2>,<mem3>,<used3>,<total3> OK

If error:

+CMS ERROR

4.2.3 PDU Format

Sending:

The type “S” means the AT Command sent to U9507A, and the type “R” means Respond from U9507A.

SN.	Type	AT Command/Respond	Explain
1	S	AT+CSCS=" UCS2"	Select TE character set
2	R	OK	
3	S	AT+CMGF=0	Select message PDU format
4	R	OK	
5	S	AT+CMGS=26 0011000D91683198916718F30000000CC8329BFD0 65DDF72363904 <ctrl-Z>	Send message
6	R	+CMGS: 2 OK	Send successfully

Writing message to memory:

The type “S” means the AT Command sent to U9507A, and the type “R” means Respond from U9507A.

SN.	Type	AT Command/Respond	Explain
1	S	AT+CMGW=26 0011000D91683198916718F3000000CC8329BFD0 65DDF72363904 <ctrl-Z>	Write a message
2	R	+CMGW: 6 OK	Memory location index 6 of the stored message is returned.

Receiving message:

+CMTI: "SM",0

Means new received message in the memory located from index 0.

Reading message:

The type "S" means the AT Command sent to U9507A, and the type "R" means Respond from U9507A.

SN.	Type	AT Command/Respond	Explain
1	S	AT+CMGR=0	Read message has been received in the memory location index 0
2	R	+CMGR: 0,,24 0891683108200905F0240D91683198916718F3000 880509111258023047A7A8C03 OK	Read successfully

Deleting message:

The type "S" means the AT Command sent to U9507A, and the type "R" means Respond from U9507A.

SN.	Type	AT Command/Respond	Explain
1	S	AT+CMGD=0	Delete message from preferred memory location index 0.
2	R	OK	Delete successfully

4.2.4 TEXT Format

Sending:

The type “S” means the AT Command sent to U9507A, and the type “R” means Respond from U9507A..

SN.	Type	AT Command/Respond	Explain
1	S	AT+CSCS=" GSM"	Select TE character set
2	R	OK	
3	S	AT+CMGF=1	Select message TXT format
4	R	OK	
5	S	AT+CMGS="13572034257" > 1233455664788666555 <ctrl-Z>	Send message
6	R	+CMGS: 4 OK	Send successfully

Writing message to memory:

The type “S” means the AT Command sent to U9507A, and the type “R” means Respond from U9507A..

SN.	Type	AT Command/Respond	Explain
1	S	AT+CMGW="13572034257" > 11111114 <ctrl-Z>	Write a message
2	R	+CMGW: 8 OK	Memory location index 8 of the stored message is returned.

Receiving message:

+CMTI: "SM",1

Means new received message in the SIM card located index is 1.

Reading message:

The type “S” means the AT Command sent to U9507A, and the type “R” means Respond from U9507A..

SN.	Type	AT Command/Respond	Explain
1	S	AT+CMGR=8	Read message has been received in the memory location index 8
2	R	+CMGR: 0,,24 +CMGR: "STO UNSENT","13572034257", 11111114 OK	Read successfully

Deleting message:

The type "S" means the AT Command sent to U9507A, and the type "R" means Respond from U9507A. The type "S" means the AT Command sent to U9507A, and the type "R" means Respond from U9507A.

SN.	Type	AT Command/Respond	Explain
1	S	AT+CMGD=8	Delete message from preferred memory location index 8.
2	R	OK	Delete successfully

4.2.5 SMS Service Center Address Setting

The user can set the SMS service center address, TP-Validity-Period and SMS Data Coding Mode.

SN.	Type	AT Command/Respond	Explain
1	S	AT+CSCA="+8613800201500",145	Set the SMS service center address, and the address will be kept in SIM card.
2	R	OK	
3	S	AT+CSMP=17,167,0,8	Set the TP-Validity-Period as 167 (24 hours) ,and the SMS Data Coding Mode as UCS2
4	R	OK	

Remark:

- 1) TP-MTI supports SMS-DELIVER, SMS-SUBMIT and SMS-STATUS-REPORT, while not support SMS-DELIVER-REPORT, SMS-SUBMIT-REPORT and SMS-COMMAND.
- 2) TP-PID is 0 by default while TPDU is sending or saving.
- 3) The Min. length of <pdu> is 8 and the Max. length of <pdu> is 164 while TPDU is sending or saving,.

- 4) The parameter <stat> can only be 2 for the command AT+CMGW.
- 5) In TEXT Format, the parameter <fo> can be 17 and 49, the parameter <pid> can only be 0, the parameter <dc> can be 0~31 and the parameter <vp> can be 0~255 for AT+CSMP command
- 6) In TEXT Format, the parameter <stat> can only be "STO UNSENT" for the command AT+CMGW

4.3 PHONE BOOK

4.3.1 Set Phone Book Storage Location

Phone book storage location can be set by AT command AT+CPBS. The AT command can be used in three ways.

Performing AT+CPBS? will return the current storage location of the phone book. Such as +CPBS:<storage>[,<used>,<total>].The parameter <total> indicated how many phone numbers can be stored on the phone. The parameter <used> indicates how many phone numbers have been stored.

Performing AT+CPBS=? will return all the storage type which the phone supports. Such as +CPBS: (list of supported <storage>s).

We can use AT+CPBS=<storage> to set storage location. There are six types storage location. It's follow as:

- "LD" --store the recently call number which have dialed (SIM).
- "MC" --store the recently call number which haven't answered.
- "RC" --store the recently call number which have been answered.
- "ON" -- store the phone number of itself.
- "ME" --NVRAM storage
- "SM" --SIM storage

4.3.2 Read Phonebook entries

When you want to read phonebook entries, you can use AT command AT+CPBR.

Performing AT+CPBR=? will list of supported index, phone number length and text length.

Performing AT+CPBR=<index1>[,<index2>] will return the content of the phonebook entry of index1. If we use index1 and index2 at the same time ,it will return all the entries between index1 and index2. Such as

[+CPBR:<index1>,<number>,<type><text>[[...]<CR><LF>+CPBR:<index2>,<number>,<type><text>]]

The parameter <type> include 129 and 145.145 indicate which is a international phone number. 129 indicate which is a unknown type number.

The parameter <text> is the tag of the number.

4.3.3 Write phonebook entry

When you want to write a phonebook entry on the phone, you can use AT commande AT+CPBW.

Performing AT+CPBW=? will return list of supported index, max length of phone number, list of supported phone number types and max length of text.

We can use the command "AT+CPBW=[<index>][,<number>[,<type>[,<text>]]]" to write number on the phone. If the parameter <number> is NULL, the command will delete the phone number on the phone of index.

4.3.4 Find phonebook entries

We can use AT command AT+CPBF when we want to find the entry according to the text.

Performing AT+CPBF=? will return the max length of phone number and the max length of text. Such as +CPBF:[<nlength>],[<tlength>].

When we want to find a entry, we can give the text of the phone number ,and according to the text, we use AT+CPBF=<findtext> to find the number we want.

4.4 AUDIO

Audio functions are only available in the U9507A module.

4.4.1 Originate Call

ATD<str>[:] Mobile originate call to dial a number. <str>: string of dialing digits, dialing digits:0~9 <;> only required to set up voice call , return to command state.

The Max length of dialing digits is 20; The prefix "+" is not counted to the length of dialing digits.

4.4.2 Answer a incoming call

ATA using the command can answer a incoming call.

ATA responds coming call by RING. It will display the calling phone number if CLIP (Calling Line Identity Indication Presentation) function is set. ATA will return NO CARRIER for responding hang up after connection.

4.4.3 Disconnect call

AT+CHUP using the command can disconnect a connection.

5. Safety information

1. Don't let the product work at extreme low or high temperature -10°C~55°C
2. Don't use more than 4.2 V external power supply.
3. RF exposure hazard warning

This device generates and radiates radio-frequency energy.In order to comply with radio-frequency exposure guidelines for an uncontrolled environment.

This equipment must be installed and operated while maintaining a minimum body to antenna distance of 20cm.The using antenna should not exceed 0dBi

6. FCC Caution

FCC Caution:

(1)Exposure to Radio Frequency Radiation. This equipment must be installed and operated in accordance with provided instructions and the antenna(s) used for this transmitter must be installed

to provide a separation distance of at least 20 cm from all persons and must not be collocated or operating in conjunction with any other antenna or transmitter. End-users and installers must be provided with antenna installation instructions and transmitter operating conditions for satisfying R F

exposure compliance.

(2)Any changes or modifications not expressly approved by the grantee of this device could void the

user's authority to operate the equipment.

(3)This Transmitter must not be co-located or operating in conjunction with any other antenna or transmitter.

(4)Changes or modifications to this unit not expressly approved by the party responsible for compliance could void the user authority to operate the equipment.

(5) the modules FCC ID is not visible when installed in the host, or (6) if the host is marketed so that

end users do not have straight forward commonly used methods for access to remove the module so

that the FCC ID of the module is visible; then an additional permanent label referring to the enclosed

module: Contains Transmitter Module FCC ID: XHZU9507A

Appendix: Mechanical dimensions of U9507A

The following are Mechanical dimensions of U9507A bottom view, side view and top view. (Unit: mm)

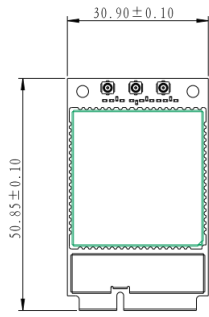

Top View

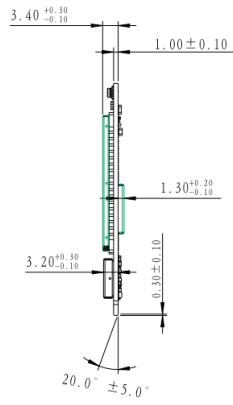

Side View

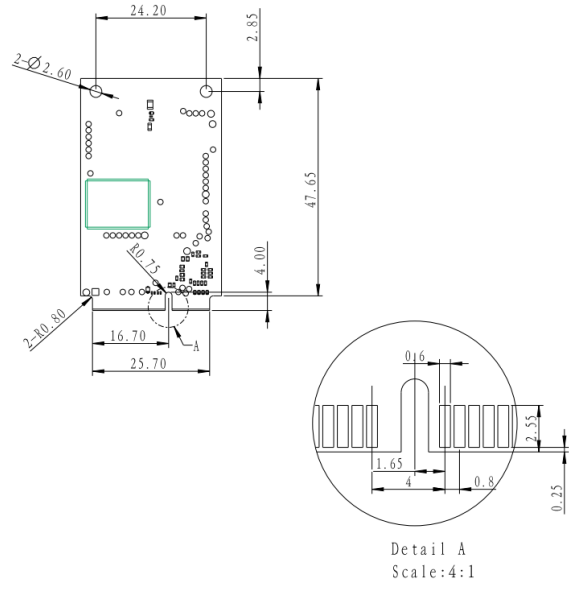

Bottom View