

7.5.5. Test Result

Test Mode	Data Rate (Mbps)	Channel No.	Frequency (MHz)	Limit	Result
802.11b	1	01	2412	20dBc	Pass
802.11b	1	06	2437	20dBc	Pass
802.11b	1	11	2462	20dBc	Pass
802.11g	6	01	2412	20dBc	Pass
802.11g	6	06	2437	20dBc	Pass
802.11g	6	11	2462	20dBc	Pass
802.11n-HT20	6.5	01	2412	20dBc	Pass
802.11n-HT20	6.5	06	2437	20dBc	Pass
802.11n-HT20	6.5	11	2462	20dBc	Pass
802.11n-HT40	13.5	03	2422	20dBc	Pass
802.11n-HT40	13.5	06	2437	20dBc	Pass
802.11n-HT40	13.5	09	2452	20dBc	Pass
BLE	1	00	2402	20dBc	Pass
BLE	1	19	2440	20dBc	Pass
BLE	1	39	2480	20dBc	Pass

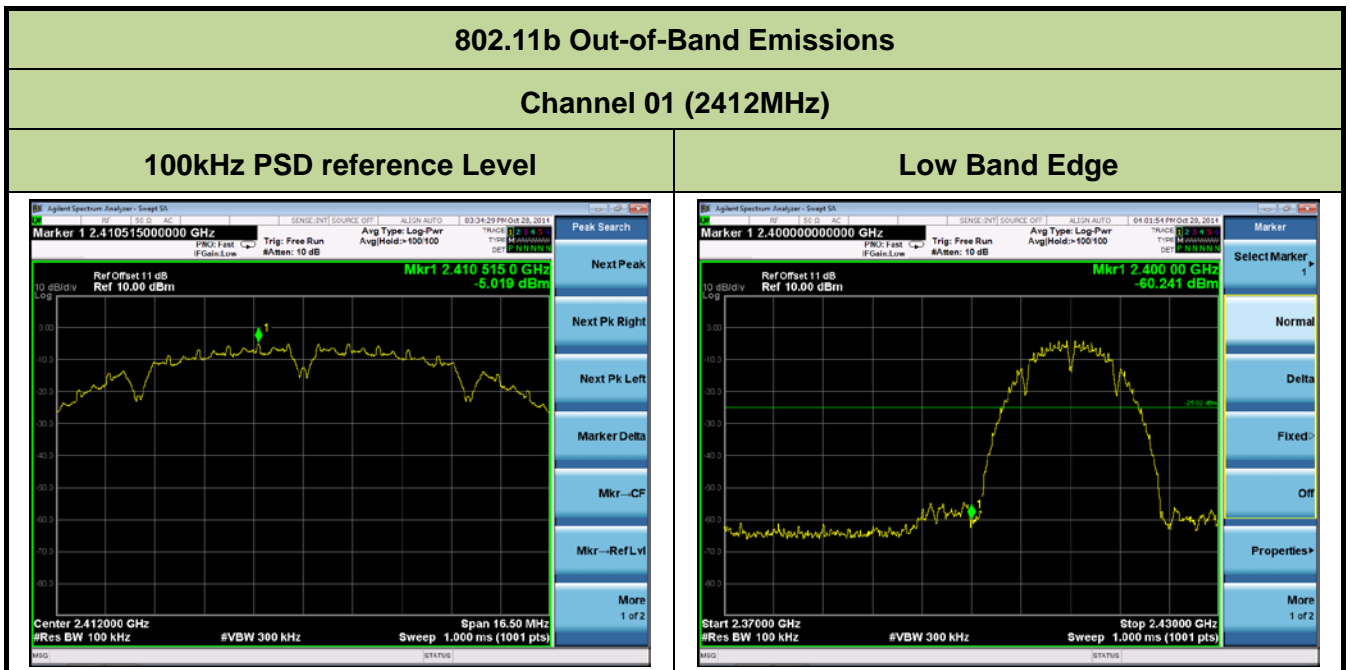

Spurious Emission 30MHz ~ 25GHz



Channel 06 (2437MHz)

100kHz PSD reference Level



Spurious Emission 30MHz ~ 25GHz



Channel 11 (2462MHz)

100kHz PSD reference Level



High Band Edge

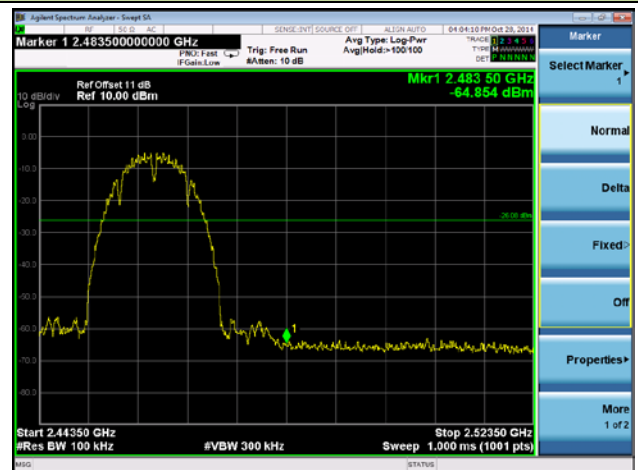

Spurious Emission 30MHz ~ 25GHz

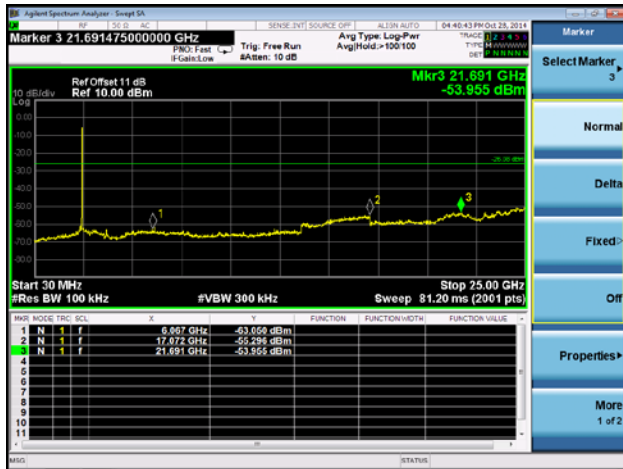

802.11g Out-of-Band Emissions

Channel 01 (2412MHz)

100kHz PSD reference Level

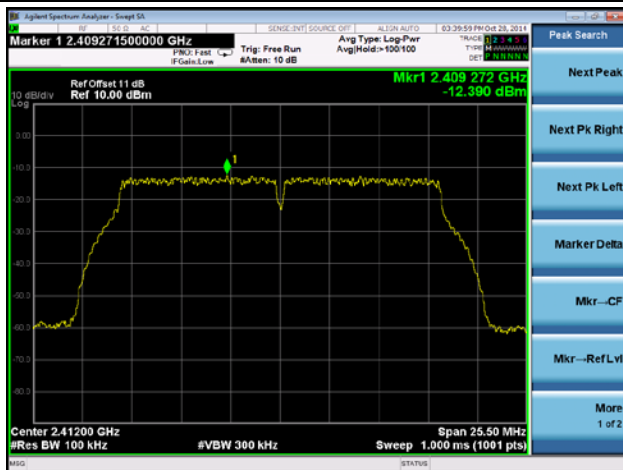

Low Band Edge

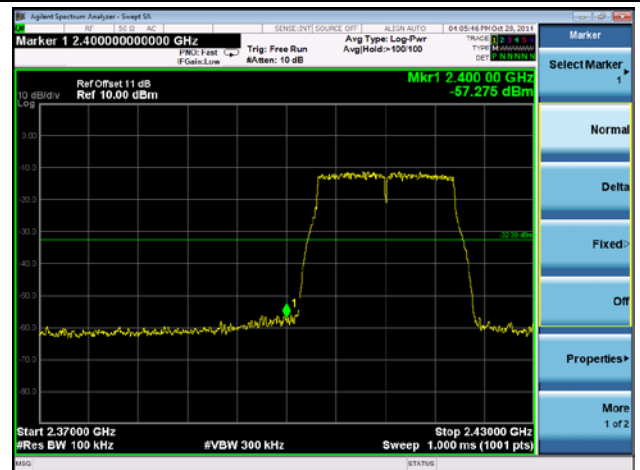

Spurious Emission 30MHz ~ 25GHz

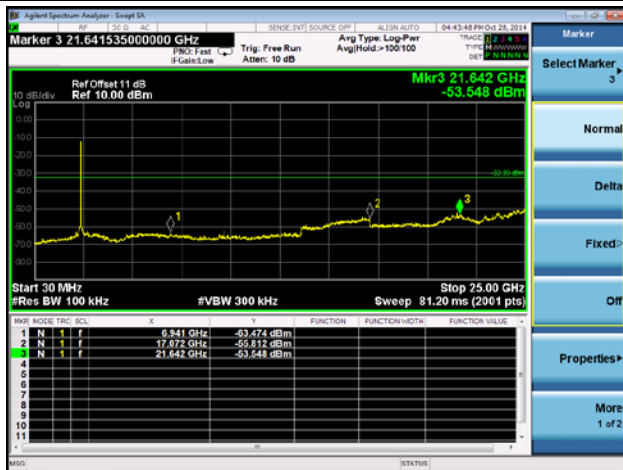

Channel 06 (2437MHz)

100kHz PSD reference Level

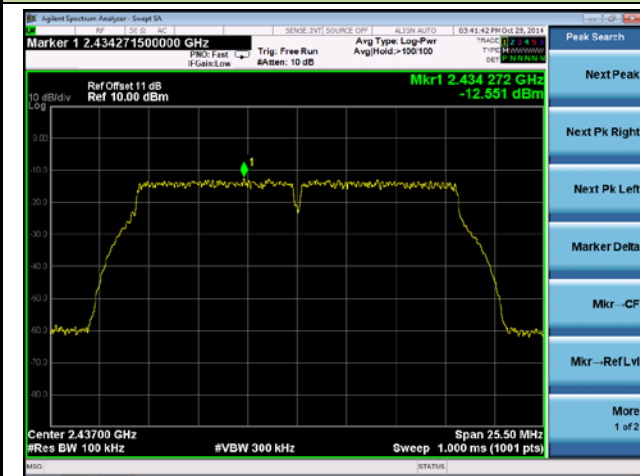

Spurious Emission 30MHz ~ 25GHz

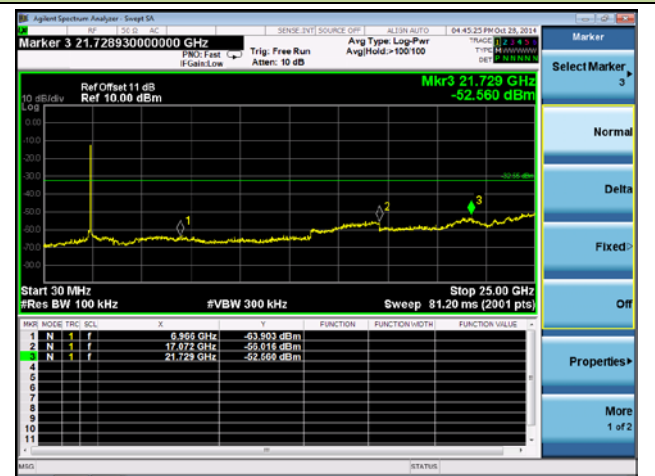

Channel 11 (2462MHz)

100kHz PSD reference Level

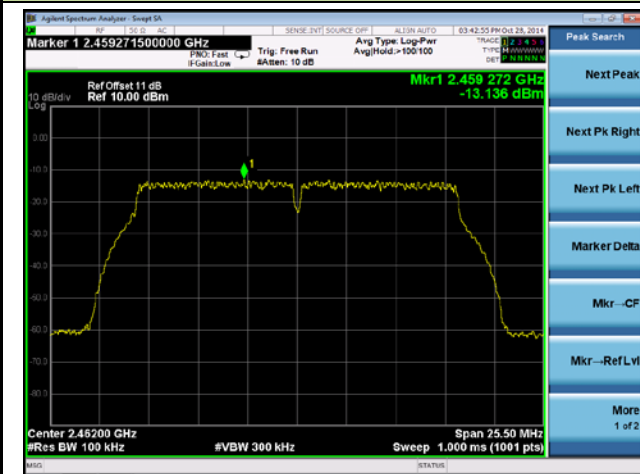

High Band Edge

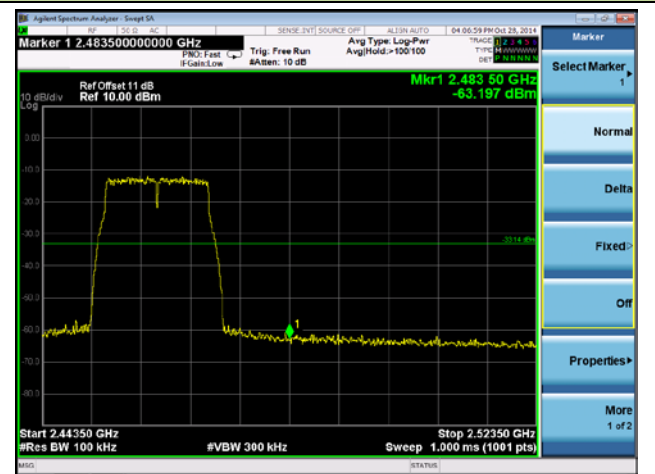

Spurious Emission 30MHz ~ 25GHz

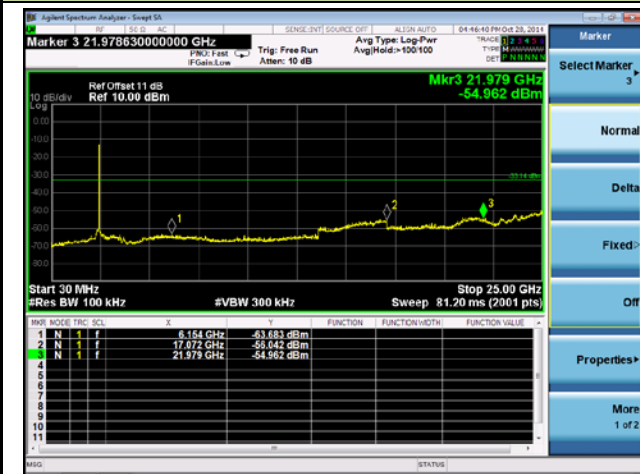

802.11n-HT20 Out-of-Band Emissions

Channel 01 (2412MHz)

100kHz PSD reference Level

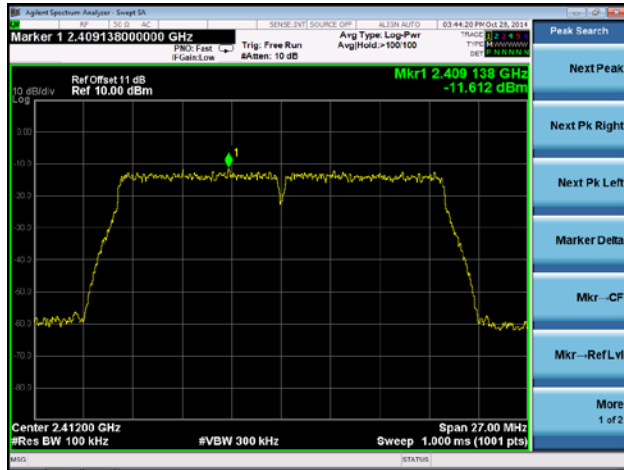

Low Band Edge

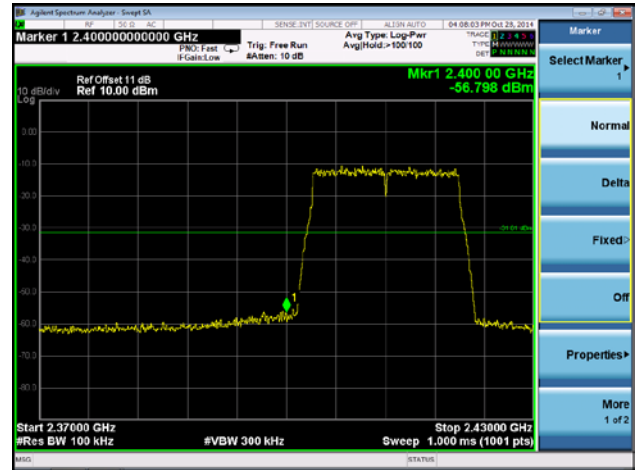

Spurious Emission 30MHz ~ 25GHz

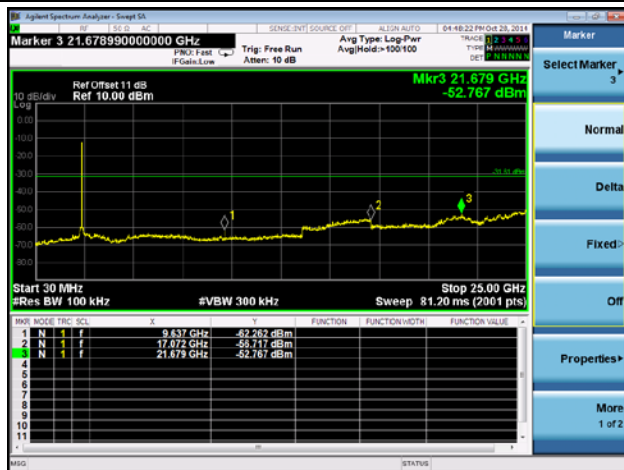

Channel 06 (2437MHz)

100kHz PSD reference Level

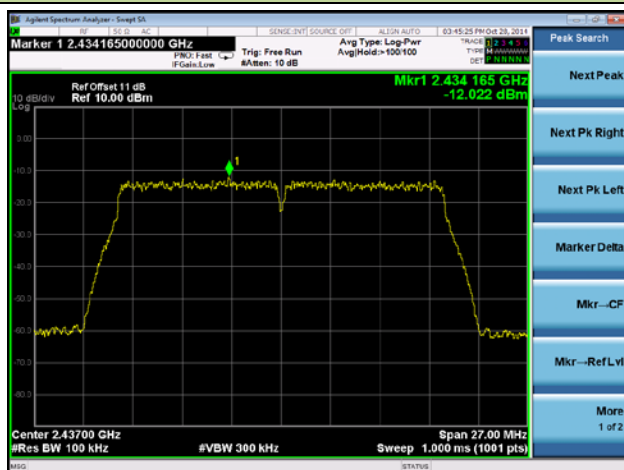

Spurious Emission 30MHz ~ 25GHz

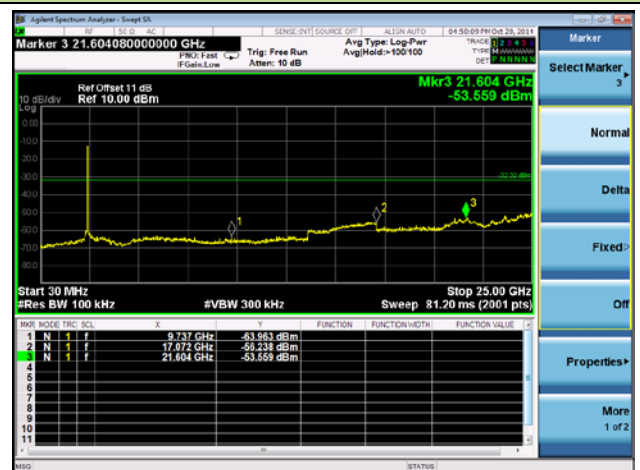

Channel 11 (2462MHz)

100kHz PSD reference Level

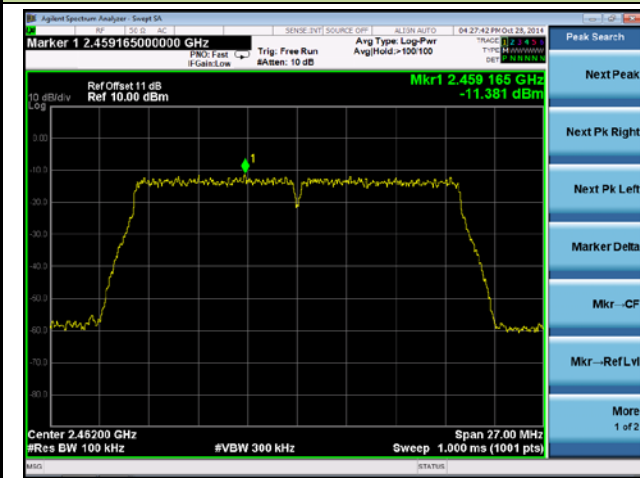

High Band Edge



Spurious Emission 30MHz ~ 25GHz

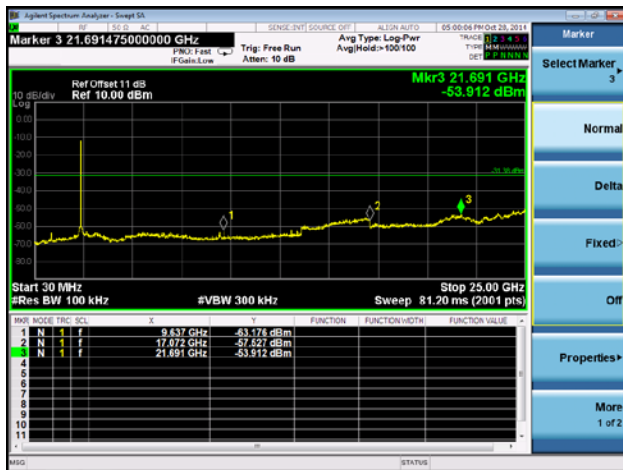

802.11n-HT40 Out-of-Band Emissions

Channel 03 (2422MHz)

100kHz PSD reference Level

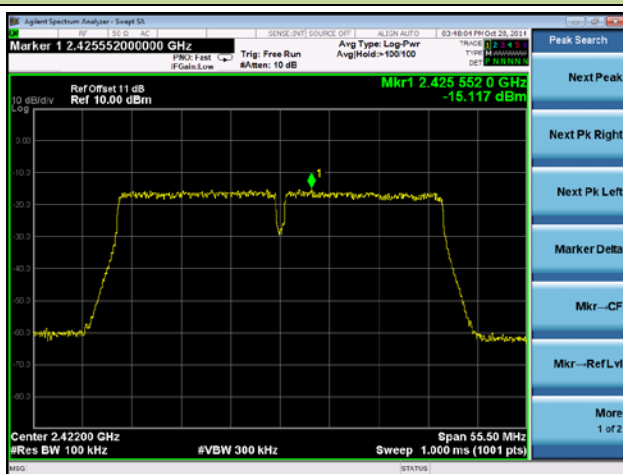

Low Band Edge

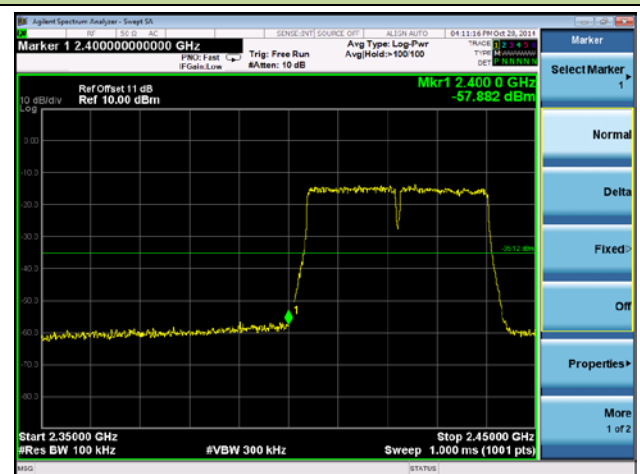

Spurious Emission 30MHz ~ 25GHz

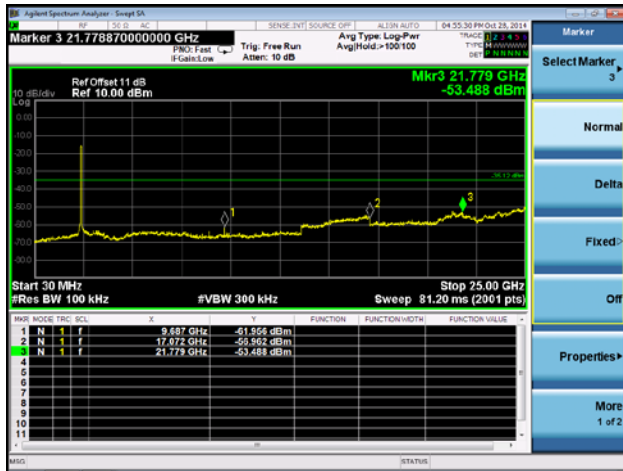

Channel 06 (2437MHz)

100kHz PSD reference Level

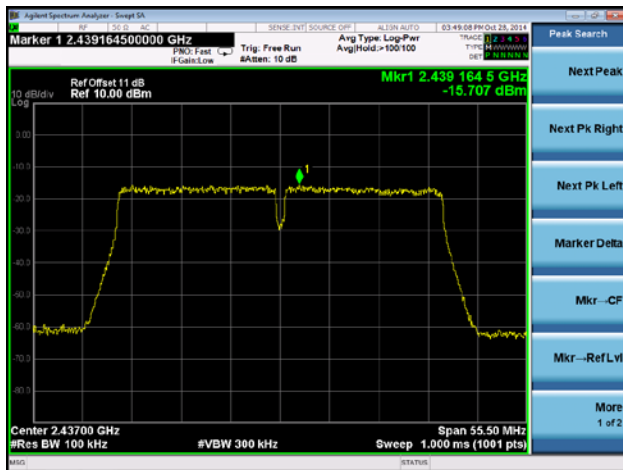

Spurious Emission 30MHz ~ 25GHz

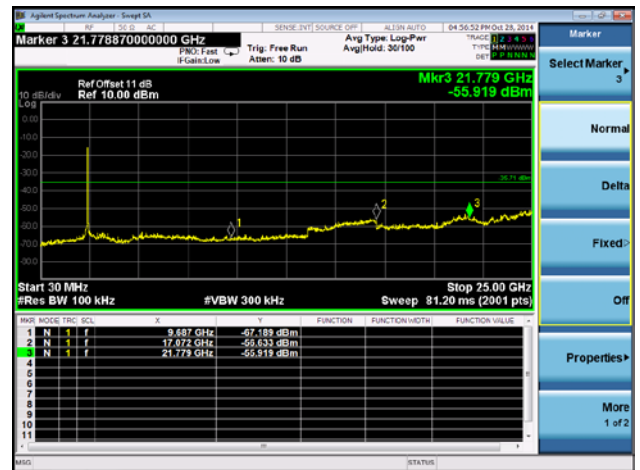

Channel 09 (2452MHz)

100kHz PSD reference Level

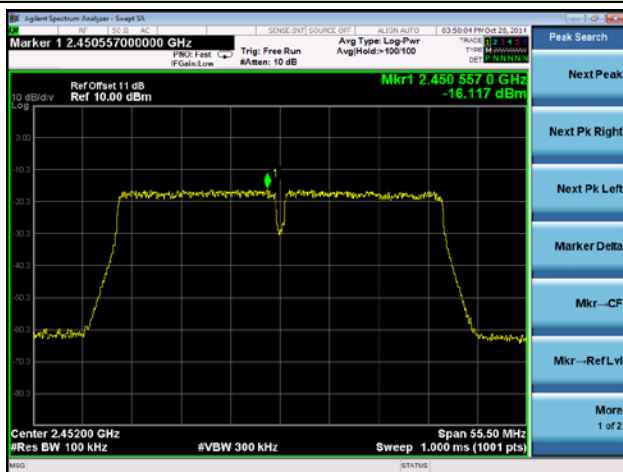

High Band Edge

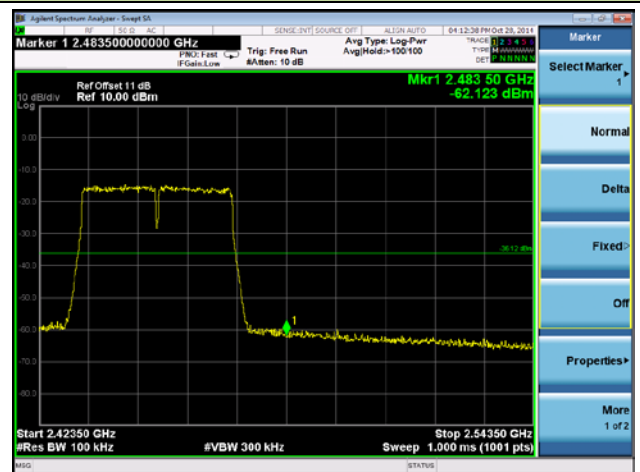

Spurious Emission 30MHz ~ 25GHz

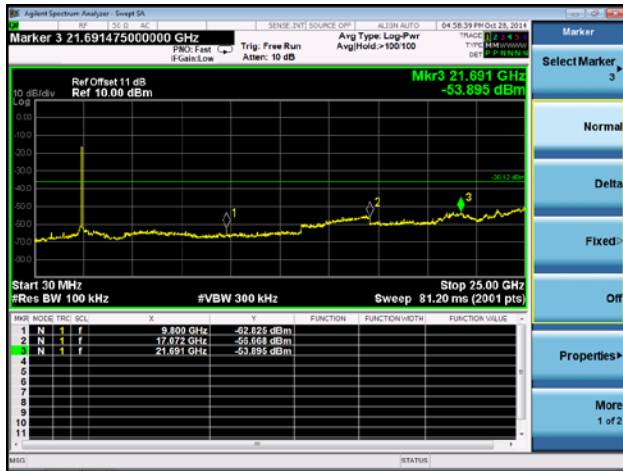

BLE Out-of-Band Emissions

Channel 00 (2402MHz)

100kHz PSD reference Level



Low Band Edge



Spurious Emission 30MHz ~ 25GHz

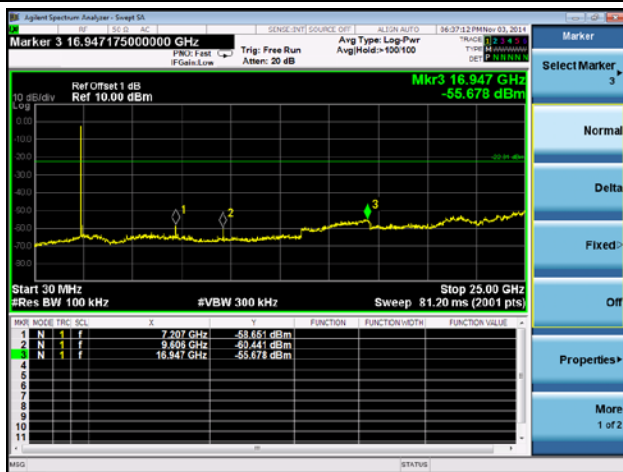

Channel 19 (2440MHz)

100kHz PSD reference Level

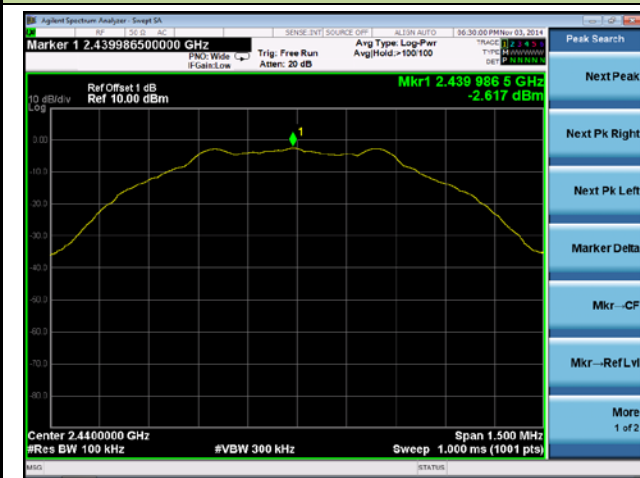

Spurious Emission 30MHz ~ 25GHz

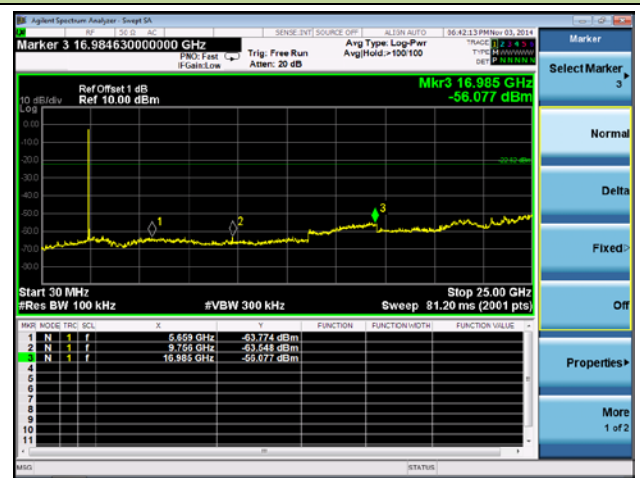

Channel 39 (2480MHz)

100kHz PSD reference Level

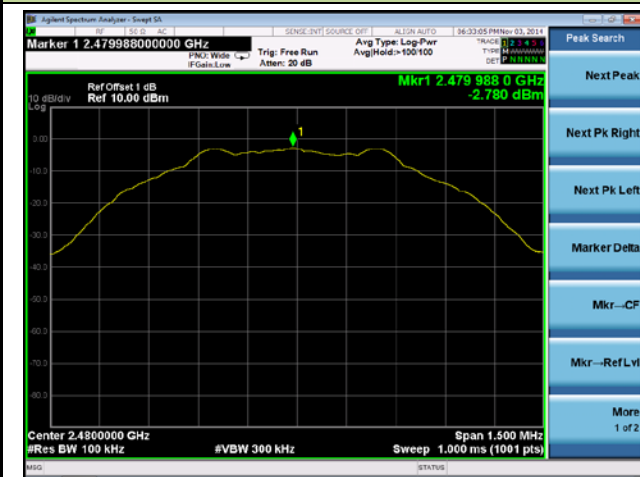

High Band Edge



Spurious Emission 30MHz ~ 25GHz

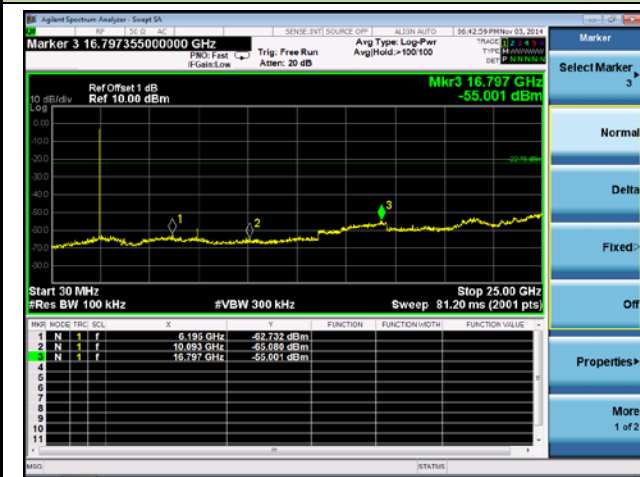

7.6. Radiated Spurious Emission Measurement

7.6.1. Test Limit

All out of band emissions appearing in a restricted band as specified in Section 15.205 of the Title 47 CFR must not exceed the limits shown in Table per Section 15.209.

FCC Part 15 Subpart C Paragraph 15.209		
Frequency [MHz]	Field Strength [V/m]	Measured Distance [Meters]
0.009 - 0.490	2400/F (kHz)	300
0.490 - 1.705	24000/F (kHz)	30
1.705 - 30	30	30
30 - 88	100	3
88 - 216	150	3
216 - 960	200	3
Above 960	500	3

7.6.2. Test Procedure Used

KDB 558074 D01v03r02 - Section 12.2.3 (quasi-peak measurements)

KDB 558074 D01v03r02 - Section 12.2.4 (peak power measurements)

KDB 558074 D01v03r02 - Section 12.2.5 (average power measurements)

7.6.3. Test Setting

Peak Field Strength Measurements per Section 12.2.4 of KDB 558074 D01v03r02

1. Analyzer center frequency was set to the frequency of the radiated spurious emission of interest
2. RBW = as specified in Table 1
3. VBW = 3MHz
4. Detector = peak
5. Sweep time = auto couple

6. Trace mode = max hold
7. Trace was allowed to stabilize

Table 1 - RBW as a function of frequency

Frequency	RBW
9 ~ 150 kHz	200 ~ 300 Hz
0.15 ~ 30 MHz	9 ~ 10 kHz
30 ~ 1000 MHz	100 ~ 120 kHz
> 1000 MHz	1 MHz

Average Field Strength Measurements per Section 12.2.5.1 of KDB 558074 D01v03r02

1. Analyzer center frequency was set to the frequency of the radiated spurious emission of interest
2. RBW = 1MHz
3. VBW \geq 1/T
4. De As an alternative, the instrument may be set to linear detector mode. Ensure that video filtering is applied in linear voltage domain (rather than in a log or dB domain). Some instruments require linear display mode in order to accomplish this. Others have a setting for Average-VBW Type, which can be set to "Voltage" regardless of the display mode
5. Detector = Peak
6. Sweep time = auto
7. Trace mode = max hold
8. Allow max hold to run for at least 50 times (1/duty cycle) traces

7.6.4. Test Setup

9kHz ~ 30MHz Test Setup:

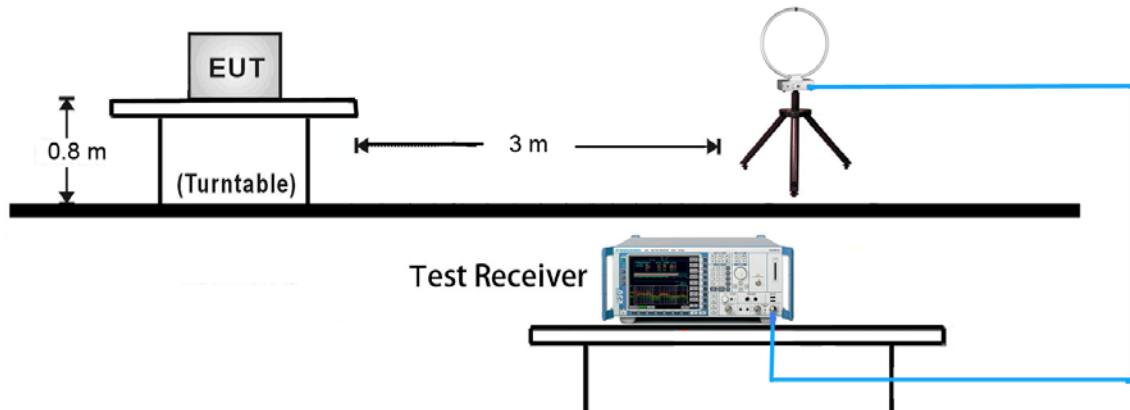

30MHz ~ 1GHz Test Setup:

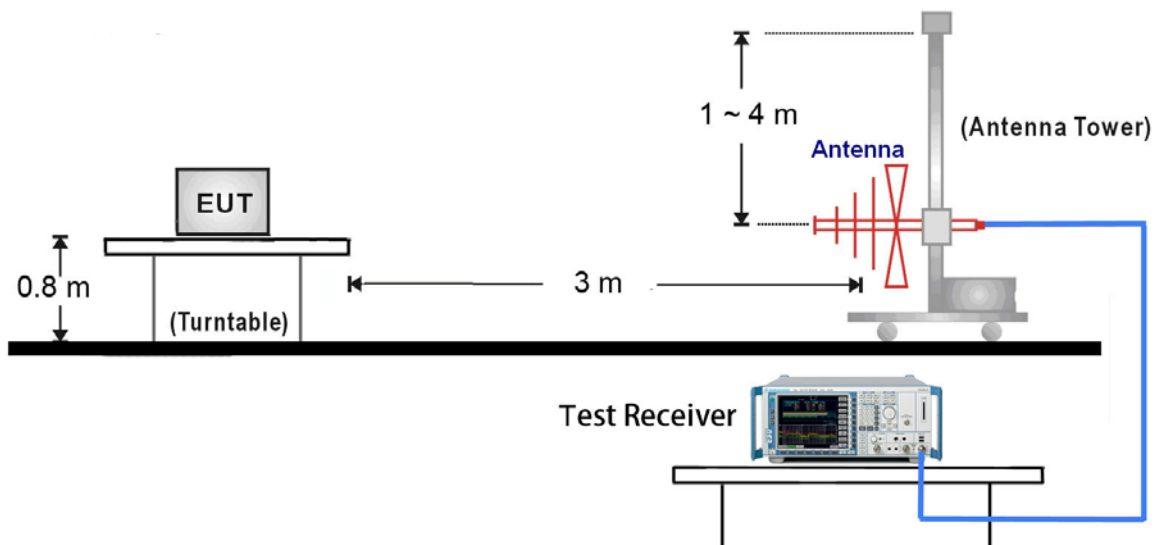

1GHz ~ 25GHz Test Setup:

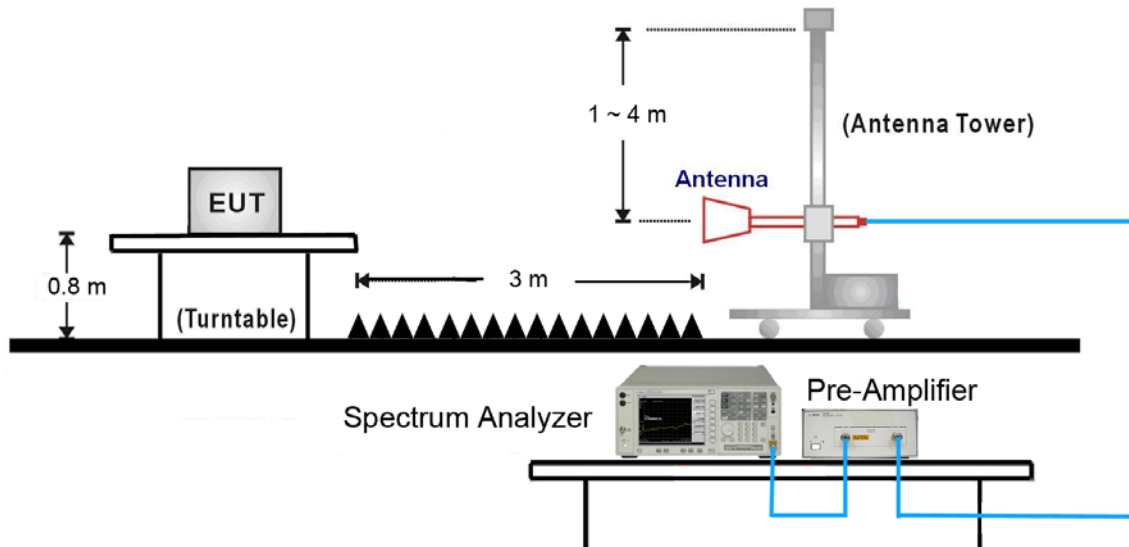

7.6.5. Test Result

Test Mode:	802.11b	Test Site:	AC1
Test Channel:	11	Test Engineer:	Roy Cheng
Remark:	1. Average measurement was not performed if peak level lower than average limit. 2. The worst case of Radiated Spurious Emission. 3. Other frequency was 20dB below limit line within 1-18GHz, there is not show in the report.		

Mark	Frequency (MHz)	Reading Level (dBμV)	Factor (dB)	Measure Level (dBμV/m)	Limit (dBμV/m)	Margin (dB)	Detector	Polarization
*	3045.0	37.0	3.4	40.4	71.8	-31.4	Peak	Horizontal
*	3412.0	36.5	3.3	39.8	71.8	-32.0	Peak	Horizontal
	4924.0	37.2	6.7	43.9	74.0	-30.1	Peak	Horizontal
	7386.0	35.4	14.1	49.5	74.0	-24.5	Peak	Horizontal
*	3145.0	36.8	3.6	40.4	71.8	-31.4	Peak	Vertical
*	3513.0	36.9	3.9	40.8	71.8	-31.0	Peak	Vertical
	4924.0	38.8	6.7	45.5	74.0	-28.5	Peak	Vertical
	7386.0	35.2	14.1	49.3	74.0	-24.7	Peak	Vertical

Note 1: "*" is not in restricted band, its limit is 20dBc of the fundamental emission level (91.8dBμV/m).

Note 2: Measure Level (dBμV/m) = Reading Level (dBμV) + Factor (dB)

Factor (dB) = Cable Loss (dB) + Antenna Factor (dB/m) - Pre_Amplifier Gain (dB)

Test Mode:	BLE	Test Site:	AC1
Test Channel:	00	Test Engineer:	Roy Cheng
Remark:	1. Average measurement was not performed if peak level lower than average limit. 2. The worst case of Radiated Spurious Emission. 3. Other frequency was 20dB below limit line within 1-18GHz, there is not show in the report.		

Mark	Frequency (MHz)	Reading Level (dBμV)	Factor (dB)	Measure Level (dBμV/m)	Limit (dBμV/m)	Margin (dB)	Detector	Polarization
*	3565.0	36.6	4.1	40.7	62.9	-22.2	Peak	Horizontal
*	4479.0	38.0	5.6	43.6	62.9	-19.3	Peak	Horizontal
	4804.0	37.6	6.4	44.0	74.0	-30.0	Peak	Horizontal
	7206.0	34.2	13.6	47.8	74.0	-26.2	Peak	Horizontal
*	3123.0	36.6	3.5	40.1	62.9	-22.8	Peak	Vertical
*	4415.0	37.7	5.5	43.2	62.9	-19.7	Peak	Vertical
	4804.0	34.8	6.4	41.2	74.0	-32.8	Peak	Vertical
	7206.0	35.3	13.6	48.9	74.0	-25.1	Peak	Vertical

Note 1: "*" is not in restricted band, its limit is 20dBc of the fundamental emission level (82.9dBμV/m).

Note 2: Measure Level (dBμV/m) = Reading Level (dBμV) + Factor (dB)

Factor (dB) = Cable Loss (dB) + Antenna Factor (dB/m) - Pre_Amplifier Gain (dB)

The worst case of Radiated Emission below 1GHz:

Engineer: Milo Li	
Site: AC1	Time: 2014/10/27 - 10:03
Limit: FCC_Part15.209_RE(3m)	Margin: 0
Probe: VULB9162_0.03-8GHz	Polarity: Horizontal
EUT: 8 Inch Tablet	Power: AC 120V/60Hz
Worst Case Mode: 802.11b at channel 2412MHz	

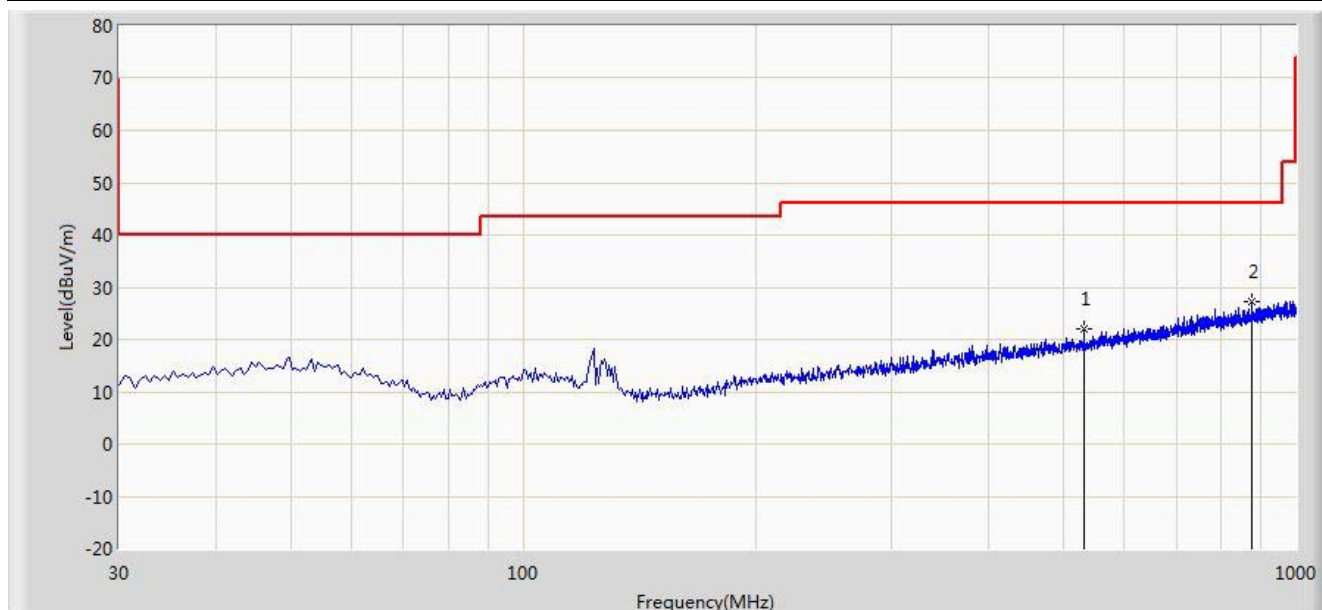

No	Flag	Mark	Frequency (MHz)	Measure Level (dBuV/m)	Reading Level (dBuV)	Over Limit (dB)	Limit (dBuV/m)	Factor (dB)	Type
1			532.460	21.919	3.709	-24.081	46.000	18.210	QP
2		*	877.780	27.225	4.077	-18.775	46.000	23.148	QP

Note: Measure Level (dB μ V/m) = Reading Level (dB μ V) + Factor (dB)

Factor (dB) = Cable Loss (dB) + Antenna Factor (dB/m)

Engineer: Milo Li	
Site: AC1	Time: 2014/10/27 - 10:05
Limit: FCC_Part15.209_RE(3m)	Margin: 0
Probe: VULB9162_0.03-8GHz	Polarity: Vertical
EUT: 8 Inch Tablet	Power: AC 120V/60Hz
Worst Case Mode: 802.11b at channel 2412MHz	

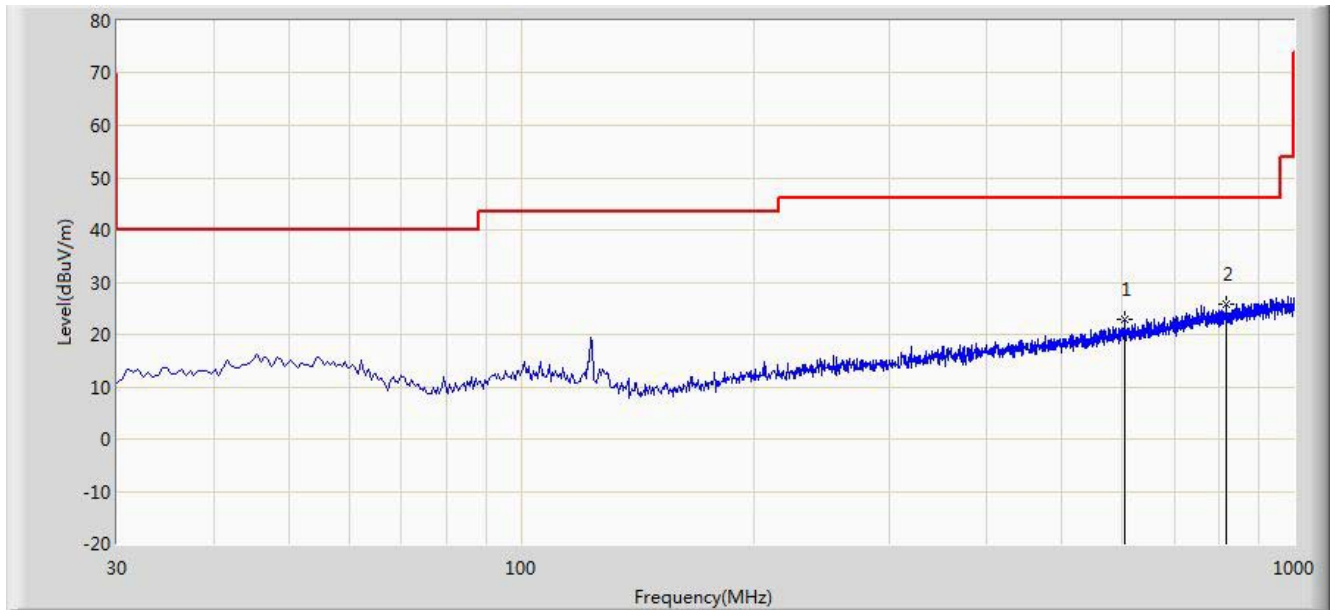

No	Flag	Mark	Frequency (MHz)	Measure Level (dBuV/m)	Reading Level (dBuV)	Over Limit (dB)	Limit (dBuV/m)	Factor (dB)	Type
1			604.725	22.802	3.305	-23.198	46.000	19.497	QP
2		*	817.155	25.842	3.449	-20.158	46.000	22.393	QP

Note: Measure Level (dBuV/m) = Reading Level (dBuV) + Factor (dB)

Factor (dB) = Cable Loss (dB) + Antenna Factor (dB/m)

Engineer: Roy Cheng	
Site: AC1	Time: 2014/10/29 - 16:39
Limit: FCC_Part15.209_RE(3m)	Margin: 0
Probe: FMZB1519_0.009-30MHz	Polarity: Face On
EUT: 8 Inch Tablet	Power: AC 120V/60Hz
Note: There is the ambient noise within frequency range 9kHz~30MHz.	

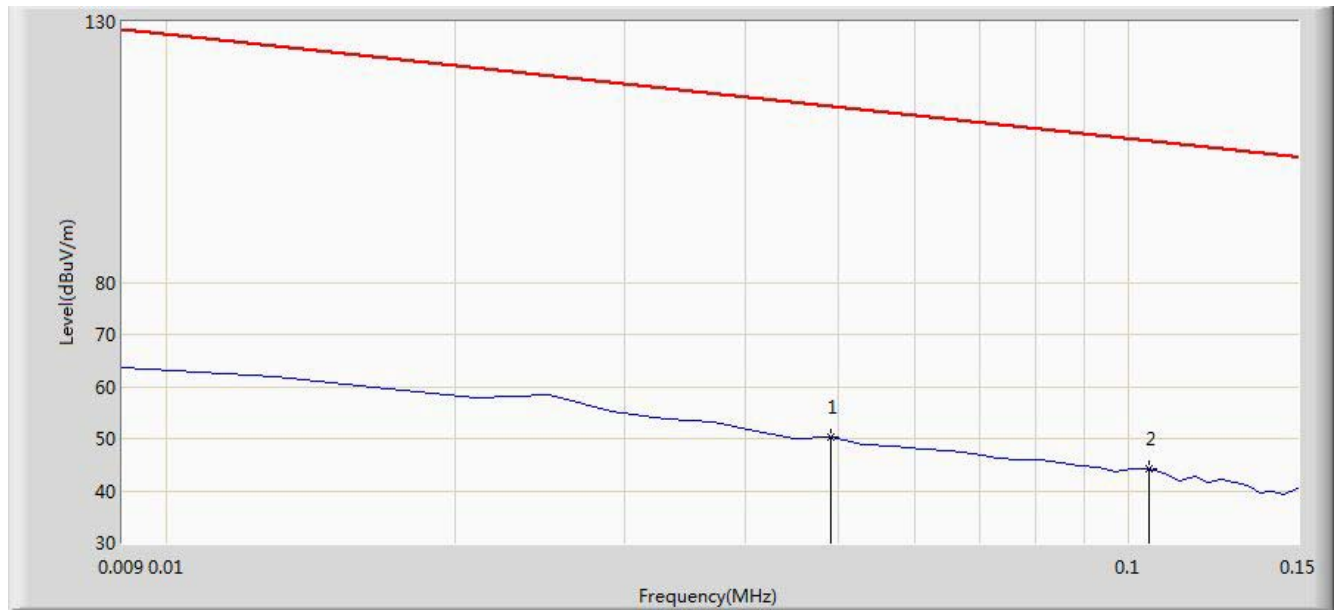

No	Flag	Mark	Frequency (MHz)	Measure Level (dBuV/m)	Reading Level (dBuV)	Over Limit (dB)	Limit (dBuV/m)	Factor (dB)	Type
1			0.049	50.367	29.861	-63.422	113.789	20.505	QP
2		*	0.105	44.143	23.996	-63.029	107.173	20.147	QP

Note: Measure Level (dBμV/m) = Reading Level (dBμV) + Factor (dB)

Factor (dB) = Cable Loss (dB) + Antenna Factor (dB/m)

Engineer: Roy Cheng	
Site: AC1	Time: 2014/10/29 - 16:41
Limit: FCC_Part15.209_RE(3m)	Margin: 0
Probe: FMZB1519_0.009-30MHz	Polarity: Face On
EUT: 8 Inch Tablet	Power: AC 120V/60Hz
Note: There is the ambient noise within frequency range 9kHz~30MHz.	

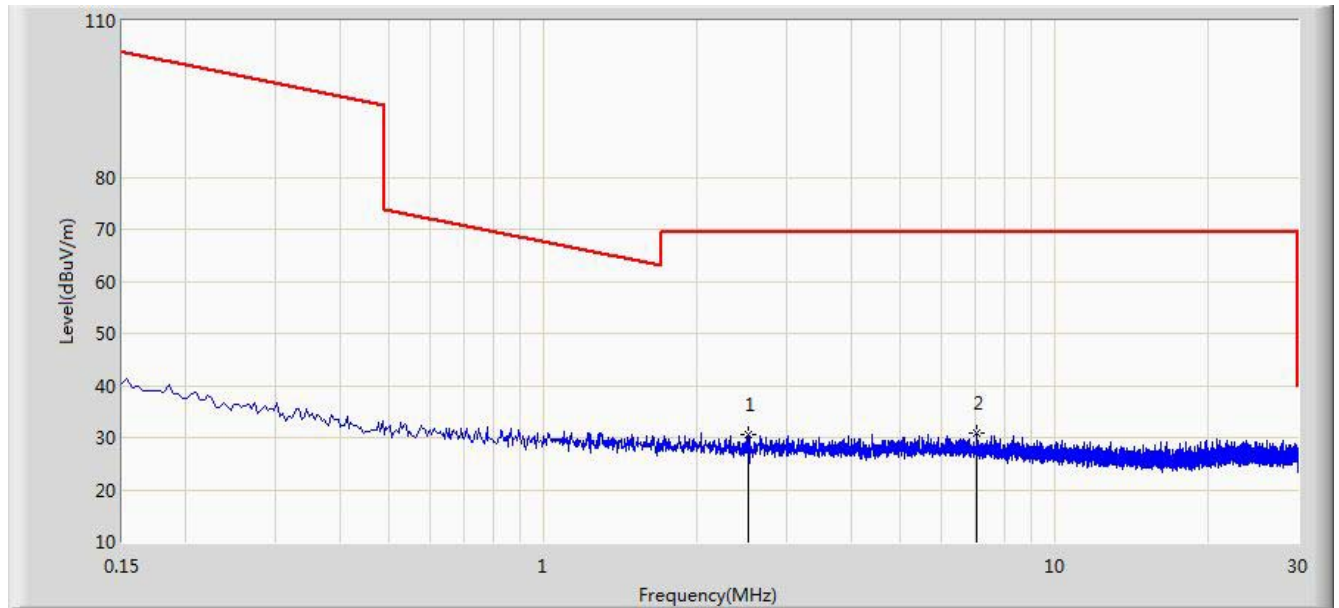

No	Flag	Mark	Frequency (MHz)	Measure Level (dBuV/m)	Reading Level (dBuV)	Over Limit (dB)	Limit (dBuV/m)	Factor (dB)	Type
1			2.513	30.495	10.336	-39.005	69.500	20.159	QP
2		*	7.041	30.974	10.579	-38.526	69.500	20.395	QP

Note: Measure Level (dBμV/m) = Reading Level (dBμV) + Factor (dB)

Factor (dB) = Cable Loss (dB) + Antenna Factor (dB/m)

Engineer: Roy Cheng	
Site: AC1	Time: 2014/10/29 - 17:39
Limit: FCC_Part15.209_RE(3m)	Margin: 0
Probe: BBHA9170_18-40GHz	Polarity: Horizontal
EUT: 8 Inch Tablet	Power: AC 120V/60Hz
Note: There is the ambient noise within frequency range 18 ~ 25GHz.	

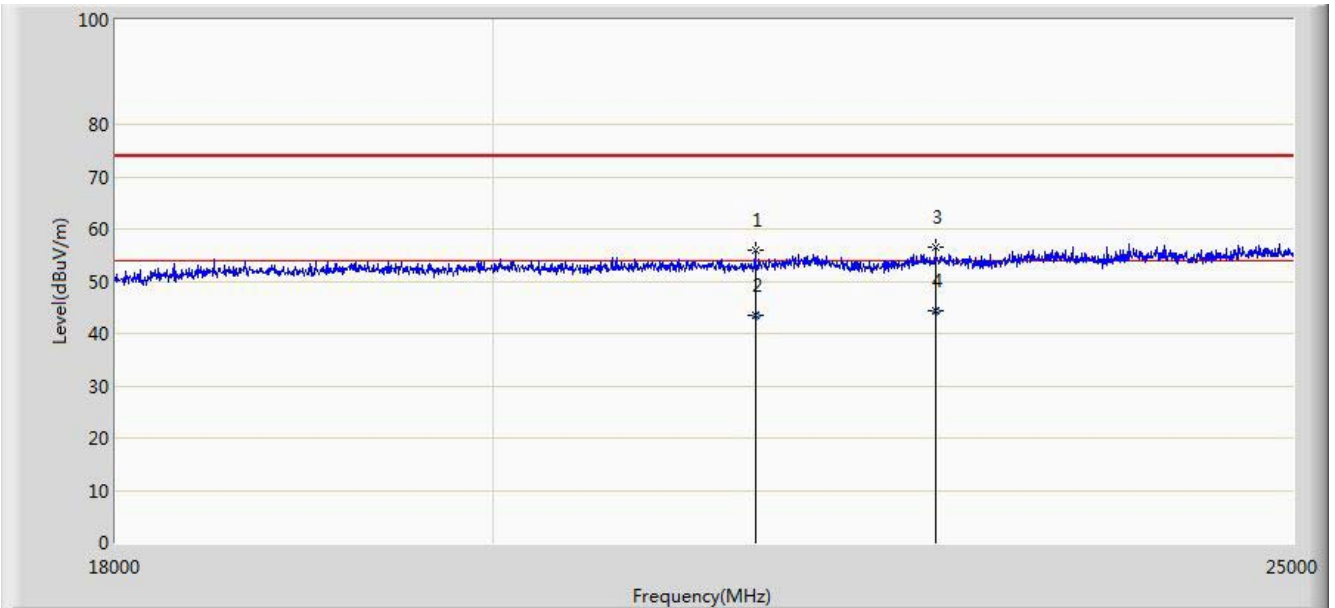

No	Flag	Mark	Frequency (MHz)	Measure Level (dBuV/m)	Reading Level (dBuV)	Over Limit (dB)	Limit (dBuV/m)	Factor (dB)	Type
1			21517.500	55.869	17.883	-18.131	74.000	37.986	PK
2			21517.650	43.351	5.365	-10.649	54.000	37.986	AV
3			22630.500	56.509	18.223	-17.491	74.000	38.286	PK
4		*	22630.540	44.310	6.024	-9.690	54.000	38.286	AV

Note: Measure Level (dBuV/m) = Reading Level (dBuV) + Factor (dB)

Factor (dB) = Cable Loss (dB) + Antenna Factor (dB/m)

Engineer: Roy Cheng	
Site: AC1	Time: 2014/10/29 - 17:43
Limit: FCC_Part15.209_RE(3m)	Margin: 0
Probe: BBHA9170_18-40GHz	Polarity: Vertical
EUT: 8 Inch Tablet	Power: AC 120V/60Hz
Note: There is the ambient noise within frequency range 18 ~ 25GHz.	

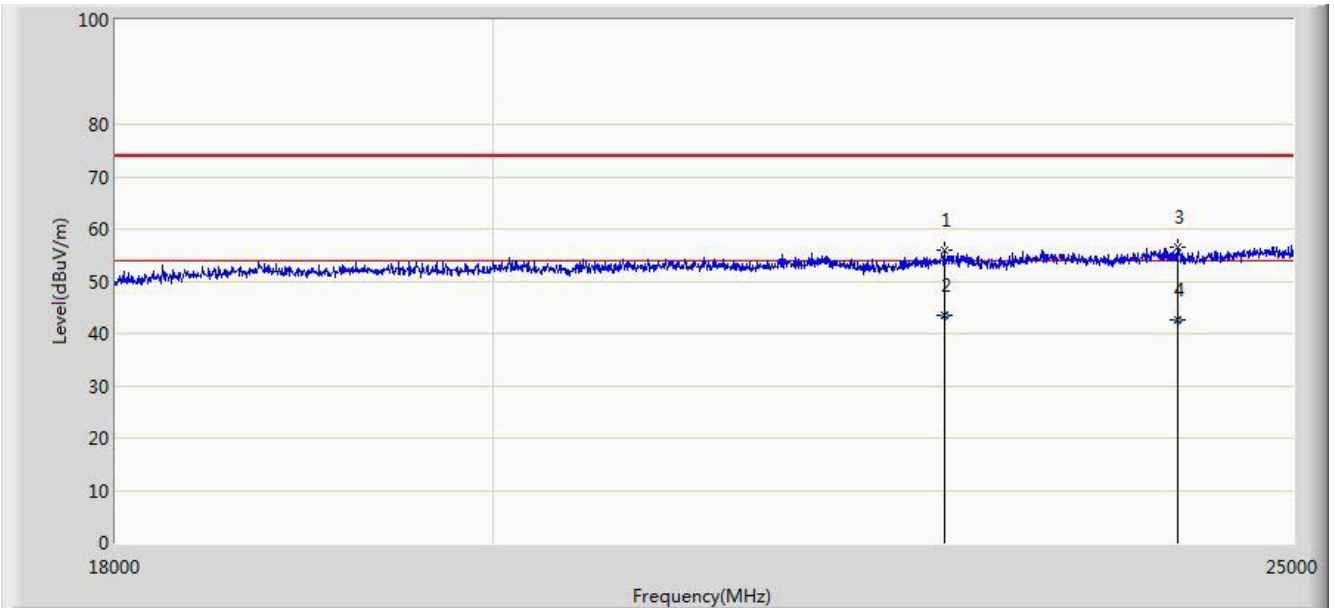

No	Flag	Mark	Frequency (MHz)	Measure Level (dBuV/m)	Reading Level (dBuV)	Over Limit (dB)	Limit (dBuV/m)	Factor (dB)	Type
1			22686.500	55.811	17.457	-18.189	74.000	38.354	PK
2		*	22686.540	43.598	5.244	-10.402	54.000	38.354	AV
3			24205.500	56.430	17.607	-17.570	74.000	38.823	PK
4			24205.658	42.518	3.695	-11.482	54.000	38.823	AV

Note: Measure Level (dBuV/m) = Reading Level (dBuV) + Factor (dB)

Factor (dB) = Cable Loss (dB) + Antenna Factor (dB/m)

7.7. Radiated Restricted Band Edge Measurement

7.7.1. Test Result

Engineer: Milo Li	
Site: AC1	Time: 2014/10/27 - 15:39
Limit: FCC_Part15.209_RE(3m)	Margin: 0
Probe: BBHA9120D_1-18GHz	Polarity: Horizontal
EUT: 8 Inch Tablet	Power: AC 120V/60Hz
Worst Case Mode: 802.11b at channel 2412MHz	

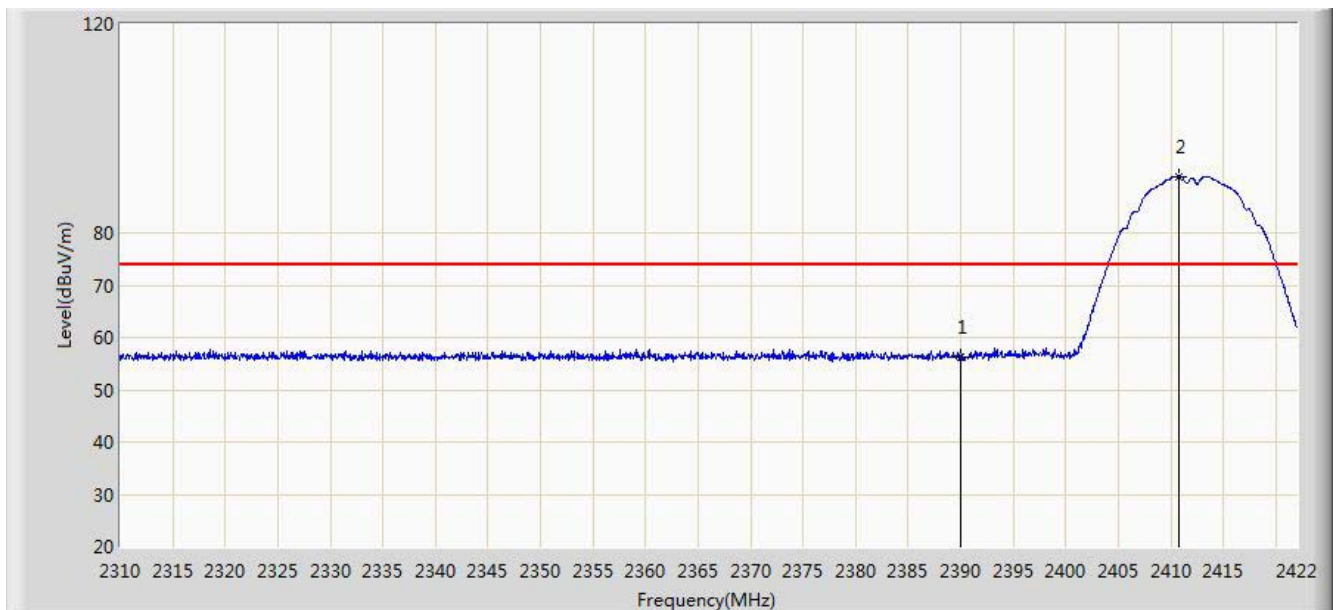

No	Flag	Mark	Frequency (MHz)	Measure Level (dBuV/m)	Reading Level (dBuV)	Over Limit (dB)	Limit (dBuV/m)	Factor (dB)	Type
1			2390.000	56.343	25.659	-17.657	74.000	30.684	PK
2		*	2410.800	90.850	60.203	N/A	N/A	30.647	PK

Note: Measure Level (dB μ V/m) = Reading Level (dB μ V) + Factor (dB)

Factor (dB) = Cable Loss (dB) + Antenna Factor (dB/m)

Engineer: Milo Li	
Site: AC1	Time: 2014/10/27 - 15:45
Limit: FCC_Part15.209_RE(3m)	Margin: 0
Probe: BBHA9120D_1-18GHz	Polarity: Horizontal
EUT: 8 Inch Tablet	Power: AC 120V/60Hz
Worst Case Mode: 802.11b at channel 2412MHz	

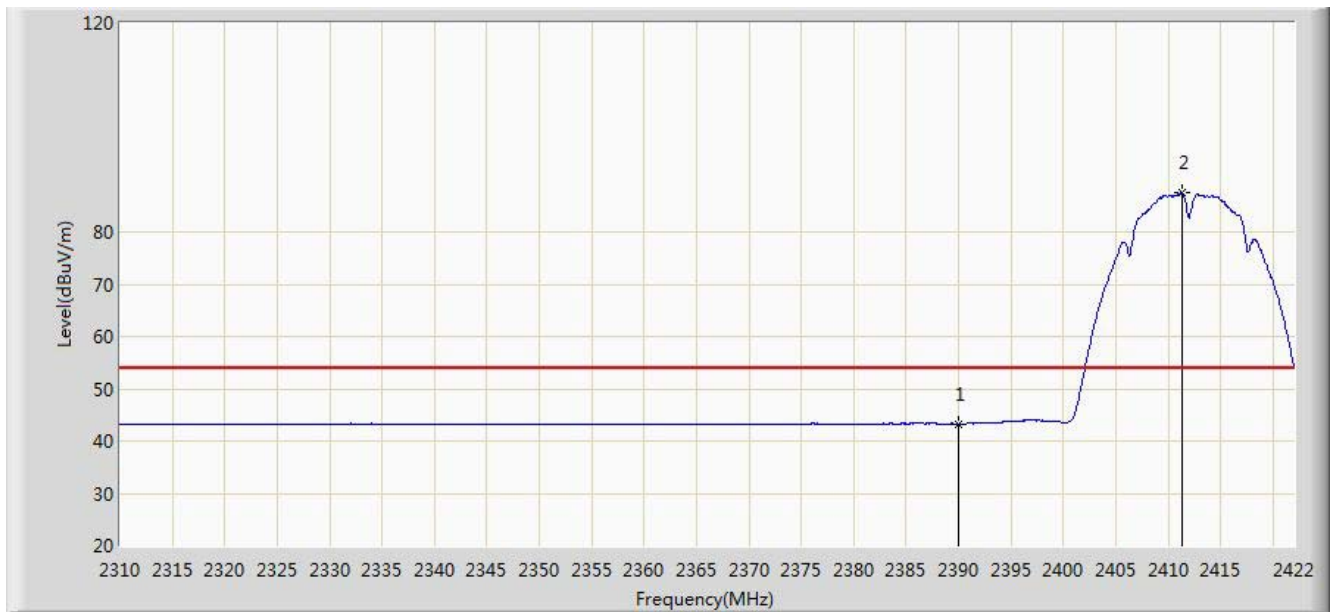

No	Flag	Mark	Frequency (MHz)	Measure Level (dBuV/m)	Reading Level (dBuV)	Over Limit (dB)	Limit (dBuV/m)	Factor (dB)	Type
1			2390.000	43.326	12.642	-10.674	54.000	30.684	AV
2		*	2411.304	87.420	56.774	N/A	N/A	30.646	AV

Note: Measure Level (dB μ V/m) = Reading Level (dB μ V) + Factor (dB)

Factor (dB) = Cable Loss (dB) + Antenna Factor (dB/m)

Engineer: Milo Li	
Site: AC1	Time: 2014/10/27 - 15:46
Limit: FCC_Part15.209_RE(3m)	Margin: 0
Probe: BBHA9120D_1-18GHz	Polarity: Vertical
EUT: 8 Inch Tablet	Power: AC 120V/60Hz
Worst Case Mode: 802.11b at channel 2412MHz	

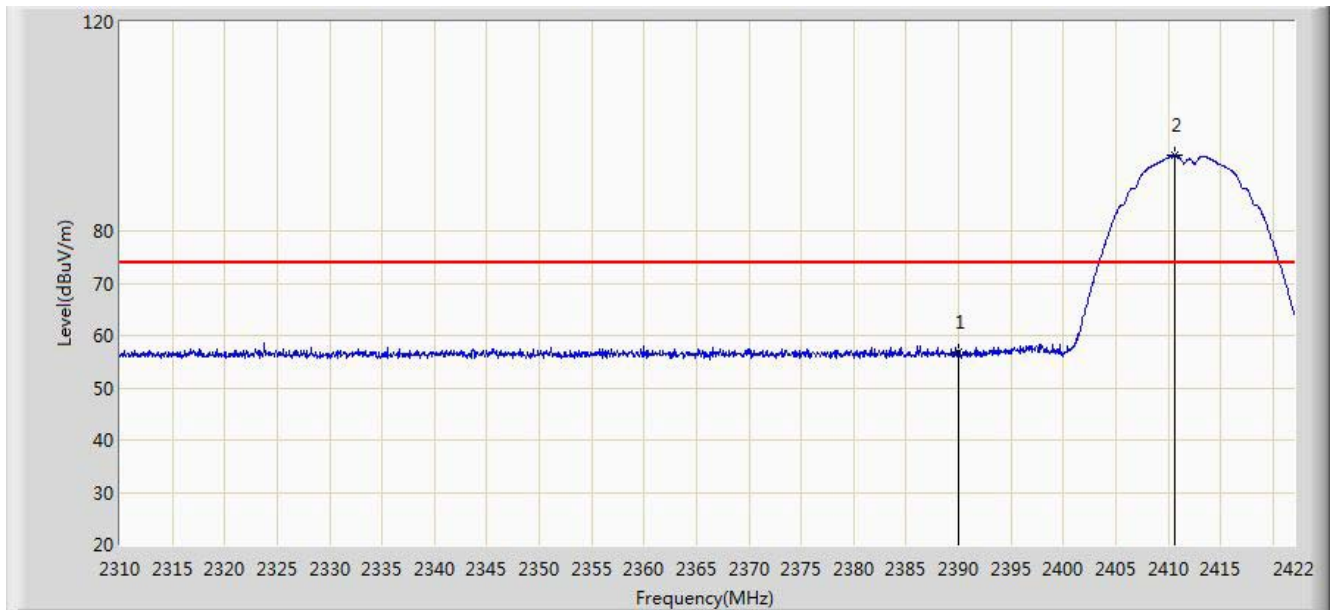

No	Flag	Mark	Frequency (MHz)	Measure Level (dBuV/m)	Reading Level (dBuV)	Over Limit (dB)	Limit (dBuV/m)	Factor (dB)	Type
1			2390.000	56.874	26.190	-17.126	74.000	30.684	PK
2		*	2410.632	94.387	63.740	N/A	N/A	30.647	PK

Note: Measure Level (dB μ V/m) = Reading Level (dB μ V) + Factor (dB)

Factor (dB) = Cable Loss (dB) + Antenna Factor (dB/m)

Engineer: Milo Li	
Site: AC1	Time: 2014/10/27 - 15:49
Limit: FCC_Part15.209_RE(3m)	Margin: 0
Probe: BBHA9120D_1-18GHz	Polarity: Vertical
EUT: 8 Inch Tablet	Power: AC 120V/60Hz
Worst Case Mode: 802.11b at channel 2412MHz	

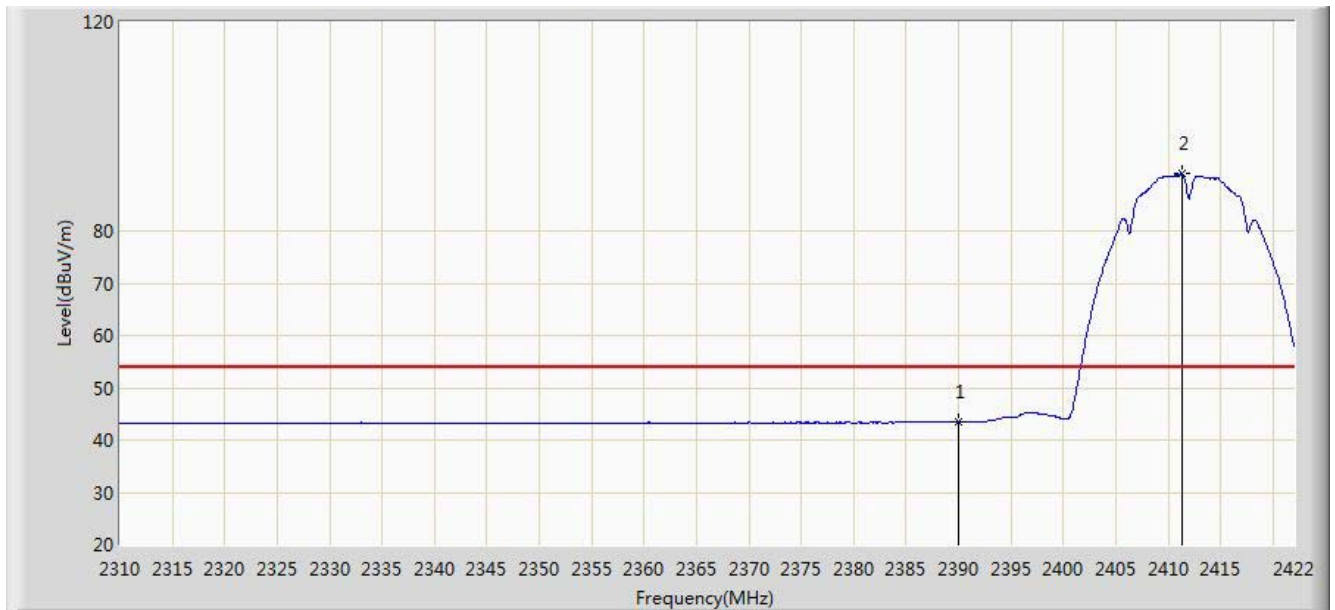

No	Flag	Mark	Frequency (MHz)	Measure Level (dBuV/m)	Reading Level (dBuV)	Over Limit (dB)	Limit (dBuV/m)	Factor (dB)	Type
1			2390.000	43.367	12.683	-10.633	54.000	30.684	AV
2		*	2411.304	90.877	60.231	N/A	N/A	30.646	AV

Note: Measure Level (dBμV/m) = Reading Level (dBμV) + Factor (dB)

Factor (dB) = Cable Loss (dB) + Antenna Factor (dB/m)

Engineer: Milo Li	
Site: AC1	Time: 2014/10/27 - 15:16
Limit: FCC_Part15.209_RE(3m)	Margin: 0
Probe: BBHA9120D_1-18GHz	Polarity: Horizontal
EUT: 8 Inch Tablet	Power: AC 120V/60Hz
Worst Case Mode: 802.11n-HT40 at channel 2452MHz	



No	Flag	Mark	Frequency (MHz)	Measure Level (dBuV/m)	Reading Level (dBuV)	Over Limit (dB)	Limit (dBuV/m)	Factor (dB)	Type
1		*	2442.166	87.560	56.965	N/A	N/A	30.595	PK
2			2483.500	56.834	26.161	-17.166	74.000	30.673	PK

Note: Measure Level (dB μ V/m) = Reading Level (dB μ V) + Factor (dB)

Factor (dB) = Cable Loss (dB) + Antenna Factor (dB/m)

Engineer: Milo Li	
Site: AC1	Time: 2014/10/27 - 15:21
Limit: FCC_Part15.209_RE(3m)	Margin: 0
Probe: BBHA9120D_1-18GHz	Polarity: Horizontal
EUT: 8 Inch Tablet	Power: AC 120V/60Hz
Worst Case Mode: 802.11n-HT40 at channel 2452MHz	

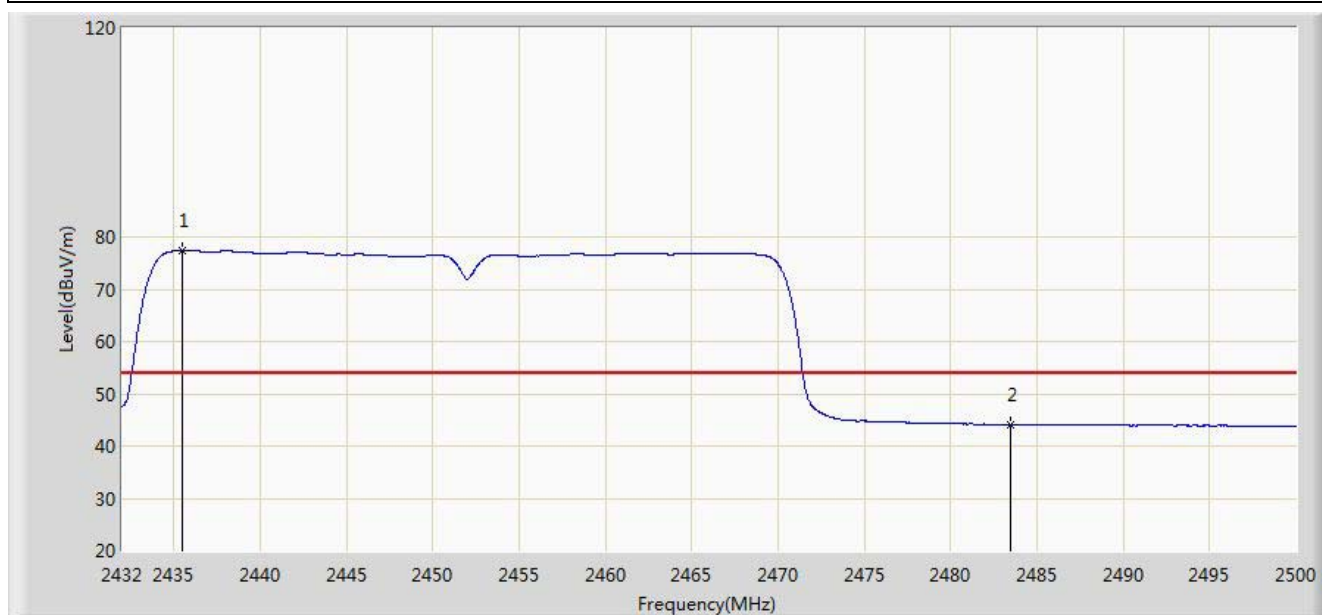

No	Flag	Mark	Frequency (MHz)	Measure Level (dBuV/m)	Reading Level (dBuV)	Over Limit (dB)	Limit (dBuV/m)	Factor (dB)	Type
1		*	2435.468	77.389	46.782	N/A	N/A	30.607	AV
2			2483.500	44.137	13.464	-9.863	54.000	30.673	AV

Note: Measure Level (dB μ V/m) = Reading Level (dB μ V) + Factor (dB)

Factor (dB) = Cable Loss (dB) + Antenna Factor (dB/m)

Engineer: Milo Li	
Site: AC1	Time: 2014/10/27 - 15:22
Limit: FCC_Part15.209_RE(3m)	Margin: 0
Probe: BBHA9120D_1-18GHz	Polarity: Vertical
EUT: 8 Inch Tablet	Power: AC 120V/60Hz
Worst Case Mode: 802.11n-HT40 at channel 2452MHz	

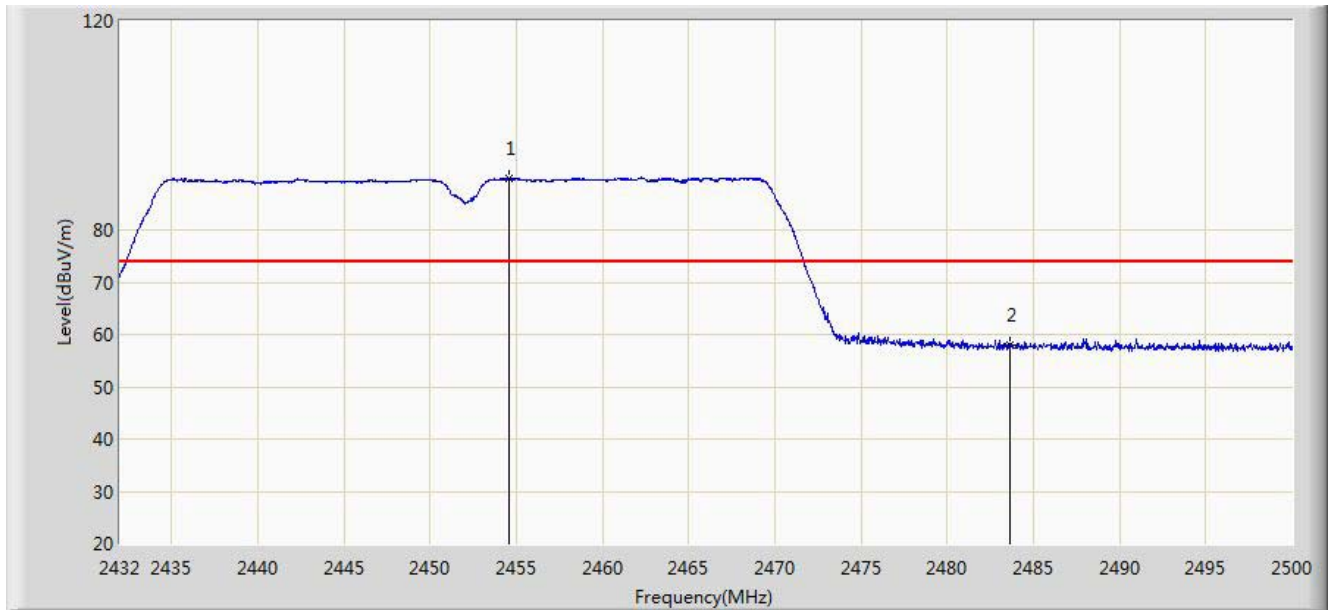

No	Flag	Mark	Frequency (MHz)	Measure Level (dBuV/m)	Reading Level (dBuV)	Over Limit (dB)	Limit (dBuV/m)	Factor (dB)	Type
1		*	2454.610	89.762	59.162	N/A	N/A	30.601	PK
2			2483.600	57.908	27.235	-16.092	74.000	30.673	PK

Note: Measure Level (dBμV/m) = Reading Level (dBμV) + Factor (dB)

Factor (dB) = Cable Loss (dB) + Antenna Factor (dB/m)

Engineer: Milo Li	
Site: AC1	Time: 2014/10/27 - 15:37
Limit: FCC_Part15.209_RE(3m)	Margin: 0
Probe: BBHA9120D_1-18GHz	Polarity: Vertical
EUT: 8 Inch Tablet	Power: AC 120V/60Hz
Worst Case Mode: 802.11n-HT40 at channel 2452MHz	

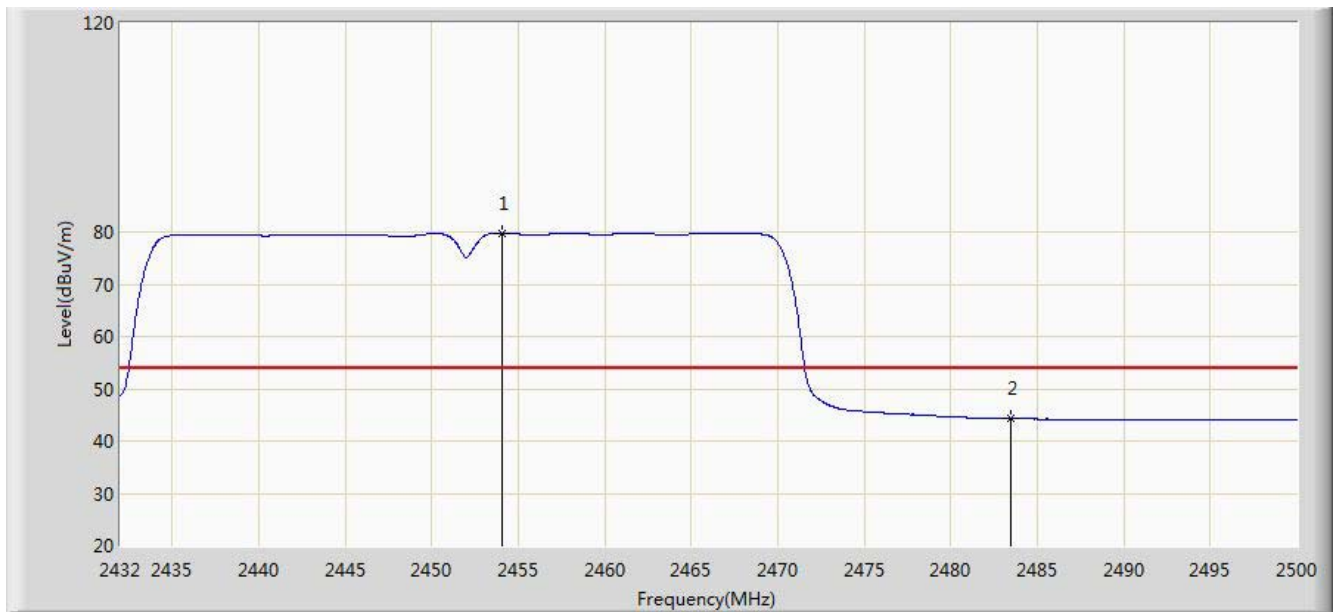

No	Flag	Mark	Frequency (MHz)	Measure Level (dBuV/m)	Reading Level (dBuV)	Over Limit (dB)	Limit (dBuV/m)	Factor (dB)	Type
1		*	2454.066	79.844	49.244	N/A	N/A	30.599	AV
2			2483.500	44.348	13.675	-9.652	54.000	30.673	AV

Note: Measure Level (dBμV/m) = Reading Level (dBμV) + Factor (dB)

Factor (dB) = Cable Loss (dB) + Antenna Factor (dB/m)

Engineer: Milo Li	
Site: AC1	Time: 2014/11/03 - 19:32
Limit: FCC_Part15.209_RE(3m)	Margin: 0
Probe: BBHA9120D_1-18GHz	Polarity: Horizontal
EUT: 8 Inch Tablet	Power: AC 120V/60Hz
Test Mode: BLE at channel 2402MHz	

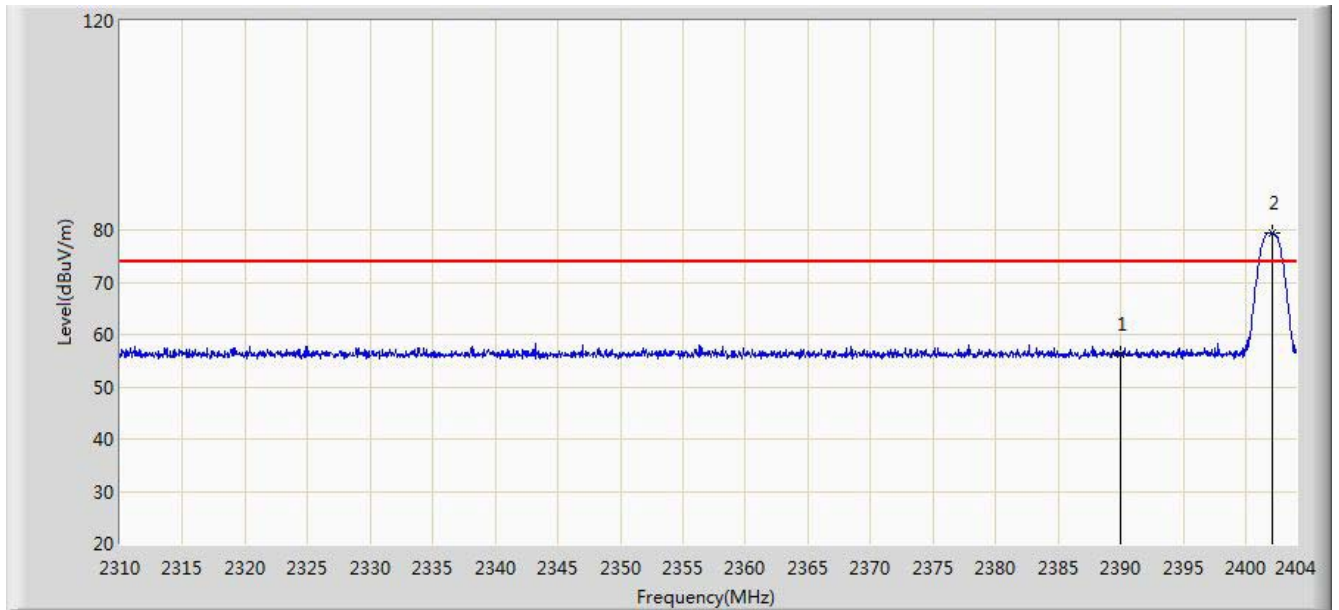

No	Flag	Mark	Frequency (MHz)	Measure Level (dBuV/m)	Reading Level (dBuV)	Over Limit (dB)	Limit (dBuV/m)	Factor (dB)	Type
1			2390.000	56.246	25.562	-17.754	74.000	30.684	PK
2		*	2402.073	79.390	48.729	N/A	N/A	30.661	PK

Note: Measure Level (dBμV/m) = Reading Level (dBμV) + Factor (dB)

Factor (dB) = Cable Loss (dB) + Antenna Factor (dB/m)

Engineer: Milo Li	
Site: AC1	Time: 2014/11/03 - 19:37
Limit: FCC_Part15.209_RE(3m)	Margin: 0
Probe: BBHA9120D_1-18GHz	Polarity: Horizontal
EUT: 8 Inch Tablet	Power: AC 120V/60Hz
Test Mode: BLE at channel 2402MHz	

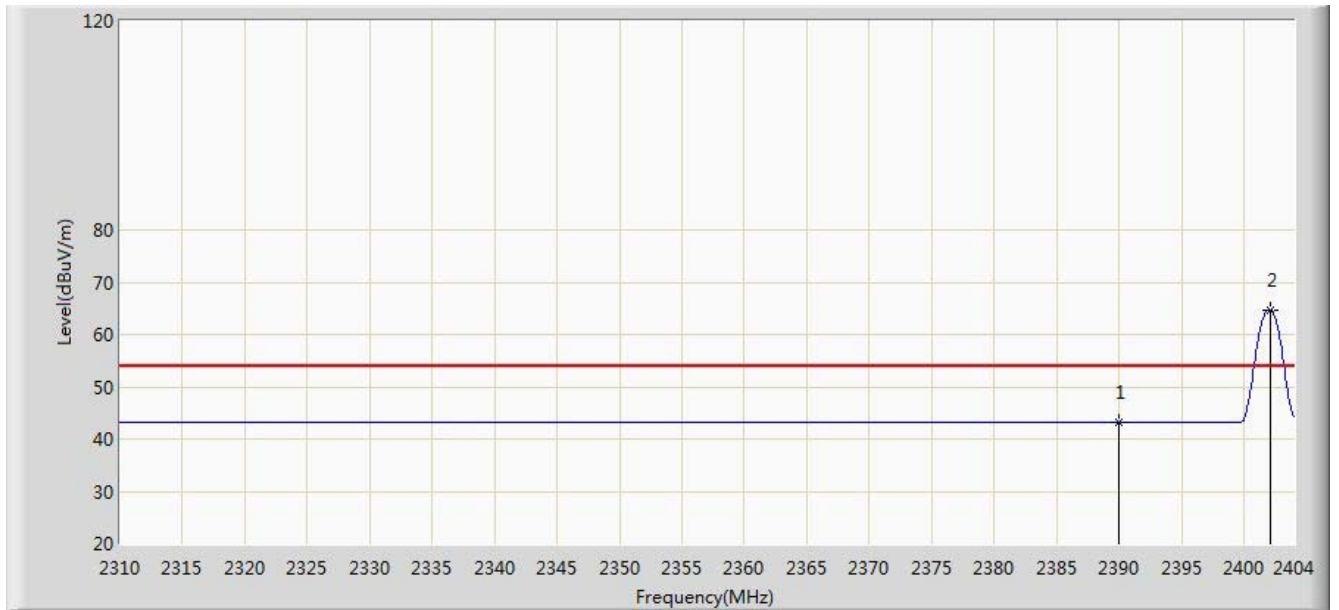

No	Flag	Mark	Frequency (MHz)	Measure Level (dBuV/m)	Reading Level (dBuV)	Over Limit (dB)	Limit (dBuV/m)	Factor (dB)	Type
1			2390.000	43.170	12.486	-10.830	54.000	30.684	AV
2		*	2402.073	64.708	34.047	N/A	N/A	30.661	AV

Note: Measure Level (dBμV/m) = Reading Level (dBμV) + Factor (dB)

Factor (dB) = Cable Loss (dB) + Antenna Factor (dB/m)

Engineer: Milo Li	
Site: AC1	Time: 2014/11/03 - 19:37
Limit: FCC_Part15.209_RE(3m)	Margin: 0
Probe: BBHA9120D_1-18GHz	Polarity: Vertical
EUT: 8 Inch Tablet	Power: AC 120V/60Hz
Test Mode: BLE at channel 2402MHz	

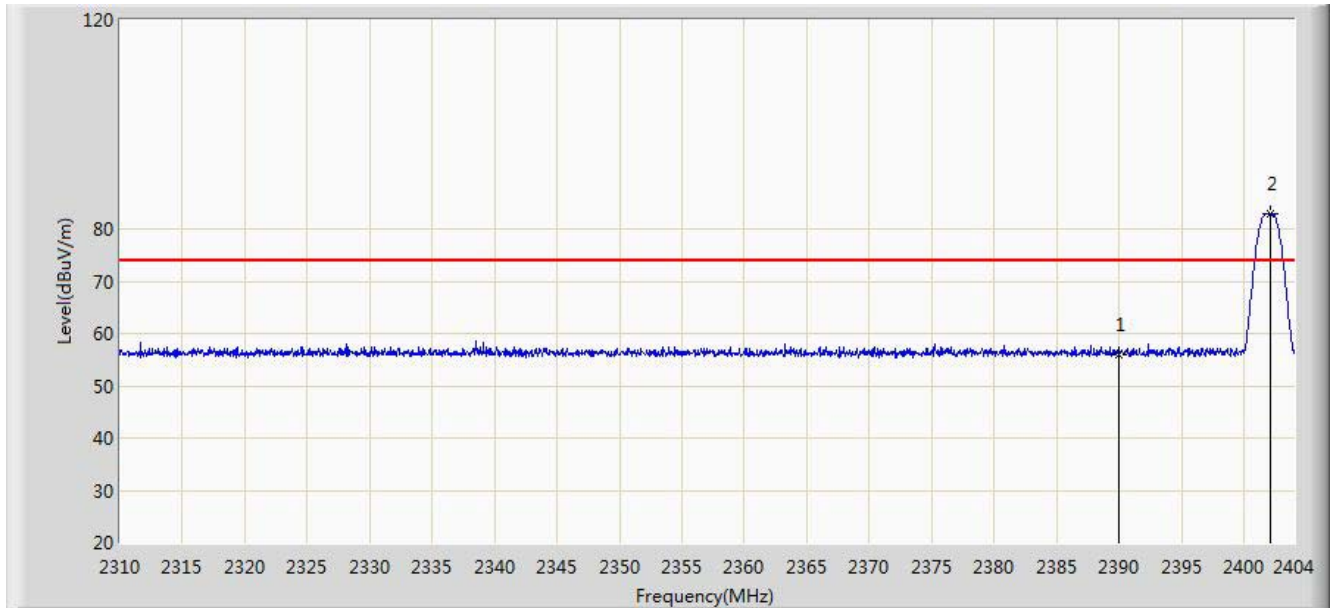

No	Flag	Mark	Frequency (MHz)	Measure Level (dBuV/m)	Reading Level (dBuV)	Over Limit (dB)	Limit (dBuV/m)	Factor (dB)	Type
1			2390.000	56.040	25.356	-17.960	74.000	30.684	PK
2		*	2402.073	82.938	52.277	N/A	N/A	30.661	PK

Note: Measure Level (dBμV/m) = Reading Level (dBμV) + Factor (dB)

Factor (dB) = Cable Loss (dB) + Antenna Factor (dB/m)

Engineer: Milo Li	
Site: AC1	Time: 2014/11/03 - 19:40
Limit: FCC_Part15.209_RE(3m)	Margin: 0
Probe: BBHA9120D_1-18GHz	Polarity: Vertical
EUT: 8 Inch Tablet	Power: AC 120V/60Hz
Test Mode: BLE at channel 2402MHz	

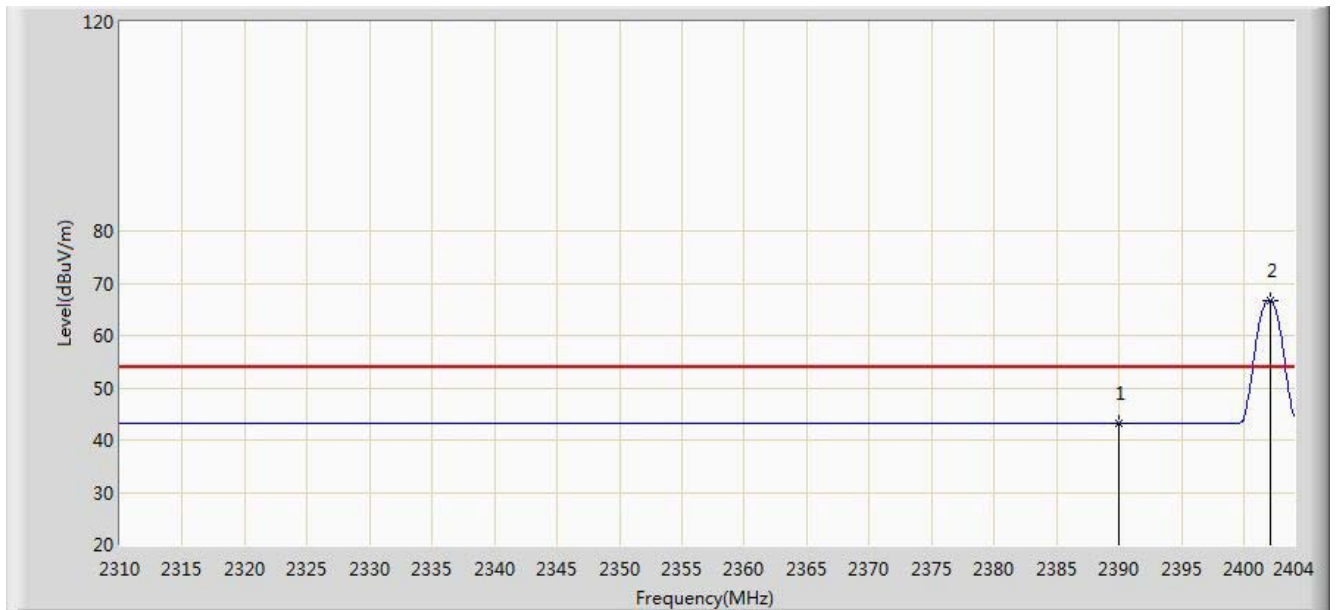

No	Flag	Mark	Frequency (MHz)	Measure Level (dBuV/m)	Reading Level (dBuV)	Over Limit (dB)	Limit (dBuV/m)	Factor (dB)	Type
1			2390.000	43.208	12.524	-10.792	54.000	30.684	AV
2		*	2402.073	66.776	36.115	N/A	N/A	30.661	AV

Note: Measure Level (dBμV/m) = Reading Level (dBμV) + Factor (dB)

Factor (dB) = Cable Loss (dB) + Antenna Factor (dB/m)

Engineer: Milo Li	
Site: AC1	Time: 2014/11/03 - 19:41
Limit: FCC_Part15.209_RE(3m)	Margin: 0
Probe: BBHA9120D_1-18GHz	Polarity: Horizontal
EUT: 8 Inch Tablet	Power: AC 120V/60Hz
Test Mode: BLE at channel 2480MHz	

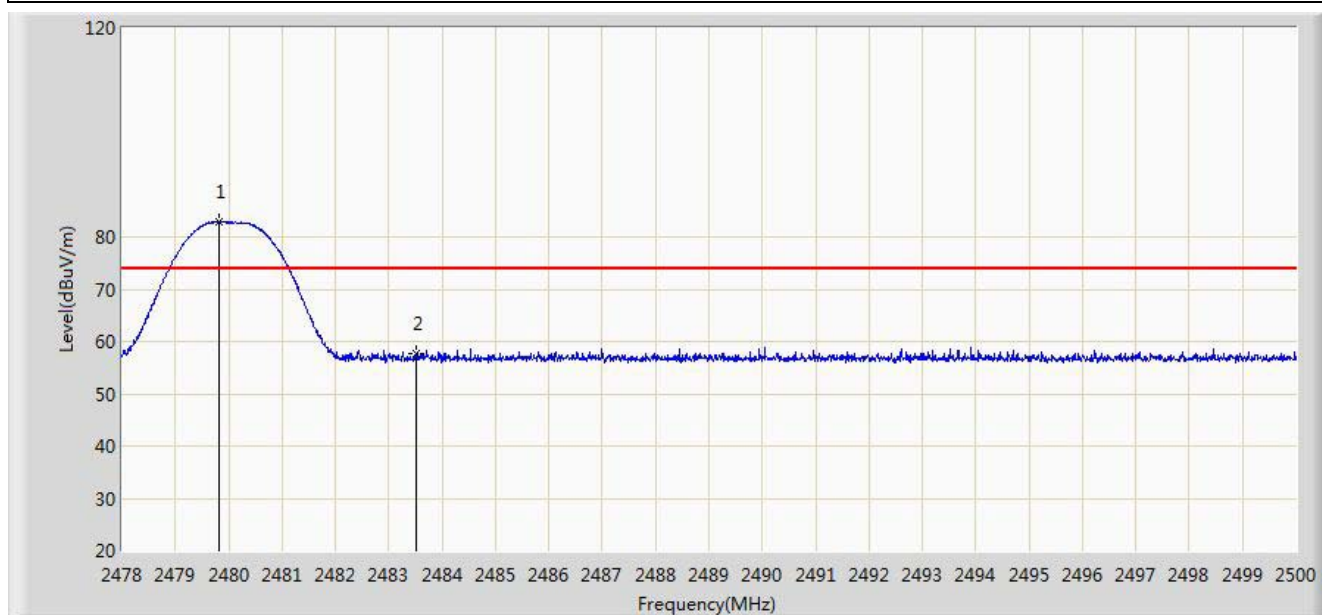

No	Flag	Mark	Frequency (MHz)	Measure Level (dBuV/m)	Reading Level (dBuV)	Over Limit (dB)	Limit (dBuV/m)	Factor (dB)	Type
1		*	2479.815	82.895	52.233	N/A	N/A	30.662	PK
2			2483.500	57.574	26.901	-16.426	74.000	30.673	PK

Note: Measure Level (dB μ V/m) = Reading Level (dB μ V) + Factor (dB)

Factor (dB) = Cable Loss (dB) + Antenna Factor (dB/m)

Engineer: Milo Li	
Site: AC1	Time: 2014/11/03 - 19:56
Limit: FCC_Part15.209_RE(3m)	Margin: 0
Probe: BBHA9120D_1-18GHz	Polarity: Horizontal
EUT: 8 Inch Tablet	Power: AC 120V/60Hz
Test Mode: BLE at channel 2480MHz	

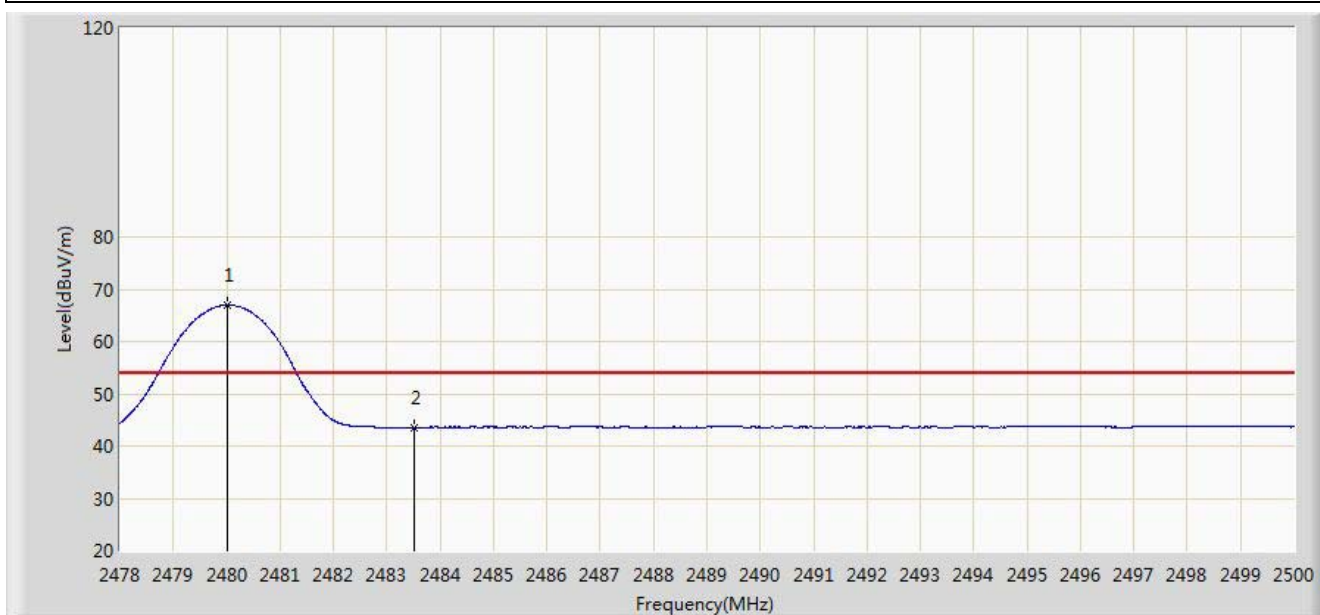

No	Flag	Mark	Frequency (MHz)	Measure Level (dBuV/m)	Reading Level (dBuV)	Over Limit (dB)	Limit (dBuV/m)	Factor (dB)	Type
1		*	2480.002	66.961	36.299	N/A	N/A	30.662	AV
2			2483.500	43.572	12.899	-10.428	54.000	30.673	AV

Note: Measure Level (dB μ V/m) = Reading Level (dB μ V) + Factor (dB)

Factor (dB) = Cable Loss (dB) + Antenna Factor (dB/m)

Engineer: Milo Li	
Site: AC1	Time: 2014/11/03 - 19:56
Limit: FCC_Part15.209_RE(3m)	Margin: 0
Probe: BBHA9120D_1-18GHz	Polarity: Vertical
EUT: 8 Inch Tablet	Power: AC 120V/60Hz
Test Mode: BLE at channel 2480MHz	

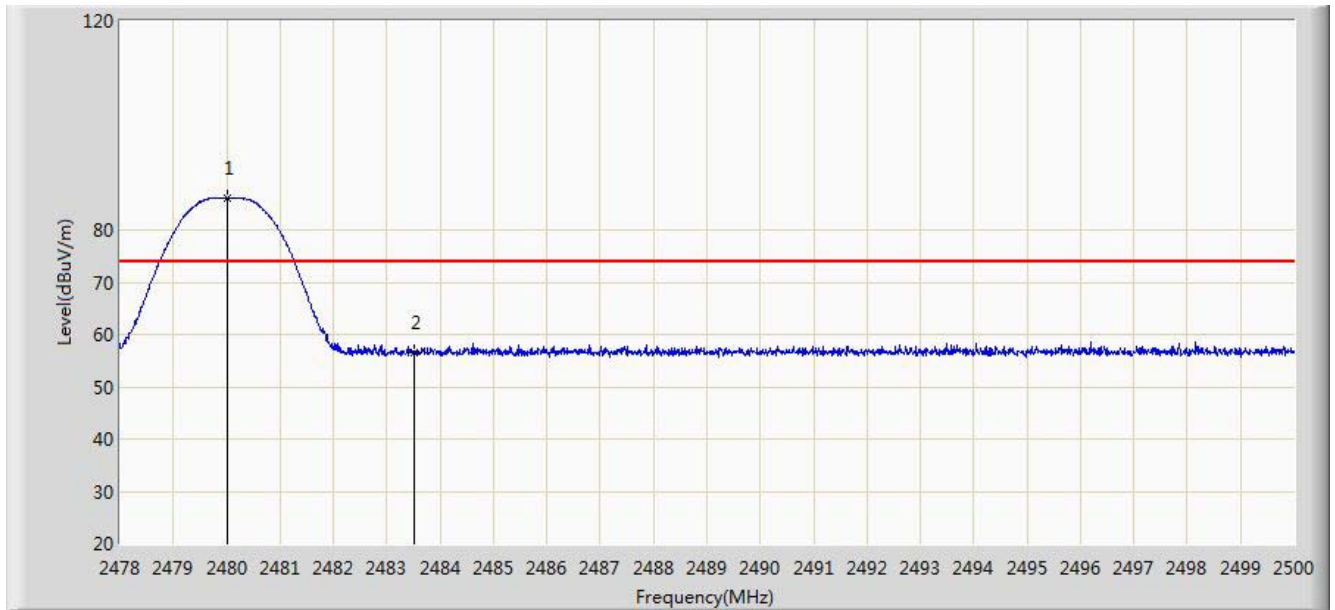

No	Flag	Mark	Frequency (MHz)	Measure Level (dBuV/m)	Reading Level (dBuV)	Over Limit (dB)	Limit (dBuV/m)	Factor (dB)	Type
1		*	2480.002	86.012	55.350	N/A	N/A	30.662	PK
2			2483.500	56.506	25.833	-17.494	74.000	30.673	PK

Note: Measure Level (dBμV/m) = Reading Level (dBμV) + Factor (dB)

Factor (dB) = Cable Loss (dB) + Antenna Factor (dB/m)

Engineer: Milo Li	
Site: AC1	Time: 2014/10/28 - 09:57
Limit: FCC_Part15.209_RE(3m)	Margin: 0
Probe: BBHA9120D_1-18GHz	Polarity: Vertical
EUT: 8 Inch Tablet	Power: AC 120V/60Hz
Test Mode: BLE at channel 2480MHz	

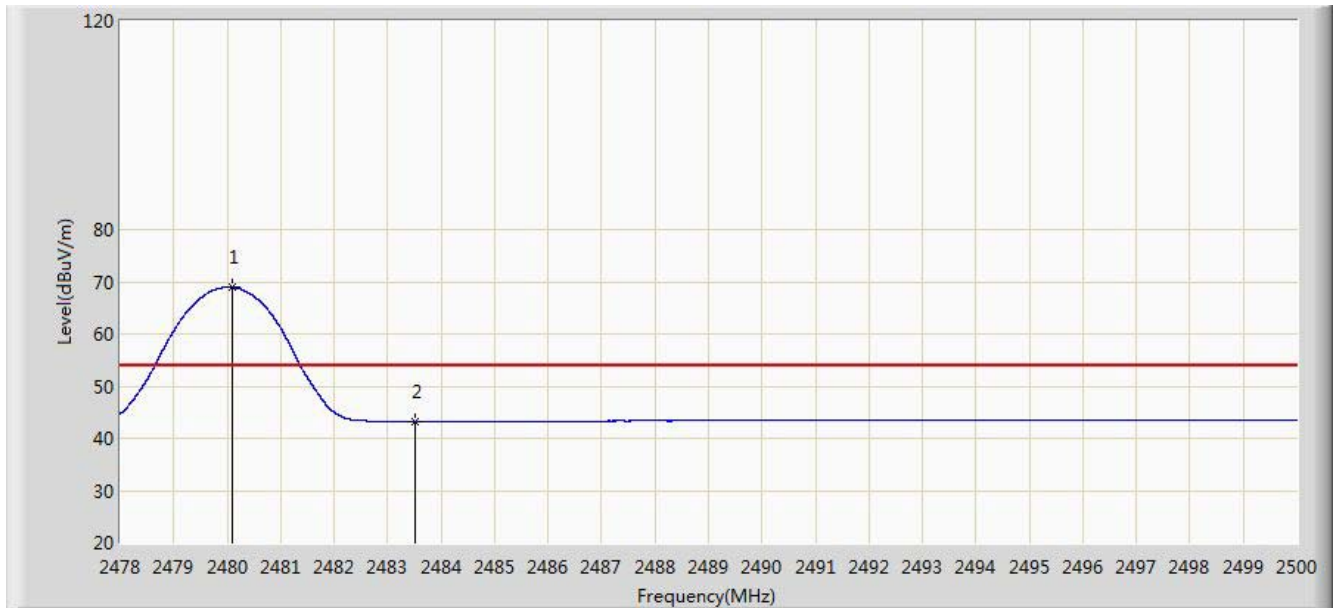

No	Flag	Mark	Frequency (MHz)	Measure Level (dBuV/m)	Reading Level (dBuV)	Over Limit (dB)	Limit (dBuV/m)	Factor (dB)	Type
1		*	2480.106	68.921	38.258	N/A	N/A	30.662	AV
2			2483.500	43.224	12.551	-10.776	54.000	30.673	AV

Note: Measure Level (dB μ V/m) = Reading Level (dB μ V) + Factor (dB)

Factor (dB) = Cable Loss (dB) + Antenna Factor (dB/m)

7.8. AC Conducted Emissions Measurement

7.8.1. Test Limit

FCC Part 15 Subpart C Paragraph 15.207 Limits		
Frequency (MHz)	QP (dBuV)	AV (dBuV)
0.15 - 0.50	66 - 56	56 - 46
0.50 - 5.0	56	46
5.0 - 30	60	50

Note 1: The lower limit shall apply at the transition frequencies.

Note 2: The limit decreases linearly with the logarithm of the frequency in the range 0.15MHz to 0.5MHz.

7.8.2. Test Setup

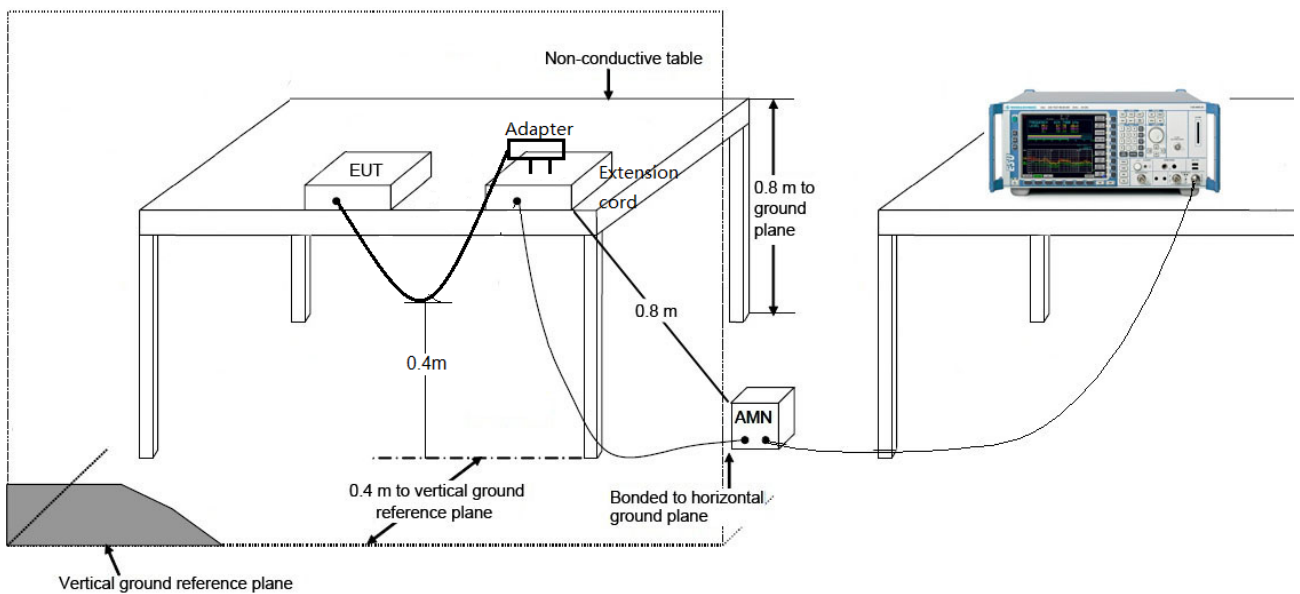

7.8.3. Test Result

Engineer: Milo Li	
Site: SR2	Time: 2014/10/27 - 19:21
Limit: FCC_Part15.207_CE_AC Power	Margin: 0
Probe: ENV216_101683_Filter On	Polarity: Line
EUT: 8 Inch Tablet	Power: AC 120V/60Hz
Note: Normal Operation	

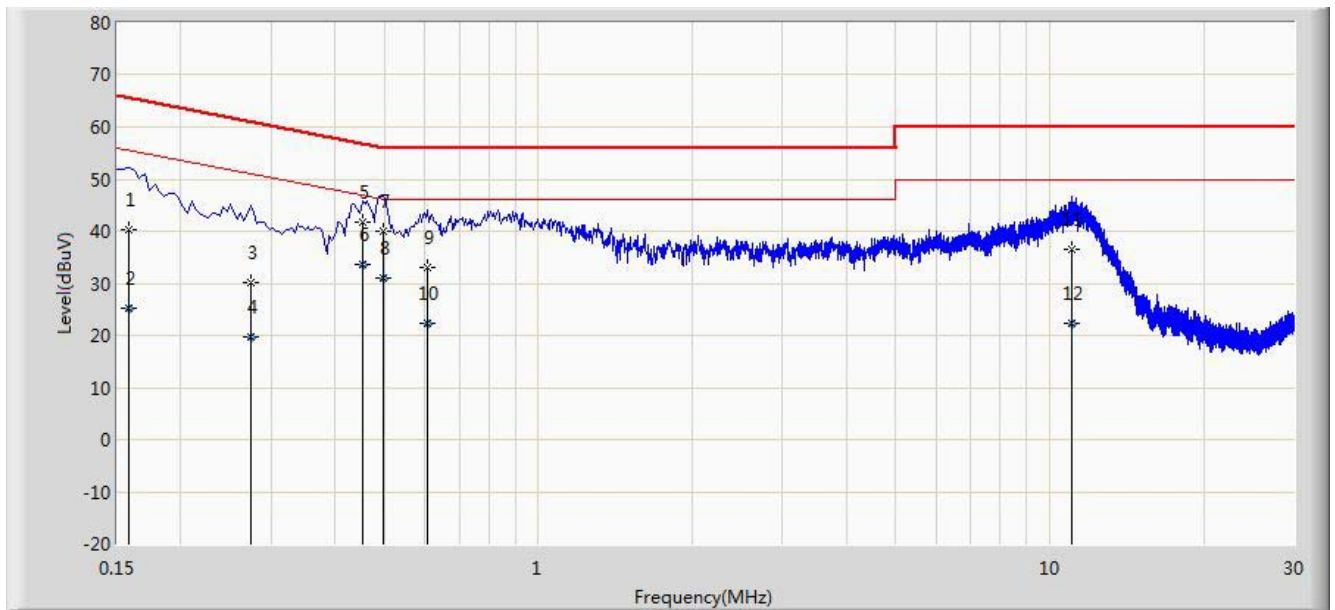

No	Flag	Mark	Frequency (MHz)	Measure Level (dBuV)	Reading Level (dBuV)	Over Limit (dB)	Limit (dBuV)	Factor (dB)	Type
1			0.158	40.168	29.858	-25.400	65.568	10.311	QP
2			0.158	25.083	14.772	-30.486	55.568	10.311	AV
3			0.274	30.047	20.064	-30.949	60.996	9.983	QP
4			0.274	19.673	9.690	-31.323	50.996	9.983	AV
5			0.454	41.601	31.471	-15.201	56.802	10.129	QP
6		*	0.454	33.767	23.638	-13.034	46.802	10.129	AV
7			0.498	40.000	29.842	-16.034	56.033	10.157	QP
8			0.498	30.994	20.836	-15.040	46.033	10.157	AV
9			0.606	33.112	23.000	-22.888	56.000	10.112	QP
10			0.606	22.257	12.145	-23.743	46.000	10.112	AV
11			11.006	36.432	26.326	-23.568	60.000	10.107	QP
12			11.006	22.357	12.251	-27.643	50.000	10.107	AV

Note: Measure Level (dBμV) = Reading Level (dBμV) + Factor (dB)

Factor (dB) = Cable Loss (dB) + LISN Factor (dB).

Engineer: Milo Li	
Site: SR2	Time: 2014/10/29 - 09:58
Limit: FCC_Part15.207_CE_AC Power	Margin: 0
Probe: ENV216_101683_Filter On	Polarity: Neutral
EUT: 8 Inch Tablet	Power: AC 120V/60Hz
Note: Normal Operation	

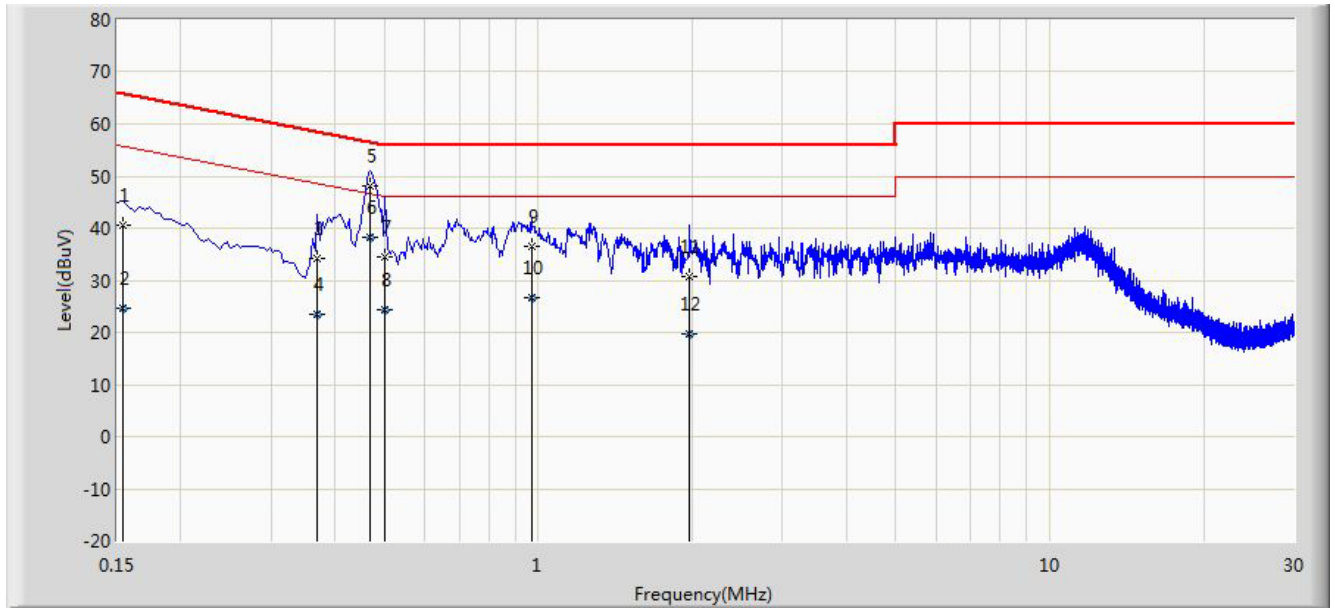

No	Flag	Mark	Frequency (MHz)	Measure Level (dBuV)	Reading Level (dBuV)	Over Limit (dB)	Limit (dBuV)	Factor (dB)	Type
1			0.154	40.685	29.970	-25.096	65.781	10.716	QP
2			0.154	24.724	14.008	-31.057	55.781	10.716	AV
3			0.370	34.267	24.177	-24.234	58.501	10.090	QP
4			0.370	23.344	13.254	-25.157	48.501	10.090	AV
5			0.470	48.137	37.973	-8.377	56.514	10.164	QP
6		*	0.470	38.143	27.979	-8.371	46.514	10.164	AV
7			0.502	34.597	24.420	-21.403	56.000	10.177	QP
8			0.502	24.492	14.315	-21.508	46.000	10.177	AV
9			0.970	36.530	26.605	-19.470	56.000	9.925	QP
10			0.970	26.781	16.856	-19.219	46.000	9.925	AV
11			1.978	30.776	20.903	-25.224	56.000	9.874	QP
12			1.978	19.573	9.699	-26.427	46.000	9.874	AV

Note: Measure Level (dBμV) = Reading Level (dBμV) + Factor (dB)

Factor (dB) = Cable Loss (dB) + LISN Factor (dB)

8. CONCLUSION

The data collected relate only the item(s) tested and show that the **8 Inch Tablet FCC ID:**

XHWEWT816 is in compliance with Part 15C of the FCC Rules.

The End