



FCC Part 15C Test Report

FCC ID: XHWEGQ178

Product Name:	7.9 inch tablet
Trademark:	E-matic
Model Name :	EGQ178, EGQ178BL, EGQ178BU, EGQ178PR, EGQ178PN, EGQ178RD
Prepared For :	E-matic
Address :	3435 Ocean Park Blvd # 107 PMB#444 Santa Monica CA 90405 Los Angeles, CA 90405.
Prepared By :	Shenzhen BCTC Technology Co., Ltd.
Address :	No.101,Yousong Road,Longhua New District, Shenzhen,China
Test Date:	Feb. 03 - Feb. 17, 2015
Date of Report :	Feb. 17, 2015
Report No.:	BCTC-150100528



TEST RESULT CERTIFICATION

Applicant's name : E-matic
Address : 3435 Ocean Park Blvd # 107 PMB#444 Santa Monica CA 90405
 Los Angeles, CA 90405.
Manufacture's Name..... : Shaghal Ltd
Address : 2231 Colby Ave. L.A., C.A., 90064 U.S.A

Product description

Product name : 7.9 inch tablet
Model and/or type reference : EGQ178
Trade Name : E-matic
Serial Model : EGQ178BL, EGQ178BU, EGQ178PR, EGQ178PN,
 EGQ178RD

Standards : FCC Part15.247

Test procedure ANSI C63.4-2003

This device described above has been tested by BCTC, and the test results show that the equipment under test (EUT) is in compliance with the FCC requirements. And it is applicable only to the tested sample identified in the report.

This report shall not be reproduced except in full, without the written approval of BCTC, this document may be altered or revised by BCTC, personal only, and shall be noted in the revision of the document.

Date of Test :
Date (s) of performance of tests : Feb. 03 - Feb. 17, 2015
Date of Issue..... : Feb. 17, 2015
Test Result..... : **Pass**

Testing Engineer : Eric Yang
 (Eric Yang)

Technical Manager : Sophie Lee
 (Sophia Lee)

Authorized Signatory : Carson Zhang
 (Carson. Zhang)



**Table of Contents**

	Page
1 . SUMMARY OF TEST RESULTS	5
1.1 TEST FACILITY	6
1.2 MEASUREMENT UNCERTAINTY	6
2 . GENERAL INFORMATION	7
2.1 GENERAL DESCRIPTION OF EUT	7
2.2 DESCRIPTION OF TEST MODES	9
2.3 TABLE OF PARAMETERS OF TEXT SOFTWARE SETTING	9
2.4 BLOCK DIGRAM SHOWING THE CONFIGURATION OF SYSTEM TESTED	10
2.5 DESCRIPTION OF SUPPORT UNITS(CONDUCTED MODE)	11
2.6 EQUIPMENTS LIST FOR ALL TEST ITEMS	12
3 . EMC EMISSION TEST	13
3.1 CONDUCTED EMISSION MEASUREMENT	13
3.1.1 POWER LINE CONDUCTED EMISSION LIMITS	13
3.1.2 TEST PROCEDURE	14
3.1.3 DEVIATION FROM TEST STANDARD	14
3.1.4 TEST SETUP	14
3.1.5 EUT OPERATING CONDITIONS	14
3.1.6 TEST RESULTS	15
3.2 RADIATED EMISSION MEASUREMENT	17
3.2.1 RADIATED EMISSION LIMITS	17
3.2.2 TEST PROCEDURE	17
3.2.3 DEVIATION FROM TEST STANDARD	18
3.2.4 TEST SETUP	19
3.2.5 EUT OPERATING CONDITIONS	20
3.2.6 TEST RESULTS (BELOW 30 MHZ)	21
3.2.7 TEST RESULTS (BETWEEN 30M – 1000 MHZ)	22
3.2.8 TEST RESULTS (ABOVE 1000 MHZ)	24
3.2.9 TEST RESULTS (RESTRICTED BANDS REQUIREMENTS)	42
4 . NUMBER OF HOPPING CHANNEL	54
4.1 APPLIED PROCEDURES / LIMIT	54
4.1.1 TEST PROCEDURE	54
4.1.2 DEVIATION FROM STANDARD	54

**Table of Contents**

	Page
4.1.3 TEST SETUP	54
4.1.4 EUT OPERATION CONDITIONS	54
4.1.5 TEST RESULTS	55
5 . AVERAGE TIME OF OCCUPANCY	56
5.1 APPLIED PROCEDURES / LIMIT	56
5.1.1 TEST PROCEDURE	56
5.1.2 DEVIATION FROM STANDARD	56
5.1.3 TEST SETUP	57
5.1.4 EUT OPERATION CONDITIONS	57
5.1.5 TEST RESULTS	58
6 . HOPPING CHANNEL SEPARATION MEASUREMENT	60
6.1 APPLIED PROCEDURES / LIMIT	60
6.1.1 TEST PROCEDURE	60
6.1.2 DEVIATION FROM STANDARD	60
6.1.3 TEST SETUP	60
6.1.4 EUT OPERATION CONDITIONS	60
6.1.5 TEST RESULTS	61
7 . BANDWIDTH TEST	67
7.1 APPLIED PROCEDURES / LIMIT	67
7.1.1 TEST PROCEDURE	67
7.1.2 DEVIATION FROM STANDARD	67
7.1.3 TEST SETUP	67
7.1.4 EUT OPERATION CONDITIONS	67
7.1.5 TEST RESULTS	68
8 . PEAK OUTPUT POWER TEST	74
8.1 APPLIED PROCEDURES / LIMIT	74
8.1.1 TEST PROCEDURE	74
8.1.2 DEVIATION FROM STANDARD	74
8.1.3 TEST SETUP	74
8.1.4 EUT OPERATION CONDITIONS	74
8.1.5 TEST RESULTS	75
9 . EUT TEST PHOTO	82
APPENDIX-PHOTOGRAPHS OF EUT CONSTRUCTIONAL DETAILS	



1. SUMMARY OF TEST RESULTS

Test procedures according to the technical standards:

FCC Part15 (15.247) , Subpart C			
Standard Section	Test Item	Judgment	Remark
15.207	Conducted Emission	PASS	
15.247(a)(1)	Hopping Channel Separation	PASS	
15.247(b)(1)	Peak Output Power	PASS	
15.247(c)	Radiated Spurious Emission	PASS	
15.247(a)(iii)	Number of Hopping Frequency	PASS	
15.247(a)(iii)	Dwell Time	PASS	
15.247(a)(1)	Bandwidth	PASS	
15.205	Band Edge Emission	PASS	
15.203	Antenna Requirement	PASS	

NOTE:

(1) "N/A" denotes test is not applicable in this Test Report



1.1 TEST FACILITY

Shenzhen BCTC Technology Co., Ltd.

Add. : No.101,Yousong Road,Longhua New District, Shenzhen,China

FCC Registered No.: 187086

1.2 MEASUREMENT UNCERTAINTY

The reported uncertainty of measurement $y \pm U$, where expanded uncertainty U is based on a standard uncertainty multiplied by a coverage factor of $k=2$, providing a level of confidence of approximately **95 %**.

No.	Item	Uncertainty
1	Conducted Emission Test	$\pm 1.38\text{dB}$
2	RF power,conducted	$\pm 0.16\text{dB}$
3	Spurious emissions,conducted	$\pm 0.21\text{dB}$
4	All emissions,radiated(<1G)	$\pm 4.68\text{dB}$
5	All emissions,radiated(>1G)	$\pm 4.89\text{dB}$
6	Temperature	$\pm 0.5^{\circ}\text{C}$
7	Humidity	$\pm 2\%$



2. GENERAL INFORMATION

2.1 GENERAL DESCRIPTION OF EUT

Equipment	7.9 inch tablet	
Trade Name	E-matic	
Model Name	EGQ178	
Serial Model	EGQ178BL, EGQ178BU, EGQ178PR, EGQ178PN, EGQ178RD	
Model Difference	All the same, Only model name is different.	
Product Description	The EUT is a 7.9 inch tablet	
	Operation Frequency:	2402~2480 MHz
	Modulation Type:	BT(1Mbps): GFSK BT EDR(2Mbps): $\pi/4$ -DQPSK BT EDR(3Mbps): 8-DPSK
	Bit Rate of Transmitter	1Mbps/2Mbps/3Mbps
	Number Of Channel	79 CH
	Antenna Designation:	Please see Note 3.
	Output Power(Conducted):	BT(1Mbps): 1.462dBm BT EDR(2Mbps): 0.685dBm BT EDR(3Mbps): -0.736dBm
	Based on the application, features, or specification exhibited in User's Manual, the EUT is considered as an ITE/Computing Device. More details of EUT technical specification, please refer to the User's Manual.	
Channel List	Please refer to the Note 2.	
Adapter	Model: PGAE0500200U1UL AC Power Input: 100-240V~, 50/60Hz, 0.3A Output: 5.0V---, 2.0A	
Battery	DC3.7V	
Connecting I/O Port(s)	Please refer to the User's Manual	

Note:

1. For a more detailed features description, please refer to the manufacturer's specifications or the User's Manual.

2.

Channel List					
Channel	Frequency (MHz)	Channel	Frequency (MHz)	Channel	Frequency (MHz)
00	2402	27	2429	54	2456
01	2403	28	2430	55	2457
02	2404	29	2431	56	2458
03	2405	30	2432	57	2459
04	2406	31	2433	58	2460
05	2407	32	2434	59	2461
06	2408	33	2435	60	2462



07	2409	34	2436	61	2463
08	2410	35	2437	62	2464
09	2411	36	2438	63	2465
10	2412	37	2439	64	2466
11	2413	38	2440	65	2467
12	2414	39	2441	66	2468
13	2415	40	2442	67	2469
14	2416	41	2443	68	2470
15	2417	42	2444	69	2471
16	2418	43	2445	70	2472
17	2419	44	2446	71	2473
18	2420	45	2447	72	2474
19	2421	46	2448	73	2475
20	2422	47	2449	74	2476
21	2423	48	2450	75	2477
22	2424	49	2451	76	2478
23	2425	50	2452	77	2479
24	2426	51	2453	78	2480
25	2427	52	2454		
26	2428	53	2455		

3.

Table for Filed Antenna

Ant	Brand	Model Name	Antenna Type	Connector	Gain (dBi)	NOTE
1	N/A	N/A	FPCB Antenna	NA	1.0	BT Antenna



2.2 DESCRIPTION OF TEST MODES

To investigate the maximum EMI emission characteristics generated from EUT, the test system was pre-scanning tested based on the consideration of following EUT operation mode or test configuration mode which possibly have effect on EMI emission level. Each of these EUT operation mode(s) or test configuration mode(s) mentioned above was evaluated respectively.

Pretest Mode	Description
Mode 1	CH00
Mode 2	CH39
Mode 3	CH78
Mode 4	BT Link Mode

For Conducted Emission	
Final Test Mode	Description
Mode 4	BT Link Mode

For Radiated Emission	
Final Test Mode	Description
Mode 1	CH00
Mode 2	CH39
Mode 3	CH78

Note:

(1) The measurements are performed at the highest, middle, lowest available channels.

(2) The data rate was set in 1Mbps for radiated emission due to the highest RF output power.

2.3 TABLE OF PARAMETERS OF TEST SOFTWARE SETTING

During testing channel & power controlling software provided by the customer was used to control the operating channel as well as the output power level. The RF output power selection is for the setting of RF output power expected by the customer and is going to be fixed on the firmware of the final end product power parameters of FHSS

Test software Version	Test program: BC5		
Frequency	2402 MHz	2441 MHz	2480 MHz
Parameters(1Mbps)	DEF	DEF	DEF
Parameters(2Mbps)	DEF	DEF	DEF
Parameters(3Mbps)	DEF	DEF	DEF



2.4 BLOCK DIGRAM SHOWING THE CONFIGURATION OF SYSTEM TESTED

Conducted Emission Test

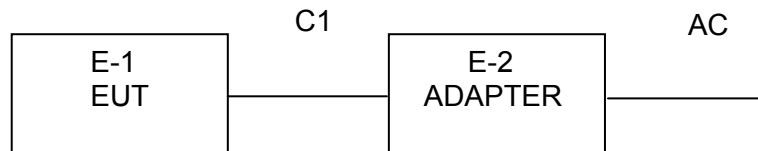

Radiated Spurious Emission Test

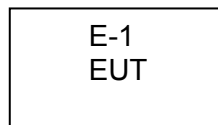



2.5 DESCRIPTION OF SUPPORT UNITS(CONDUCTED MODE)

The EUT has been tested as an independent unit together with other necessary accessories or support units. The following support units or accessories were used to form a representative test configuration during the tests.

Item	Equipment	Mfr/Brand	Model/Type No.	Series No.	Note
E-1	7.9 inch tablet	N/A	EGQ178	N/A	EUT
E-2	Adapter	N/A	PGAE0500200U1UL	N/A	

Item	Shielded Type	Ferrite Core	Length	Note
C-1	NO	NO	0.9m	

Note:

- (1) The support equipment was authorized by Declaration of Confirmation.
- (2) For detachable type I/O cable should be specified the length in cm in 『Length』 column.
- (3) “YES” is means “shielded” “with core”; “NO” is means “unshielded” “without core”.



2.6 EQUIPMENTS LIST FOR ALL TEST ITEMS

Radiation Test equipment

Item	Kind of Equipment	Manufacturer	Type No.	Serial No.	Last calibration	Calibrated until	Calibration period
1	Spectrum Analyzer	Agilent	E4407B	MY45109572	2014.08.25	2015.08.24	1 year
2	Test Receiver	R&S	ESPI	101396	2014.08.25	2015.08.24	1 year
3	Bilog Antenna	SCHWARZBECK	VULB9160	VULB9160-3369	2014.08.25	2015.08.24	1 year
4	50Ω Coaxial Switch	Anritsu	MP59B	6200264416	2014.06.07	2015.06.06	1 year
5	Spectrum Analyzer	ADVANTEST	R3132	150900201	2014.06.07	2015.06.06	1 year
6	Horn Antenna	SCHWARZBECK	9120D	9120D-1275	2014.08.25	2015.08.24	1 year
7	Horn Ant	Schwarzbeck	BBHA 9170	9170-181	2014.07.06	2015.07.05	1 year
8	Amplifier	SCHWARZBECK	BBV9718	9718-270	2014.08.25	2015.08.24	1 year
9	Amplifier	SCHWARZBECK	BBV9743	9743-119	2014.08.25	2015.08.24	1 year
10	Loop Antenna	ARA	PLA-1030/B	1029	2014.06.08	2015.06.07	1 year
11	Power Meter	R&S	NRVS	100696	2014.07.06	2015.07.05	1 year
12	Power Sensor	R&S	URV5-Z4	0395.1619.05	2014.07.06	2015.07.05	1 year
13	RF cables	R&S	N/A	N/A	2014.07.06	2015.07.05	1 year

Conduction Test equipment

Item	Kind of Equipment	Manufacturer	Type No.	Serial No.	Last calibration	Calibrated until	Calibration period
1	Test Receiver	R&S	ESCI	101421	2014.08.25	2015.08.24	1 year
2	LISN	SCHWARZBECK	NSLK8127	812779	2014.08.25	2015.08.24	1 year
3	LISN	EMCO	Feb-16	42990	2014.08.24	2015.08.23	1 year
4	50Ω Coaxial Switch	Anritsu	MP59B	6200264417	2014.06.07	2015.06.06	1 year
5	Passive Voltage Probe	R&S	ESH2-Z3	100196	2014.06.07	2015.06.06	1 year



3. EMC EMISSION TEST

3.1 CONDUCTED EMISSION MEASUREMENT

3.1.1 POWER LINE CONDUCTED EMISSION Limits (Frequency Range 150KHz-30MHz)

FREQUENCY (MHz)	Class A (dBuV)		Class B (dBuV)		Standard
	Quasi-peak	Average	Quasi-peak	Average	
0.15 -0.5	79.00	66.00	66 - 56 *	56 - 46 *	CISPR
0.50 -5.0	73.00	60.00	56.00	46.00	CISPR
5.0 -30.0	73.00	60.00	60.00	50.00	CISPR

0.15 -0.5	79.00	66.00	66 - 56 *	56 - 46 *	FCC
0.50 -5.0	73.00	60.00	56.00	46.00	FCC
5.0 -30.0	73.00	60.00	60.00	50.00	FCC

Note:

- (1) The tighter limit applies at the band edges.
- (2) The limit of " * " marked band means the limitation decreases linearly with the logarithm of the frequency in the range.

The following table is the setting of the receiver

Receiver Parameters	Setting
Attenuation	10 dB
Start Frequency	0.15 MHz
Stop Frequency	30 MHz
IF Bandwidth	9 kHz

3.1.2 TEST PROCEDURE

- The EUT was placed 0.4 meters from the horizontal ground plane with EUT being connected to the power mains through a line impedance stabilization network (LISN). All other support equipments powered from additional LISN(s). The LISN provide 50 Ohm/ 50uH of coupling impedance for the measuring instrument.
- Interconnecting cables that hang closer than 40 cm to the ground plane shall be folded back and forth in the center forming a bundle 30 to 40 cm long.
- I/O cables that are not connected to a peripheral shall be bundled in the center. The end of the cable may be terminated, if required, using the correct terminating impedance. The overall length shall not exceed 1 m.
- LISN at least 80 cm from nearest part of EUT chassis.
- For the actual test configuration, please refer to the related Item –EUT Test Photos.

3.1.3 DEVIATION FROM TEST STANDARD

No deviation

3.1.4 TEST SETUP

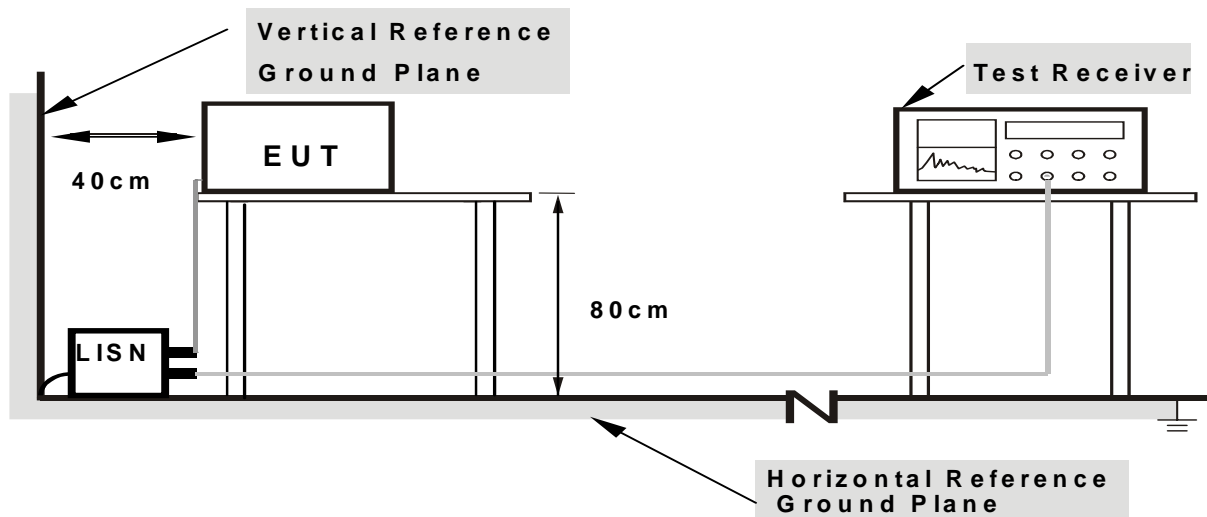

Note: 1. Support units were connected to second LISN.

2. Both of LISNs (AMN) are 80 cm from EUT and at least 80 cm from other units and other metal planes

3.1.5 EUT OPERATING CONDITIONS

The EUT was configured for testing in a typical fashion (as a customer would normally use it). The EUT has been programmed to continuously transmit during test. This operating condition was tested and used to collect the included data.



3.1.6 TEST RESULTS

EUT :	7.9 inch tablet	Model Name. :	EGQ178
Temperature :	26 °C	Relative Humidity :	54%
Pressure :	1010hPa	Phase :	L
Test Voltage :	AC 120V/60Hz	Test Mode :	Mode 4

Remark:

1. All readings are Quasi-Peak and Average values.
2. Factor = Insertion Loss + Cable Loss.

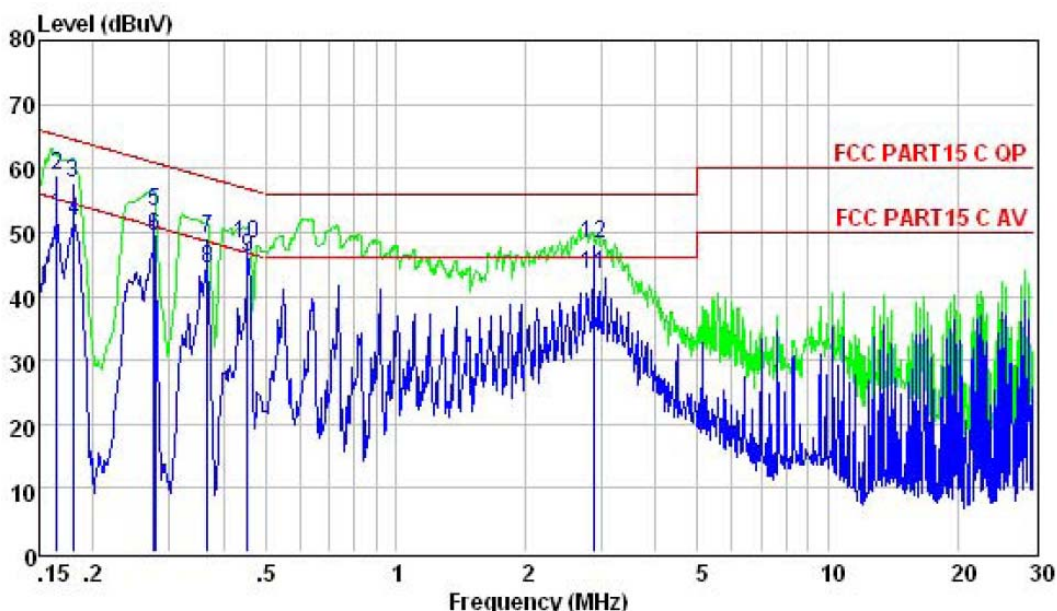

	Freq	Level	Limit	Over	Remark
	MHz	dBuV	dBuV	dB	
1	0.165	52.59	55.21	-2.62	Average
2	0.165	58.90	65.21	-6.31	QP
3	0.180	57.60	64.49	-6.89	QP
4	0.181	51.81	54.46	-2.65	Average
5	0.277	53.10	60.91	-7.81	QP
6	0.277	49.30	50.90	-1.60	Average
7	0.367	49.20	58.57	-9.37	QP
8	0.367	44.17	48.56	-4.39	Average
9	0.454	45.99	46.80	-0.81	Average
10	0.454	48.10	56.80	-8.70	QP
11	2.869	43.30	46.00	-2.70	Average
12	2.869	48.30	56.00	-7.70	QP



EUT :	7.9 inch tablet	Model Name. :	EGQ178
Temperature :	26 °C	Relative Humidity :	54%
Pressure :	1010hPa	Phase :	N
Test Voltage :	AC 120V/60Hz	Test Mode :	Mode 4

Remark:

1. All readings are Quasi-Peak and Average values.
2. Factor = Insertion Loss + Cable Loss.

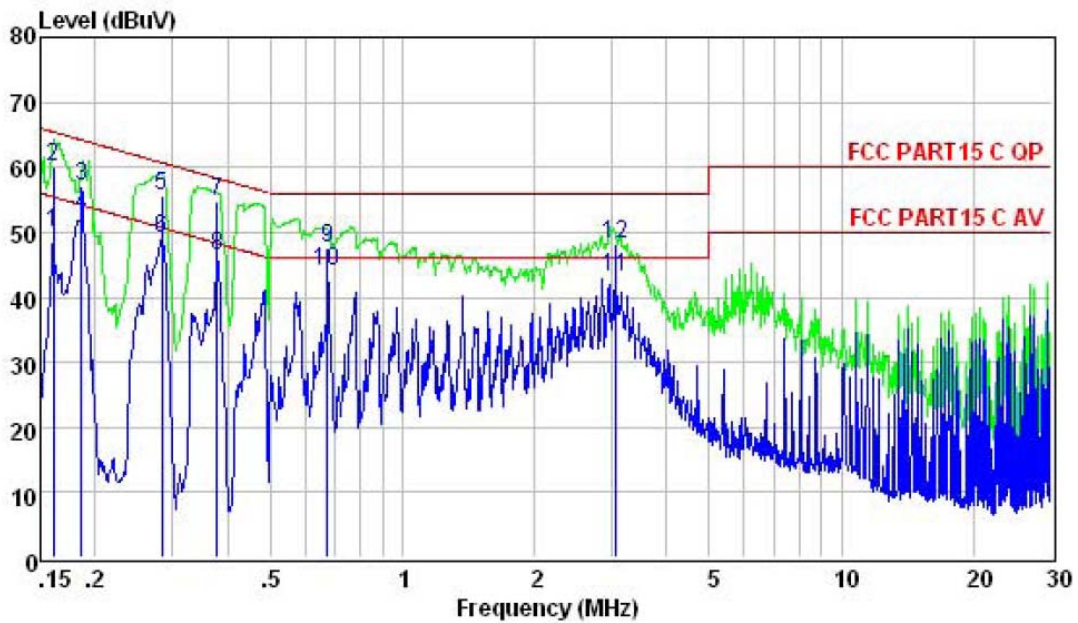

	Freq	Level	Limit	Over	Remark
	MHz	dBuV	dBuV	dB	
1	0.161	50.05	55.43	-5.38	Average
2	0.161	60.10	65.43	-5.33	QP
3	0.186	57.20	64.21	-7.01	QP
4	0.186	52.57	54.20	-1.63	Average
5	0.283	55.74	60.73	-4.99	QP
6	0.283	49.11	50.72	-1.61	Average
7	0.379	54.60	58.30	-3.70	QP
8	0.379	46.48	48.30	-1.82	Average
9	0.675	47.50	56.00	-8.50	QP
10	0.675	43.98	46.00	-2.02	Average
11	3.058	43.18	46.00	-2.82	Average
12	3.058	48.30	56.00	-7.70	QP



3.2 RADIATED EMISSION MEASUREMENT

3.2.1 RADIATED EMISSION LIMITS

20dBc in any 100 kHz bandwidth outside the operating frequency band. In case the emission fall within the restricted band specified on 15.205(a), then the 15.209(a) limit in the table below has to be followed.

Frequencies (MHz)	Field Strength (microrvolts/meter)	Measurement Distance (meters)
0.009~0.490	2400/F(KHz)	300
0.490~1.705	24000/F(KHz)	30
1.705~30.0	30	30
30~88	100	3
88~216	150	3
216~960	200	3
Above 960	500	3

Spectrum Parameter	Setting
Attenuation	Auto
Start Frequency	1000 MHz
Stop Frequency	10th carrier harmonic
RB / VB (emission in restricted band)	1 MHz / 1 MHz for Peak, 1 MHz / 10Hz for Average

Receiver Parameter	Setting
Attenuation	Auto
Start ~ Stop Frequency	9kHz~150kHz / RB 200Hz for QP
Start ~ Stop Frequency	150kHz~30MHz / RB 9kHz for QP
Start ~ Stop Frequency	30MHz~1000MHz / RB 120kHz for QP

3.2.2 TEST PROCEDURE

- The measuring distance of at 3 m shall be used for measurements at frequency up to 1GHz. For frequencies above 1GHz, any suitable measuring distance may be used.
- The EUT was placed on the top of a rotating table 0.8 meters above the ground at a 3 meter open area test site. The table was rotated 360 degrees to determine the position of the highest radiation.
- The height of the equipment or of the substitution antenna shall be 0.8 m; the height of the test antenna shall vary between 1 m to 4 m. Both horizontal and vertical polarizations of the antenna are set to make the measurement.
- The initial step in collecting conducted emission data is a spectrum analyzer peak detector mode pre-scanning the measurement frequency range. Significant peaks are then marked and then Quasi Peak detector mode re-measured.



- e. If the Peak Mode measured value compliance with and lower than Quasi Peak Mode Limit, the EUT shall be deemed to meet QP Limits and then no additional QP Mode measurement performed.
- f. For the actual test configuration, please refer to the related Item –EUT Test Photos.

Note:

Both horizontal and vertical antenna polarities were tested and performed pretest to three orthogonal axis. The worst case emissions were reported

3.2.3 DEVIATION FROM TEST STANDARD

No deviation

3.2.4 TEST SETUP

(A) Radiated Emission Test-Up Frequency Below 30MHz

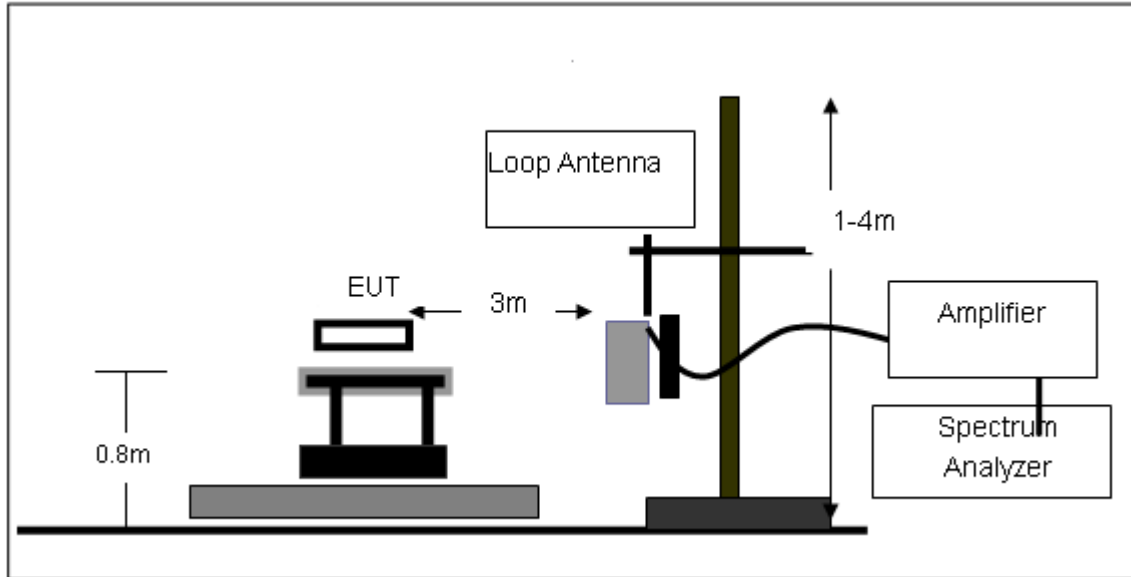

(B) Radiated Emission Test-Up Frequency 30MHz~1GHz

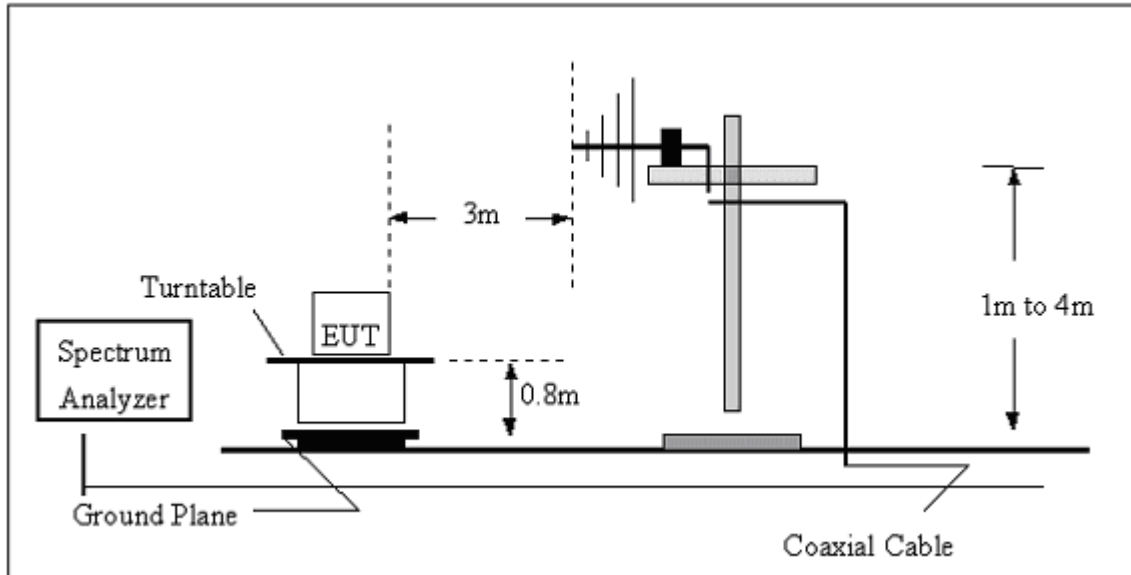

(C) Radiated Emission Test-Up Frequency Above 1GHz

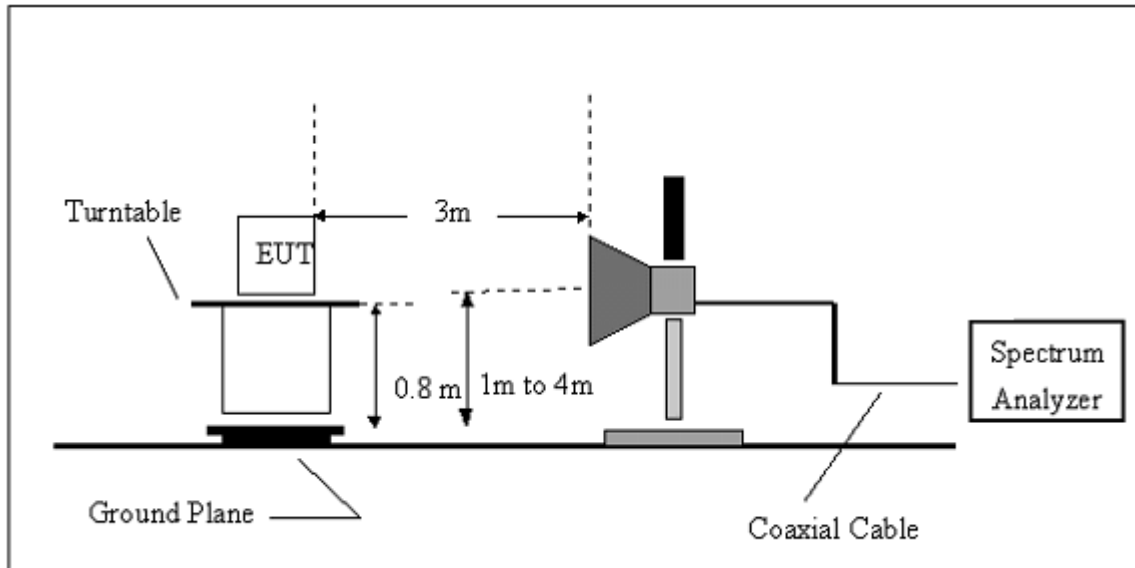

3.2.5 EUT OPERATING CONDITIONS

The EUT tested system was configured as the statements of 2.4 Unless otherwise a special operating condition is specified in the follows during the testing.

**3.2.6 TEST RESULTS (BELOW 30 MHZ)**

EUT :	7.9 inch tablet	Model Name :	EGQ178
Temperature :	26 °C	Relative Humidity :	54%
Pressure :	1010 hPa	Polarization :	---
Test Voltage :	DC 3.7V		
Test Mode :	TX		

Freq.	Reading	Limit	Margin	State
(MHz)	(dBuV/m)	(dBuV/m)	(dB)	P/F
--	--	--	--	PASS
--	--	--	--	PASS

NOTE:

The amplitude of spurious emissions which are attenuated by more than 20dB below the permissible value has no need to be reported.

Distance extrapolation factor = $40 \log(\text{specific distance}/\text{test distance})$ (dB);

Limit line = specific limits(dBuv) + distance extrapolation factor.



3.2.7 TEST RESULTS (BETWEEN 30M – 1000 MHZ)

EUT :	7.9 inch tablet	Model Name :	EGQ178
Temperature :	26 °C	Relative Humidity :	54%
Pressure :	1010 hPa	Polarization :	Horizontal
Test Voltage :	DC 3.7V		
Test Mode :	TX		

Remark:
 Factor = Antenna Factor + Cable Loss – Pre-amplifier.
 All interfaces was connected, and BT TX mode was link.

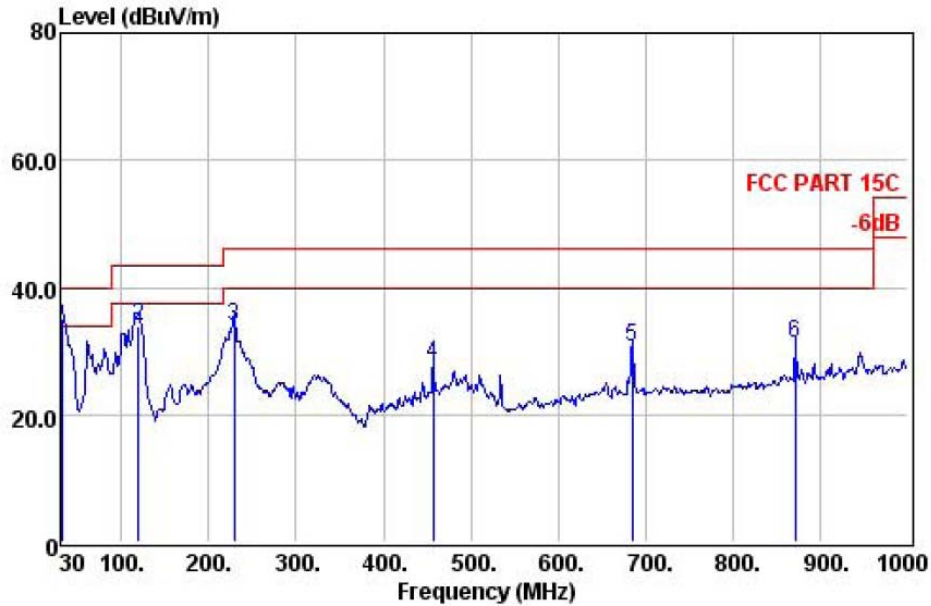

	Preamp	Read	CableAntenna	Limit	Over				
Freq	Factor	Level	Loss	Line	Limit	Remark			
MHz	dB	dBuV	dB	dB/m	dBuV/m	dBuV/m	dB		
1 !	31.94	31.40	48.37	0.56	17.66	35.19	40.00	-4.81	QP
2	119.24	31.24	55.60	1.12	8.56	34.04	43.50	-9.46	QP
3	228.85	30.92	50.84	1.61	12.31	33.84	46.00	-12.16	QP
4	456.80	30.61	38.14	2.62	17.79	27.94	46.00	-18.06	QP
5	684.75	30.73	35.67	3.80	21.96	30.70	46.00	-15.30	QP
6	871.96	30.24	33.47	4.67	23.45	31.35	46.00	-14.65	QP



EUT :	7.9 inch tablet	Model Name :	EGQ178
Temperature :	26 °C	Relative Humidity :	54%
Pressure :	1010 hPa	Polarization :	Vertical
Test Voltage :	DC 3.7V		
Test Mode :	TX		

Remark:
 Factor = Antenna Factor + Cable Loss – Pre-amplifier.
 All interfaces was connected, and BT TX mode was link.

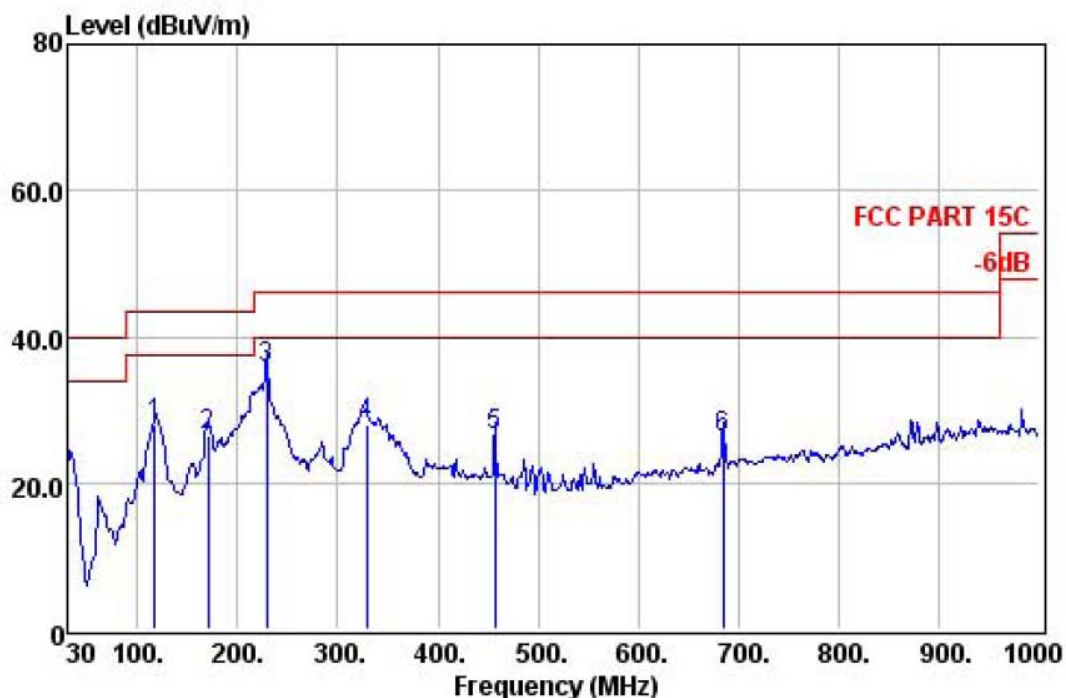

	Preamp	Read	Cable	Antenna	Limit	Over	
Freq	Factor	Level	Loss	Factor	Line	Limit	Remark
MHz	dB	dBuV	dB	dB/m	dBuV/m	dBuV/m	dB
1	117.30	31.25	49.44	1.03	8.72	27.94	43.50 -15.56 QP
2	170.65	31.19	46.35	1.30	10.12	26.58	43.50 -16.92 QP
3	228.85	30.92	52.66	1.61	12.31	35.66	46.00 -10.34 QP
4	328.76	30.79	42.19	2.02	14.65	28.07	46.00 -17.93 QP
5	456.80	30.61	36.60	2.62	17.79	26.40	46.00 -19.60 QP
6	684.75	30.73	31.23	3.80	21.96	26.26	46.00 -19.74 QP



3.2.8 TEST RESULTS (ABOVE 1000 MHZ)

EUT :	7.9 inch tablet	Model Name :	EGQ178
Temperature :	26 °C	Relative Humidity :	54%
Pressure :	1010 hPa	Test Voltage :	DC 3.7V
Test Mode :	TX 2402MHz – CH 00(1Mbps)	Polarization :	Horizontal

Remark:
Factor = Antenna Factor + Cable Loss – Pre-amplifier.

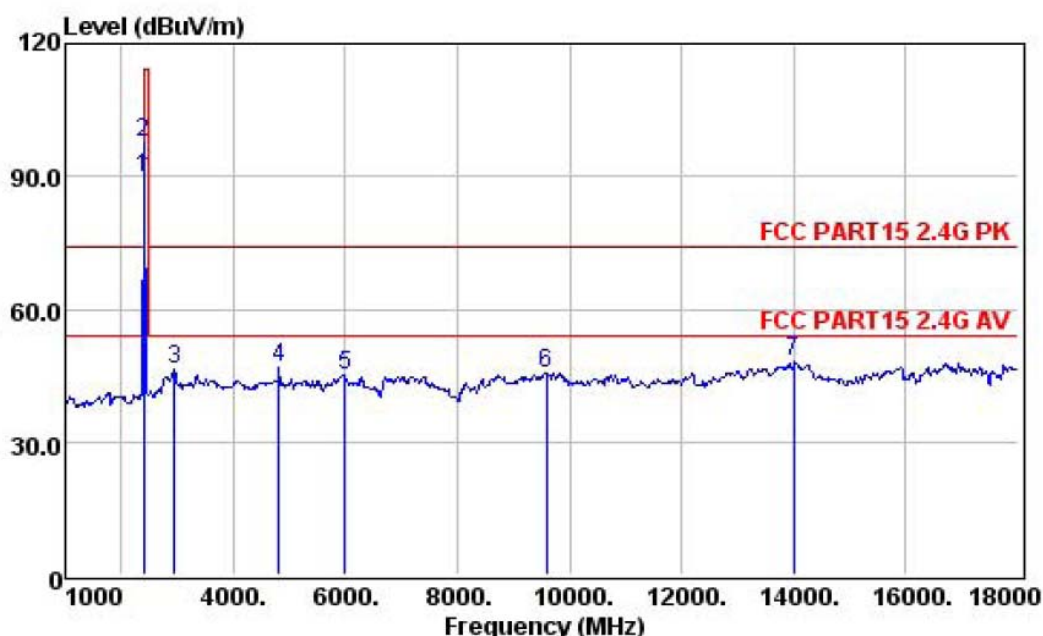

	Preamp	Read	Cable	Antenna	Limit	Over	Remark		
	Freq	Factor	Level	Loss	Factor	Line	Limit		
	MHz	dB	dBuV	dB	dB/m	dBuV/m	dB		
1	2402.00	26.32	79.75	7.34	28.72	89.49	94.00	-4.51	Average
2	2402.00	26.32	87.94	7.34	28.72	97.68	114.00	-16.32	Peak
3	2955.00	26.48	33.08	9.74	29.88	46.22	74.00	-27.78	Peak
4	4804.00	27.49	29.27	11.96	32.94	46.68	74.00	-27.32	Peak
5	5998.00	27.70	21.15	16.53	35.20	45.18	74.00	-28.82	Peak
6	9585.00	28.63	19.28	16.93	38.07	45.65	74.00	-28.35	Peak
7	14005.00	29.40	14.65	19.37	43.50	48.12	74.00	-25.88	Peak



EUT :	7.9 inch tablet	Model Name :	EGQ178
Temperature :	26 °C	Relative Humidity :	54%
Pressure :	1010 hPa	Test Voltage :	DC 3.7V
Test Mode :	TX 2402MHz – CH 00(1Mbps)	Polarization :	Vertical

Remark:
Factor = Antenna Factor + Cable Loss – Pre-amplifier.

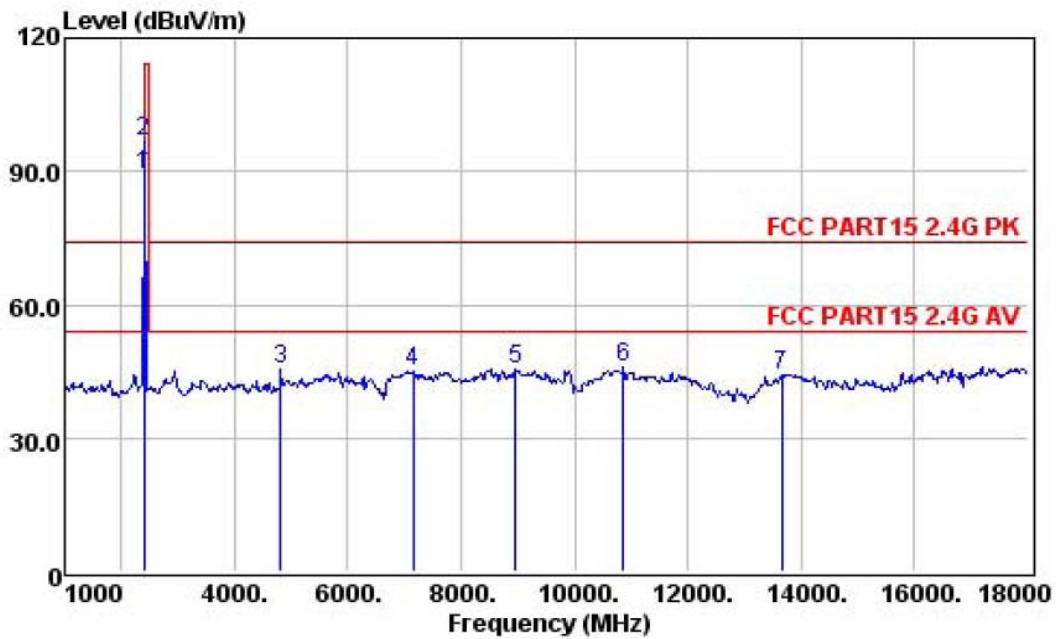

	Preamp Freq	Preamp Factor	Read Level	Cable Loss	Antenna Factor	Level	Limit Line	Over Limit	Remark
	MHz	dB	dBuV	dB	dB/m	dBuV/m	dBuV/m	dB	
1	2402.00	26.32	79.33	7.34	28.72	89.07	94.00	-4.93	Average
2	2402.00	26.32	87.19	7.34	28.72	96.93	114.00	-17.07	Peak
3	4804.00	27.49	28.25	11.96	32.94	45.66	74.00	-28.34	Peak
4	7154.00	27.93	19.04	16.61	37.26	44.98	74.00	-29.02	Peak
5	8956.00	28.38	19.75	16.87	37.34	45.58	74.00	-28.42	Peak
6	10860.00	28.89	18.19	17.14	39.42	45.86	74.00	-28.14	Peak
7	13648.00	29.33	11.41	18.96	43.15	44.19	74.00	-29.81	Peak



EUT :	7.9 inch tablet	Model Name :	EGQ178
Temperature :	26 °C	Relative Humidity :	54%
Pressure :	1010 hPa	Test Voltage :	DC 3.7V
Test Mode :	TX 2441MHz – CH 39(1Mbps)	Polarization :	Vertical

Remark:
Factor = Antenna Factor + Cable Loss – Pre-amplifier.

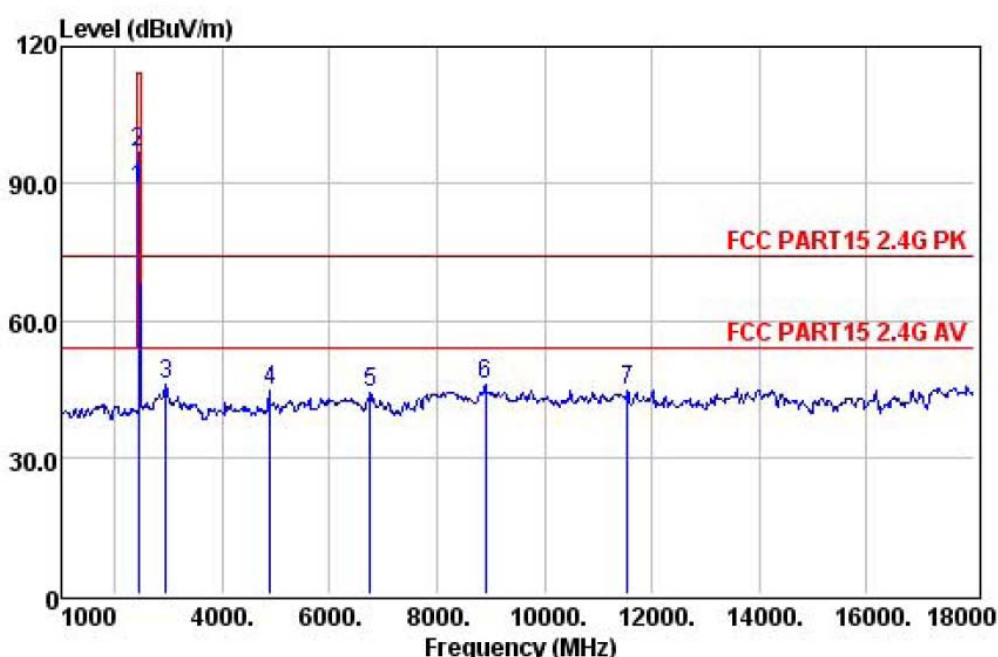

	Preamp Freq	Preamp Factor	Read Level	Cable Loss	Antenna Factor	Limit Line	Over Limit	Remark
	MHz	dB	dBuV	dB	dB/m	dBuV/m	dBuV/m	dB
1	2441.00	26.33	79.06	7.48	28.76	88.97	94.00	-5.03 Average
2	2441.00	26.33	87.05	7.48	28.76	96.96	114.00	-17.04 Peak
3	2955.00	26.48	32.97	9.74	29.88	46.11	74.00	-27.89 Peak
4	4882.00	27.53	26.98	12.14	33.11	44.70	74.00	-29.30 Peak
5	6746.00	27.85	18.86	16.60	36.53	44.14	74.00	-29.86 Peak
6	8905.00	28.37	20.10	16.86	37.28	45.87	74.00	-28.13 Peak
7	11540.00	28.95	16.51	17.27	39.87	44.70	74.00	-29.30 Peak



EUT :	7.9 inch tablet	Model Name :	EGQ178
Temperature :	26 °C	Relative Humidity :	54%
Pressure :	1010 hPa	Test Voltage :	DC 3.7V
Test Mode :	TX 2441MHz – CH 39(1Mbps)	Polarization :	Horizontal

Remark:
Factor = Antenna Factor + Cable Loss – Pre-amplifier.

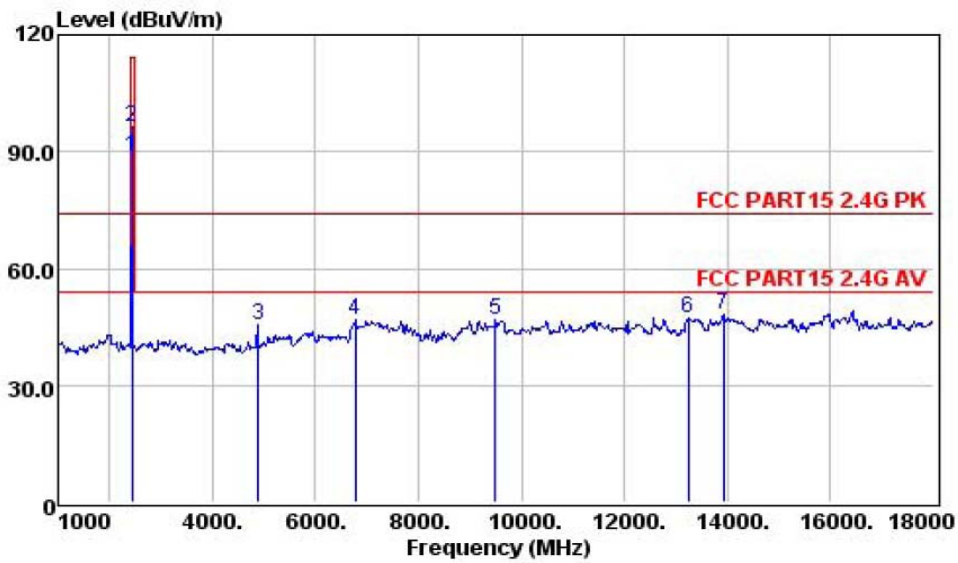

	Preamp Freq	Preamp Factor	Read Level	Cable Loss	Antenna Factor	Level	Limit Line	Over Limit	Remark
	MHz	dB	dBuV	dB	dB/m	dBuV/m	dBuV/m	dB	
1	2441.00	26.33	78.66	7.48	28.76	88.57	94.00	-5.43	Average
2	2441.00	26.33	86.41	7.48	28.76	96.32	114.00	-17.68	Peak
3	4882.00	27.53	27.66	12.14	33.11	45.38	74.00	-28.62	Peak
4	6780.00	27.86	21.67	16.60	36.62	47.03	74.00	-26.97	Peak
5	9500.00	28.60	20.36	16.92	38.00	46.68	74.00	-27.32	Peak
6	13240.00	29.25	16.33	18.48	41.81	47.37	74.00	-26.63	Peak
7	13920.00	29.38	14.73	19.27	43.42	48.04	74.00	-25.96	Peak



EUT :	7.9 inch tablet	Model Name :	EGQ178
Temperature :	26 °C	Relative Humidity :	54%
Pressure :	1010 hPa	Test Voltage :	DC 3.7V
Test Mode :	TX 2480MHz – CH 78(1Mbps)	Polarization :	Horizontal

Remark:
Factor = Antenna Factor + Cable Loss – Pre-amplifier.

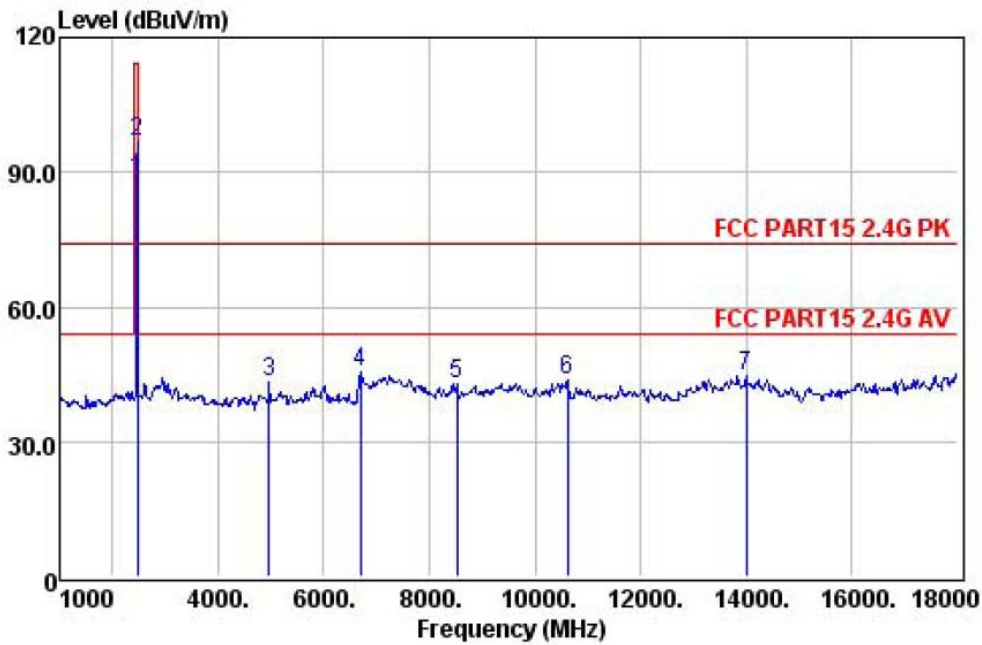

	Preamp	Read	Cable	Antenna	Limit	Over		
	Freq	Factor	Level	Loss	Factor	Line	Limit	Remark
	MHz	dB	dBuV	dB	dB/m	dBuV/m	dBuV/m	dB
1	2480.00	26.34	78.47	7.57	28.79	88.49	94.00	-5.51 Average
2	2480.00	26.34	86.58	7.57	28.79	96.60	114.00	-17.40 Peak
3	4960.00	27.58	25.22	12.36	33.32	43.32	74.00	-30.68 Peak
4	6695.00	27.84	20.37	16.60	36.39	45.52	74.00	-28.48 Peak
5	8514.00	28.25	17.30	16.77	36.82	42.64	74.00	-31.36 Peak
6	10605.00	28.86	16.12	17.09	39.26	43.61	74.00	-30.39 Peak
7	14005.00	29.40	11.33	19.37	43.50	44.80	74.00	-29.20 Peak



EUT :	7.9 inch tablet	Model Name :	EGQ178
Temperature :	26 °C	Relative Humidity :	54%
Pressure :	1010 hPa	Test Voltage :	DC 3.7V
Test Mode :	TX 2480MHz – CH 78(1Mbps)	Polarization :	Vertical

Remark:
Factor = Antenna Factor + Cable Loss – Pre-amplifier.

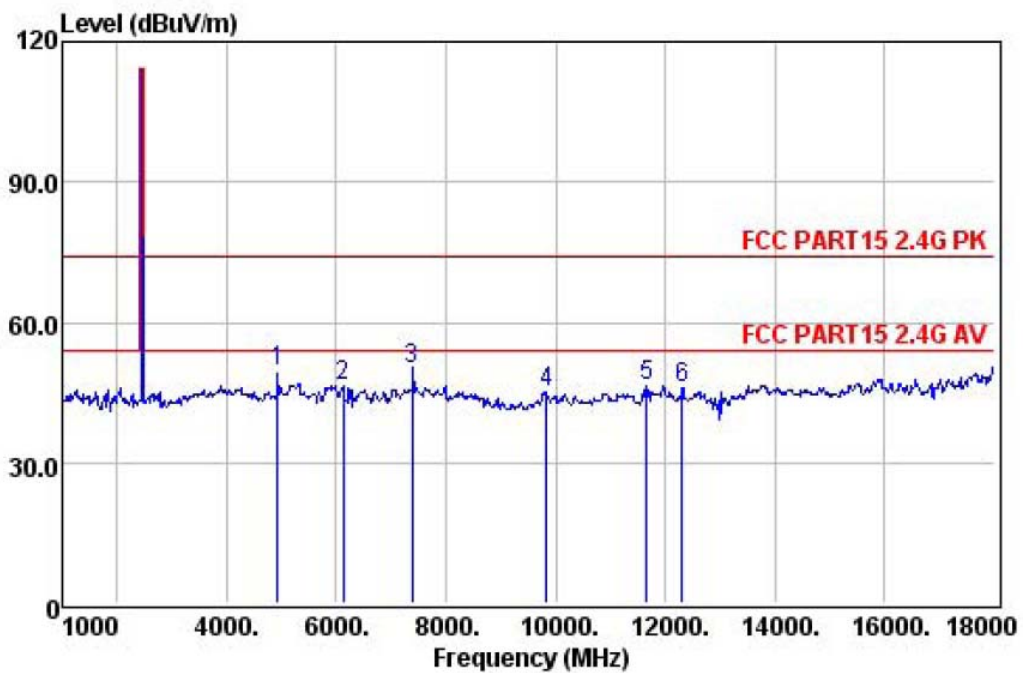

	Preamp Freq	Preamp Factor	Read Level	Cable Loss	Antenna Factor	Limit Level	Over Limit	Remark
	MHz	dB	dBuV	dB	dB/m	dBuV/m	dBuV/m	dB
1	4924.00	27.56	31.73	12.28	33.23	49.68	74.00	-24.32 Peak
2	6117.00	27.72	22.25	16.60	35.36	46.49	74.00	-27.51 Peak
3	7386.00	27.98	23.97	16.62	37.36	49.97	74.00	-24.03 Peak
4	9840.00	28.74	18.56	16.95	38.28	45.05	74.00	-28.95 Peak
5	11659.00	28.97	18.23	17.30	39.74	46.30	74.00	-27.70 Peak
6	12305.00	29.06	18.07	17.62	39.46	46.09	74.00	-27.91 Peak



EUT :	7.9 inch tablet	Model Name :	EGQ178
Temperature :	26 °C	Relative Humidity :	54%
Pressure :	1010 hPa	Test Voltage :	DC 3.7V
Test Mode :	TX 2402MHz – CH 00(2Mbps)	Polarization :	Horizontal

Remark:
Factor = Antenna Factor + Cable Loss – Pre-amplifier.

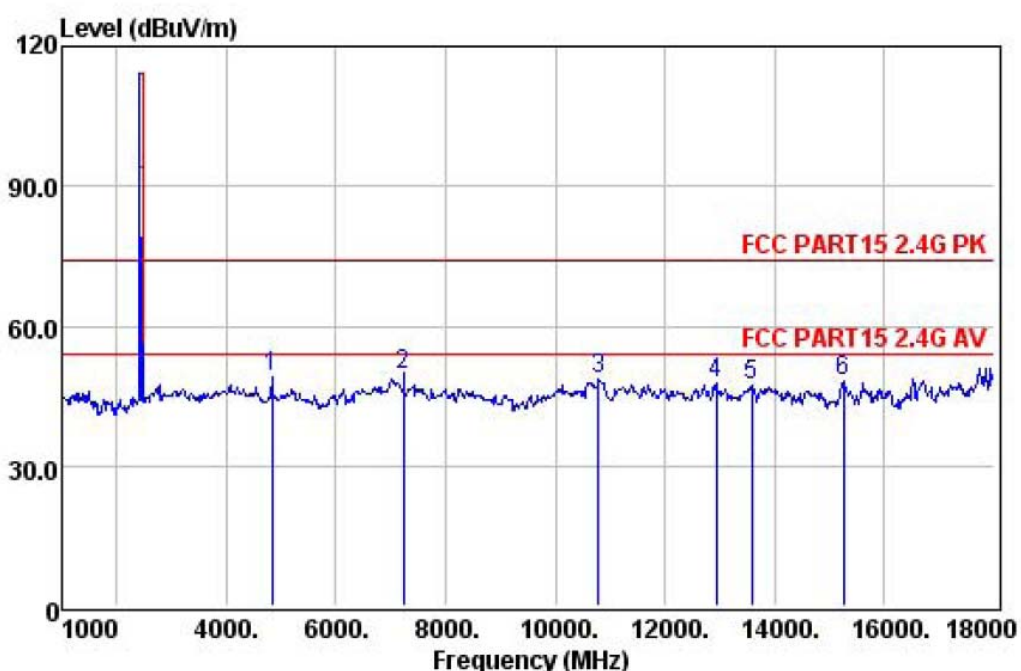

	Preamp	Read	Cable	Antenna		Limit	Over	
	Freq	Factor	Level	Loss	Factor	Level	Line	Limit
	MHz	dB	dBuV	dB	dB/m	dBuV/m	dBuV/m	dB
1	4824.00	27.50	31.46	12.01	32.99	48.96	74.00	-25.04 Peak
2	7236.00	27.95	23.71	16.61	37.30	49.67	74.00	-24.33 Peak
3	10775.00	28.88	20.91	17.12	39.37	48.52	74.00	-25.48 Peak
4	12934.00	29.19	18.07	18.15	40.54	47.57	74.00	-26.43 Peak
5	13580.00	29.32	14.67	18.87	43.08	47.30	74.00	-26.70 Peak
6	15246.00	29.59	18.99	20.16	38.45	48.01	74.00	-25.99 Peak



EUT :	7.9 inch tablet	Model Name :	EGQ178
Temperature :	26 °C	Relative Humidity :	54%
Pressure :	1010 hPa	Test Voltage :	DC 3.7V
Test Mode :	TX 2402MHz – CH 00(2Mbps)	Polarization :	Vertical

Remark:
Factor = Antenna Factor + Cable Loss – Pre-amplifier.

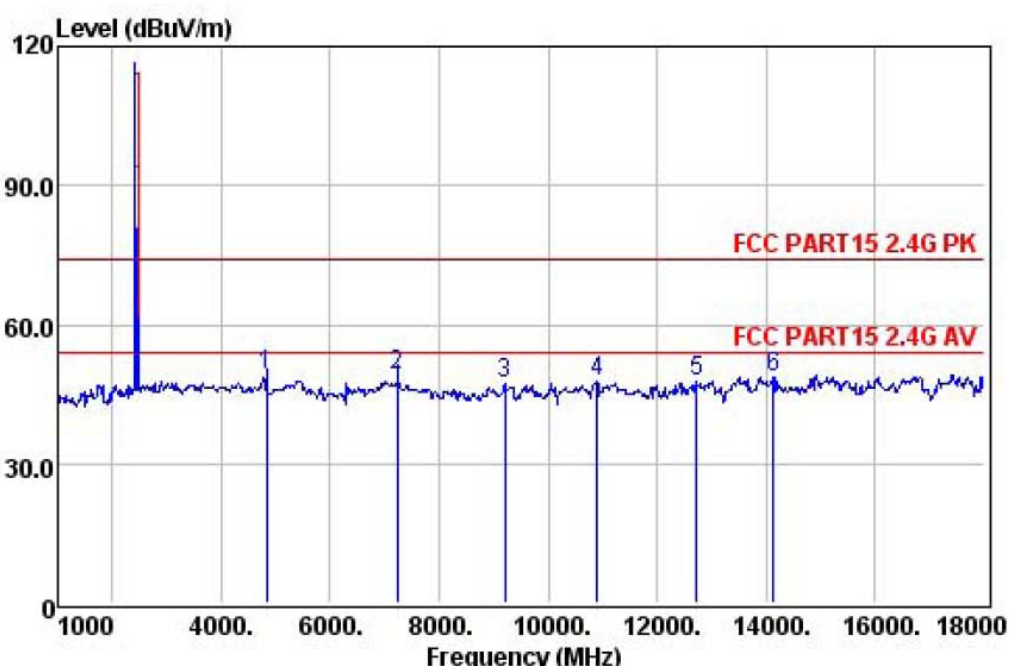

	Preamp Freq	Preamp Factor	Read Level	Cable Loss	Antenna Factor	Limit Line	Over Limit	Remark
	MHz	dB	dBuV	dB	dB/m	dBuV/m	dB	
1	4824.00	27.50	31.44	12.01	32.99	48.94	74.00	-25.06 Peak
2	7236.00	27.95	23.15	16.61	37.30	49.11	74.00	-24.89 Peak
3	9211.00	28.48	20.99	16.90	37.65	47.06	74.00	-26.94 Peak
4	10894.00	28.89	19.82	17.15	39.44	47.52	74.00	-26.48 Peak
5	12730.00	29.15	18.87	17.99	40.06	47.77	74.00	-26.23 Peak
6	14124.00	29.42	15.88	19.44	42.80	48.70	74.00	-25.30 Peak



EUT :	7.9 inch tablet	Model Name :	EGQ178
Temperature :	26 °C	Relative Humidity :	54%
Pressure :	1010 hPa	Test Voltage :	DC 3.7V
Test Mode :	TX 2441MHz – CH 39(2Mbps)	Polarization :	Horizontal

Remark:
Factor = Antenna Factor + Cable Loss – Pre-amplifier.

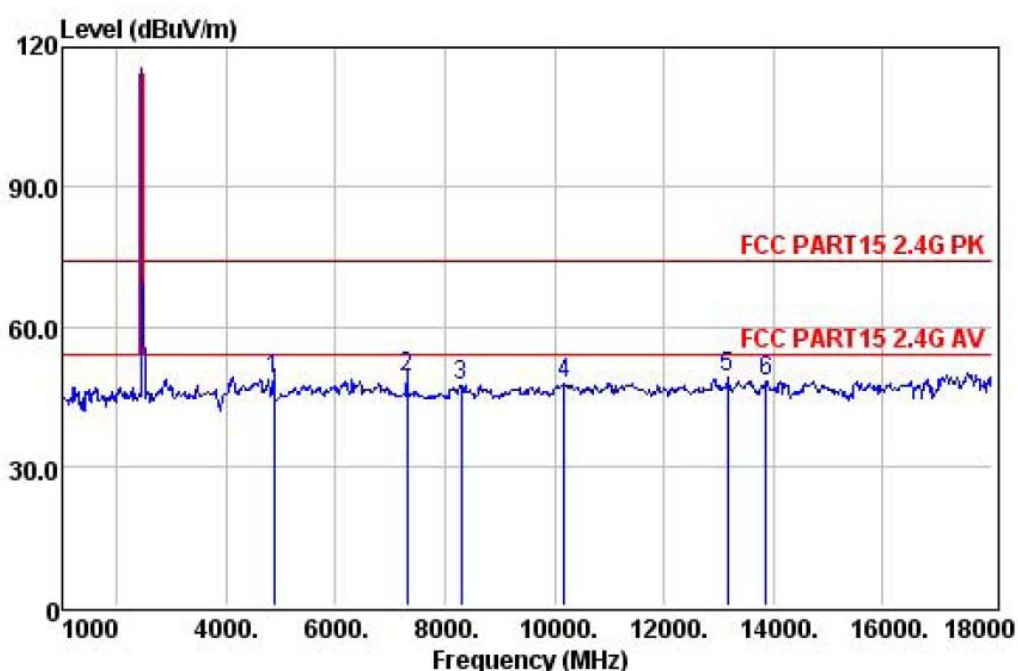

	Preamp	Read	Cable	Antenna		Limit	Over	
	Freq	Factor	Level	Loss	Factor	Line	Limit	Remark
	MHz	dB	dBuV	dB	dB/m	dBuV/m	dBuV/m	dB
1	4874.00	27.53	30.85	12.14	33.11	48.57	74.00	-25.43 Peak
2	7311.00	27.96	23.10	16.62	37.32	49.08	74.00	-24.92 Peak
3	8293.00	28.19	22.28	16.72	36.63	47.44	74.00	-26.56 Peak
4	10180.00	28.82	20.99	17.00	38.69	47.86	74.00	-26.14 Peak
5	13155.00	29.23	18.63	18.40	41.41	49.21	74.00	-24.79 Peak
6	13869.00	29.37	15.19	19.20	43.37	48.39	74.00	-25.61 Peak



EUT :	7.9 inch tablet	Model Name :	EGQ178
Temperature :	26 °C	Relative Humidity :	54%
Pressure :	1010 hPa	Test Voltage :	DC 3.7V
Test Mode :	TX 2441MHz – CH 39(2Mbps)	Polarization :	Vertical

Remark:
Factor = Antenna Factor + Cable Loss – Pre-amplifier.

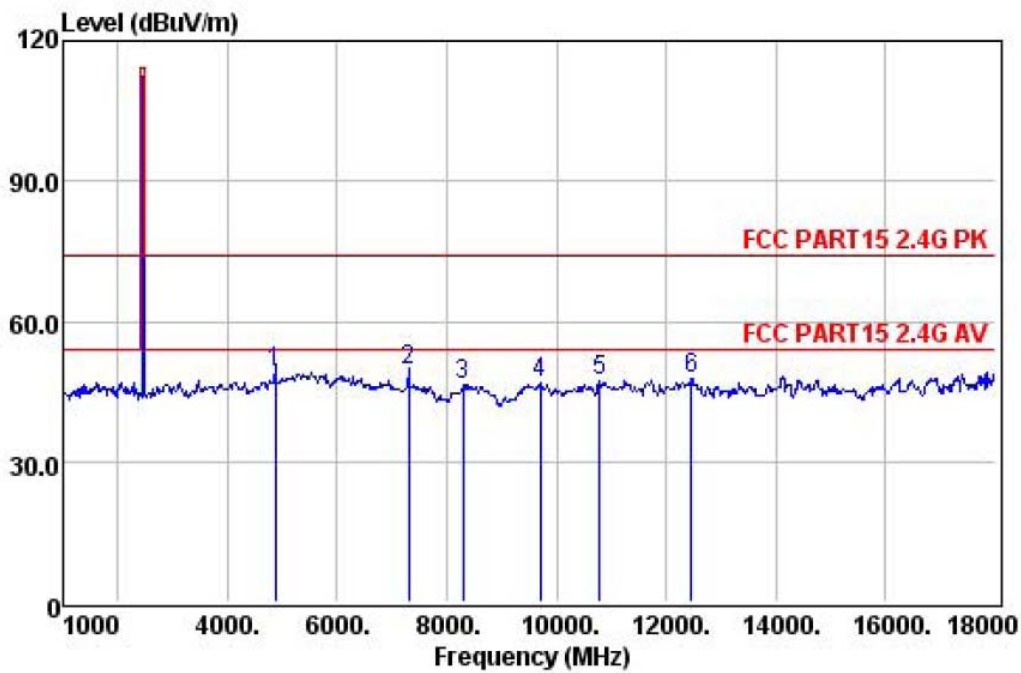

	Preamp	Read	CableAntenna	Limit	Over			
Freq	Factor	Level	Loss	Factor	Level	Line	Limit	Remark
MHz	dB	dBuV	dB	dB/m	dBuV/m	dBuV/m	dB	
1	4874.00	27.53	31.39	12.14	33.11	49.11	74.00	-24.89 Peak
2	7311.00	27.96	23.69	16.62	37.32	49.67	74.00	-24.33 Peak
3	8293.00	28.19	21.28	16.72	36.63	46.44	74.00	-27.56 Peak
4	9704.00	28.68	20.32	16.94	38.17	46.75	74.00	-27.25 Peak
5	10775.00	28.88	19.49	17.12	39.37	47.10	74.00	-26.90 Peak
6	12458.00	29.09	19.73	17.76	39.49	47.89	74.00	-26.11 Peak



EUT :	7.9 inch tablet	Model Name :	EGQ178
Temperature :	26 °C	Relative Humidity :	54%
Pressure :	1010 hPa	Test Voltage :	DC 3.7V
Test Mode :	TX 2480MHz – CH 78(2Mbps)	Polarization :	Horizontal

Remark:
Factor = Antenna Factor + Cable Loss – Pre-amplifier.

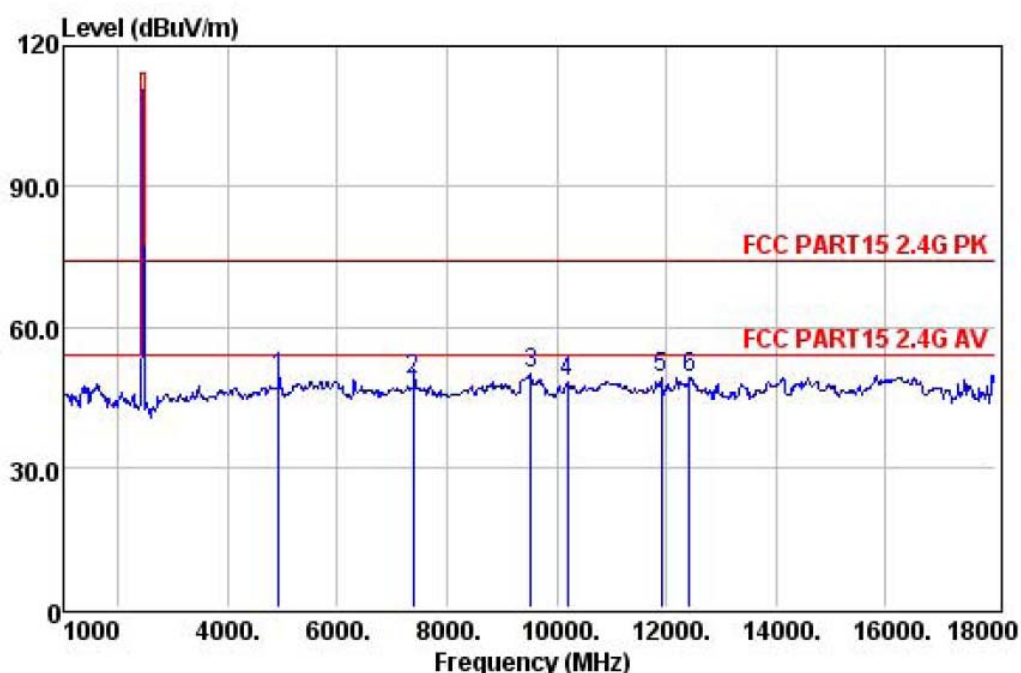

	Preamp Freq	Factor	Read Level	Cable Loss	Antenna Factor	Limit Line	Over Limit	Remark
	MHz	dB	dBuV	dB	dB/m	dBuV/m	dB	
1	4924.00	27.56	30.94	12.28	33.23	48.89	74.00	-25.11 Peak
2	7386.00	27.98	22.68	16.62	37.36	48.68	74.00	-25.32 Peak
3	9534.00	28.61	23.59	16.92	38.03	49.93	74.00	-24.07 Peak
4	10197.00	28.82	21.37	17.00	38.72	48.27	74.00	-25.73 Peak
5	11914.00	28.99	21.22	17.35	39.49	49.07	74.00	-24.93 Peak
6	12424.00	29.08	20.83	17.73	39.49	48.97	74.00	-25.03 Peak



EUT :	7.9 inch tablet	Model Name :	EGQ178
Temperature :	26 °C	Relative Humidity :	54%
Pressure :	1010 hPa	Test Voltage :	DC 3.7V
Test Mode :	TX 2480MHz – CH 78(2Mbps)	Polarization :	Vertical

Remark:
Factor = Antenna Factor + Cable Loss – Pre-amplifier.

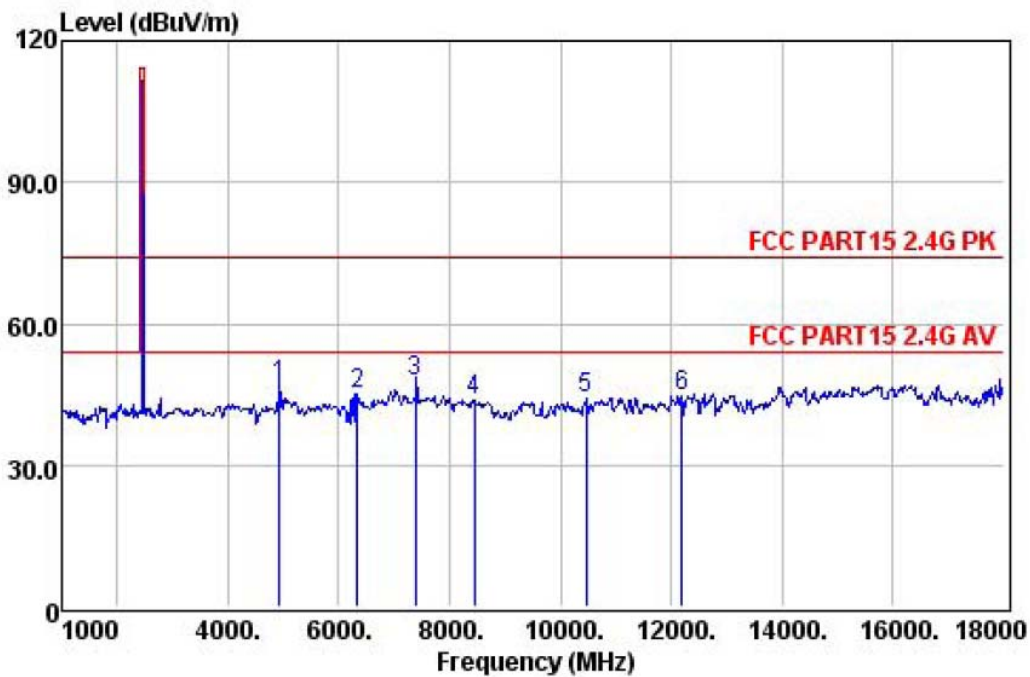

	Preamp Freq	Preamp Factor	Read Level	Cable Loss	Antenna Factor	Level	Limit Line	Over Limit	Remark
	MHz	dB	dBuV	dB	dB/m	dBuV/m	dBuV/m	dB	
1	4924.00	27.56	29.02	12.28	33.23	46.97	74.00	-27.03	Peak
2	6338.00	27.77	20.69	16.60	35.67	45.19	74.00	-28.81	Peak
3	7386.00	27.98	21.87	16.62	37.36	47.87	74.00	-26.13	Peak
4	8446.00	28.23	18.61	16.76	36.76	43.90	74.00	-30.10	Peak
5	10469.00	28.85	17.00	17.06	39.15	44.36	74.00	-29.64	Peak
6	12186.00	29.04	16.78	17.53	39.44	44.71	74.00	-29.29	Peak



EUT :	7.9 inch tablet	Model Name :	EGQ178
Temperature :	26 °C	Relative Humidity :	54%
Pressure :	1010 hPa	Test Voltage :	DC 3.7V
Test Mode :	TX 2402MHz – CH00 (3Mbps)	Polarization :	Horizontal

Remark:
Factor = Antenna Factor + Cable Loss – Pre-amplifier.

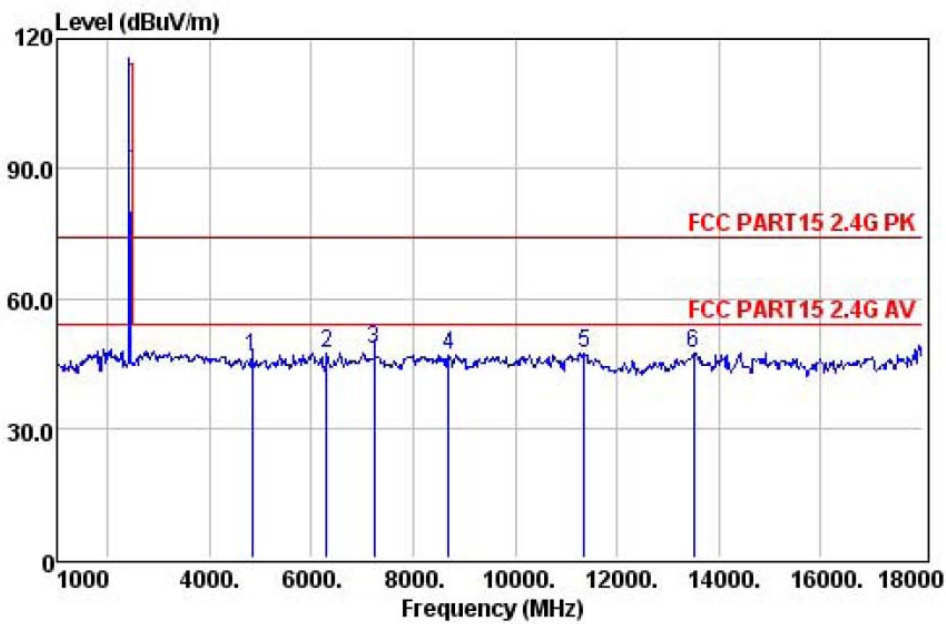

	Preamp Freq	Preamp Factor	Read Level	Cable Loss	Antenna Factor	Level	Limit Line	Over Limit	Remark
	MHz	dB	dBuV	dB	dB/m	dBuV/m	dBuV/m	dB	
1	4824.00	27.50	28.81	12.01	32.99	46.31	74.00	-27.69	Peak
2	6287.00	27.76	22.90	16.60	35.60	47.34	74.00	-26.66	Peak
3	7236.00	27.95	22.35	16.61	37.30	48.31	74.00	-25.69	Peak
4	8684.00	28.30	21.34	16.81	37.02	46.87	74.00	-27.13	Peak
5	11353.00	28.94	19.08	17.24	39.78	47.16	74.00	-26.84	Peak
6	13512.00	29.30	14.98	18.79	43.02	47.49	74.00	-26.51	Peak



EUT :	7.9 inch tablet	Model Name :	EGQ178
Temperature :	26 °C	Relative Humidity :	54%
Pressure :	1010 hPa	Test Voltage :	DC 3.7V
Test Mode :	TX 2402MHz – CH00 (3Mbps)	Polarization :	Vertical

Remark:
Factor = Antenna Factor + Cable Loss – Pre-amplifier.

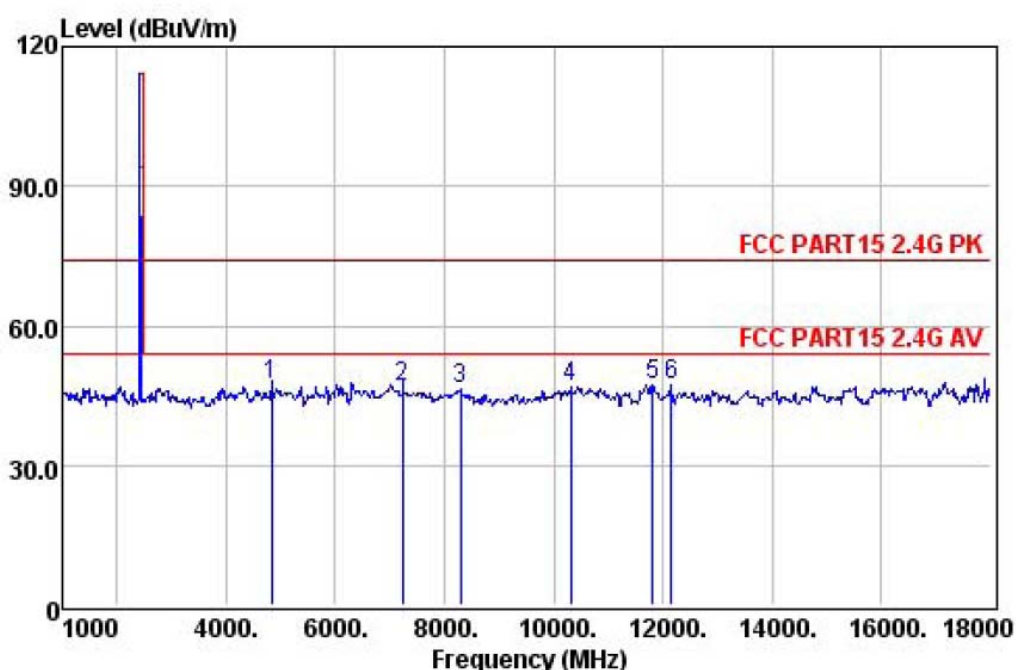

	Preamp Freq	Preamp Factor	Read Level	Cable Loss	Antenna Factor	Limit Level	Over Limit	Remark
	MHz	dB	dBuV	dB	dB/m	dBuV/m	dBuV/m	dB
1	4824.00	27.50	29.66	12.01	32.99	47.16	74.00	-26.84 Peak
2	7236.00	27.95	20.91	16.61	37.30	46.87	74.00	-27.13 Peak
3	8293.00	28.19	21.10	16.72	36.63	46.26	74.00	-27.74 Peak
4	10316.00	28.83	19.57	17.03	38.91	46.68	74.00	-27.32 Peak
5	11812.00	28.98	19.28	17.33	39.59	47.22	74.00	-26.78 Peak
6	12152.00	29.03	19.17	17.50	39.43	47.07	74.00	-26.93 Peak



EUT :	7.9 inch tablet	Model Name :	EGQ178
Temperature :	26 °C	Relative Humidity :	54%
Pressure :	1010 hPa	Test Voltage :	DC 3.7V
Test Mode :	TX 2441MHz – CH39(3Mbps)	Polarization :	Horizontal

Remark:
Factor = Antenna Factor + Cable Loss – Pre-amplifier.

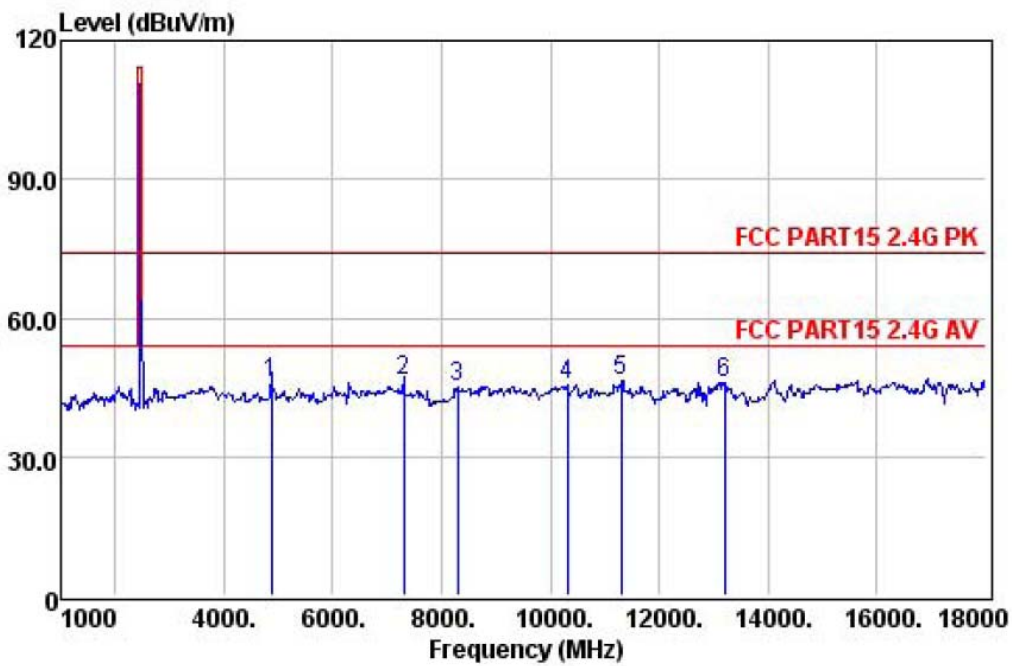

	Preamp Freq	Preamp Factor	Read Level	Cable Loss	Antenna Factor	Level	Limit Line	Over Limit	Remark
	MHz	dB	dBuV	dB	dB/m	dBuV/m	dBuV/m	dB	
1	4874.00	27.53	28.17	12.14	33.11	45.89	74.00	-28.11	Peak
2	7311.00	27.96	20.36	16.62	37.32	46.34	74.00	-27.66	Peak
3	8293.00	28.19	20.10	16.72	36.63	45.26	74.00	-28.74	Peak
4	10316.00	28.83	18.57	17.03	38.91	45.68	74.00	-28.32	Peak
5	11302.00	28.93	18.26	17.22	39.74	46.29	74.00	-27.71	Peak
6	13206.00	29.24	15.22	18.44	41.65	46.07	74.00	-27.93	Peak



EUT :	7.9 inch tablet	Model Name :	EGQ178
Temperature :	26 °C	Relative Humidity :	54%
Pressure :	1010 hPa	Test Voltage :	DC 3.7V
Test Mode :	TX 2441MHz – CH39 (3Mbps)	Polarization :	Vertical

Remark:
Factor = Antenna Factor + Cable Loss – Pre-amplifier.

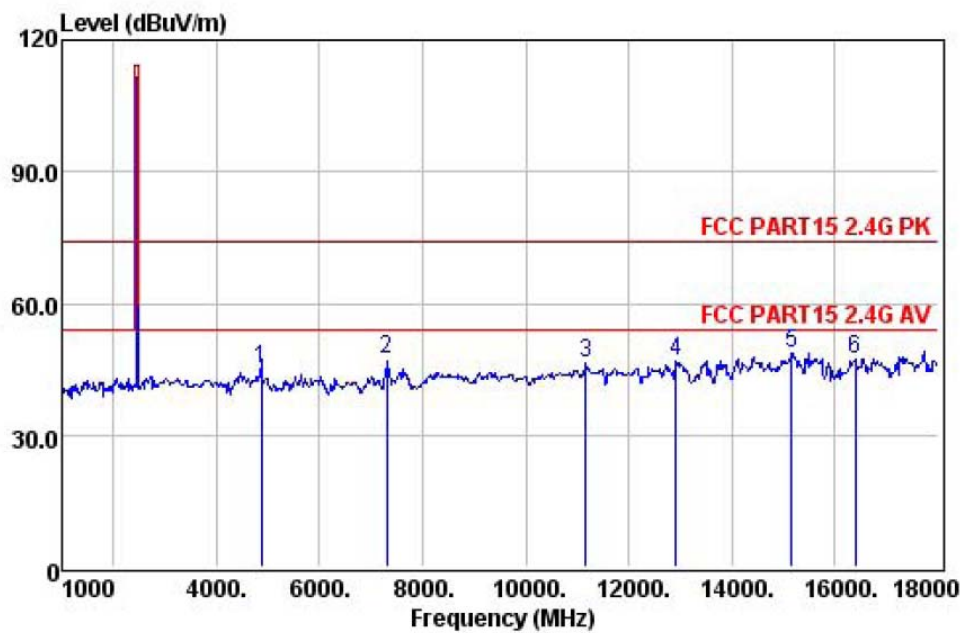

	Preamp	Read	Cable	Antenna	Limit	Over		
Freq	Factor	Level	Loss	Factor	Line	Limit	Remark	
MHz	dB	dBuV	dB	dB/m	dBuV/m	dBuV/m	dB	
1	4874.00	27.53	27.15	12.14	33.11	44.87	74.00	-29.13 Peak
2	7311.00	27.96	21.38	16.62	37.32	47.36	74.00	-26.64 Peak
3	11166.00	28.92	18.45	17.20	39.63	46.36	74.00	-27.64 Peak
4	12917.00	29.18	17.52	18.14	40.50	46.98	74.00	-27.02 Peak
5	15161.00	29.57	19.75	20.10	38.47	48.75	74.00	-25.25 Peak
6	16402.00	29.86	13.67	20.91	42.78	47.50	74.00	-26.50 Peak



EUT :	7.9 inch tablet	Model Name :	EGQ178
Temperature :	26 °C	Relative Humidity :	54%
Pressure :	1010 hPa	Test Voltage :	DC 3.7V
Test Mode :	TX 2480MHz – CH78 (3Mbps)	Polarization :	Horizontal

Remark:
Factor = Antenna Factor + Cable Loss – Pre-amplifier.

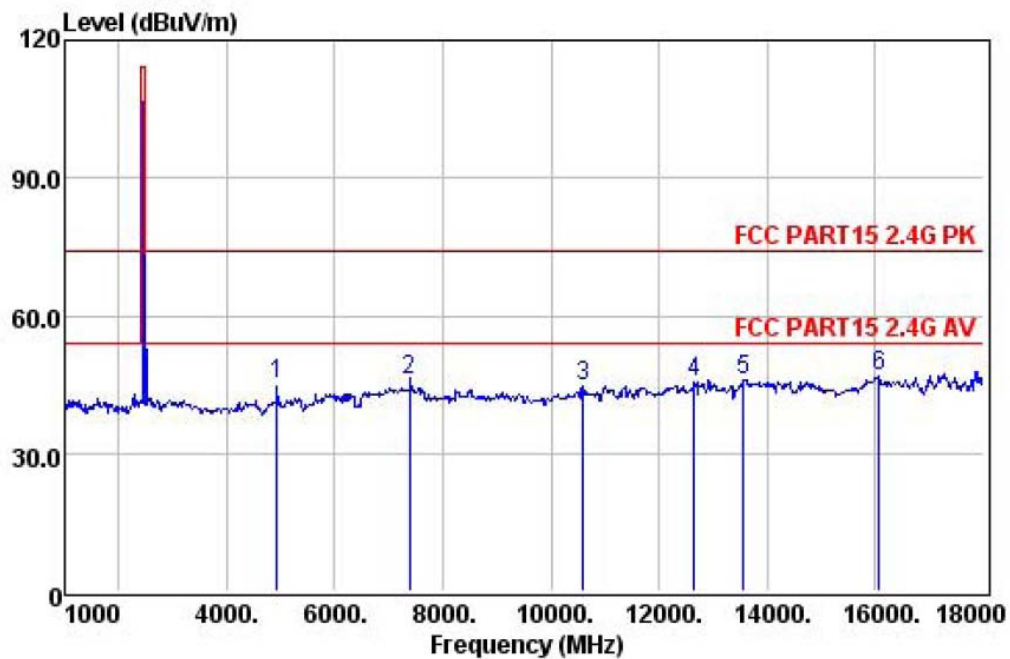

	Preamp	Read	Cable	Antenna		Limit	Over		
	Freq	Factor	Level	Loss	Factor	Level	Line	Limit	Remark
	MHz	dB	dBuV	dB	dB/m	dBuV/m	dBuV/m	dB	
1	4924.00	27.56	27.23	12.28	33.23	45.18	74.00	-28.82	Peak
2	7386.00	27.98	19.84	16.62	37.36	45.84	74.00	-28.16	Peak
3	10588.00	28.86	17.31	17.08	39.25	44.78	74.00	-29.22	Peak
4	12645.00	29.13	16.65	17.91	39.86	45.29	74.00	-28.71	Peak
5	13563.00	29.31	13.56	18.85	43.07	46.17	74.00	-27.83	Peak
6	16079.00	29.73	15.03	20.69	40.82	46.81	74.00	-27.19	Peak



EUT :	7.9 inch tablet	Model Name :	EGQ178
Temperature :	26 °C	Relative Humidity :	54%
Pressure :	1010 hPa	Test Voltage :	DC 3.7V
Test Mode :	TX 2480MHz – CH78 (3Mbps)	Polarization :	Vertical

Remark:
Factor = Antenna Factor + Cable Loss – Pre-amplifier.

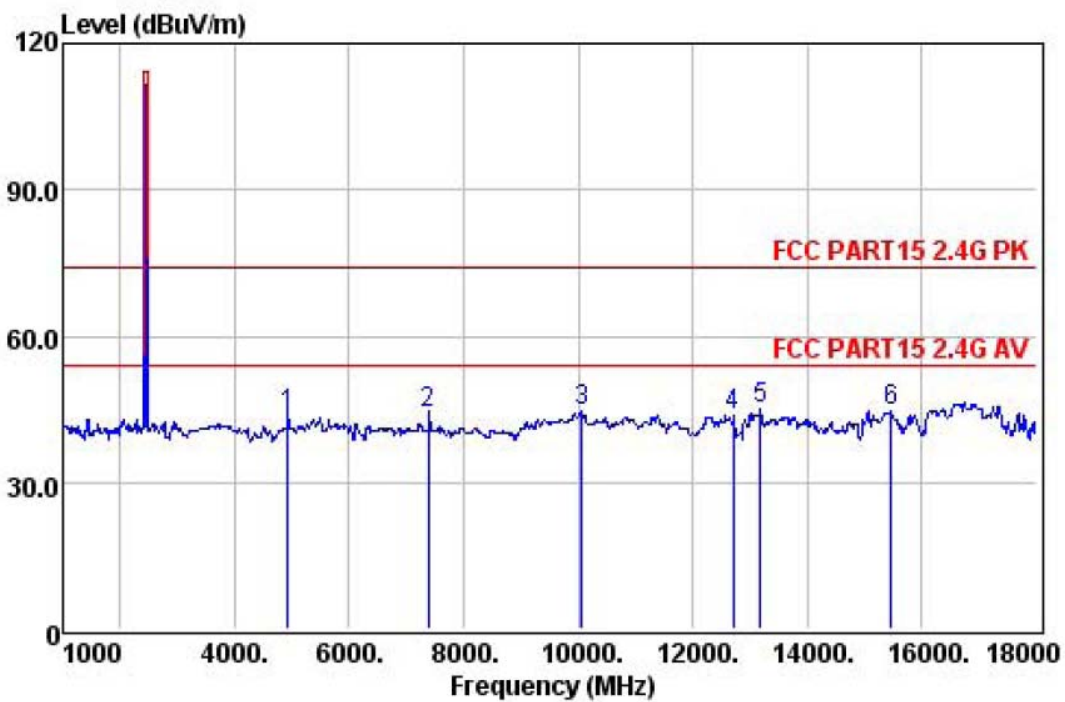

	Preamp Freq	Preamp Factor	Read Level	Cable Loss	Antenna Factor	Level	Limit Line	Over Limit	Remark
	MHz	dB	dBuV	dB	dB/m	dBuV/m	dBuV/m	dB	
1	4924.00	27.56	25.87	12.28	33.23	43.82	74.00	-30.18	Peak
2	7386.00	27.98	18.37	16.62	37.36	44.37	74.00	-29.63	Peak
3	10061.00	28.81	17.77	16.98	38.51	44.45	74.00	-29.55	Peak
4	12713.00	29.14	14.99	17.97	40.02	43.84	74.00	-30.16	Peak
5	13189.00	29.24	14.39	18.42	41.57	45.14	74.00	-28.86	Peak
6	15467.00	29.62	15.54	20.29	38.41	44.62	74.00	-29.38	Peak



3.2.9 TEST RESULTS (RESTRICTED BANDS REQUIREMENTS)

EUT :	7.9 inch tablet	Model Name :	EGQ178
Temperature :	26 °C	Relative Humidity :	54%
Pressure :	1010 hPa	Test Voltage :	DC 3.7V
Test Mode :	TX /2402MHz-1Mbps	Polarization :	Vertical

Frequency (MHz)	Meter Reading (dBµV)	Factor (dB)	Emission Level (dBµV/m)	Limits (dBµV/m)	Margin (dB)	Detector Type
2400	90.6	-40.5	50.1	74	-23.9	peak

Remark:
Factor = Antenna Factor + Cable Loss – Pre-amplifier.

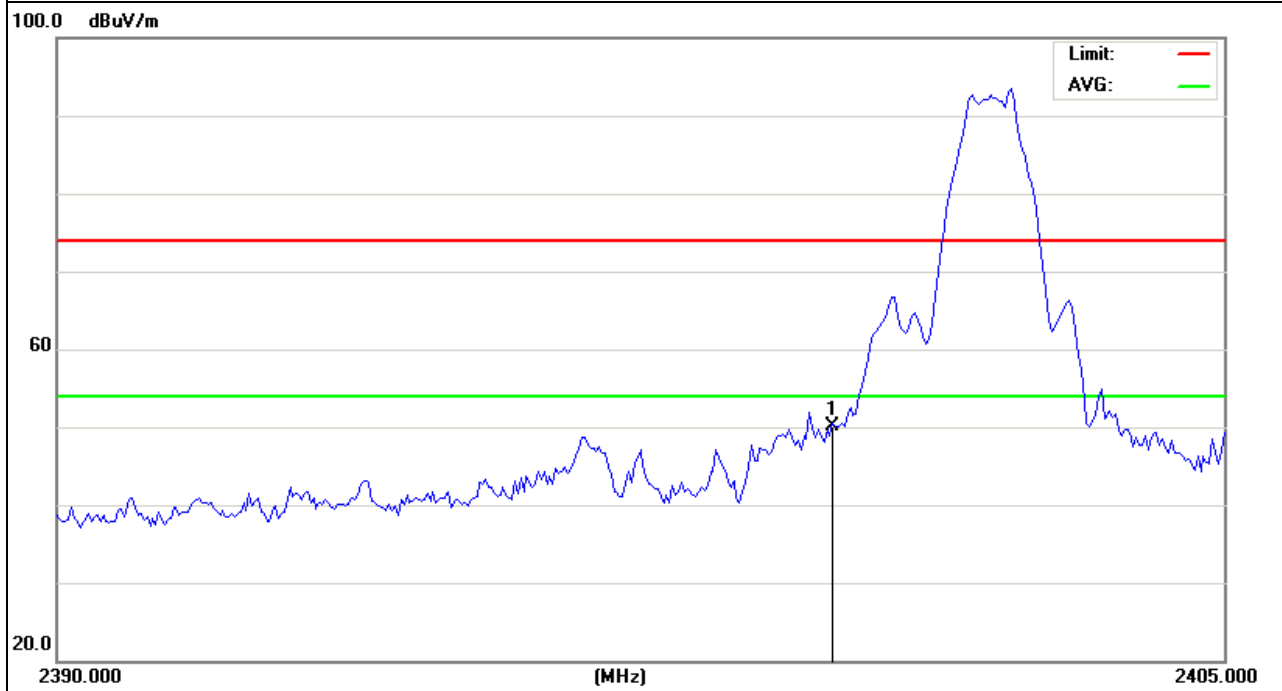



EUT :	7.9 inch tablet	Model Name :	EGQ178
Temperature :	26 °C	Relative Humidity :	54%
Pressure :	1010 hPa	Test Voltage :	DC 3.7V
Test Mode :	TX /2402MHz-1Mbps	Polarization :	Horizontal

Frequency (MHz)	Meter Reading (dBμV)	Factor (dB)	Emission Level (dBμV/m)	Limits (dBμV/m)	Margin (dB)	Detector Type
2400	86	-40.5	45.5	74	-28.5	peak

Remark:
Factor = Antenna Factor + Cable Loss – Pre-amplifier.

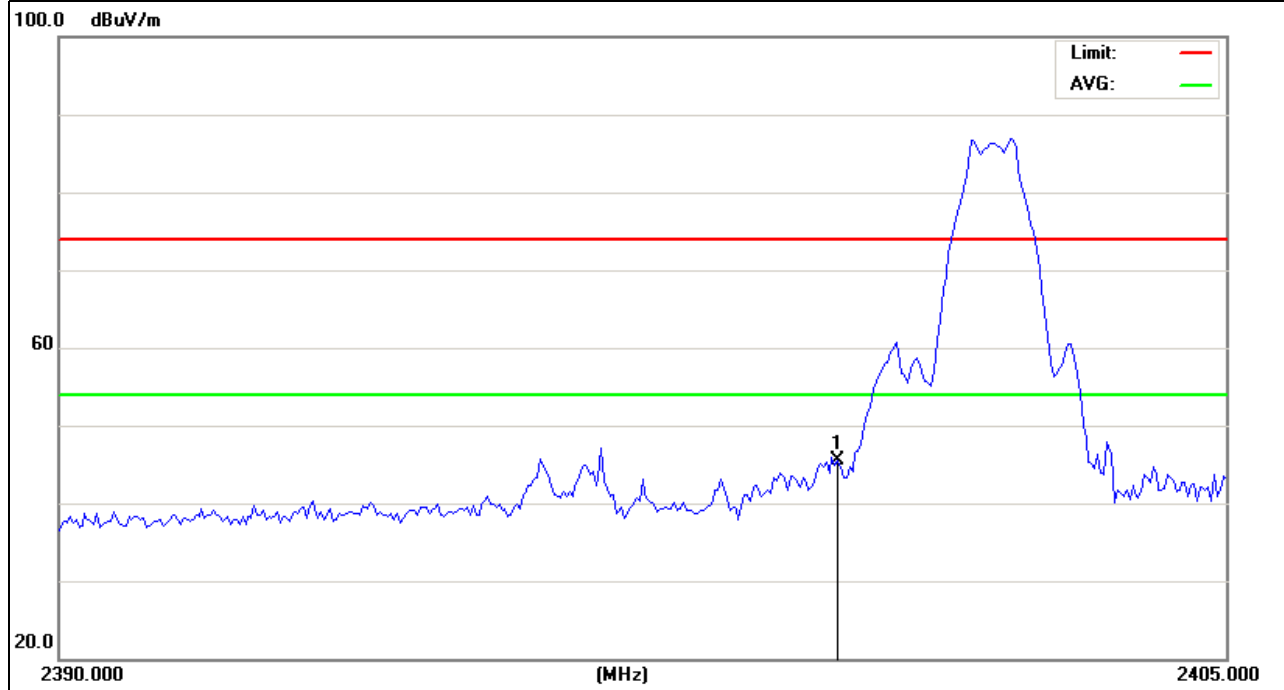



EUT :	7.9 inch tablet	Model Name :	EGQ178
Temperature :	26 °C	Relative Humidity :	54%
Pressure :	1010 hPa	Test Voltage :	DC 3.7V
Test Mode :	TX /2480MHz-1Mbps	Polarization :	Vertical

Frequency (MHz)	Meter Reading (dBμV)	Factor (dB)	Emission Level (dBμV/m)	Limits (dBμV/m)	Margin (dB)	Detector Type
2483.5	84.73	-40.43	44.3	74	-29.7	peak

Remark:
Factor = Antenna Factor + Cable Loss – Pre-amplifier.

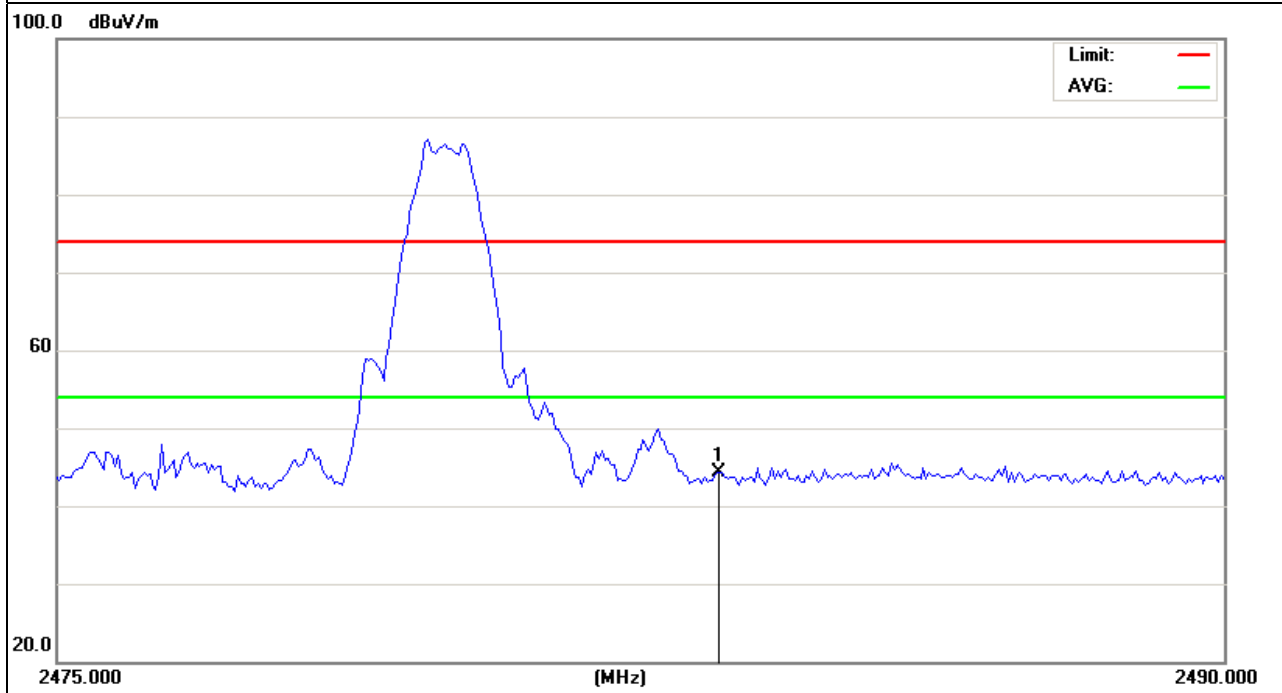



EUT :	7.9 inch tablet	Model Name :	EGQ178
Temperature :	26 °C	Relative Humidity :	54%
Pressure :	1010 hPa	Test Voltage :	DC 3.7V
Test Mode :	TX /2480MHz-1Mbps	Polarization :	Horizontal

Frequency (MHz)	Meter Reading (dBμV)	Factor (dB)	Emission Level (dBμV/m)	Limits (dBμV/m)	Margin (dB)	Detector Type
2483.5	76.93	-40.43	36.5	74	-37.5	peak

Remark:
Factor = Antenna Factor + Cable Loss – Pre-amplifier.

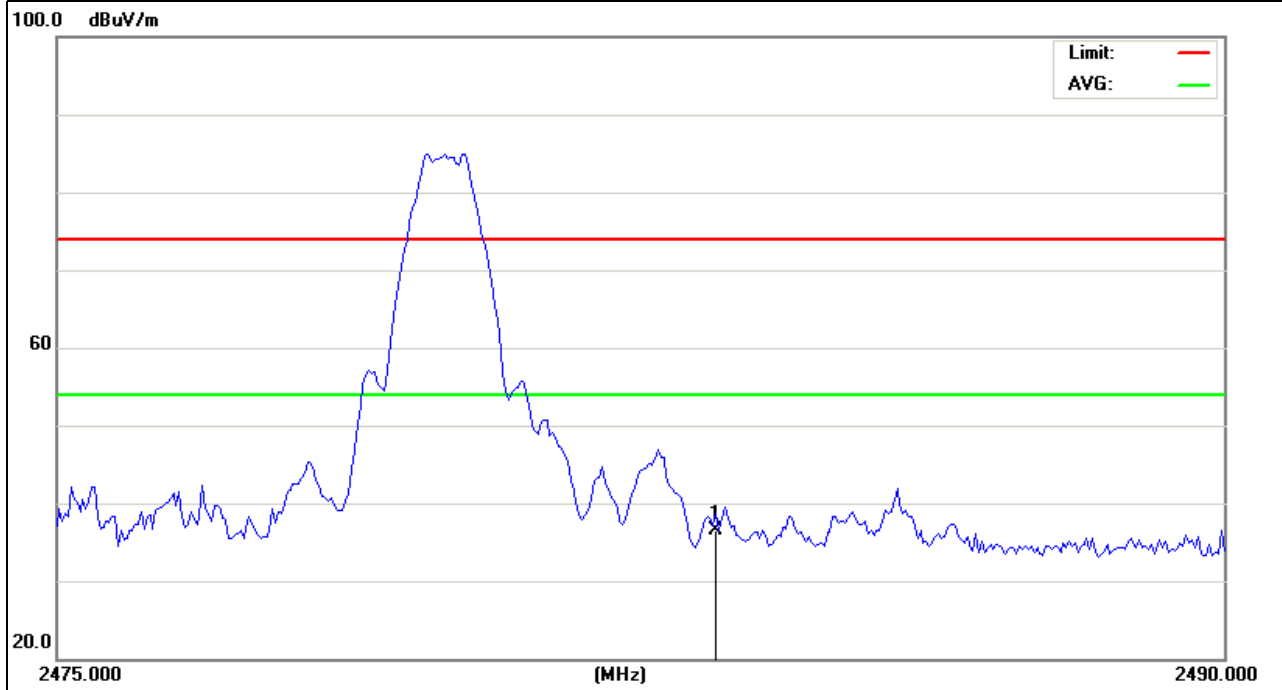



EUT :	7.9 inch tablet	Model Name :	EGQ178
Temperature :	26 °C	Relative Humidity :	54%
Pressure :	1010 hPa	Test Voltage :	DC 3.7V
Test Mode :	TX /2402MHz-2Mbps	Polarization :	Vertical

Frequency (MHz)	Meter Reading (dBμV)	Factor (dB)	Emission Level (dBμV/m)	Limits (dBμV/m)	Margin (dB)	Detector Type
2400	83.9	-40.5	43.4	74	-30.6	peak

Remark:
Factor = Antenna Factor + Cable Loss – Pre-amplifier.

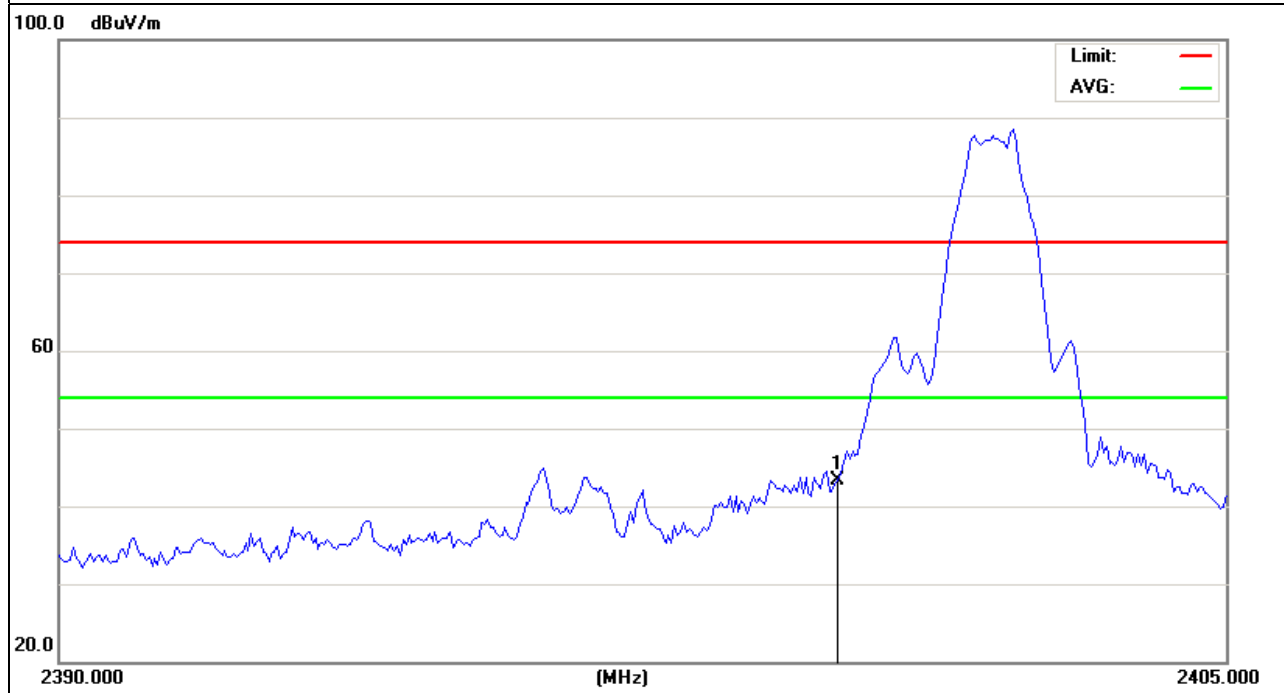



EUT :	7.9 inch tablet	Model Name :	EGQ178
Temperature :	26 °C	Relative Humidity :	54%
Pressure :	1010 hPa	Test Voltage :	DC 3.7V
Test Mode :	TX /2402MHz-2Mbps	Polarization :	Horizontal

Frequency (MHz)	Meter Reading (dBμV)	Factor (dB)	Emission Level (dBμV/m)	Limits (dBμV/m)	Margin (dB)	Detector Type
2400	85.8	-40.5	45.3	74	-28.7	peak

Remark:
Factor = Antenna Factor + Cable Loss – Pre-amplifier.

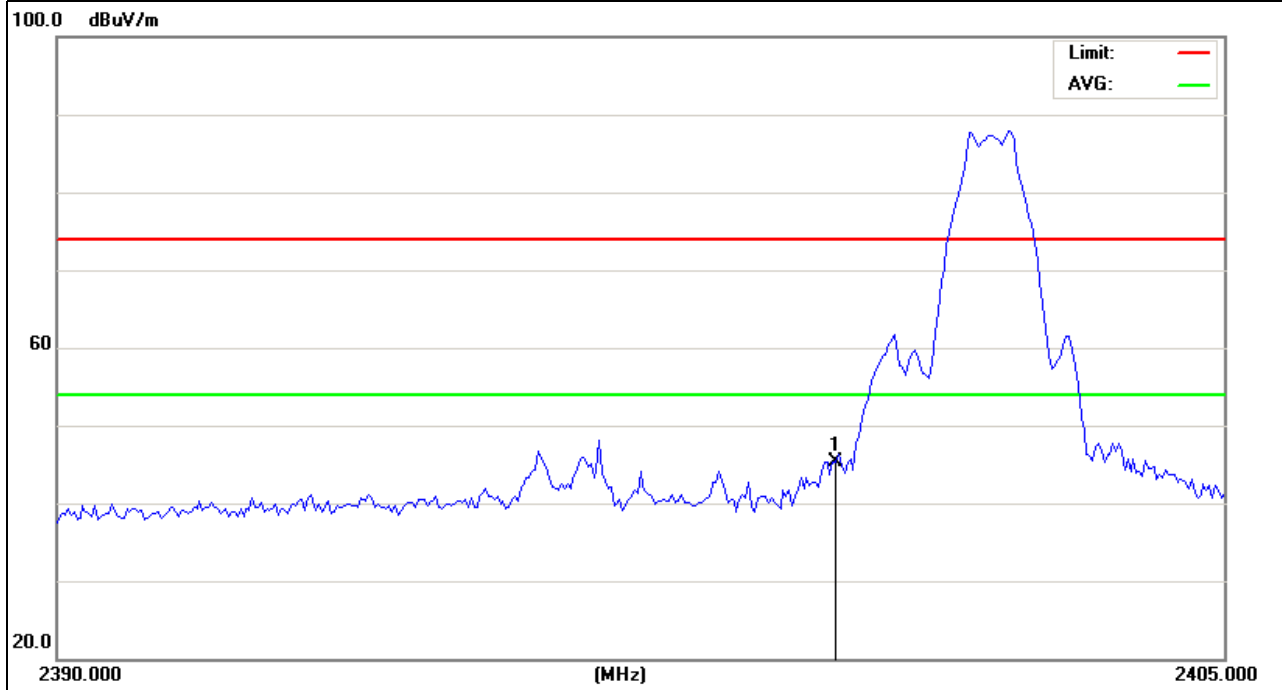



EUT :	7.9 inch tablet	Model Name :	EGQ178
Temperature :	26 °C	Relative Humidity :	54%
Pressure :	1010 hPa	Test Voltage :	DC 3.7V
Test Mode :	TX /2480MHz-2Mbps	Polarization :	Vertical

Frequency (MHz)	Meter Reading (dBμV)	Factor (dB)	Emission Level (dBμV/m)	Limits (dBμV/m)	Margin (dB)	Detector Type
2483.5	83.83	-40.43	43.4	74	-30.6	peak

Remark:
Factor = Antenna Factor + Cable Loss – Pre-amplifier.

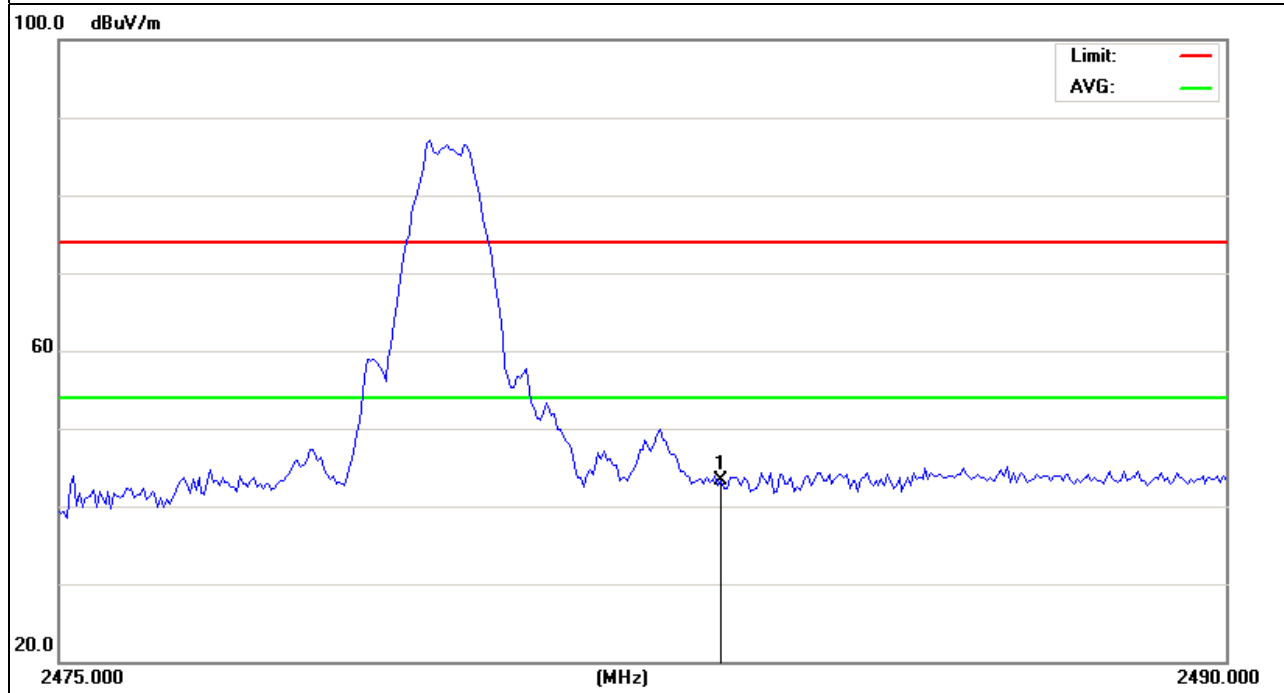



EUT :	7.9 inch tablet	Model Name :	EGQ178
Temperature :	26 °C	Relative Humidity :	54%
Pressure :	1010 hPa	Test Voltage :	DC 3.7V
Test Mode :	TX /2480MHz-2Mbps	Polarization :	Horizontal

Frequency (MHz)	Meter Reading (dBμV)	Factor (dB)	Emission Level (dBμV/m)	Limits (dBμV/m)	Margin (dB)	Detector Type
2483.5	75.73	-40.43	35.3	74	-38.7	peak

Remark:
Factor = Antenna Factor + Cable Loss – Pre-amplifier.

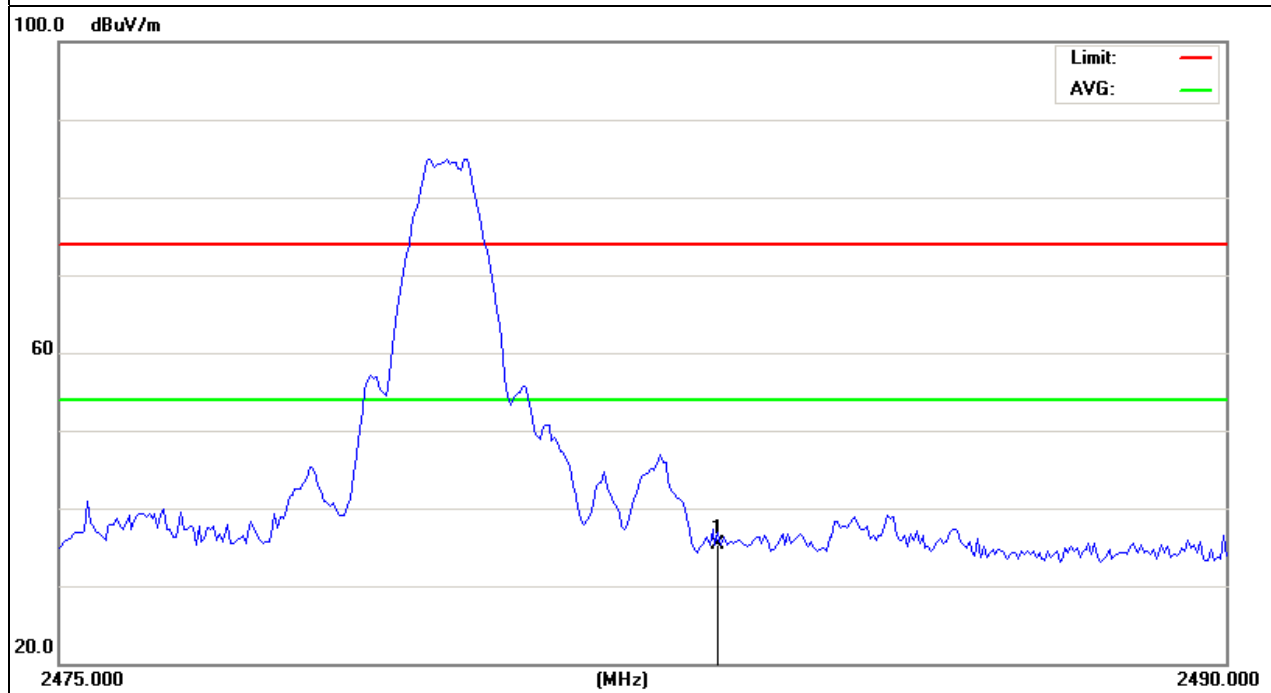



EUT :	7.9 inch tablet	Model Name :	EGQ178
Temperature :	26 °C	Relative Humidity :	54%
Pressure :	1010 hPa	Test Voltage :	DC 3.7V
Test Mode :	TX /2402MHz-3Mbps	Polarization :	Vertical

Frequency (MHz)	Meter Reading (dBμV)	Factor (dB)	Emission Level (dBμV/m)	Limits (dBμV/m)	Margin (dB)	Detector Type
2400	90.2	-40.5	49.7	74	-24.3	peak

Remark:
Factor = Antenna Factor + Cable Loss – Pre-amplifier.

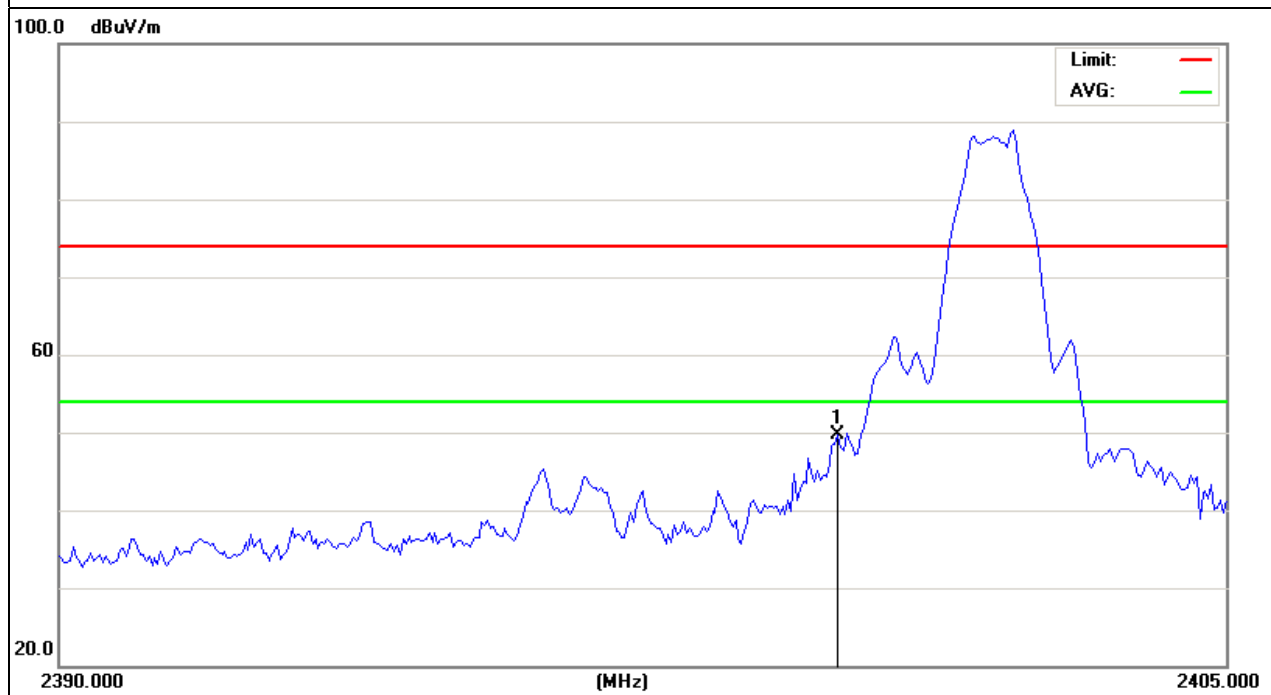



EUT :	7.9 inch tablet	Model Name :	EGQ178
Temperature :	26 °C	Relative Humidity :	54%
Pressure :	1010 hPa	Test Voltage :	DC 3.7V
Test Mode :	TX /2402MHz-3Mbps	Polarization :	Horizontal

Frequency (MHz)	Meter Reading (dBμV)	Factor (dB)	Emission Level (dBμV/m)	Limits (dBμV/m)	Margin (dB)	Detector Type
2400	91	-40.5	50.5	74	-23.5	peak

Remark:
Factor = Antenna Factor + Cable Loss – Pre-amplifier.

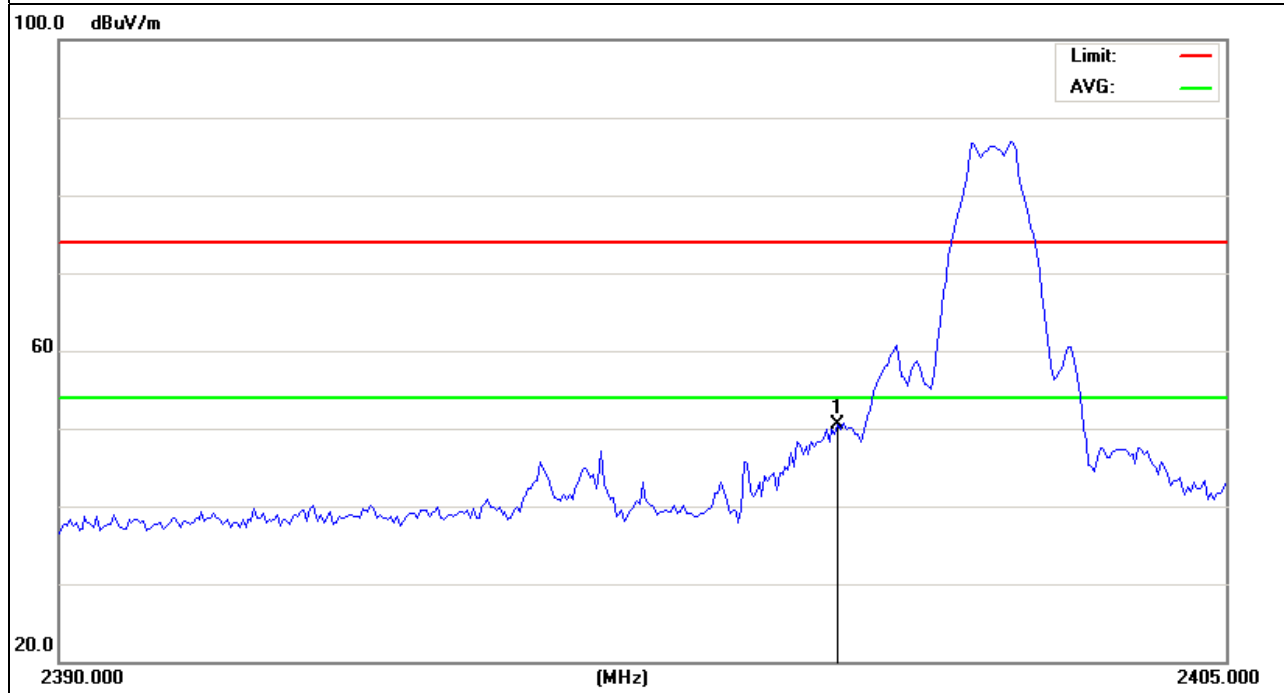



EUT :	7.9 inch tablet	Model Name :	EGQ178
Temperature :	26 °C	Relative Humidity :	54%
Pressure :	1010 hPa	Test Voltage :	DC 3.7V
Test Mode :	TX /2480MHz-3Mbps	Polarization :	Vertical

Frequency (MHz)	Meter Reading (dBμV)	Factor (dB)	Emission Level (dBμV/m)	Limits (dBμV/m)	Margin (dB)	Detector Type
2483.5	81.73	-40.43	41.3	74	-32.7	peak

Remark:
Factor = Antenna Factor + Cable Loss – Pre-amplifier.

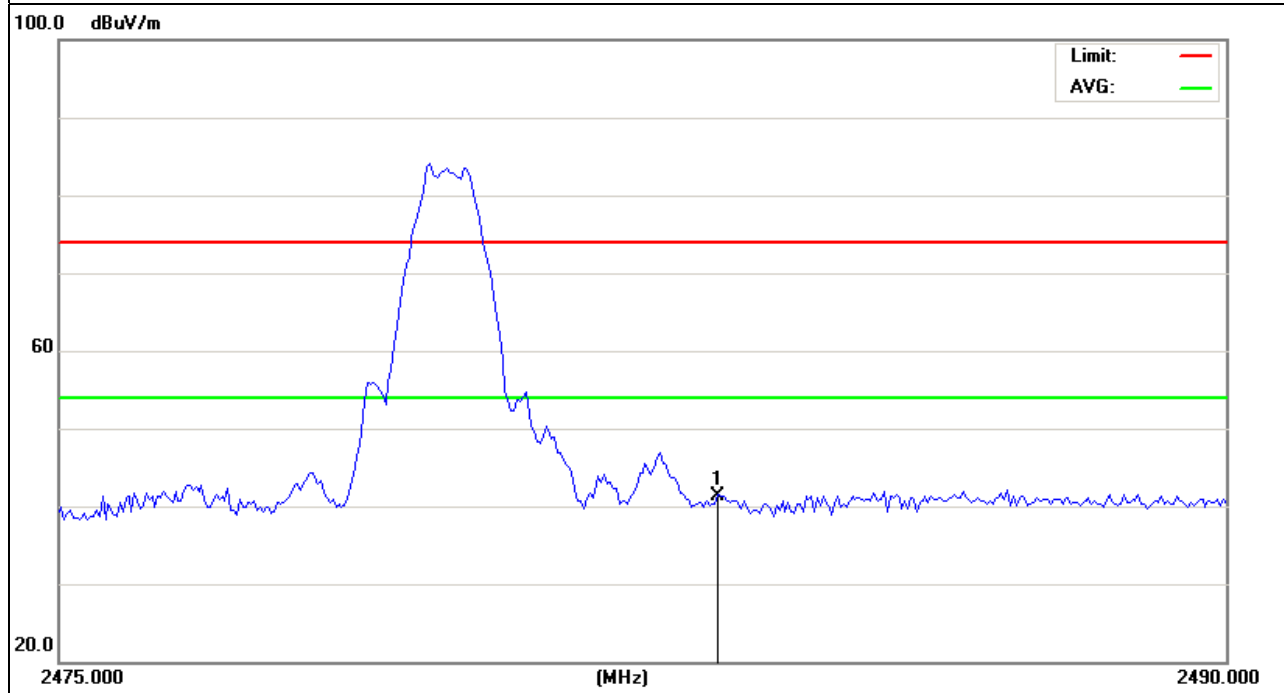



EUT :	7.9 inch tablet	Model Name :	EGQ178
Temperature :	26 °C	Relative Humidity :	54%
Pressure :	1010 hPa	Test Voltage :	DC 3.7V
Test Mode :	TX /2480MHz-3Mbps	Polarization :	Horizontal

Frequency (MHz)	Meter Reading (dBμV)	Factor (dB)	Emission Level (dBμV/m)	Limits (dBμV/m)	Margin (dB)	Detector Type
2483.5	77.93	-40.43	37.5	74	-36.5	peak

Remark:
Factor = Antenna Factor + Cable Loss – Pre-amplifier.

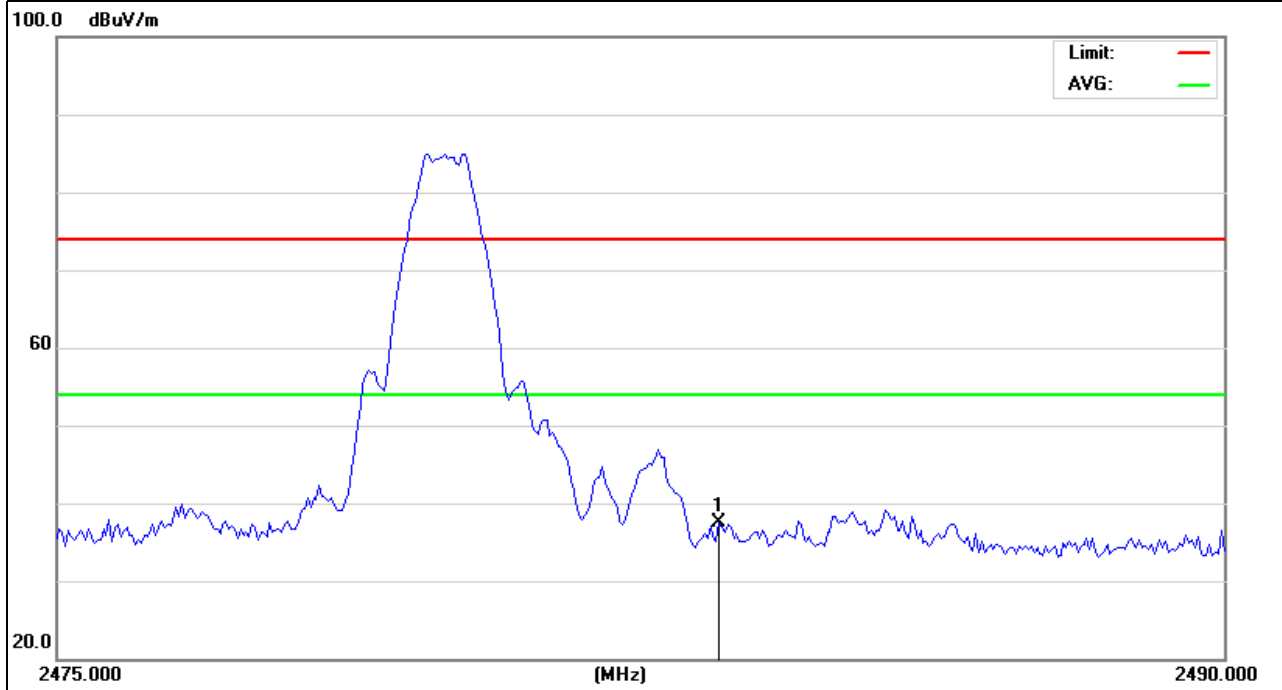

NOTE: Hopping enabled and disabled have evaluated, and the worst data (disabled) was reported



4. NUMBER OF HOPPING CHANNEL

4.1 APPLIED PROCEDURES / LIMIT

FCC Part15 (15.247) , Subpart C				
Section	Test Item	Limit	Frequency Range (MHz)	Result
15.247 (a)(1)(iii)	Number of Hopping Channel	≥15	2400-2483.5	PASS

Spectrum Parameters	Setting
Attenuation	Auto
Span Frequency	> Operating Frequency Range
RB	100 kHz
VB	100 kHz
Detector	Peak
Trace	Max Hold
Sweep Time	Auto

4.1.1 TEST PROCEDURE

- a. The EUT was directly connected to the spectrum analyzer and antenna output port as show in the block diagram below,
- b. Spectrum Setting : RBW= 100KHz, VBW=100KHz, Sweep time = Auto.

4.1.2 DEVIATION FROM STANDARD

No deviation.

4.1.3 TEST SETUP

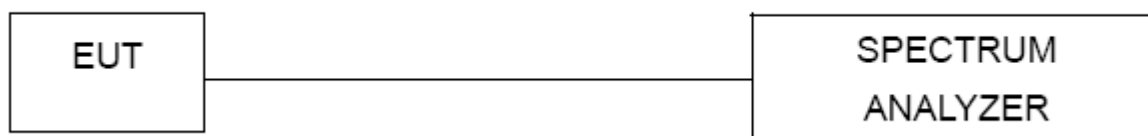

4.1.4 EUT OPERATION CONDITIONS

The EUT tested system was configured as the statements of 2.4 Unless otherwise a special operating condition is specified in the follows during the testing.



4.1.5 TEST RESULTS

EUT :	7.9 inch tablet	Model Name :	EGQ178
Temperature :	26 °C	Relative Humidity :	54%
Pressure :	1015 hPa	Test Voltage :	DC 3.7V
Test Mode :	Hopping Mode		

Number of Hopping Channel	79
---------------------------	----

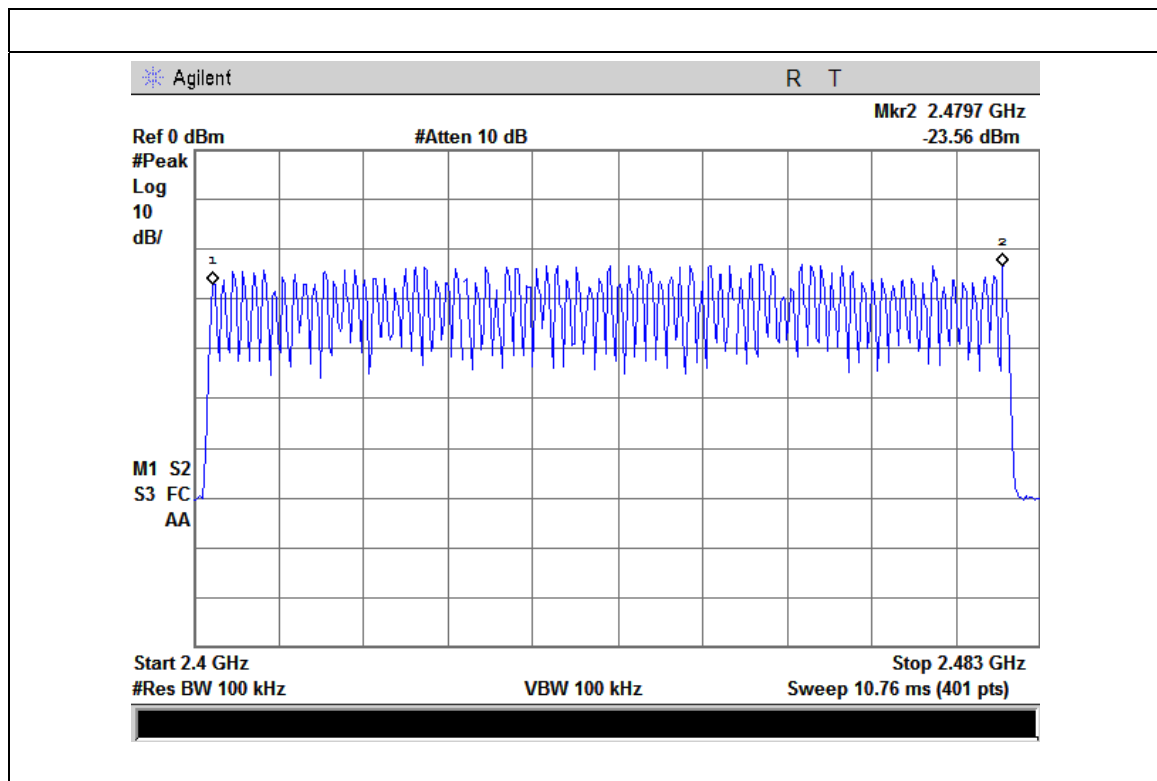



5. AVERAGE TIME OF OCCUPANCY

5.1 APPLIED PROCEDURES / LIMIT

FCC Part15 (15.247) , Subpart C				
Section	Test Item	Limit	Frequency Range (MHz)	Result
15.247 (a)(1)(iii)	Average Time of Occupancy	0.4sec	2400-2483.5	PASS

5.1.1 TEST PROCEDURE

- a. The transmitter output (antenna port) was connected to the spectrum analyzer
- b. Set RBW of spectrum analyzer to 1MHz and VBW to 1MHz.
- c. Use a video trigger with the trigger level set to enable triggering only on full pulses.
- d. Sweep Time is more than once pulse time.
- e. Set the center frequency on any frequency would be measure and set the frequency span to zero span.
- f. Measure the maximum time duration of one single pulse.
- g. Set the EUT for DH5, DH3 and DH1 packet transmitting.
- h. Measure the maximum time duration of one single pulse.
- i. A Period Time = (channel number)*0.4
DH1 Time Slot: Reading * (1600/2)*31.6/(channel number)
DH3 Time Slot: Reading * (1600/4)*31.6/(channel number)
DH5 Time Slot: Reading * (1600/6)*31.6/(channel number)

5.1.2 DEVIATION FROM STANDARD

No deviation.



5.1.3 TEST SETUP



5.1.4 EUT OPERATION CONDITIONS

The EUT tested system was configured as the statements of 2.4 Unless otherwise a special operating condition is specified in the follows during the testing.



5.1.5 TEST RESULTS

EUT :	7.9 inch tablet	Model Name :	EGQ178
Temperature :	26 °C	Relative Humidity :	54%
Pressure :	1012 hPa	Test Voltage :	DC 3.7V
Test Mode :	CH39-DH5 ,2DH5,3DH5		

Data Packet	Frequency	Pulse Duration (ms)	Dwell Time (s)	Limits (s)
DH5	2402 MHz	0.45	0.05	0.4
2DH5	2402 MHz	1.78	0.19	0.4
3DH5	2402 MHz	3.00	0.32	0.4

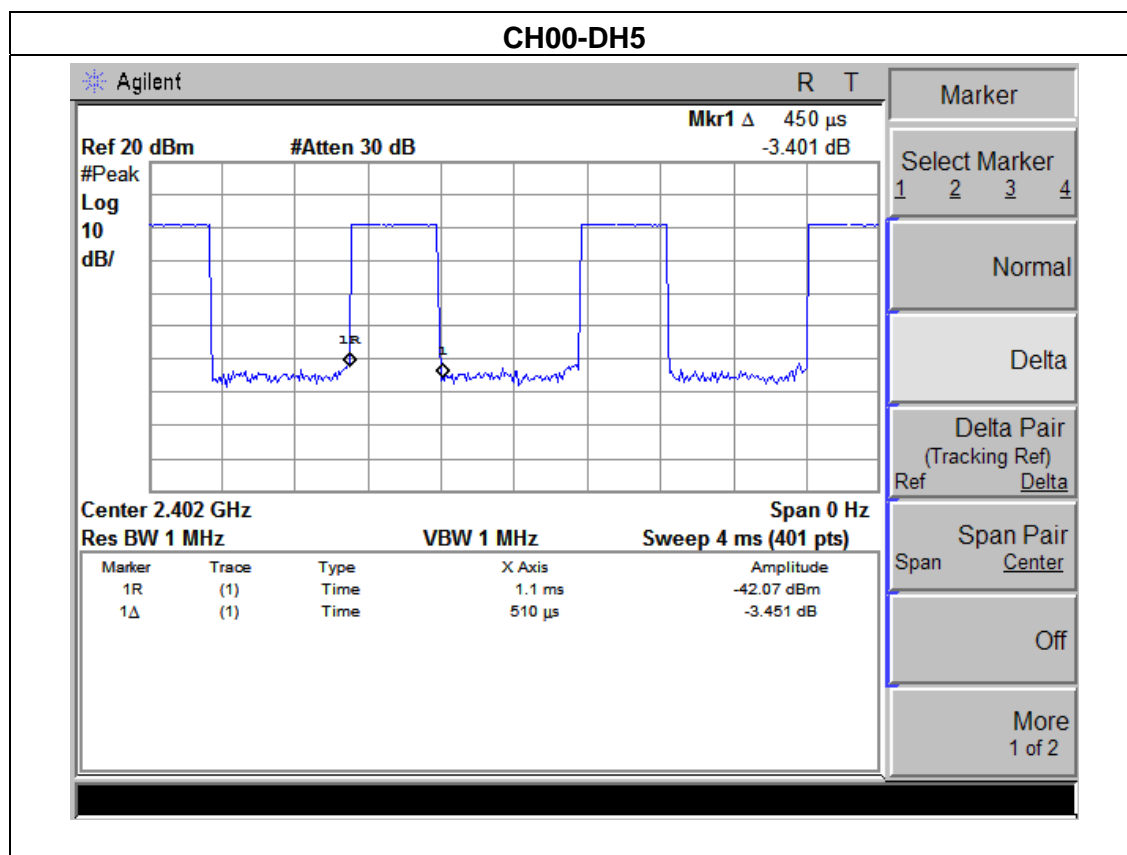

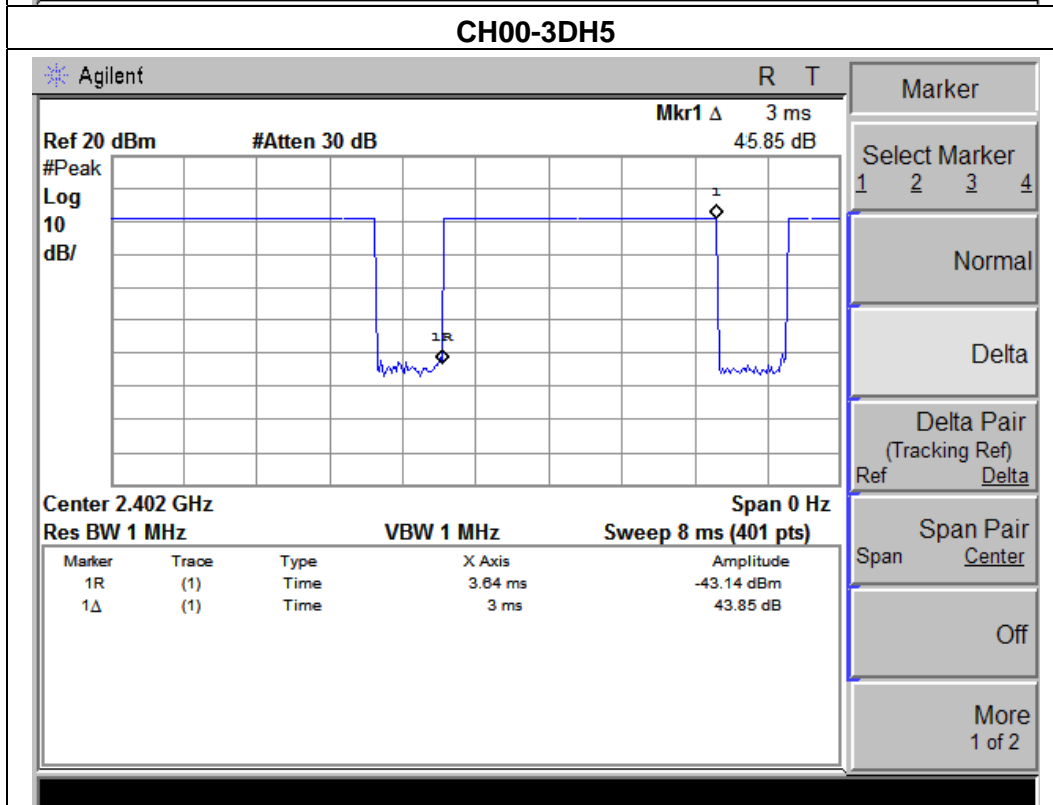
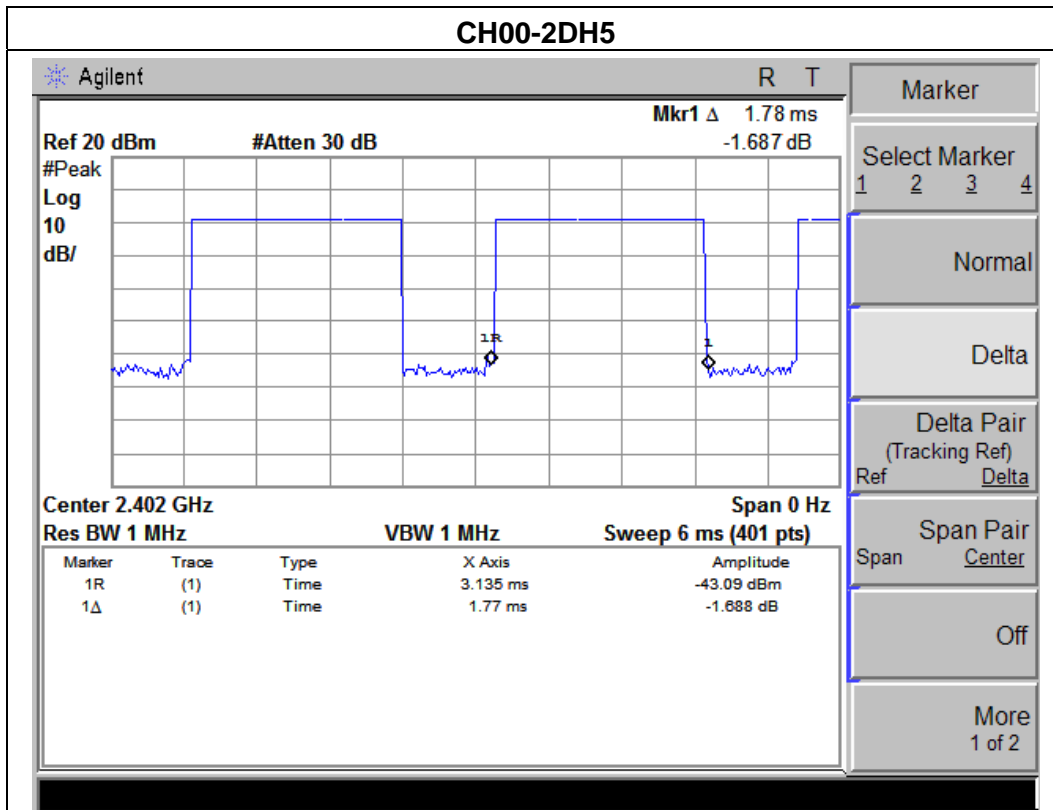

NOTE : The dwell time is showed the maximum data of all data(DH1,2DH1,3DH1, DH3,2DH3,3DH3, DH5,2DH5,3DH5), (DH5,2DH5,3DH5) of mode have the maximum dwell time.

6. HOPPING CHANNEL SEPARATION MEASUREMENT

6.1 APPLIED PROCEDURES / LIMIT

Frequency hopping systems operating in the 2400-2483.5 MHz band may have hopping channel carrier frequencies that are separated by 25 kHz or two-thirds of the 20 dB bandwidth of the hopping channel, whichever is greater.

Spectrum Parameter	Setting
Attenuation	Auto
Span Frequency	> Measurement Bandwidth or Channel Separation
RB	100 kHz (Channel Separation)
VB	100 kHz (Channel Separation)
Detector	Peak
Trace	Max Hold
Sweep Time	Auto

6.1.1 TEST PROCEDURE

- a. The transmitter output (antenna port) was connected to the spectrum analyser in peak hold mode.
- b. The resolution bandwidth of 100 kHz and the video bandwidth of 100 kHz were utilised for channel separation measurement.

6.1.2 DEVIATION FROM STANDARD

No deviation.

6.1.3 TEST SETUP

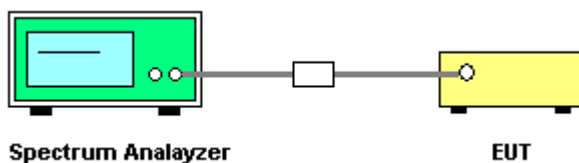

6.1.4 EUT OPERATION CONDITIONS

The EUT was programmed to be in continuously transmitting mode.



6.1.5 TEST RESULTS

EUT :	7.9 inch tablet	Model Name :	EGQ178
Temperature :	26 °C	Relative Humidity :	54%
Pressure :	1012 hPa	Test Voltage :	DC 3.7V
Test Mode :	CH00 / CH39 /CH78 (1Mbps Mode)		

Frequency	Ch. Separation (MHz)	Result
2402 MHz	1.000	Complies
2441 MHz	1.000	Complies
2480 MHz	1.000	Complies

Ch. Separation Limits: >20dB bandwidth or >2/3 of 20dB bandwidth

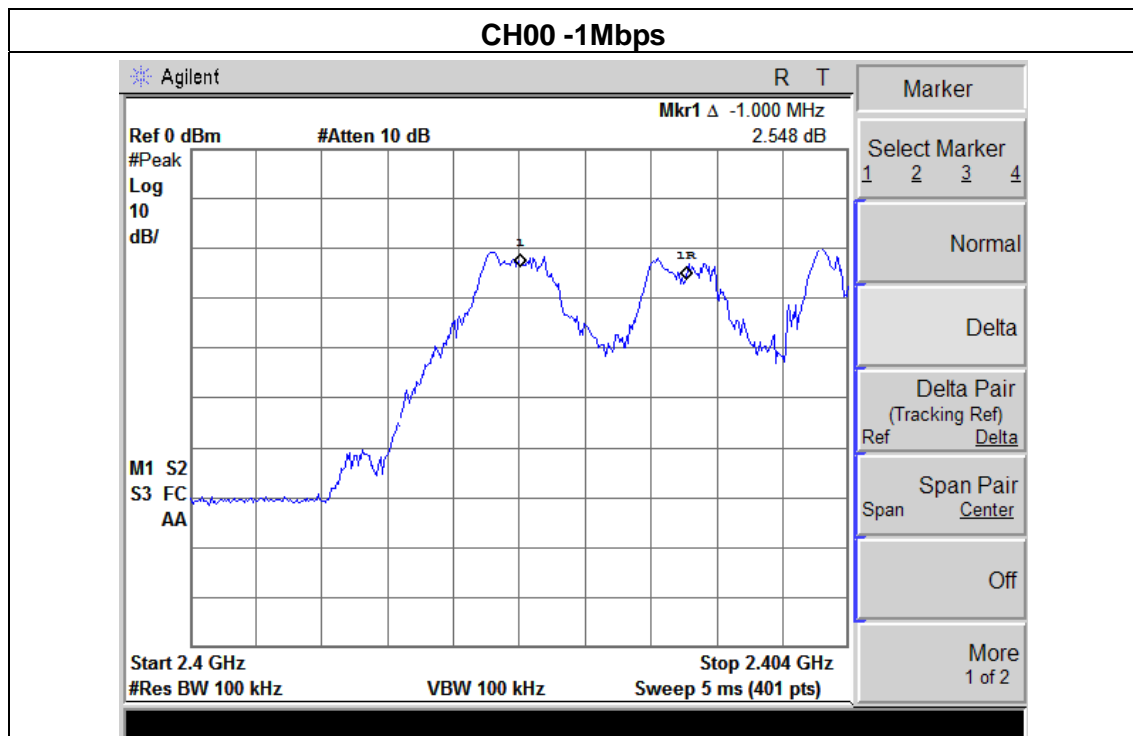

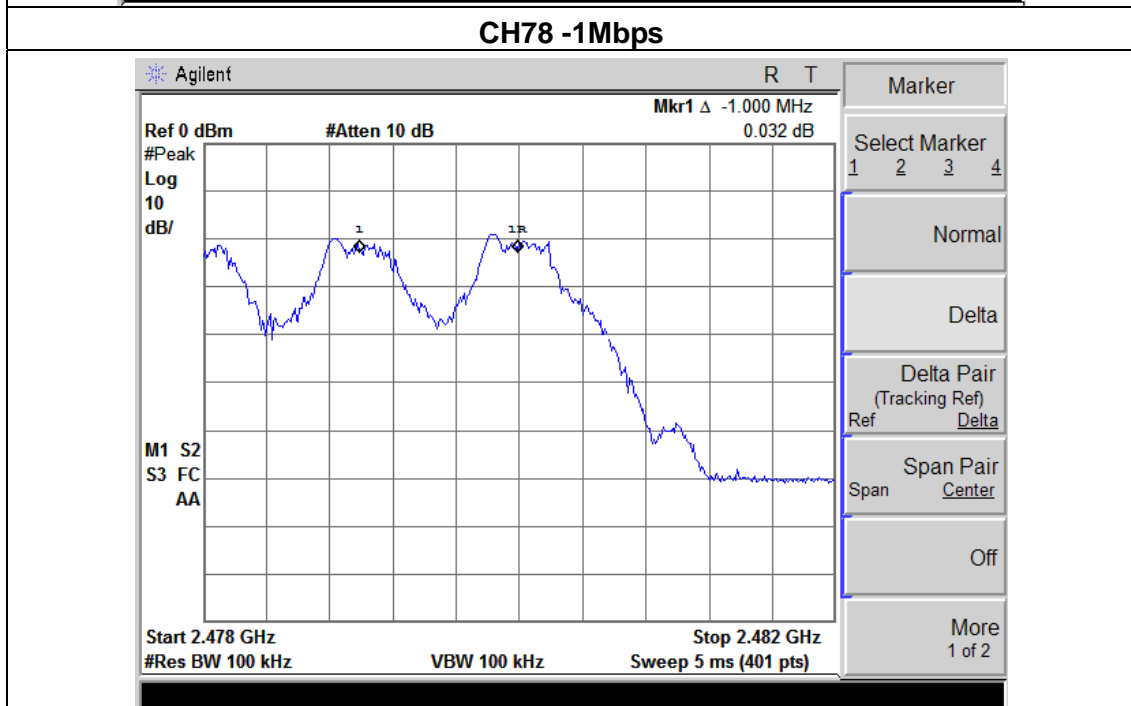
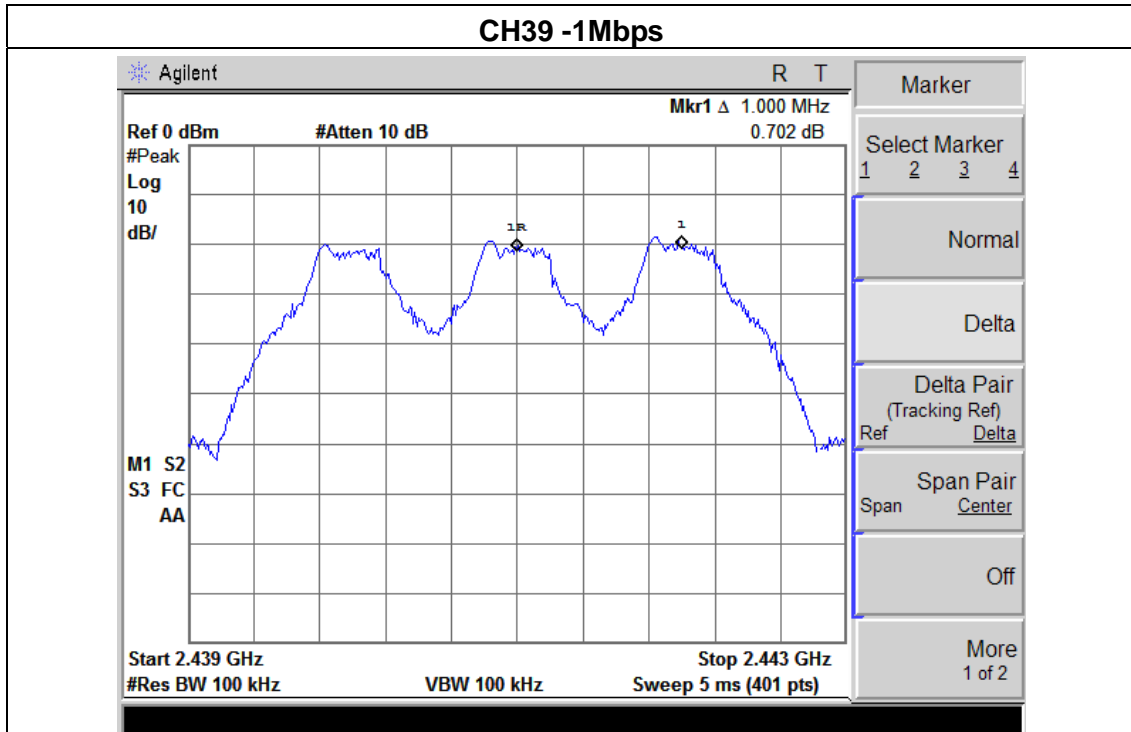



EUT :	7.9 inch tablet	Model Name :	EGQ178
Temperature :	26 °C	Relative Humidity :	54%
Pressure :	1012 hPa	Test Voltage :	DC 3.7V
Test Mode :	CH00 / CH39 /CH78 (2Mbps Mode)		

Frequency	Ch. Separation (MHz)	Result
2402 MHz	1.010	Complies
2441 MHz	1.010	Complies
2480 MHz	1.010	Complies

Ch. Separation Limits: >20dB bandwidth or >2/3 of 20dB bandwidth

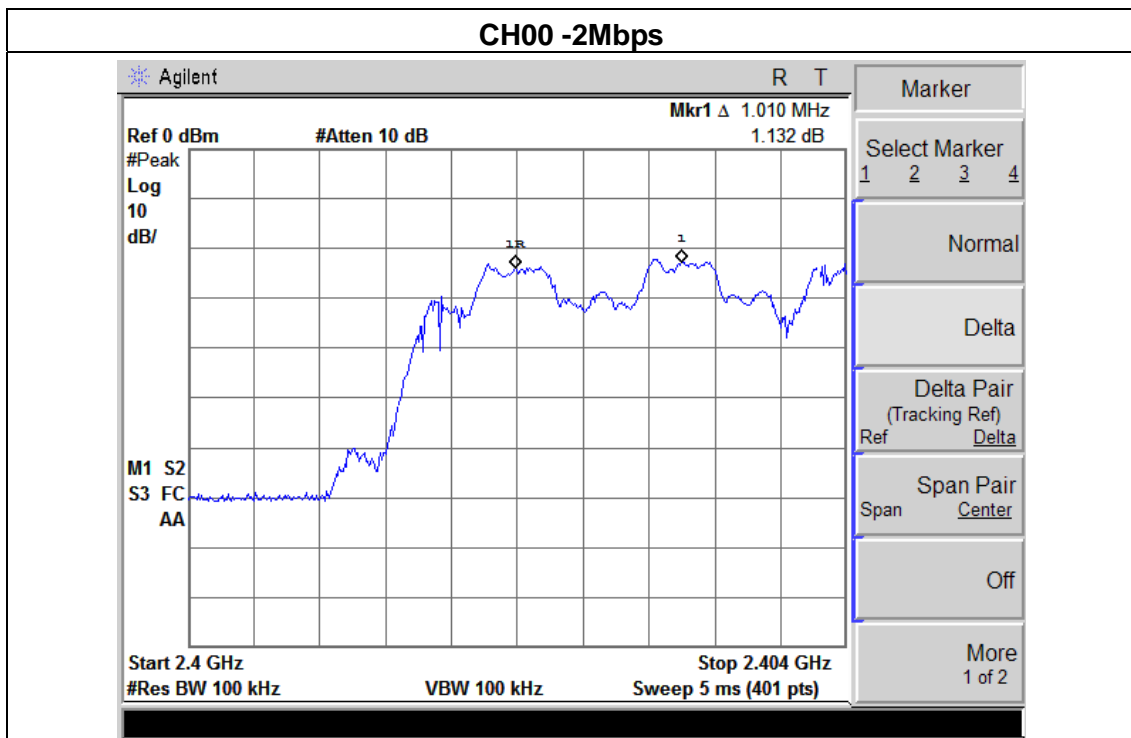

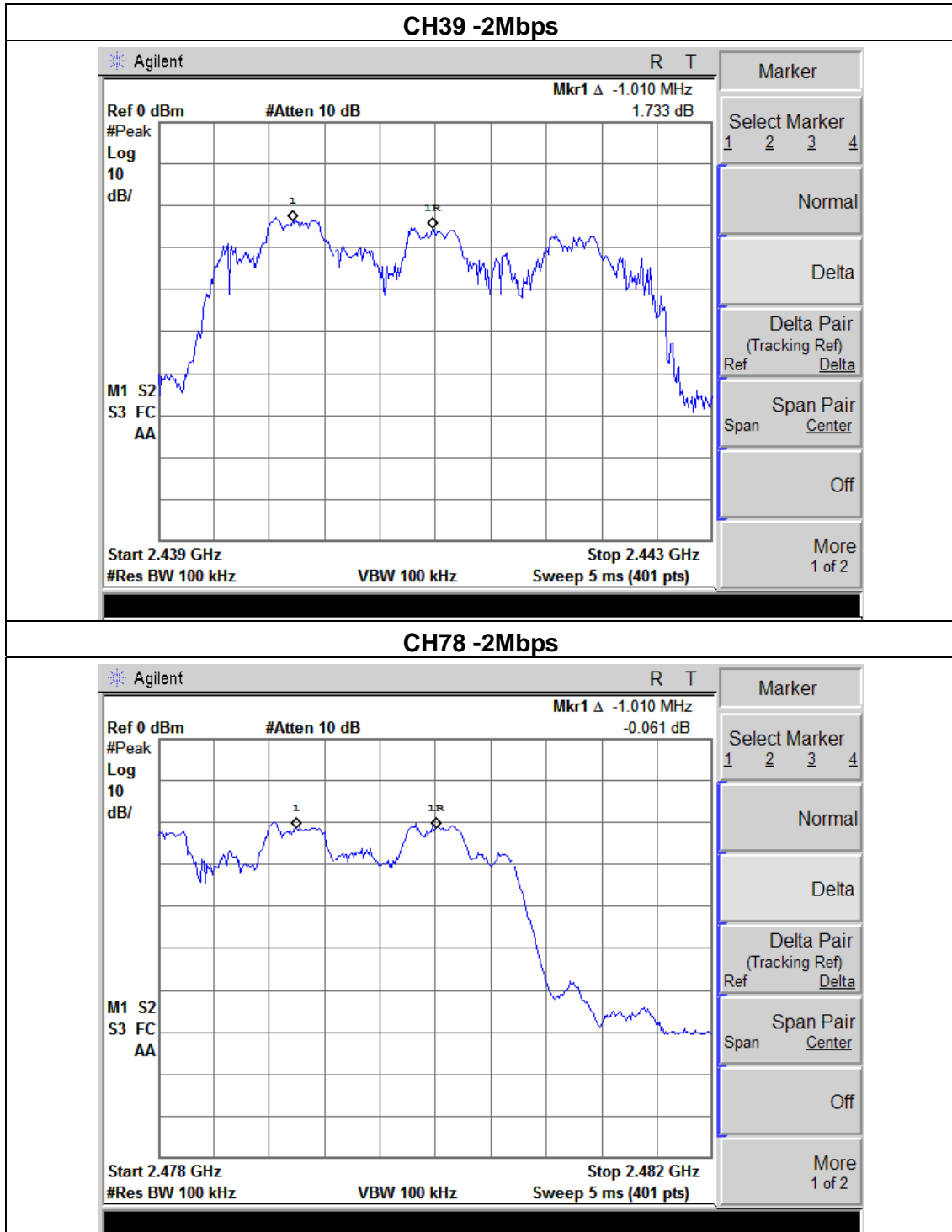

Agilent
R T

Ref 0 dBm
#Atten 10 dB
Mkr1 Δ -1.010 MHz

#Peak

-0.061 dB

Log

10

dB/

M1 S2

S3 FC

AA

Start 2.478 GHz
VBW 100 kHz
Stop 2.482 GHz

#Res BW 100 kHz

Sweep 5 ms (401 pts)

Marker	
Select Marker	1 2 3 4
Normal	
Delta	
Delta Pair (Tracking Ref)	Ref Delta
Span Pair	Span Center
Off	
More	1 of 2



EUT :	7.9 inch tablet	Model Name :	EGQ178
Temperature :	26 °C	Relative Humidity :	54%
Pressure :	1012 hPa	Test Voltage :	DC 3.7V
Test Mode :	CH00 / CH39 /CH78 (3Mbps Mode)		

Frequency	Ch. Separation (MHz)	Result
2402 MHz	1.030	Complies
2441 MHz	1.010	Complies
2480 MHz	1.020	Complies

Ch. Separation Limits: >20dB bandwidth or >2/3 of 20dB bandwidth

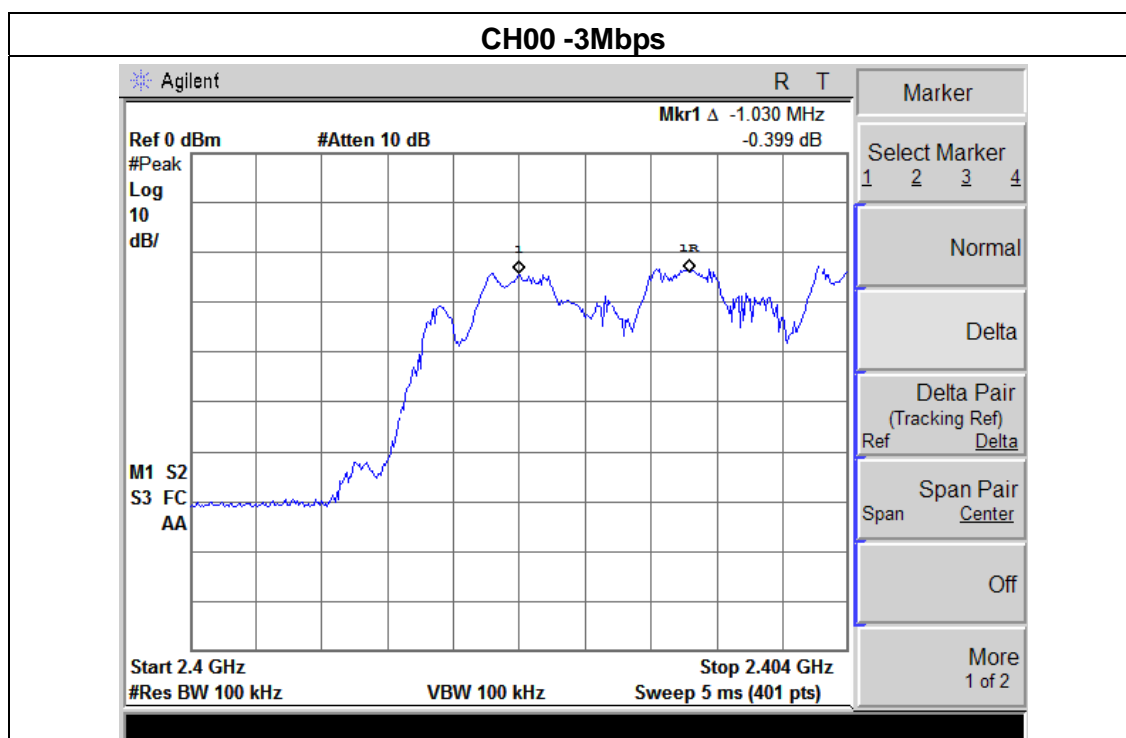

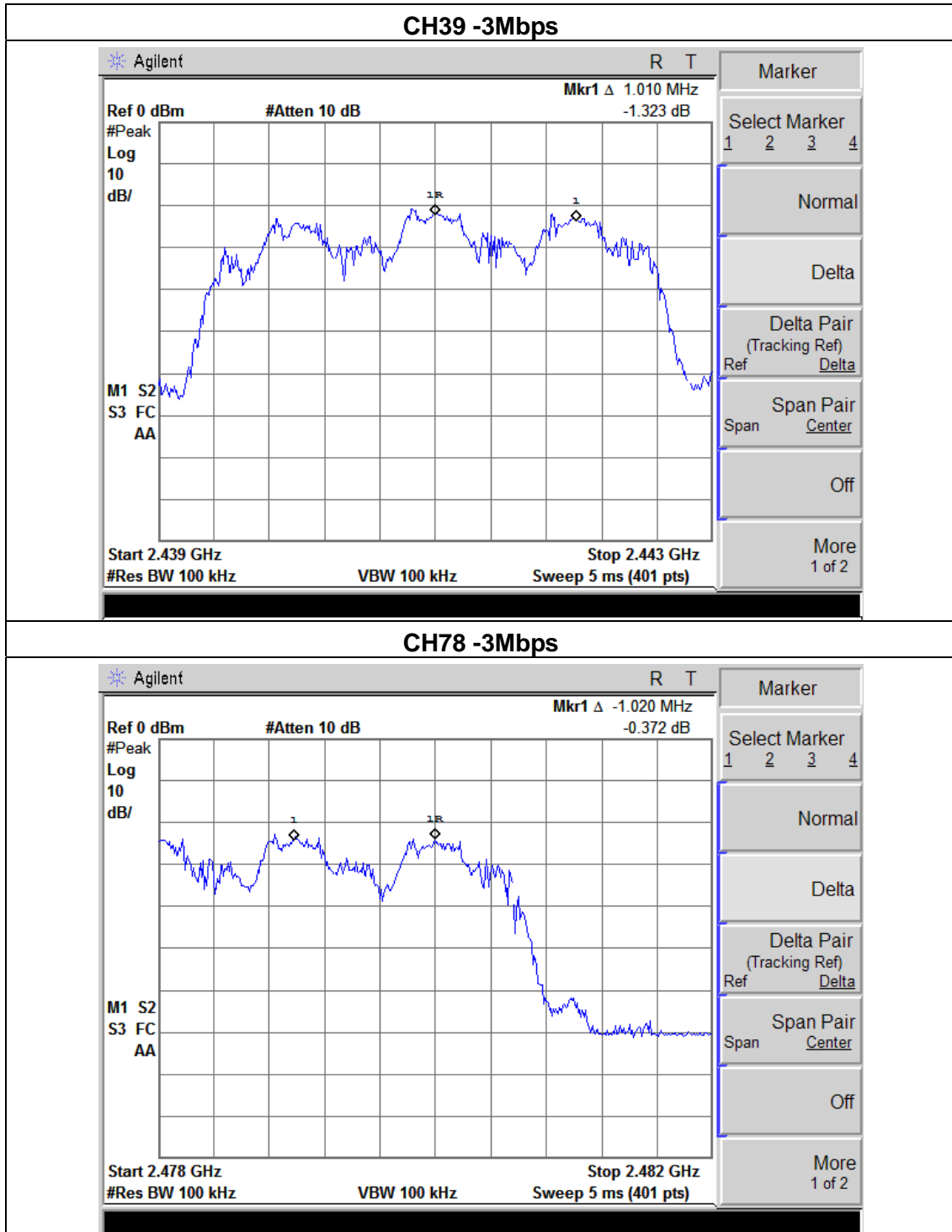



7. BANDWIDTH TEST

7.1 APPLIED PROCEDURES / LIMIT

FCC Part15 (15.247) , Subpart C				
Section	Test Item	Limit	Frequency Range (MHz)	Result
15.247 (a)(1)	Bandwidth	(20dB bandwidth)	2400-2483.5	PASS

Spectrum Parameter	Setting
Attenuation	Auto
Span Frequency	> Measurement Bandwidth or Channel Separation
RB	30 kHz
VB	100 kHz
Detector	Peak
Trace	Max Hold
Sweep Time	Auto

7.1.1 TEST PROCEDURE

- The EUT was directly connected to the spectrum analyzer and antenna output port as show in the block diagram below,
- Spectrum Setting : RBW= 30KHz, VBW=100KHz, Sweep time = Auto.

7.1.2 DEVIATION FROM STANDARD

No deviation.

7.1.3 TEST SETUP

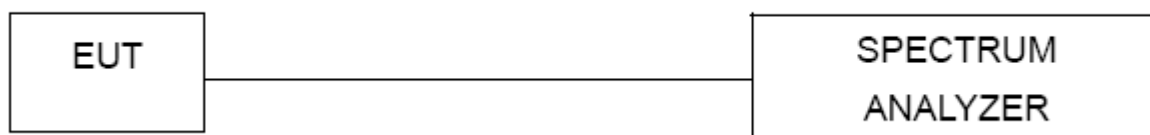

7.1.4 EUT OPERATION CONDITIONS

The EUT tested system was configured as the statements of 2.4 Unless otherwise a special operating condition is specified in the follows during the testing.



7.1.5 TEST RESULTS

EUT :	7.9 inch tablet	Model Name :	EGQ178
Temperature :	26 °C	Relative Humidity :	54%
Pressure :	1012 hPa	Test Voltage :	DC 3.7V
Test Mode :	CH00 / CH39 /C78(1Mbps)		

Frequency	20dB Bandwidth (kHz)	Result
2402 MHz	812.82	PASS
2441 MHz	821.04	PASS
2480 MHz	826.15	PASS

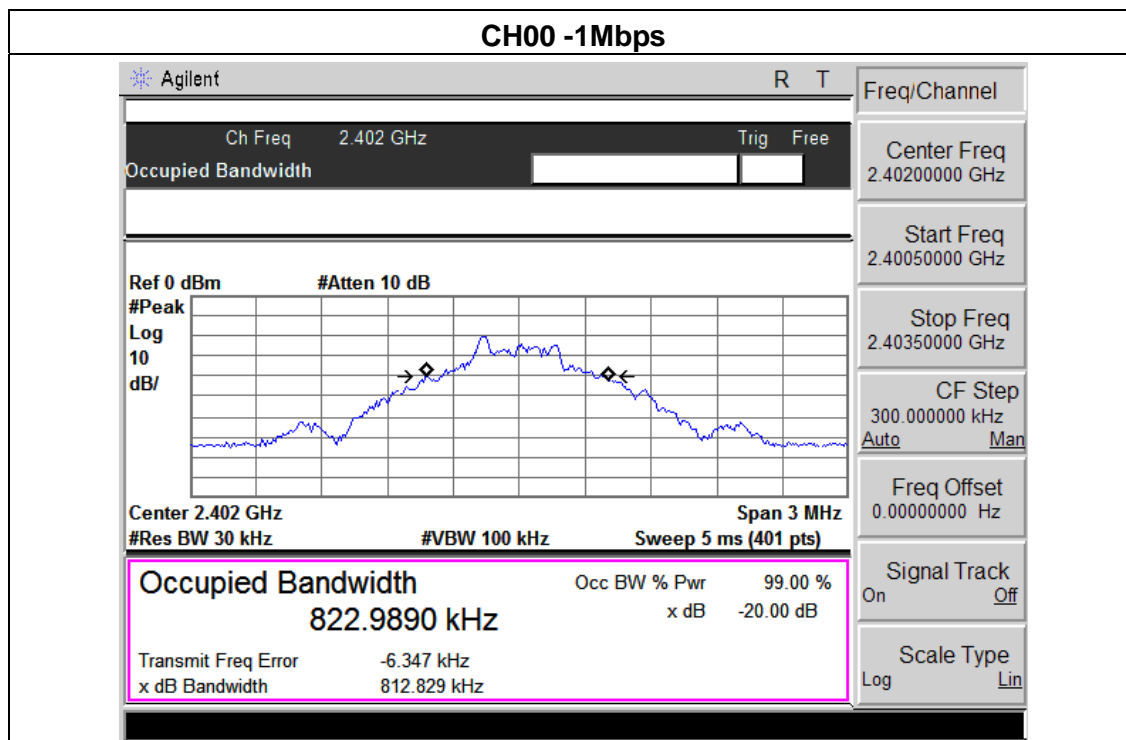

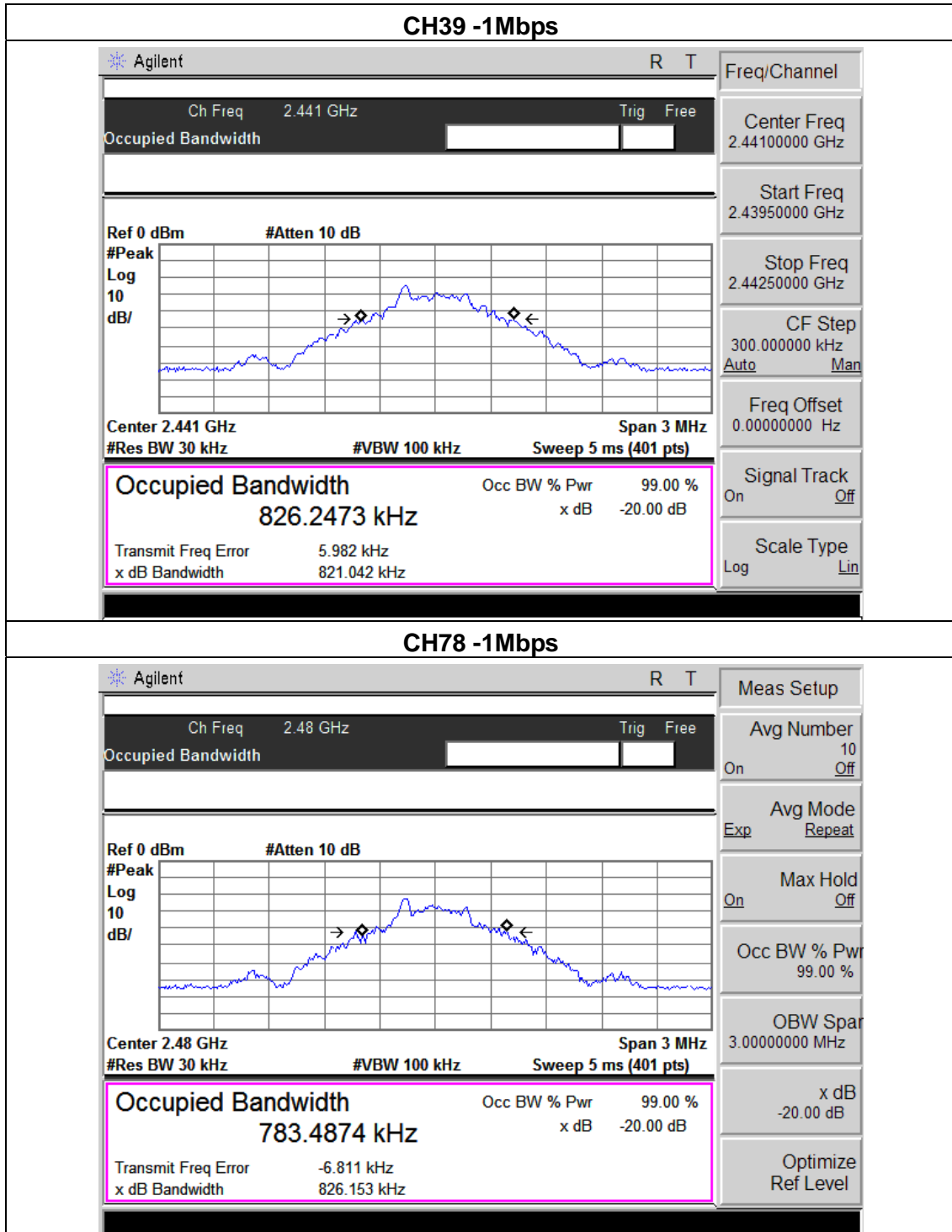



EUT :	7.9 inch tablet	Model Name :	EGQ178
Temperature :	26 °C	Relative Humidity :	54%
Pressure :	1012 hPa	Test Voltage :	DC 3.7V
Test Mode :	CH00 / CH39 /C78(2Mbps)		

Frequency	20dB Bandwidth (MHz)	Result
2402 MHz	1.118	PASS
2441 MHz	1.113	PASS
2480 MHz	1.067	PASS

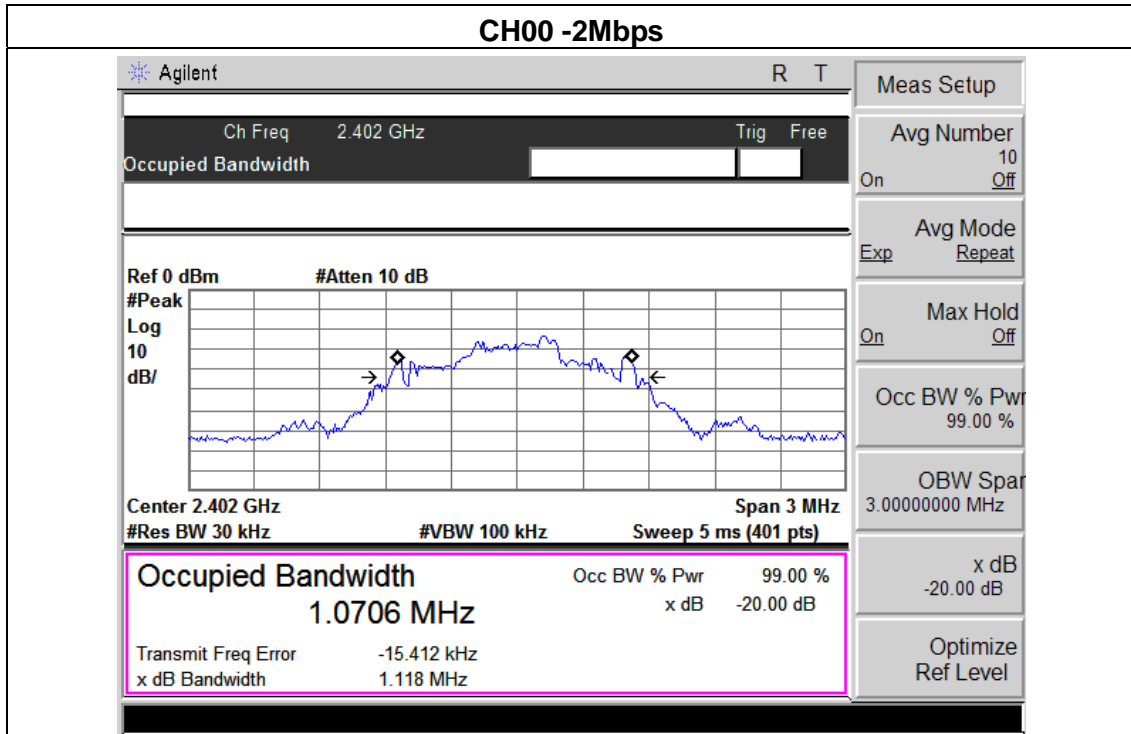

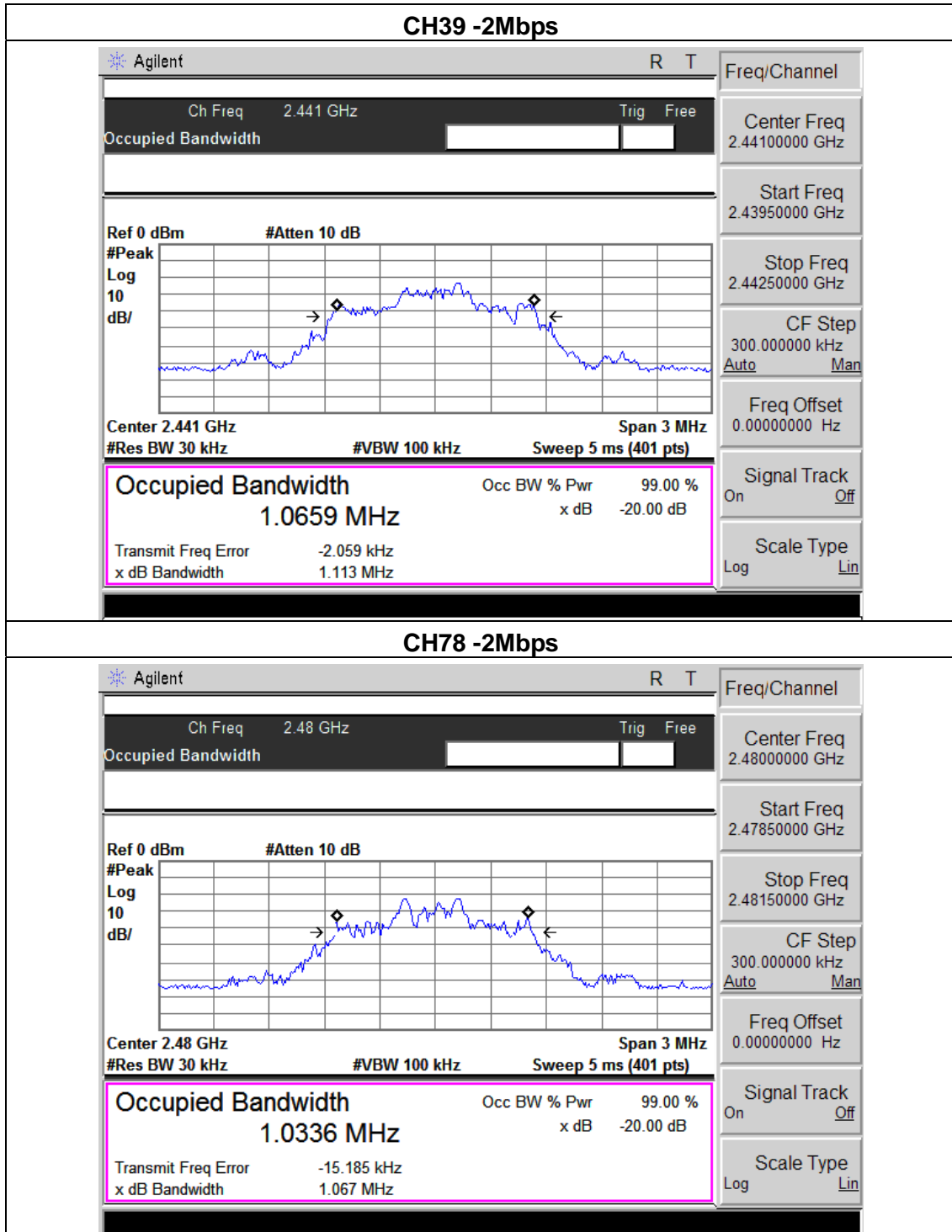



EUT :	7.9 inch tablet	Model Name :	EGQ178
Temperature :	26 °C	Relative Humidity :	54%
Pressure :	1012 hPa	Test Voltage :	DC 3.7V
Test Mode :	CH00 / CH39 /C78(3Mbps)		

Frequency	20dB Bandwidth (MHz)	Result
2402 MHz	1.136	PASS
2441 MHz	1.127	PASS
2480 MHz	1.134	PASS

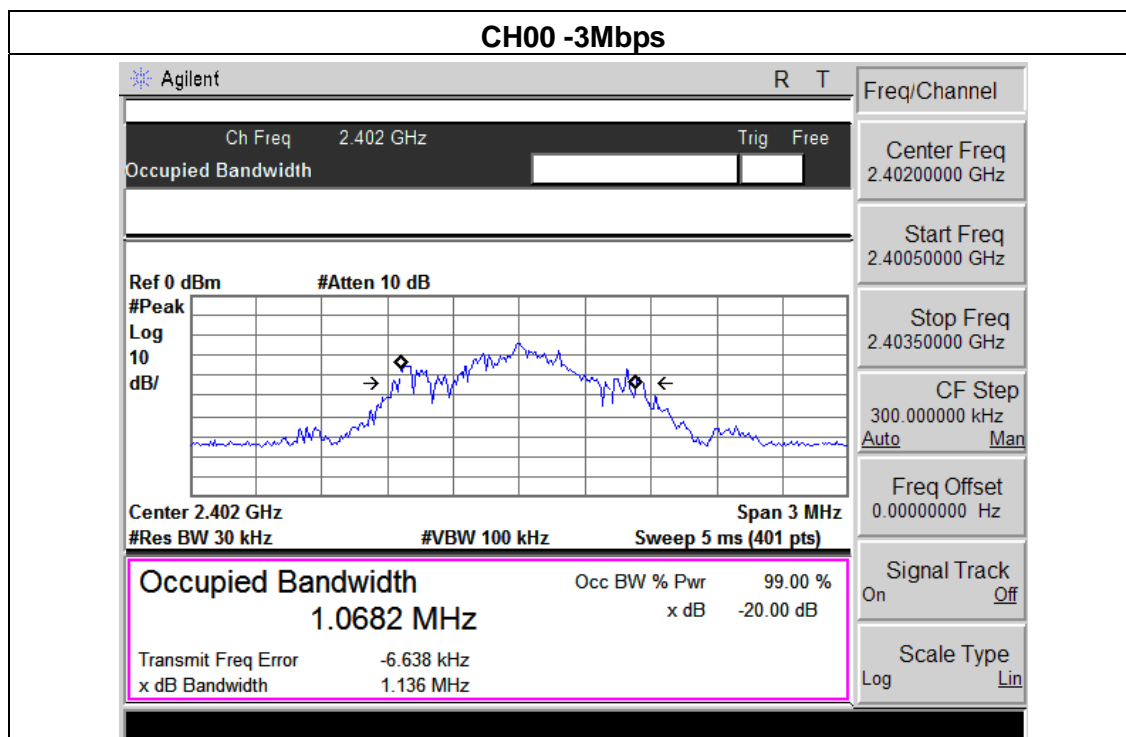





8. PEAK OUTPUT POWER TEST

8.1 APPLIED PROCEDURES / LIMIT

FCC Part15 (15.247) , Subpart C				
Section	Test Item	Limit	Frequency Range (MHz)	Result
15.247 (b)(i)	Peak Output Power	0.125 w or 20.96dBm	2400-2483.5	PASS

8.1.1 TEST PROCEDURE

- a. The EUT was directly connected to the spectrum analyzer and antenna output port as show in the block diagram below,
- b. Spectrum Setting : RBW > the 20 dB bandwidth of the emission being measured
Span = approximately 5 times the 20 dB bandwidth, centered on a hopping channel
VBW \geq RBW
Sweep = auto
Detector function = peak
Trace = max hold

8.1.2 DEVIATION FROM STANDARD

No deviation.

8.1.3 TEST SETUP



8.1.4 EUT OPERATION CONDITIONS

The EUT tested system was configured as the statements of 2.4 Unless otherwise a special operating condition is specified in the follows during the testing.



8.1.5 TEST RESULTS

EUT :	7.9 inch tablet	Model Name :	EGQ178
Temperature :	26 °C	Relative Humidity :	54%
Pressure :	1012 hPa	Test Voltage :	DC 3.7V
Test Mode :	CH00/ CH39 /CH78 (1M/2M/3Mbps Mode)		

1Mbps			
Test Channel	Frequency (MHz)	Peak Output Power (dBm)	LIMIT (dBm)
CH00	2402	1.030	30
CH39	2441	1.462	30
CH78	2480	1.229	30
2Mbps			
CH00	2402	0.579	20.96
CH39	2441	0.685	20.96
CH78	2480	-0.292	20.96
3Mbps			
CH00	2402	-0.929	20.96
CH39	2441	-0.810	20.96
CH78	2480	-0.736	20.96

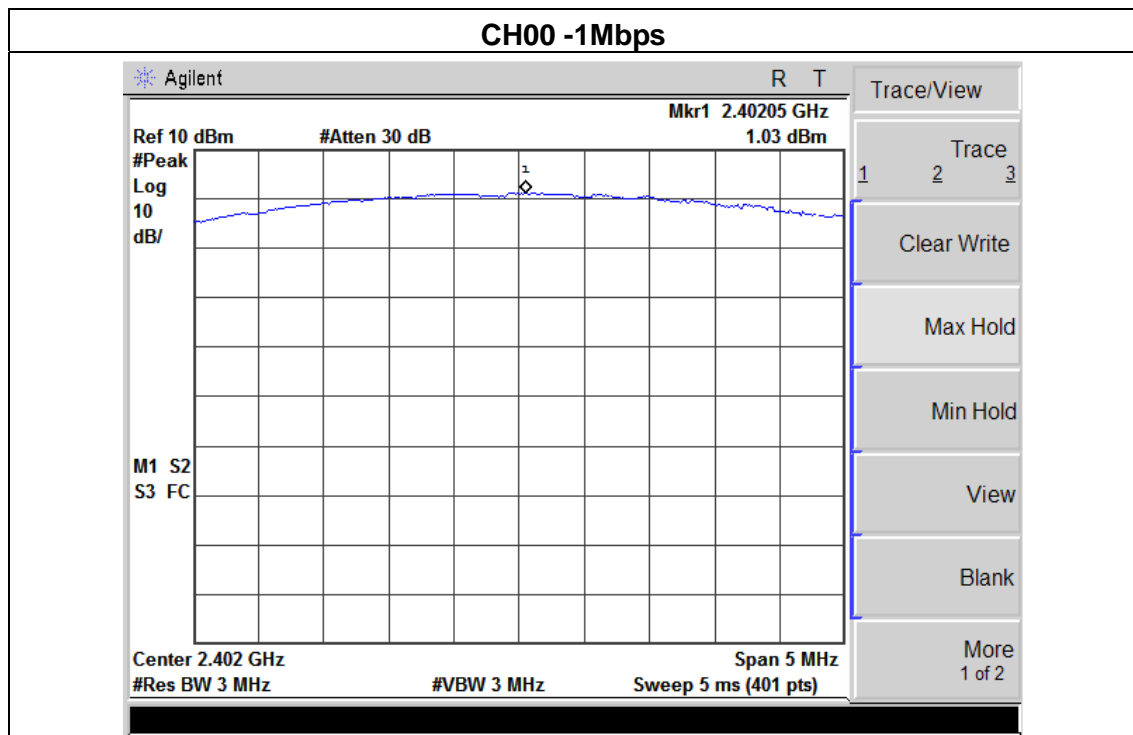

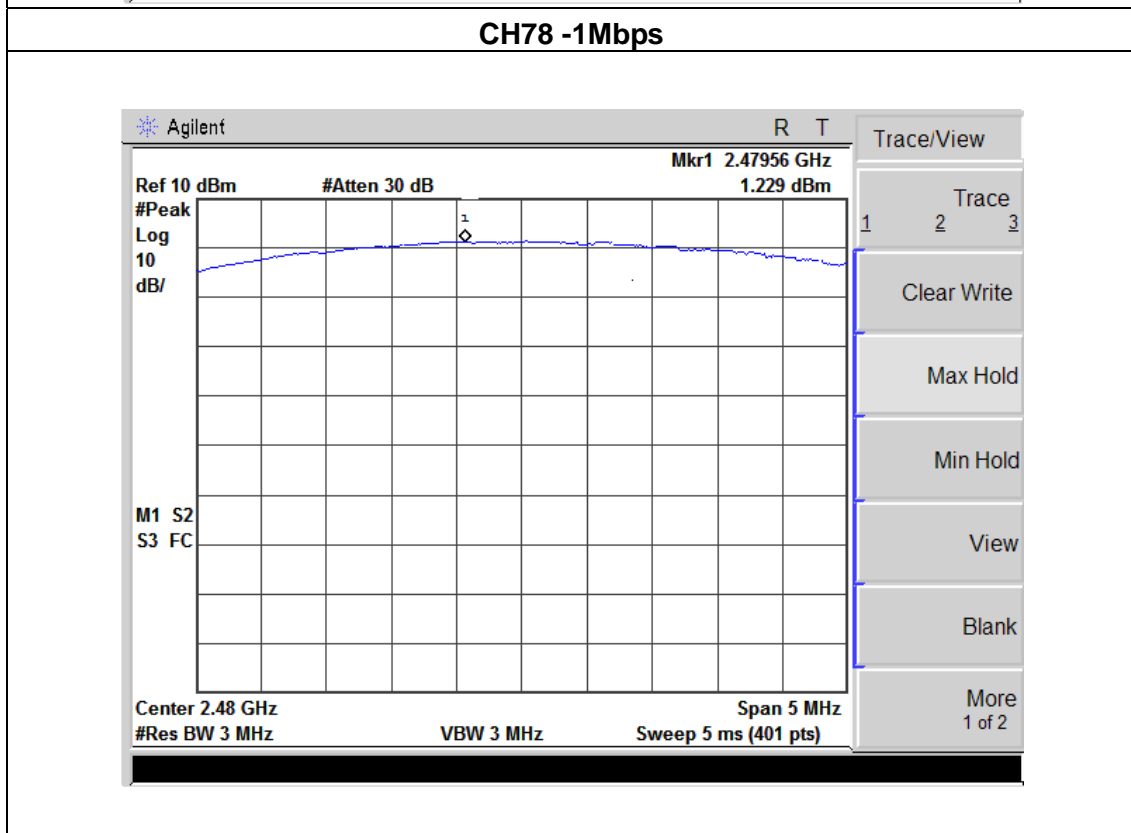
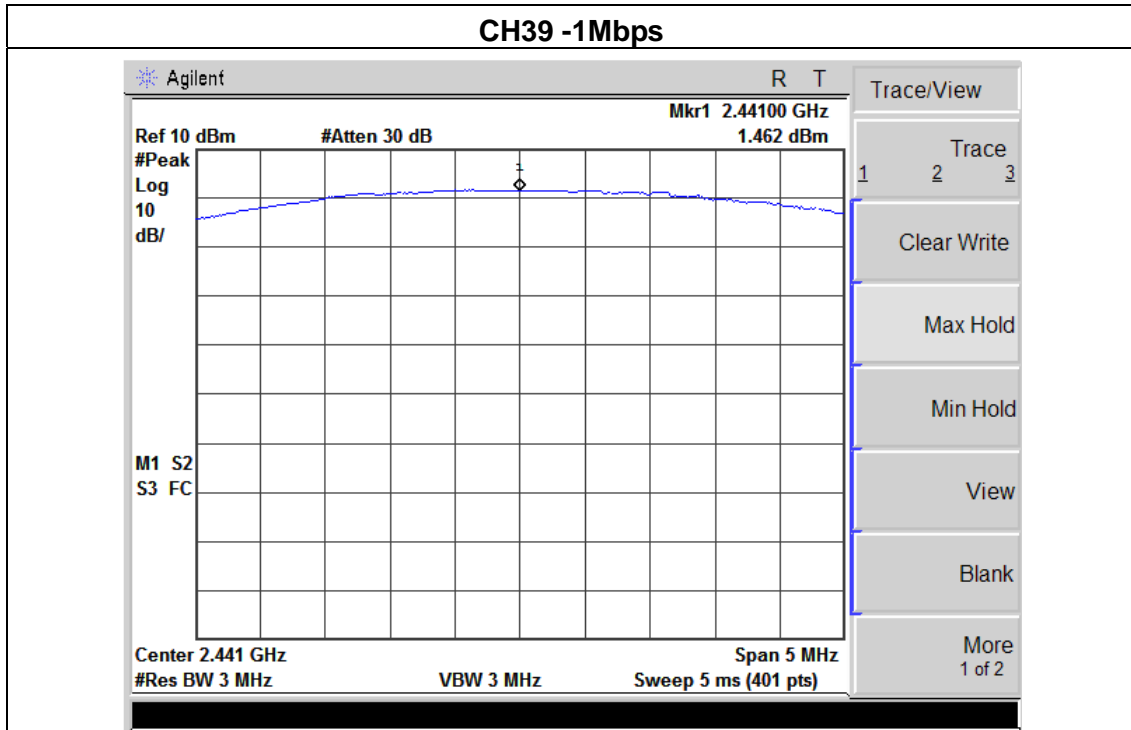

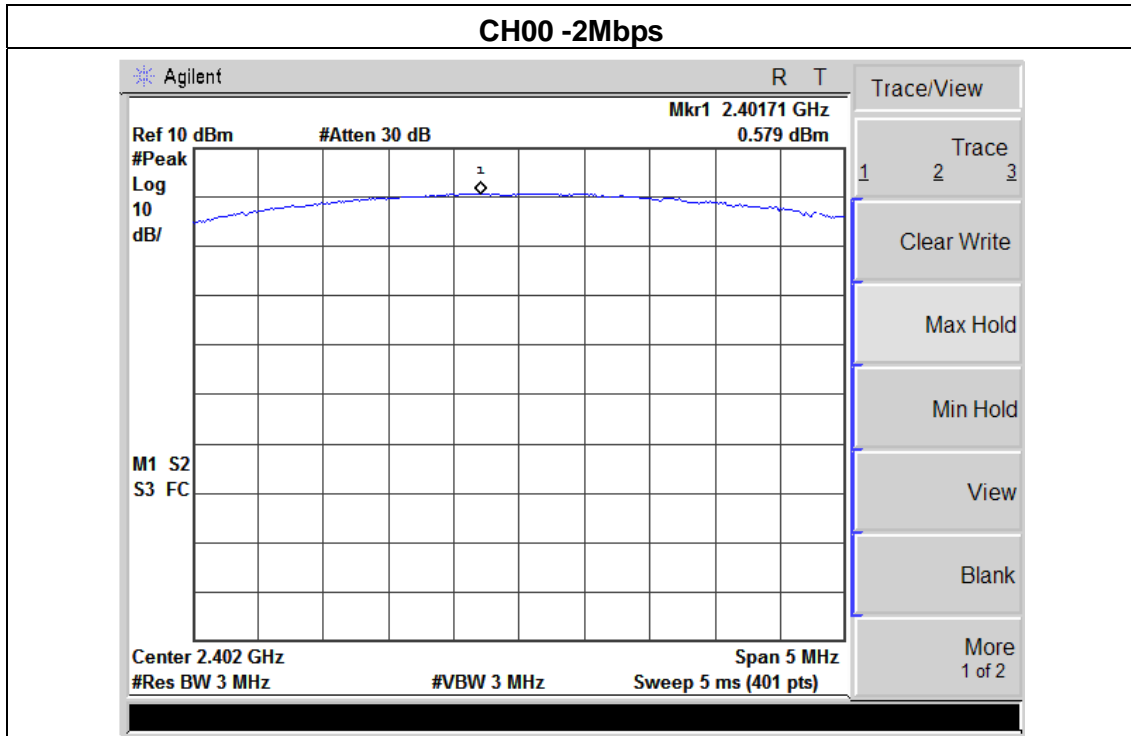

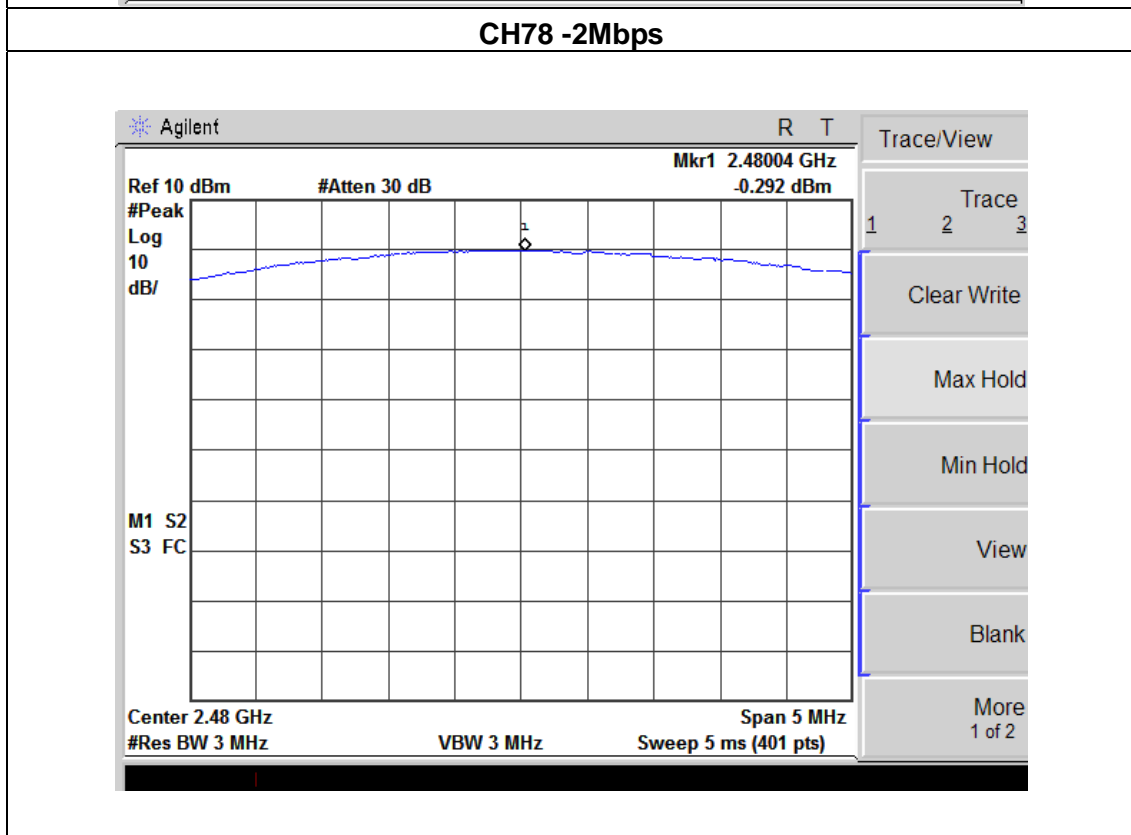
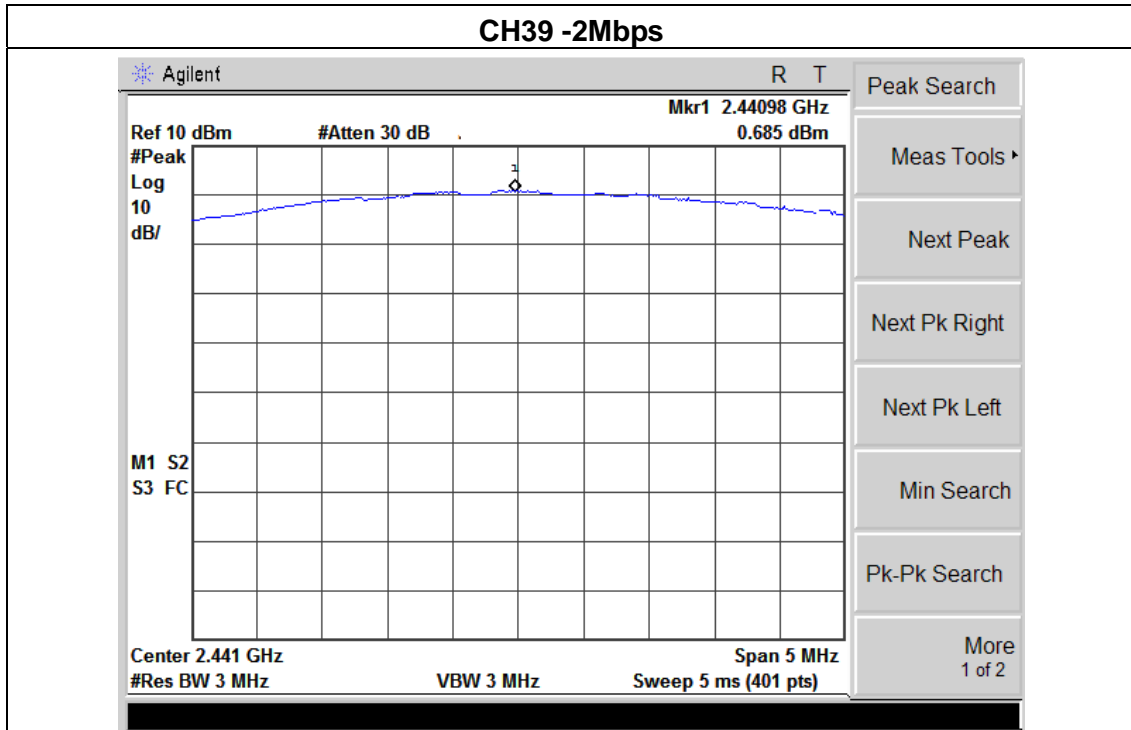

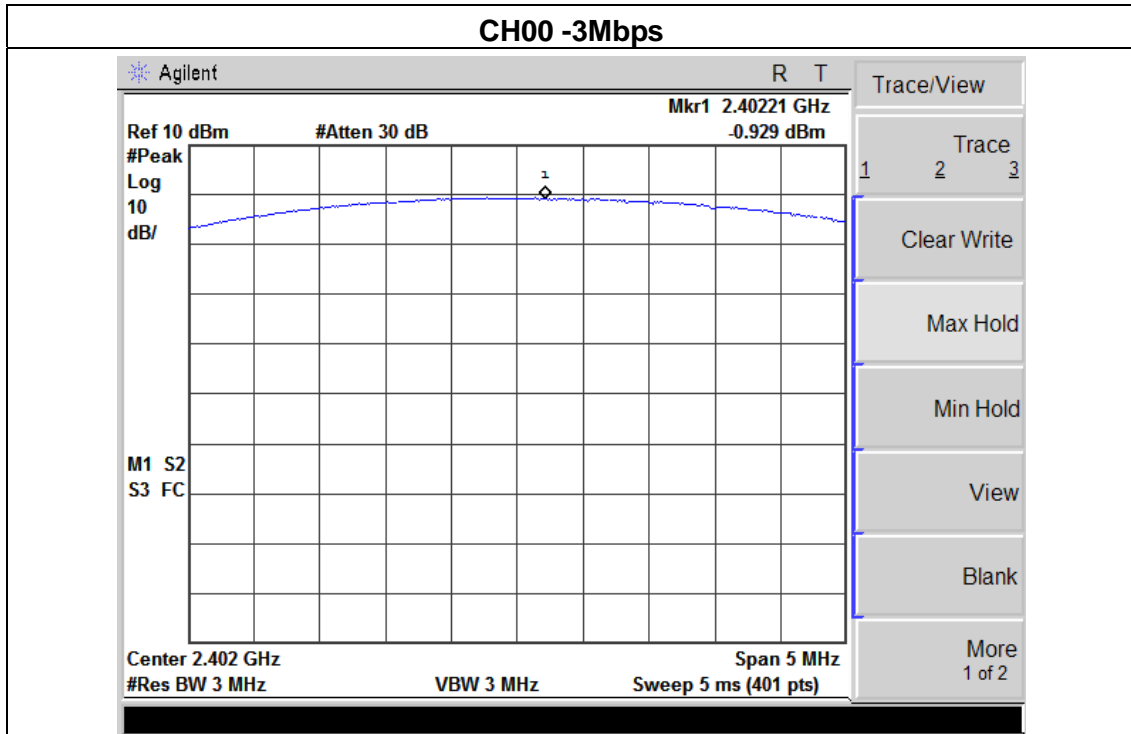

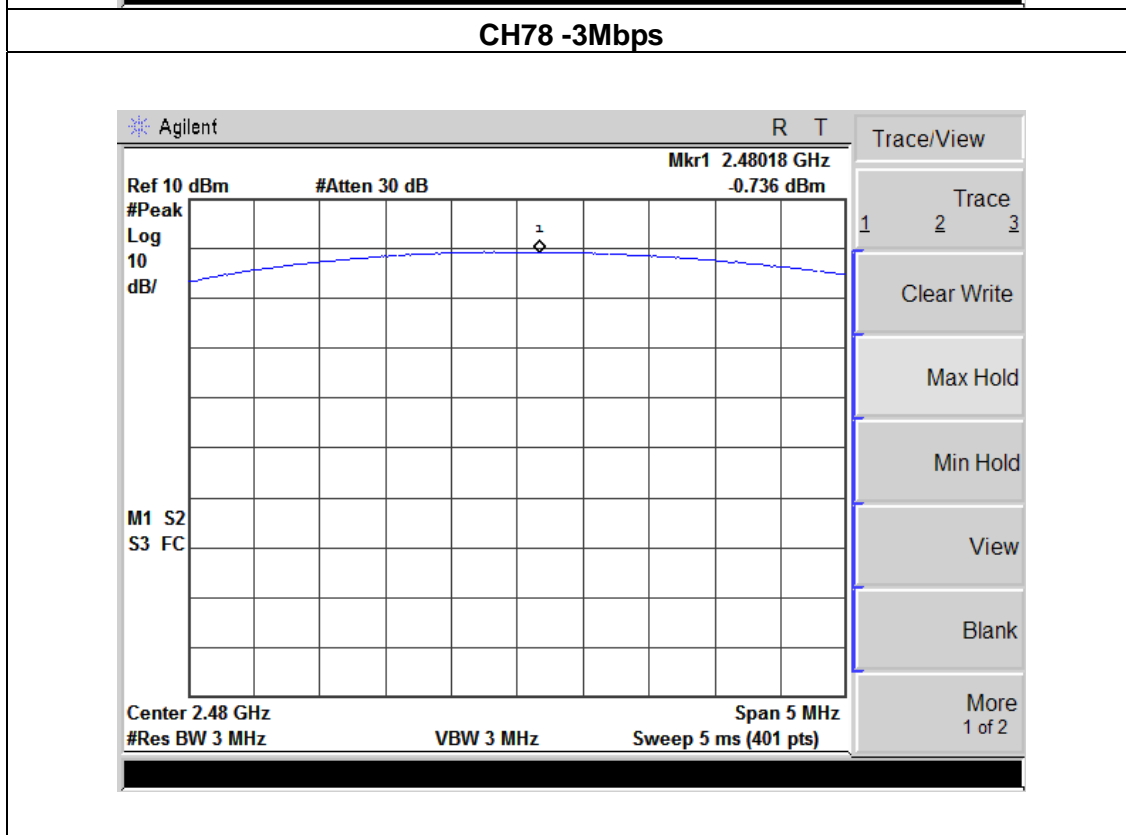
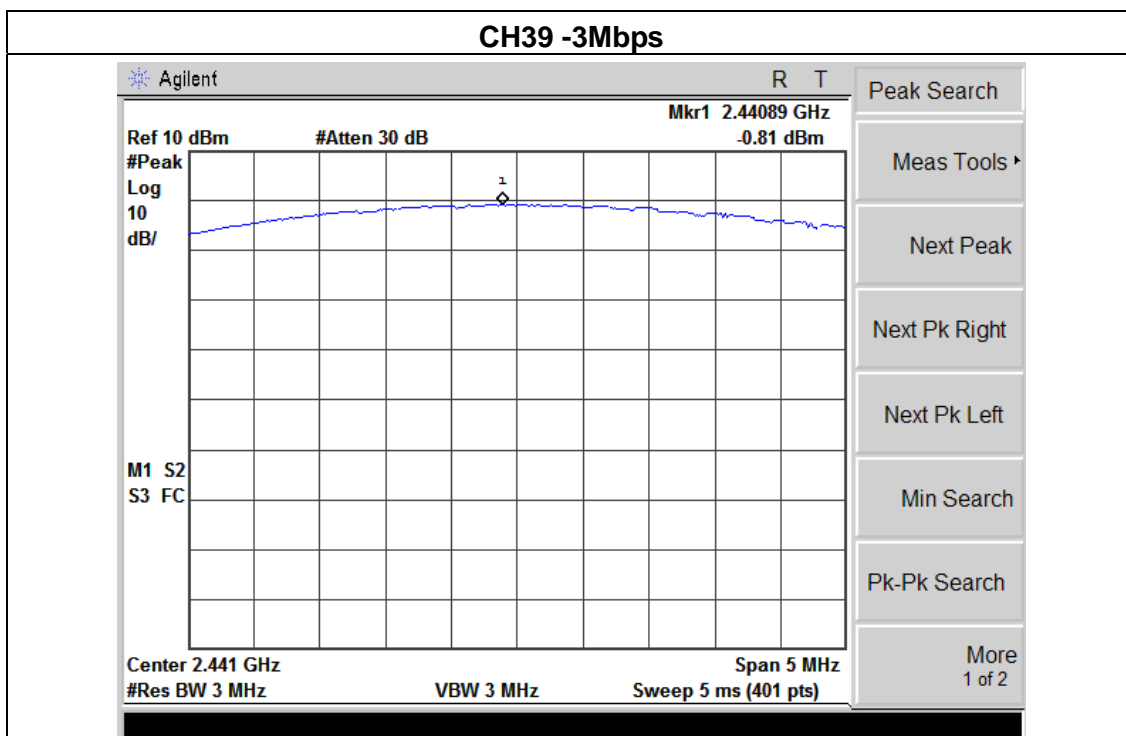



9. ANTENNA REQUIREMENT

9.1 STANDARD REQUIREMENT

For intentional device, according to FCC 47 CFR Section 15.203, an intentional radiator shall be designed to ensure that no antenna other than that furnished by the responsible party shall be used with the device. And according to FCC 47 CFR Section 15.247 (b), if transmitting antennas of directional gain greater than 6dBi are used, the power shall be reduced by the amount in dB that the directional gain of the antenna exceeds 6dBi.

9.2 EUT ANTENNA

The antennas used for this product are Internal Antenna and that no antenna other than that furnished by the responsible party shall be used with the device, the maximum peak gain of the transmit antenna is only 1.0 dBi.



10. EUT TEST PHOTO

Radiated Measurement Photos

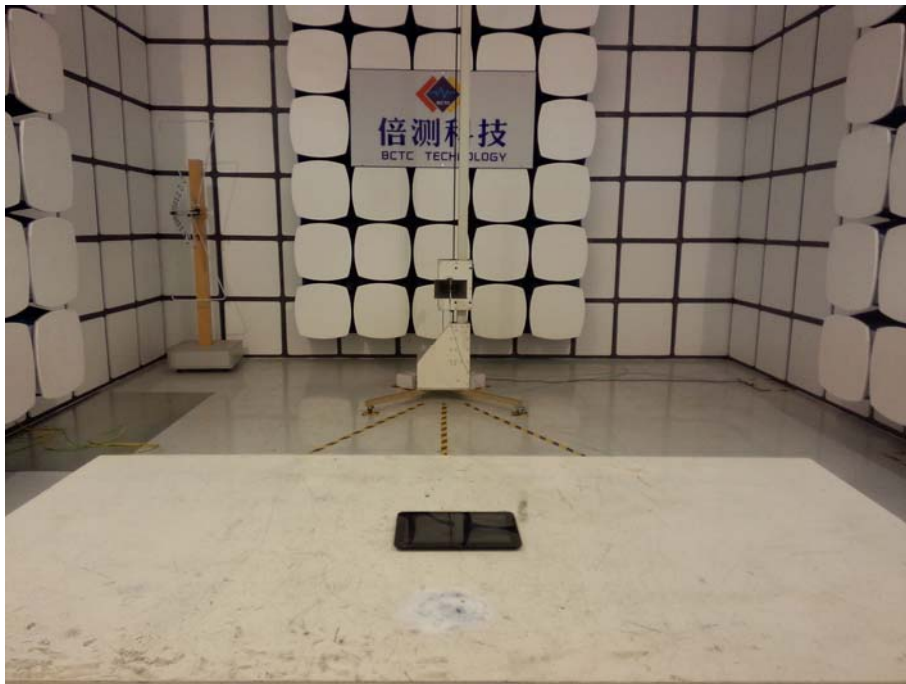
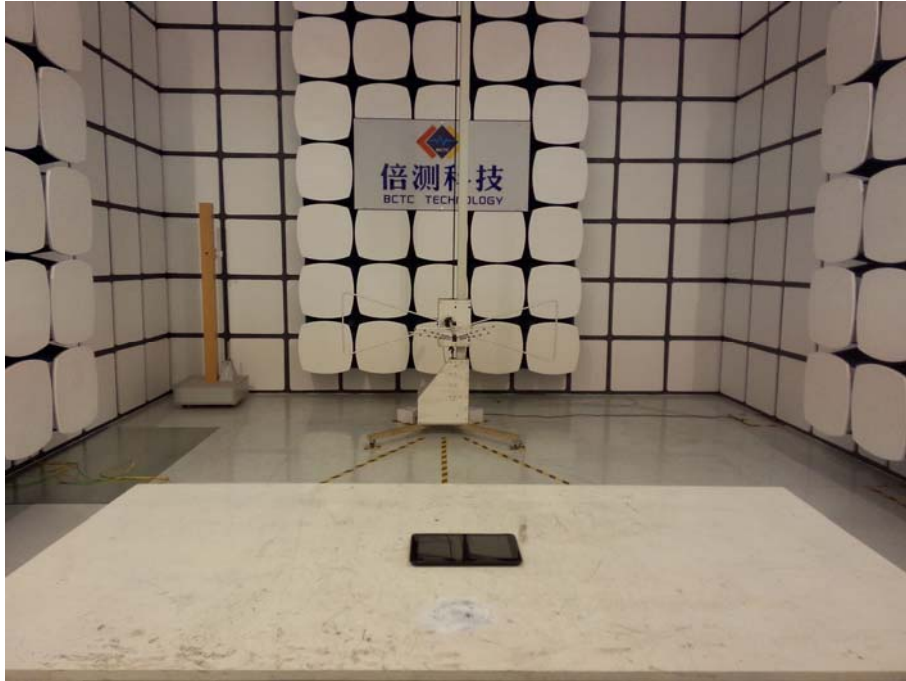



Radiated Measurement Photos

