



# FCC RADIO TEST REPORT

## FCC ID: XHWEGD103

**Product :** Tablet PC

**Trade Name :** The logo for E-matic, consisting of a blue stylized 'e' followed by the word 'ematic' in a sans-serif font.

**Model Name :** EGD103

**Serial Model :** HS-10DTB5-4GB, HS-10DTB5-8GB,  
HS-10DTB5-16GB, HS-10DTB5-32GB

**Report No. :** NTEK- 2013NT1125633F

### Prepared for

E-matic

3435 Ocean Park Blvd #107 PMB # 444, Santa Monica CA 90405, United States

### Prepared by

Shenzhen NTEK Testing Technology Co., Ltd.

1/F, Building E, Fenda Science Park, Sanwei Community, Xixiang Street  
Bao'an District, Shenzhen P.R. China

Tel.: +86-0755-61156588 Fax.: +86-0755-61156599

Website: [www.ntek.org.cn](http://www.ntek.org.cn)

## TEST RESULT CERTIFICATION

**Applicant's name** ..... : E-matic  
**Address** ..... : 3435 Ocean Park Blvd #107 PMB # 444, Santa Monica CA  
90405, United States

**Manufacturer's Name** ..... : SHAGHAL LTD  
**Address** ..... : North door,jiatian Industrial Park,Wulian of Fenggang  
Town,Dongguan,Guangdong, Province,China

### Product description

**Product name** ..... : Tablet PC  
**Model and/or type reference** : EGD103  
**Serial Model** ..... : HS-10DTB5-4GB,HS-10DTB5-8GB,  
HS-10DTB5-16GB,HS-10DTB5-32GB

**Standards** ..... : FCC Part15.247

**Test procedure** ..... ANSI C63.4-2003

This device described above has been tested by NTEK, and the test results show that the equipment under test (EUT) is in compliance with the FCC requirements. And it is applicable only to the tested sample identified in the report.

This report shall not be reproduced except in full, without the written approval of NTEK, this document may be altered or revised by NTEK, personal only, and shall be noted in the revision of the document.

**Date of Test** .....

**Date (s) of performance of tests** ..... : 25 Nov. 2013 ~ 02 Dec. 2013

**Date of Issue**..... : 02 Dec. 2013

**Test Result**..... : **Pass**

Testing Engineer : \_\_\_\_\_

*Saint Xu*

(Saint Xu)

Technical Manager : \_\_\_\_\_

*Brown Lu*

(Brown Lu)

Authorized Signatory : \_\_\_\_\_

*Bovey Yang*

(Bovey Yang)

**Table of Contents**

	<b>Page</b>
<b>1 . SUMMARY OF TEST RESULTS</b>	<b>5</b>
1.1 TEST FACILITY	6
1.2 MEASUREMENT UNCERTAINTY	6
<b>2 . GENERAL INFORMATION</b>	<b>7</b>
2.1 GENERAL DESCRIPTION OF EUT	7
2.2 DESCRIPTION OF TEST MODES	9
2.3 BLOCK DIGRAM SHOWING THE CONFIGURATION OF SYSTEM TESTED	10
2.4 DESCRIPTION OF SUPPORT UNITS(CONDUCTED MODE)	11
2.5 EQUIPMENTS LIST FOR ALL TEST ITEMS	12
<b>3 . EMC EMISSION TEST</b>	<b>13</b>
3.1 CONDUCTED EMISSION MEASUREMENT	13
3.1.1 POWER LINE CONDUCTED EMISSION LIMITS	13
3.1.2 TEST PROCEDURE	14
3.1.3 DEVIATION FROM TEST STANDARD	14
3.1.4 TEST SETUP	14
3.1.5 EUT OPERATING CONDITIONS	14
3.1.6 TEST RESULTS	15
3.2 RADIATED EMISSION MEASUREMENT	17
3.2.1 RADIATED EMISSION LIMITS	17
3.2.2 TEST PROCEDURE	18
3.2.3 DEVIATION FROM TEST STANDARD	18
3.2.4 TEST SETUP	19
3.2.5 EUT OPERATING CONDITIONS	20
3.2.6 TEST RESULTS (BETWEEN 9KHZ – 30 MHZ)	21
3.2.7 TEST RESULTS (BETWEEN 30MHZ – 1GHZ)	22
3.2.8 TEST RESULTS (ABOVE 1000 MHZ)	23
<b>4 . POWER SPECTRAL DENSITY TEST</b>	<b>36</b>
4.1 APPLIED PROCEDURES / LIMIT	36
4.1.1 TEST PROCEDURE	36
4.1.2 DEVIATION FROM STANDARD	36
4.1.3 TEST SETUP	36
4.1.4 EUT OPERATION CONDITIONS	36
4.1.5 TEST RESULTS	37
<b>5 . BANDWIDTH TEST</b>	<b>45</b>
5.1 APPLIED PROCEDURES / LIMIT	45
5.1.1 TEST PROCEDURE	45

**Table of Contents**

	<b>Page</b>
5.1.2 TEST SETUP	45
5.1.3 EUT OPERATION CONDITIONS	45
5.1.4 TEST RESULTS	46
<b>6 . PEAK OUTPUT POWER TEST</b>	<b>54</b>
6.1 APPLIED PROCEDURES / LIMIT	54
6.1.1 TEST PROCEDURE	54
6.1.2 DEVIATION FROM STANDARD	54
6.1.3 TEST SETUP	54
6.1.4 EUT OPERATION CONDITIONS	54
6.1.5 TEST RESULTS	55
<b>7 . 100 KHZ BANDWIDTH OF FREQUENCY BAND EDGE</b>	<b>56</b>
7.1 DEVIATION FROM STANDARD	56
7.2 TEST SETUP	56
7.3 EUT OPERATION CONDITIONS	56
7.4 TEST RESULTS	57
<b>8 . ANTENNA REQUIREMENT</b>	<b>63</b>
8.1 STANDARD REQUIREMENT	63
8.2 EUT ANTENNA	63
<b>9 . EUT TEST PHOTO</b>	<b>64</b>
<b>APPENDIX-PHOTOGRAPHS OF EUT CONSTRUCTIONAL DETAILS</b>	

### 1. SUMMARY OF TEST RESULTS

Test procedures according to the technical standards:

FCC Part15 (15.247) , Subpart C			
Standard Section	Test Item	Judgment	Remark
15.207	Conducted Emission	PASS	
15.247 (a)(2)	6dB Bandwidth	PASS	
15.247 (b)	Peak Output Power	PASS	
15.247 (c)	Radiated Spurious Emission	PASS	
15.247 (d)	Power Spectral Density	PASS	
15.205	Band Edge Emission	PASS	
15.203	Antenna Requirement	PASS	

**NOTE:**

(1) "N/A" denotes test is not applicable in this Test Report

**1.1 TEST FACILITY**

NTEK Testing Technology Co., Ltd  
 Add.:1/F, Building E, Fenda Science Park, Sanwei Community, Xixiang Street, Bao'an District, Shenzhen P.R. China.  
 FCC Registration No.:238937; IC Registration No.:9270A-1  
 CNAS Registration No.:L5516

**1.2 MEASUREMENT UNCERTAINTY**

The reported uncertainty of measurement  $y \pm U$ , where expanded uncertainty  $U$  is based on a standard uncertainty multiplied by a coverage factor of  $k=2$ , providing a level of confidence of approximately 95 %.

No.	Item	Uncertainty
1	Conducted Emission Test	±1.38dB
2	RF power,conducted	±0.16dB
3	Spurious emissions,conducted	±0.21dB
4	All emissions,radiated(<1G)	±4.68dB
5	All emissions,radiated(>1G)	±4.89dB
6	Temperature	±0.5°C
7	Humidity	±2%

## 2. GENERAL INFORMATION

### 2.1 GENERAL DESCRIPTION OF EUT

Equipment	Tablet PC	
Trade Name		
Model Name	EGD103	
Serial Model	HS-10DTB5-4GB,HS-10DTB5-8GB, HS-10DTB5-16GB,HS-10DTB5-32GB	
Model Difference	All the models are the same circuit and RF module, except the model names and colours.	
Product Description	The EUT is a Tablet PC	
	Operation Frequency:	802.11b/g/n(20MHz):2412~2462 MHz 802.11n(40MHz):2422~2452 MHz
	Modulation Type:	CCK/OFDM/DBPSK/DAPSK
	Bit Rate of Transmitter	802.11b:11/5.5/2/1 Mbps 802.11g:54/48/36/24/18/12/9/6Mbps 802.11n(20MHz):150/144.44/130/117/115.56/104/86.67/78/52/6.5Mbps 802.11n(40MHz):300/270/240/180/150/120/108/90/54 Mbps
	Number Of Channel	802.11b/g/n20MHz:11CH 802.11n40MHz:7CH
	Antenna Designation:	Please see Note 3.
	Output Power(Conducted):	802.11b: 12.67 dBm (Max.) 802.11g: 10.57dBm (Max.) 802.11n(20M) : 10.46 dBm (Max.) 802.11n(40M) : 8.46 dBm (Max.)
	Antenna Gain (dBi)	2.0dbi
	Based on the application, features, or specification exhibited in User's Manual, the EUT is considered as an ITE/Computing Device. More details of EUT technical specification, please refer to the User's Manual.	
	Channel List	Please refer to the Note 2.
Ratings	DC 5V, 2A	
Adapter	Model No.:XHY050200LUCH AC Power Input: 100-240V~, 50/60Hz, Max. 0.5A Output: 5V $\overline{\text{---}}$ , 2.0A	
Battery	DC 3.7V, 2800mAh	

Note:

1. For a more detailed features description, please refer to the manufacturer's specifications or the User's Manual.

2.

Channel List for 802.11b/g/n(20)							
Channel	Frequency (MHz)	Channel	Frequency (MHz)	Channel	Frequency (MHz)	Channel	Frequency (MHz)
01	2412	04	2427	07	2442	10	2457
02	2417	05	2432	08	2447	11	2462
03	2422	06	2437	09	2452		

Channel List for 802.11n(40MHz)							
Channel	Frequency (MHz)	Channel	Frequency (MHz)	Channel	Frequency (MHz)	Channel	Frequency (MHz)
03	2422	06	2437	09	2452		
04	2427	07	2442				
05	2432	08	2447				

3.

Table for Filed Antenna

Ant	Brand	Model Name	Antenna Type	Connector	Gain (dBi)	NOTE
A	N/A	N/A	FPCB Antenna	N/A	2.0	Wifi Antenna



## 2.2 DESCRIPTION OF TEST MODES

To investigate the maximum EMI emission characteristics generates from EUT, the test system was pre-scanning tested base on the consideration of following EUT operation mode or test configuration mode which possible have effect on EMI emission level. Each of these EUT operation mode(s) or test configuration mode(s) mentioned above was evaluated respectively.

Pretest Mode	Description
Mode 1	802.11b CH1/ CH6/ CH11
Mode 2	802.11g CH1/ CH6/ CH11
Mode 3	802.11n/20MHz CH1/ CH6/ CH11
Mode 4	802.11n/40MHz CH3/ CH6/ CH9
Mode 5	Link Mode

For Conducted Emission	
Final Test Mode	Description
Mode 5	Link Mode

For Radiated Emission	
Final Test Mode	Description
Mode 1	802.11b CH1/ CH6/ CH11
Mode 2	802.11g CH1/ CH6/ CH11
Mode 3	802.11n/20MHz CH1/ CH6/ CH11
Mode 4	802.11n/40MHz CH3/ CH6/ CH9

Note:

- (1) The measurements are performed at the highest, middle, lowest available channels.
- (2) The measurements are performed at all Bit Rate of Transmitter, the worst data was reported

### 2.3 BLOCK DIGRAM SHOWING THE CONFIGURATION OF SYSTEM TESTED

Conducted Emission Test

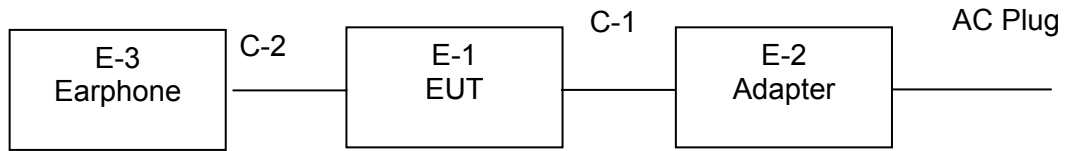

Radiated Spurious Emission Test

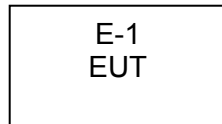

**2.4 DESCRIPTION OF SUPPORT UNITS(CONDUCTED MODE)**

The EUT has been tested as an independent unit together with other necessary accessories or support units. The following support units or accessories were used to form a representative test configuration during the tests.

Item	Equipment	Brand	Model/Type No.	Series No.	Note
E-1	Tablet PC	N/A	EGD103	N/A	EUT
E-2	Adapter	N/A	XHY0520LUCH	N/A	
E-3	Earphone	N/A	2368	N/A	

Item	Shielded Type	Ferrite Core	Length	Note
C-1	NO	NO	100cm	
C-2	NO	NO	80cm	

Note:

- (1) The support equipment was authorized by Declaration of Confirmation.
- (2) For detachable type I/O cable should be specified the length in cm in 『Length』 column.

## 2.5 EQUIPMENTS LIST FOR ALL TEST ITEMS

### Radiation Test equipment

Item	Kind of Equipment	Manufacturer	Type No.	Serial No.	Last calibration	Calibrated until	Calibration period
1	Spectrum Analyzer	Agilent	E4407B	MY45108040	2013.07.06	2014.07.05	1 year
2	Test Receiver	R&S	ESPI	101318	2013.06.07	2014.06.06	1 year
3	Bilog Antenna	TESEQ	CBL6111D	31216	2013.07.06	2014.07.05	1 year
4	50Ω Coaxial Switch	Anritsu	MP59B	6200264416	2013.06.07	2014.06.06	1 year
5	Spectrum Analyzer	ADVANTEST	R3132	150900201	2013.06.07	2014.06.06	1 year
6	Horn Antenna	EM	EM-AH-10180	2011071402	2013.07.06	2014.07.05	1 year
7	Horn Ant	Schwarzbeck	BBHA 9170	9170-181	2013.07.06	2014.07.05	1 year
8	Amplifier	EM	EM-30180	060538	2012.12.22	2013.12.21	1 year
9	Loop Antenna	ARA	PLA-1030/B	1029	2013.06.08	2014.06.07	1 year
10	Power Meter	R&S	NRVS	100696	2013.07.06	2014.07.05	1 year
11	Power Sensor	R&S	URV5-Z4	0395.1619.05	2013.07.06	2014.07.05	1 year

### Conduction Test equipment

Item	Kind of Equipment	Manufacturer	Type No.	Serial No.	Last calibration	Calibrated until	Calibration period
1	Test Receiver	R&S	ESCI	101160	2013.06.06	2014.06.05	1 year
2	LISN	R&S	ENV216	101313	2013.08.24	2014.08.23	1 year
3	LISN	EMCO	3816/2	00042990	2013.08.24	2014.08.23	1 year
4	50Ω Coaxial Switch	Anritsu	MP59B	6200264417	2013.06.07	2014.06.06	1 year
5	Passive Voltage Probe	R&S	ESH2-Z3	100196	2013.06.07	2014.06.06	1 year
6	Absorbing clamp	R&S	MOS-21	100423	2013.06.08	2014.06.07	1 year

1	Attenuation	MCE	24-10-34	BN9258	2013.06.08	2014.06.07	1 year
---	-------------	-----	----------	--------	------------	------------	--------

### 3. EMC EMISSION TEST

#### 3.1 CONDUCTED EMISSION MEASUREMENT

##### 3.1.1 POWER LINE CONDUCTED EMISSION Limits (Frequency Range 150KHz-30MHz)

FREQUENCY (MHz)	Class A (dBuV)		Class B (dBuV)		Standard
	Quasi-peak	Average	Quasi-peak	Average	
0.15 -0.5	79.00	66.00	66 - 56 *	56 - 46 *	CISPR
0.50 -5.0	73.00	60.00	56.00	46.00	CISPR
5.0 -30.0	73.00	60.00	60.00	50.00	CISPR

0.15 -0.5	79.00	66.00	66 - 56 *	56 - 46 *	FCC
0.50 -5.0	73.00	60.00	56.00	46.00	FCC
5.0 -30.0	73.00	60.00	60.00	50.00	FCC

Note:

- (1) The tighter limit applies at the band edges.
- (2) The limit of " \* " marked band means the limitation decreases linearly with the logarithm of the frequency in the range.

The following table is the setting of the receiver

Receiver Parameters	Setting
Attenuation	10 dB
Start Frequency	0.15 MHz
Stop Frequency	30 MHz
IF Bandwidth	9 kHz

**3.1.2 TEST PROCEDURE**

- a. The EUT was placed 0.8 meters from the horizontal ground plane with EUT being connected to the power mains through a line impedance stabilization network (LISN). All other support equipments powered from additional LISN(s). The LISN provide 50 Ohm/ 50uH of coupling impedance for the measuring instrument.
- b. Interconnecting cables that hang closer than 40 cm to the ground plane shall be folded back and forth in the center forming a bundle 30 to 40 cm long.
- c. I/O cables that are not connected to a peripheral shall be bundled in the center. The end of the cable may be terminated, if required, using the correct terminating impedance. The overall length shall not exceed 1 m.
- d. LISN at least 80 cm from nearest part of EUT chassis.
- e. For the actual test configuration, please refer to the related Item –EUT Test Photos.

**3.1.3 DEVIATION FROM TEST STANDARD**

No deviation

**3.1.4 TEST SETUP**

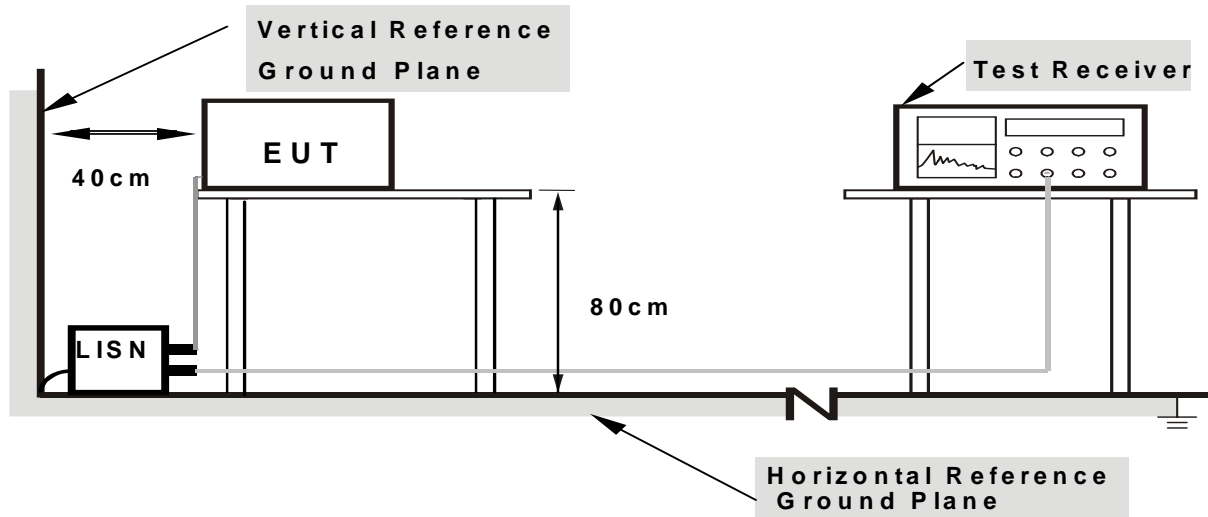

- Note:**
- 1. Support units were connected to second LISN.
  - 2. Both of LISNs (AMN) are 80 cm from EUT and at least 80 from other units and other metal planes

**3.1.5 EUT OPERATING CONDITIONS**

The EUT was configured for testing in a typical fashion (as a customer would normally use it). The EUT has been programmed to continuously transmit during test. This operating condition was tested and used to collect the included data.

### 3.1.6 TEST RESULTS

EUT :	Tablet PC	Model Name. :	EGD103
Temperature :	26 °C	Relative Humidity :	54%
Pressure :	1010hPa	Phase :	L
Test Voltage :	DC 5V from adapter AC 120V/60Hz	Test Mode :	Mode 5

Frequency (MHz)	Meter Reading (dBμV)	Factor (dB)	Emission Level (dBμV)	Limits (dBμV)	Margin (dB)	Detector Type
0.1819	48.77	9.54	58.31	64.39	-6.08	QP
0.1819	34.58	9.54	44.12	54.39	-10.27	AVG
0.2419	43.27	9.49	52.76	62.03	-9.27	QP
0.2419	32.73	9.49	42.22	52.03	-9.81	AVG
0.5460	29.00	9.51	38.51	56.00	-17.49	QP
0.5460	22.17	9.51	31.68	46.00	-14.32	AVG
2.1860	30.20	9.55	39.75	56.00	-16.25	QP
2.1860	23.55	9.55	33.10	46.00	-12.9	AVG
3.9500	24.74	9.59	34.33	56.00	-21.67	QP
3.9500	17.19	9.59	26.78	46.00	-19.22	AVG
24.0020	16.55	10.21	26.76	60.00	-33.24	QP
24.0020	10.86	10.21	21.07	50.00	-28.93	AVG

**Remark:**

1. All readings are Quasi-Peak and Average values.
2. Factor = Insertion Loss + Cable Loss.

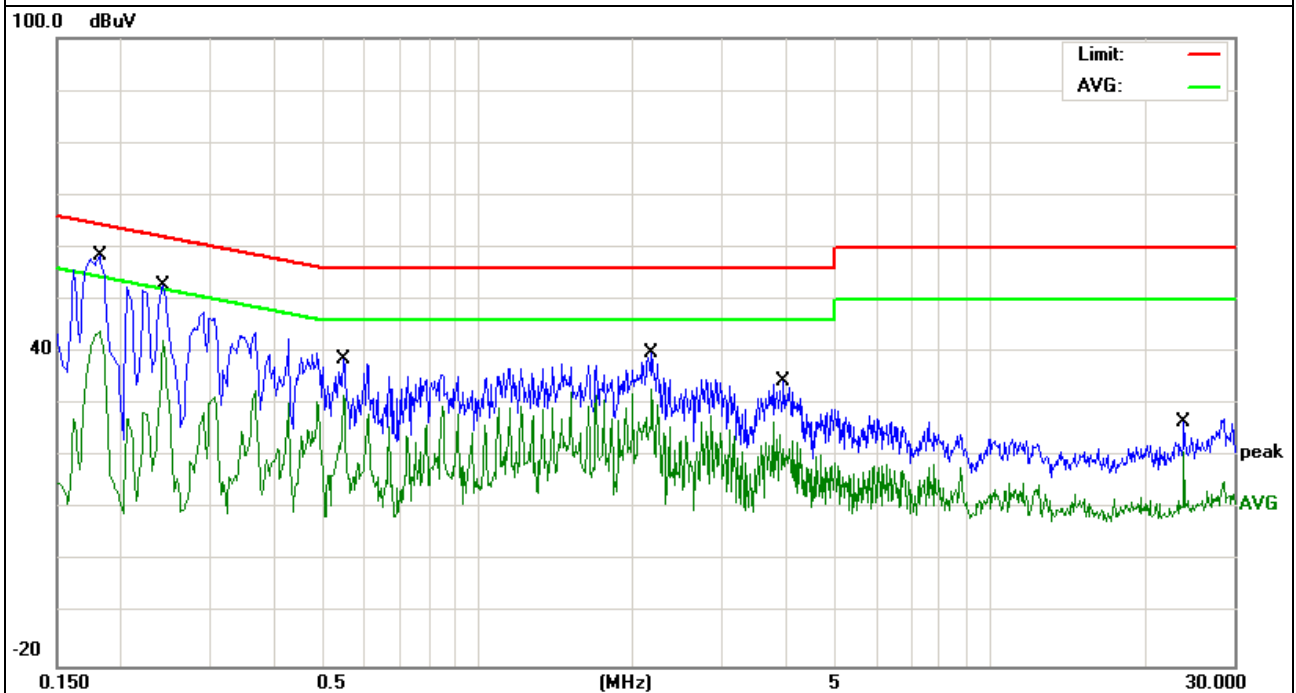

EUT :	Tablet PC	Model Name. :	EGD103
Temperature :	26 °C	Relative Humidity :	54%
Pressure :	1010hPa	Phase :	N
Test Voltage :	DC 5V from adapter AC 120V/60Hz	Test Mode :	Mode 5

Frequency (MHz)	Meter Reading (dBμV)	Factor (dB)	Emission Level (dBμV)	Limits (dBμV)	Margin (dB)	Detector Type
0.1779	46.91	9.56	56.47	64.58	-8.11	QP
0.1779	33.19	9.56	42.75	54.58	-11.83	AVG
0.2220	42.03	9.49	51.52	62.74	-11.22	QP
0.2220	24.26	9.49	33.75	52.74	-18.99	AVG
0.4620	31.21	9.51	40.72	56.66	-15.94	QP
0.4620	16.79	9.51	26.30	46.66	-20.36	AVG
2.1259	30.79	9.55	40.34	56.00	-15.66	QP
2.1259	23.57	9.55	33.12	46.00	-12.88	AVG
5.8299	20.01	9.64	29.65	60.00	-30.35	QP
5.8299	5.75	9.64	15.39	50.00	-34.61	AVG
23.9980	20.84	10.21	31.05	60.00	-28.95	QP
23.9980	13.87	10.21	24.08	50.00	-25.92	AVG

Remark:

1. All readings are Quasi-Peak and Average values.
2. Factor = Insertion Loss + Cable Loss.

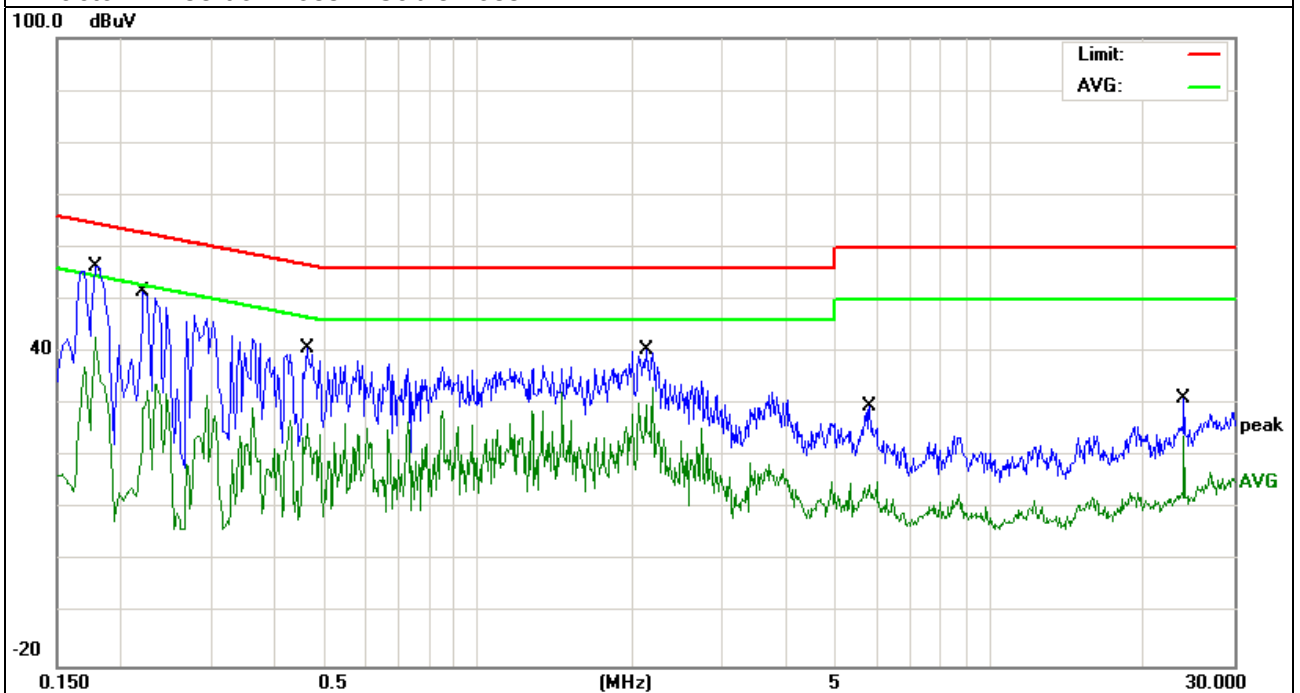



### 3.2 RADIATED EMISSION MEASUREMENT

#### 3.2.1 RADIATED EMISSION LIMITS (Frequency Range 9kHz-1000MHz)

20dBc in any 100 kHz bandwidth outside the operating frequency band. In case the emission fall within the restricted band specified on 15.205(a), then the 15.209(a) limit in the table below has to be followed.

Frequencies (MHz)	Field Strength (microrvolts/meter)	Measurement Distance (meters)
0.009~0.490	2400/F(KHz)	300
0.490~1.705	24000/F(KHz)	30
1.705~30.0	30	30
30~88	100	3
88~216	150	3
216~960	200	3
Above 960	500	3

#### LIMITS OF RADIATED EMISSION MEASUREMENT (Above 1000MHz)

FREQUENCY (MHz)	Class A (dBuV/m) (at 3M)		Class B (dBuV/m) (at 3M)	
	PEAK	AVERAGE	PEAK	AVERAGE
Above 1000	80	60	74	54

Notes:

- (1) The limit for radiated test was performed according to FCC PART 15C.
- (2) The tighter limit applies at the band edges.
- (3) Emission level (dBuV/m)=20log Emission level (uV/m).

Spectrum Parameter	Setting
Attenuation	Auto
Start Frequency	1000 MHz
Stop Frequency	10th carrier harmonic
RB / VB (emission in restricted band)	1 MHz / 1 MHz for Peak, 1 MHz / 10Hz for Average

Receiver Parameter	Setting
Attenuation	Auto
Start ~ Stop Frequency	9kHz~150kHz / RB 200Hz for QP
Start ~ Stop Frequency	150kHz~30MHz / RB 9kHz for QP
Start ~ Stop Frequency	30MHz~1000MHz / RB 120kHz for QP

### 3.2.2 TEST PROCEDURE

- a. The measuring distance of at 3 m shall be used for measurements at frequency up to 1GHz. For frequencies above 1GHz, any suitable measuring distance may be used.
- b. The EUT was placed on the top of a rotating table 0.8 meters above the ground at a 3 meter open area test site. The table was rotated 360 degrees to determine the position of the highest radiation.
- c. The height of the equipment or of the substitution antenna shall be 0.8 m; the height of the test antenna shall vary between 1 m to 4 m. Both horizontal and vertical polarizations of the antenna are set to make the measurement.
- d. The initial step in collecting conducted emission data is a Tablet PC analyzer peak detector mode pre-scanning the measurement frequency range. Significant peaks are then marked and then Quasi Peak detector mode re-measured.
- e. If the Peak Mode measured value compliance with and lower than Quasi Peak Mode Limit, the EUT shall be deemed to meet QP Limits and then no additional QP Mode measurement performed.
- f. For the actual test configuration, please refer to the related Item –EUT Test Photos.

Note:

Both horizontal and vertical antenna polarities were tested and performed pretest to three orthogonal axis. The worst case emissions were reported

### 3.2.3 DEVIATION FROM TEST STANDARD

No deviation

**3.2.4 TEST SETUP**

(A) Radiated Emission Test-Up Frequency Below 30MHz

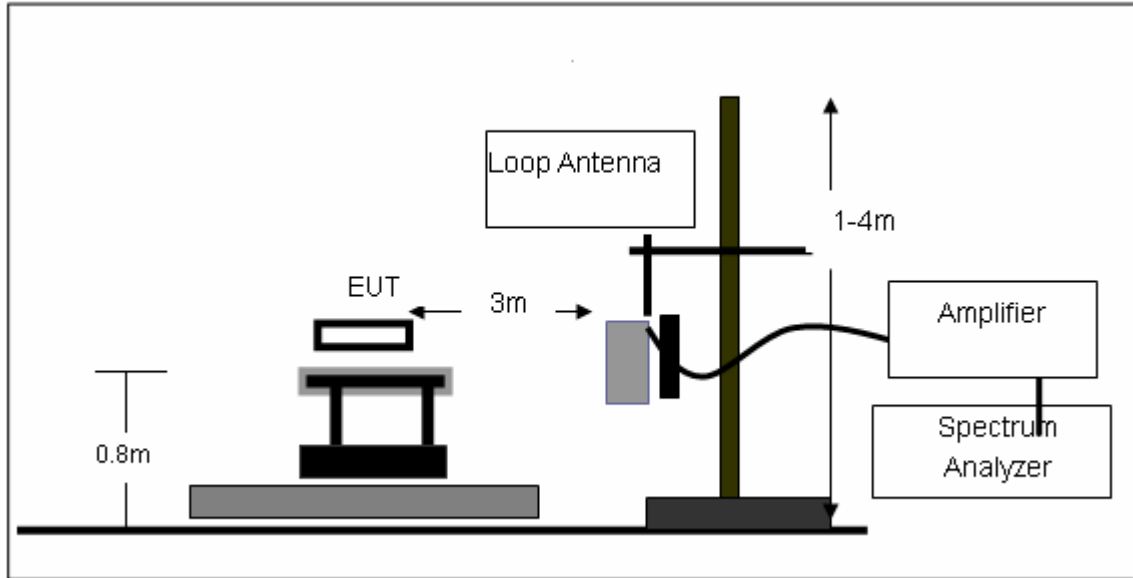

(B) Radiated Emission Test-Up Frequency 30MHz~1GHz

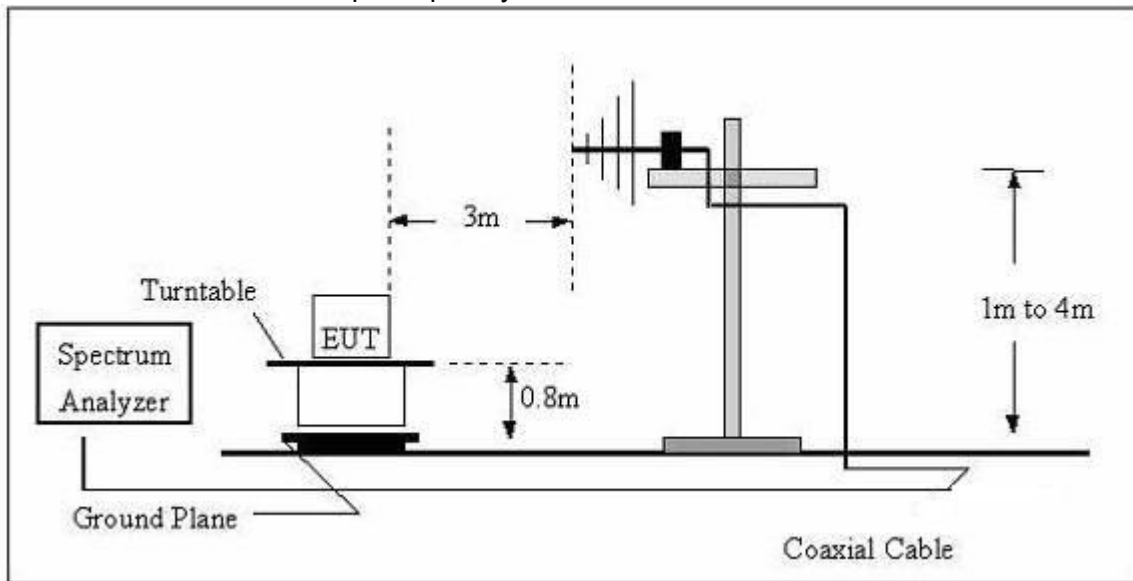

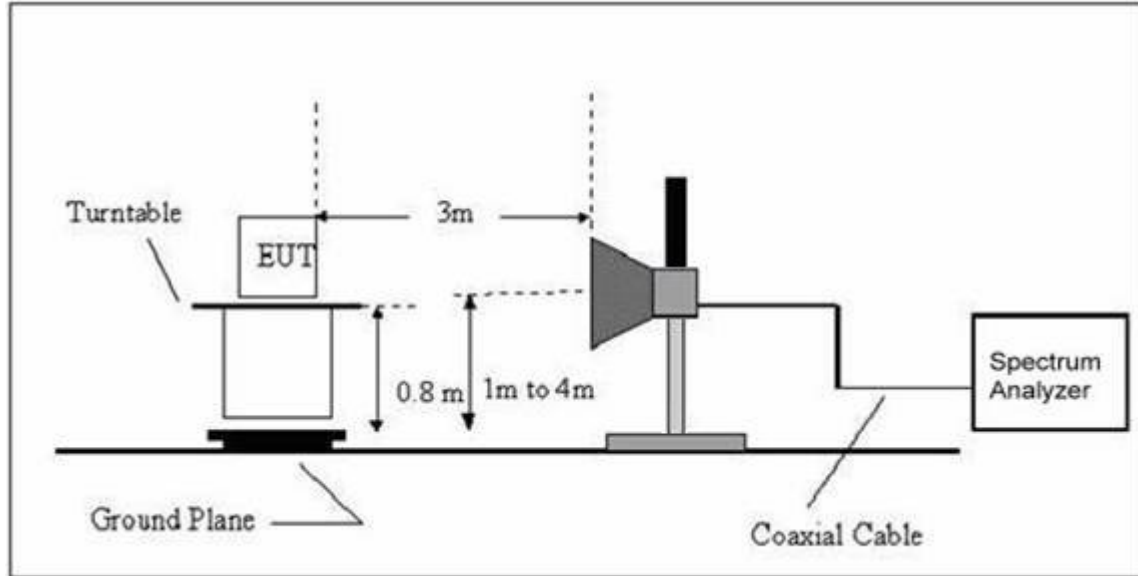
**(C) Radiated Emission Test-Up Frequency Above 1GHz****3.2.5 EUT OPERATING CONDITIONS**

The EUT tested system was configured as the statements of 2.4 Unless otherwise a special operating condition is specified in the follows during the testing.

**3.2.6 TEST RESULTS (BETWEEN 9KHZ – 30 MHZ)**

EUT:	Tablet PC	Model Name. :	EGD103
Temperature:	20 °C	Relative Humidity:	48%
Pressure:	1010 hPa	Test Voltage :	DC 3.7V
Test Mode :	TX	Polarization :	--

Freq.	Reading	Limit	Margin	State
(MHz)	(dBuV/m)	(dBuV/m)	(dB)	P/F
--	--	--	--	PASS
--	--	--	--	PASS

**NOTE:**

The amplitude of spurious emissions which are attenuated by more than 20dB below the permissible value has no need to be reported.

Distance extrapolation factor =  $40 \log (\text{specific distance}/\text{test distance})(\text{dB})$ ;

Limit line = specific limits(dBuv) + distance extrapolation factor.

**3.2.7 TEST RESULTS (BETWEEN 30MHZ – 1GHZ)**

EUT :	Tablet PC	Model Name :	EGD103
Temperature :	20 °C	Relative Humidity :	48%
Pressure:	1010 hPa	Test Voltage :	DC 3.7V
Test Mode:	TX		

Polar (H/V)	Frequency	Meter Reading	Factor	Emission Level	Limits	Margin	Detector Type
	(MHz)	(dBuV)	(dB)	(dBuV/m)	(dBuV/m)	(dB)	
Vertical	63.5356	19.16	5.40	24.56	40.00	-15.44	QP
Vertical	117.3603	15.88	12.02	27.90	43.50	-15.60	QP
Vertical	189.7385	19.72	9.05	28.77	43.50	-14.73	QP
Vertical	268.4852	11.27	14.22	25.49	46.00	-20.51	QP
Vertical	413.2706	8.50	18.83	27.33	46.00	-18.67	QP
Vertical	916.0687	12.42	28.48	40.90	46.00	-5.10	QP
Horizontal	63.5356	12.53	5.40	17.93	40.00	-22.07	QP
Horizontal	75.1821	16.94	6.85	23.79	40.00	-16.21	QP
Horizontal	162.0414	21.15	10.92	32.07	43.50	-11.43	QP
Horizontal	264.7456	23.05	14.53	37.58	46.00	-8.42	QP
Horizontal	396.2414	21.95	18.05	40.00	46.00	-6.00	QP
Horizontal	768.7481	12.93	26.20	39.13	46.00	-6.87	QP

### 3.2.8 TEST RESULTS (ABOVE 1000 MHZ)

EUT :	Tablet PC	Model Name :	EGD103
Temperature :	20 °C	Relative Humidity :	48%
Pressure:	1010 hPa	Test Voltage :	DC 3.7V
Test Mode:	TX		

Low Channel (2412 MHz)-Above 1G							
4823.627	40.51	10.43	50.94	74	-23.06	Pk	Vertical
7236.535	39.22	12.37	51.59	74	-22.41	Pk	Vertical
4824.826	43.39	10.43	53.82	74	-20.18	Pk	Horizontal
7235.357	40.14	12.37	52.51	74	-21.49	Pk	Horizontal
Mid Channel (2437 MHz)-Above 1G							
4874.463	43.33	10.45	53.78	74	-20.22	Pk	Vertical
7311.536	39.65	12.41	52.06	74	-21.94	Pk	Vertical
4876.432	43.28	10.45	53.73	74	-20.27	Pk	Horizontal
7311.454	41.13	12.41	53.54	74	-20.46	Pk	Horizontal
High Channel (2462 MHz)- Above 1G							
4925.543	42.27	10.39	52.66	74	-21.34	Pk	Vertical
7386.334	41.14	12.68	53.82	74	-20.18	Pk	Vertical
4924.264	42.15	10.39	52.54	74	-21.46	Pk	Horizontal
7386.564	41.18	12.68	53.86	74	-20.14	Pk	Horizontal

Note:"802.11b" mode is the worst mode.

PK value is lower than the Average value limit, So average didn't record.

Conducted Spurious Emissions at Antenna Port:  
802.11b Low Channel

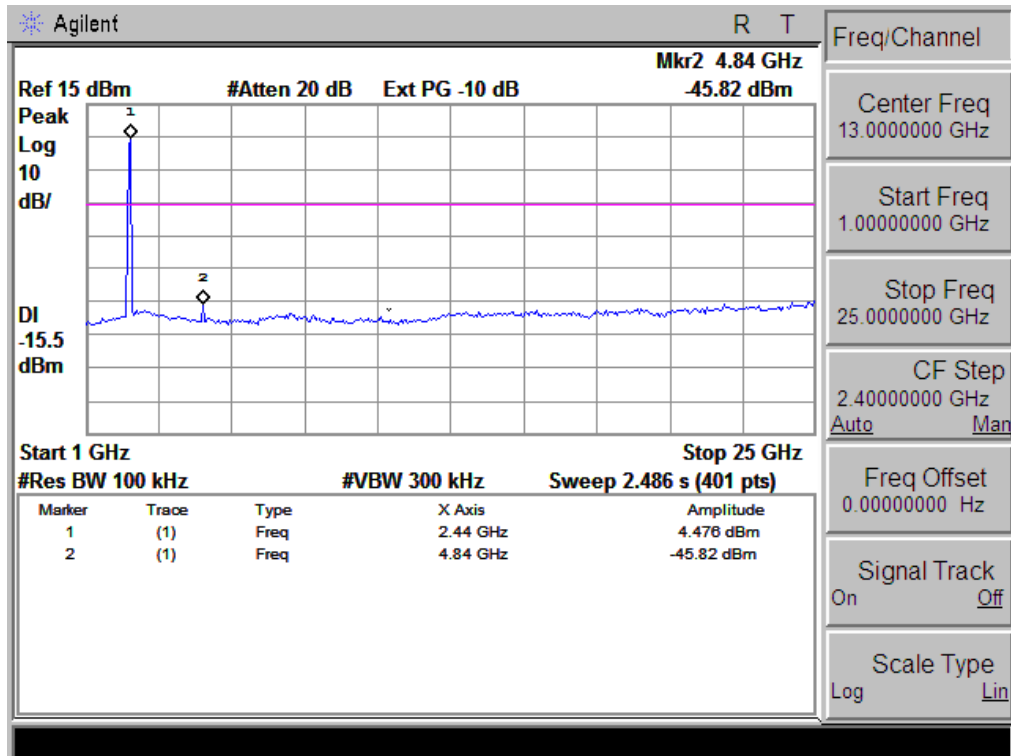
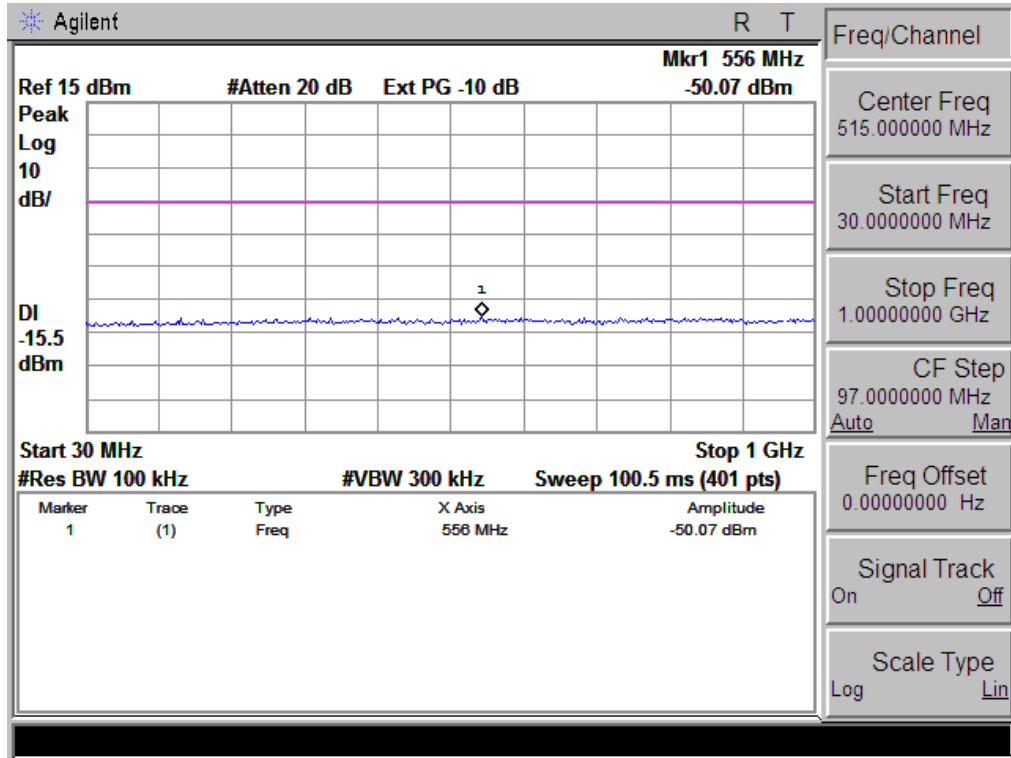



### 802.11b Middle Channel

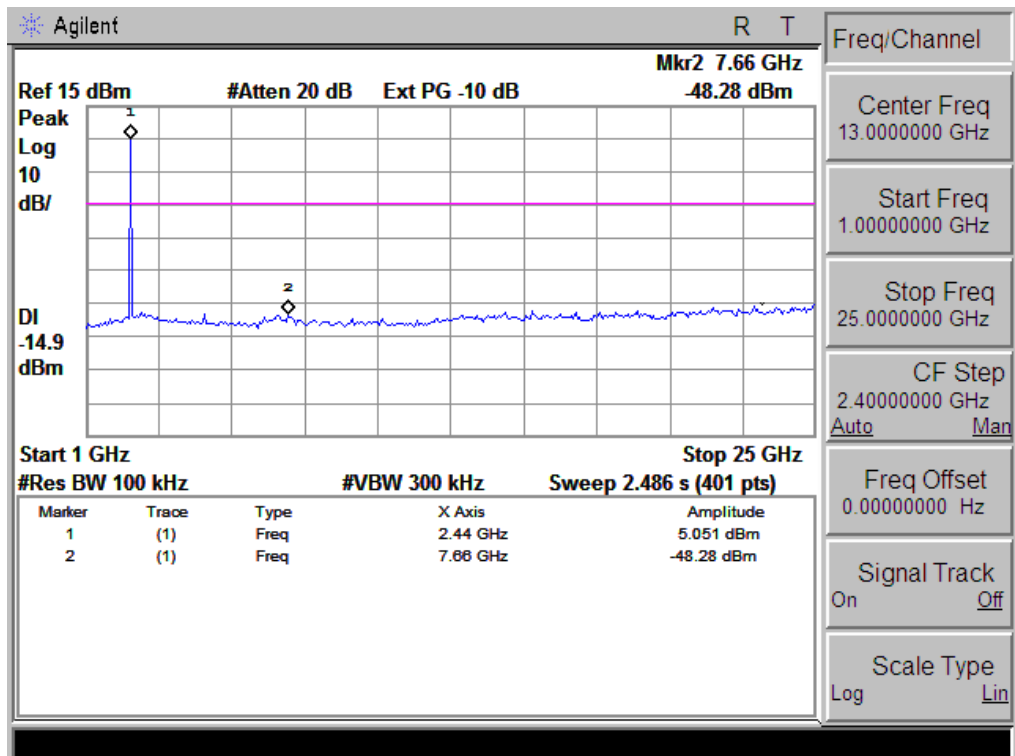
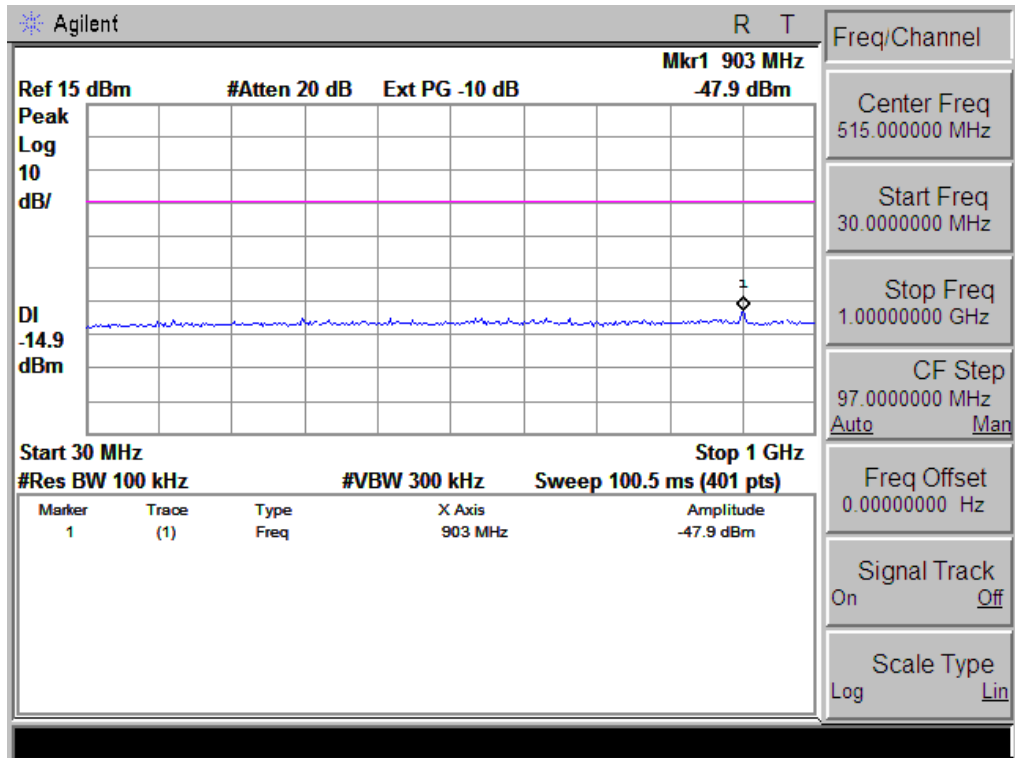

### 802.11b High Channel

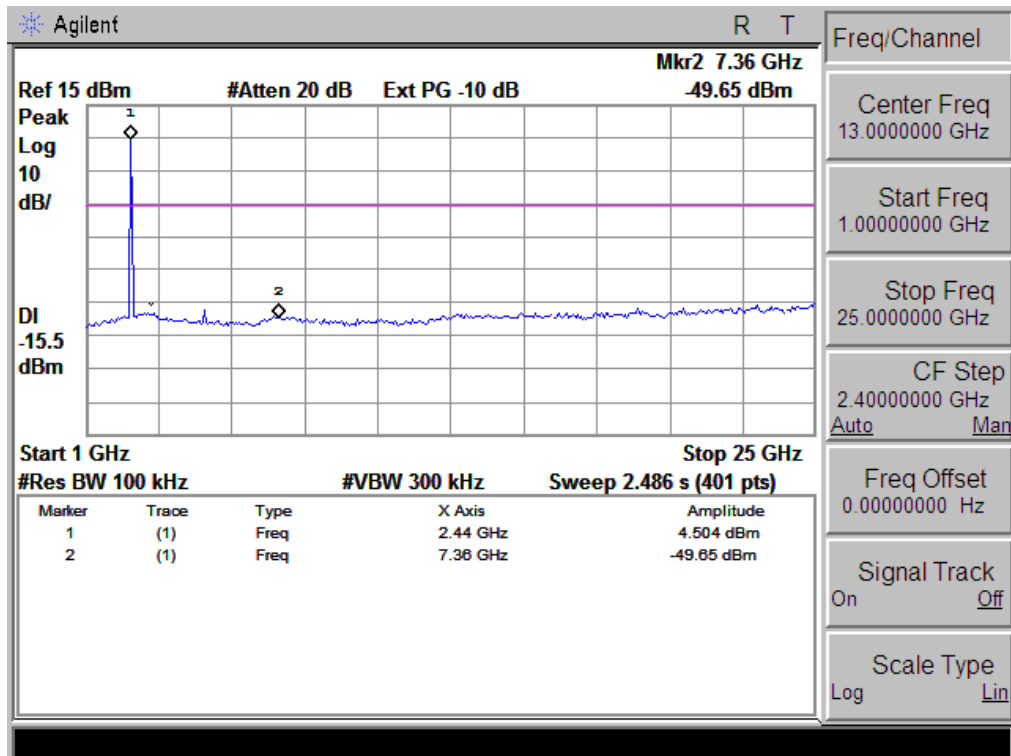
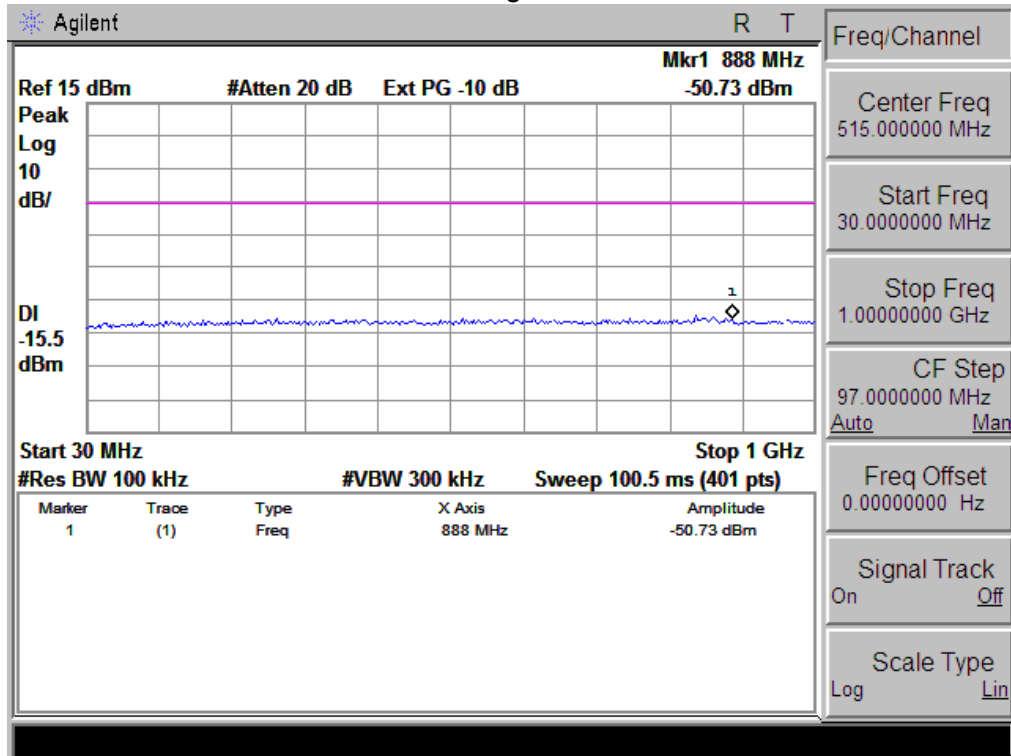

### 802.11g Low Channel

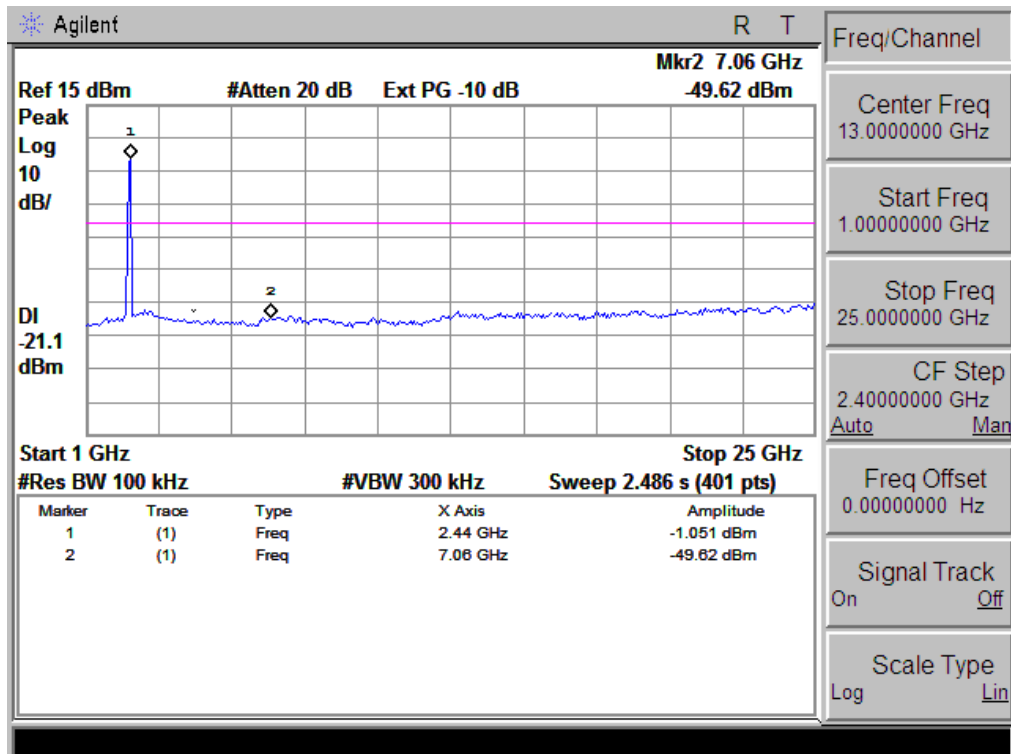
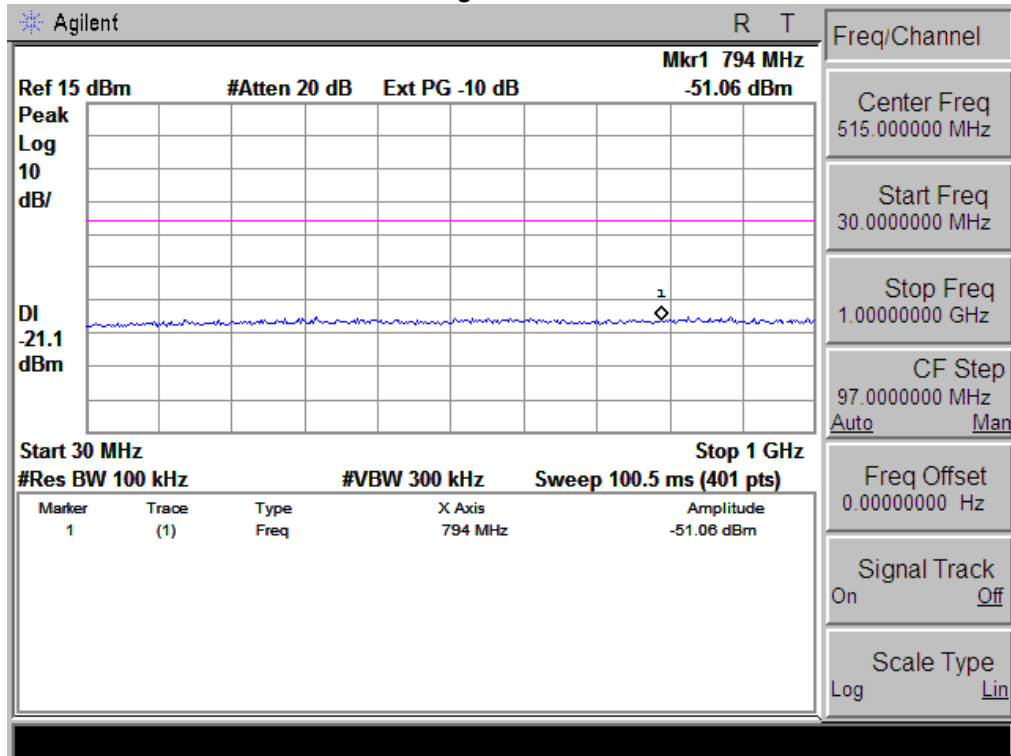

### 802.11g Middle Channel

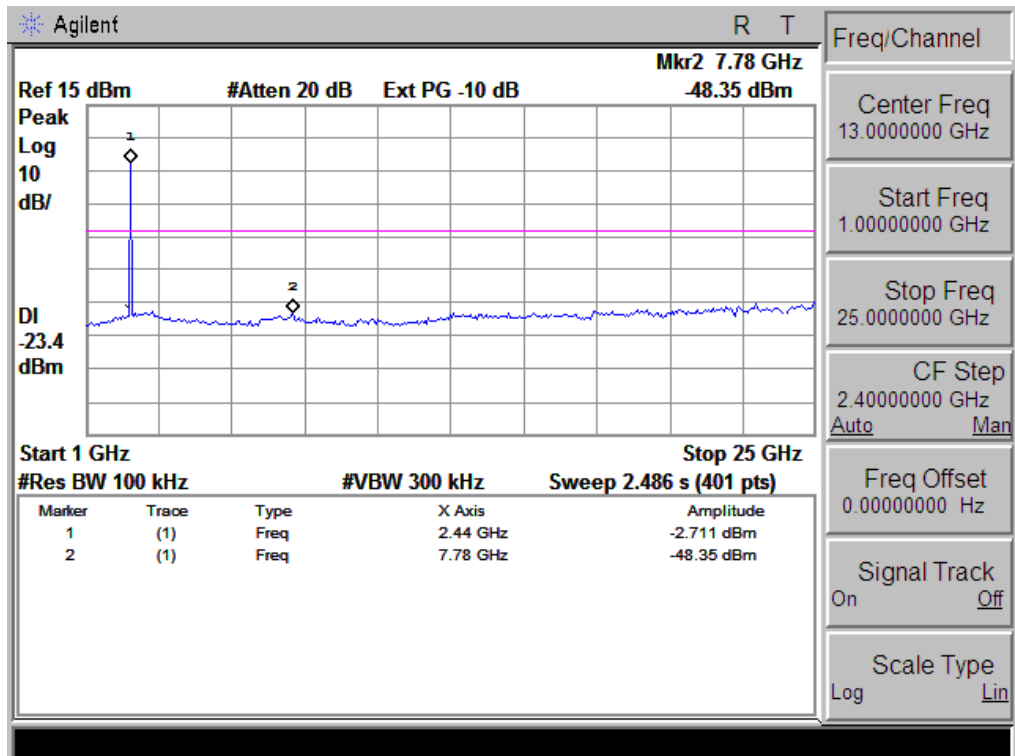
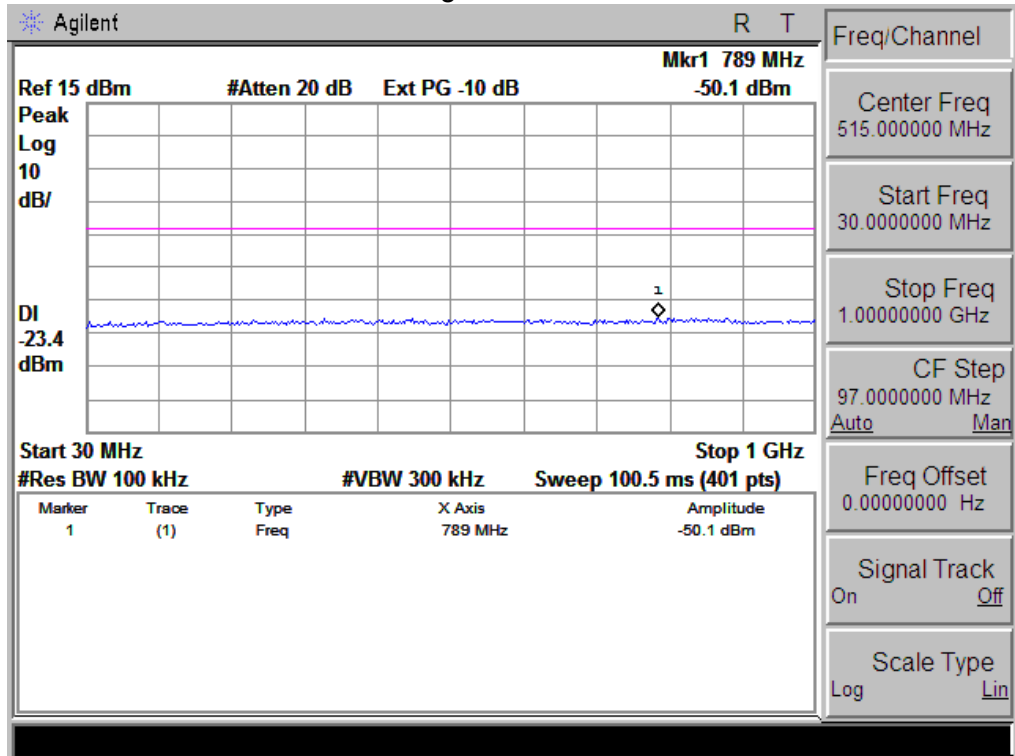

### 802.11g High Channel

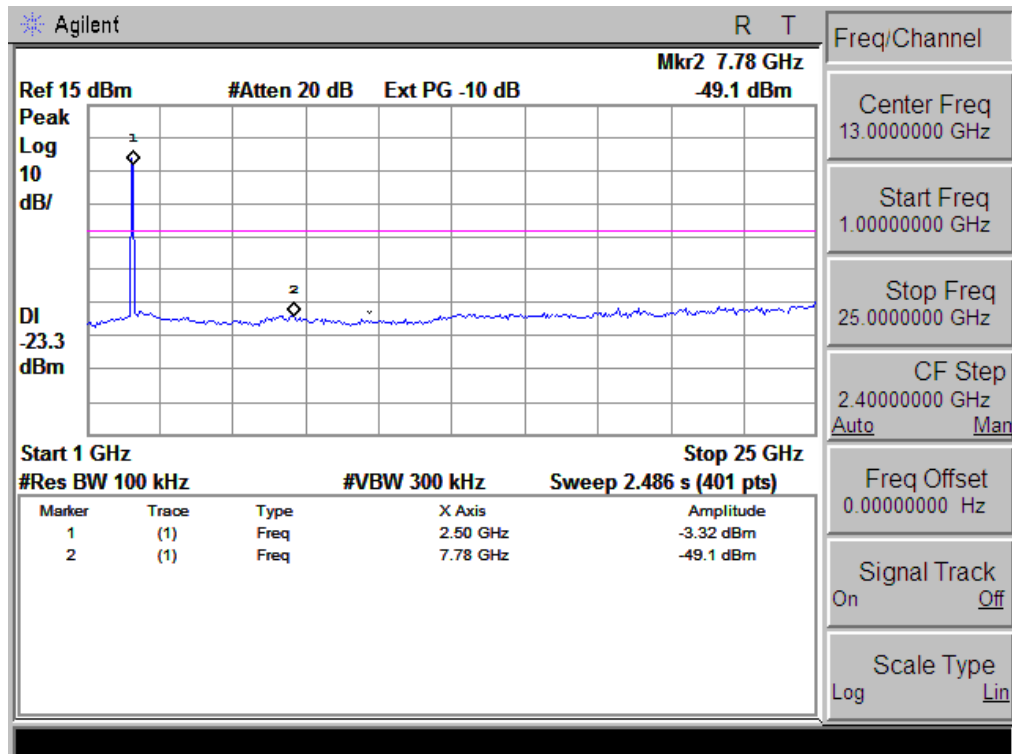
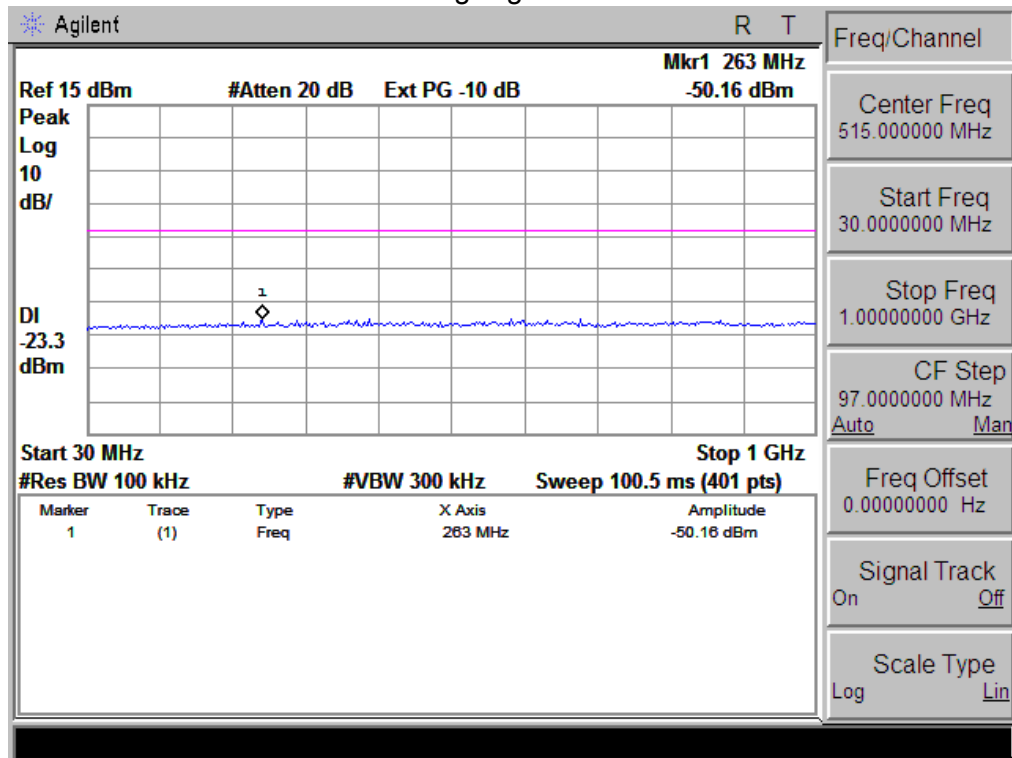

802.11n-HT20 Low Channel

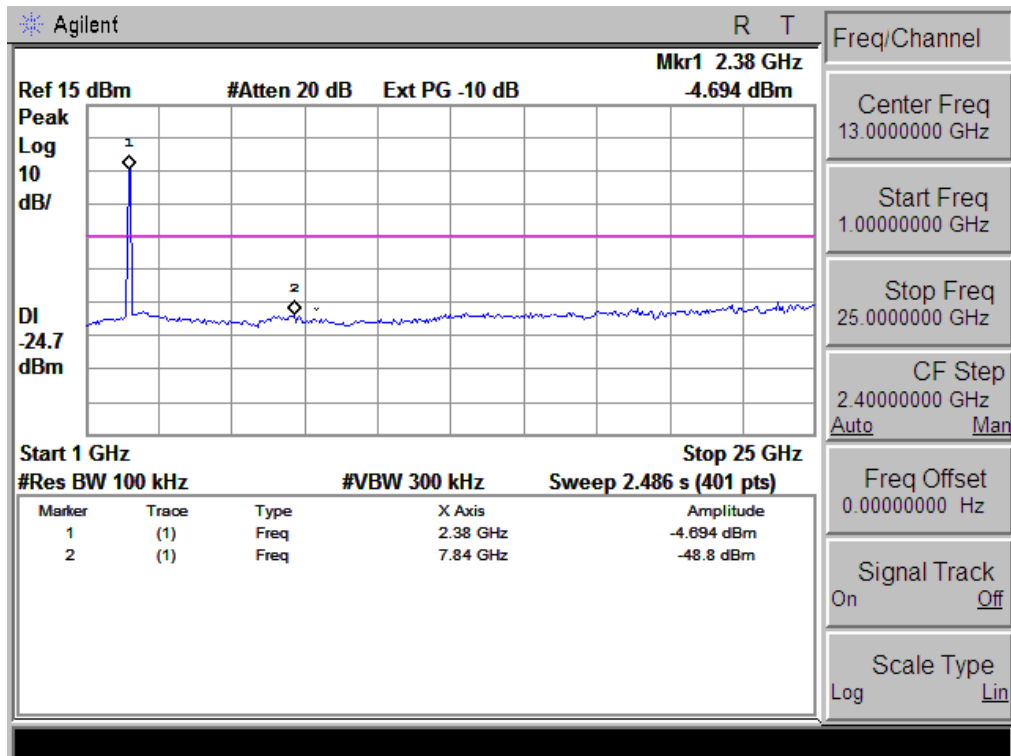
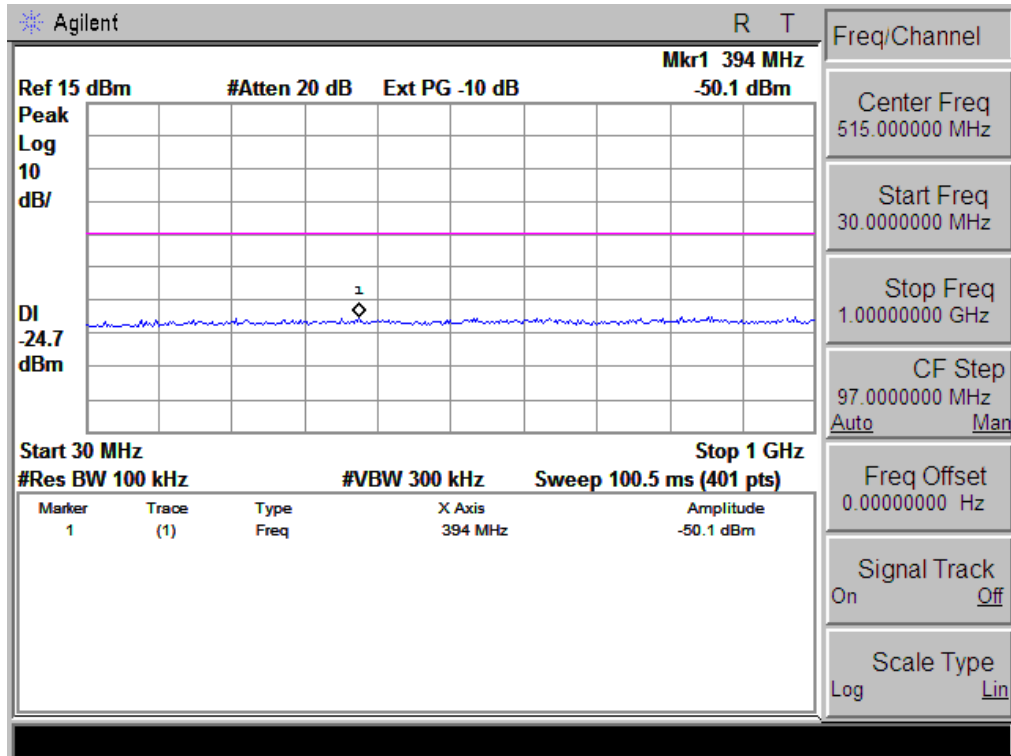

802.11n-HT20 Middle Channel

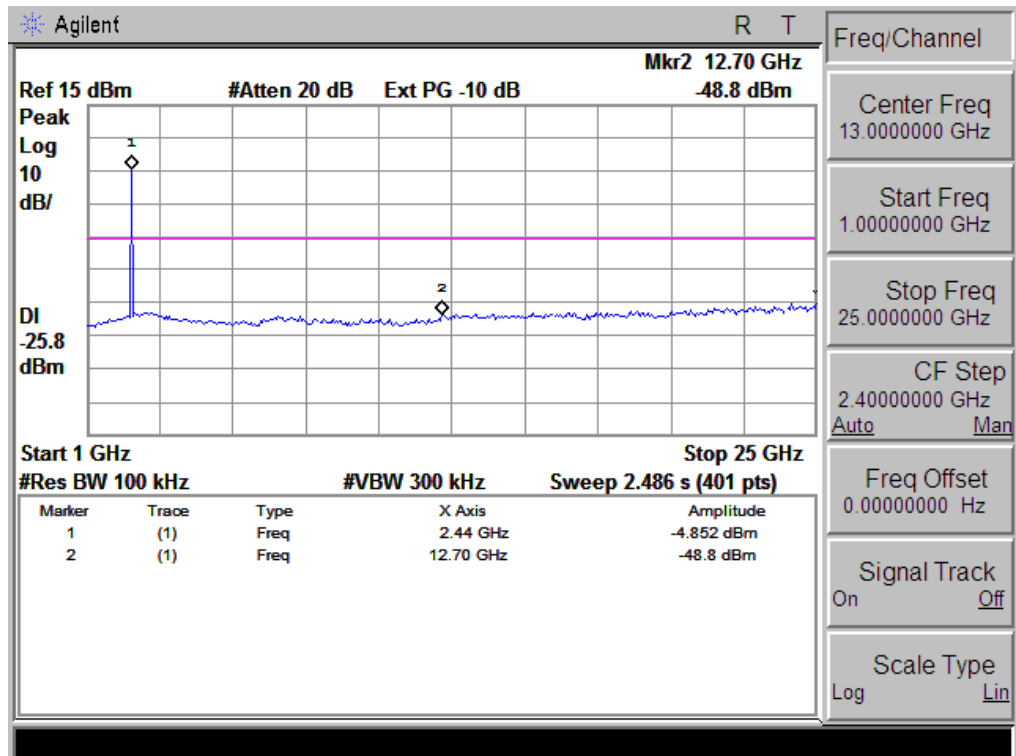
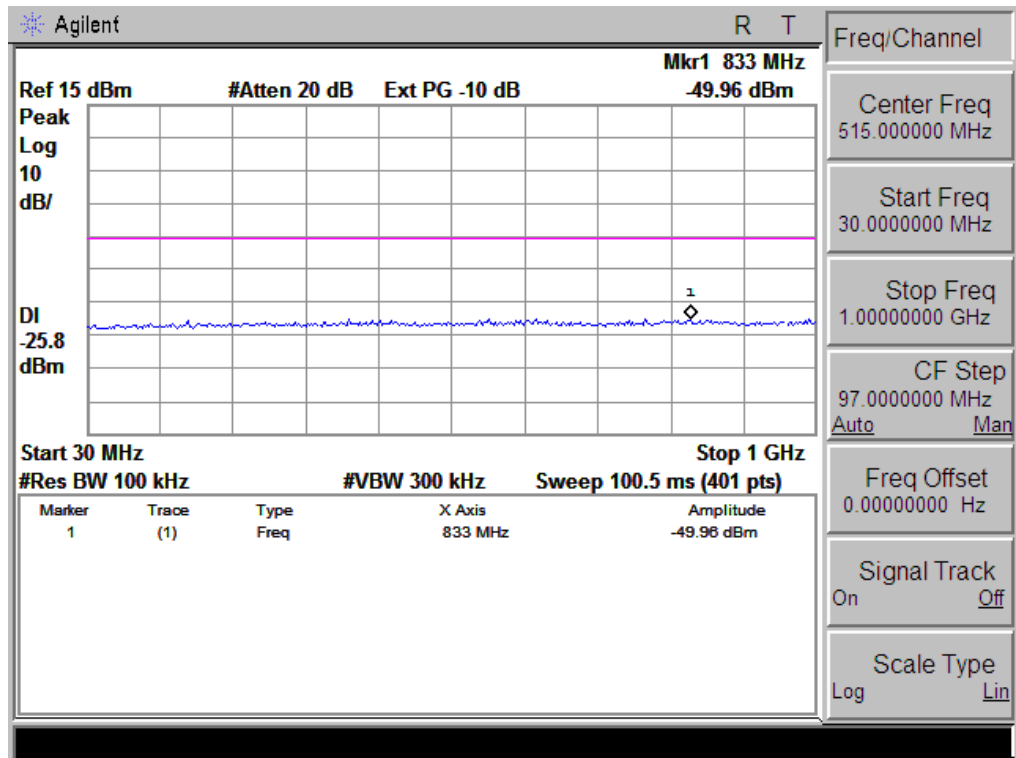

### 802.11n-HT20 High Channel

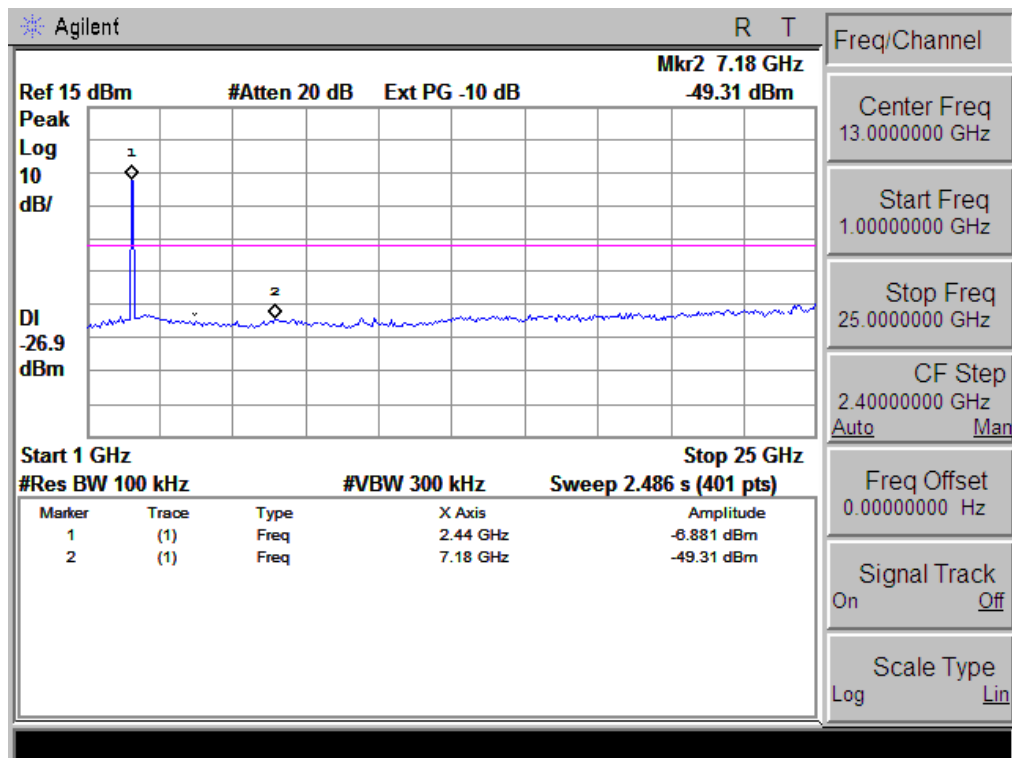
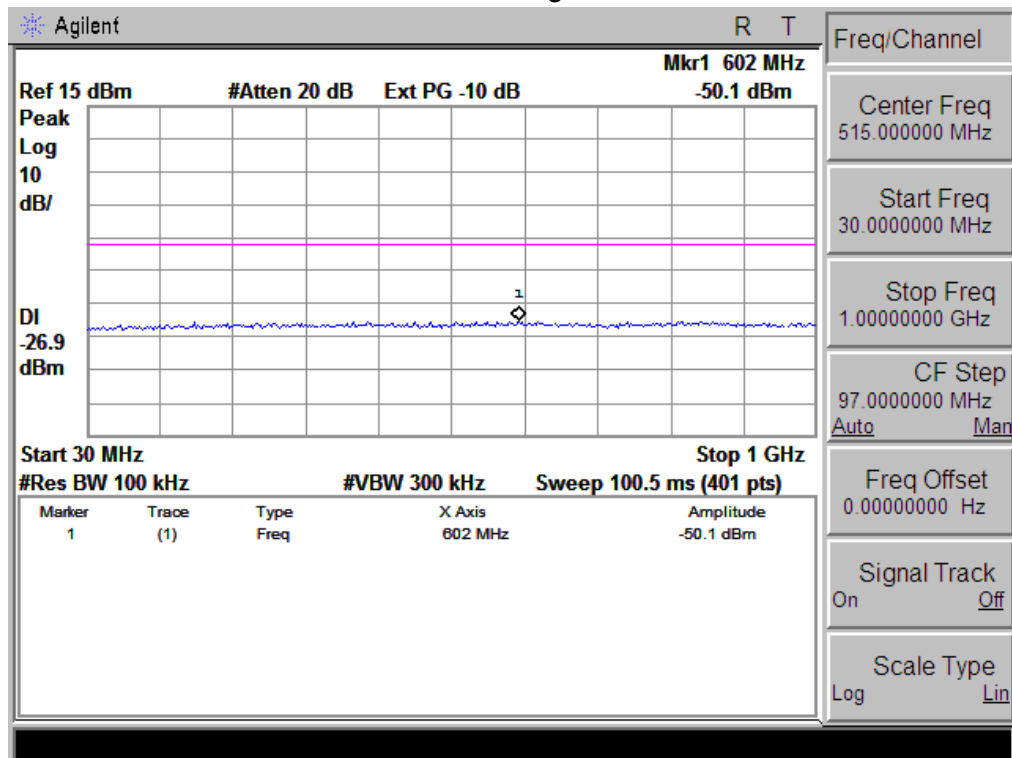



### 802.11n-HT40 Low Channel

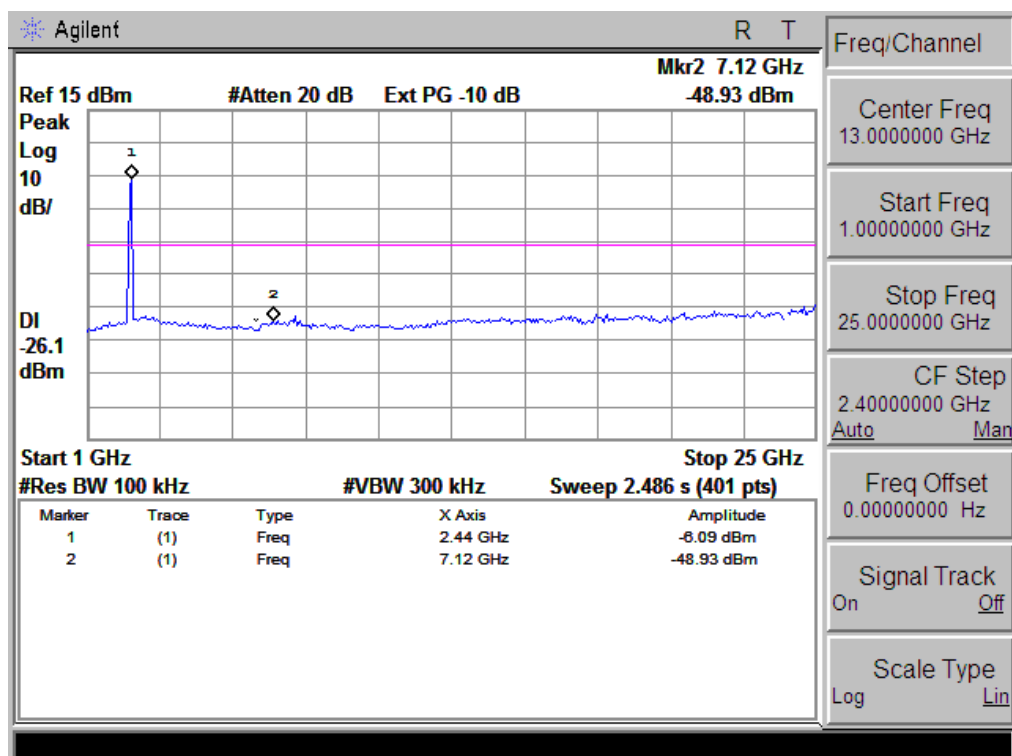
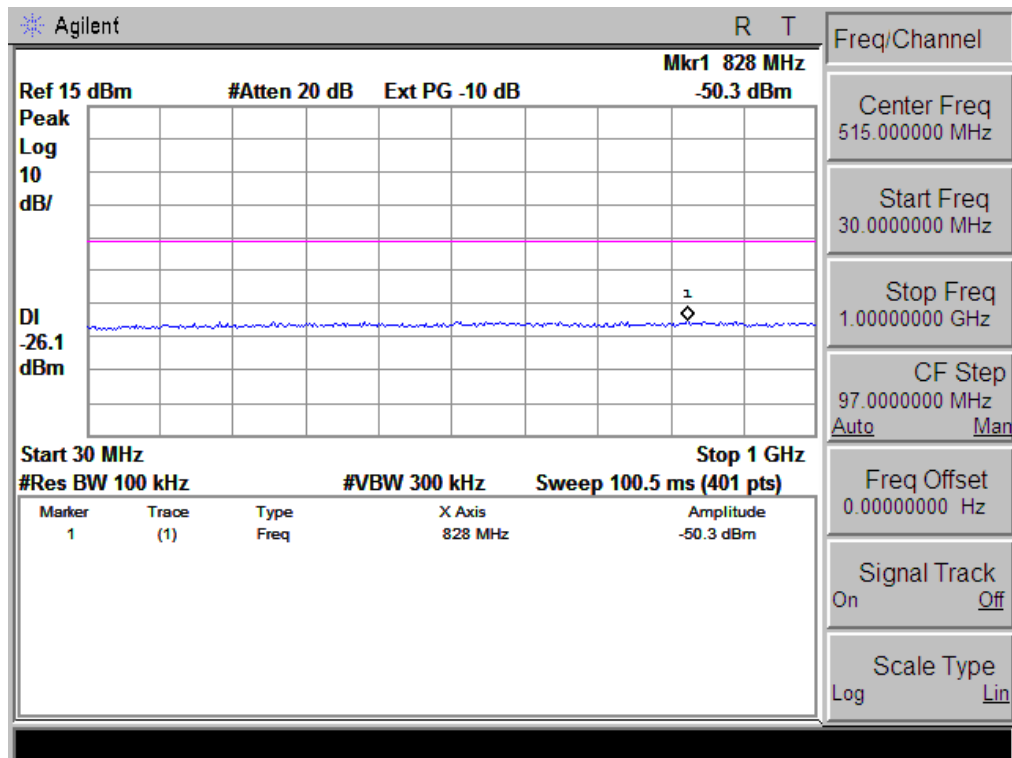

802.11n-HT40 Middle Channel

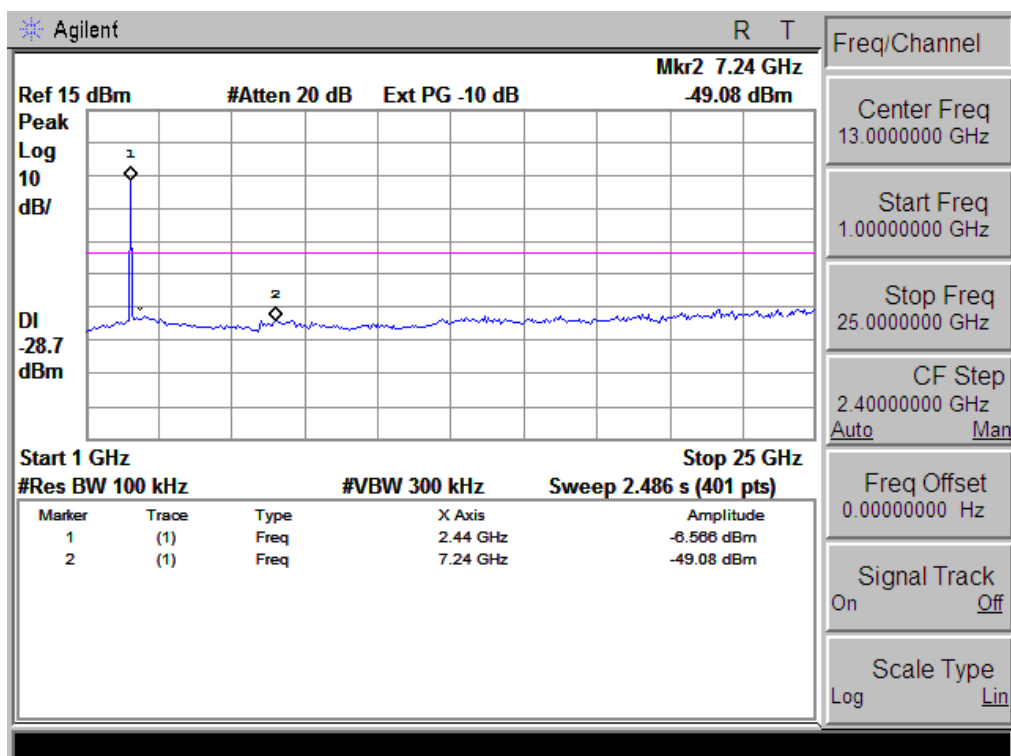
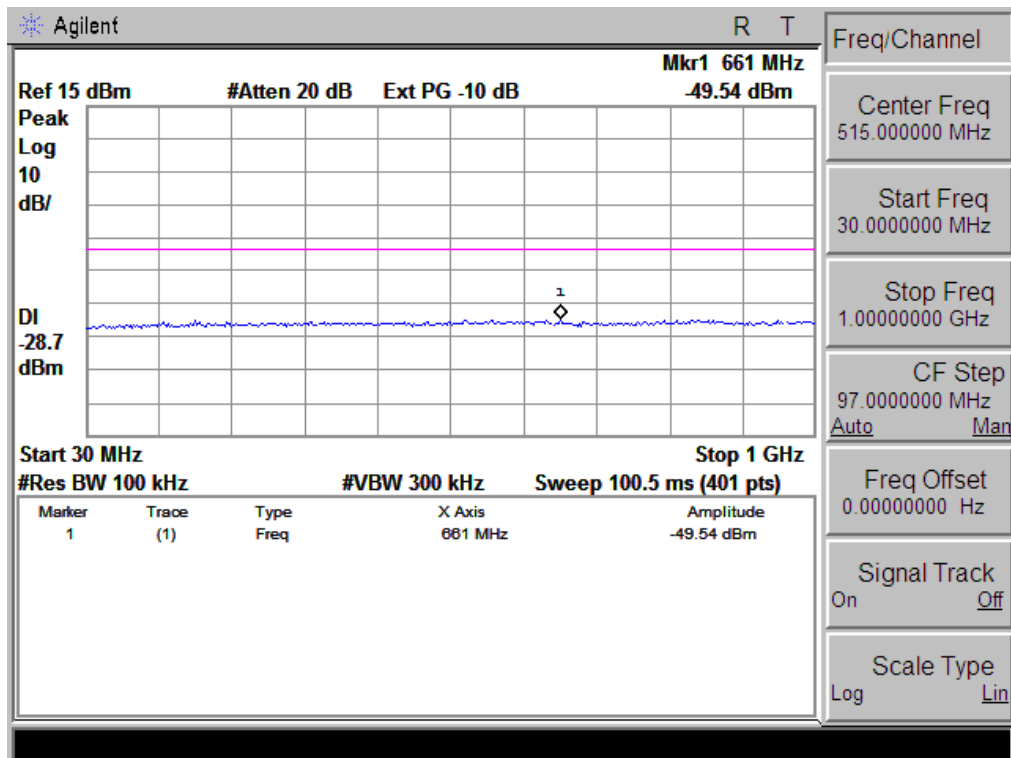

### 802.11n-HT40 High Channel

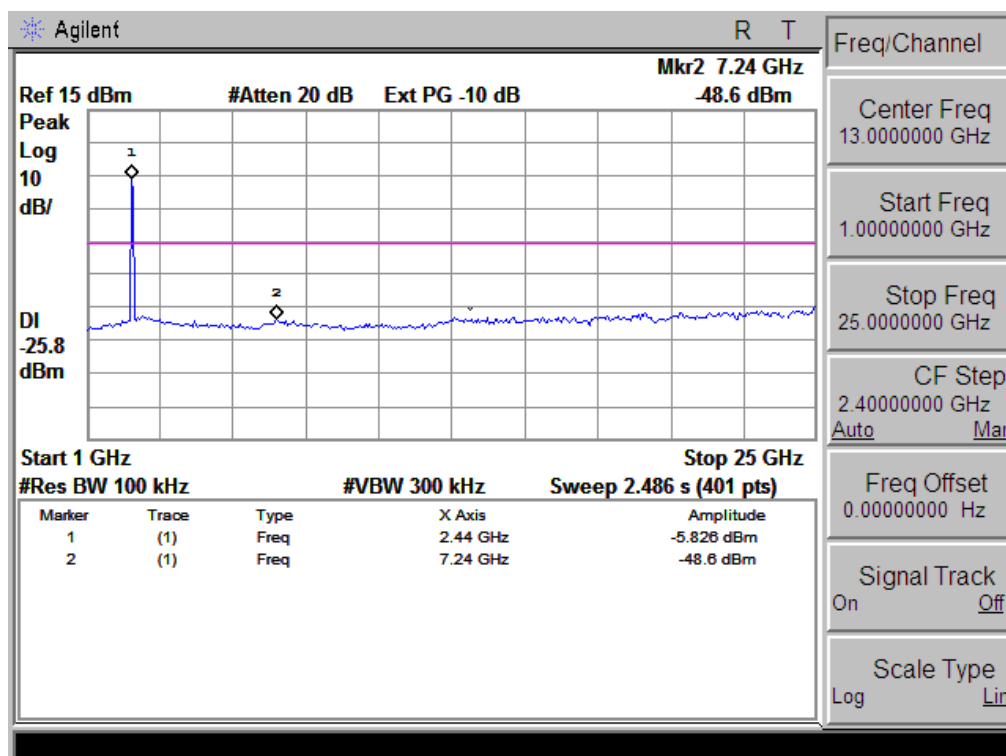
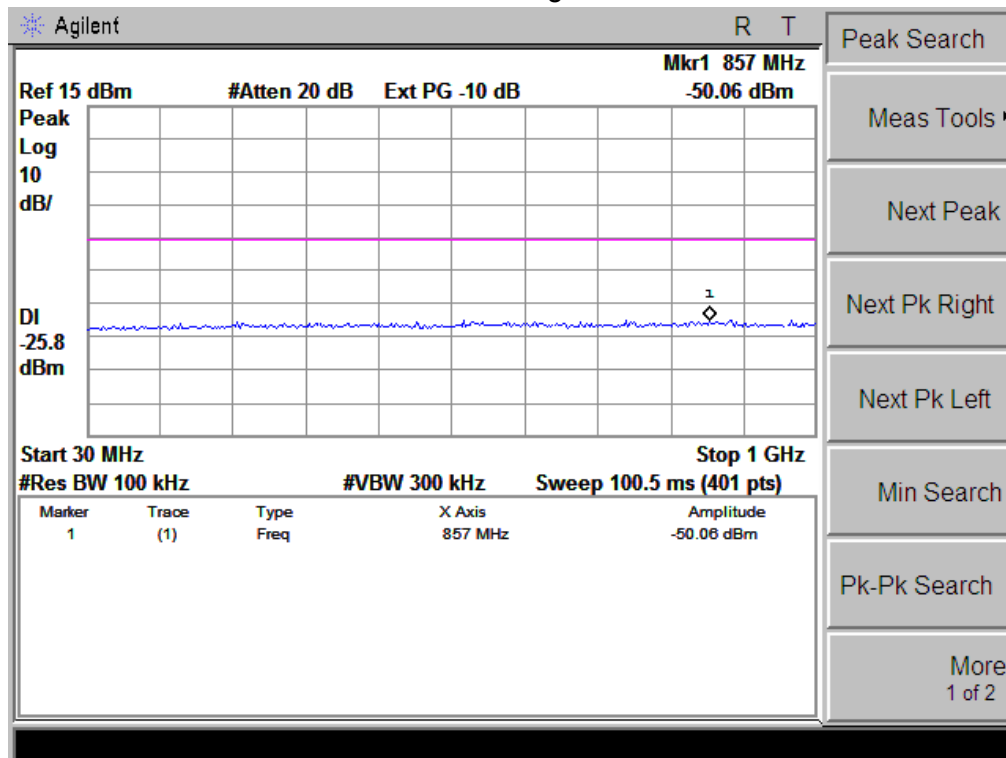

#### 4. POWER SPECTRAL DENSITY TEST

##### 4.1 APPLIED PROCEDURES / LIMIT

FCC Part15 (15.247) , Subpart C				
Section	Test Item	Limit	Frequency Range (MHz)	Result
15.247	Power Spectral Density	8 dBm (in any 3KHz)	2400-2483.5	PASS

##### 4.1.1 TEST PROCEDURE

1. Set analyzer center frequency to DTS channel center frequency.
2. Set the span to 1.5 times the DTS channel bandwidth.
3. Set the RBW  $\geq$  3 kHz.
4. Set the VBW  $\geq$  3 x RBW.
5. Detector = peak.
6. Sweep time = auto couple.
7. Trace mode = max hold.
8. Allow trace to fully stabilize.
9. Use the peak marker function to determine the maximum amplitude level.
10. If measured value exceeds limit, reduce RBW (no less than 3 kHz) and repeat.

##### 4.1.2 DEVIATION FROM STANDARD

No deviation.

##### 4.1.3 TEST SETUP

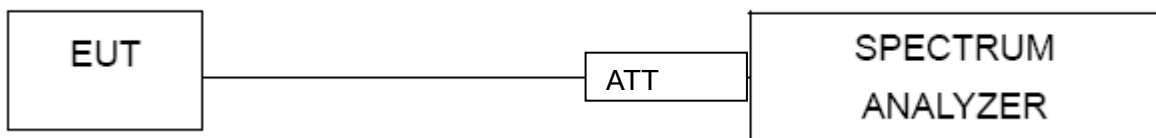

##### 4.1.4 EUT OPERATION CONDITIONS

The EUT tested system was configured as the statements of 2.1 Unless otherwise a special operating condition is specified in the follows during the testing.

### 4.1.5 TEST RESULTS

EUT :	Tablet PC	Model Name :	EGD103
Temperature :	25 °C	Relative Humidity :	60%
Pressure :	1015 hPa	Test Voltage :	DC 3.7V
Test Mode :	TX b Mode /CH01, CH06, CH11		

Frequency	Power Density (dBm)	Limit (dBm)	Result
2412 MHz	-8.922	8	PASS
2437 MHz	-9.049	8	PASS
2462 MHz	-9.118	8	PASS

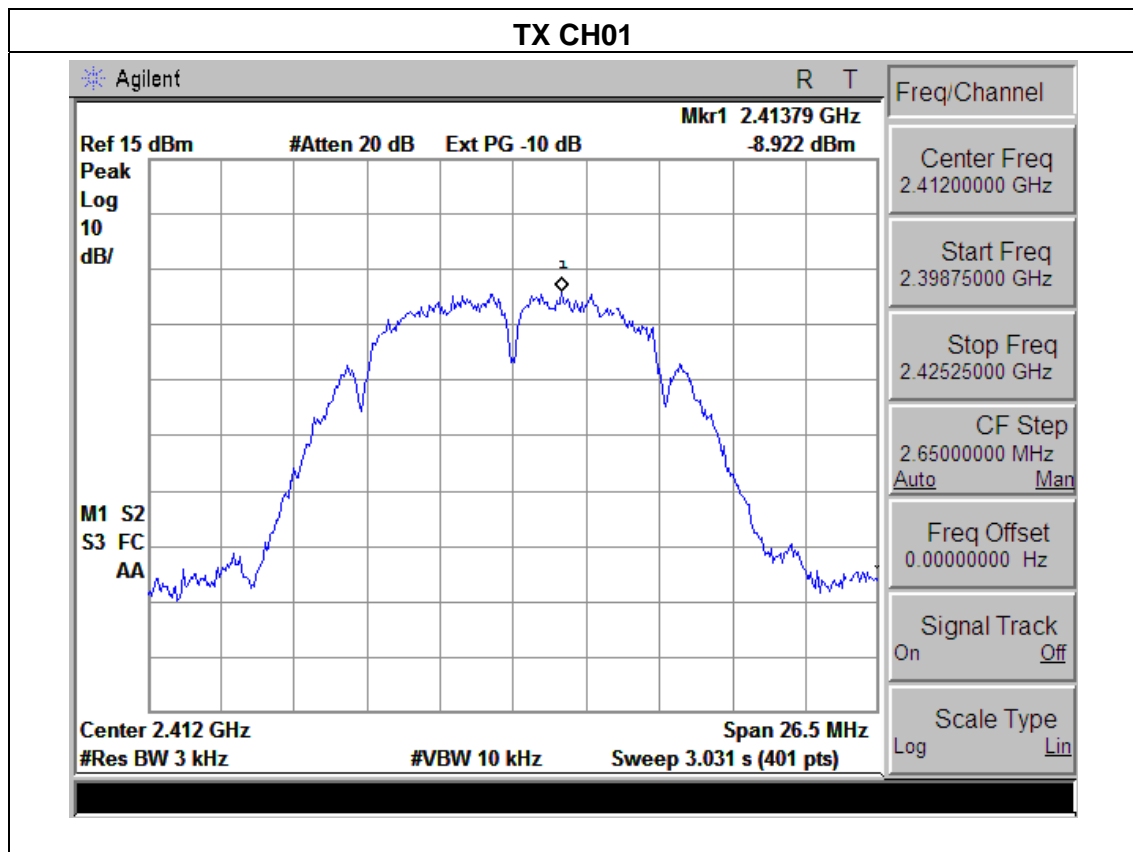

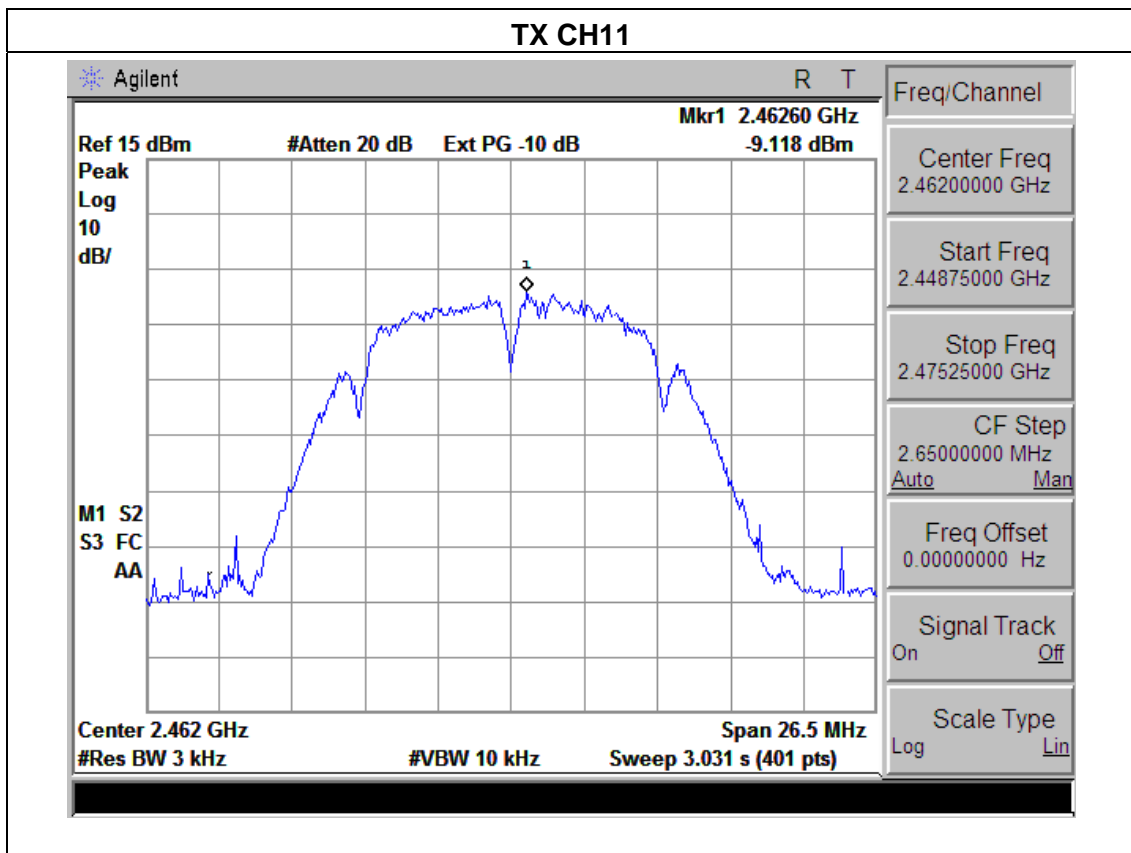
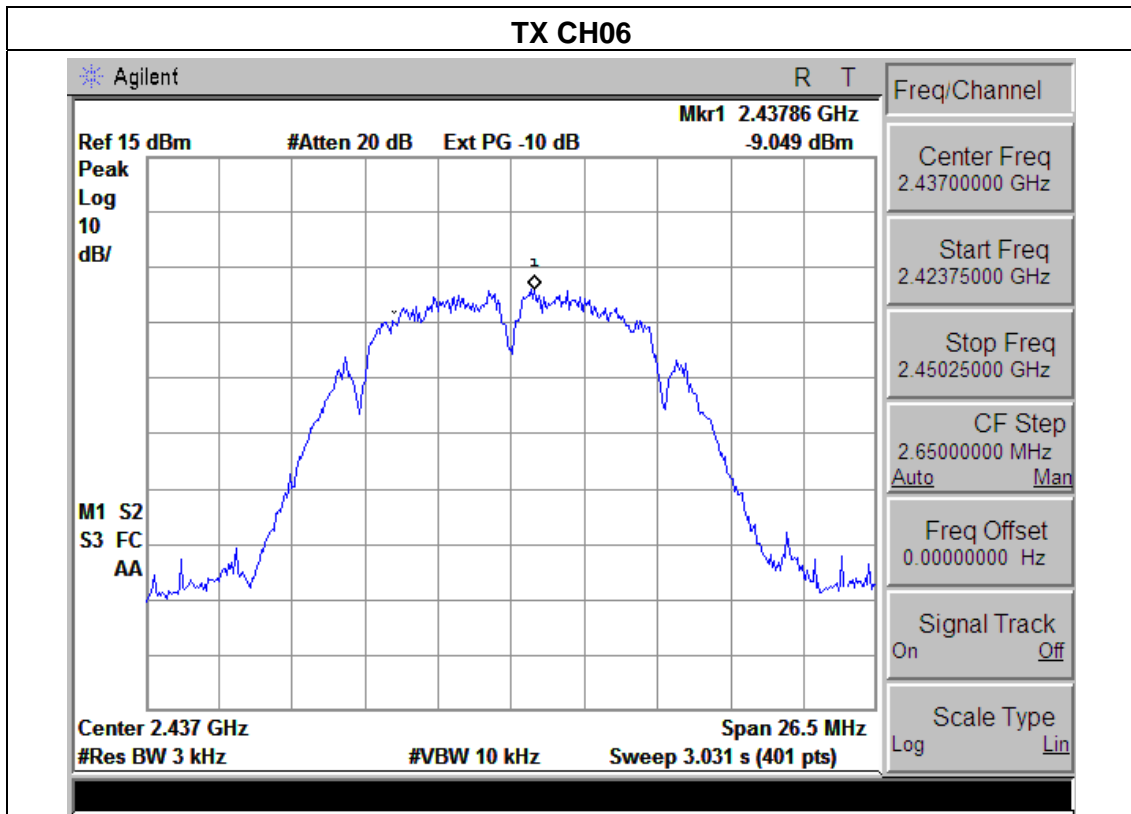

EUT :	Tablet PC	Model Name :	EGD103
Temperature :	25 °C	Relative Humidity :	60%
Pressure :	1015 hPa	Test Voltage :	DC 3.7V
Test Mode :	TX g Mode /CH01, CH06, CH11		

Frequency	Power Density (dBm)	Limit (dBm)	Result
2412 MHz	-13.65	8	PASS
2437 MHz	-11.95	8	PASS
2462 MHz	-14.47	8	PASS

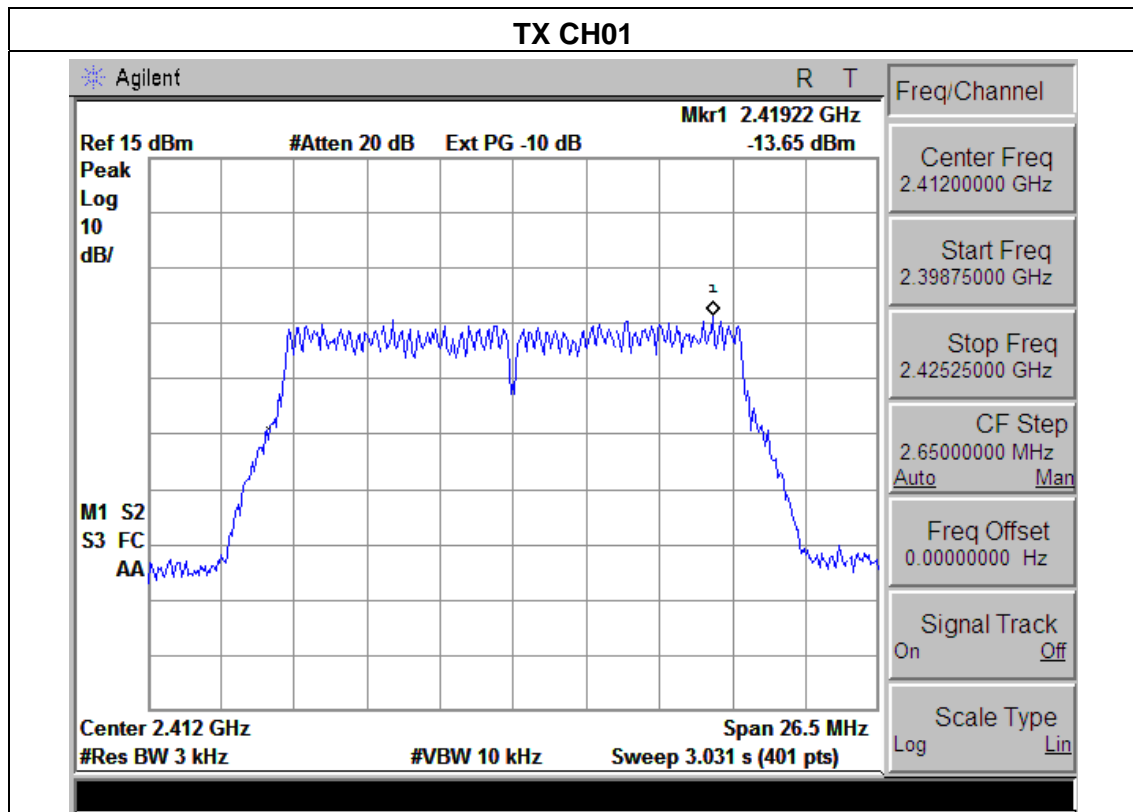

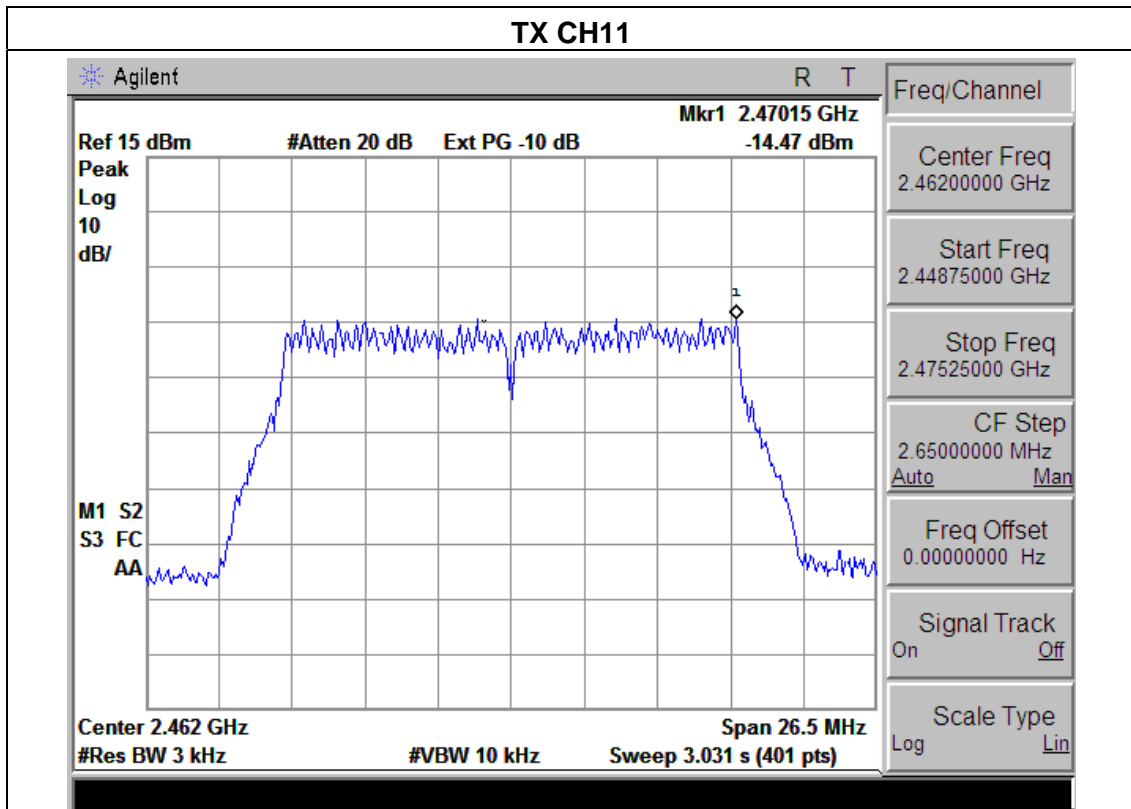
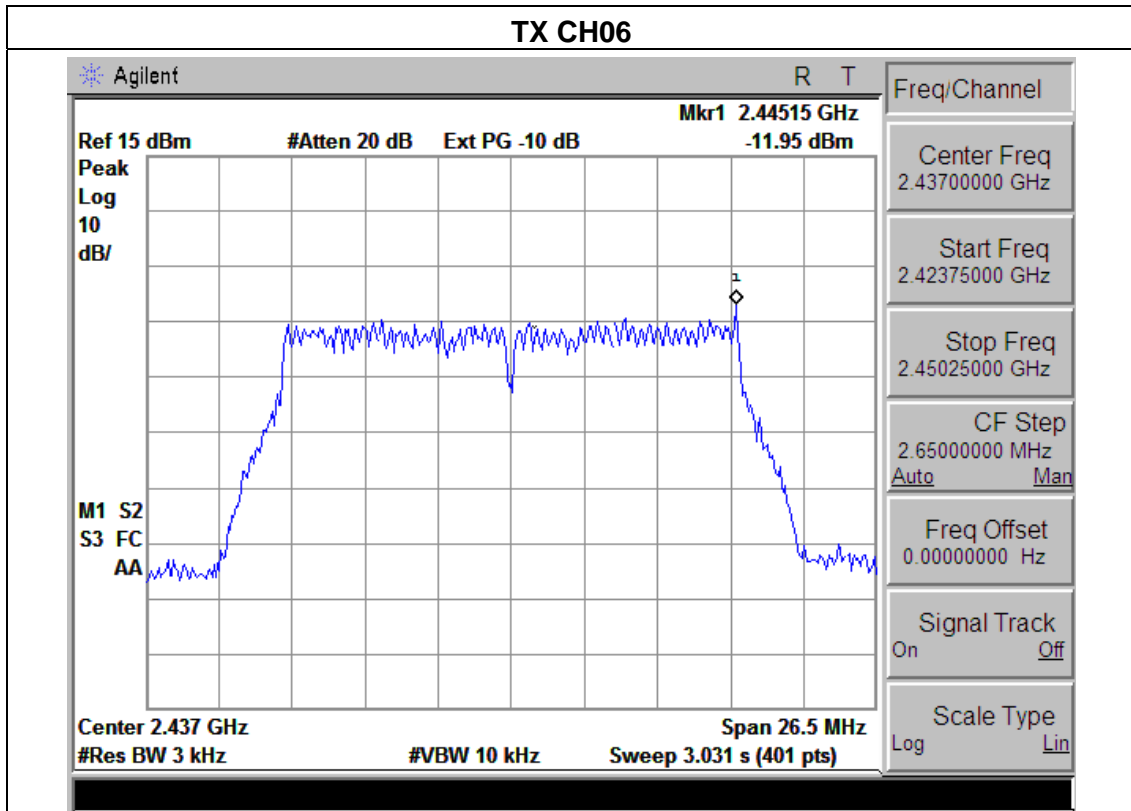



EUT :	Tablet PC	Model Name :	EGD103
Temperature :	25 °C	Relative Humidity :	60%
Pressure :	1015 hPa	Test Voltage :	DC 3.7V
Test Mode :	TX n Mode(20M) /CH01, CH06, CH11		

Frequency	Power Density (dBm)	Limit (dBm)	Result
2412 MHz	-15.84	8	PASS
2437 MHz	-15.65	8	PASS
2462 MHz	-16.05	8	PASS

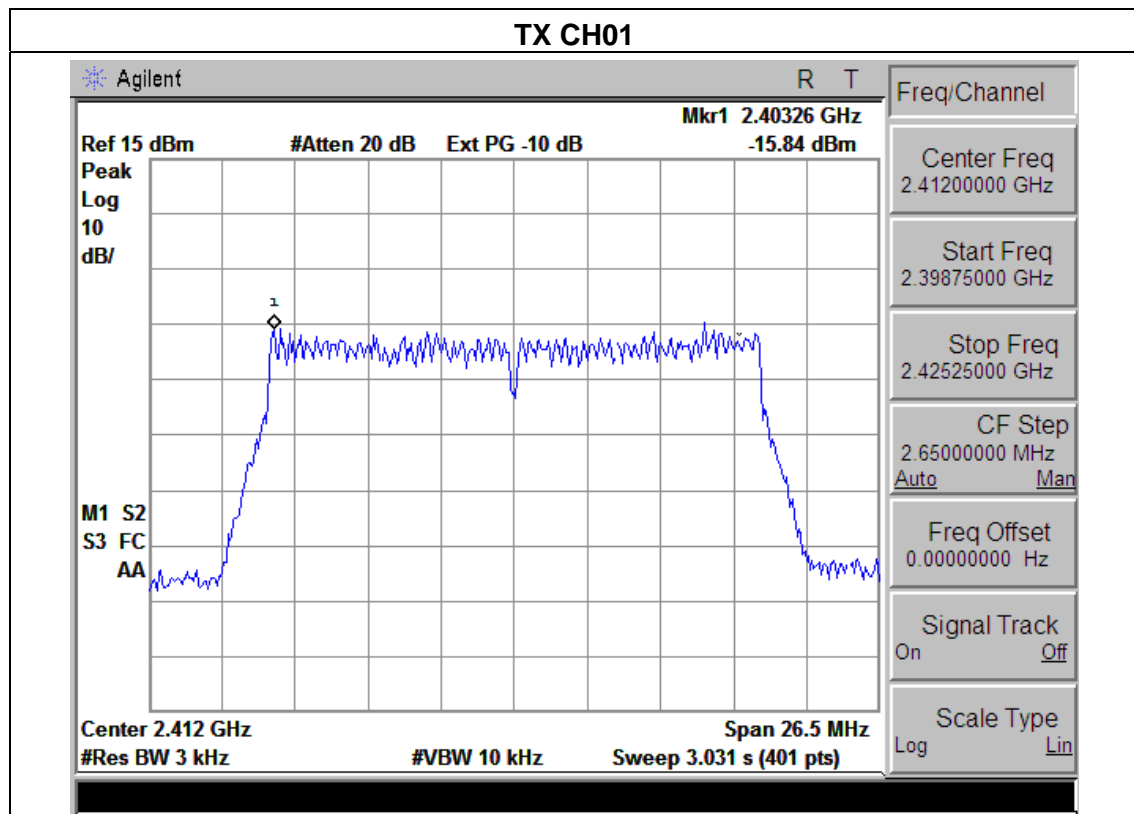

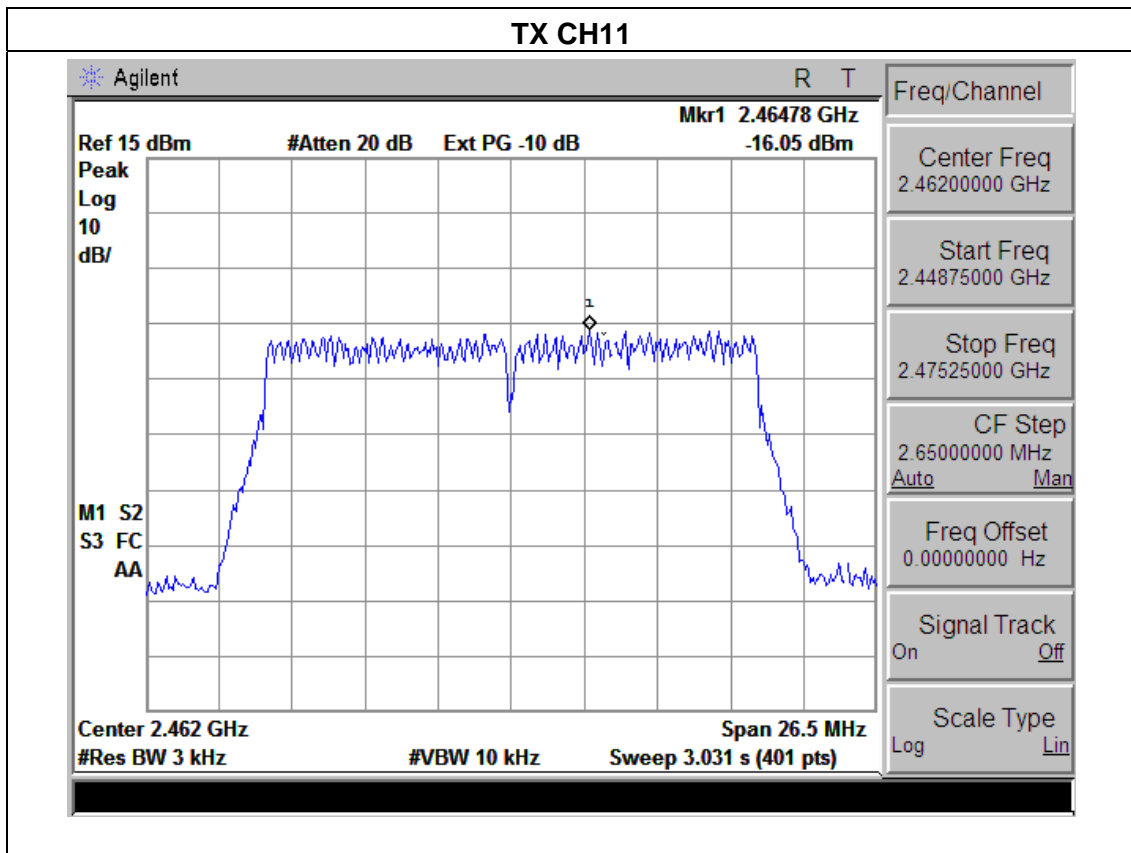
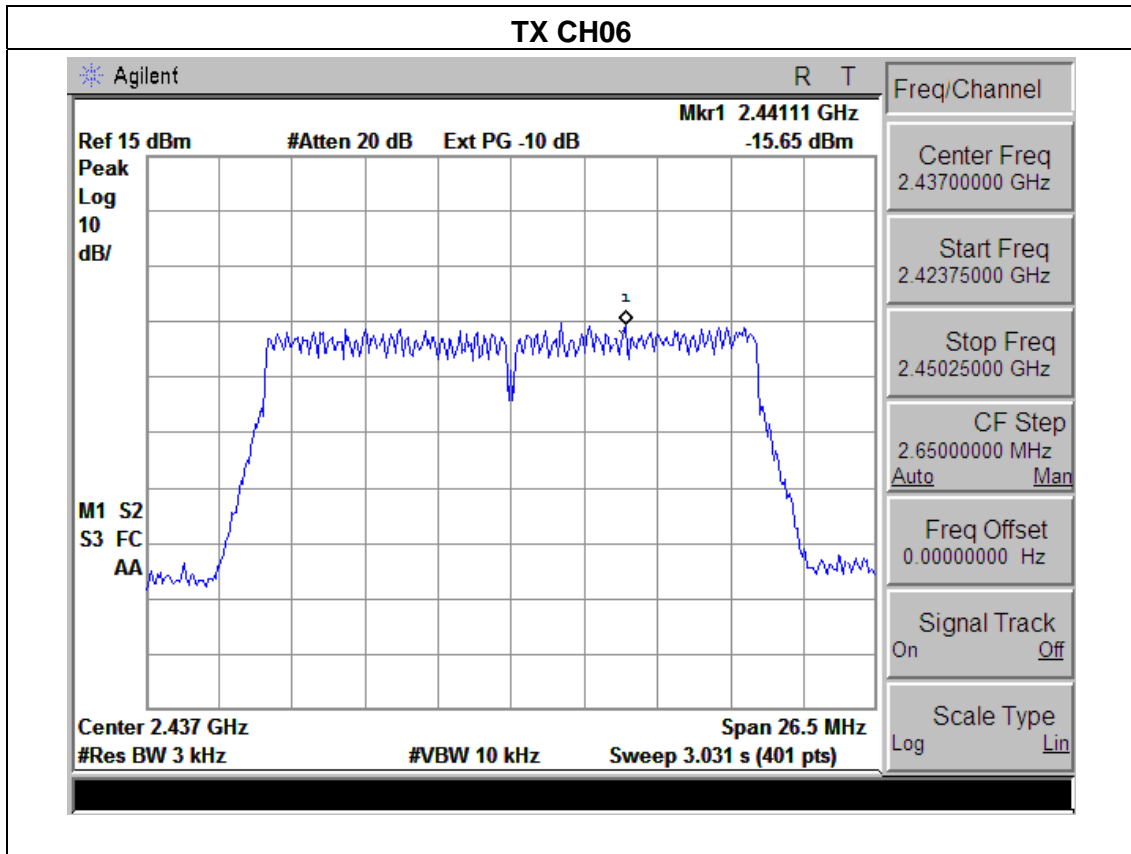

EUT :	Tablet PC	Model Name :	EGD103
Temperature :	25 °C	Relative Humidity :	60%
Pressure :	1015 hPa	Test Voltage :	DC 3.7V
Test Mode :	TX n Mode(40M) /CH03, CH06, CH09		

Frequency	Power Density (dBm)	Limit (dBm)	Result
2422 MHz	-20.15	8	PASS
2437 MHz	-19.62	8	PASS
2452 MHz	-20.34	8	PASS

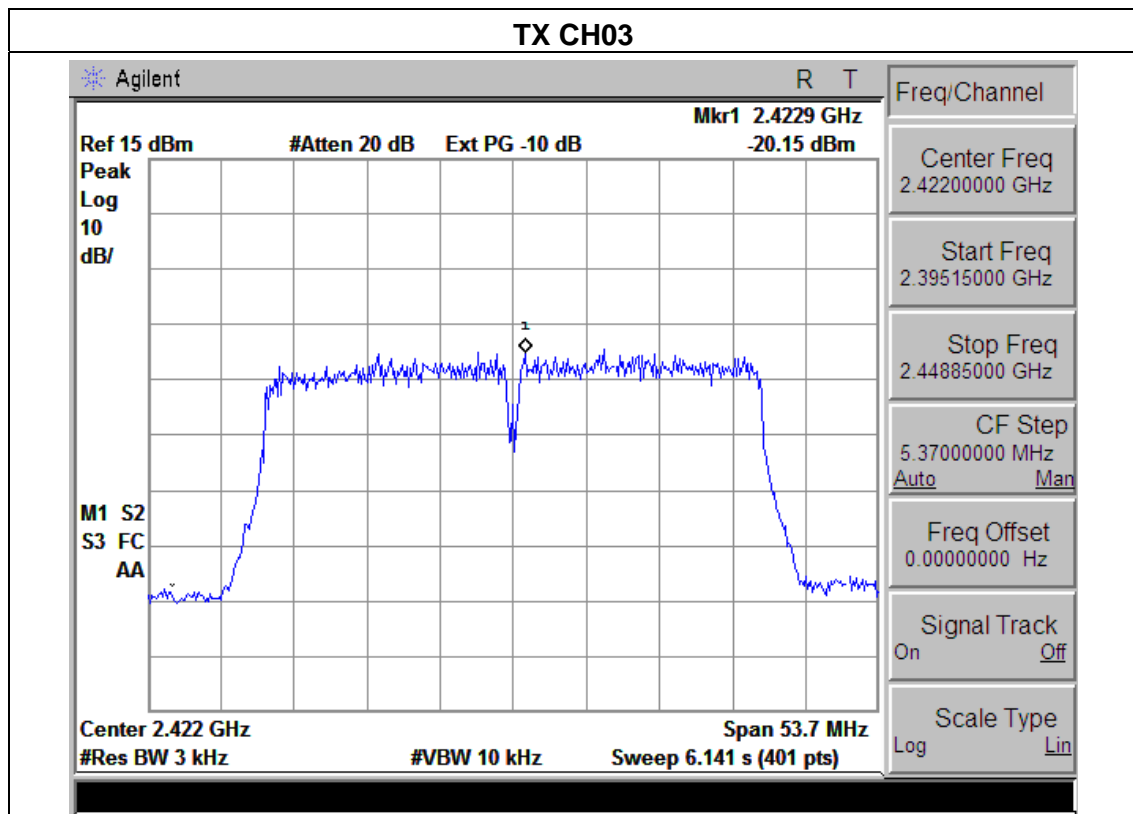

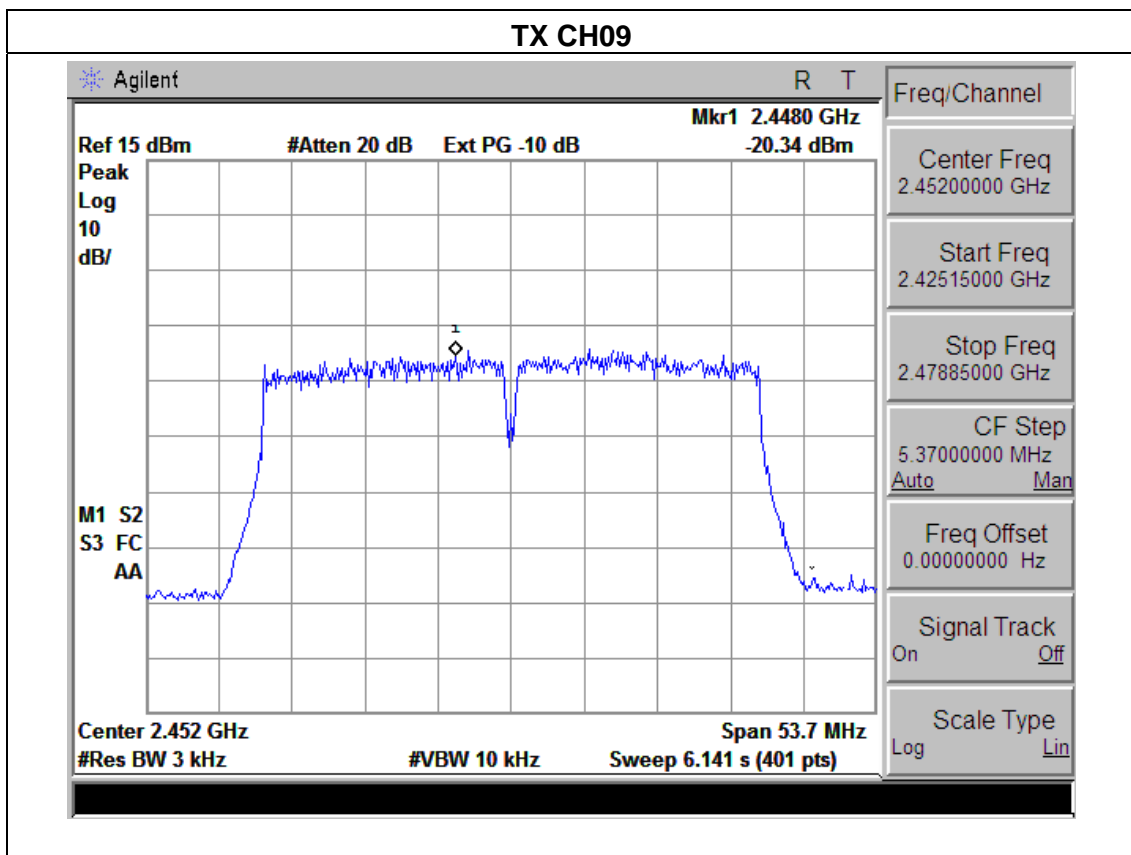
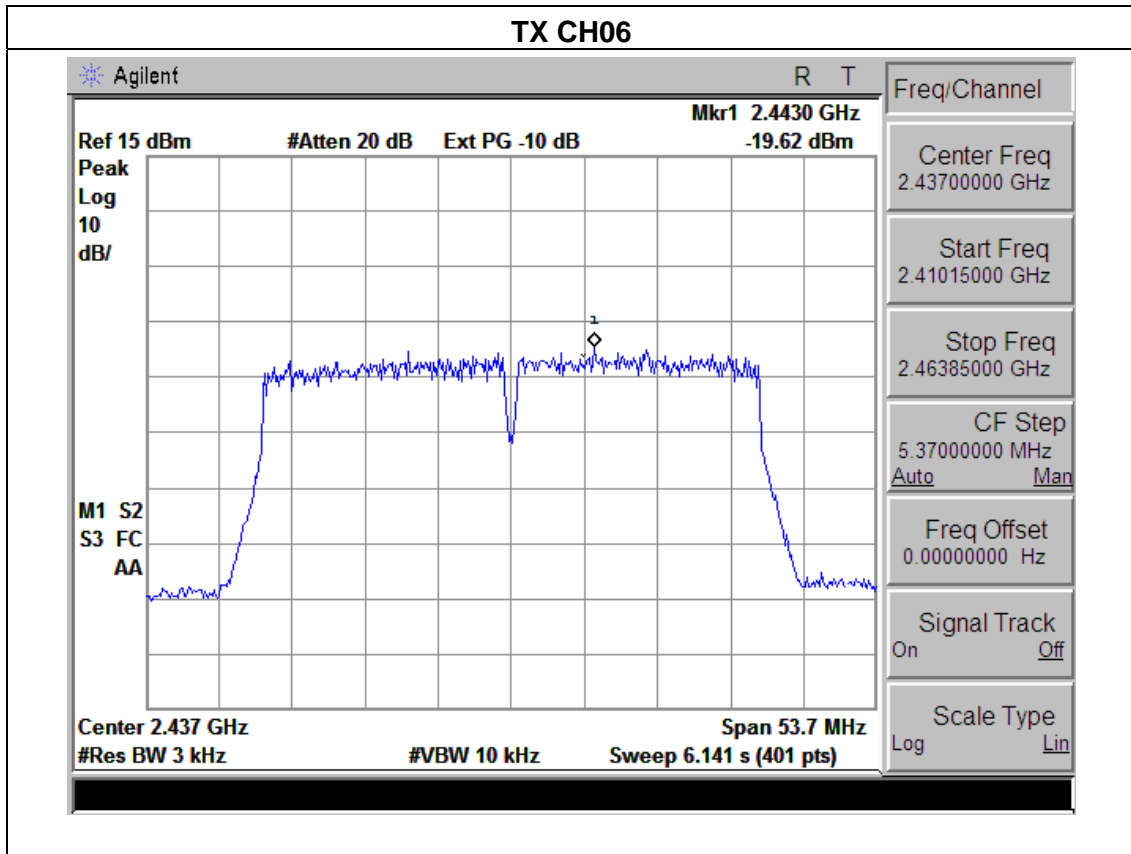

## 5. BANDWIDTH TEST

### 5.1 APPLIED PROCEDURES / LIMIT

FCC Part15 (15.247) , Subpart C				
Section	Test Item	Limit	Frequency Range (MHz)	Result
15.247(a)(2)	Bandwidth	$\geq 500\text{KHz}$ (6dB bandwidth)	2400-2483.5	PASS

#### 5.1.1 TEST PROCEDURE

According to KDB 558074 D01 DTS Meas Guidance v03r01

1. Check the calibration of the measuring instrument using either an internal calibrator or a known signal from an external generator
2. Position the EUT without connection to measurement instrument. Turn on the EUT and connect it to measurement instrument. Then set it to any one convenient frequency within its operating range. Set a reference level on the measuring instrument equal to the highest peak value.
3. Measure the frequency difference of two frequencies that were attenuated 6 dB from the reference level. Record the frequency difference as the emission bandwidth.
4. Repeat above procedures until all frequencies measured were complete.

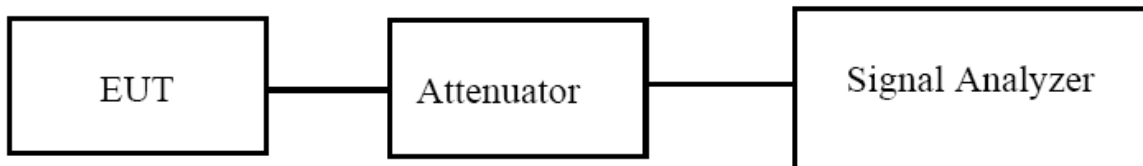

#### 5.1.2 TEST SETUP



#### 5.1.3 EUT OPERATION CONDITIONS

The EUT tested system was configured as the statements of 2.4 Unless otherwise a special operating condition is specified in the follows during the testing.



### TX CH 06

Agilent
R T

---

Ch Freq 2.437 GHz
Trig Free

---

Ref 15 dBm
#Atten 20 dB
Ext PG -10 dB

#Peak  
Log  
10  
dB/

Freq/Channel

Center Freq  
2.43700000 GHz

Start Freq  
2.42200000 GHz

Stop Freq  
2.45200000 GHz

CF Step  
3.00000000 MHz  
Auto Man

Freq Offset  
0.00000000 Hz

Signal Track  
On Off

Scale Type  
Log Lin

---

Center 2.437 GHz
Span 30 MHz

#Res BW 100 kHz
#VBW 300 kHz
Sweep 4 ms (401 pts)

<b>Occupied Bandwidth</b>	Occ BW % Pwr	99.00 %
<b>11.9018 MHz</b>	x dB	-6.00 dB
Transmit Freq Error	25.181 kHz	
x dB Bandwidth	9.065 MHz	

### TX CH 11

Agilent
R T

---

Ch Freq 2.462 GHz
Trig Free

---

Ref 15 dBm
#Atten 20 dB
Ext PG -10 dB

#Peak  
Log  
10  
dB/

Freq/Channel

Center Freq  
2.46200000 GHz

Start Freq  
2.44700000 GHz

Stop Freq  
2.47700000 GHz

CF Step  
3.00000000 MHz  
Auto Man

Freq Offset  
0.00000000 Hz

Signal Track  
On Off

Scale Type  
Log Lin

---

Center 2.462 GHz
Span 30 MHz

#Res BW 100 kHz
#VBW 300 kHz
Sweep 4 ms (401 pts)

<b>Occupied Bandwidth</b>	Occ BW % Pwr	99.00 %
<b>11.9145 MHz</b>	x dB	-6.00 dB
Transmit Freq Error	13.783 kHz	
x dB Bandwidth	8.121 MHz	

EUT :	Tablet PC	Model Name :	EGD103
Temperature :	25 °C	Relative Humidity :	60%
Pressure :	1012 hPa	Test Voltage :	DC 3.7V
Test Mode :	TX g Mode /CH01, CH06, CH11		

Channel	Frequency (MHz)	6dB bandwidth (MHz)	Limit (kHz)	Result
Low	2412	16.413	500	Pass
Middle	2437	16.516	500	Pass
High	2462	16.464	500	Pass

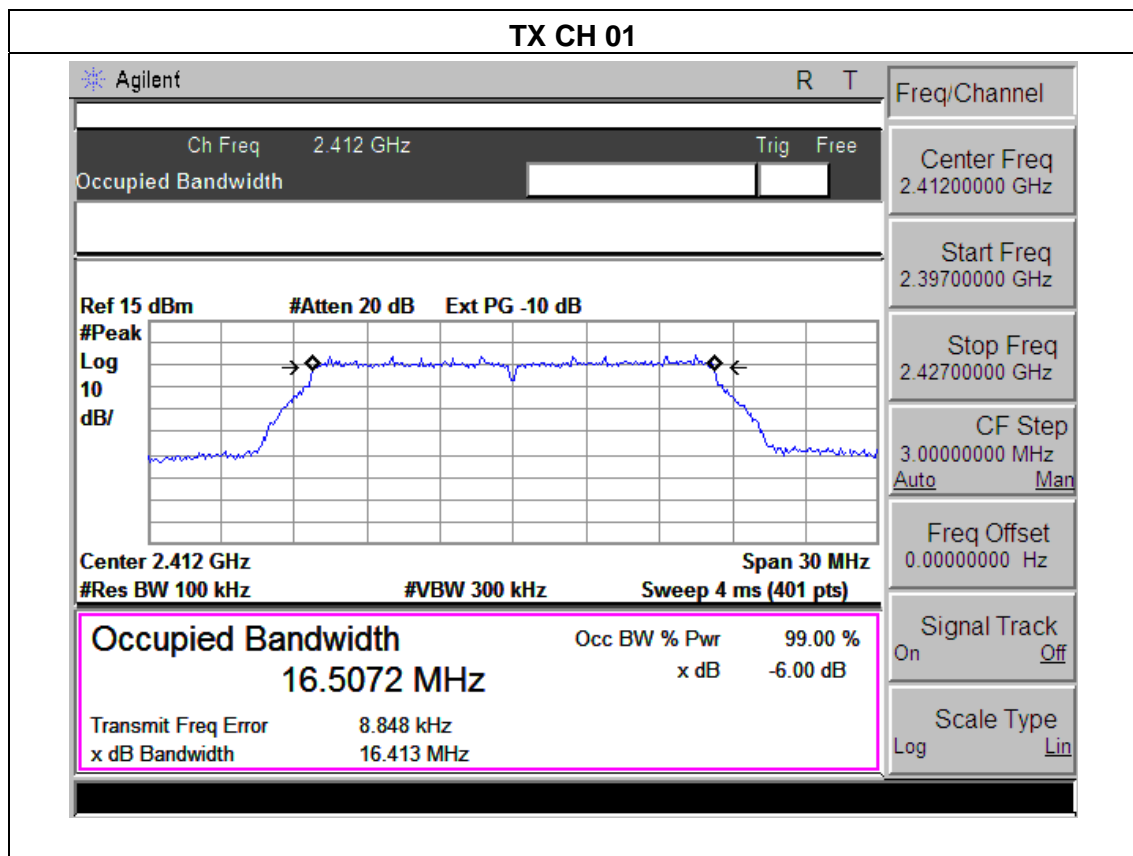



### TX CH 06

Agilent
R T

---

Ch Freq 2.437 GHz
Trig Free

---

Occupied Bandwidth

---

Ref 15 dBm
#Atten 20 dB
Ext PG -10 dB

#Peak  
Log  
10  
dB/

Freq/Channel

Center Freq  
2.43700000 GHz

Start Freq  
2.42200000 GHz

Stop Freq  
2.45200000 GHz

CF Step  
3.00000000 MHz  
Auto Man

Freq Offset  
0.00000000 Hz

Signal Track  
On Off

Scale Type  
Log Lin

---

Center 2.437 GHz
Span 30 MHz

#Res BW 100 kHz
#VBW 300 kHz
Sweep 4 ms (401 pts)

<b>Occupied Bandwidth</b>	Occ BW % Pwr	99.00 %
16.5514 MHz	x dB	-6.00 dB
Transmit Freq Error	17.529 kHz	
x dB Bandwidth	16.516 MHz	

### TX CH 11

Agilent
R T

---

Ch Freq 2.462 GHz
Trig Free

---

Occupied Bandwidth

---

Ref 15 dBm
#Atten 20 dB
Ext PG -10 dB

#Peak  
Log  
10  
dB/

Freq/Channel

Center Freq  
2.46200000 GHz

Start Freq  
2.44700000 GHz

Stop Freq  
2.47700000 GHz

CF Step  
3.00000000 MHz  
Auto Man

Freq Offset  
0.00000000 Hz

Signal Track  
On Off

Scale Type  
Log Lin

---

Center 2.462 GHz
Span 30 MHz

#Res BW 100 kHz
#VBW 300 kHz
Sweep 4 ms (401 pts)

<b>Occupied Bandwidth</b>	Occ BW % Pwr	99.00 %
16.5064 MHz	x dB	-6.00 dB
Transmit Freq Error	11.218 kHz	
x dB Bandwidth	16.464 MHz	

EUT :	Tablet PC	Model Name :	EGD103
Temperature :	25 °C	Relative Humidity :	60%
Pressure :	1012 hPa	Test Voltage :	DC 3.7V
Test Mode :	TX n Mode(20M) /CH01, CH06, CH11		

Channel	Frequency (MHz)	6dB bandwidth (MHz)	Limit (kHz)	Result
Low	2412	17.656	500	Pass
Middle	2437	17.625	500	Pass
High	2462	17.679	500	Pass

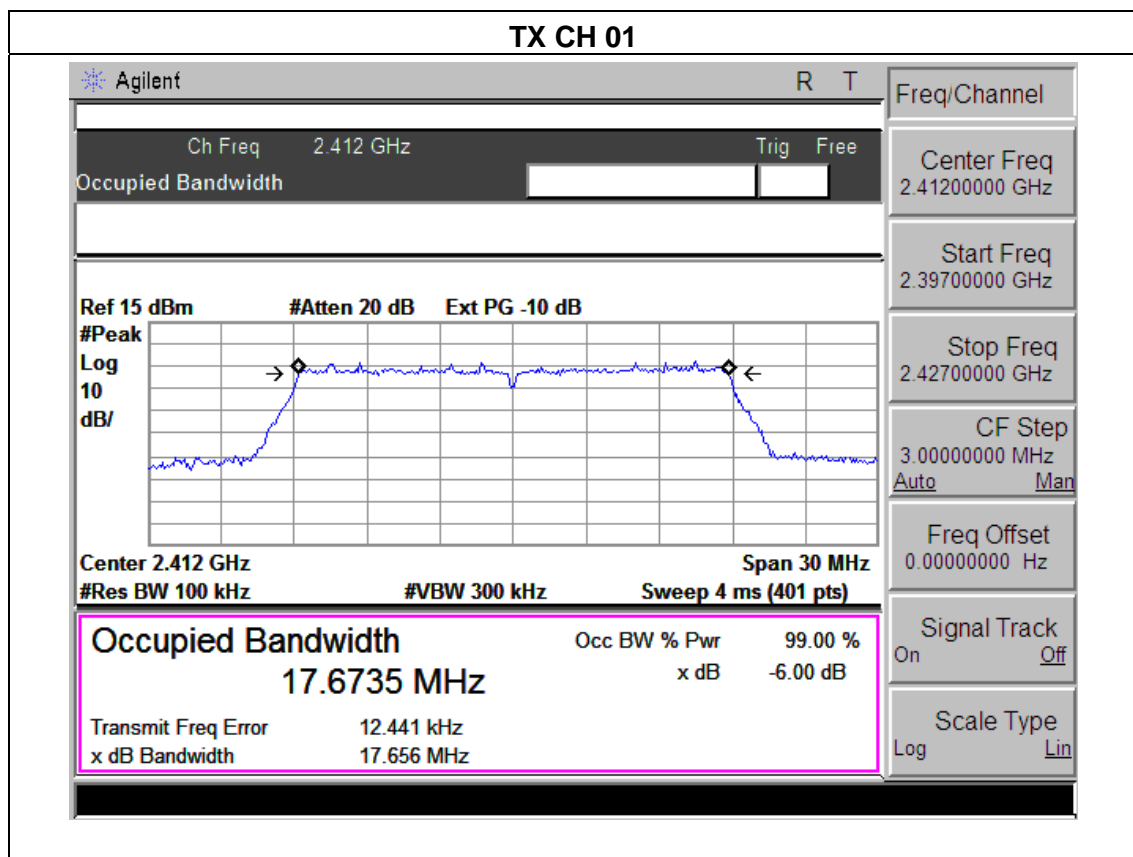

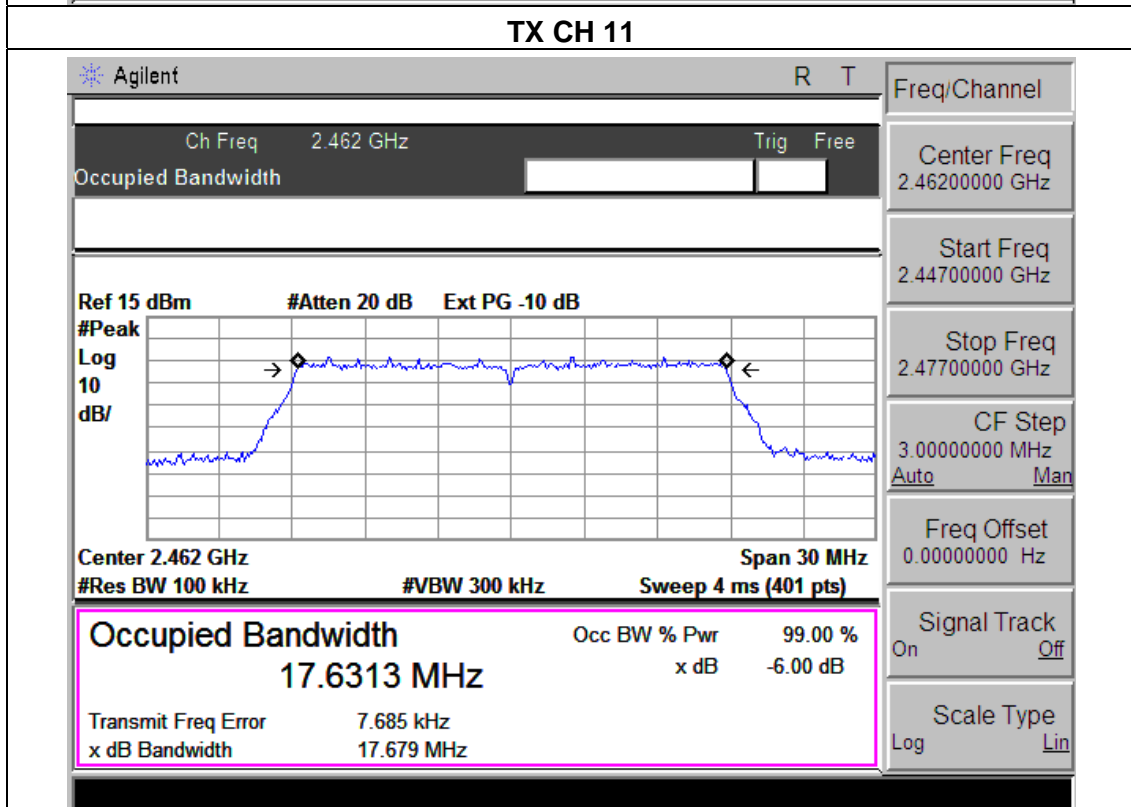
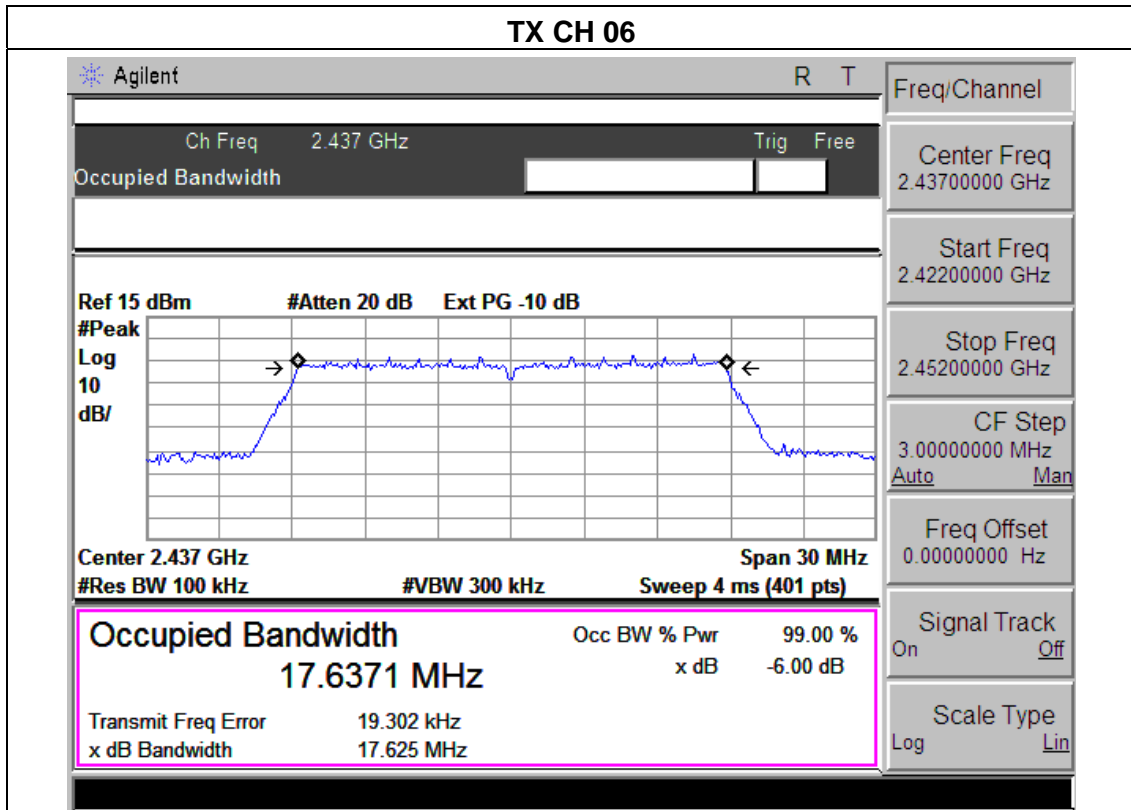

EUT :	Tablet PC	Model Name :	EGD103
Temperature :	25 °C	Relative Humidity :	60%
Pressure :	1012 hPa	Test Voltage :	DC 3.7V
Test Mode :	TX n Mode(40M) /CH03, CH06, CH09		

Channel	Frequency (MHz)	6dB bandwidth (MHz)	Limit (kHz)	Result
Low	2422	35.569	500	Pass
Middle	2437	35.535	500	Pass
High	2452	35.566	500	Pass

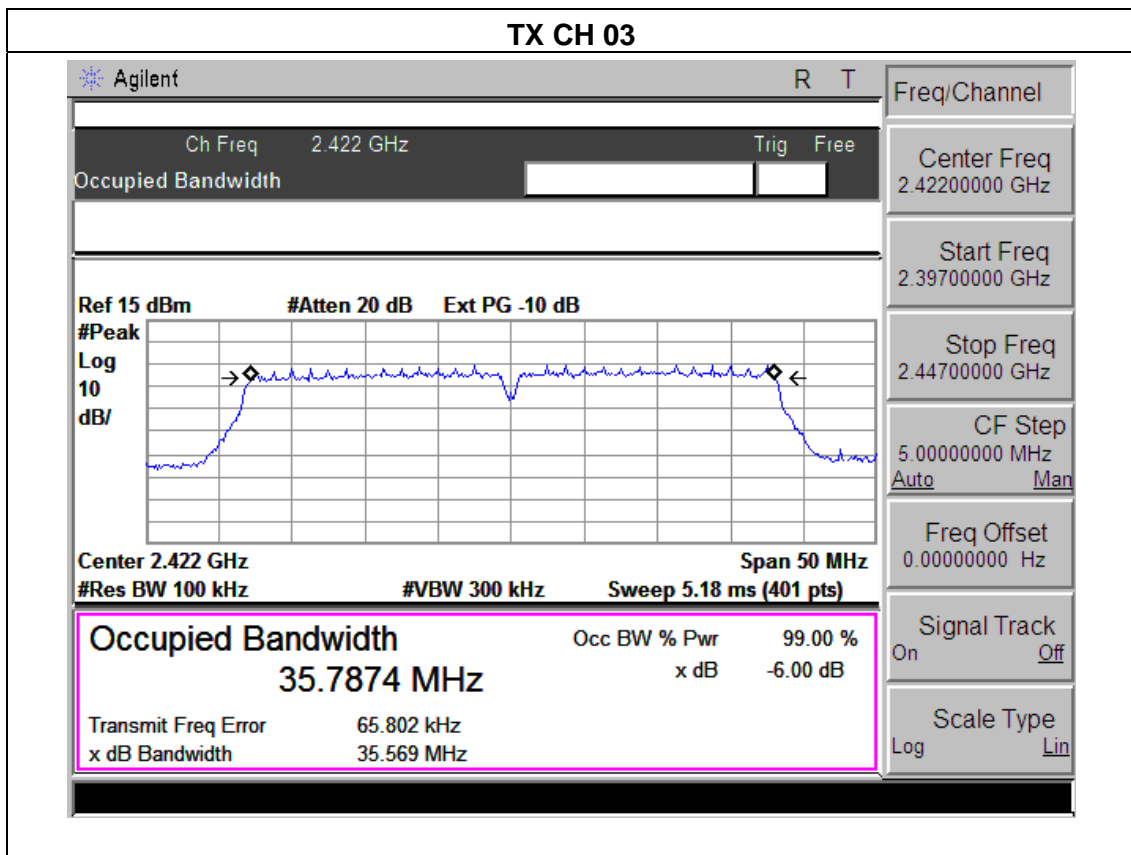

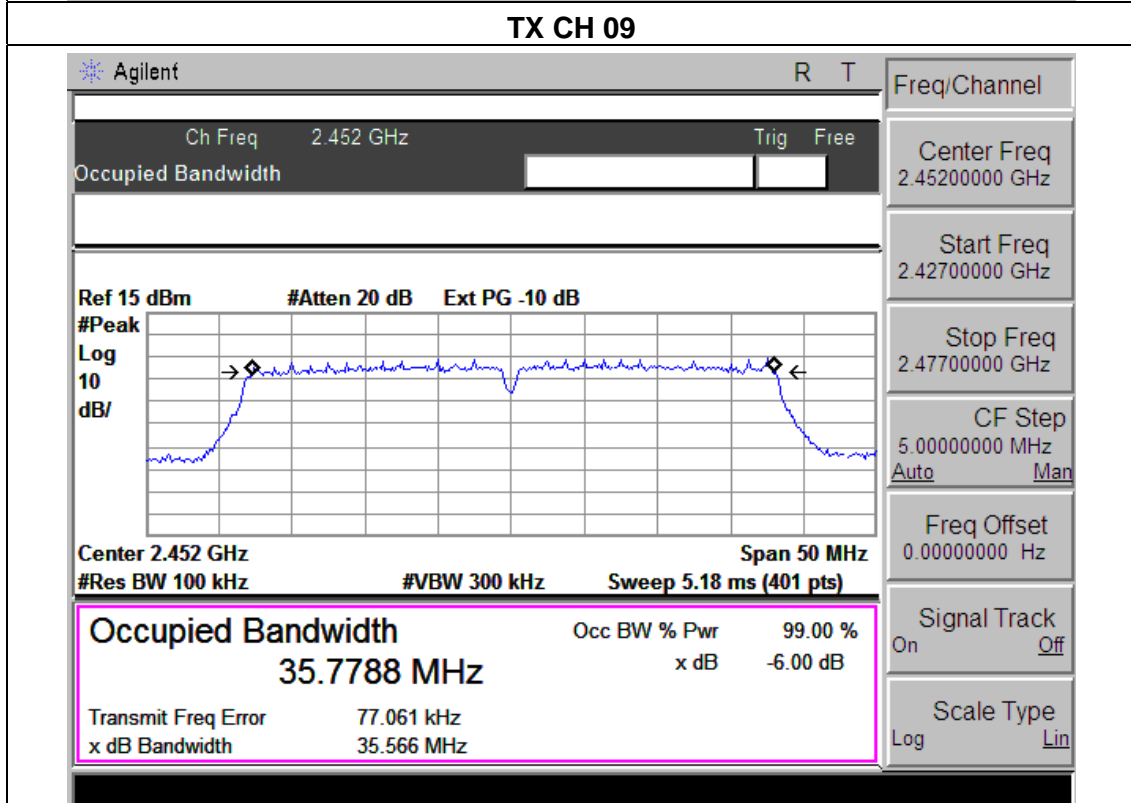
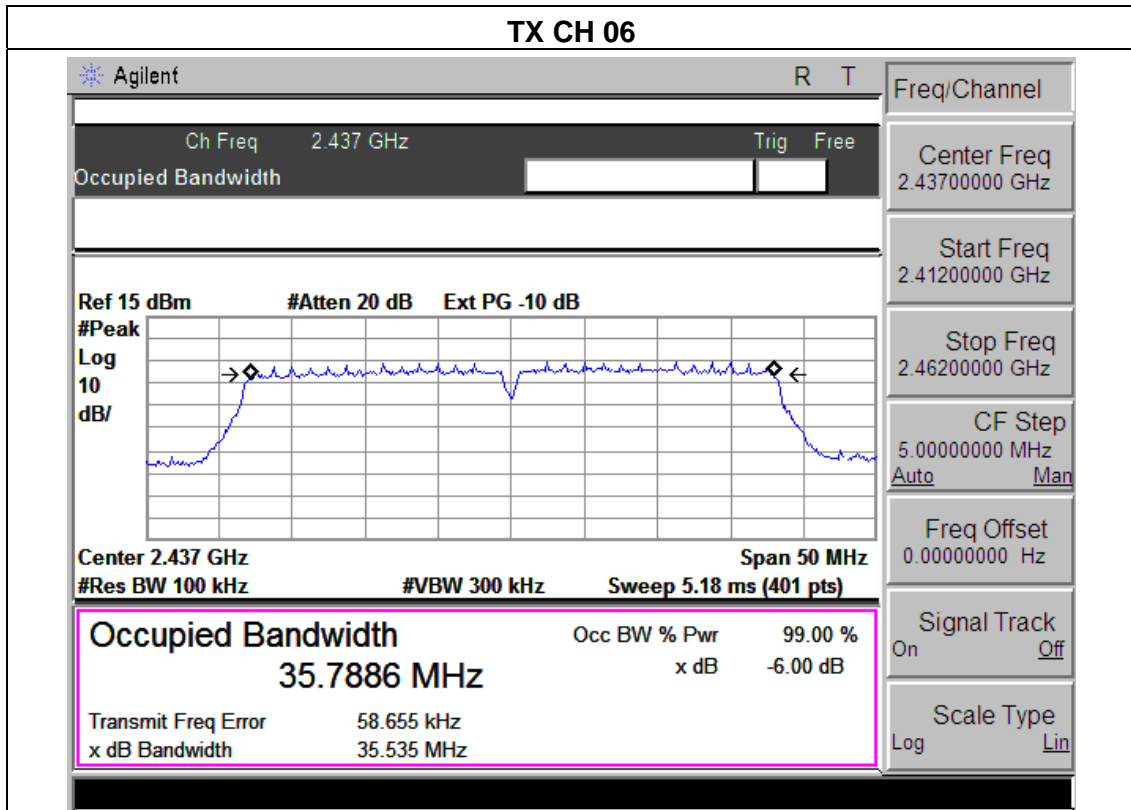

**6. PEAK OUTPUT POWER TEST**

**6.1 APPLIED PROCEDURES / LIMIT**

FCC Part15 (15.247) , Subpart C				
Section	Test Item	Limit	Frequency Range (MHz)	Result
15.247(b)(3)	Peak Output Power	1 watt or 30dBm	2400-2483.5	PASS

**6.1.1 TEST PROCEDURE**

- a. The EUT was directly connected to the Power meter

**6.1.2 DEVIATION FROM STANDARD**

No deviation.

**6.1.3 TEST SETUP**



**6.1.4 EUT OPERATION CONDITIONS**

The EUT tested system was configured as the statements of 2.4 Unless otherwise a special operating condition is specified in the follows during the testing.

**6.1.5 TEST RESULTS**

EUT :	Tablet PC	Model Name :	EGD103
Temperature :	25 °C	Relative Humidity :	60%
Pressure :	1012 hPa	Test Voltage :	DC 3.7V
Test Mode :	TX b/g/n(20M, 40M) Mode /CH01, CH06, CH11		

<b>TX 802.11b Mode</b>				
Test Channe	Frequency	Maximum Conducted Output Power(PK)	Maximum Conducted Output Power(AV)	LIMIT
	(MHz)	(dBm)		dBm
CH01	2412	12.56	9.16	30
CH06	2437	12.67	9.21	30
CH11	2462	12.54	9.15	30
<b>TX 802.11g Mode</b>				
CH01	2412	10.49	7.36	30
CH06	2437	10.57	7.41	30
CH11	2462	10.58	7.43	30
<b>TX 802.11n(20M) Mode</b>				
CH01	2412	10.37	7.28	30
CH06	2437	10.42	7.31	30
CH11	2462	10.46	7.37	30
<b>TX 802.11n(40M) Mode</b>				
CH03	2422	8.37	5.28	30
CH06	2437	8.42	5.31	30
CH09	2452	8.46	5.37	30

**7. 100 KHZ BANDWIDTH OF FREQUENCY BAND EDGE**

**APPLICABLE STANDARD**

In any 100 kHz bandwidth outside the frequency band in which the spread Tablet PC or digitally modulated intentional radiator is operating, the radio frequency power that is produced by the intentional radiator shall be at least 20 dB below that in the 100 kHz bandwidth within the band that contains the highest level of the desired power, based on either an RF conducted or a radiated measurement, provided the transmitter demonstrates compliance with the peak conducted power limits. If the transmitter complies with the conducted power limits based on the use of RMS averaging over a time interval, as permitted under paragraph (b)(3) of this section, the attenuation required under this paragraph shall be 30 dB instead of 20 dB. Attenuation below the general limits specified in §15.209(a) is not required. In addition, radiated emissions which fall in the restricted bands, as defined in §15.205(a), must also comply with the radiated emission limits specified in §15.209(a) (see §15.205(c)).

**TEST PROCEDURE**

- a) Check the calibration of the measuring instrument using either an internal calibrator or a known signal from an external generator.
- b) Position the EUT without connection to measurement instrument. Turn on the EUT and connect its antenna terminal to measurement instrument via a low loss cable. Then set it to any one measured frequency within its operating range, and make sure the instrument is operated in its linear range.
- c) Set RBW to 100 kHz and VBW of Tablet PC analyzer to 300 kHz with a convenient frequency span including 100 kHz bandwidth from band edge.
- d) Measure the highest amplitude appearing on spectral display and set it as a reference level. Plot the graph with marking the highest point and edge frequency.
- e) Repeat above procedures until all measured frequencies were complete.

**7.1 DEVIATION FROM STANDARD**

No deviation.

**7.2 TEST SETUP**

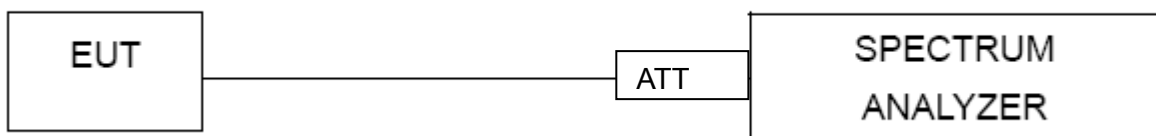

**7.3 EUT OPERATION CONDITIONS**

The EUT tested system was configured as the statements of 2.4 Unless otherwise a special operating condition is specified in the follows during the testing.



### 7.4 TEST RESULTS

EUT :	Tablet PC	Model Name :	EGD103
Temperature :	25 °C	Relative Humidity :	60%
Pressure :	1012 hPa	Test Voltage :	DC 3.7V

Frequency Band	Delta Peak to band emission (dBc)	> Limit (dBc)	Result
802.11b mode			
Left-band	45.57	20	Pass
Right-band	48.01	20	Pass
802.11g mode			
Left-band	43.04	20	Pass
Right-band	48.63	20	Pass
802.11n(20M) mode			
Left-band	41.36	20	Pass
Right-band	45.52	20	Pass
802.11n(40M) mode			
Left-band	40.90	20	Pass
Right-band	41.09	20	Pass

Frequency (MHz)	Meter Reading (dBµV)	Factor (dB)	Emission Level (dBµV/m)	Limits (dBµV/m)	Margin (dB)	Detector Type	Comment
<b>802.11b</b>							
2390	65.64	-13.06	52.58	74	-21.42	peak	Vertical
2390	66.93	-13.06	53.87	74	-20.13	peak	Horizontal
2483.5	66.56	-12.78	53.78	74	-20.22	peak	Vertical
2483.5	67.36	-12.78	54.58	74	-19.42	peak	Horizontal
<b>802.11g</b>							
2390	66.87	-13.06	53.81	74	-20.19	peak	Vertical
2390	66.54	-13.06	53.48	74	-20.52	peak	Horizontal
2483.5	65.35	-12.78	52.57	74	-21.43	peak	Vertical
2483.5	65.11	-12.78	52.33	74	-21.67	peak	Horizontal
<b>802.11n(20M)</b>							
2390	65.72	-13.06	52.66	74	-21.34	peak	Vertical
2390	66.82	-13.06	53.76	74	-20.24	peak	Horizontal
2483.5	64.03	-12.78	51.25	74	-22.75	peak	Vertical
2483.5	65.56	-12.78	52.78	74	-21.22	peak	Horizontal
<b>802.11n(40M)</b>							
2390	66.11	-13.06	53.05	74	-20.95	peak	Vertical
2390	66.05	-13.06	52.99	74	-21.01	peak	Horizontal
2483.5	67.29	-12.78	54.51	74	-19.49	peak	Vertical
2483.5	65.52	-12.78	52.74	74	-21.26	peak	Horizontal

Note: Refer to chapter 3.2 test method.

PK value is lower than the Average value limit, So average didn't record.

### 802.11b: Band Edge, Left Side

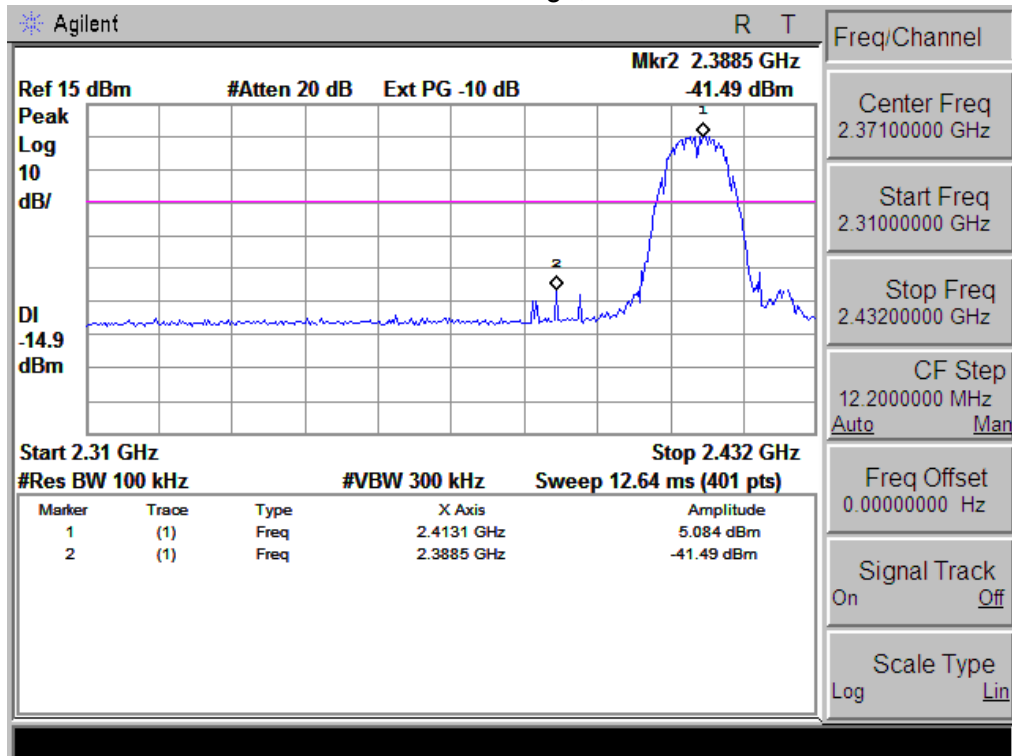

### 802.11b: Band Edge, Right Side

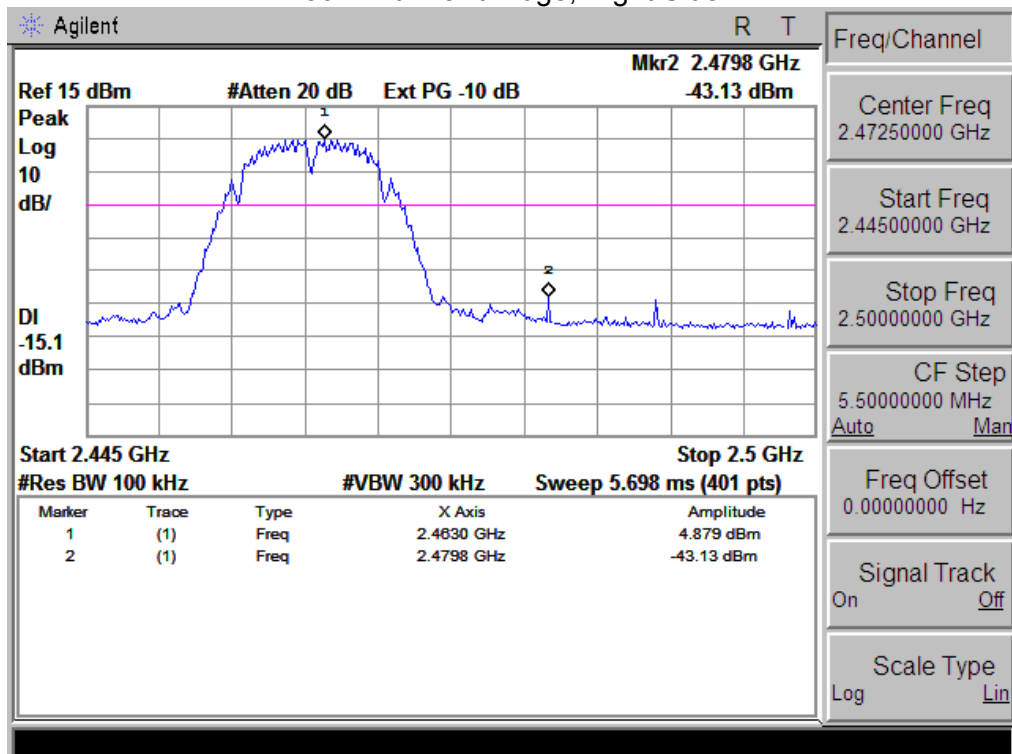

### 802.11g: Band Edge, Left Side

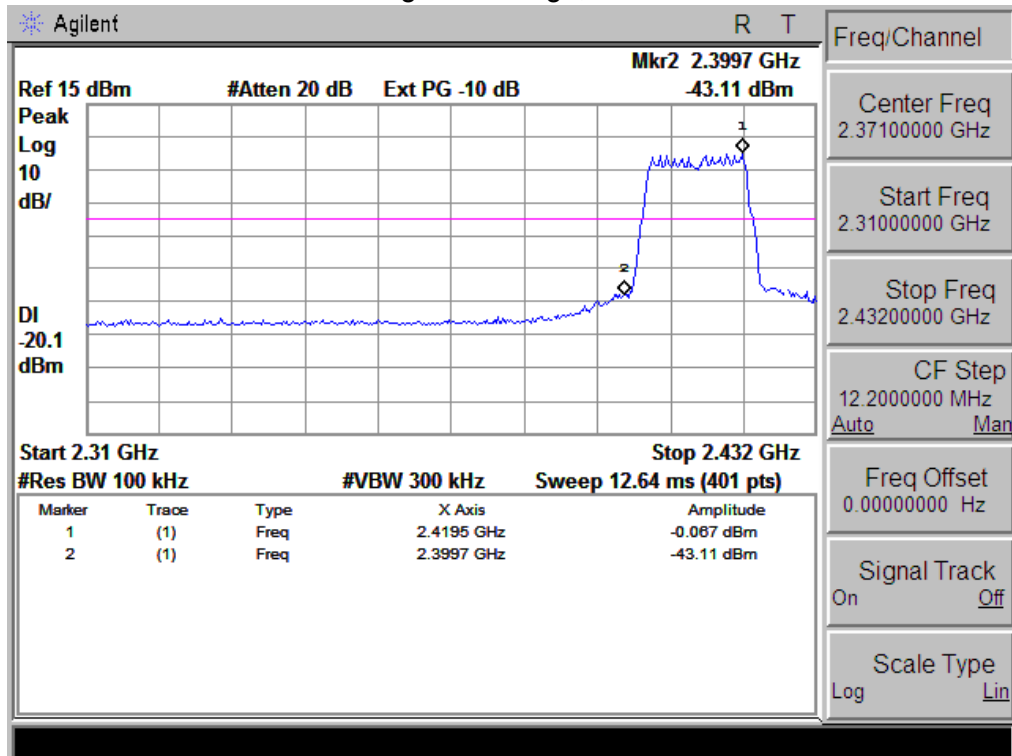

### 802.11g: Band Edge, Right Side

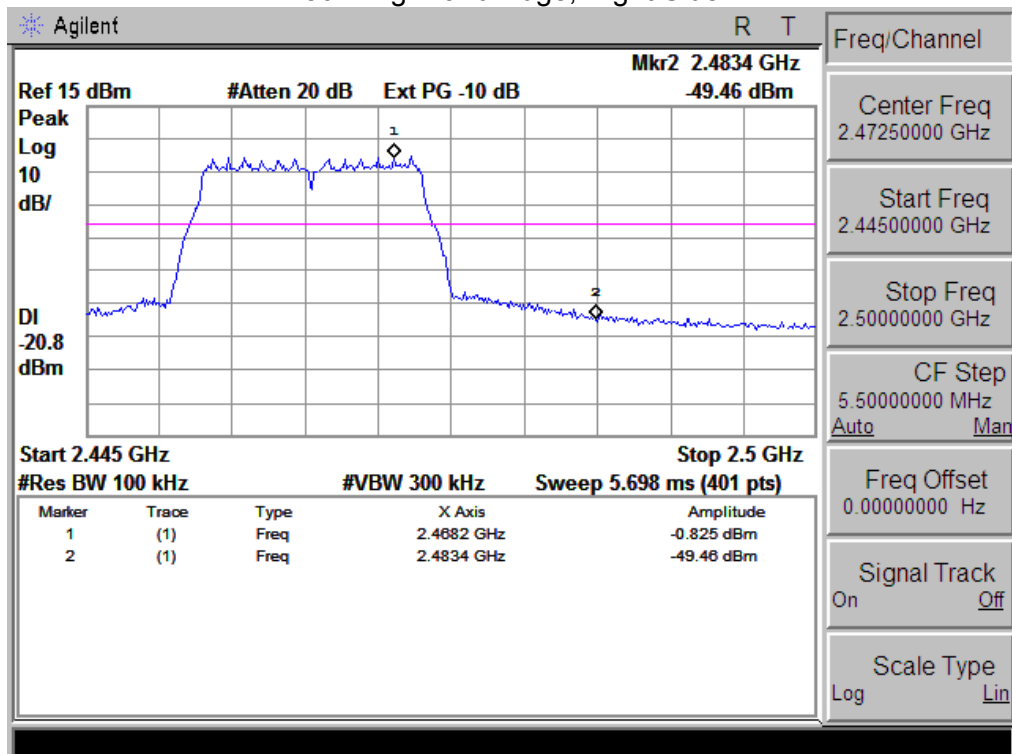

### 802.11n-HT20: Band Edge, Left Side

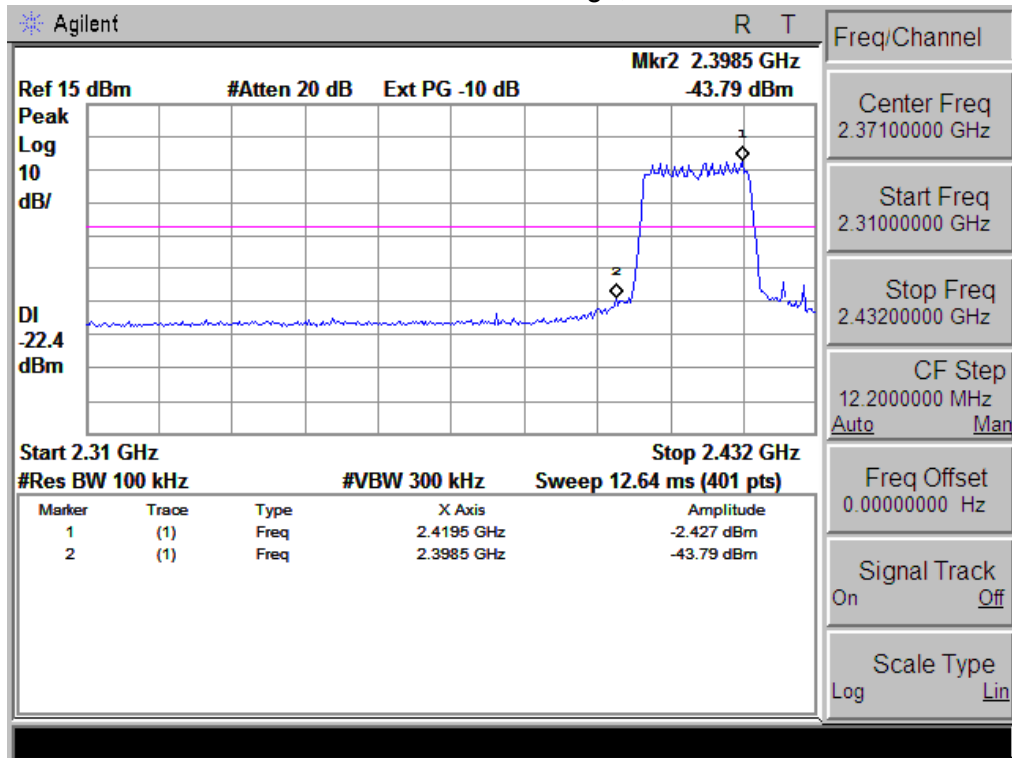

### 802.11n-HT20: Band Edge, Right Side

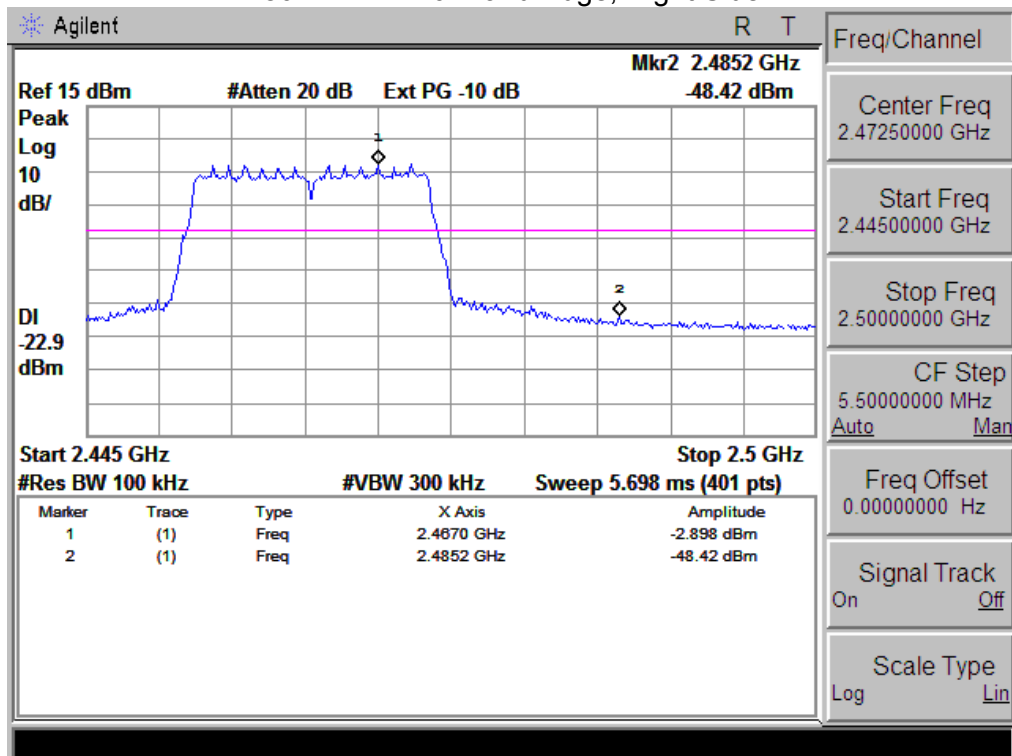

### 802.11n-HT40: Band Edge, Left Side

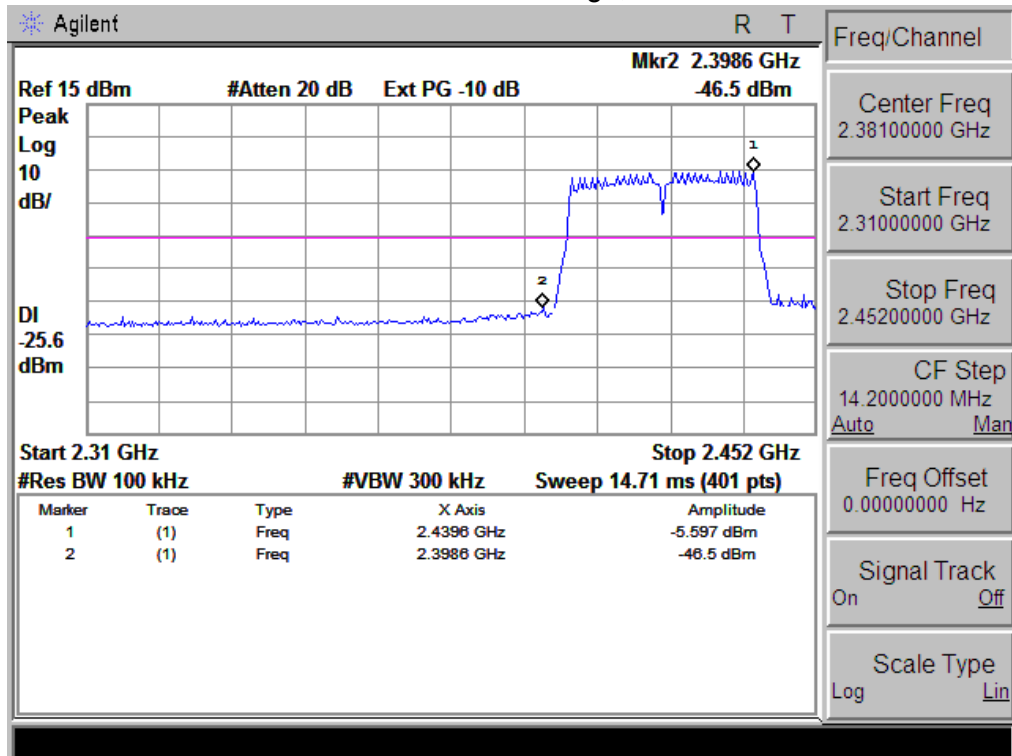

### 802.11n-HT40: Band Edge, Right Side

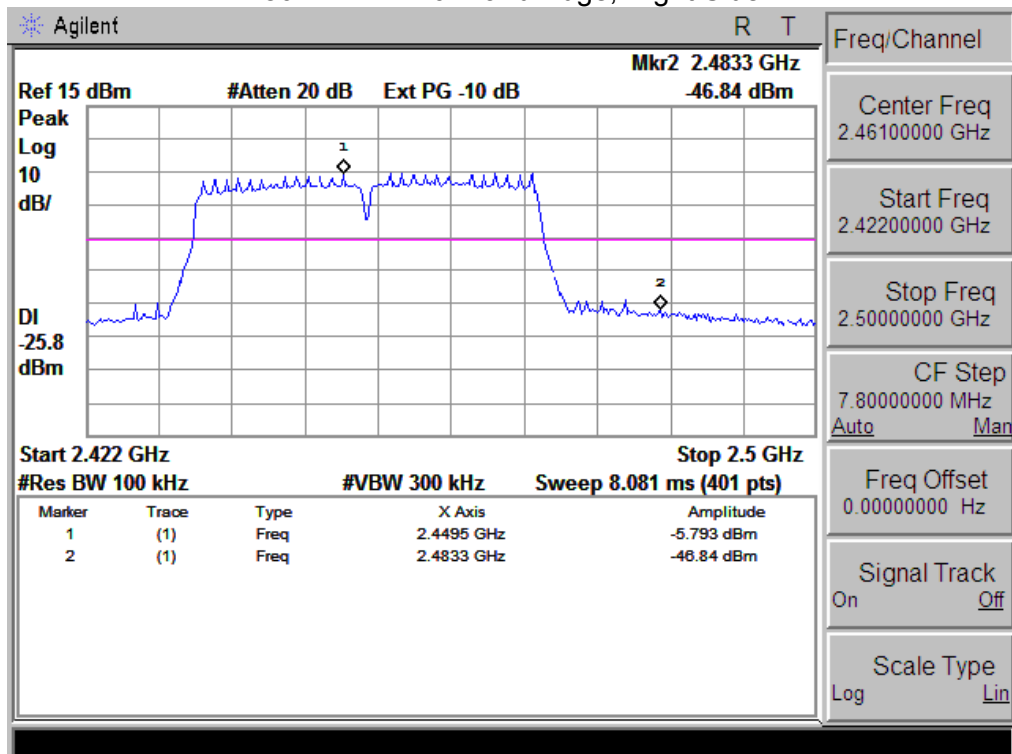

## **8. ANTENNA REQUIREMENT**

### **8.1 STANDARD REQUIREMENT**

15.203 requirement: For intentional device, according to 15.203: an intentional radiator shall be designed to ensure that no antenna other than that furnished by the responsible party shall be used with the device.

### **8.2 EUT ANTENNA**

The EUT antenna is FPCB antenna. It comply with the standard requirement.

**9. EUT TEST PHOTO**

**Radiated Measurement Photos**

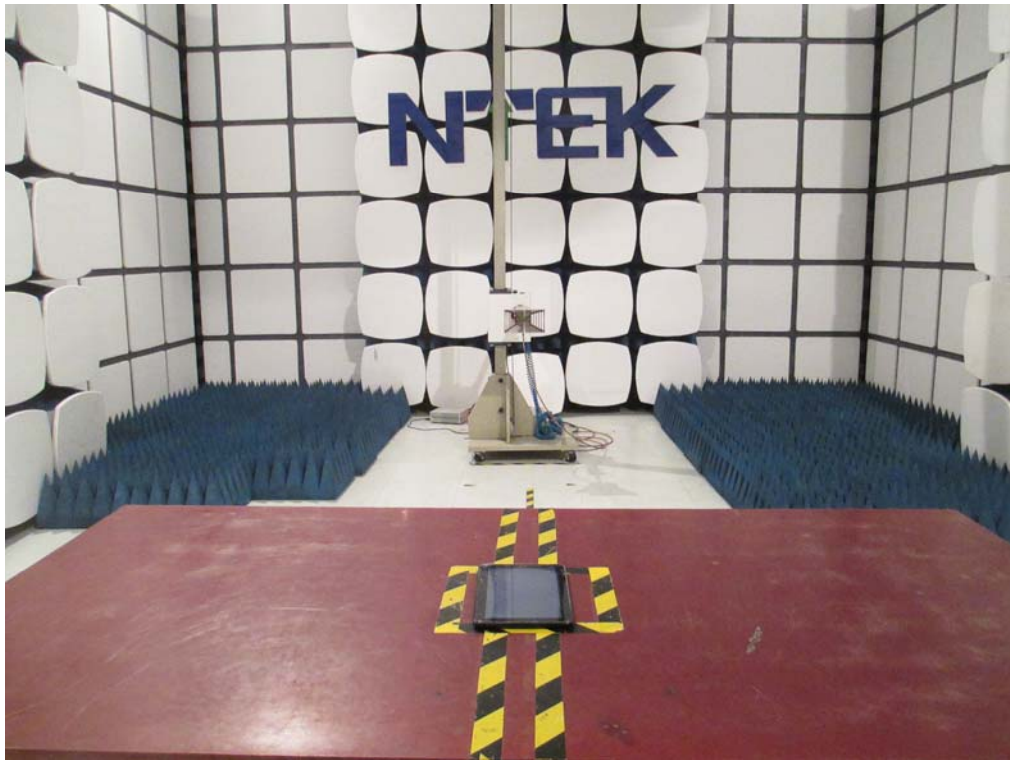
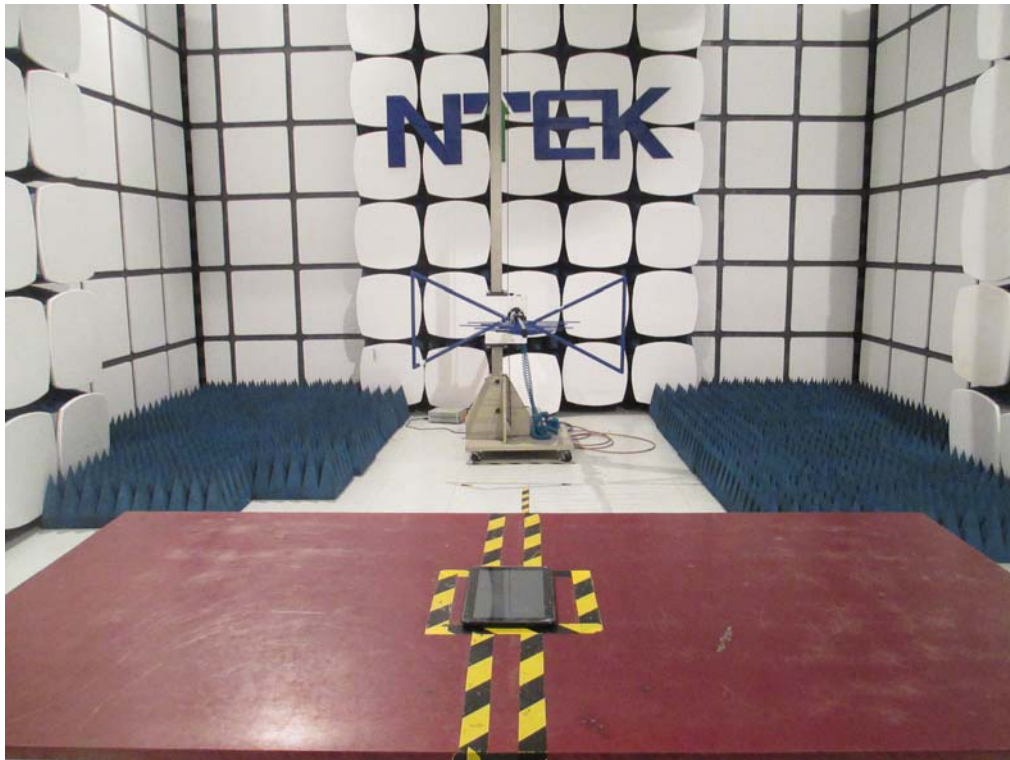



**Conducted Measurement Photo**

