

Getting Started

Safety Guidelines and Hardware Information

Safety

- Please keep the device right-side up and avoid placing heavy objects on top of the product.
- Please use the power adapter provided.
- Do not use damaged power cables or plugs.
- Please do not disassemble or modify the device by yourself to avoid any shock or damage.
- Please keep the device away from any heat source to avoid damage. The device should be kept in a dry, well-ventilated area away from any dust that may cause fire or electric shock.
- Please promptly shut down and unplug the device if smoke or any foul smell is emitted.
- Please unplug the device when not in use for long periods of time.

Accessories

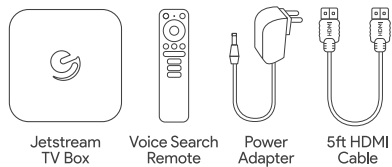

TV Box Panels

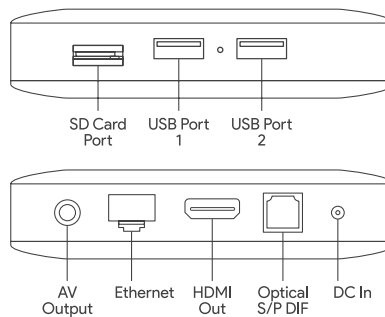

Remote

- ① Google Voice Search
- ② Power On/Off
- ③ Up/Down/Left/Right Direction Keys
- ④ Enter/Confirm
- ⑤ Back
- ⑥ Home
- ⑦ Menu
- ⑧ Volume
- ⑨ Youtube, Netflix, Google Play Shortcut Buttons

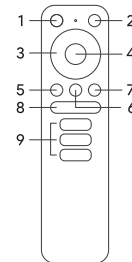

System Connection

Please refer to the diagram below for connecting your Jetstream TV Box to power, network and other devices. (Note: Before getting started, please shut down all equipment to be connected.)

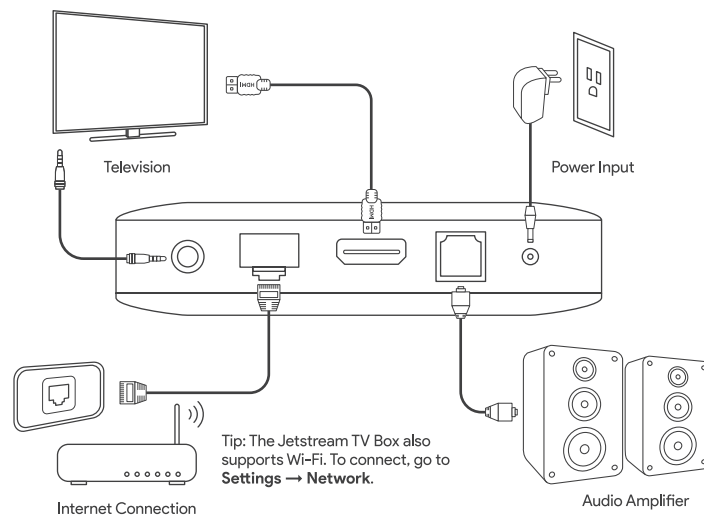

- STEP 1** Connect the Jetstream TV box to your television via HDMI Cable.
- STEP 2** Using an Ethernet Cable, connect the LAN Port of the TV Box to the LAN Port of your router or home broadband network.
- STEP 3** Connect the TV Box to power using the power adapter provided. You can then power on your device and begin.

Note: Before turning on your device, please switch the signal output of the TV to the correct source.

Setting Up Your Device

Step 1: Language

Select your preferred language on the Welcome Page.

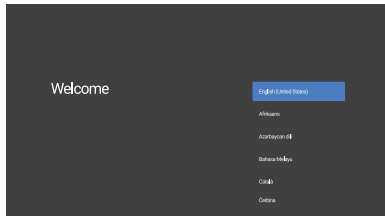

Step 2: Set up with Android device

Choose whether to set up your TV with an Android device or skip this step. If you choose Yes, please refer to Bluetooth Pairing on the next page.

Step 3: Wi-Fi

Connect to your Wi-Fi Network. Skip this step if already connected to Wi-Fi via ethernet.

Step 4: Google Account

Sign in with your Google Account.

Step 5: Terms of Service & Privacy Policy

Read and accept the Terms of Services & Private Policy.

Step 6: Location Settings

Choose whether to allow Google to use your location to improve experience.

Step 7: Diagnostic Report Settings

Select whether to allow your AndroidTV to send automatic diagnostic and usage data to Google.

Step 8: Meet your Google Assistant

Press the Google Assistant button on your remote to ask it questions or to tell it to do things like play your favorite show, video, or music.

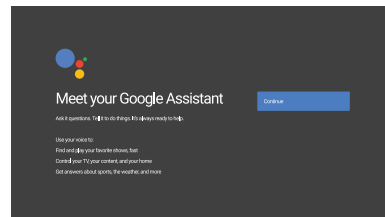

Step 9: Name your Android TV Box

Select from the options provided or enter a custom name to easily identify your device when pairing to other devices.

Step 10: Welcome to Android TV

A walkthrough of the features of your device.

Factory Data Reset

Under Settings, select Storage & Reset.

- Click Factory Data Reset to erase everything.
- Once this option has been selected, all manually installed apps and user data information will be deleted.

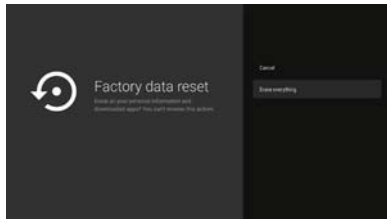

About

You can check information about your device by clicking on About in the Settings Menu. This panel will show you the model of your device, version, firmware version, device status and more.

You can also update your system by clicking on System Update from this menu.

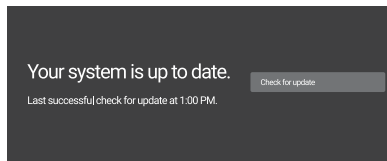

Downloading Apps

All apps are available for download on Google Play. Do not install apps via USB driver, SD card, or hard disk driver.

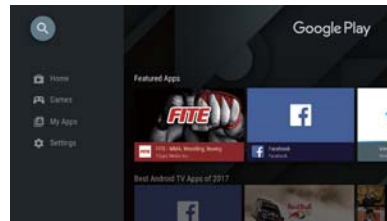

To Access Google Play:

- ① Scroll down to the Apps row on your Android TV Home Page.
- ② Select the Add Icon (+), then choose the Google Play Store from the list of options.
- ④ Once the Google Play Store app is added to your Android Home Page, you can then open the store to download more apps.

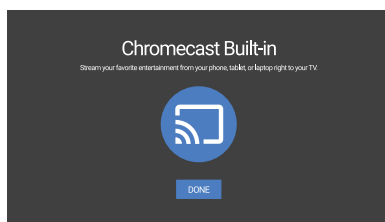

Click on "DONE" after the walkthrough to start using your device. You are now ready to begin.

Settings

Select Settings to check device information, add/remove accounts, and make changes to system settings.

Wifi Settings

Under Network Settings, select Wi-Fi and switch the on button to connect to Wi-Fi.

Once the device scans and lists nearby Wi-Fi networks, select the appropriate network name, input the password if required, and select Connect.

Language Settings

Under Settings > Preferences, select Language to change the language previously set.

Bluetooth Pairing

- Select Settings in the Menu Launcher.
- From the Remote & Accessories menu, click "Add Accessory" then select the device to be connected.

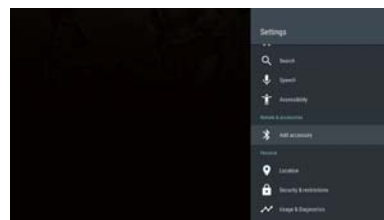

Unpairing a Bluetooth Device

- Select Settings from the Menu Launcher.
- From the Remote & Accessories menu, click "Unpair", then select the Bluetooth device you want to unpair.

Adding Accounts

For new Google users, sign up for a new Google account using the TV for easier login and payment security. Add an account or switch accounts under Accounts in the Settings Menu.

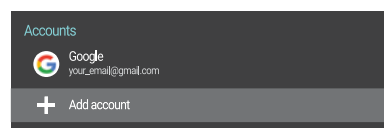

Use your phone as a remote.

Did you know that you can use your phone as a touchpad to easily navigate your screen instead of using the remote's directional buttons? You can even use your phone to type in that long movie title you wanted to search! How?

- ① Simply download the "Android TV Remote" app from Playstore or the App Store on your respective Android or Apple device. (Make sure your phone and the box are connected on the same Wi-Fi network.)
- ② Search and connect to your Android TV Box then input the code displayed on the TV into the device. You may now use your phone as a voice search remote.

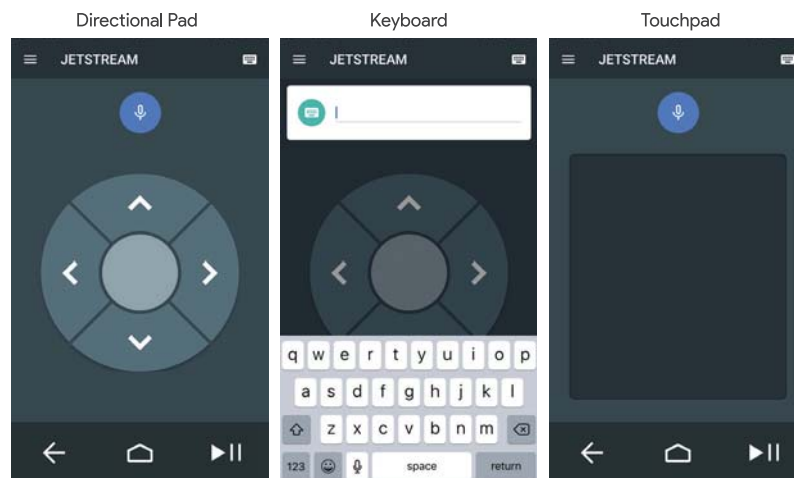

Google Cast

Cast from a Mobile Device

Certain apps allow you to cast to your TV. To cast, simply follow the following steps:

- ① Open a Googlecast compatible app on your mobile phone
- ② Navigate to the screen you wish to cast
- ③ Tap on the Cast icon  and then select your Android TV.

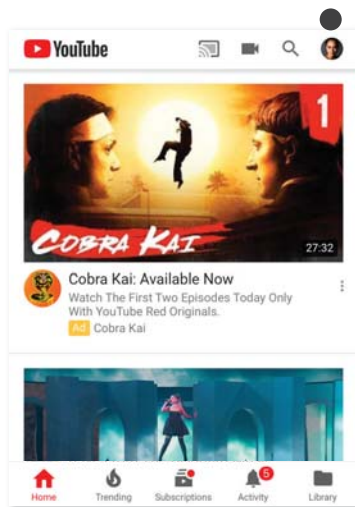

Cast from Google Chrome

This device has Google Chromecast built-in. To cast from Google Chrome, click the Settings icon  located on the top right corner of the browser, then click "Cast".

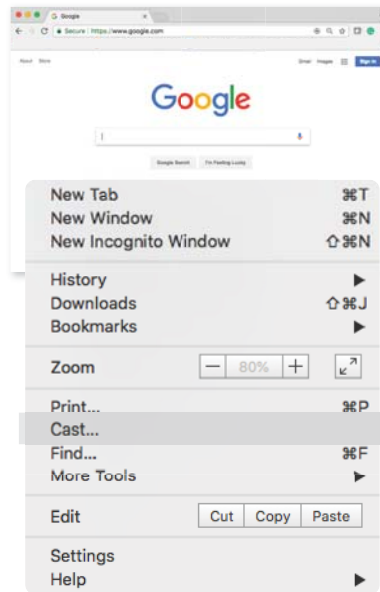

Google Assistant

Ask it questions. Tell it to do things.

Say it to Play it.

Ask it to play your favorite show, video, or music. Or find the latest blockbuster to enjoy.

Some things you can say:

"Text mom I'll be there in 5 minutes."
"What's the weather today?"

Control your AndroidTV:

"Look for Comedy Movies from 2006"
"Play Stranger Things Episode 2."
"Volume level 6."

Ask it to help plan your day:

"Wake me up at 8am tomorrow."
"How long will it take to get to work?"

Ask it about the latest news:

"Who won the World Cup?"
"What is the latest news from NPR?"

Control your home:

"Dim the lights in the bedroom"
"Are the lights on in the kitchen?"
"Pause the living room speakers."

Ask it anything:

"Where is the nearest gas station?"
"What is 52 times 26?"
"Tell me a fun fact."

To get started, press the Google Assistant button on your remote.

Speak into the microphone of your Voice Search remote.

Learn more about the Google Assistant on assistant.google.com

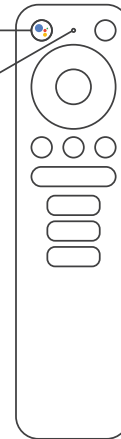

Hi, how can I help?

How do I say 'hello' in French?

'Hello' in French is Bonjour.

Simple Troubleshooting

Issue	Possible Reason	Solution
No display after power on	The power cord is not properly connected.	Make sure the device is connected to power.
No sound	Audio cable is not connected	Reconnect the cable.
	Device is on Mute or the volume is too low.	Press the mute button to restore the sound and increase the volume.
Failure to connect to Network	Ethernet cable is not properly connected.	Please reconnect the cable.
	Wi-Fi is turned off or the signal is too weak.	Please restart the Wi-Fi or adjust the position of the device closer to the router.
Remote Control Failure	The sensors of the remote control and the tv box are not in alignment.	Please aim the remote's sensor at the front panel's sensor and try again. Check for obstructions blocking the signal path between the remote and the box.
	Remote control is broken or the batteries are low in power.	Replace batteries or send the device to the local maintenance service station for checking.
No Picture on the screen	HDMI cable is not connected.	Make sure that HDMI/AV is selected as your tv input.



©Shaghal Ltd d/b/a Ematic ("Ematic"). All rights reserved. Android, Google, Google Play, YouTube, and Google Cast are trademarks of Google LLC. HDMI is a trademark of HDMI Licensing, LLC. Used with permission. PBS KIDS and the PBS KIDS Logo are registered trademarks of Public Broadcasting Service. Used with permission. HBO Now is a trademark of Home Box Office, Inc. Hulu is a trademark of Hulu, LLC. Showtime is a trademark of Showtime Networks Inc. Spotify is a trademark of Spotify Technology SA. WatchESPN is a trademark of ESPN Inc. NBA is a trademark of NBA Properties, Inc. Kodi is a trademark of XBMC Foundation. Netflix is a trademark of Netflix, Inc. Vudu is a trademark of Vudu, Inc. Dolby Audio is a trademark of Dolby Laboratories Licensing Corporation. This device complies with Part 15 of the FCC Rules. Operation is subject to the following two conditions: ① this device may not cause harmful interference, and ② this device must accept any interference received, including interference that may cause undesired operation. Ematic is not affiliated with Microsoft Corporation, Apple Inc., Google LLC, (including Android), or any of the above-listed entities. Your memory card's operating system may use a different standard of measurement than that of this device. Actual usable memory card capacity may vary. 1-year warranty from date of purchase. 90 days only on labor. The above-listed and any other third-party trademarks are the property of their respective owners. Shaghal Ltd. 2231 Colby Ave, Los Angeles, CA 90064. Manufactured 2018.

Technical Specifications

CPU	ARM Quad 64-bit Cortex-A53 up to 1.5GHz
Android OS	Android 8.1
Video Output	HDMI 2.0b, AV
Audio Output	Optical
Video Format	H.265 10-bit 4K*2K at 60fps, VP9 4K*2K at 60fps H.264, MPGE, MKV, MP4 and other video formats
Audio Format	AAC, WAV, MP3 and other audio formats
Photo Format	JPG, BMP, PNG and other photo formats
Network	Wi-Fi 2.4GHz/5GHz 802.11 a/b/g/n/ac RJ45 Interface 10M/100M adaptive
Operation Temperature	0°~40°
Power	Input: AC100-240V 50/60Hz Output: DC 5V/2A
Power Consumption	<8W

Customer Service

Visit Ematic.us/support for customer service regarding your product.

To submit a request, fill out the required information online. You will be provided with a ticket number regarding your issue which you can refer to when contacting us further. Thank you for buying an Ematic product!



Quick Start Guide

Please read before operating the TV Box.

FCC WARNING

This device complies with part 15 of the FCC Rules. Operation is subject to the following two conditions: (1) this device may not cause harmful interference, and (2) this device must accept any interference received, including interference that may cause undesired operation.

Any changes or modifications not expressly approved by the party responsible for compliance could void the user's authority to operate the equipment.

NOTE: This equipment has been tested and found to comply with the limits for a Class B digital device, pursuant to Part 15 of the FCC Rules. These limits are designed to provide reasonable protection against harmful interference in a residential installation. This equipment generates, uses and can radiate radio frequency energy and, if not installed and used in accordance with the instructions, may cause harmful interference to radio communications.

However, there is no guarantee that interference will not occur in a particular installation.

If this equipment does cause harmful interference to radio or television reception, which can be determined by turning the equipment off and on, the user is encouraged to try to correct the interference by one or more of the following measures:

- Reorient or relocate the receiving antenna.
- Increase the separation between the equipment and receiver.
- Connect the equipment into an outlet on a circuit different from that to which the receiver is connected.
- Consult the dealer or an experienced radio/TV technician for help.

To maintain compliance with FCC's RF Exposure guidelines, This equipment should be installed and operated with an minimum distance of 20 cm between the radiator and user's body: Use only the supplied antenna.