Sorenson Pulse

Setup Guide

Model: ADWAS-1986

Table of Contents

- Take Inventory 2
- Connect the Equipment 3
- Safety Instructions 5
- Regulatory Compliance 6

Version 1.0
April 19, 2018
Part No: 770-00002

Take Inventory

Step 1. Check For These Things First

You will need to have the following things ready and available near the location where you intend to set up your Sorenson Pulse device:

Sorenson ntouch VP2 Videophone or other ntouch Endpoint Device

The Sorenson Pulse flasher is designed for use with the Sorenson ntouch VP2 videophone or other ntouch endpoint device that supports wireless connections. A wireless connection between the Pulse and the ntouch endpoint allows the Pulse to flash a visual signal whenever an incoming call is received by the ntouch endpoint.

Electrical Outlet

You'll need a standard 120v AC electrical outlet located near your Pulse device. A power transformer is supplied with your videophone.

Step 2. Unpack the Shipping Box

Look for the following components packed in the shipping box:

Pulse Device

The Pulse device is a white circular plastic unit with a power port on its back side. Two slider switches are used to set the intensity of the two flasher systems in the device. A radio "pairing" button is located above the two slider switches.

DC Power Supply

The DC Power Supply (transformer) is a black rectangular device with an integral power cord that you will attach to the power port on the back side of the Pulse device. Do *not* use any other transformer with the Pulse device.

Step 3. Examine the Backside of the Pulse Device

Examine the back side of the Pulse device to identify its power port, flash intensity control switches, radio pairing button and wall-mount slot:

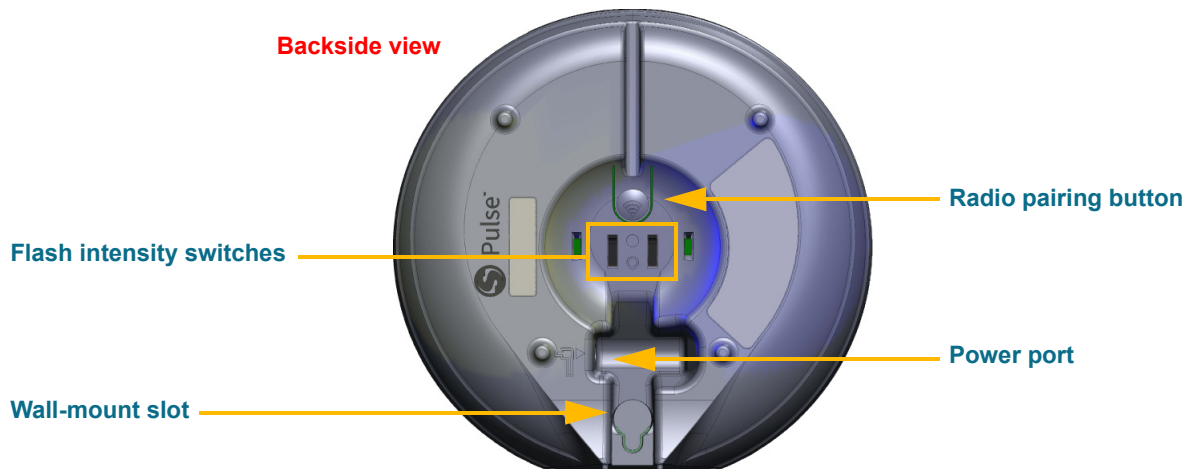

Connect the Equipment

Step 1. Find a good place to put the Pulse device.

Look around for a good place to set up your Pulse device. You'll need a stable table, counter, or shelf that's located near an available AC power outlet. Because the Pulse device connects wirelessly to the ntouch VP2 videophone (or other ntouch endpoint), you do not need to place the device near the videophone. Choose a convenient location where you will see the Pulse device when it flashes to alert you to an incoming videophone call.

You can place the Pulse device in a **vertical** or **horizontal** orientation or you can choose to **mount it to a wall** using the wall-mount slot located on the back side of the device.



Vertical (standing up)



Horizontal (lying down)

SignMail and Missed Call lights on front side of Pulse

Wall-mount

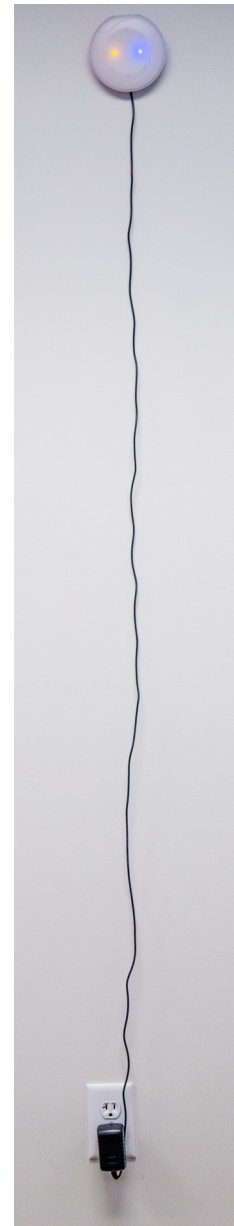

Also notice the **SignMail** and **Missed Calls** lights on the front-side of the Pulse device.

- Step 2.** Connect the DC Power Supply to the power port on the Pulse device.
- Step 3.** On the ntouch VP2 or other ntouch endpoint, open its Bluetooth pairing function.
The Pulse device can be paired to only one ntouch endpoint at a time. However, an ntouch endpoint can be paired to *multiple* Pulse devices at one time (such as multiple devices placed throughout your home or office).
- Step 4.** Briefly press the radio pairing button on the backside of the Pulse device. The device will enter the pairing mode. Use the pairing function on the ntouch endpoint to establish a connection between the Pulse device and the endpoint.
When the pairing function is complete on the ntouch endpoint, the setup of the Pulse device is complete.
- Step 5.** Choose a light intensity setting for both the LightRing and the Alert Flasher lights. Move the two switches on the back of the Pulse device to adjust the lights to the desired setting. Each switch has four positions: Off, Low, Medium, High
The High setting is located nearest to the Radio pairing button. The Low setting is located nearest to the power supply port. The selected lights will flash briefly as you move through the settings to demonstrate the brightness of each setting.

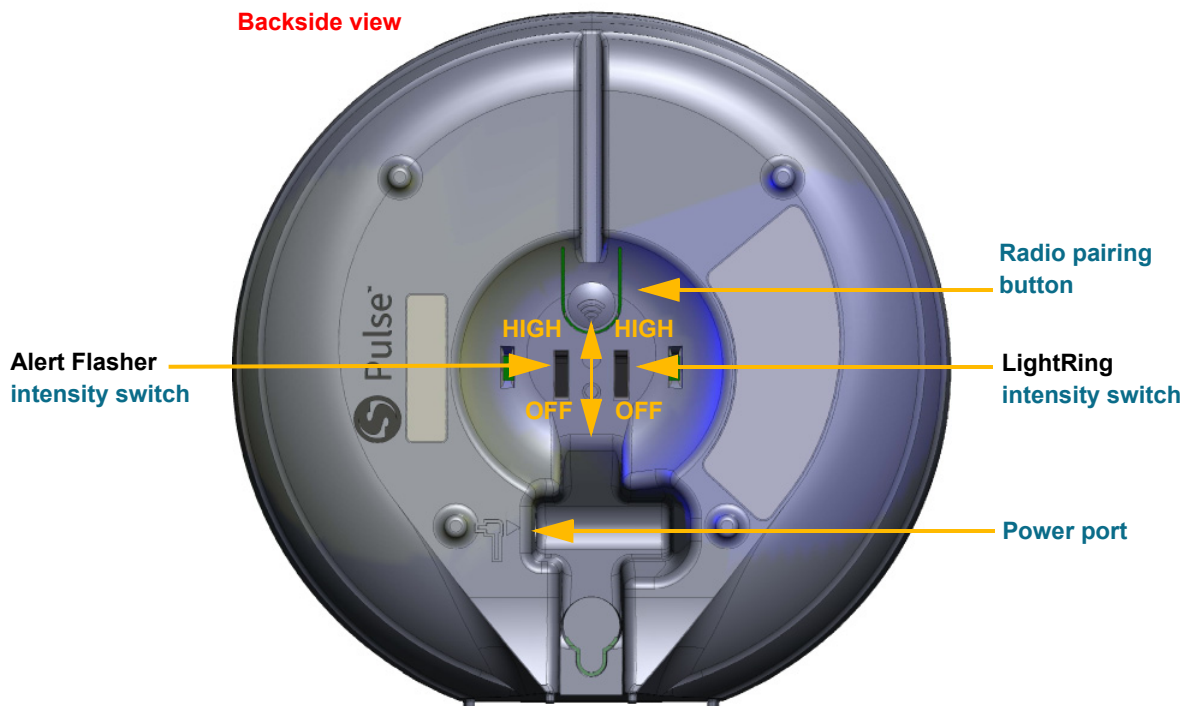

- Step 6.** Refer to your ntouch VP2 User Guide for details on setting the color and the flashing pattern of the LightRing. On all other ntouch endpoints, the LightRing lights will flash "white" in sync with the Alert Flasher lights on the Pulse device.
- Step 7.** Refer to your ntouch VP2 User Guide (or other ntouch endpoint User Guide) for details on understanding the meaning of the SignMail and Missed Call lights on the front side of the Pulse device. These lights will turn on to indicate you have new SignMail messages or have received missed calls on the ntouch endpoint.

Safety Instructions

Save these instructions for future reference.

To make sure that using your Pulse alert device is a safe and pleasant experience, please take the time to read, fully understand and follow each of these safety instructions:

- The Pulse device is to be used only with the included power supply. **Do not use any other power supply with the device.**
- The Pulse device has no on/off switch. To turn it off, disconnect its power supply.
- Carefully position the power cable connected to the Pulse so that it will not be accidentally pulled or tripped on by anyone.
- Be very careful not to drop the Pulse device to avoid damaging it or causing harm to yourself or to others.
- The intensity of the LightRing and Alert lights on the Pulse may appear to be very bright to you or to others. Remember to point the back side of the Pulse away from yourself and anyone else while you are adjusting the brightness of the lights.
- Carefully position the Pulse alert device on a wall, table, or another stable place away from any source of heat or moisture. The device is intended only for indoor use.
- Never use the Pulse near any source of water or while your hands are wet. Clean the outside of any part of the device only with a dry or very slightly damp cloth.
- To avoid the risk of an electric shock, do not disassemble the Pulse device. Do not attempt to open or service the device yourself. Contact Sorenson for servicing instructions if any part of the device is damaged, if any liquid has been spilled on any part of the device, or if the device does not appear to power on normally.
- If you experience any operating problems with the Pulse, call us for assistance.

WARNING: *Carefully follow these safety instructions to avoid personal injury and the chance of fire, electric shock, or other damage.*

Regulatory Compliance

FCC Compliance Statement

This device complies with part 15 of the FCC Rules. Operation is subject to the following two conditions: (1) This device may not cause harmful interference, and (2) this device must accept any interference received, including interference that may cause undesired operation.

Note: This equipment has been tested and found to comply with the limits for a Class B digital device, pursuant to part 15 of the FCC Rules. These limits are designed to provide reasonable protection against harmful interference in a residential installation. This equipment generates, uses and can radiate radio frequency energy and, if not installed and used in accordance with the instructions, may cause harmful interference to radio communications. However, there is no guarantee that interference will not occur in a particular installation. If this equipment does cause harmful interference to radio or television reception, which can be determined by turning the equipment off and on, the user is encouraged to try to correct the interference by one or more of the following measures:

- Reorient or relocate the receiving antenna.
- Increase the separation between the equipment and receiver.
- Connect the equipment into an outlet on a circuit different from that to which the receiver is connected.
- Consult the dealer or an experienced radio/TV technician for help.

This equipment complies with FCC radiation exposure limits.

Caution: Any changes or modifications not expressly approved by the party responsible for compliance to this equipment would void the user's authority to operate this device.

Wireless Radio Use

This device operates on the 2.4GHz frequency band. This equipment complies with FCC radiation exposure limits set forth for an uncontrolled environment. This transceiver must not be co-located or operating in conjunction with any other antenna or transmitter.

Responsible Party (Contact for FCC Matters)

Sorenson Communications, Inc.
Attn: FCC Liaison
4192 South Riverboat Road, Suite 100
Salt Lake City, UT, 84123 USA

Disposal and Recycling Information

All Sorenson product packaging materials may be recycled.

When the Pulse device is no longer needed, its plastic and metal parts may be recycled. Please check with local resources for information on how to properly dispose of the components of your Sorenson Pulse device.

RoHS

The Sorenson Pulse device is 100% RoHS compliant, and therefore free of the following hazardous materials: lead (Pb), mercury (Hg), cadmium (Cd), hexavalent chromium (CrVI), polybrominated biphenyls (PBB) and polybrominated diphenyl ethers (PBDE).