

## CONTENTS

X-Treme Roll  
Remote Control  
USB-C Cable

## BATTERY INSTALLATION

1. The remote control requires 3 AAA 1.5V batteries (not included).
2. Use a tool to press and hold the battery release button on the back of the remote control.
3. Slide down the battery cover.
4. Insert batteries as indicated in the diagram.
5. Slide the battery cover back into place securely.

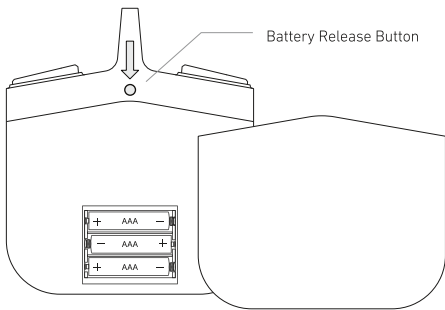

## PLAY

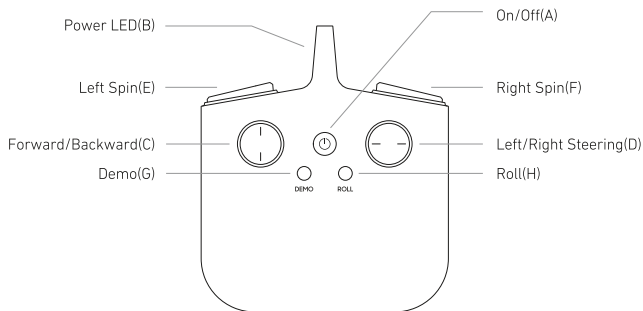

## CONTROLS

- A. Push button switch, power on/off.
- B. LED indication White LED, for remote working status indication.
- C. Push the left joystick forward to move the vehicle forward, push the joystick back to move the vehicle in reverse.
- D. Push the right joystick left or right to make the vehicle spin.
- E. Pressing the left spin button spins the vehicle counterclockwise.
- F. Pressing the right spin button spins the vehicle clockwise.
- G. Pressing the demo button will have the vehicle perform the demo function for 6 seconds. Press the button again to stop the demo function.
- H. Pressing the roll button activates the roll function.

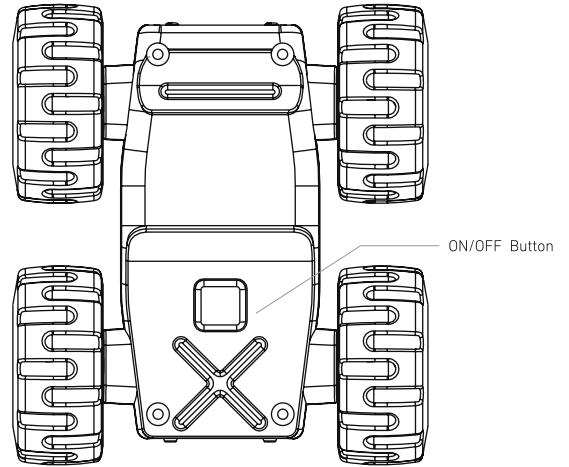

## POWER

- To power on the remote control, press the power switch from off to on. The power LED will light up.
- To power on the vehicle, press the power switch located at the bottom of the vehicle from off to on. The power LED on both sides of the vehicle will light up gradually.
- If there is no input for 5 minutes, both the vehicle and remote control will automatically shut off.

## PAIRING

- Power on both the vehicle and the remote control to automatically enter pairing mode. The white LEDs will flash slowly.
- Wait up to 1 minute for the white LEDs to quit flashing and remain solidly lit. This indicates the vehicle and remote control are successfully paired.
- If pairing is unsuccessful or the vehicle or remote control disconnect, restart both the vehicle and remote control to enter pairing mode again.

## CHARGING THE BATTERY

1. The RC X-Treme Roll uses a 3.7V LiPo rechargeable battery. Be sure to charge before play.
2. Attach the USB type-C cable that came included, into a power brick or appropriate power outlet.
3. Connect the other end of the cable to the USB-C opening located on the back of the vehicle.
4. When charging, the red LED on the RC will turn on and shut off when fully charged.
5. When the battery runs low, the vehicle will slow down by 50% and white LEDs will flash every 5 seconds.

Note: While the vehicle is charging, the vehicle will not take any input from the remote control even if they are paired.

## SAFETY WARNINGS: PLEASE READ BEFORE USE

- Adult assembly required.
- Do not touch spinning wheels or parts.
- Use this item only for its intended purpose.
- Do not expose to extreme temperatures or moisture.
- Thoroughly inspect products before every use. If the product appears worn, frayed/splintered, cracked, or broken in any manner, discontinue use and discard immediately.
- For indoor use only.
- Use caution and pay attention to your surrounding while operating this item.
- Always turn off when not in use.

## RECHARGEABLE BATTERY WARNINGS: NON-REPLACEABLE BATTERY

- This product contains batteries that are non-replaceable.
- There is a risk of fire and personal injury if battery is punctured, damaged, or misused.
- Do not dismantle, crush, incinerate or short-circuit battery.
- Never expose battery to extreme temperatures or moisture.
- Keep away from flammable materials and direct sunlight.
- Only charge using the provided charger, cable, and/or adapters.
- Rechargeable battery is only to be charged by an adult.
- Adult supervision is required while charging the battery.
- Allow battery to cool to room temperature before charging.
- Charge on a non-flammable surface and keep away from flammable products.
- Discontinue charging if battery becomes hot, swells, smokes, or gives off a strong odor.
- Battery chargers used with the product are to be regularly examined for damage to the cord, plug, enclosure, and other parts. In the event of such damage, chargers must not be used until the damage has been repaired.
- Recycle or dispose of battery according to federal, state, and local laws.
- Keep these instructions for future reference.

## BATTERY WARNING

- Do not mix old and new batteries.
- Do not mix alkaline, standard (carbon-zinc), or rechargeable batteries.
- Insert batteries using the correct polarity. Do not short-circuit the supply terminal.
- Remove batteries when not in use. Recycle or dispose of exhausted batteries according to federal, state, and local laws. Do not dispose of batteries in a fire - they may leak or explode.
- Only use manufacture specified battery(ies), charger(s) and/or adapter, if applicable, specified by the manufacturer.
- Always use, replace, and recharge (if applicable) batteries under adult supervision.
- Keep these instructions for future reference.

## FCC STATEMENT

This device complies with Part 15 of the FCC Rules. Operation is subject to the following two conditions: (1) this device may not cause harmful interference, and (2) this device must accept any interference received, including interference that may cause undesired operation.

**Warning:** Changes or modifications to this unit not expressly approved by the party responsible for compliance could void the user's authority to operate the equipment.

Note: This equipment has been tested and found to comply with the limits for a Class B digital device, pursuant to part 15 of the FCC Rules. These limits are designed to provide reasonable protection against harmful interference in a residential installation. This equipment generates, uses and can radiate radio frequency energy and, if not installed and used in accordance with the instructions, may cause harmful interference to radio communications.

However, there is no guarantee that interference will not occur in a particular installation. If this equipment does cause harmful interference to radio or television reception, which can be determined by turning the equipment off and on, the user is encouraged to try to correct the interference by one or more of the following measures:

- Reorient or relocate the receiving antenna.
- Increase the separation between the equipment and receiver.
- Connect the equipment into an outlet on a circuit different from that to which the receiver is connected.
- Consult the dealer or an experienced radio/TV technician for help.



### WARNING:

CHOKING HAZARD - Small Parts. Not For Children Under 3 Years of Age.

Model No.: 1016922

KEEP THIS INSTRUCTION MANUAL AS IT CONTAINS IMPORTANT INFORMATION FOR FUTURE REFERENCE.  
Due to continuous product improvements, the picture on the manual may differ slightly from the actual product.

Sharper Image® name and logo (including the 77 logo) are trademarks or registered trademarks. Distributed by and © 2022 MerchSource, LLC. Irvine, CA 92618. All rights reserved.

FOR CUSTOMER SUPPORT, PLEASE CALL

1-800-374-2744