

# FCC CDMA REPORT

## FCC Certification

**Applicant Name:**  
Franklin Technology Inc.**Date of Issue:**

July 11, 2016

**Location:**

HCT CO., LTD.,

**Address:**906 JEI Platz, 186, Gasan digital 1-ro, Geumcheon-gu,  
Seoul, Korea, (08502)74, Seoicheon-ro 578beon-gil, Majang-myeon,  
Icheon-si, Gyeonggi-do, 17383, Rep. of KOREA**Report No.:** HCT-R-1607-F014**HCT FRN:** 0005866421**FCC ID:** XHG-U772S**APPLICANT:** Franklin Technology Inc.**FCC Model(s):** U772  
**EUT Type:** LTE/CDMA USB Dongle  
**FCC Classification:** PCS Licensed Transmitter (PCB)  
**FCC Rule Part(s):** §90, §2

Mode	Tx Frequency (MHz)	Emission Designator	ERP	
			Max. Power (W)	Max. Power (dBm)
CDMA	817.90-823.1	1M27F9W	0.251	23.99
CDMA EVDO_Rev.0		1M28F9W	0.291	24.63
CDMA EVDO_Rev.A		1M28F9W	0.297	24.72

The measurements shown in this report were made in accordance with the procedures specified in CFR47 section§2.947. I assume full responsibility for the accuracy and completeness of these measurements, and for the qualifications of all persons taking them.

HCT CO., LTD. Certifies that no party to this application has subject to a denial of Federal benefits that includes FCC benefits pursuant to section 5301 of the Anti-Drug Abuse Act of 1998,21 U.S. C.853(a)

**Report prepared by**  
: Jeong Ho Kim  
Test engineer of RF Team**Approved by**  
: Kyoung Houn Seo  
Manager of RF Team

This report only responds to the tested sample and may not be reproduced, except in full, without written approval of the HCT Co., Ltd.

## Version

TEST REPORT NO.	DATE	DESCRIPTION
HCT-R-1607-F014	July 11, 2016	- First Approval Report

---

---

# Table of Contents

1. GENERAL INFORMATION .....	4
2. INTRODUCTION .....	5
2.1. EUT DESCRIPTION.....	5
2.2. MEASURING INSTRUMENT CALIBRATION.....	5
2.3. TEST FACILITY .....	5
3. DESCRIPTION OF TESTS .....	6
3.1 ERP RADIATED POWER AND RADIATED SPURIOUS EMISSIONS .....	6
3.2 OCCUPIED BANDWIDTH .....	7
3.3 SPURIOUS AND HARMONIC EMISSIONS AT ANTENNA TERMINAL.....	8
3.4 FREQUENCY STABILITY / VARIATION OF AMBIENT TEMPERATURE .....	9
4. LIST OF TEST EQUIPMENT .....	10
5. MEASUREMENT UNCERTAINTY .....	11
6. SUMMARY OF TEST RESULTS .....	12
7. SAMPLE CALCULATION .....	13
8. TEST DATA .....	14
8.1 EFFECTIVE RADIATED POWER .....	14
8.2 RADIATED SPURIOUS EMISSIONS .....	15
8.2.1 RADIATED SPURIOUS EMISSIONS (CDMA Mode) .....	15
8.3 OCCUPIED BANDWIDTH .....	16
8.4 CONDUCTED SPURIOUS EMISSIONS .....	17
8.4.1 Band Edge .....	17
8.5 FREQUENCY STABILITY / VARIATION OF AMBIENT TEMPERATURE .....	18
8.5.1 RADIATED SPURIOUS EMISSIONS (CDMA Mode) .....	18
9. TEST PLOTS.....	19

# MEASUREMENT REPORT

## 1. GENERAL INFORMATION

**Applicant Name:** Franklin Technology Inc.

**Address:** 906 JEI Platz, 186, Gasan digital 1-ro, Geumcheon-gu, Seoul, Korea, (08502)

**FCC ID:** XHG-U772S

**Application Type:** Certification

**FCC Classification:** PCS Licensed Transmitter (PCB)

**FCC Rule Part(s):** §90.691, §2

**EUT Type:** LTE/CDMA USB Dongle

**FCC Model(s):** U772

**Tx Frequency:** 817.90 — 823.1MHz (CDMA)

**Max. RF Output Power:** 0.251 W CDMA (23.99 dBm)/ 0.291 W CDMAEVDO\_Rev.0 (24.63dBm)  
/ 0.297 W CDMAEVDO\_Rev.A (24.72dBm)

**Emission Designator(s):** 1M27F9W (CDMA)/ 1M28F9W (CDMA EVDO\_Rev.0)/ 1M28F9W (CDMA EVDO\_Rev.A)

**Date(s) of Tests:** June 21, 2016 ~ July 08, 2016

**Antenna Specification**

Manufacturer:	HUTEC Co.,ltd
Antenna type:	Internal Antenna
Peak Gain:	0.237dBi

## **2. INTRODUCTION**

### **2.1. EUT DESCRIPTION**

The Franklin Technology Inc.U772 LTE/CDMA USB Dongle consists of Cellular CDMA, PCS CDMA, EVDO\_Rev.0 and EVDO\_Rev.A.

### **2.2. MEASURING INSTRUMENT CALIBRATION**

The measuring equipment, which was utilized in performing the tests documented herein, has been calibrated in accordance with the manufacturer's recommendations for utilizing calibration equipment, which is traceable to recognized national standards.

### **2.3. TEST FACILITY**

The Fully-anechoic chamber and conducted measurement facility used to collect the radiated data are located at the **74, Seoicheon-ro 578beon-gil, Majang-myeon, Icheon-si, Gyeonggi-do, 17383, Rep. of KOREA.**

## **3. DESCRIPTION OF TESTS**

### **3.1 ERP RADIATED POWER AND RADIATED SPURIOUS EMISSIONS**

Note: ERP(Effective Radiated Power)

Test Procedure

Radiated emission measurements are performed in the Fully-anechoic chamber. The equipment under test is placed on a non-conductive table 3-meters away from the receive antenna in accordance with ANSI/TIA-603-D-2010 Clause 2.2.17. The turntable is rotated through 360 degrees, and the receiving antenna scans in order to determine the level of the maximized emission. The level and position of the maximized emission is recorded with the spectrum analyzer using RMS detector.

A half wave dipole is then substituted in place of the EUT. For emissions above 1GHz, a horn antenna is substituted in place of the EUT. The substitute antenna is driven by a signal generator and the previously recorded signal was duplicated.

The power is calculated by the following formula;

$$P_{d(\text{dBm})} = P_{g(\text{dBm})} - \text{cable loss}_{(\text{dB})} + \text{antenna gain}_{(\text{dB})}$$

Where:  $P_d$  is the dipole equivalent power and  $P_g$  is the generator output power into the substitution antenna.

#### **Radiated spurious emissions**

1. Frequency Range : 30 MHz ~ 10<sup>th</sup> Harmonics of highest channel fundamental frequency.
2. The EUT was setup to maximum output power. The 100 kHz RBW was used to scan from 30 MHz to 1 GHz. Also, the 1 MHz RBW was used to scan from 1 GHz to 10 GHz(Cellular CDMA). The high, low and a middle channel were tested for out of band measurements.

Note : This device was tested under all R.C.s and S.O.s and worst case is reported with 'All Up' power control bits.

### 3.2 OCCUPIED BANDWIDTH.

#### Test set-up

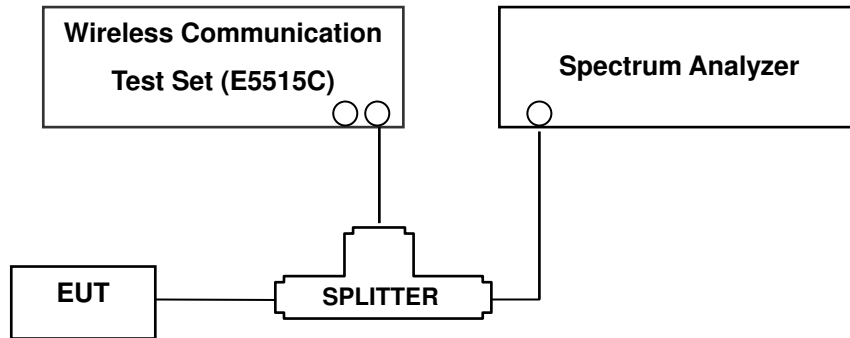

(Configuration of conducted Emission measurement)

The width of a frequency band such that, below the lower and above the upper frequency limits, the mean powers emitted are each equal to a specified percentage 0.5 % of the total mean power of a given emission.

#### Test Procedure

OBW is tested in accordance with KDB971168 D01 Power Meas License Digital Systems v02r02, October 17, 2014, Section 4.2..

The EUT makes a call to the communication simulator. The power was measured with R&S Spectrum Analyzer. All measurements were done at 3 channels (low, middle and high operational range.)

The conducted occupied bandwidth used the power splitter via EUT RF power connector between simulation base station and spectrum analyzer.

The communication simulator station system controlled a EUT to export maximum output power under transmission mode and specific channel frequency. Use OBW measurement function of Spectrum analyzer to measure 99 % occupied bandwidth

Note : This device was tested under all R.C.s and S.O.s and worst case is reported with 'All Up' power control bits.

### 3.3 SPURIOUS AND HARMONIC EMISSIONS AT ANTENNA TERMINAL.

#### Test Procedure

The level of the carrier and the various conducted spurious and harmonic frequencies is measured by means of a calibrated spectrum analyzer.

The EUT was setup to maximum output power at its lowest channel. The Resolution BW of the analyzer is set to <1 % of the emission bandwidth to show compliance with the – 13 dBm limit, in the 1 MHz bands immediately outside and adjacent to the edge of the frequency block. The 1 MHz RBW was used to scan from 10 MHz to 10 GHz. (GSM1900 Mode: 10 MHz to 20 GHz). A display line was placed at – 13 dBm to show compliance. The high, lowest and a middle channel were tested for out of band measurements.

- Band Edge Requirement : In the 1MHz bands immediately outside and adjacent to the frequency block, a resolution bandwidth of at least 1 percent of the emission bandwidth of the fundamental emission of the transmitter may be employed to measure the out of band Emissions. Limit, -13dBm.

Note : This device was tested under all R.C.s and S.O.s and worst case is reported with 'All Up' power control bits.

**NOTES:** The analyzer plot offsets were determined by below conditions.

- For CDMA, total offset 26.5 dB = 20 dB attenuator + 6 dB Splitter + 0.5 dB RF cables,



### 3.4 FREQUENCY STABILITY / VARIATION OF AMBIENT TEMPERATURE

#### Test Set-up

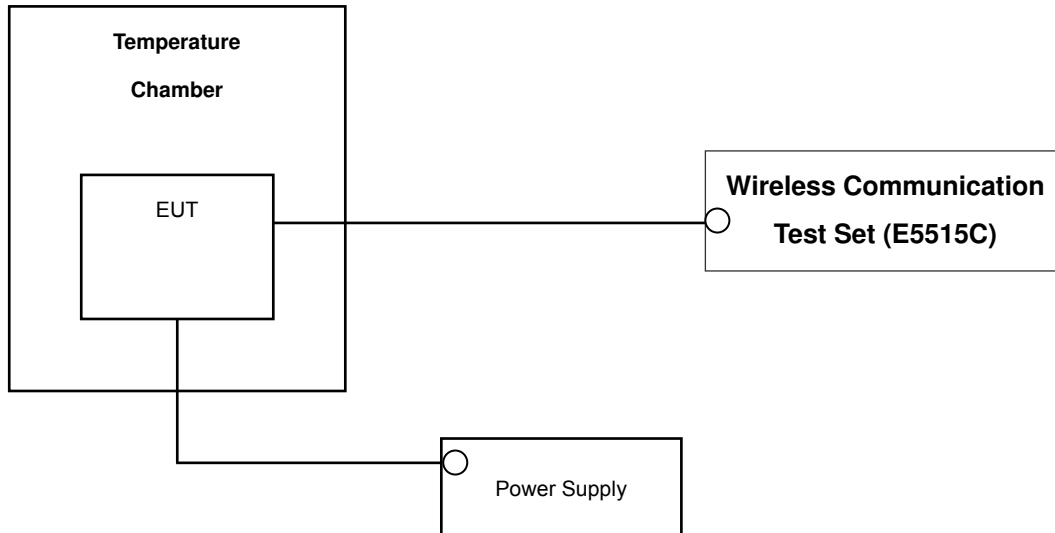

\* Nominal Operating Voltage

#### Test Procedure

Frequency stability is tested in accordance with ANSI/TIA-603-D-2010 section 2.2.2.

The frequency stability of the transmitter is measured by:

- a.) **Temperature:** The temperature is varied from - 30 °C to + 50 °C using an environmental chamber.
- b.) **Primary Supply Voltage:** The primary supply voltage is varied from battery end point to 100 % of the voltage normally at the input to the device or at the power supply terminals if cables are not normally supplied.

Specification — the frequency stability of the transmitter shall be maintained within  $\pm 0.00025\%$  ( $\pm 2.5$  ppm) of the center frequency (Cellular CDMA).

#### Time Period and Procedure:

The carrier frequency of the transmitter is measured at room temperature (20°C to provide a reference).

1. The equipment is turned on in a "standby" condition for one minute before applying power to the transmitter. Measurement of the carrier frequency of the transmitter is made within one minute after applying power to the transmitter.
2. Frequency measurements are made at 10°C intervals ranging from -30°C to +50°C. A period of at least one half-hour is provided to allow stabilization of the equipment at each temperature level.

**NOTE: The EUT is tested down to the battery endpoint.**

Note : This device was tested under all R.C.s and S.O.s and worst case is reported with 'All Up' power control bits.

## 4. LIST OF TEST EQUIPMENT

Manufacture	Model/ Equipment	Serial Number	Calibration Interval	Calibration Due
CERNEX	CBLU1183540B-01/ POWER AMP	25540	Annual	05/13/2017
Wainwright	WHKX 10-900-1000-15000-40SS/H.P.F	5	Annual	08/11/2016
Wainwright	WHKX10-2700-3000-18000-40SS/H.P.F	3	Annual	08/05/2016
Hewlett Packard	11667B / Power Splitter	10545	Annual	02/15/2017
Hewlett Packard	11667B / Power Splitter	11275	Annual	04/29/2017
ITECH	IT6720/ Power Supply	0100215626700119	Annual	11/02/2016
Schwarzbeck	UHAP/ Dipole Antenna	557	Biennial	03/23/2017
Schwarzbeck	UHAP/ Dipole Antenna	558	Biennial	03/23/2017
EXP	EX-TH400/ Chamber	None	Annual	05/31/2017
Schwarzbeck	BBHA 9120D/ Horn Antenna	9210D-1298	Biennial	10/16/2016
Schwarzbeck	BBHA 9120D/ Horn Antenna	9210D-1299	Biennial	10/16/2016
Schwarzbeck	BBHA 9170/ Horn Antenna(15~40GHz)	BBHA9170342	Biennial	04/30/2017
Schwarzbeck	BBHA 9170/ Horn Antenna(15~35GHz)	BBHA9170124	Biennial	04/30/2017
Agilent	N9020A/Signal Analyzer	MY52090906	Annual	05/13/2017
Hewlett Packard	8493C/ATTENUATOR	17280	Annual	06/22/2017
REOHDE&SCHWARZ	FSV40-N/Signal Analyzer	101068-SZ	Annual	09/23/2016
Agilent	8960 (E5515C)/ Base Station	MY48360800	Annual	10/30/2016
Anritsu Corp.	MT8820C/Wideband Radio Communication Tester	6200863156	Annual	02/26/2017
Anritsu Corp.	MT8820C/Wideband Radio Communication Tester	6201026545	Annual	02/16/2017
Schwarzbeck	VULB9160/ Bilog Antenna	3150	Biennial	11/17/2016
Schwarzbeck	VULB9160/ Bilog Antenna	3368	Biennial	10/10/2016

## 5. MEASUREMENT UNCERTAINTY

The measurement uncertainties shown below were calculated in accordance with the requirements of ANSI C63.4:2014.

All measurement uncertainty values are shown with a coverage factor of  $k = 2$  to indicate a 95 % level of confidence. The measurement data shown herein meets or exceeds the  $U_{\text{CISPR}}$  measurement uncertainty values specified in CISPR 16-4-2 and, thus, can be compared directly to specified limits to determine compliance.

Parameter	Expanded Uncertainty ( $\pm$ dB)
Conducted Disturbance (150 kHz ~ 30 MHz)	1.82
Radiated Disturbance (9 kHz ~ 30 MHz)	3.40
Radiated Disturbance (30 MHz ~ 1 GHz)	4.80
Radiated Disturbance (1 GHz ~ 18 GHz)	6.07

## 6. SUMMARY OF TEST RESULTS

FCC Part Section(s)	Test Description	Test Limit	Test Condition	Test Result
2.1051	Occupied Bandwidth	N/A	CONDUCTED	PASS
2.1051, 90.691	Band Edge / Spurious and Harmonic Emissions at Antenna Terminal.	<50 + 10log <sub>10</sub> (P[Watts]) at Band Edge and for all out-of-band emissions within 37.5KHz of Block Edge		PASS
2.1046	Conducted Output Power	N/A		PASS
2.1055, 90.213	Frequency stability / variation of ambient temperature	< 2.5 ppm		PASS
90.635	Effective Radiated Power	<100 Watts max. ERP	RADIATED	PASS
2.1053, 90.691	Radiated Spurious and Harmonic Emissions	< 43 + 10log <sub>10</sub> (P[Watts]) for all out-of band emissions		PASS

\*: See SAR Report

## 7. SAMPLE CALCULATION

### A. ERP Sample Calculation

Mode	Ch./ Freq.		Measured Level(dBm)	Substitute LEVEL(dBm)	Ant. Gain	C.L	Pol.	Limit	ERP	
	channel	Freq.(MHz)						W	W	dBm
CDMA	580	820.5	-32.96	28.98	-10.61	0.88	V	< 100.00	0.056	17.49

**ERP = Substitute LEVEL(dBm) + Ant. Gain– CL(Cable Loss)**

- 1) The EUT mounted on a wooden tripod is 0.8 meter above test site ground level.
- 2) During the test , the turntable is rotated and the antenna height is also varied from 1 to 4 meters until the maximum signal is found.
- 3) Record the field strength meter's level.
- 4) Replace the EUT with dipole/Horn antenna that is connected to a calibrated signal generator.
- 5) Increase the signal generator output till the field strength meter's level is equal to the item (3).
- 6) The signal generator output level with Ant. Gain and cable loss are the rating of effective radiated power (**ERP**).

## B. Emission Designator

### CDMA Emission Designator

**Emission Designator = 1M27F9W**

CDMA BW = 1.27 MHz

(Measured at the 99% power bandwidth)

F = Frequency Modulation

9 = Composite Digital Info

W = Combination (Audio/Data)

### EVDO Emission Designator

**Emission Designator = 1M27F9W**

CDMA BW = 1.27 MHz

(Measured at the 99% power bandwidth)

F = Frequency Modulation

9 = Composite Digital Info

W = Combination (Audio/Data)

## 8. TEST DATA

### 8.1 EFFECTIVE RADIATED POWER

Mode	Ch./ Freq.		Measured Level (dBm)	Substitute LEVEL (dBm)	Ant. Gain (dBd)	C.L	Pol.	Limit W	ERP	
	channel	Freq.(MHz)							W	dBm
CDMA	476	817.9	-26.13	36.01	-10.24	1.78	H	< 100.00	0.251	23.99
	580	820.5	-26.35	35.82	-10.24	1.79	H		0.239	23.79
	684	823.1	-26.50	35.67	-10.23	1.79	H		0.232	23.65
EVDO Rev.0	476	817.9	-25.49	36.65	-10.24	1.78	H		0.291	24.63
	580	820.5	-25.69	36.48	-10.24	1.79	H		0.278	24.45
	684	823.1	-25.69	36.48	-10.23	1.79	H		0.279	24.46
EVDO Rev.A	476	817.9	-25.40	36.74	-10.24	1.78	H		0.297	24.72
	580	820.5	-25.46	36.71	-10.24	1.79	H		0.293	24.68
	684	823.1	-25.61	36.56	-10.23	1.79	H		0.284	24.54

**NOTES:**

Effective Radiated Power Output Measurements by Substitution Method  
according to ANSI/TIA/EIA-603-D-2010 June 24, 2010:

The EUT was placed on a non-conductive styrofoam resin table 3-meters from the receive antenna. The receive antenna height and turntable rotation was adjusted for the highest reading on the receive spectrum analyzer. For CDMA signals, RBW = 1-5% of the OBW, not to exceed 1MHz, VBW ≥ 3 x RBW, Detector = RMS. A half-wave dipole was substituted in place of the EUT. This dipole antenna was driven by a signal generator and the level of the signal generator was adjusted to obtain the same receive spectrum analyzer reading. The conducted power at the terminals of the dipole is measured. The ERP is recorded.

This device was tested under all configurations and the highest power is reported. Also, we have done x, y, z planes in EUT and horizontal and vertical polarization in detecting antenna. The worst case of the EUT is in x plane in CDMA mode, CDMA EVDO\_Rev.0 mode and CDMA EVDO\_Rev.A mode. Also worst case of detecting Antenna is in horizontal polarization in CDMA mode, CDMA EVDO\_Rev.0 mode and CDMA EVDO\_Rev.A mode.

## 8.2 RADIATED SPURIOUS EMISSIONS

### 8.2.1 RADIATED SPURIOUS EMISSIONS (CDMA Mode)

- MEASURED OUTPUT POWER: 24.72 dBm = 0.297 W
- MODULATION SIGNAL: CDMAEVDO Rev.A
- DISTANCE: 3 meters
- LIMIT:  $43 + 10 \log_{10}(W) =$  37.72dBc

Ch.	Freq.(MHz)	Measured Level [dBm]	Ant. Gain (dBd)	Substitute Level [dBm]	C.L	Pol.	ERP (dBm)	dBc
476 (817.9)	1,635.80	-49.62	9.11	-61.15	2.31	V	-54.36	79.08
	2,453.70	-53.45	10.91	-60.77	2.72	H	-52.58	77.30
	3,271.60	-53.96	11.88	-59.38	3.09	V	-50.59	75.31
580 (820.5)	1,641.00	-49.65	9.12	0.00	2.32	V	-54.54	79.26
	2,461.50	-53.64	10.91	-61.15	2.74	V	-52.66	77.38
	3,282.00	-54.41	11.90	-60.77	3.17	V	-51.06	75.78
684 (823.1)	1,646.20	-49.10	9.16	0.55	2.32	V	-53.97	78.69
	2,469.30	-53.05	10.92	-61.34	2.73	H	-52.38	77.10
	3,292.40	-54.29	11.92	-60.83	3.12	V	-51.18	75.90

- NOTES:**
1. Radiated Spurious Emission Measurements at 3 meters by Substitution Method according to ANSI/TIA/EIA-603-D-2010 Jun 24, 2010:
  2. We are performed all frequency to 10<sup>th</sup> harmonics from 30 MHz. Measurements above show only up to 3 maximum emissions noted, or would be lesser if no specific emissions from the EUT are recorded (ie: margin > 20 dB from the applicable limit) and considered that's already beyond the background noise floor.
  3. We have done x, y, z planes in EUT and horizontal and vertical polarization in detecting antenna.

### 8.3 OCCUPIED BANDWIDTH

Band	Channel	Frequency(MHz)	Data (MHz)
CDMA	476	817.9	1.2698
	580	820.5	1.2727
	684	823.1	1.2744
CDMA EVDO_Rev.0	476	817.9	1.2759
	580	820.5	1.2758
	684	823.1	1.2793
CDMA EVDO_Rev.A	476	817.9	1.2780
	580	820.5	1.2746
	684	823.1	1.2750

- Plots of the EUT's Occupied Bandwidth are shown Page 20 ~ 24.



## 8.4 CONDUCTED SPURIOUS EMISSIONS

### ■FACTORS FOR FREQUENCY

Frequency Range (GHz)	Factor [dB]
0.03 – 1	27.145
1 – 5	26.960
5 – 10	27.542
10 – 15	28.439
15 – 20	29.144
Above 20	30.148

### NOTES:

Factor(dB) = Cable Loss + Attenuator +Power Splitter

Band	Channel	Frequency of Maximum Harmonic (GHz)	Factor (dB)	Measurement Maximum Data (dBm)	Result (dBm)	Limit (dBm)
CDMA	476	2.4552	26.96	-75.7	-48.74	-13.00
	580	2.4622	26.96	-75.1	-48.14	
	684	2.4697	26.96	-76.0	-49.04	
CDMA EVDO_Rev.0	476	2.4537	26.96	-72.8	-45.84	
	580	2.4617	26.96	-71.6	-44.64	
	684	2.4707	26.96	-72.4	-45.44	
CDMA EVDO_Rev.A	476	2.4537	26.96	-73.5	-46.54	
	580	2.4617	26.96	-72.4	-45.44	
	684	2.4702	26.96	-73.0	-46.04	

### NOTES:

1. Result (dBm) = Measurement Maximum Data (dBm) + Factor (dB)

- Plots of the EUT's Conducted Spurious Emissions are shown Page 30 ~ 34.

### 8.4.1 Band Edge

- Plots of the EUT's Band Edge are shown Page 24 ~ 30.

## 8.5 FREQUENCY STABILITY / VARIATION OF AMBIENT TEMPERATURE

### 8.5.1 RADIATED SPURIOUS EMISSIONS (CDMA Mode)

- ▣ OPERATING FREQUENCY: 820.500,000 Hz
- ▣ CHANNEL: 580
- ▣ REFERENCE VOLTAGE: 5.00 VDC
- ▣ DEVIATION LIMIT: ± 0.000 25 % or 2.5 ppm

Voltage (%)	Power (VDC)	Temp. (°C)	Frequency (Hz)	Frequency Error (Hz)	Deviation (%)	ppm
100%	5.00	+20(Ref)	820 499 993	0.00	0.000 000	0.000
100%		-30	820 499 984	-9.07	-0.000 001	-0.011
100%		-20	820 499 985	-8.10	-0.000 001	-0.010
100%		-10	820 499 987	-6.37	-0.000 001	-0.008
100%		0	820 499 986	-6.56	-0.000 001	-0.008
100%		+10	820 499 986	-6.70	-0.000 001	-0.008
100%		+30	820 499 987	-6.23	-0.000 001	-0.008
100%		+40	820 499 988	-4.88	-0.000 001	-0.006
100%		+50	820 499 986	-7.16	-0.000 001	-0.009
Batt. Endpoint	4.75	+20	820 499 985	-7.93	-0.000 001	-0.010

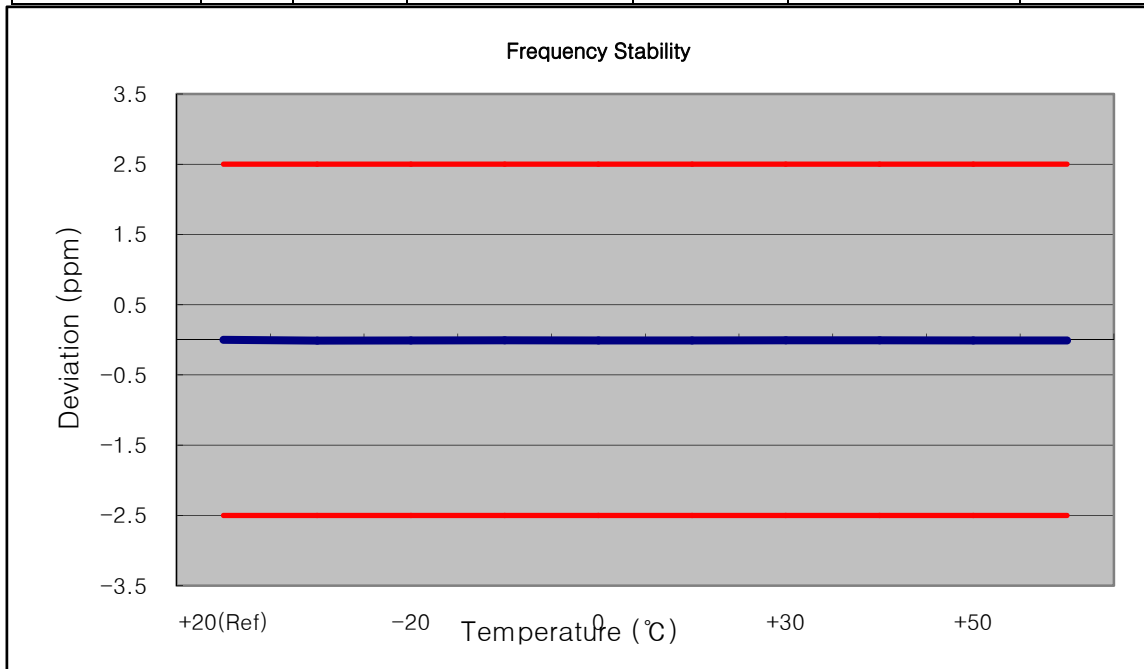

## 9. TEST PLOTS

■ Secondary MODE (476 CH.) Occupied Bandwidth

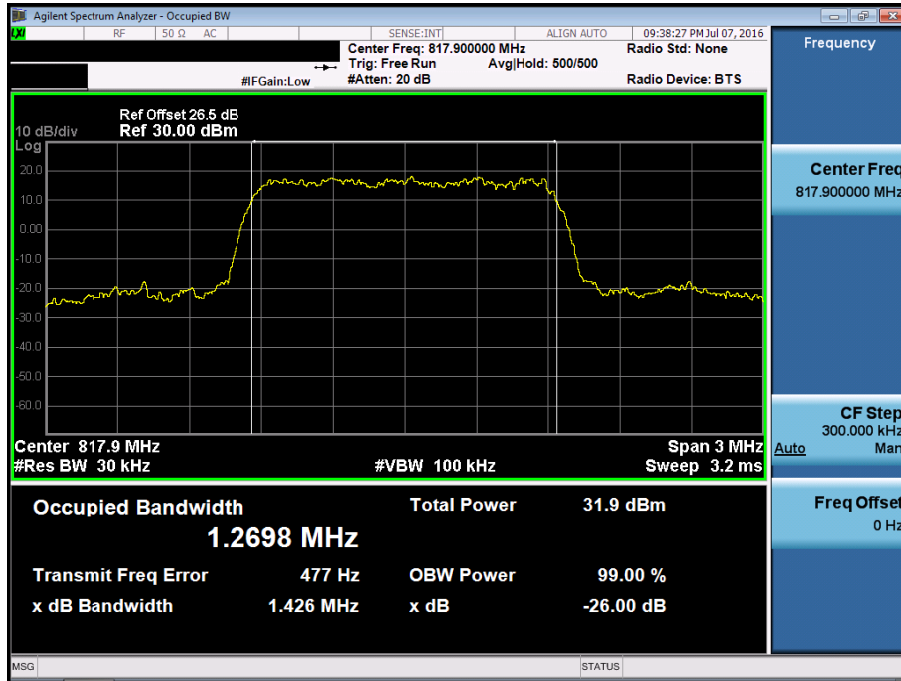

■ Secondary MODE (580 CH.) Occupied Bandwidth

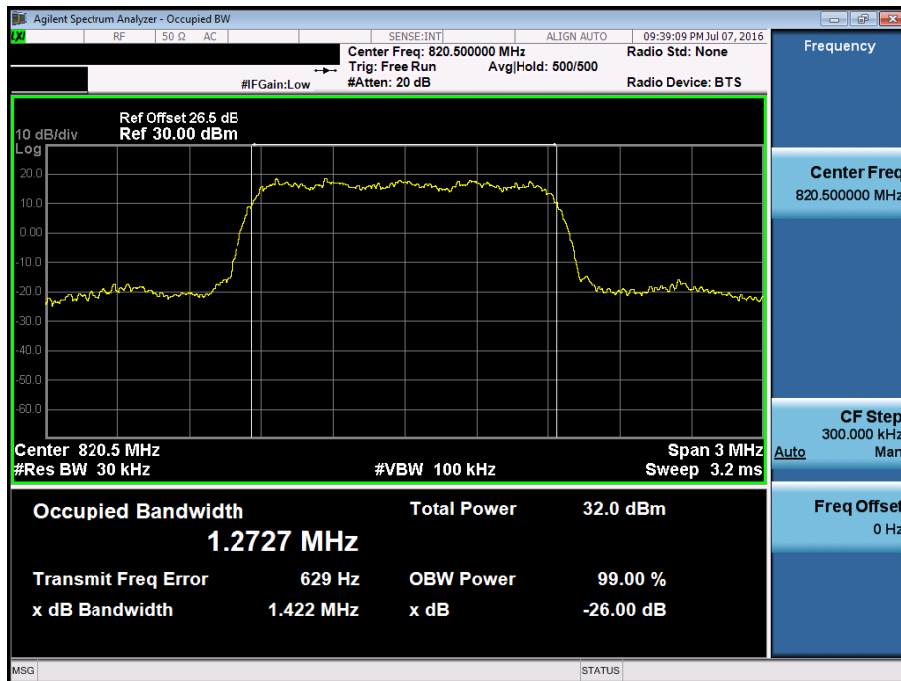

■ Secondary MODE (684 CH.) Occupied Bandwidth

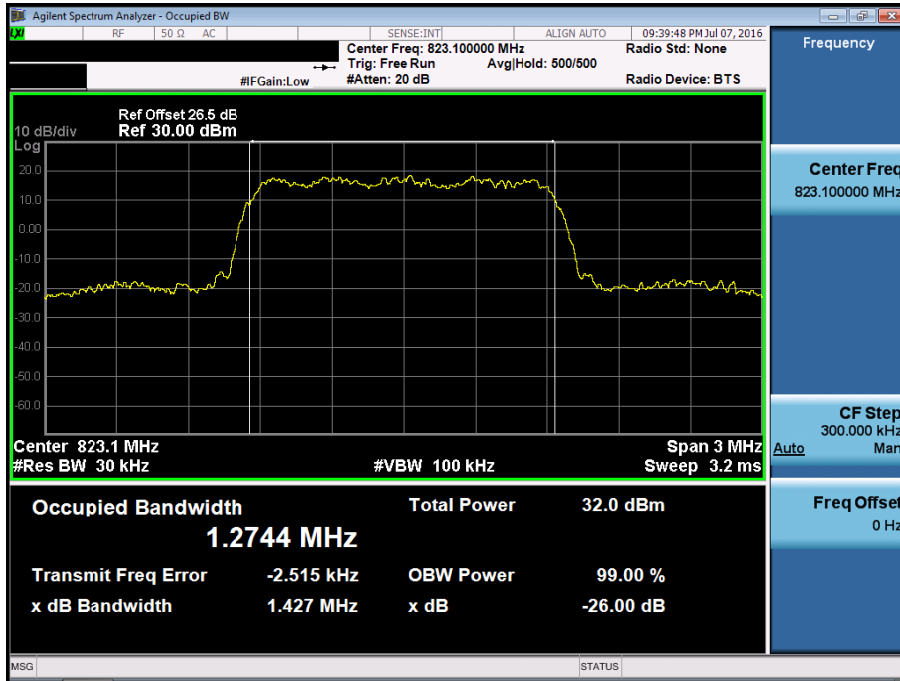

■ Secondary EVDO\_Rev.0MODE (476 CH.) Occupied Bandwidth

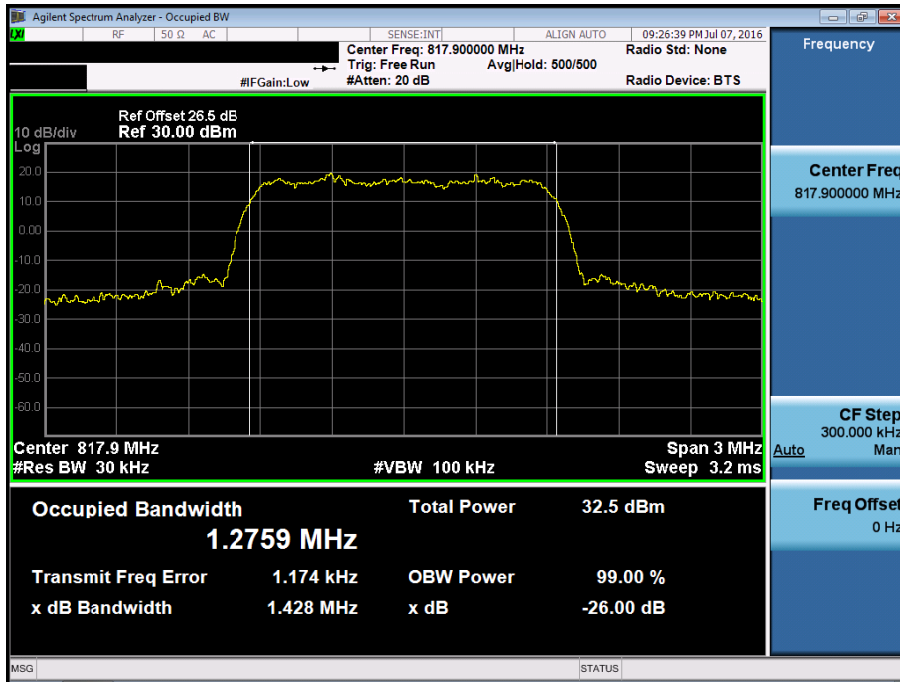

■ Secondary EVDO\_Rev.0MODE (580 CH.) Occupied Bandwidth

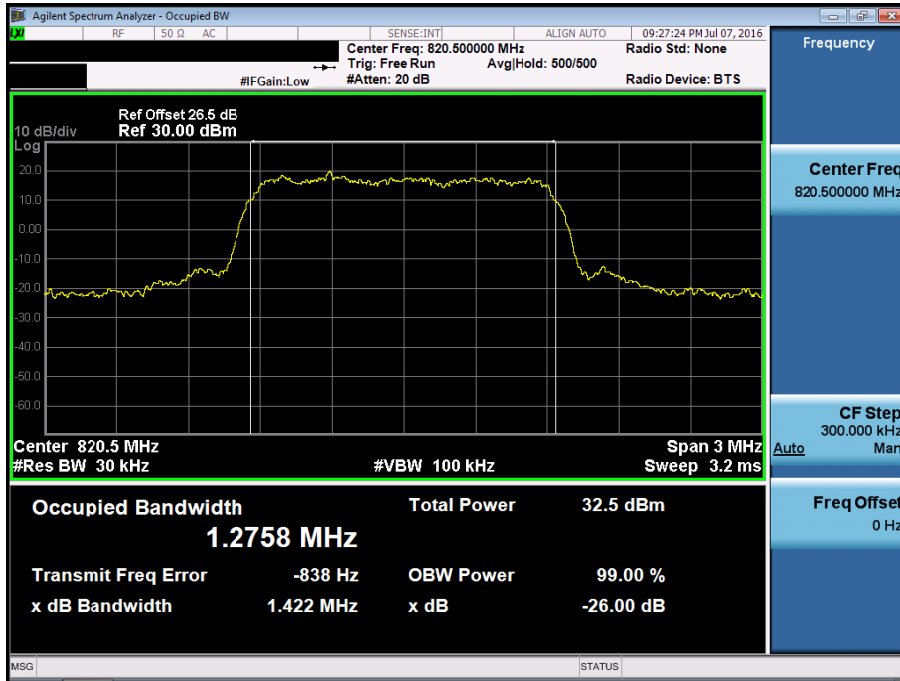

■ Secondary EVDO\_Rev.0MODE (684 CH.) Occupied Bandwidth

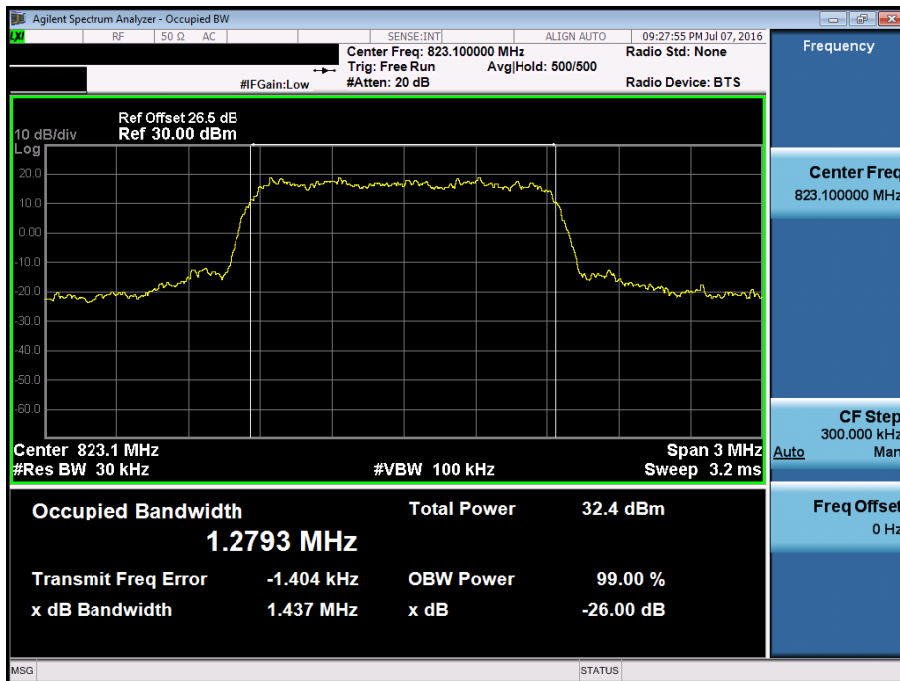

■ Secondary EVDO\_Rev.AMODE (476 CH.) Occupied Bandwidth

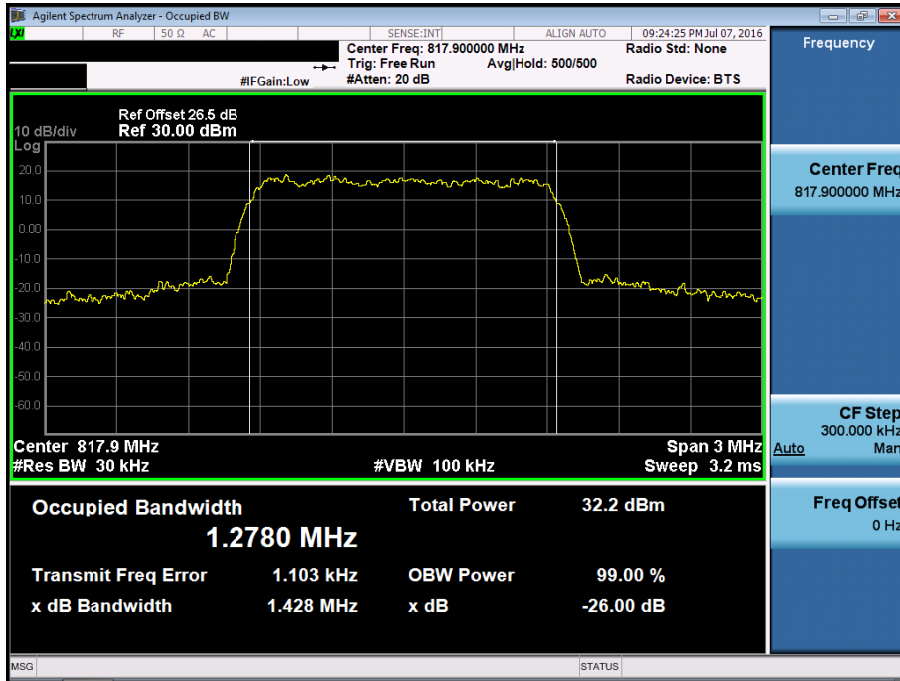

■ Secondary EVDO\_Rev.AMODE (580 CH.) Occupied Bandwidth

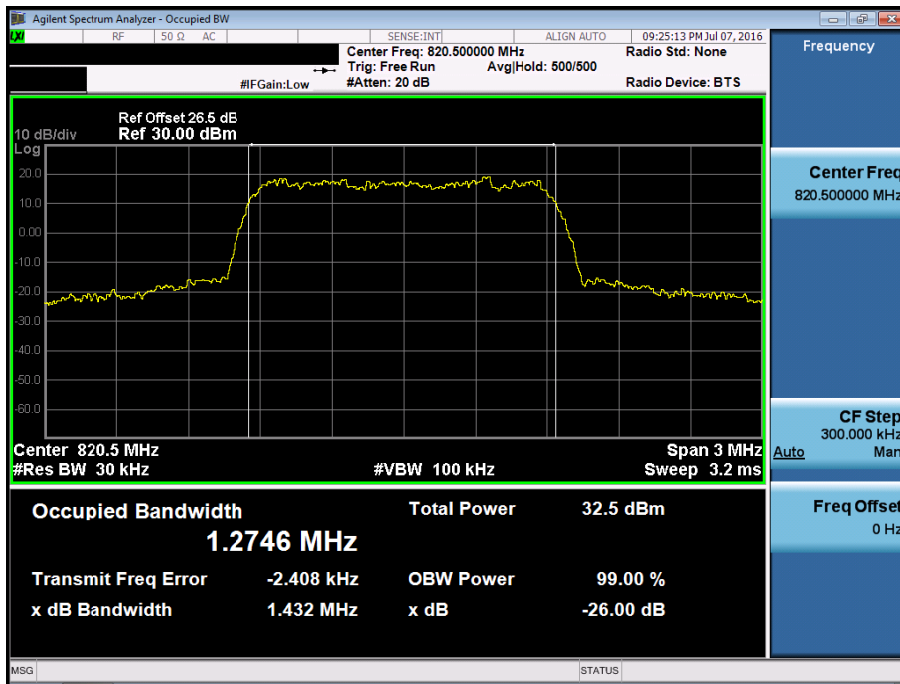

■ Secondary EVDO\_Rev.AMODE (684 CH.) Occupied Bandwidth

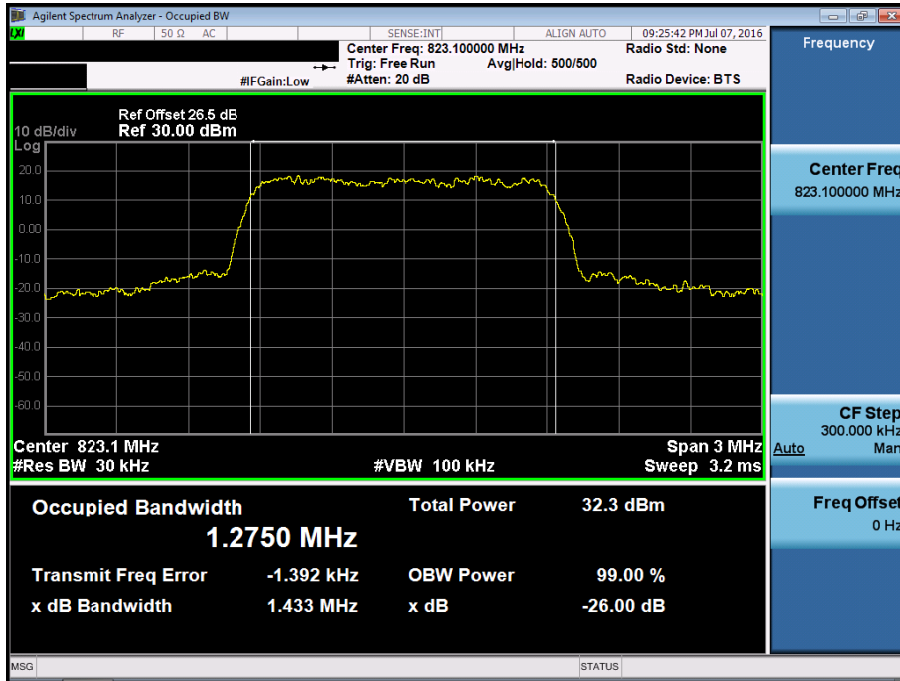

■ Secondary MODE (476 CH.) Block Edge





■ Secondary EVDO\_Rev.0 MODE (476 CH.) Block Edge

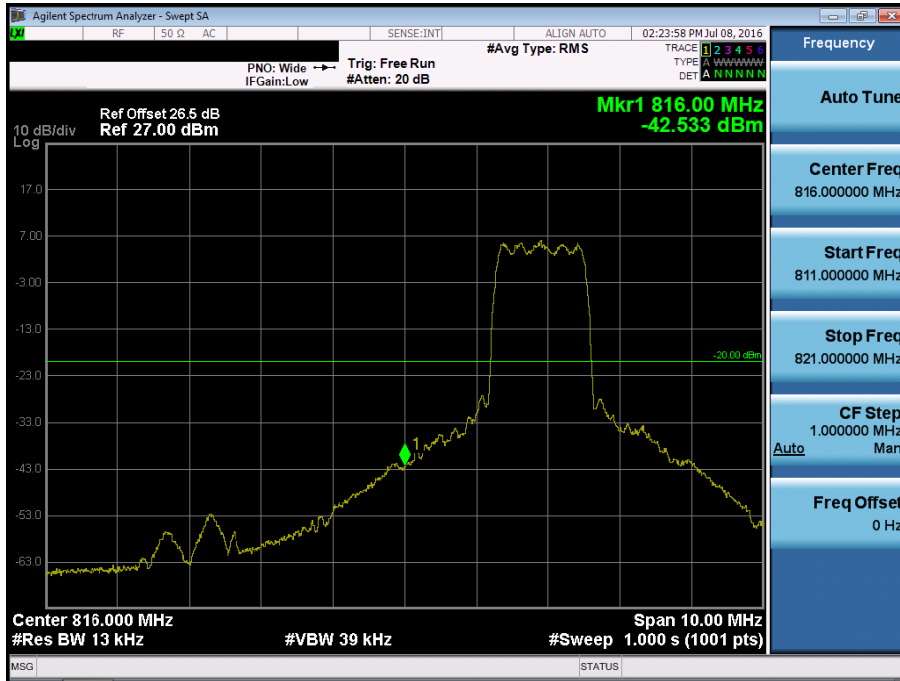

■ Secondary EVDO\_Rev.A MODE (476 CH.) Block Edge

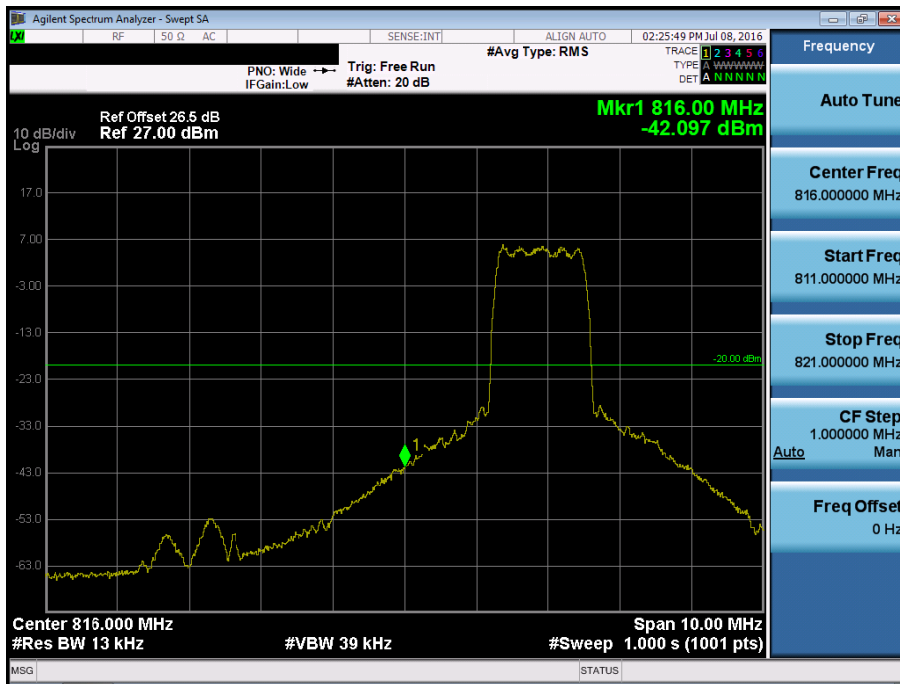

■ Secondary MODE (476 CH.) 4 MHz Span



■ Secondary EVDO\_Rev.0 MODE (476 CH.) 4 MHz Span

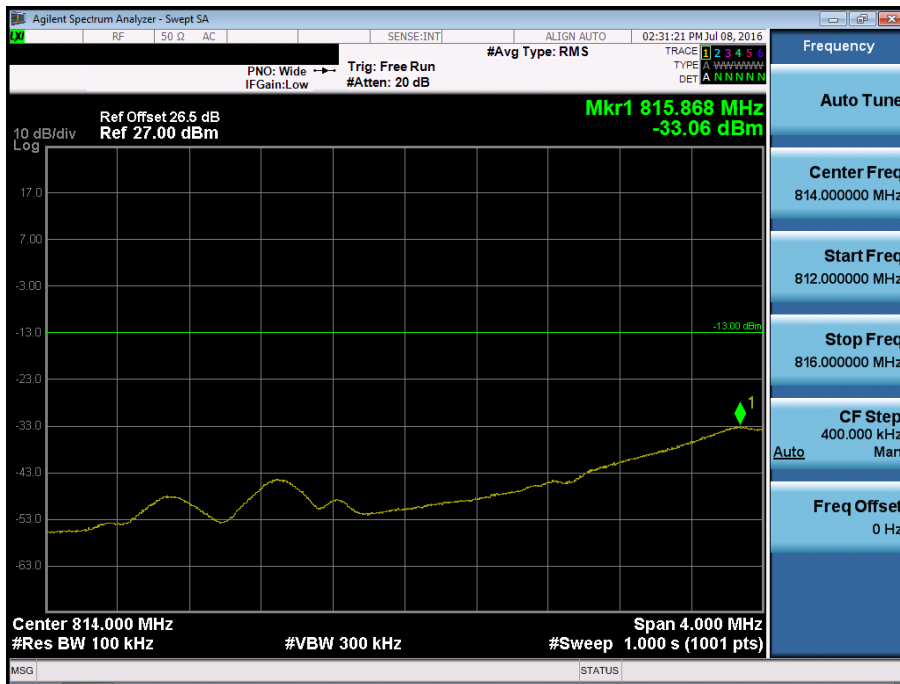

■ Secondary EVDO\_Rev.A MODE (476 CH.) 4 MHz Span



■ Secondary MODE (684 CH.) Block Edge

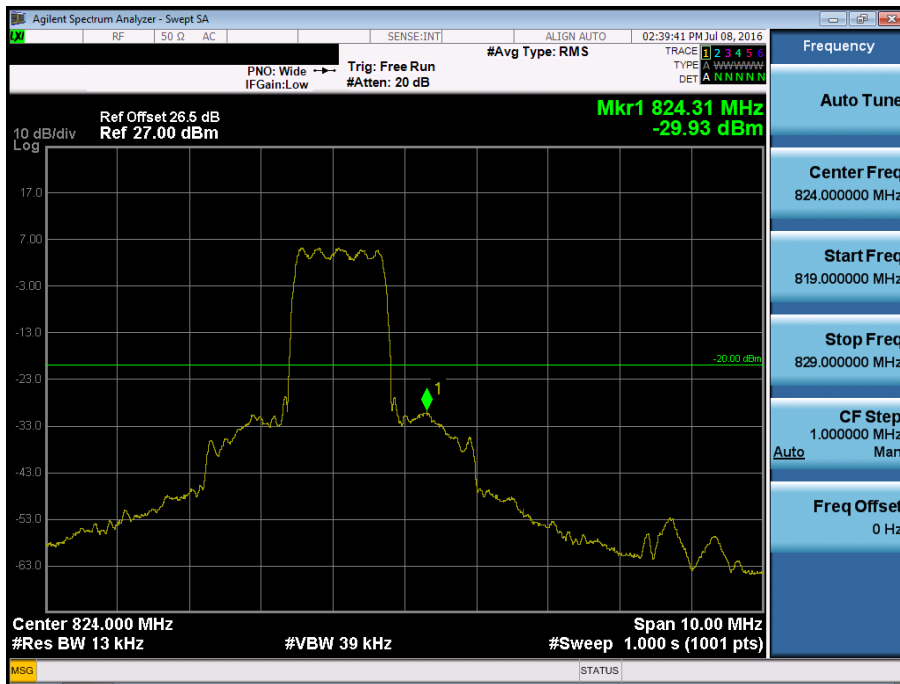

■ Secondary EVDO\_Rev.0 MODE (684 CH.) Block Edge

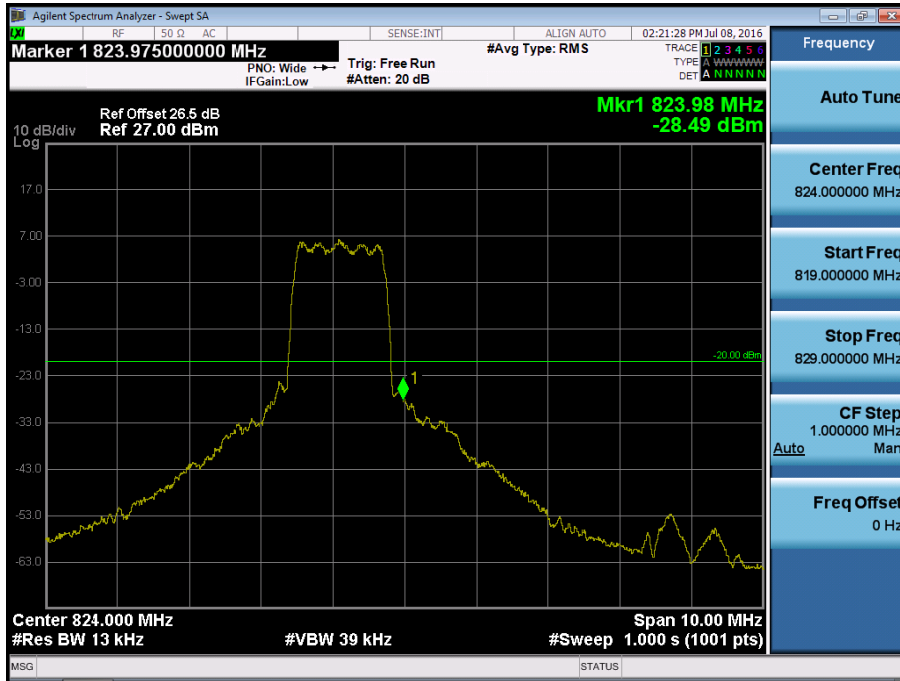

■ Secondary EVDO\_Rev.A MODE (684 CH.) Block Edge

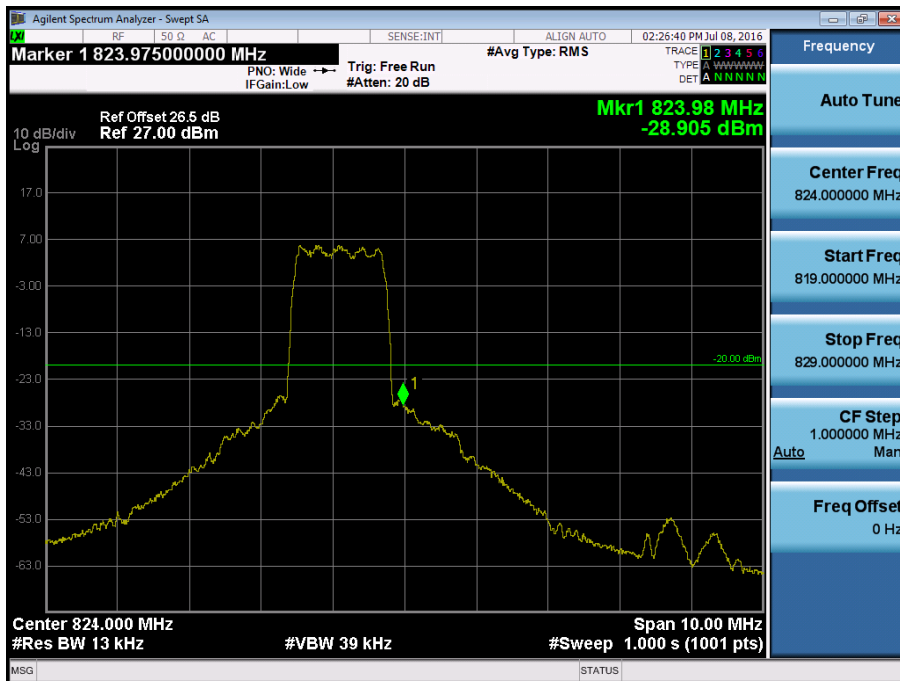

■ Secondary MODE (684 CH.) 4 MHz Span



■ Secondary EVDO\_Rev.0 MODE (684 CH.) 4 MHz Span





■ Secondary MODE (580 CH.) Conducted Spurious Emissions

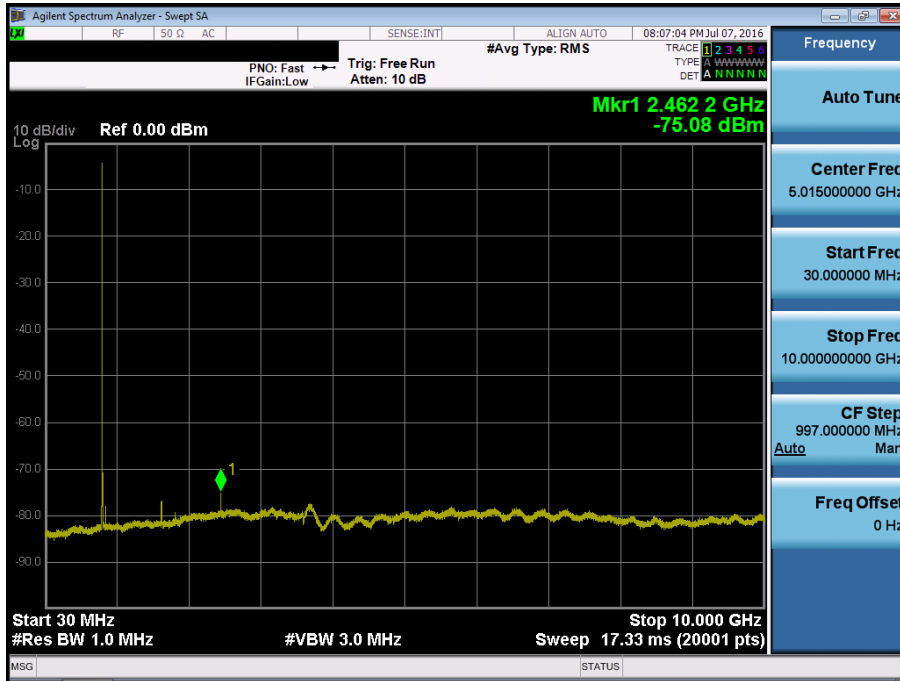

■ Secondary MODE (684 CH.) Conducted Spurious Emissions

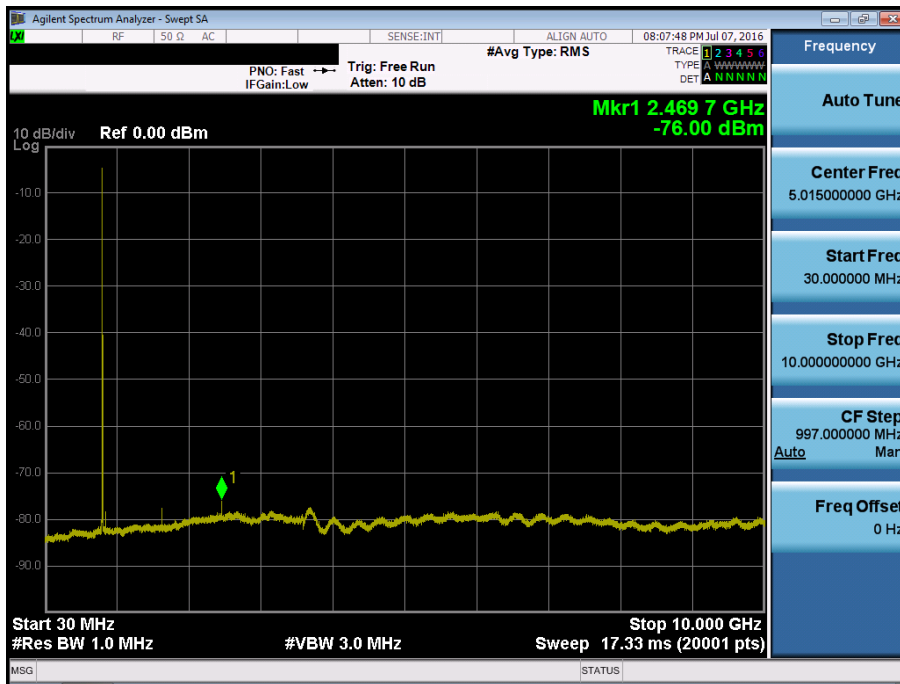

■ Secondary EVDO\_Rev.0MODE (476 CH.) Conducted Spurious Emissions

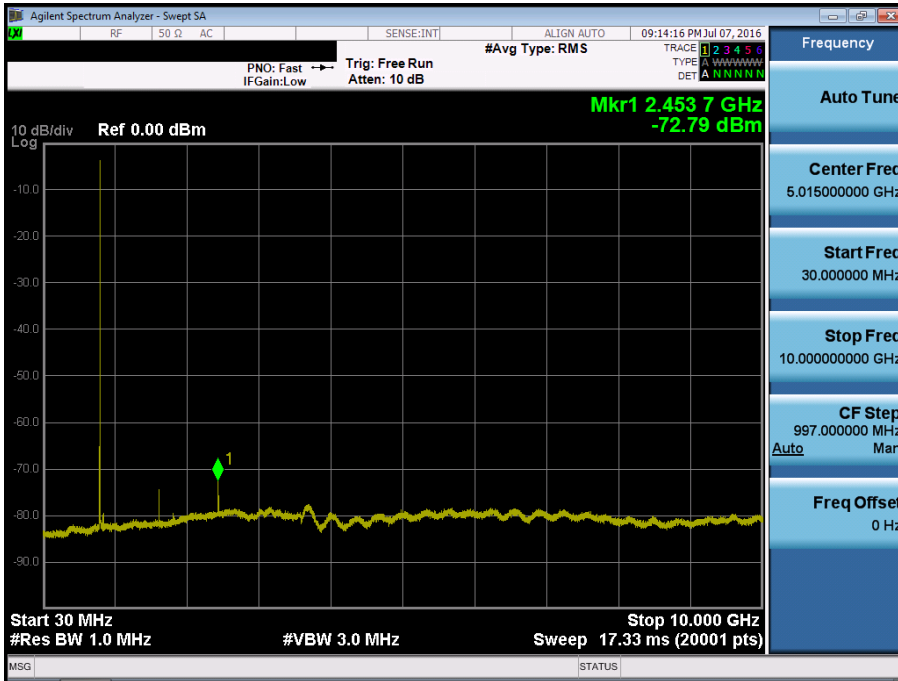

■ Secondary EVDO\_Rev.0 MODE (580 CH.) Conducted Spurious Emissions

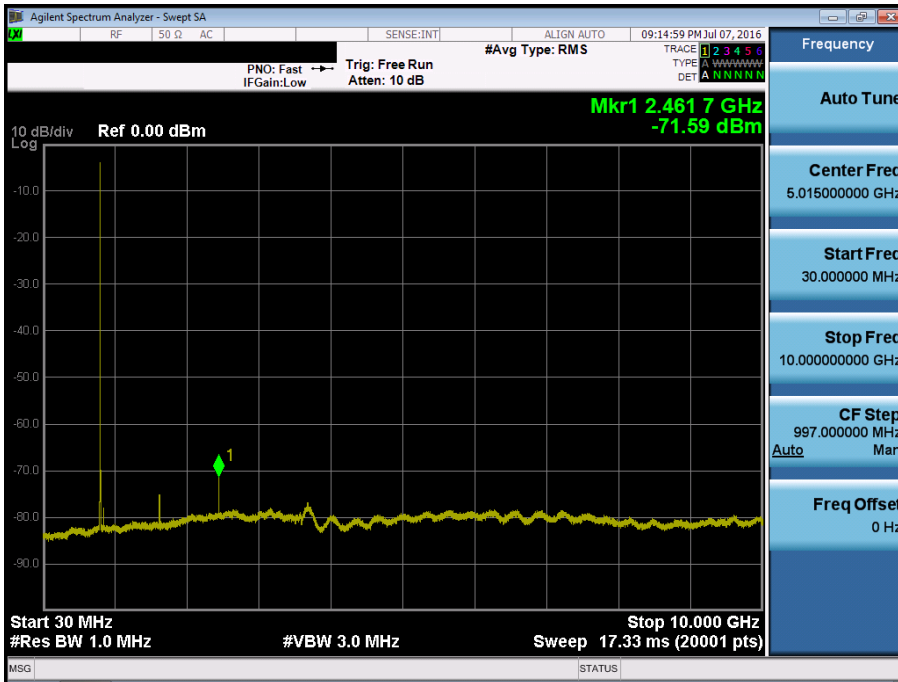



■ Secondary EVDO\_Rev.0 MODE (684 CH.) Conducted Spurious Emissions

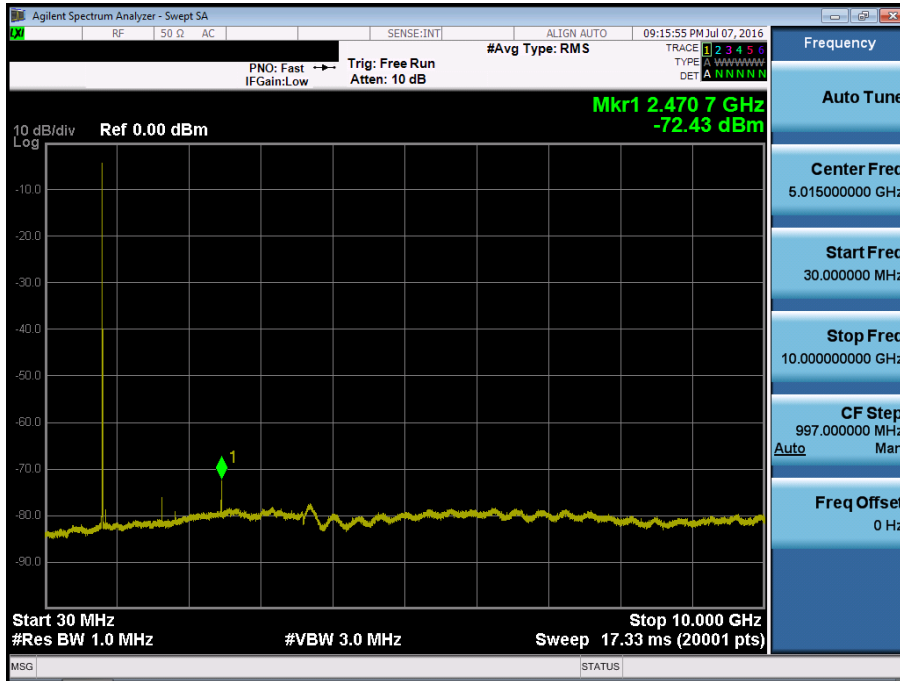

■ Secondary EVDO\_Rev.A MODE (476 CH.) Conducted Spurious Emissions

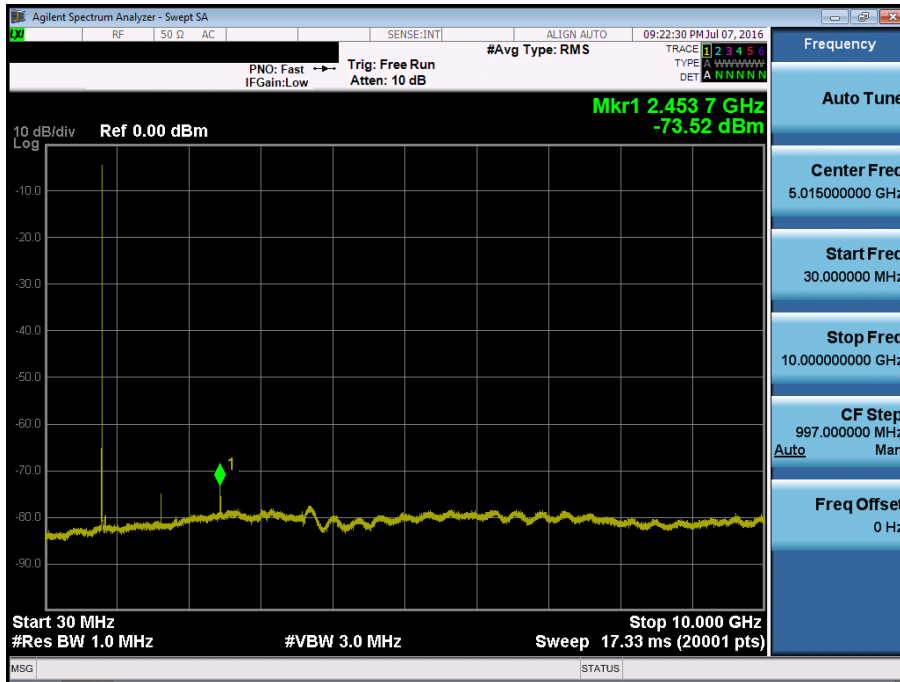

■ Secondary EVDO\_Rev.A MODE (580 CH.) Conducted Spurious Emissions

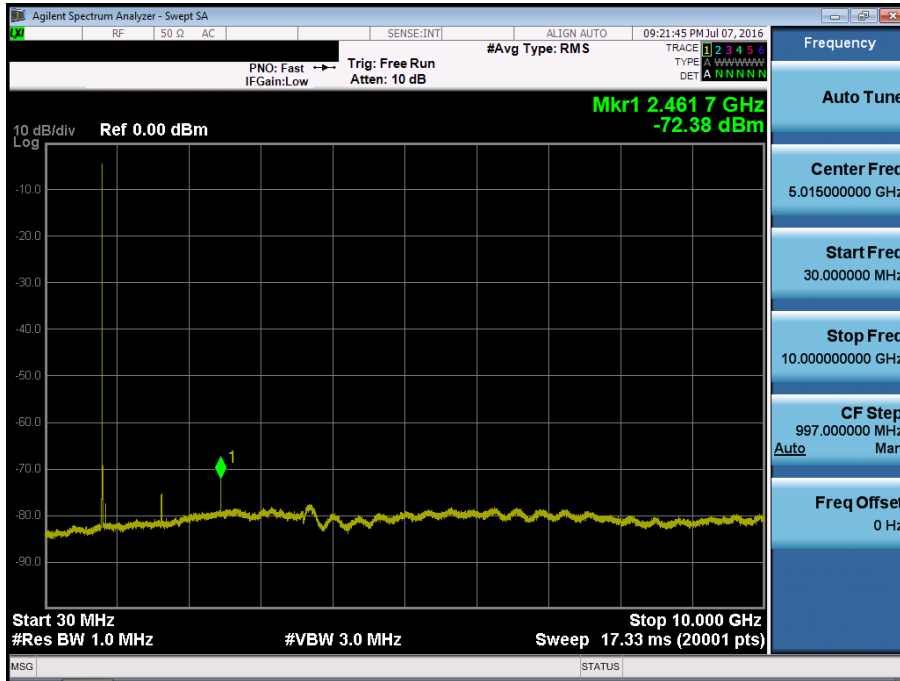

■ Secondary EVDO\_Rev.AMODE (684 CH.) Conducted Spurious Emissions

