

## Attachment 1. – SAR Test Plots

Test Laboratory: HCT CO., LTD  
EUT Type: USB Modem  
Liquid Temperature: 21.4 °C  
Ambient Temperature: 21.6 °C  
Test Date: Mar.26, 2010

**DUT: U600; Type: Bar; Serial: #1**

Communication System: WiMAX ; Frequency: 2593 MHz;Duty Cycle: 1:3.24  
Medium parameters used (interpolated):  $f = 2593$  MHz;  $\sigma = 2.17$  mho/m;  $\epsilon_r = 50.7$ ;  $\rho = 1000$  kg/m<sup>3</sup>  
Phantom section: Flat Section ; Measurement SW: DASY4, V4.7 Build 71; Postprocessing SW: SEMCAD, V1.8 Build 176

## DASY4 Configuration:

- Probe: ES3DV2 - SN3017; ConvF(3.78, 3.78, 3.78); Calibrated: 2009-07-22
- Sensor-Surface: 4mm (Mechanical Surface Detection)
- Electronics: DAE4 Sn869; Calibrated: 2009-09-18
- Phantom: SAM 1800/1900 MHz; Type: SAM

**WiMAX Body 2593/Area Scan (41x61x1):** Measurement grid: dx=15mm, dy=15mm

[Info: Interpolated medium parameters used for SAR evaluation.](#)

Maximum value of SAR (interpolated) = 0.286 mW/g

**WiMAX Body 2593/Zoom Scan (5x5x7)/Cube 0:** Measurement grid: dx=8mm, dy=8mm, dz=5mm

Reference Value = 8.16 V/m; Power Drift = -0.005 dB

Peak SAR (extrapolated) = 0.561 W/kg

**SAR(1 g) = 0.252 mW/g; SAR(10 g) = 0.119 mW/g**

[Info: Interpolated medium parameters used for SAR evaluation.](#)

Maximum value of SAR (measured) = 0.283 mW/g

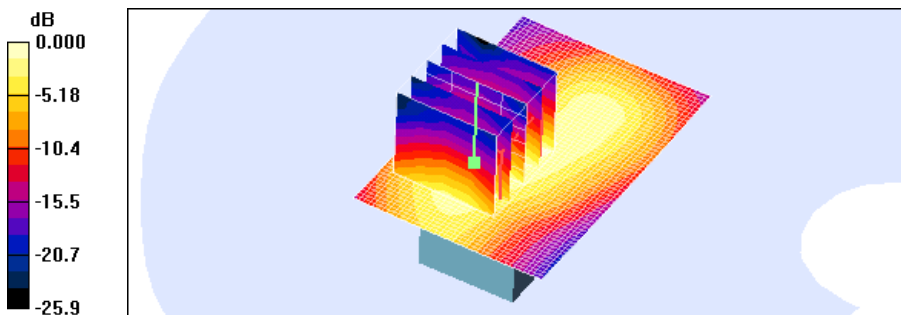

0 dB = 0.283mW/g

Test Laboratory: HCT CO., LTD  
EUT Type: USB Modem  
Liquid Temperature: 21.3 °C  
Ambient Temperature: 21.5 °C  
Test Date: May 5, 2010

**DUT: U600; Type: Bar; Serial: #1**

Communication System: WiMAX 2600MHz FCC; Frequency: 2498.5 MHz; Duty Cycle: 1:3.24  
Medium parameters used (interpolated):  $f = 2498.5$  MHz;  $\sigma = 2.06$  mho/m;  $\epsilon_r = 51.7$ ;  $\rho = 1000$  kg/m<sup>3</sup>  
Phantom section: Flat Section ; Measurement SW: DASY4, V4.7 Build 44; Postprocessing SW: SEMCAD, V1.8 Build 176

## DASY4 Configuration:

- Probe: ES3DV2 - SN3017; ConvF(3.78, 3.78, 3.78); Calibrated: 2009-07-22
- Sensor-Surface: 4mm (Mechanical Surface Detection)
- Electronics: DAE4 Sn869; Calibrated: 2009-09-18
- Phantom: SAM 1800/1900 MHz; Type: SAM

**WiMAX Body/Area Scan (41x61x1):** Measurement grid: dx=15mm, dy=15mm

Maximum value of SAR (interpolated) = 0.361 mW/g

**WiMAX Body/Zoom Scan (5x5x7)/Cube 0:** Measurement grid: dx=8mm, dy=8mm, dz=5mm

Reference Value = 11.8 V/m; Power Drift = -0.018 dB

Peak SAR (extrapolated) = 0.659 W/kg

**SAR(1 g) = 0.324 mW/g; SAR(10 g) = 0.162 mW/g**

Maximum value of SAR (measured) = 0.360 mW/g

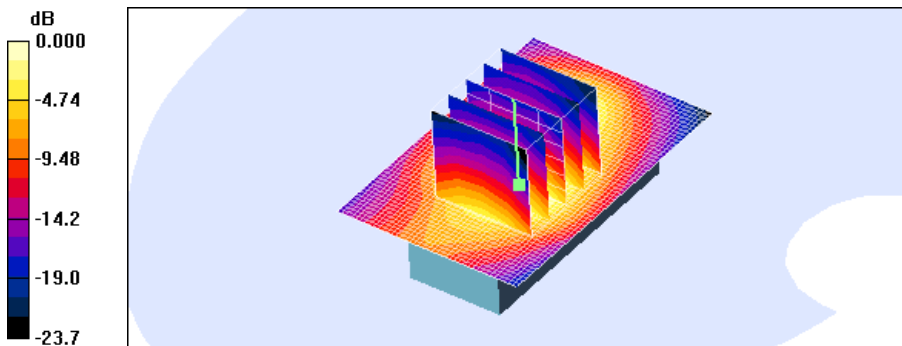

0 dB = 0.360mW/g

Test Laboratory: HCT CO., LTD  
EUT Type: USB Modem  
Liquid Temperature: 21.4 °C  
Ambient Temperature: 21.6 °C  
Test Date: Mar.26, 2010

**DUT: U600; Type: Bar; Serial: #1**

Communication System: WiMAX ; Frequency: 2593 MHz;Duty Cycle: 1:3.24  
Medium parameters used (interpolated):  $f = 2593$  MHz;  $\sigma = 2.17$  mho/m;  $\epsilon_r = 50.7$ ;  $\rho = 1000$  kg/m<sup>3</sup>  
Phantom section: Flat Section ; Measurement SW: DASY4, V4.7 Build 71; Postprocessing SW: SEMCAD, V1.8 Build 176

## DASY4 Configuration:

- Probe: ES3DV2 - SN3017; ConvF(3.78, 3.78, 3.78); Calibrated: 2009-07-22
- Sensor-Surface: 4mm (Mechanical Surface Detection)
- Electronics: DAE4 Sn869; Calibrated: 2009-09-18
- Phantom: SAM 1800/1900 MHz; Type: SAM

**WiMAX Body 2593/Area Scan (41x61x1):** Measurement grid: dx=15mm, dy=15mm

[Info: Interpolated medium parameters used for SAR evaluation.](#)

Maximum value of SAR (interpolated) = 0.721 mW/g

**WiMAX Body 2593/Zoom Scan (5x5x7)/Cube 0:** Measurement grid: dx=8mm, dy=8mm, dz=5mm

Reference Value = 14.2 V/m; Power Drift = 0.024 dB

Peak SAR (extrapolated) = 1.57 W/kg

**SAR(1 g) = 0.660 mW/g; SAR(10 g) = 0.281 mW/g**

[Info: Interpolated medium parameters used for SAR evaluation.](#)

Maximum value of SAR (measured) = 0.727 mW/g

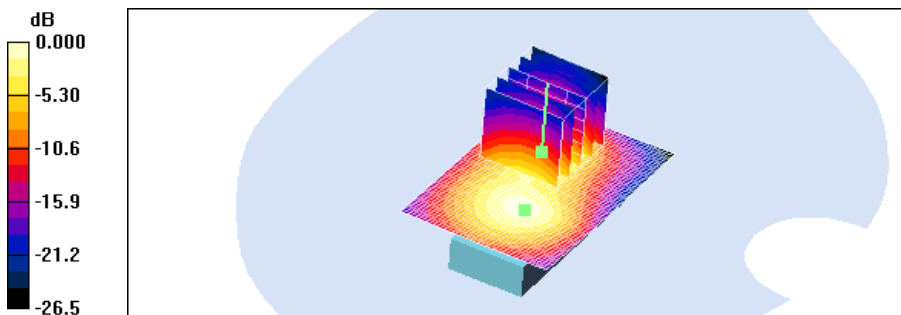

0 dB = 0.727mW/g

Test Laboratory: HCT CO., LTD  
EUT Type: USB Modem  
Liquid Temperature: 21.3 °C  
Ambient Temperature: 21.5 °C  
Test Date: May 5, 2010

**DUT: U600; Type: Bar; Serial: #1**

Communication System: WiMAX 2600MHz FCC; Frequency: 2687.5 MHz; Duty Cycle: 1:3.24  
Medium parameters used (interpolated):  $f = 2687.5$  MHz;  $\sigma = 2.26$  mho/m;  $\epsilon_r = 51.1$ ;  $\rho = 1000$  kg/m<sup>3</sup>  
Phantom section: Flat Section ; Measurement SW: DASY4, V4.7 Build 44; Postprocessing SW: SEMCAD, V1.8 Build 176

## DASY4 Configuration:

- Probe: ES3DV2 - SN3017; ConvF(3.78, 3.78, 3.78); Calibrated: 2009-07-22
- Sensor-Surface: 4mm (Mechanical Surface Detection)
- Electronics: DAE4 Sn869; Calibrated: 2009-09-18
- Phantom: SAM 1800/1900 MHz; Type: SAM

**WiMAX Body/Area Scan (41x61x1):** Measurement grid: dx=15mm, dy=15mm

**Info:** Interpolated medium parameters used for SAR evaluation.

Maximum value of SAR (interpolated) = 0.331 mW/g

**WiMAX Body/Zoom Scan (5x5x7)/Cube 0:** Measurement grid: dx=8mm, dy=8mm, dz=5mm

Reference Value = 12.1 V/m; Power Drift = -0.010 dB

Peak SAR (extrapolated) = 0.916 W/kg

**SAR(1 g) = 0.338 mW/g; SAR(10 g) = 0.145 mW/g**

Maximum value of SAR (measured) = 0.344 mW/g

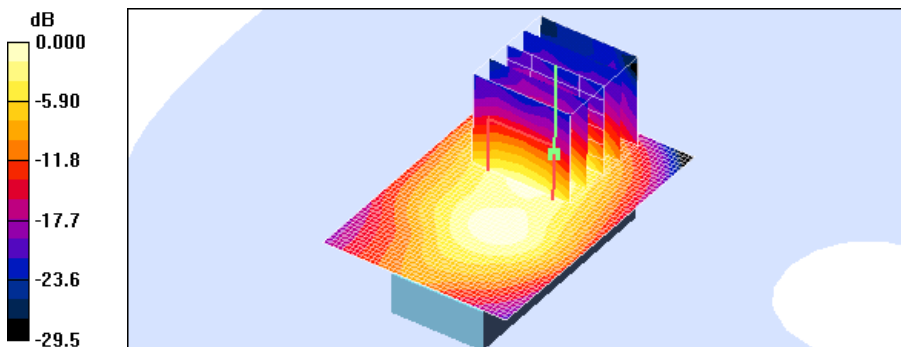

Test Laboratory: HCT CO., LTD  
EUT Type: USB Modem  
Liquid Temperature: 21.4 °C  
Ambient Temperature: 21.6 °C  
Test Date: Mar.26, 2010

**DUT: U600; Type: side; Serial: #1**

Communication System: WiMAX ; Frequency: 2593 MHz;Duty Cycle: 1:3.24  
Medium parameters used (interpolated):  $f = 2593$  MHz;  $\sigma = 2.17$  mho/m;  $\epsilon_r = 50.7$ ;  $\rho = 1000$  kg/m<sup>3</sup>  
Phantom section: Flat Section ; Measurement SW: DASY4, V4.7 Build 71; Postprocessing SW: SEMCAD, V1.8 Build 176

DASY4 Configuration:

- Probe: ES3DV2 - SN3017; ConvF(3.78, 3.78, 3.78); Calibrated: 2009-07-22
- Sensor-Surface: 4mm (Mechanical Surface Detection)
- Electronics: DAE4 Sn869; Calibrated: 2009-09-18
- Phantom: SAM 1800/1900 MHz; Type: SAM

**Wimax Body 2593/Area Scan (41x71x1):** Measurement grid: dx=15mm, dy=15mm

[Info: Interpolated medium parameters used for SAR evaluation.](#)

Maximum value of SAR (interpolated) = 0.394 mW/g

**Wimax Body 2593/Zoom Scan (5x5x7)/Cube 0:** Measurement grid: dx=8mm, dy=8mm, dz=5mm

Reference Value = 10.2 V/m; Power Drift = 0.054 dB

Peak SAR (extrapolated) = 0.813 W/kg

**SAR(1 g) = 0.356 mW/g; SAR(10 g) = 0.160 mW/g**

[Info: Interpolated medium parameters used for SAR evaluation.](#)

Maximum value of SAR (measured) = 0.403 mW/g

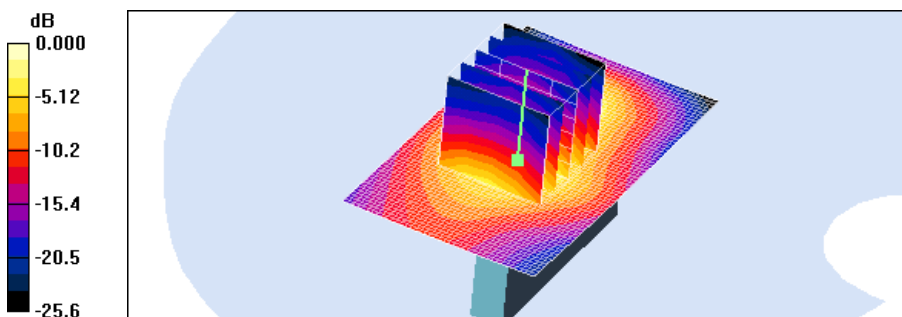

0 dB = 0.403mW/g

Test Laboratory: HCT CO., LTD  
EUT Type: USB Modem  
Liquid Temperature: 21.4 °C  
Ambient Temperature: 21.6 °C  
Test Date: Mar.26, 2010

**DUT: U600; Type: side; Serial: #1**

Communication System: WiMAX ; Frequency: 2593 MHz;Duty Cycle: 1:3.24  
Medium parameters used (interpolated):  $f = 2593$  MHz;  $\sigma = 2.17$  mho/m;  $\epsilon_r = 50.7$ ;  $\rho = 1000$  kg/m<sup>3</sup>  
Phantom section: Flat Section ; Measurement SW: DASY4, V4.7 Build 71; Postprocessing SW: SEMCAD, V1.8 Build 176

DASY4 Configuration:

- Probe: ES3DV2 - SN3017; ConvF(3.78, 3.78, 3.78); Calibrated: 2009-07-22
- Sensor-Surface: 4mm (Mechanical Surface Detection)
- Electronics: DAE4 Sn869; Calibrated: 2009-09-18
- Phantom: SAM 1800/1900 MHz; Type: SAM

**Wimax Body 2593/Area Scan (41x71x1):** Measurement grid: dx=15mm, dy=15mm

[Info: Interpolated medium parameters used for SAR evaluation.](#)

Maximum value of SAR (interpolated) = 0.156 mW/g

**Wimax Body 2593/Zoom Scan (5x5x7)/Cube 0:** Measurement grid: dx=8mm, dy=8mm, dz=5mm

Reference Value = 4.27 V/m; Power Drift = 0.018 dB

Peak SAR (extrapolated) = 0.298 W/kg

**SAR(1 g) = 0.136 mW/g; SAR(10 g) = 0.063 mW/g**

[Info: Interpolated medium parameters used for SAR evaluation.](#)

Maximum value of SAR (measured) = 0.150 mW/g

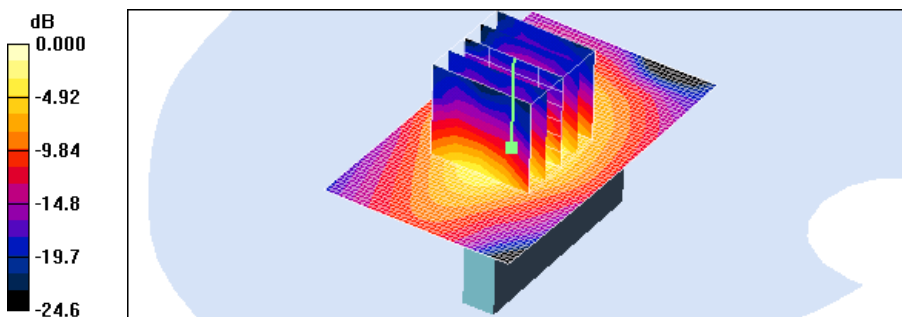

Test Laboratory: HCT CO., LTD  
EUT Type: USB Modem  
Liquid Temperature: 21.4 °C  
Ambient Temperature: 21.6 °C  
Test Date: Mar.26, 2010

**DUT: U600; Type: Bar; Serial: #1**

Communication System: WiMAX ; Frequency: 2593 MHz;Duty Cycle: 1:3.24  
Medium parameters used (interpolated):  $f = 2593$  MHz;  $\sigma = 2.17$  mho/m;  $\epsilon_r = 50.7$ ;  $\rho = 1000$  kg/m<sup>3</sup>  
Phantom section: Flat Section ; Measurement SW: DASY4, V4.7 Build 71; Postprocessing SW: SEMCAD, V1.8 Build 176

## DASY4 Configuration:

- Probe: ES3DV2 - SN3017; ConvF(3.78, 3.78, 3.78); Calibrated: 2009-07-22
- Sensor-Surface: 4mm (Mechanical Surface Detection)
- Electronics: DAE4 Sn869; Calibrated: 2009-09-18
- Phantom: SAM 1800/1900 MHz; Type: SAM

**Wimax Body 2593/Area Scan (51x51x1):** Measurement grid: dx=15mm, dy=15mm

[Info: Interpolated medium parameters used for SAR evaluation.](#)

Maximum value of SAR (interpolated) = 0.044 mW/g

**Wimax Body 2593/Zoom Scan (5x5x7)/Cube 0:** Measurement grid: dx=8mm, dy=8mm, dz=5mm

Reference Value = 4.00 V/m; Power Drift = -0.031 dB

Peak SAR (extrapolated) = 0.090 W/kg

**SAR(1 g) = 0.041 mW/g; SAR(10 g) = 0.019 mW/g**

[Info: Interpolated medium parameters used for SAR evaluation.](#)

Maximum value of SAR (measured) = 0.043 mW/g

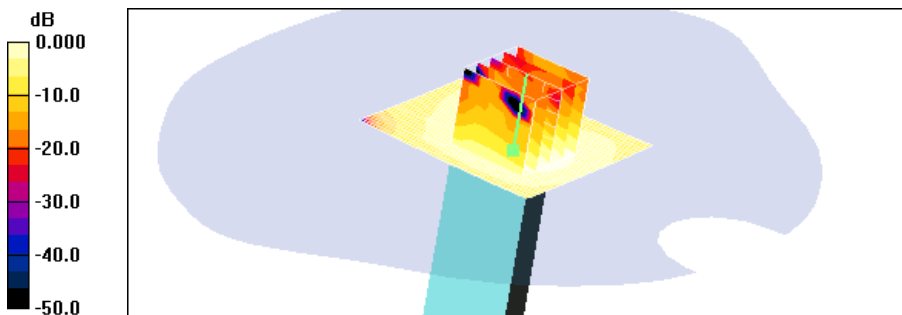

0 dB = 0.043mW/g



Test Laboratory: HCT CO., LTD  
EUT Type: USB Modem  
Liquid Temperature: 21.4 °C  
Ambient Temperature: 21.6 °C  
Test Date: Mar.26, 2010

**DUT: U600; Type: Bar; Serial: #1**

Communication System: WiMAX ; Frequency: 2593 MHz;Duty Cycle: 1:3.24  
Medium parameters used (interpolated):  $f = 2593$  MHz;  $\sigma = 2.17$  mho/m;  $\epsilon_r = 50.7$ ;  $\rho = 1000$  kg/m<sup>3</sup>  
Phantom section: Flat Section ; Measurement SW: DASY4, V4.7 Build 71; Postprocessing SW: SEMCAD, V1.8 Build 176

## DASY4 Configuration:

- Probe: ES3DV2 - SN3017; ConvF(3.78, 3.78, 3.78); Calibrated: 2009-07-22
- Sensor-Surface: 4mm (Mechanical Surface Detection)
- Electronics: DAE4 Sn869; Calibrated: 2009-09-18
- Phantom: SAM 1800/1900 MHz; Type: SAM

**WiMAX Body 2593/Area Scan (41x61x1):** Measurement grid: dx=15mm, dy=15mm

[Info: Interpolated medium parameters used for SAR evaluation.](#)

Maximum value of SAR (interpolated) = 0.275 mW/g

**WiMAX Body 2593/Zoom Scan (5x5x7)/Cube 0:** Measurement grid: dx=8mm, dy=8mm, dz=5mm

Reference Value = 7.93 V/m; Power Drift = -0.058 dB

Peak SAR (extrapolated) = 0.513 W/kg

**SAR(1 g) = 0.239 mW/g; SAR(10 g) = 0.114 mW/g**

[Info: Interpolated medium parameters used for SAR evaluation.](#)

Maximum value of SAR (measured) = 0.266 mW/g

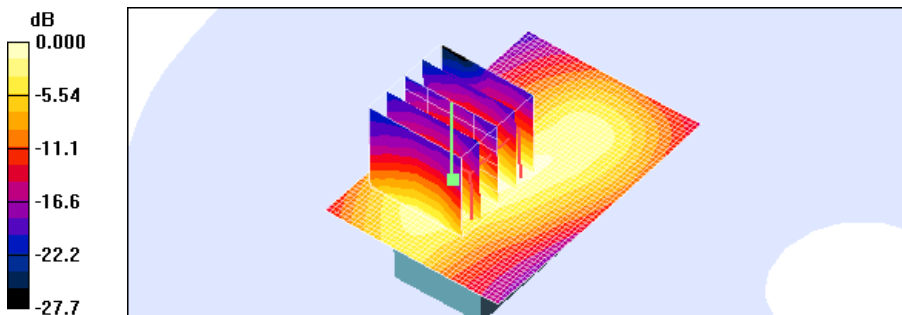

0 dB = 0.266mW/g

Test Laboratory: HCT CO., LTD  
EUT Type: USB Modem  
Liquid Temperature: 21.3 °C  
Ambient Temperature: 21.5 °C  
Test Date: May 5, 2010

**DUT: U600; Type: Bar; Serial: #1**

Communication System: WiMAX 2600MHz FCC; Frequency: 2498.5 MHz; Duty Cycle: 1:3.24  
Medium parameters used (interpolated):  $f = 2498.5$  MHz;  $\sigma = 2.06$  mho/m;  $\epsilon_r = 51.7$ ;  $\rho = 1000$  kg/m<sup>3</sup>  
Phantom section: Flat Section ; Measurement SW: DASY4, V4.7 Build 44; Postprocessing SW: SEMCAD, V1.8 Build 176

## DASY4 Configuration:

- Probe: ES3DV2 - SN3017; ConvF(3.78, 3.78, 3.78); Calibrated: 2009-07-22
- Sensor-Surface: 4mm (Mechanical Surface Detection)
- Electronics: DAE4 Sn869; Calibrated: 2009-09-18
- Phantom: SAM 1800/1900 MHz; Type: SAM

**WiMAX Body/Area Scan (41x61x1):** Measurement grid: dx=15mm, dy=15mm

Maximum value of SAR (interpolated) = 0.318 mW/g

**WiMAX Body/Zoom Scan (5x5x7)/Cube 0:** Measurement grid: dx=8mm, dy=8mm, dz=5mm

Reference Value = 11.6 V/m; Power Drift = 0.021 dB

Peak SAR (extrapolated) = 0.590 W/kg

**SAR(1 g) = 0.289 mW/g; SAR(10 g) = 0.145 mW/g**

Maximum value of SAR (measured) = 0.319 mW/g

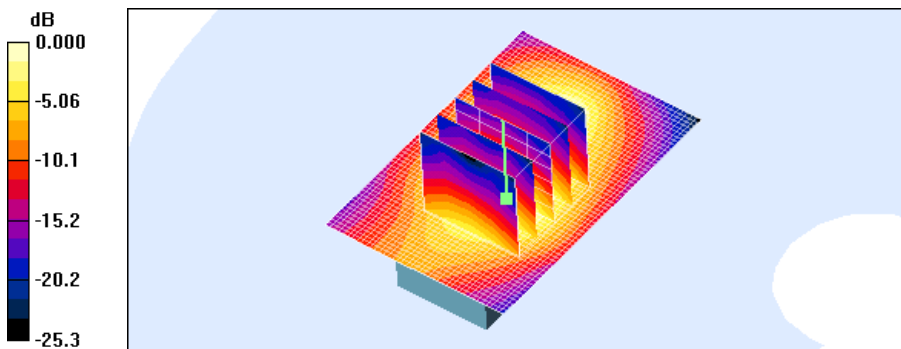

0 dB = 0.319mW/g

Test Laboratory: HCT CO., LTD  
EUT Type: USB Modem  
Liquid Temperature: 21.4 °C  
Ambient Temperature: 21.6 °C  
Test Date: Mar.26, 2010

**DUT: U600; Type: Bar; Serial: #1**

Communication System: WiMAX ; Frequency: 2593 MHz;Duty Cycle: 1:3.24  
Medium parameters used (interpolated):  $f = 2593$  MHz;  $\sigma = 2.17$  mho/m;  $\epsilon_r = 50.7$ ;  $\rho = 1000$  kg/m<sup>3</sup>  
Phantom section: Flat Section ; Measurement SW: DASY4, V4.7 Build 71; Postprocessing SW: SEMCAD, V1.8 Build 176

## DASY4 Configuration:

- Probe: ES3DV2 - SN3017; ConvF(3.78, 3.78, 3.78); Calibrated: 2009-07-22
- Sensor-Surface: 4mm (Mechanical Surface Detection)
- Electronics: DAE4 Sn869; Calibrated: 2009-09-18
- Phantom: SAM 1800/1900 MHz; Type: SAM

**WiMAX Body 2593/Area Scan (41x61x1):** Measurement grid: dx=15mm, dy=15mm

[Info: Interpolated medium parameters used for SAR evaluation.](#)

Maximum value of SAR (interpolated) = 0.718 mW/g

**WiMAX Body 2593/Zoom Scan (5x5x7)/Cube 0:** Measurement grid: dx=8mm, dy=8mm, dz=5mm

Reference Value = 14.4 V/m; Power Drift = -0.019 dB

Peak SAR (extrapolated) = 1.57 W/kg

**SAR(1 g) = 0.657 mW/g; SAR(10 g) = 0.279 mW/g**

[Info: Interpolated medium parameters used for SAR evaluation.](#)

Maximum value of SAR (measured) = 0.719 mW/g

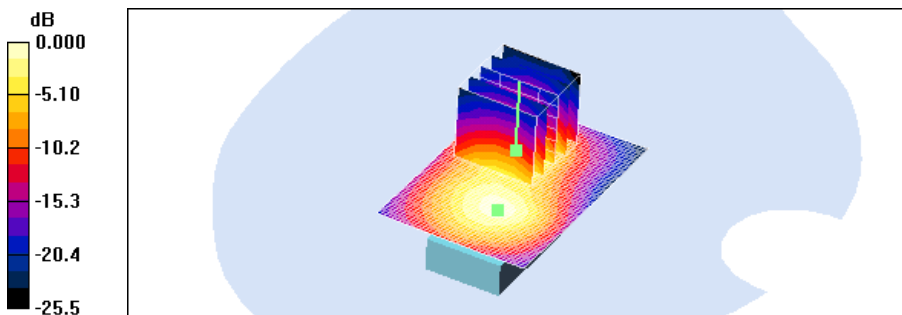

0 dB = 0.719mW/g

Test Laboratory: HCT CO., LTD  
EUT Type: USB Modem  
Liquid Temperature: 21.3 °C  
Ambient Temperature: 21.5 °C  
Test Date: May.05, 2010

**DUT: U600; Type: Bar; Serial: #1**

Communication System: WiMAX 2600MHz FCC; Frequency: 2687.5 MHz; Duty Cycle: 1:3.24  
Medium parameters used (interpolated):  $f = 2687.5$  MHz;  $\sigma = 2.26$  mho/m;  $\epsilon_r = 51.1$ ;  $\rho = 1000$  kg/m<sup>3</sup>  
Phantom section: Flat Section ; Measurement SW: DASY4, V4.7 Build 44; Postprocessing SW: SEMCAD, V1.8 Build 176

## DASY4 Configuration:

- Probe: ES3DV2 - SN3017; ConvF(3.78, 3.78, 3.78); Calibrated: 2009-07-22
- Sensor-Surface: 4mm (Mechanical Surface Detection)
- Electronics: DAE4 Sn869; Calibrated: 2009-09-18
- Phantom: SAM 1800/1900 MHz; Type: SAM

**WiMAX Body/Area Scan (41x61x1):** Measurement grid: dx=15mm, dy=15mm

[Info: Interpolated medium parameters used for SAR evaluation.](#)

Maximum value of SAR (interpolated) = 0.357 mW/g

**WiMAX Body/Zoom Scan (5x5x7)/Cube 0:** Measurement grid: dx=8mm, dy=8mm, dz=5mm

Reference Value = 12.1 V/m; Power Drift = 0.093 dB

Peak SAR (extrapolated) = 0.914 W/kg

**SAR(1 g) = 0.339 mW/g; SAR(10 g) = 0.145 mW/g**

Maximum value of SAR (measured) = 0.345 mW/g

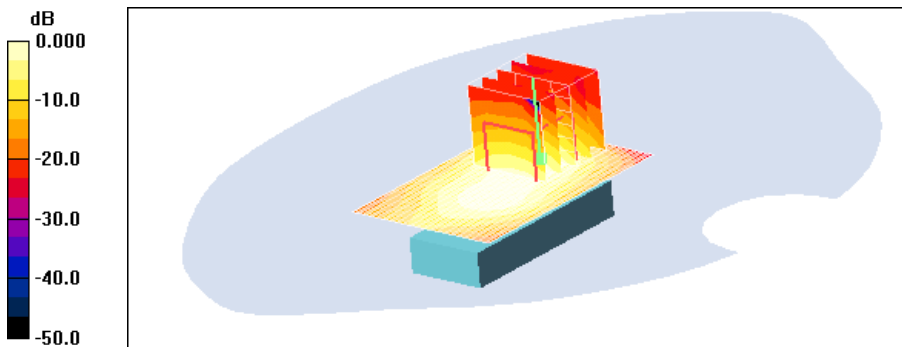

0 dB = 0.345mW/g

Test Laboratory: HCT CO., LTD  
EUT Type: USB Modem  
Liquid Temperature: 21.4 °C  
Ambient Temperature: 21.6 °C  
Test Date: Mar.26, 2010

**DUT: U600; Type: side; Serial: #1**

Communication System: WiMAX ; Frequency: 2593 MHz;Duty Cycle: 1:3.24  
Medium parameters used (interpolated):  $f = 2593$  MHz;  $\sigma = 2.17$  mho/m;  $\epsilon_r = 50.7$ ;  $\rho = 1000$  kg/m<sup>3</sup>  
Phantom section: Flat Section ; Measurement SW: DASY4, V4.7 Build 71; Postprocessing SW: SEMCAD, V1.8 Build 176

DASY4 Configuration:

- Probe: ES3DV2 - SN3017; ConvF(3.78, 3.78, 3.78); Calibrated: 2009-07-22
- Sensor-Surface: 4mm (Mechanical Surface Detection)
- Electronics: DAE4 Sn869; Calibrated: 2009-09-18
- Phantom: SAM 1800/1900 MHz; Type: SAM

**Wimax Body 2593/Area Scan (41x71x1):** Measurement grid: dx=15mm, dy=15mm

[Info: Interpolated medium parameters used for SAR evaluation.](#)

Maximum value of SAR (interpolated) = 0.386 mW/g

**Wimax Body 2593/Zoom Scan (5x5x7)/Cube 0:** Measurement grid: dx=8mm, dy=8mm, dz=5mm

Reference Value = 9.86 V/m; Power Drift = 0.142 dB

Peak SAR (extrapolated) = 0.793 W/kg

**SAR(1 g) = 0.339 mW/g; SAR(10 g) = 0.153 mW/g**

[Info: Interpolated medium parameters used for SAR evaluation.](#)

Maximum value of SAR (measured) = 0.387 mW/g

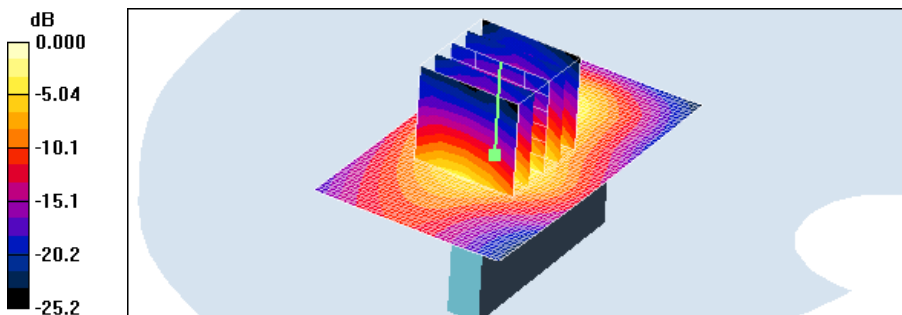

0 dB = 0.387mW/g

Test Laboratory: HCT CO., LTD  
EUT Type: USB Modem  
Liquid Temperature: 21.4 °C  
Ambient Temperature: 21.6 °C  
Test Date: Mar.26, 2010

**DUT: U600; Type: side; Serial: #1**

Communication System: WiMAX ; Frequency: 2593 MHz;Duty Cycle: 1:3.24  
Medium parameters used (interpolated):  $f = 2593$  MHz;  $\sigma = 2.17$  mho/m;  $\epsilon_r = 50.7$ ;  $\rho = 1000$  kg/m<sup>3</sup>  
Phantom section: Flat Section ; Measurement SW: DASY4, V4.7 Build 71; Postprocessing SW: SEMCAD, V1.8 Build 176

DASY4 Configuration:

- Probe: ES3DV2 - SN3017; ConvF(3.78, 3.78, 3.78); Calibrated: 2009-07-22
- Sensor-Surface: 4mm (Mechanical Surface Detection)
- Electronics: DAE4 Sn869; Calibrated: 2009-09-18
- Phantom: SAM 1800/1900 MHz; Type: SAM

**Wimax Body 2593/Area Scan (41x71x1):** Measurement grid: dx=15mm, dy=15mm

[Info: Interpolated medium parameters used for SAR evaluation.](#)

Maximum value of SAR (interpolated) = 0.164 mW/g

**Wimax Body 2593/Zoom Scan (5x5x7)/Cube 0:** Measurement grid: dx=8mm, dy=8mm, dz=5mm

Reference Value = 4.38 V/m; Power Drift = -0.151 dB

Peak SAR (extrapolated) = 0.316 W/kg

**SAR(1 g) = 0.141 mW/g; SAR(10 g) = 0.065 mW/g**

[Info: Interpolated medium parameters used for SAR evaluation.](#)

Maximum value of SAR (measured) = 0.156 mW/g

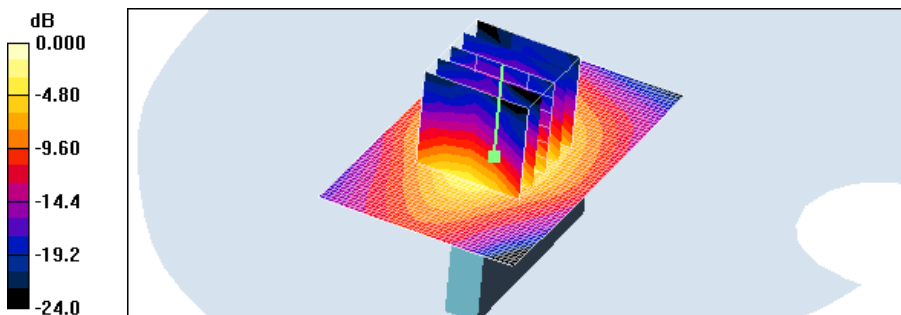

0 dB = 0.156mW/g

Test Laboratory: HCT CO., LTD  
EUT Type: USB Modem  
Liquid Temperature: 21.4 °C  
Ambient Temperature: 21.6 °C  
Test Date: Mar.26, 2010

**DUT: U600; Type: Bar; Serial: #1**

Communication System: WiMAX ; Frequency: 2593 MHz;Duty Cycle: 1:3.24  
Medium parameters used (interpolated):  $f = 2593$  MHz;  $\sigma = 2.17$  mho/m;  $\epsilon_r = 50.7$ ;  $\rho = 1000$  kg/m<sup>3</sup>  
Phantom section: Flat Section ; Measurement SW: DASY4, V4.7 Build 71; Postprocessing SW: SEMCAD, V1.8 Build 176

## DASY4 Configuration:

- Probe: ES3DV2 - SN3017; ConvF(3.78, 3.78, 3.78); Calibrated: 2009-07-22
- Sensor-Surface: 4mm (Mechanical Surface Detection)
- Electronics: DAE4 Sn869; Calibrated: 2009-09-18
- Phantom: SAM 1800/1900 MHz; Type: SAM

**Wimax Body 2593/Area Scan (51x51x1):** Measurement grid: dx=15mm, dy=15mm

[Info: Interpolated medium parameters used for SAR evaluation.](#)

Maximum value of SAR (interpolated) = 0.041 mW/g

**Wimax Body 2593/Zoom Scan (5x5x7)/Cube 0:** Measurement grid: dx=8mm, dy=8mm, dz=5mm

Reference Value = 3.86 V/m; Power Drift = 0.047 dB

Peak SAR (extrapolated) = 0.082 W/kg

**SAR(1 g) = 0.039 mW/g; SAR(10 g) = 0.019 mW/g**

[Info: Interpolated medium parameters used for SAR evaluation.](#)

Maximum value of SAR (measured) = 0.041 mW/g

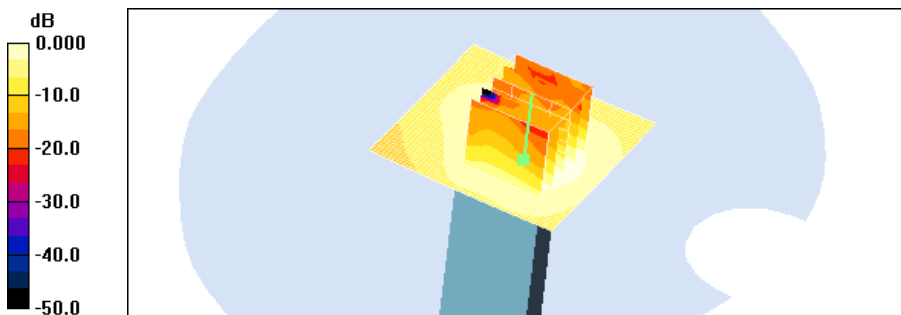

0 dB = 0.041mW/g

Test Laboratory: HCT CO., LTD  
EUT Type: USB Modem  
Liquid Temperature: 21.4 °C  
Ambient Temperature: 21.6 °C  
Test Date: Mar.26, 2010

**DUT: U600; Type: Bar; Serial: #1**

Communication System: WiMAX ; Frequency: 2593 MHz;Duty Cycle: 1:3.24  
Medium parameters used (interpolated):  $f = 2593$  MHz;  $\sigma = 2.17$  mho/m;  $\epsilon_r = 50.7$ ;  $\rho = 1000$  kg/m<sup>3</sup>  
Phantom section: Flat Section ; Measurement SW: DASY4, V4.7 Build 71; Postprocessing SW: SEMCAD, V1.8 Build 176

## DASY4 Configuration:

- Probe: ES3DV2 - SN3017; ConvF(3.78, 3.78, 3.78); Calibrated: 2009-07-22
- Sensor-Surface: 4mm (Mechanical Surface Detection)
- Electronics: DAE4 Sn869; Calibrated: 2009-09-18
- Phantom: SAM 1800/1900 MHz; Type: SAM

**WiMAX Body 2593/Area Scan (41x61x1):** Measurement grid: dx=15mm, dy=15mm

[Info: Interpolated medium parameters used for SAR evaluation.](#)

Maximum value of SAR (interpolated) = 0.284 mW/g

**WiMAX Body 2593/Zoom Scan (5x5x7)/Cube 0:** Measurement grid: dx=8mm, dy=8mm, dz=5mm

Reference Value = 8.09 V/m; Power Drift = -0.171 dB

Peak SAR (extrapolated) = 0.514 W/kg

**SAR(1 g) = 0.243 mW/g; SAR(10 g) = 0.118 mW/g**

[Info: Interpolated medium parameters used for SAR evaluation.](#)

Maximum value of SAR (measured) = 0.264 mW/g

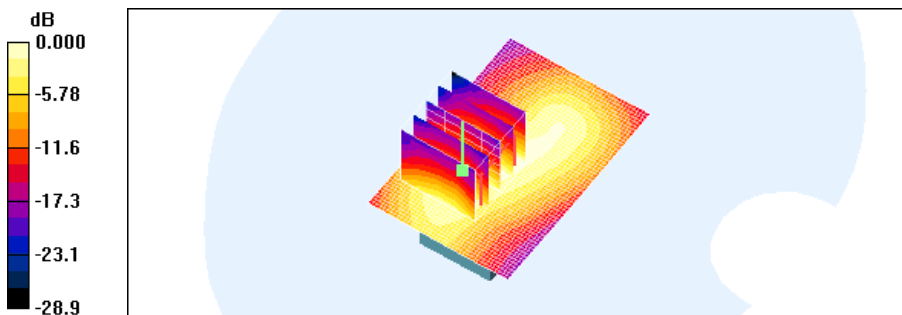

0 dB = 0.264mW/g



Test Laboratory: HCT CO., LTD  
EUT Type: USB Modem  
Liquid Temperature: 21.3 °C  
Ambient Temperature: 21.5 °C  
Test Date: May.05, 2010

**DUT: U600; Type: Bar; Serial: #1**

Communication System: WiMAX 2600MHz FCC; Frequency: 2498.5 MHz; Duty Cycle: 1:3.24  
Medium parameters used (interpolated):  $f = 2498.5$  MHz;  $\sigma = 2.06$  mho/m;  $\epsilon_r = 51.7$ ;  $\rho = 1000$  kg/m<sup>3</sup>  
Phantom section: Flat Section ; Measurement SW: DASY4, V4.7 Build 44; Postprocessing SW: SEMCAD, V1.8 Build 176

## DASY4 Configuration:

- Probe: ES3DV2 - SN3017; ConvF(3.78, 3.78, 3.78); Calibrated: 2009-07-22
- Sensor-Surface: 4mm (Mechanical Surface Detection)
- Electronics: DAE4 Sn869; Calibrated: 2009-09-18
- Phantom: SAM 1800/1900 MHz; Type: SAM

**WiMAX Body/Area Scan (41x61x1):** Measurement grid: dx=15mm, dy=15mm

Maximum value of SAR (interpolated) = 0.328 mW/g

**WiMAX Body/Zoom Scan (5x5x7)/Cube 0:** Measurement grid: dx=8mm, dy=8mm, dz=5mm

Reference Value = 11.7 V/m; Power Drift = -0.001 dB

Peak SAR (extrapolated) = 0.614 W/kg

**SAR(1 g) = 0.299 mW/g; SAR(10 g) = 0.150 mW/g**

Maximum value of SAR (measured) = 0.328 mW/g

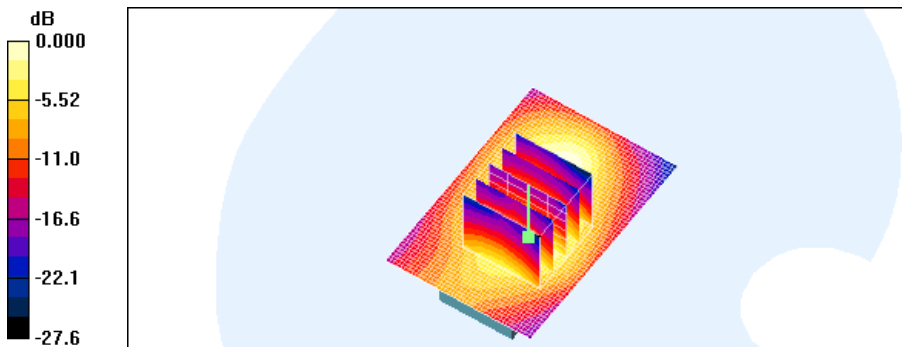

0 dB = 0.328mW/g

Test Laboratory: HCT CO., LTD  
EUT Type: USB Modem  
Liquid Temperature: 21.4 °C  
Ambient Temperature: 21.6 °C  
Test Date: Mar.26, 2010

**DUT: U600; Type: Bar; Serial: #1**

Communication System: WiMAX ; Frequency: 2593 MHz;Duty Cycle: 1:3.24  
Medium parameters used (interpolated):  $f = 2593$  MHz;  $\sigma = 2.17$  mho/m;  $\epsilon_r = 50.7$ ;  $\rho = 1000$  kg/m<sup>3</sup>  
Phantom section: Flat Section ; Measurement SW: DASY4, V4.7 Build 71; Postprocessing SW: SEMCAD, V1.8 Build 176

## DASY4 Configuration:

- Probe: ES3DV2 - SN3017; ConvF(3.78, 3.78, 3.78); Calibrated: 2009-07-22
- Sensor-Surface: 4mm (Mechanical Surface Detection)
- Electronics: DAE4 Sn869; Calibrated: 2009-09-18
- Phantom: SAM 1800/1900 MHz; Type: SAM

**WIMAX Body 2593/Area Scan (41x61x1):** Measurement grid: dx=15mm, dy=15mm

[Info: Interpolated medium parameters used for SAR evaluation.](#)

Maximum value of SAR (interpolated) = 0.733 mW/g

**WIMAX Body 2593/Zoom Scan (5x5x7)/Cube 0:** Measurement grid: dx=8mm, dy=8mm, dz=5mm

Reference Value = 14.3 V/m; Power Drift = -0.114 dB

Peak SAR (extrapolated) = 1.62 W/kg

**SAR(1 g) = 0.675 mW/g; SAR(10 g) = 0.286 mW/g**

[Info: Interpolated medium parameters used for SAR evaluation.](#)

Maximum value of SAR (measured) = 0.742 mW/g

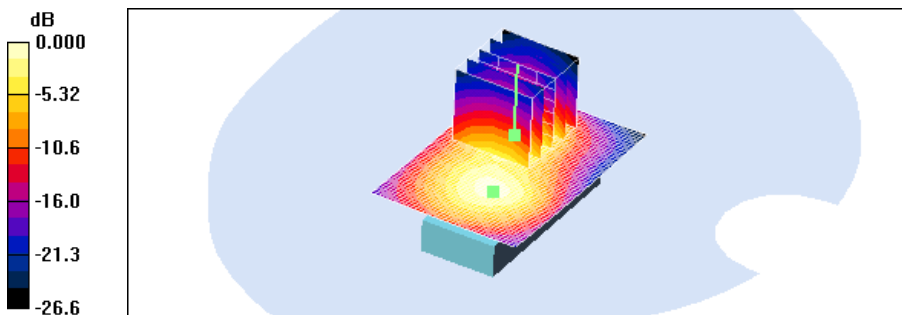

0 dB = 0.742mW/g

Test Laboratory: HCT CO., LTD  
EUT Type: USB Modem  
Liquid Temperature: 21.3 °C  
Ambient Temperature: 21.5 °C  
Test Date: May.05, 2010

**DUT: U600; Type: Bar; Serial: #1**

Communication System: WiMAX 2600MHz FCC; Frequency: 2687.5 MHz; Duty Cycle: 1:3.24  
Medium parameters used (interpolated):  $f = 2687.5$  MHz;  $\sigma = 2.26$  mho/m;  $\epsilon_r = 51.1$ ;  $\rho = 1000$  kg/m<sup>3</sup>  
Phantom section: Flat Section ; Measurement SW: DASY4, V4.7 Build 44; Postprocessing SW: SEMCAD, V1.8 Build 176

## DASY4 Configuration:

- Probe: ES3DV2 - SN3017; ConvF(3.78, 3.78, 3.78); Calibrated: 2009-07-22
- Sensor-Surface: 4mm (Mechanical Surface Detection)
- Electronics: DAE4 Sn869; Calibrated: 2009-09-18
- Phantom: SAM 1800/1900 MHz; Type: SAM

**WiMAX Body/Area Scan (41x61x1):** Measurement grid: dx=15mm, dy=15mm

Maximum value of SAR (interpolated) = 0.364 mW/g

**WiMAX Body/Zoom Scan (5x5x7)/Cube 0:** Measurement grid: dx=8mm, dy=8mm, dz=5mm

Reference Value = 12.5 V/m; Power Drift = 0.187 dB

Peak SAR (extrapolated) = 0.843 W/kg

**SAR(1 g) = 0.338 mW/g; SAR(10 g) = 0.150 mW/g**

Maximum value of SAR (measured) = 0.377 mW/g

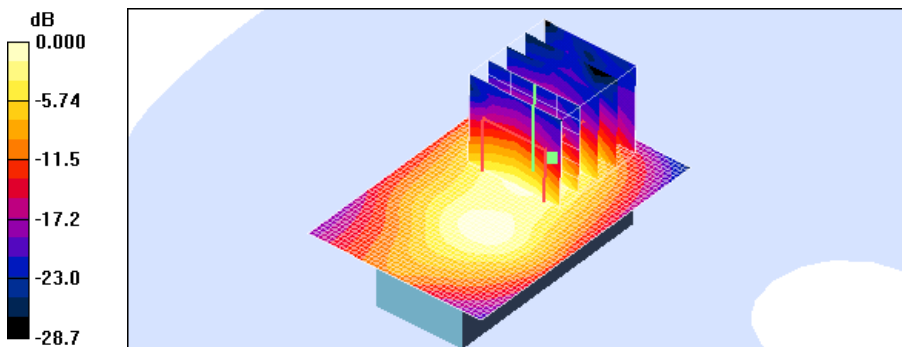

0 dB = 0.377mW/g

Test Laboratory: HCT CO., LTD  
EUT Type: USB Modem  
Liquid Temperature: 21.4 °C  
Ambient Temperature: 21.6 °C  
Test Date: Mar.26, 2010

**DUT: U600; Type: side; Serial: #1**

Communication System: WiMAX ; Frequency: 2593 MHz;Duty Cycle: 1:3.24  
Medium parameters used (interpolated):  $f = 2593$  MHz;  $\sigma = 2.17$  mho/m;  $\epsilon_r = 50.7$ ;  $\rho = 1000$  kg/m<sup>3</sup>  
Phantom section: Flat Section ; Measurement SW: DASY4, V4.7 Build 71; Postprocessing SW: SEMCAD, V1.8 Build 176

DASY4 Configuration:

- Probe: ES3DV2 - SN3017; ConvF(3.78, 3.78, 3.78); Calibrated: 2009-07-22
- Sensor-Surface: 4mm (Mechanical Surface Detection)
- Electronics: DAE4 Sn869; Calibrated: 2009-09-18
- Phantom: SAM 1800/1900 MHz; Type: SAM

**Wimax Body 2593/Area Scan (41x71x1):** Measurement grid: dx=15mm, dy=15mm

[Info: Interpolated medium parameters used for SAR evaluation.](#)

Maximum value of SAR (interpolated) = 0.359 mW/g

**Wimax Body 2593/Zoom Scan (5x5x7)/Cube 0:** Measurement grid: dx=8mm, dy=8mm, dz=5mm

Reference Value = 9.30 V/m; Power Drift = 0.020 dB

Peak SAR (extrapolated) = 0.724 W/kg

**SAR(1 g) = 0.325 mW/g; SAR(10 g) = 0.150 mW/g**

[Info: Interpolated medium parameters used for SAR evaluation.](#)

Maximum value of SAR (measured) = 0.360 mW/g

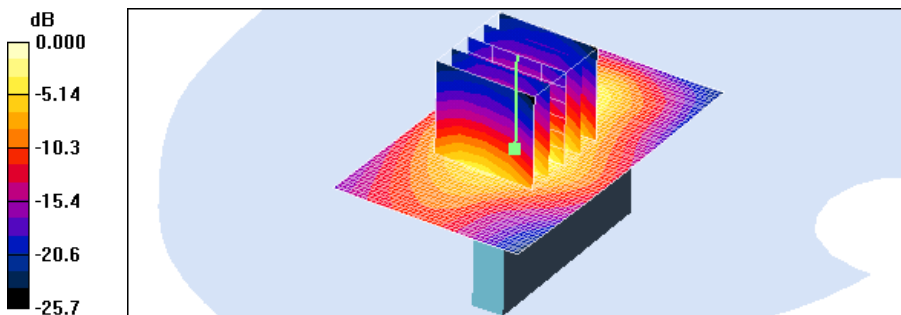

0 dB = 0.360mW/g

Test Laboratory: HCT CO., LTD  
EUT Type: USB Modem  
Liquid Temperature: 21.4 °C  
Ambient Temperature: 21.6 °C  
Test Date: Mar.26, 2010

**DUT: U600; Type: side; Serial: #1**

Communication System: WiMAX ; Frequency: 2593 MHz;Duty Cycle: 1:3.24  
Medium parameters used (interpolated):  $f = 2593$  MHz;  $\sigma = 2.17$  mho/m;  $\epsilon_r = 50.7$ ;  $\rho = 1000$  kg/m<sup>3</sup>  
Phantom section: Flat Section ; Measurement SW: DASY4, V4.7 Build 71; Postprocessing SW: SEMCAD, V1.8 Build 176

DASY4 Configuration:

- Probe: ES3DV2 - SN3017; ConvF(3.78, 3.78, 3.78); Calibrated: 2009-07-22
- Sensor-Surface: 4mm (Mechanical Surface Detection)
- Electronics: DAE4 Sn869; Calibrated: 2009-09-18
- Phantom: SAM 1800/1900 MHz; Type: SAM

**Wimax Body 2593/Area Scan (41x71x1):** Measurement grid: dx=15mm, dy=15mm

[Info: Interpolated medium parameters used for SAR evaluation.](#)

Maximum value of SAR (interpolated) = 0.158 mW/g

**Wimax Body 2593/Zoom Scan (5x5x7)/Cube 0:** Measurement grid: dx=8mm, dy=8mm, dz=5mm

Reference Value = 4.35 V/m; Power Drift = -0.179 dB

Peak SAR (extrapolated) = 0.319 W/kg

**SAR(1 g) = 0.142 mW/g; SAR(10 g) = 0.065 mW/g**

[Info: Interpolated medium parameters used for SAR evaluation.](#)

Maximum value of SAR (measured) = 0.158 mW/g

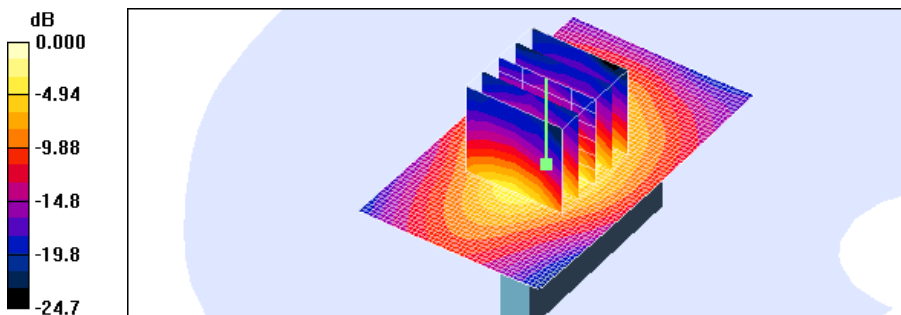

0 dB = 0.158mW/g

Test Laboratory: HCT CO., LTD  
EUT Type: USB Modem  
Liquid Temperature: 21.4 °C  
Ambient Temperature: 21.6 °C  
Test Date: Mar.26, 2010

**DUT: U600; Type: Bar; Serial: #1**

Communication System: WiMAX ; Frequency: 2593 MHz;Duty Cycle: 1:3.24  
Medium parameters used (interpolated):  $f = 2593$  MHz;  $\sigma = 2.17$  mho/m;  $\epsilon_r = 50.7$ ;  $\rho = 1000$  kg/m<sup>3</sup>  
Phantom section: Flat Section ; Measurement SW: DASY4, V4.7 Build 71; Postprocessing SW: SEMCAD, V1.8 Build 176

DASY4 Configuration:

- Probe: ES3DV2 - SN3017; ConvF(3.78, 3.78, 3.78); Calibrated: 2009-07-22
- Sensor-Surface: 4mm (Mechanical Surface Detection)
- Electronics: DAE4 Sn869; Calibrated: 2009-09-18
- Phantom: SAM 1800/1900 MHz; Type: SAM

**Wimax Body 2593/Area Scan (51x51x1):** Measurement grid: dx=15mm, dy=15mm

[Info: Interpolated medium parameters used for SAR evaluation.](#)

Maximum value of SAR (interpolated) = 0.046 mW/g

**Wimax Body 2593/Zoom Scan (5x5x7)/Cube 0:** Measurement grid: dx=8mm, dy=8mm, dz=5mm

Reference Value = 3.94 V/m; Power Drift = -0.058 dB

Peak SAR (extrapolated) = 0.082 W/kg

**SAR(1 g) = 0.041 mW/g; SAR(10 g) = 0.019 mW/g**

[Info: Interpolated medium parameters used for SAR evaluation.](#)

Maximum value of SAR (measured) = 0.044 mW/g

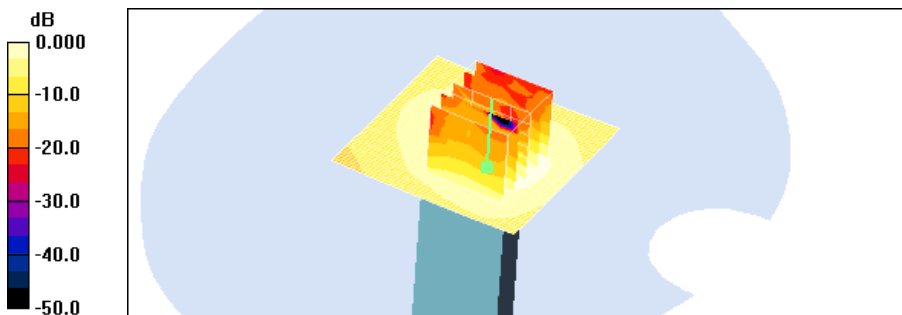

0 dB = 0.044mW/g

Test Laboratory: HCT CO., LTD  
EUT Type: USB Modem  
Liquid Temperature: 21.4 °C  
Ambient Temperature: 21.6 °C  
Test Date: Mar.26, 2010

**DUT: U600; Type: Bar; Serial: #1**

Communication System: WiMAX ; Frequency: 2593 MHz;Duty Cycle: 1:3.24  
Medium parameters used (interpolated):  $f = 2593$  MHz;  $\sigma = 2.17$  mho/m;  $\epsilon_r = 50.7$ ;  $\rho = 1000$  kg/m<sup>3</sup>  
Phantom section: Flat Section ; Measurement SW: DASY4, V4.7 Build 71; Postprocessing SW: SEMCAD, V1.8 Build 176

## DASY4 Configuration:

- Probe: ES3DV2 - SN3017; ConvF(3.78, 3.78, 3.78); Calibrated: 2009-07-22
- Sensor-Surface: 4mm (Mechanical Surface Detection)
- Electronics: DAE4 Sn869; Calibrated: 2009-09-18
- Phantom: SAM 1800/1900 MHz; Type: SAM

**WiMAX Body 2593/Area Scan (41x61x1):** Measurement grid: dx=15mm, dy=15mm

[Info: Interpolated medium parameters used for SAR evaluation.](#)

Maximum value of SAR (interpolated) = 0.283 mW/g

**WiMAX Body 2593/Zoom Scan (5x5x7)/Cube 0:** Measurement grid: dx=8mm, dy=8mm, dz=5mm

Reference Value = 8.01 V/m; Power Drift = -0.107 dB

Peak SAR (extrapolated) = 0.507 W/kg

**SAR(1 g) = 0.241 mW/g; SAR(10 g) = 0.117 mW/g**

[Info: Interpolated medium parameters used for SAR evaluation.](#)

Maximum value of SAR (measured) = 0.263 mW/g

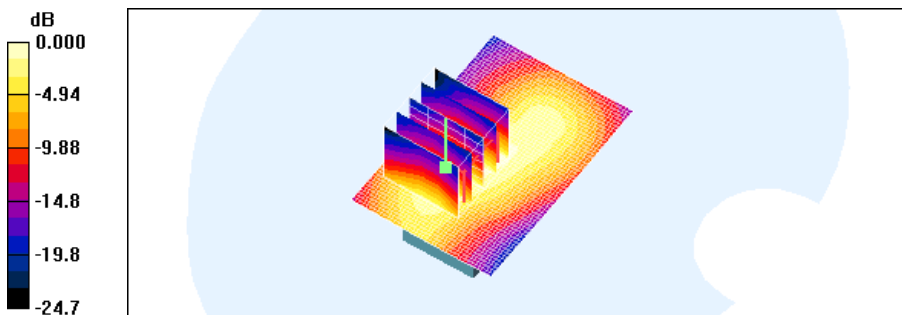

0 dB = 0.263mW/g

Test Laboratory: HCT CO., LTD  
EUT Type: USB Modem  
Liquid Temperature: 21.3 °C  
Ambient Temperature: 21.5 °C  
Test Date: May.05, 2010

**DUT: U600; Type: Bar; Serial: #1**

Communication System: WiMAX 2600MHz FCC; Frequency: 2498.5 MHz; Duty Cycle: 1:3.24  
Medium parameters used (interpolated):  $f = 2498.5$  MHz;  $\sigma = 2.06$  mho/m;  $\epsilon_r = 51.7$ ;  $\rho = 1000$  kg/m<sup>3</sup>  
Phantom section: Flat Section ; Measurement SW: DASY4, V4.7 Build 44; Postprocessing SW: SEMCAD, V1.8 Build 176

## DASY4 Configuration:

- Probe: ES3DV2 - SN3017; ConvF(3.78, 3.78, 3.78); Calibrated: 2009-07-22
- Sensor-Surface: 4mm (Mechanical Surface Detection)
- Electronics: DAE4 Sn869; Calibrated: 2009-09-18
- Phantom: SAM 1800/1900 MHz; Type: SAM

**WiMAX Body/Area Scan (41x61x1):** Measurement grid: dx=15mm, dy=15mm

Maximum value of SAR (interpolated) = 0.339 mW/g

**WiMAX Body/Zoom Scan (5x5x7)/Cube 0:** Measurement grid: dx=8mm, dy=8mm, dz=5mm

Reference Value = 11.8 V/m; Power Drift = -0.008 dB

Peak SAR (extrapolated) = 0.621 W/kg

**SAR(1 g) = 0.302 mW/g; SAR(10 g) = 0.153 mW/g**

Maximum value of SAR (measured) = 0.327 mW/g

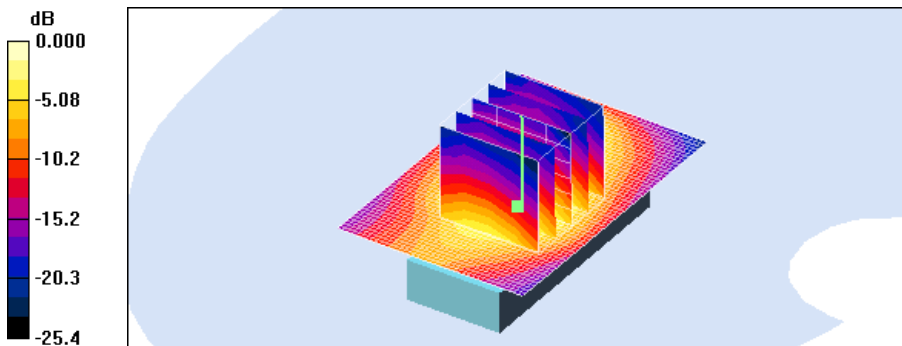

0 dB = 0.327mW/g



Test Laboratory: HCT CO., LTD  
EUT Type: USB Modem  
Liquid Temperature: 21.4 °C  
Ambient Temperature: 21.6 °C  
Test Date: Mar.26, 2010

**DUT: U600; Type: Bar; Serial: #1**

Communication System: WiMAX ; Frequency: 2593 MHz;Duty Cycle: 1:3.24  
Medium parameters used (interpolated):  $f = 2593$  MHz;  $\sigma = 2.17$  mho/m;  $\epsilon_r = 50.7$ ;  $\rho = 1000$  kg/m<sup>3</sup>  
Phantom section: Flat Section ; Measurement SW: DASY4, V4.7 Build 71; Postprocessing SW: SEMCAD, V1.8 Build 176

## DASY4 Configuration:

- Probe: ES3DV2 - SN3017; ConvF(3.78, 3.78, 3.78); Calibrated: 2009-07-22
- Sensor-Surface: 4mm (Mechanical Surface Detection)
- Electronics: DAE4 Sn869; Calibrated: 2009-09-18
- Phantom: SAM 1800/1900 MHz; Type: SAM

**WiMAX Body 2593/Area Scan (41x61x1):** Measurement grid: dx=15mm, dy=15mm

[Info: Interpolated medium parameters used for SAR evaluation.](#)

Maximum value of SAR (interpolated) = 0.703 mW/g

**WiMAX Body 2593/Zoom Scan (5x5x7)/Cube 0:** Measurement grid: dx=8mm, dy=8mm, dz=5mm

Reference Value = 14.2 V/m; Power Drift = -0.027 dB

Peak SAR (extrapolated) = 1.58 W/kg

**SAR(1 g) = 0.672 mW/g; SAR(10 g) = 0.285 mW/g**

Maximum value of SAR (measured) = 0.743 mW/g

**WiMAX Body 2593/Zoom Scan (5x5x7)/Cube 1:** Measurement grid: dx=8mm, dy=8mm, dz=5mm

Reference Value = 14.2 V/m; Power Drift = -0.027 dB

Peak SAR (extrapolated) = 1.12 W/kg

SAR(1 g) = 0.536 mW/g; SAR(10 g) = 0.262 mW/g

[Info: Interpolated medium parameters used for SAR evaluation.](#)

Maximum value of SAR (measured) = 0.592 mW/g

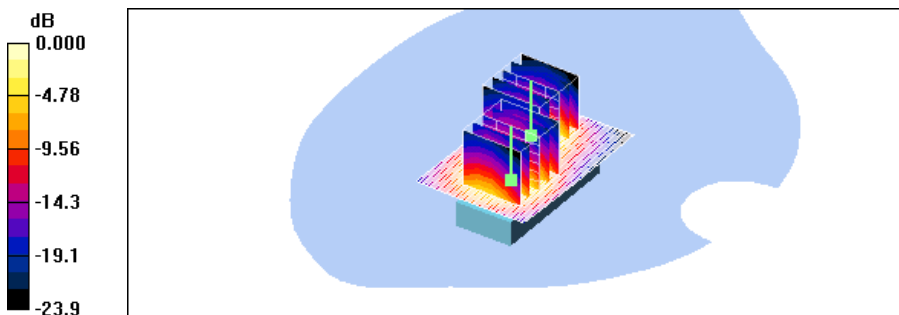

0 dB = 0.592mW/g

Test Laboratory: HCT CO., LTD  
EUT Type: USB Modem  
Liquid Temperature: 21.3 °C  
Ambient Temperature: 21.5 °C  
Test Date: May.05, 2010

**DUT: U600; Type: Bar; Serial: #1**

Communication System: WiMAX 2600MHz FCC; Frequency: 2687.5 MHz; Duty Cycle: 1:3.24  
Medium parameters used (interpolated):  $f = 2687.5$  MHz;  $\sigma = 2.26$  mho/m;  $\epsilon_r = 51.1$ ;  $\rho = 1000$  kg/m<sup>3</sup>  
Phantom section: Flat Section ; Measurement SW: DASY4, V4.7 Build 44; Postprocessing SW: SEMCAD, V1.8 Build 176

## DASY4 Configuration:

- Probe: ES3DV2 - SN3017; ConvF(3.78, 3.78, 3.78); Calibrated: 2009-07-22
- Sensor-Surface: 4mm (Mechanical Surface Detection)
- Electronics: DAE4 Sn869; Calibrated: 2009-09-18
- Phantom: SAM 1800/1900 MHz; Type: SAM

**WiMAX Body/Area Scan (41x61x1):** Measurement grid: dx=15mm, dy=15mm

[Info: Interpolated medium parameters used for SAR evaluation.](#)

Maximum value of SAR (interpolated) = 0.345 mW/g

**WiMAX Body/Zoom Scan (5x5x7)/Cube 0:** Measurement grid: dx=8mm, dy=8mm, dz=5mm

Reference Value = 12.3 V/m; Power Drift = -0.083 dB

Peak SAR (extrapolated) = 0.956 W/kg

**SAR(1 g) = 0.355 mW/g; SAR(10 g) = 0.153 mW/g**

Maximum value of SAR (measured) = 0.359 mW/g

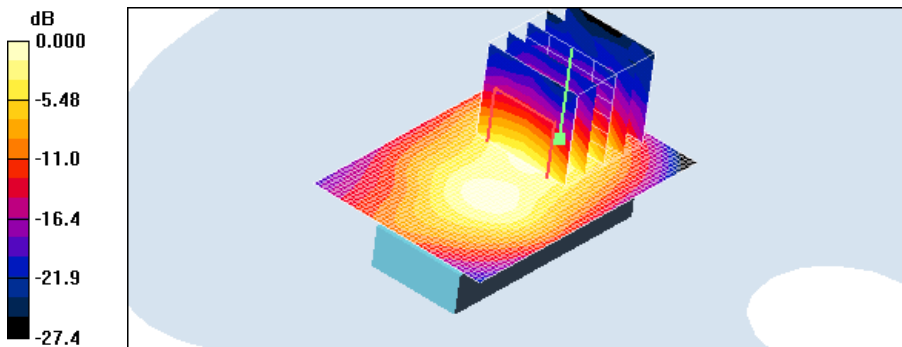

0 dB = 0.359mW/g

Test Laboratory: HCT CO., LTD  
EUT Type: USB Modem  
Liquid Temperature: 21.4 °C  
Ambient Temperature: 21.6 °C  
Test Date: Mar.26, 2010

**DUT: U600; Type: side; Serial: #1**

Communication System: WiMAX ; Frequency: 2593 MHz;Duty Cycle: 1:3.24  
Medium parameters used (interpolated):  $f = 2593$  MHz;  $\sigma = 2.17$  mho/m;  $\epsilon_r = 50.7$ ;  $\rho = 1000$  kg/m<sup>3</sup>  
Phantom section: Flat Section ; Measurement SW: DASY4, V4.7 Build 71; Postprocessing SW: SEMCAD, V1.8 Build 176

DASY4 Configuration:

- Probe: ES3DV2 - SN3017; ConvF(3.78, 3.78, 3.78); Calibrated: 2009-07-22
- Sensor-Surface: 4mm (Mechanical Surface Detection)
- Electronics: DAE4 Sn869; Calibrated: 2009-09-18
- Phantom: SAM 1800/1900 MHz; Type: SAM

**Wimax Body 2593/Area Scan (41x71x1):** Measurement grid: dx=15mm, dy=15mm

[Info: Interpolated medium parameters used for SAR evaluation.](#)

Maximum value of SAR (interpolated) = 0.325 mW/g

**Wimax Body 2593/Zoom Scan (5x5x7)/Cube 0:** Measurement grid: dx=8mm, dy=8mm, dz=5mm

Reference Value = 8.29 V/m; Power Drift = 0.031 dB

Peak SAR (extrapolated) = 0.656 W/kg

**SAR(1 g) = 0.299 mW/g; SAR(10 g) = 0.138 mW/g**

[Info: Interpolated medium parameters used for SAR evaluation.](#)

Maximum value of SAR (measured) = 0.329 mW/g

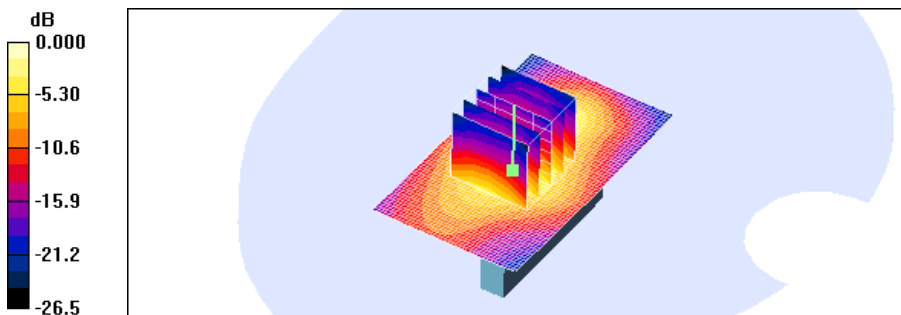

0 dB = 0.329mW/g

Test Laboratory: HCT CO., LTD  
EUT Type: USB Modem  
Liquid Temperature: 21.4 °C  
Ambient Temperature: 21.6 °C  
Test Date: Mar.26, 2010

**DUT: U600; Type: side; Serial: #1**

Communication System: WiMAX ; Frequency: 2593 MHz;Duty Cycle: 1:3.24  
Medium parameters used (interpolated):  $f = 2593$  MHz;  $\sigma = 2.17$  mho/m;  $\epsilon_r = 50.7$ ;  $\rho = 1000$  kg/m<sup>3</sup>  
Phantom section: Flat Section ; Measurement SW: DASY4, V4.7 Build 71; Postprocessing SW: SEMCAD, V1.8 Build 176

DASY4 Configuration:

- Probe: ES3DV2 - SN3017; ConvF(3.78, 3.78, 3.78); Calibrated: 2009-07-22
- Sensor-Surface: 4mm (Mechanical Surface Detection)
- Electronics: DAE4 Sn869; Calibrated: 2009-09-18
- Phantom: SAM 1800/1900 MHz; Type: SAM

**Wimax Body 2593/Area Scan (41x71x1):** Measurement grid: dx=15mm, dy=15mm

[Info: Interpolated medium parameters used for SAR evaluation.](#)

Maximum value of SAR (interpolated) = 0.159 mW/g

**Wimax Body 2593/Zoom Scan (5x5x7)/Cube 0:** Measurement grid: dx=8mm, dy=8mm, dz=5mm

Reference Value = 4.30 V/m; Power Drift = 0.014 dB

Peak SAR (extrapolated) = 0.304 W/kg

**SAR(1 g) = 0.137 mW/g; SAR(10 g) = 0.063 mW/g**

[Info: Interpolated medium parameters used for SAR evaluation.](#)

Maximum value of SAR (measured) = 0.151 mW/g

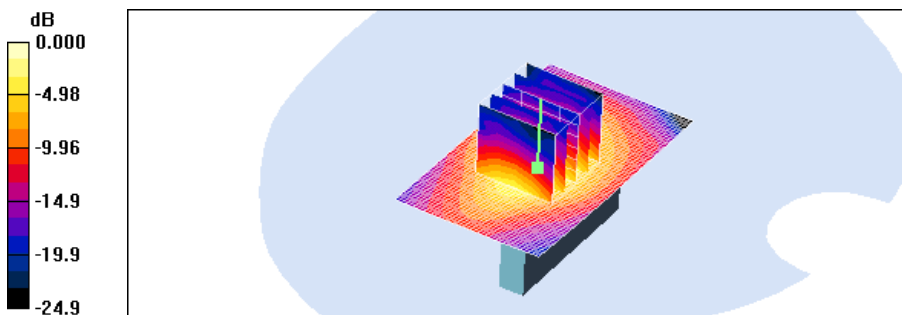

Test Laboratory: HCT CO., LTD  
EUT Type: USB Modem  
Liquid Temperature: 21.4 °C  
Ambient Temperature: 21.6 °C  
Test Date: Mar.26, 2010

**DUT: U600; Type: Bar; Serial: #1**

Communication System: WiMAX ; Frequency: 2593 MHz;Duty Cycle: 1:3.24  
Medium parameters used (interpolated):  $f = 2593$  MHz;  $\sigma = 2.17$  mho/m;  $\epsilon_r = 50.7$ ;  $\rho = 1000$  kg/m<sup>3</sup>  
Phantom section: Flat Section ; Measurement SW: DASY4, V4.7 Build 71; Postprocessing SW: SEMCAD, V1.8 Build 176

## DASY4 Configuration:

- Probe: ES3DV2 - SN3017; ConvF(3.78, 3.78, 3.78); Calibrated: 2009-07-22
- Sensor-Surface: 4mm (Mechanical Surface Detection)
- Electronics: DAE4 Sn869; Calibrated: 2009-09-18
- Phantom: SAM 1800/1900 MHz; Type: SAM

**Wimax Body 2593/Area Scan (51x51x1):** Measurement grid: dx=15mm, dy=15mm

[Info: Interpolated medium parameters used for SAR evaluation.](#)

Maximum value of SAR (interpolated) = 0.044 mW/g

**Wimax Body 2593/Zoom Scan (5x5x7)/Cube 0:** Measurement grid: dx=8mm, dy=8mm, dz=5mm

Reference Value = 3.90 V/m; Power Drift = 0.053 dB

Peak SAR (extrapolated) = 0.075 W/kg

**SAR(1 g) = 0.038 mW/g; SAR(10 g) = 0.018 mW/g**

[Info: Interpolated medium parameters used for SAR evaluation.](#)

Maximum value of SAR (measured) = 0.041 mW/g

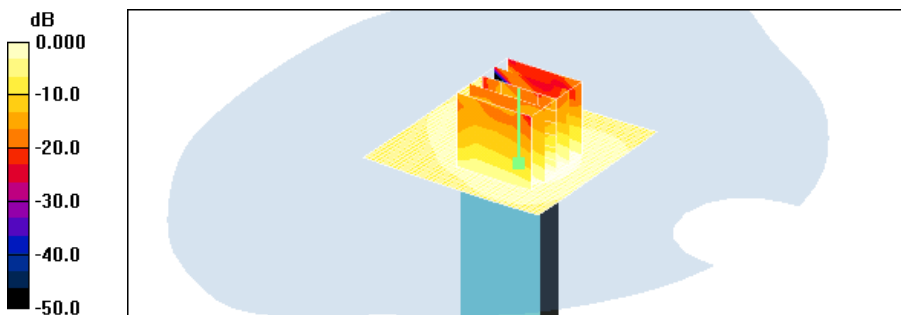

0 dB = 0.041mW/g

Test Laboratory: HCT CO., LTD  
EUT Type: USB Modem  
Liquid Temperature: 21.4 °C  
Ambient Temperature: 21.6 °C  
Test Date: Mar.26, 2010

**DUT: U600; Type: Bar; Serial: #1**

Communication System: WiMAX 10MHz; Frequency: 2593 MHz; Duty Cycle: 1:3.24  
Medium parameters used (interpolated):  $f = 2593$  MHz;  $\sigma = 2.17$  mho/m;  $\epsilon_r = 50.7$ ;  $\rho = 1000$  kg/m<sup>3</sup>  
Phantom section: Flat Section ; Measurement SW: DASY4, V4.7 Build 71; Postprocessing SW: SEMCAD, V1.8 Build 176

## DASY4 Configuration:

- Probe: ES3DV2 - SN3017; ConvF(3.78, 3.78, 3.78); Calibrated: 2009-07-22
- Sensor-Surface: 4mm (Mechanical Surface Detection)
- Electronics: DAE4 Sn869; Calibrated: 2009-09-18
- Phantom: SAM 1800/1900 MHz; Type: SAM

**WiMAX Body 2593/Area Scan (41x61x1):** Measurement grid: dx=15mm, dy=15mm

[Info: Interpolated medium parameters used for SAR evaluation.](#)

Maximum value of SAR (interpolated) = 0.358 mW/g

**WiMAX Body 2593/Zoom Scan (5x5x7)/Cube 0:** Measurement grid: dx=8mm, dy=8mm, dz=5mm

Reference Value = 11.5 V/m; Power Drift = -0.186 dB

Peak SAR (extrapolated) = 0.549 W/kg

**SAR(1 g) = 0.267 mW/g; SAR(10 g) = 0.132 mW/g**

[Info: Interpolated medium parameters used for SAR evaluation.](#)

Maximum value of SAR (measured) = 0.286 mW/g

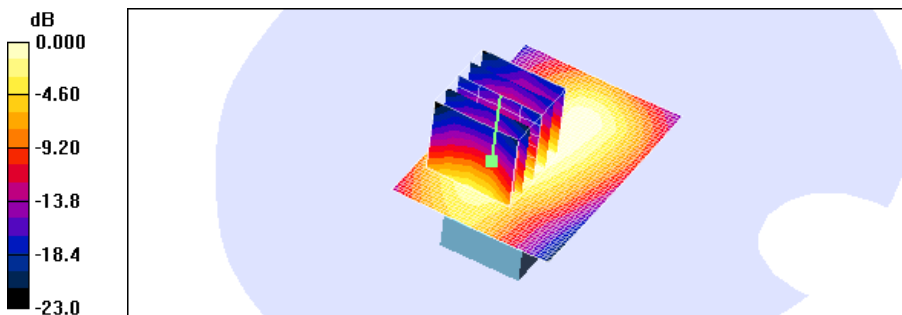

0 dB = 0.286mW/g

Test Laboratory: HCT CO., LTD  
EUT Type: USB Modem  
Liquid Temperature: 21.3 °C  
Ambient Temperature: 21.5 °C  
Test Date: May.05, 2010

**DUT: U600; Type: Bar; Serial: #1**

Communication System: WiMAX 2600MHz FCC; Frequency: 2501 MHz; Duty Cycle: 1: 3.24  
Medium parameters used (interpolated):  $f = 2501$  MHz;  $\sigma = 2.06$  mho/m;  $\epsilon_r = 51.7$ ;  $\rho = 1000$  kg/m<sup>3</sup>  
Phantom section: Flat Section ; Measurement SW: DASY4, V4.7 Build 44; Postprocessing SW: SEMCAD, V1.8 Build 176

## DASY4 Configuration:

- Probe: ES3DV2 - SN3017; ConvF(3.78, 3.78, 3.78); Calibrated: 2009-07-22
- Sensor-Surface: 4mm (Mechanical Surface Detection)
- Electronics: DAE4 Sn869; Calibrated: 2009-09-18
- Phantom: SAM 1800/1900 MHz; Type: SAM

**WiMAX Body/Area Scan (41x61x1):** Measurement grid: dx=15mm, dy=15mm  
Maximum value of SAR (interpolated) = 0.297 mW/g

**WiMAX Body/Zoom Scan (5x5x7)/Cube 0:** Measurement grid: dx=8mm, dy=8mm, dz=5mm  
Reference Value = 11.1 V/m; Power Drift = 0.152 dB  
Peak SAR (extrapolated) = 0.553 W/kg  
**SAR(1 g) = 0.269 mW/g; SAR(10 g) = 0.135 mW/g**

Maximum value of SAR (measured) = 0.294 mW/g

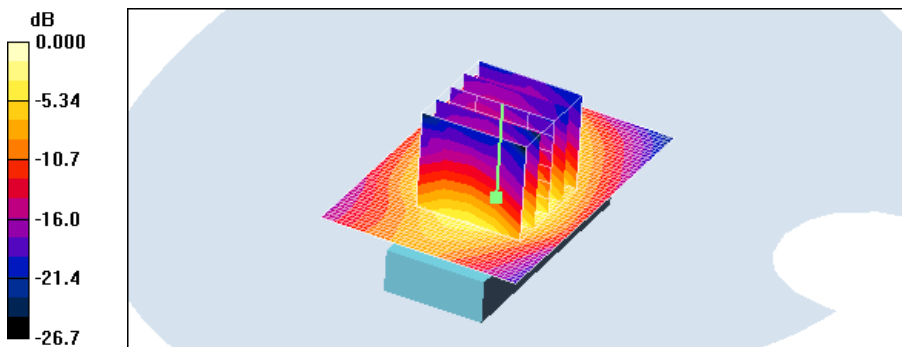

0 dB = 0.294mW/g

Test Laboratory: HCT CO., LTD  
EUT Type: USB Modem  
Liquid Temperature: 21.4 °C  
Ambient Temperature: 21.6 °C  
Test Date: Mar.26, 2010

**DUT: U600; Type: Bar; Serial: #1**

Communication System: WiMAX 10MHz; Frequency: 2593 MHz; Duty Cycle: 1:3.24  
Medium parameters used (interpolated):  $f = 2593$  MHz;  $\sigma = 2.17$  mho/m;  $\epsilon_r = 50.7$ ;  $\rho = 1000$  kg/m<sup>3</sup>  
Phantom section: Flat Section ; Measurement SW: DASY4, V4.7 Build 71; Postprocessing SW: SEMCAD, V1.8 Build 176

## DASY4 Configuration:

- Probe: ES3DV2 - SN3017; ConvF(3.78, 3.78, 3.78); Calibrated: 2009-07-22
- Sensor-Surface: 4mm (Mechanical Surface Detection)
- Electronics: DAE4 Sn869; Calibrated: 2009-09-18
- Phantom: SAM 1800/1900 MHz; Type: SAM

**WIMAX Body 2593/Area Scan (41x61x1):** Measurement grid: dx=15mm, dy=15mm

[Info: Interpolated medium parameters used for SAR evaluation.](#)

Maximum value of SAR (interpolated) = 0.718 mW/g

**WIMAX Body 2593/Zoom Scan (5x5x7)/Cube 0:** Measurement grid: dx=8mm, dy=8mm, dz=5mm

Reference Value = 16.5 V/m; Power Drift = -0.079 dB

Peak SAR (extrapolated) = 1.63 W/kg

**SAR(1 g) = 0.672 mW/g; SAR(10 g) = 0.280 mW/g**

[Info: Interpolated medium parameters used for SAR evaluation.](#)

Maximum value of SAR (measured) = 0.761 mW/g

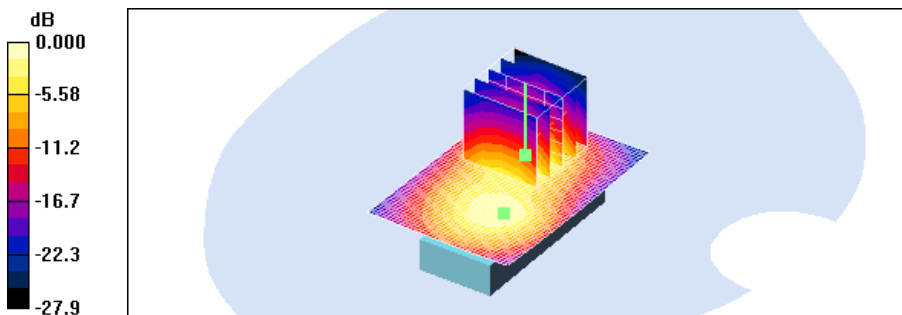

0 dB = 0.761mW/g



Test Laboratory: HCT CO., LTD  
EUT Type: USB Modem  
Liquid Temperature: 21.3 °C  
Ambient Temperature: 21.5 °C  
Test Date: May.05, 2010

**DUT: U600; Type: Bar; Serial: #1**

Communication System: WiMAX 2600MHz FCC; Frequency: 2685 MHz; Duty Cycle: 1: 3.24  
Medium parameters used (interpolated):  $f = 2685$  MHz;  $\sigma = 2.26$  mho/m;  $\epsilon_r = 51.1$ ;  $\rho = 1000$  kg/m<sup>3</sup>  
Phantom section: Flat Section ; Measurement SW: DASY4, V4.7 Build 44; Postprocessing SW: SEMCAD, V1.8 Build 176

## DASY4 Configuration:

- Probe: ES3DV2 - SN3017; ConvF(3.78, 3.78, 3.78); Calibrated: 2009-07-22
- Sensor-Surface: 4mm (Mechanical Surface Detection)
- Electronics: DAE4 Sn869; Calibrated: 2009-09-18
- Phantom: SAM 1800/1900 MHz; Type: SAM

**WiMAX Body/Area Scan (41x61x1):** Measurement grid: dx=15mm, dy=15mm

[Info: Interpolated medium parameters used for SAR evaluation.](#)

Maximum value of SAR (interpolated) = 0.332 mW/g

**WiMAX Body/Zoom Scan (5x5x7)/Cube 0:** Measurement grid: dx=8mm, dy=8mm, dz=5mm

Reference Value = 11.9 V/m; Power Drift = -0.022 dB

Peak SAR (extrapolated) = 0.876 W/kg

**SAR(1 g) = 0.327 mW/g; SAR(10 g) = 0.139 mW/g**

Maximum value of SAR (measured) = 0.348 mW/g

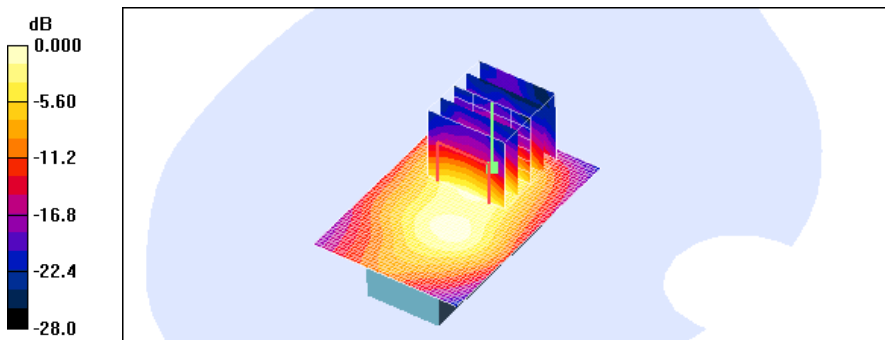

0 dB = 0.348mW/g

Test Laboratory: HCT CO., LTD  
EUT Type: USB Modem  
Liquid Temperature: 21.4 °C  
Ambient Temperature: 21.6 °C  
Test Date: Mar.26, 2010

**DUT: U600; Type: side; Serial: #1**

Communication System: WiMAX 10MHz; Frequency: 2593 MHz; Duty Cycle: 1:3.24  
Medium parameters used (interpolated):  $f = 2593$  MHz;  $\sigma = 2.17$  mho/m;  $\epsilon_r = 50.7$ ;  $\rho = 1000$  kg/m<sup>3</sup>  
Phantom section: Flat Section ; Measurement SW: DASY4, V4.7 Build 71; Postprocessing SW: SEMCAD, V1.8 Build 176

DASY4 Configuration:

- Probe: ES3DV2 - SN3017; ConvF(3.78, 3.78, 3.78); Calibrated: 2009-07-22
- Sensor-Surface: 4mm (Mechanical Surface Detection)
- Electronics: DAE4 Sn869; Calibrated: 2009-09-18
- Phantom: SAM 1800/1900 MHz; Type: SAM

**WiMAX Body 2593/Area Scan (41x61x1):** Measurement grid: dx=15mm, dy=15mm

[Info: Interpolated medium parameters used for SAR evaluation.](#)

Maximum value of SAR (interpolated) = 0.330 mW/g

**WiMAX Body 2593/Zoom Scan (5x5x7)/Cube 0:** Measurement grid: dx=8mm, dy=8mm, dz=5mm

Reference Value = 9.94 V/m; Power Drift = -0.073 dB

Peak SAR (extrapolated) = 0.514 W/kg

**SAR(1 g) = 0.252 mW/g; SAR(10 g) = 0.121 mW/g**

[Info: Interpolated medium parameters used for SAR evaluation.](#)

Maximum value of SAR (measured) = 0.284 mW/g

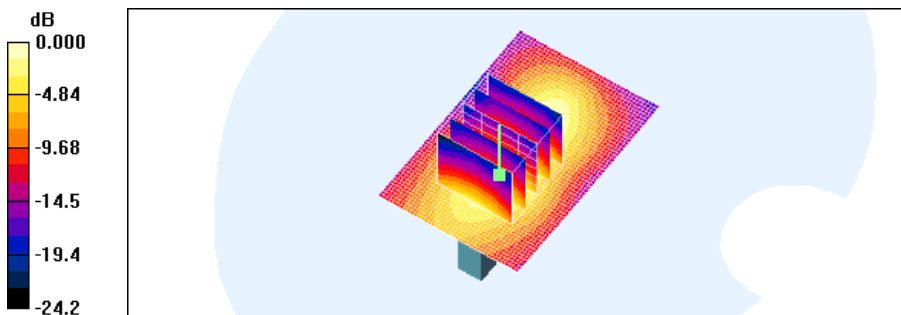

0 dB = 0.284mW/g

Test Laboratory: HCT CO., LTD  
EUT Type: USB Modem  
Liquid Temperature: 21.4 °C  
Ambient Temperature: 21.6 °C  
Test Date: Mar.26, 2010

**DUT: U600; Type: side; Serial: #1**

Communication System: WiMAX 10MHz; Frequency: 2593 MHz; Duty Cycle: 1:3.24  
Medium parameters used (interpolated):  $f = 2593$  MHz;  $\sigma = 2.17$  mho/m;  $\epsilon_r = 50.7$ ;  $\rho = 1000$  kg/m<sup>3</sup>  
Phantom section: Flat Section ; Measurement SW: DASY4, V4.7 Build 71; Postprocessing SW: SEMCAD, V1.8 Build 176

DASY4 Configuration:

- Probe: ES3DV2 - SN3017; ConvF(3.78, 3.78, 3.78); Calibrated: 2009-07-22
- Sensor-Surface: 4mm (Mechanical Surface Detection)
- Electronics: DAE4 Sn869; Calibrated: 2009-09-18
- Phantom: SAM 1800/1900 MHz; Type: SAM

**Wimax Body 2593/Area Scan (41x71x1):** Measurement grid: dx=15mm, dy=15mm

[Info: Interpolated medium parameters used for SAR evaluation.](#)

Maximum value of SAR (interpolated) = 0.173 mW/g

**Wimax Body 2593/Zoom Scan (5x5x7)/Cube 0:** Measurement grid: dx=8mm, dy=8mm, dz=5mm

Reference Value = 4.63 V/m; Power Drift = -0.060 dB

Peak SAR (extrapolated) = 0.317 W/kg

**SAR(1 g) = 0.140 mW/g; SAR(10 g) = 0.065 mW/g**

[Info: Interpolated medium parameters used for SAR evaluation.](#)

Maximum value of SAR (measured) = 0.153 mW/g

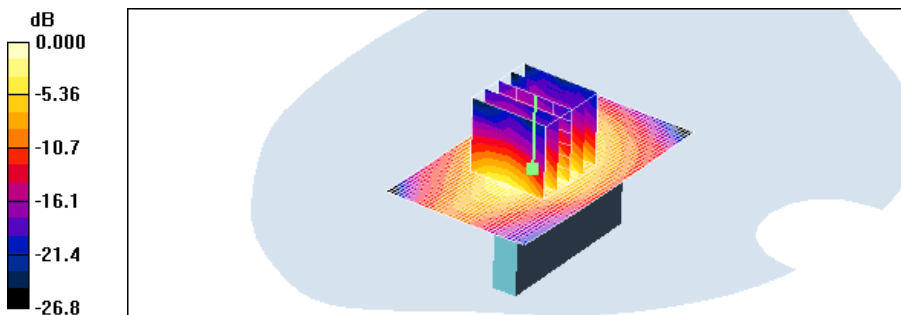

Test Laboratory: HCT CO., LTD  
EUT Type: USB Modem  
Liquid Temperature: 21.4 °C  
Ambient Temperature: 21.6 °C  
Test Date: Mar.26, 2010

**DUT: U600; Type: Bar; Serial: #1**

Communication System: WiMAX 10MHz; Frequency: 2593 MHz; Duty Cycle: 1:3.24  
Medium parameters used (interpolated):  $f = 2593$  MHz;  $\sigma = 2.17$  mho/m;  $\epsilon_r = 50.7$ ;  $\rho = 1000$  kg/m<sup>3</sup>  
Phantom section: Flat Section ; Measurement SW: DASY4, V4.7 Build 71; Postprocessing SW: SEMCAD, V1.8 Build 176

## DASY4 Configuration:

- Probe: ES3DV2 - SN3017; ConvF(3.78, 3.78, 3.78); Calibrated: 2009-07-22
- Sensor-Surface: 4mm (Mechanical Surface Detection)
- Electronics: DAE4 Sn869; Calibrated: 2009-09-18
- Phantom: SAM 1800/1900 MHz; Type: SAM

**Wimax Body 2593/Area Scan (51x51x1):** Measurement grid: dx=15mm, dy=15mm

[Info: Interpolated medium parameters used for SAR evaluation.](#)

Maximum value of SAR (interpolated) = 0.042 mW/g

**Wimax Body 2593/Zoom Scan (5x5x7)/Cube 0:** Measurement grid: dx=8mm, dy=8mm, dz=5mm

Reference Value = 3.77 V/m; Power Drift = 0.011 dB

Peak SAR (extrapolated) = 0.083 W/kg

**SAR(1 g) = 0.038 mW/g; SAR(10 g) = 0.018 mW/g**

[Info: Interpolated medium parameters used for SAR evaluation.](#)

Maximum value of SAR (measured) = 0.040 mW/g

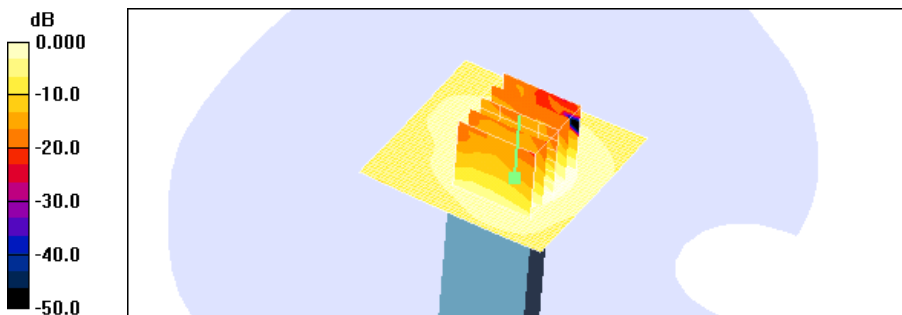

0 dB = 0.040mW/g

Test Laboratory: HCT CO., LTD  
EUT Type: USB Modem  
Liquid Temperature: 21.4 °C  
Ambient Temperature: 21.6 °C  
Test Date: Mar.26, 2010

**DUT: U600; Type: Bar; Serial: #1**

Communication System: WiMAX 10MHz; Frequency: 2593 MHz; Duty Cycle: 1:3.24  
Medium parameters used (interpolated):  $f = 2593$  MHz;  $\sigma = 2.17$  mho/m;  $\epsilon_r = 50.7$ ;  $\rho = 1000$  kg/m<sup>3</sup>  
Phantom section: Flat Section ; Measurement SW: DASY4, V4.7 Build 71; Postprocessing SW: SEMCAD, V1.8 Build 176

## DASY4 Configuration:

- Probe: ES3DV2 - SN3017; ConvF(3.78, 3.78, 3.78); Calibrated: 2009-07-22
- Sensor-Surface: 4mm (Mechanical Surface Detection)
- Electronics: DAE4 Sn869; Calibrated: 2009-09-18
- Phantom: SAM 1800/1900 MHz; Type: SAM

**WiMAX Body 2593/Area Scan (41x61x1):** Measurement grid: dx=15mm, dy=15mm

[Info: Interpolated medium parameters used for SAR evaluation.](#)

Maximum value of SAR (interpolated) = 0.469 mW/g

**WiMAX Body 2593/Zoom Scan (5x5x7)/Cube 0:** Measurement grid: dx=8mm, dy=8mm, dz=5mm

Reference Value = 11.1 V/m; Power Drift = -0.029 dB

Peak SAR (extrapolated) = 0.701 W/kg

**SAR(1 g) = 0.321 mW/g; SAR(10 g) = 0.153 mW/g**

[Info: Interpolated medium parameters used for SAR evaluation.](#)

Maximum value of SAR (measured) = 0.350 mW/g

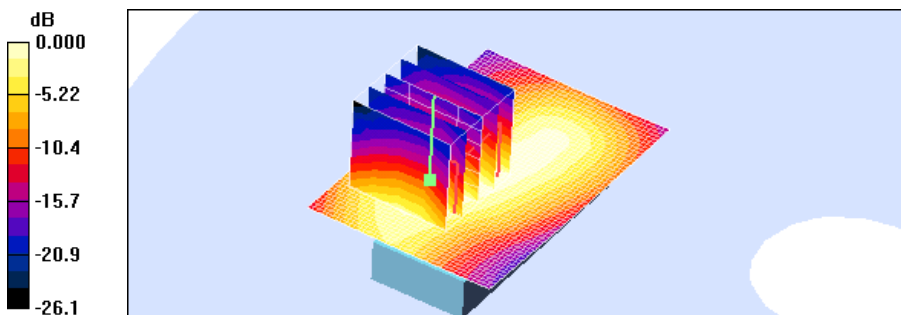

0 dB = 0.350mW/g

Test Laboratory: HCT CO., LTD  
EUT Type: USB Modem  
Liquid Temperature: 21.3 °C  
Ambient Temperature: 21.5 °C  
Test Date: May.05, 2010

**DUT: U600; Type: Bar; Serial: #1**

Communication System: WiMAX 2600MHz FCC; Frequency: 2501 MHz; Duty Cycle: 1: 3.24  
Medium parameters used (interpolated):  $f = 2501$  MHz;  $\sigma = 2.06$  mho/m;  $\epsilon_r = 51.7$ ;  $\rho = 1000$  kg/m<sup>3</sup>  
Phantom section: Flat Section ; Measurement SW: DASY4, V4.7 Build 44; Postprocessing SW: SEMCAD, V1.8 Build 176

## DASY4 Configuration:

- Probe: ES3DV2 - SN3017; ConvF(3.78, 3.78, 3.78); Calibrated: 2009-07-22
- Sensor-Surface: 4mm (Mechanical Surface Detection)
- Electronics: DAE4 Sn869; Calibrated: 2009-09-18
- Phantom: SAM 1800/1900 MHz; Type: SAM

**WiMAX Body/Area Scan (41x61x1):** Measurement grid: dx=15mm, dy=15mm

[Info: Interpolated medium parameters used for SAR evaluation.](#)

Maximum value of SAR (interpolated) = 0.293 mW/g

**WiMAX Body/Zoom Scan (5x5x7)/Cube 0:** Measurement grid: dx=8mm, dy=8mm, dz=5mm

Reference Value = 11.1 V/m; Power Drift = -0.021 dB

Peak SAR (extrapolated) = 0.554 W/kg

**SAR(1 g) = 0.267 mW/g; SAR(10 g) = 0.134 mW/g**

[Info: Interpolated medium parameters used for SAR evaluation.](#)

Maximum value of SAR (measured) = 0.295 mW/g

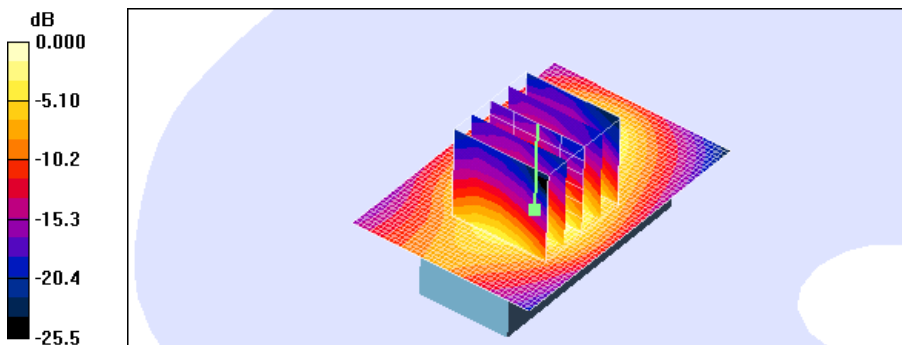

0 dB = 0.295mW/g

Test Laboratory: HCT CO., LTD  
EUT Type: USB Modem  
Liquid Temperature: 21.4 °C  
Ambient Temperature: 21.6 °C  
Test Date: Mar.26, 2010

**DUT: U600; Type: Bar; Serial: #1**

Communication System: WiMAX 10MHz; Frequency: 2593 MHz; Duty Cycle: 1:3.24  
Medium parameters used (interpolated):  $f = 2593$  MHz;  $\sigma = 2.17$  mho/m;  $\epsilon_r = 50.7$ ;  $\rho = 1000$  kg/m<sup>3</sup>  
Phantom section: Flat Section ; Measurement SW: DASY4, V4.7 Build 71; Postprocessing SW: SEMCAD, V1.8 Build 176

## DASY4 Configuration:

- Probe: ES3DV2 - SN3017; ConvF(3.78, 3.78, 3.78); Calibrated: 2009-07-22
- Sensor-Surface: 4mm (Mechanical Surface Detection)
- Electronics: DAE4 Sn869; Calibrated: 2009-09-18
- Phantom: SAM 1800/1900 MHz; Type: SAM

**WiMAX Body 2593/Area Scan (41x61x1):** Measurement grid: dx=15mm, dy=15mm

[Info: Interpolated medium parameters used for SAR evaluation.](#)

Maximum value of SAR (interpolated) = 0.673 mW/g

**WiMAX Body 2593/Zoom Scan (5x5x7)/Cube 0:** Measurement grid: dx=8mm, dy=8mm, dz=5mm

Reference Value = 14.3 V/m; Power Drift = -0.044 dB

Peak SAR (extrapolated) = 1.49 W/kg

**SAR(1 g) = 0.625 mW/g; SAR(10 g) = 0.266 mW/g**

[Info: Interpolated medium parameters used for SAR evaluation.](#)

Maximum value of SAR (measured) = 0.703 mW/g

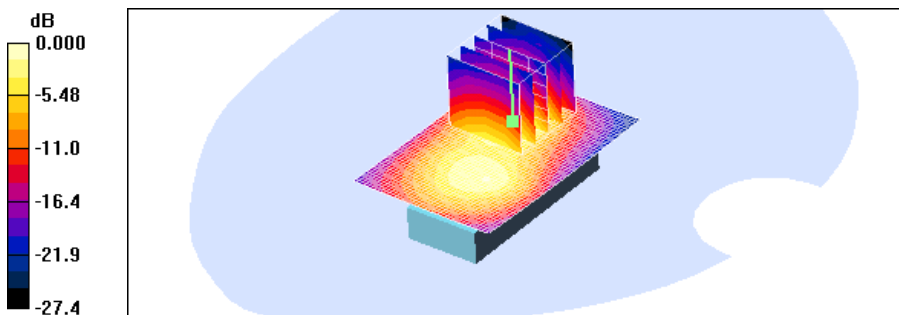

0 dB = 0.703mW/g

Test Laboratory: HCT CO., LTD  
EUT Type: USB Modem  
Liquid Temperature: 21.3 °C  
Ambient Temperature: 21.5 °C  
Test Date: May.05, 2010

**DUT: U600; Type: Bar; Serial: #1**

Communication System: WiMAX 2600MHz FCC; Frequency: 2685 MHz; Duty Cycle: 1: 3.24  
Medium parameters used (interpolated):  $f = 2685$  MHz;  $\sigma = 2.26$  mho/m;  $\epsilon_r = 51.1$ ;  $\rho = 1000$  kg/m<sup>3</sup>  
Phantom section: Flat Section ; Measurement SW: DASY4, V4.7 Build 44; Postprocessing SW: SEMCAD, V1.8 Build 176

## DASY4 Configuration:

- Probe: ES3DV2 - SN3017; ConvF(3.78, 3.78, 3.78); Calibrated: 2009-07-22
- Sensor-Surface: 4mm (Mechanical Surface Detection)
- Electronics: DAE4 Sn869; Calibrated: 2009-09-18
- Phantom: SAM 1800/1900 MHz; Type: SAM

**WiMAX Body/Area Scan (41x61x1):** Measurement grid: dx=15mm, dy=15mm

[Info: Interpolated medium parameters used for SAR evaluation.](#)

Maximum value of SAR (interpolated) = 0.320 mW/g

**WiMAX Body/Zoom Scan (5x5x7)/Cube 0:** Measurement grid: dx=8mm, dy=8mm, dz=5mm

Reference Value = 11.7 V/m; Power Drift = 0.016 dB

Peak SAR (extrapolated) = 0.847 W/kg

**SAR(1 g) = 0.313 mW/g; SAR(10 g) = 0.134 mW/g**

[Info: Interpolated medium parameters used for SAR evaluation.](#)

Maximum value of SAR (measured) = 0.320 mW/g

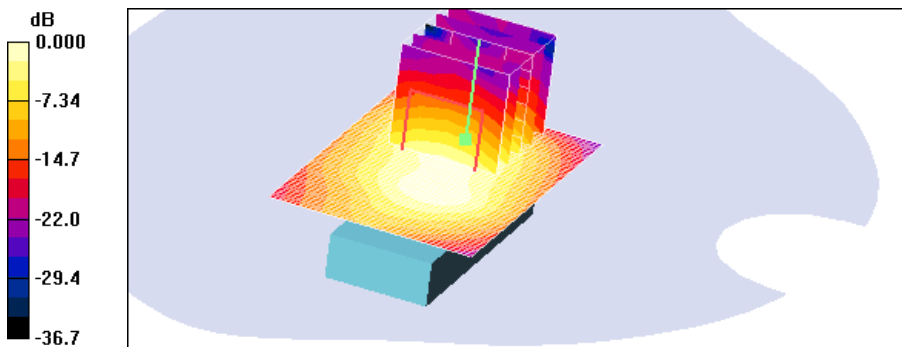

0 dB = 0.320mW/g



Test Laboratory: HCT CO., LTD  
EUT Type: USB Modem  
Liquid Temperature: 21.4 °C  
Ambient Temperature: 21.6 °C  
Test Date: Mar.26, 2010

**DUT: U600; Type: side; Serial: #1**

Communication System: WiMAX 10MHz; Frequency: 2593 MHz; Duty Cycle: 1:3.24  
Medium parameters used (interpolated):  $f = 2593$  MHz;  $\sigma = 2.17$  mho/m;  $\epsilon_r = 50.7$ ;  $\rho = 1000$  kg/m<sup>3</sup>  
Phantom section: Flat Section ; Measurement SW: DASY4, V4.7 Build 71; Postprocessing SW: SEMCAD, V1.8 Build 176

DASY4 Configuration:

- Probe: ES3DV2 - SN3017; ConvF(3.78, 3.78, 3.78); Calibrated: 2009-07-22
- Sensor-Surface: 4mm (Mechanical Surface Detection)
- Electronics: DAE4 Sn869; Calibrated: 2009-09-18
- Phantom: SAM 1800/1900 MHz; Type: SAM

**Wimax Body 2593/Area Scan (41x71x1):** Measurement grid: dx=15mm, dy=15mm

[Info: Interpolated medium parameters used for SAR evaluation.](#)

Maximum value of SAR (interpolated) = 0.449 mW/g

**Wimax Body 2593/Zoom Scan (5x5x7)/Cube 0:** Measurement grid: dx=8mm, dy=8mm, dz=5mm

Reference Value = 11.1 V/m; Power Drift = -0.02 dB

Peak SAR (extrapolated) = 1.29 W/kg

**SAR(1 g) = 0.419 mW/g; SAR(10 g) = 0.156 mW/g**

[Info: Interpolated medium parameters used for SAR evaluation.](#)

Maximum value of SAR (measured) = 0.481 mW/g

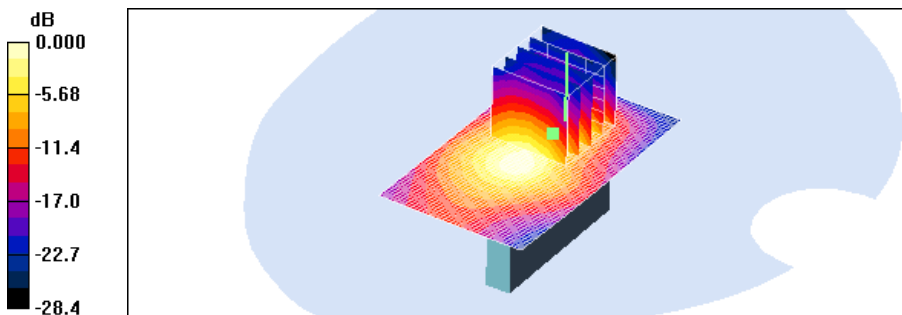

0 dB = 0.481mW/g

Test Laboratory: HCT CO., LTD  
EUT Type: USB Modem  
Liquid Temperature: 21.4 °C  
Ambient Temperature: 21.6 °C  
Test Date: Mar.26, 2010

**DUT: U600; Type: side; Serial: #1**

Communication System: WiMAX 10MHz; Frequency: 2593 MHz; Duty Cycle: 1:3.24  
Medium parameters used (interpolated):  $f = 2593$  MHz;  $\sigma = 2.17$  mho/m;  $\epsilon_r = 50.7$ ;  $\rho = 1000$  kg/m<sup>3</sup>  
Phantom section: Flat Section ; Measurement SW: DASY4, V4.7 Build 71; Postprocessing SW: SEMCAD, V1.8 Build 176

DASY4 Configuration:

- Probe: ES3DV2 - SN3017; ConvF(3.78, 3.78, 3.78); Calibrated: 2009-07-22
- Sensor-Surface: 4mm (Mechanical Surface Detection)
- Electronics: DAE4 Sn869; Calibrated: 2009-09-18
- Phantom: SAM 1800/1900 MHz; Type: SAM

**Wimax Body 2593/Area Scan (41x71x1):** Measurement grid: dx=15mm, dy=15mm

[Info: Interpolated medium parameters used for SAR evaluation.](#)

Maximum value of SAR (interpolated) = 0.147 mW/g

**Wimax Body 2593/Zoom Scan (5x5x7)/Cube 0:** Measurement grid: dx=8mm, dy=8mm, dz=5mm

Reference Value = 4.15 V/m; Power Drift = -0.012 dB

Peak SAR (extrapolated) = 0.300 W/kg

**SAR(1 g) = 0.131 mW/g; SAR(10 g) = 0.060 mW/g**

[Info: Interpolated medium parameters used for SAR evaluation.](#)

Maximum value of SAR (measured) = 0.146 mW/g

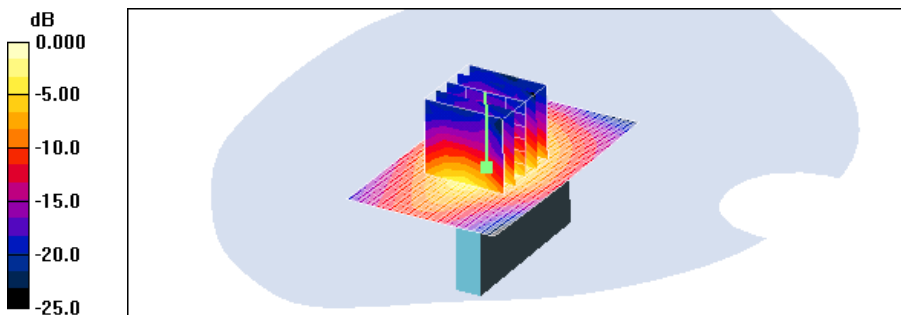

0 dB = 0.146mW/g

Test Laboratory: HCT CO., LTD  
EUT Type: USB Modem  
Liquid Temperature: 21.4 °C  
Ambient Temperature: 21.6 °C  
Test Date: Mar.26, 2010

**DUT: U600; Type: Bar; Serial: #1**

Communication System: WiMAX 10MHz; Frequency: 2593 MHz; Duty Cycle: 1:3.24  
Medium parameters used (interpolated):  $f = 2593$  MHz;  $\sigma = 2.17$  mho/m;  $\epsilon_r = 50.7$ ;  $\rho = 1000$  kg/m<sup>3</sup>  
Phantom section: Flat Section ; Measurement SW: DASY4, V4.7 Build 71; Postprocessing SW: SEMCAD, V1.8 Build 176

## DASY4 Configuration:

- Probe: ES3DV2 - SN3017; ConvF(3.78, 3.78, 3.78); Calibrated: 2009-07-22
- Sensor-Surface: 4mm (Mechanical Surface Detection)
- Electronics: DAE4 Sn869; Calibrated: 2009-09-18
- Phantom: SAM 1800/1900 MHz; Type: SAM

**Wimax Body 2593/Area Scan (51x51x1):** Measurement grid: dx=15mm, dy=15mm

[Info: Interpolated medium parameters used for SAR evaluation.](#)

Maximum value of SAR (interpolated) = 0.040 mW/g

**Wimax Body 2593/Zoom Scan (5x5x7)/Cube 0:** Measurement grid: dx=8mm, dy=8mm, dz=5mm

Reference Value = 3.71 V/m; Power Drift = 0.110 dB

Peak SAR (extrapolated) = 0.069 W/kg

**SAR(1 g) = 0.035 mW/g; SAR(10 g) = 0.017 mW/g**

[Info: Interpolated medium parameters used for SAR evaluation.](#)

Maximum value of SAR (measured) = 0.037 mW/g

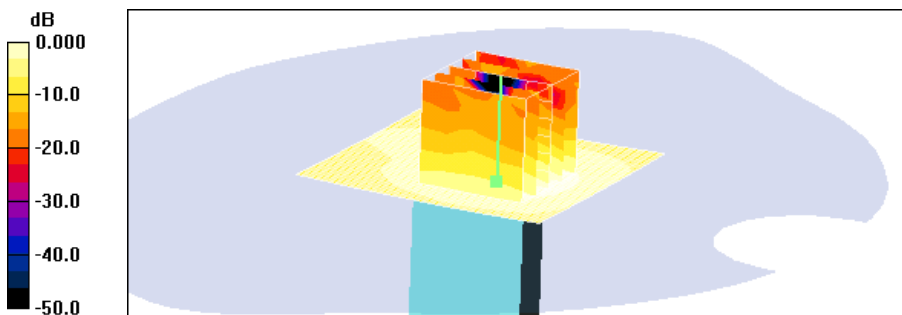

0 dB = 0.037mW/g

Test Laboratory: HCT CO., LTD  
EUT Type: USB Modem  
Liquid Temperature: 21.4 °C  
Ambient Temperature: 21.6 °C  
Test Date: Mar.26, 2010

**DUT: U600; Type: Bar; Serial: #1**

Communication System: WiMAX 10MHz; Frequency: 2593 MHz; Duty Cycle: 1:3.24  
Medium parameters used (interpolated):  $f = 2593$  MHz;  $\sigma = 2.17$  mho/m;  $\epsilon_r = 50.7$ ;  $\rho = 1000$  kg/m<sup>3</sup>  
Phantom section: Flat Section ; Measurement SW: DASY4, V4.7 Build 71; Postprocessing SW: SEMCAD, V1.8 Build 176

## DASY4 Configuration:

- Probe: ES3DV2 - SN3017; ConvF(3.78, 3.78, 3.78); Calibrated: 2009-07-22
- Sensor-Surface: 4mm (Mechanical Surface Detection)
- Electronics: DAE4 Sn869; Calibrated: 2009-09-18
- Phantom: SAM 1800/1900 MHz; Type: SAM

**WiMAX Body 2593/Area Scan (41x61x1):** Measurement grid: dx=15mm, dy=15mm

[Info: Interpolated medium parameters used for SAR evaluation.](#)

Maximum value of SAR (interpolated) = 0.285 mW/g

**WiMAX Body 2593/Zoom Scan (5x5x7)/Cube 0:** Measurement grid: dx=8mm, dy=8mm, dz=5mm

Reference Value = 8.15 V/m; Power Drift = -0.076 dB

Peak SAR (extrapolated) = 0.528 W/kg

**SAR(1 g) = 0.242 mW/g; SAR(10 g) = 0.115 mW/g**

[Info: Interpolated medium parameters used for SAR evaluation.](#)

Maximum value of SAR (measured) = 0.270 mW/g

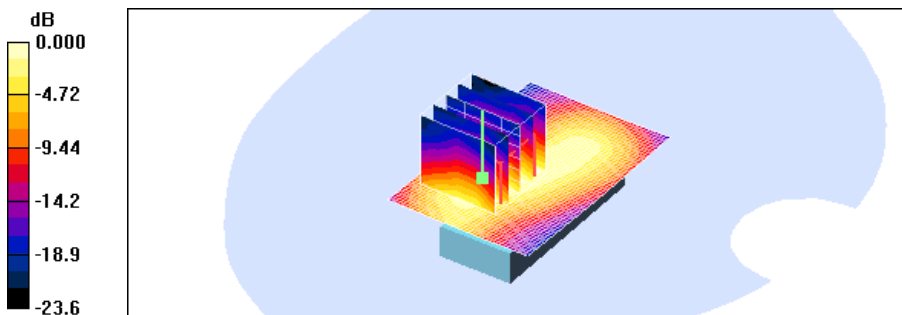

0 dB = 0.270mW/g

Test Laboratory: HCT CO., LTD  
EUT Type: USB Modem  
Liquid Temperature: 21.3 °C  
Ambient Temperature: 21.5 °C  
Test Date: May.05, 2010

**DUT: U600; Type: Bar; Serial: #1**

Communication System: WiMAX 2600MHz FCC; Frequency: 2501 MHz; Duty Cycle: 1: 3.24  
Medium parameters used (interpolated):  $f = 2501$  MHz;  $\sigma = 2.06$  mho/m;  $\epsilon_r = 51$ ;  $\rho = 1000$  kg/m<sup>3</sup>  
Phantom section: Flat Section ; Measurement SW: DASY4, V4.7 Build 44; Postprocessing SW: SEMCAD, V1.8 Build 176

## DASY4 Configuration:

- Probe: ES3DV2 - SN3017; ConvF(3.78, 3.78, 3.78); Calibrated: 2009-07-22
- Sensor-Surface: 4mm (Mechanical Surface Detection)
- Electronics: DAE4 Sn869; Calibrated: 2009-09-18
- Phantom: SAM 1800/1900 MHz; Type: SAM

**WiMAX Body/Area Scan (41x61x1):** Measurement grid: dx=15mm, dy=15mm[Info: Interpolated medium parameters used for SAR evaluation.](#)

Maximum value of SAR (interpolated) = 0.302 mW/g

**WiMAX Body/Zoom Scan (5x5x7)/Cube 0:** Measurement grid: dx=8mm, dy=8mm, dz=5mm

Reference Value = 11.3 V/m; Power Drift = 0.026 dB

Peak SAR (extrapolated) = 0.565 W/kg

**SAR(1 g) = 0.276 mW/g; SAR(10 g) = 0.138 mW/g**[Info: Interpolated medium parameters used for SAR evaluation.](#)

Maximum value of SAR (measured) = 0.305 mW/g

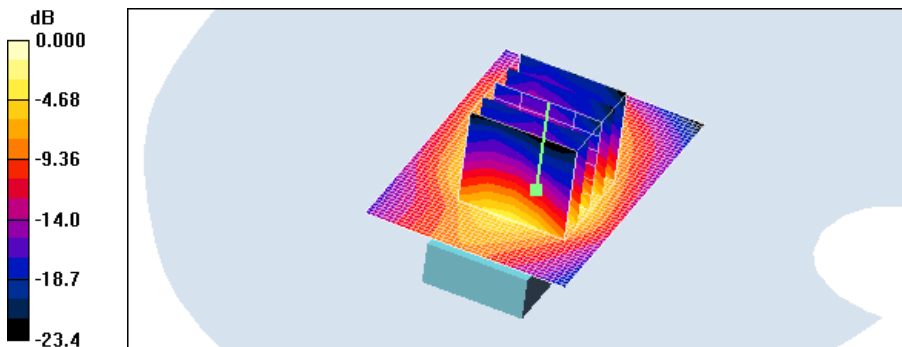

0 dB = 0.305mW/g

Test Laboratory: HCT CO., LTD  
EUT Type: USB Modem  
Liquid Temperature: 21.4 °C  
Ambient Temperature: 21.6 °C  
Test Date: Mar.26, 2010

**DUT: U600; Type: Bar; Serial: #1**

Communication System: WiMAX 10MHz; Frequency: 2593 MHz; Duty Cycle: 1:3.24  
Medium parameters used (interpolated):  $f = 2593$  MHz;  $\sigma = 2.17$  mho/m;  $\epsilon_r = 50.7$ ;  $\rho = 1000$  kg/m<sup>3</sup>  
Phantom section: Flat Section ; Measurement SW: DASY4, V4.7 Build 71; Postprocessing SW: SEMCAD, V1.8 Build 176

## DASY4 Configuration:

- Probe: ES3DV2 - SN3017; ConvF(3.78, 3.78, 3.78); Calibrated: 2009-07-22
- Sensor-Surface: 4mm (Mechanical Surface Detection)
- Electronics: DAE4 Sn869; Calibrated: 2009-09-18
- Phantom: SAM 1800/1900 MHz; Type: SAM

**WIMAX Body 2593/Area Scan (41x61x1):** Measurement grid: dx=15mm, dy=15mm

[Info: Interpolated medium parameters used for SAR evaluation.](#)

Maximum value of SAR (interpolated) = 0.671 mW/g

**WIMAX Body 2593/Zoom Scan (5x5x7)/Cube 0:** Measurement grid: dx=8mm, dy=8mm, dz=5mm

Reference Value = 13.7 V/m; Power Drift = -0.141 dB

Peak SAR (extrapolated) = 1.50 W/kg

**SAR(1 g) = 0.625 mW/g; SAR(10 g) = 0.266 mW/g**

[Info: Interpolated medium parameters used for SAR evaluation.](#)

Maximum value of SAR (measured) = 0.685 mW/g

**WIMAX Body 2593/Zoom Scan (5x5x7)/Cube 1:** Measurement grid: dx=8mm, dy=8mm, dz=5mm

Reference Value = 13.7 V/m; Power Drift = -0.141 dB

Peak SAR (extrapolated) = 0.984 W/kg

**SAR(1 g) = 0.483 mW/g; SAR(10 g) = 0.238 mW/g**

[Info: Interpolated medium parameters used for SAR evaluation.](#)

Maximum value of SAR (measured) = 0.529 mW/g

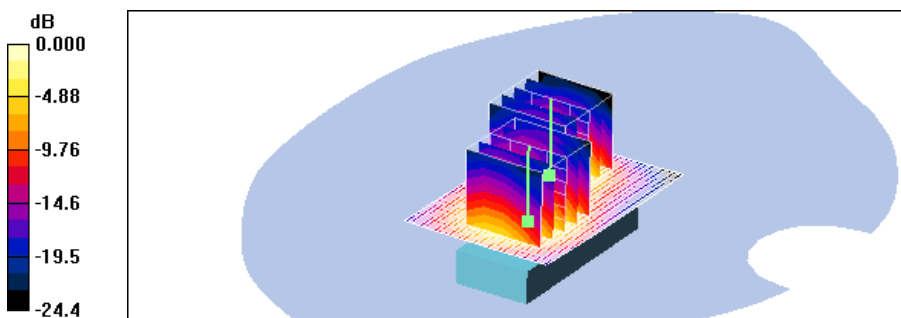

0 dB = 0.529mW/g

Test Laboratory: HCT CO., LTD  
EUT Type: USB Modem  
Liquid Temperature: 21.3 °C  
Ambient Temperature: 21.5 °C  
Test Date: May.05, 2010

**DUT: U600; Type: Bar; Serial: #1**

Communication System: WiMAX 2600MHz FCC; Frequency: 2685 MHz; Duty Cycle: 1: 3.24  
Medium parameters used (interpolated):  $f = 2685$  MHz;  $\sigma = 2.26$  mho/m;  $\epsilon_r = 51.1$ ;  $\rho = 1000$  kg/m<sup>3</sup>  
Phantom section: Flat Section ; Measurement SW: DASY4, V4.7 Build 44; Postprocessing SW: SEMCAD, V1.8 Build 176

## DASY4 Configuration:

- Probe: ES3DV2 - SN3017; ConvF(3.78, 3.78, 3.78); Calibrated: 2009-07-22
- Sensor-Surface: 4mm (Mechanical Surface Detection)
- Electronics: DAE4 Sn869; Calibrated: 2009-09-18
- Phantom: SAM 1800/1900 MHz; Type: SAM

**WiMAX Body/Area Scan (41x61x1):** Measurement grid: dx=15mm, dy=15mmInfo: [Interpolated medium parameters used for SAR evaluation.](#)

Maximum value of SAR (interpolated) = 0.314 mW/g

**WiMAX Body/Zoom Scan (5x5x7)/Cube 0:** Measurement grid: dx=8mm, dy=8mm, dz=5mm

Reference Value = 11.7 V/m; Power Drift = 0.002 dB

Peak SAR (extrapolated) = 0.842 W/kg

**SAR(1 g) = 0.309 mW/g; SAR(10 g) = 0.132 mW/g**

Maximum value of SAR (measured) = 0.321 mW/g

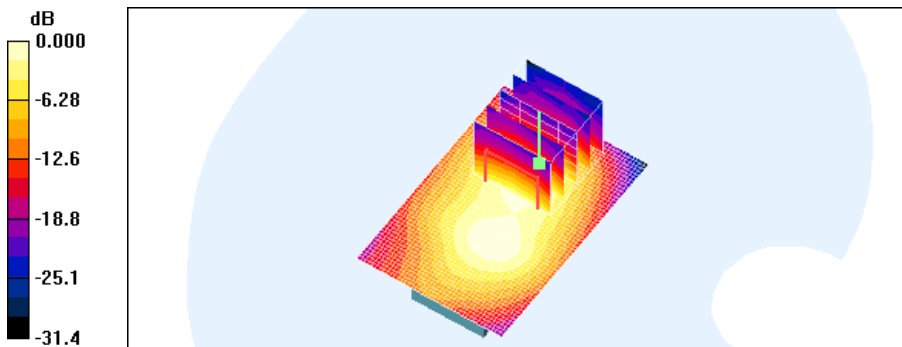

0 dB = 0.321mW/g

Test Laboratory: HCT CO., LTD  
EUT Type: USB Modem  
Liquid Temperature: 21.4 °C  
Ambient Temperature: 21.6 °C  
Test Date: Mar.26, 2010

**DUT: U600; Type: side; Serial: #1**

Communication System: WiMAX 10MHz; Frequency: 2593 MHz; Duty Cycle: 1:3.24  
Medium parameters used (interpolated):  $f = 2593$  MHz;  $\sigma = 2.17$  mho/m;  $\epsilon_r = 50.7$ ;  $\rho = 1000$  kg/m<sup>3</sup>  
Phantom section: Flat Section ; Measurement SW: DASY4, V4.7 Build 71; Postprocessing SW: SEMCAD, V1.8 Build 176

DASY4 Configuration:

- Probe: ES3DV2 - SN3017; ConvF(3.78, 3.78, 3.78); Calibrated: 2009-07-22
- Sensor-Surface: 4mm (Mechanical Surface Detection)
- Electronics: DAE4 Sn869; Calibrated: 2009-09-18
- Phantom: SAM 1800/1900 MHz; Type: SAM

**Wimax Body 2593/Area Scan (41x71x1):** Measurement grid: dx=15mm, dy=15mm

[Info: Interpolated medium parameters used for SAR evaluation.](#)

Maximum value of SAR (interpolated) = 0.460 mW/g

**Wimax Body 2593/Zoom Scan (5x5x7)/Cube 0:** Measurement grid: dx=8mm, dy=8mm, dz=5mm

Reference Value = 11.5 V/m; Power Drift = -0.020 dB

Peak SAR (extrapolated) = 1.27 W/kg

**SAR(1 g) = 0.420 mW/g; SAR(10 g) = 0.156 mW/g**

[Info: Interpolated medium parameters used for SAR evaluation.](#)

Maximum value of SAR (measured) = 0.472 mW/g

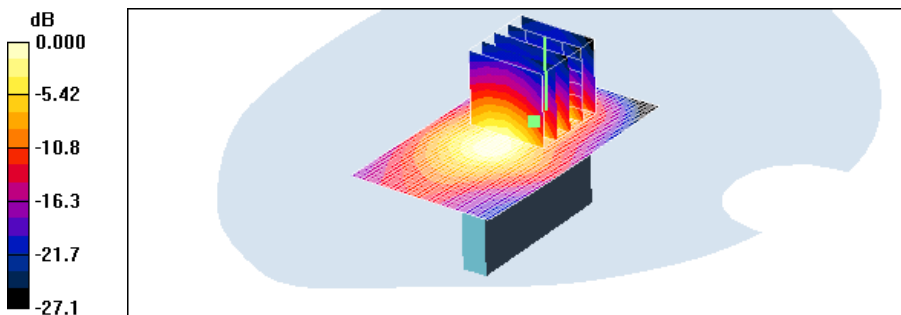

0 dB = 0.472mW/g



Test Laboratory: HCT CO., LTD  
EUT Type: USB Modem  
Liquid Temperature: 21.4 °C  
Ambient Temperature: 21.6 °C  
Test Date: Mar.26, 2010

**DUT: U600; Type: side; Serial: #1**

Communication System: WiMAX 10MHz; Frequency: 2593 MHz; Duty Cycle: 1:3.24  
Medium parameters used (interpolated):  $f = 2593$  MHz;  $\sigma = 2.17$  mho/m;  $\epsilon_r = 50.7$ ;  $\rho = 1000$  kg/m<sup>3</sup>  
Phantom section: Flat Section ; Measurement SW: DASY4, V4.7 Build 71; Postprocessing SW: SEMCAD, V1.8 Build 176

DASY4 Configuration:

- Probe: ES3DV2 - SN3017; ConvF(3.78, 3.78, 3.78); Calibrated: 2009-07-22
- Sensor-Surface: 4mm (Mechanical Surface Detection)
- Electronics: DAE4 Sn869; Calibrated: 2009-09-18
- Phantom: SAM 1800/1900 MHz; Type: SAM

**Wimax Body 2593/Area Scan (41x71x1):** Measurement grid: dx=15mm, dy=15mm

[Info: Interpolated medium parameters used for SAR evaluation.](#)

Maximum value of SAR (interpolated) = 0.151 mW/g

**Wimax Body 2593/Zoom Scan (5x5x7)/Cube 0:** Measurement grid: dx=8mm, dy=8mm, dz=5mm

Reference Value = 4.24 V/m; Power Drift = -0.063 dB

Peak SAR (extrapolated) = 0.293 W/kg

**SAR(1 g) = 0.131 mW/g; SAR(10 g) = 0.060 mW/g**

[Info: Interpolated medium parameters used for SAR evaluation.](#)

Maximum value of SAR (measured) = 0.145 mW/g

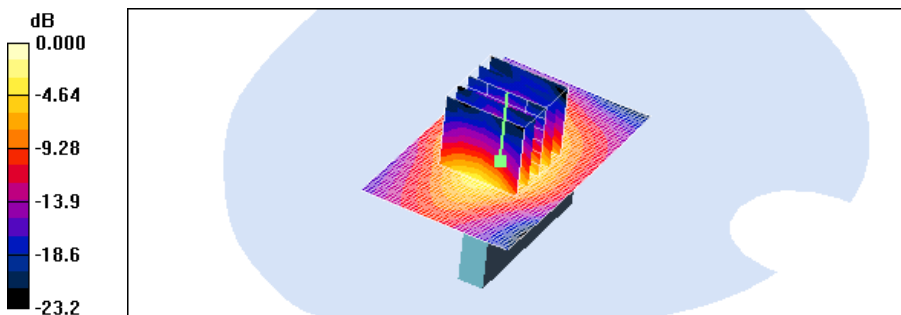

0 dB = 0.145mW/g

Test Laboratory: HCT CO., LTD  
EUT Type: USB Modem  
Liquid Temperature: 21.4 °C  
Ambient Temperature: 21.6 °C  
Test Date: Mar.26, 2010

**DUT: U600; Type: Bar; Serial: #1**

Communication System: WiMAX 10MHz; Frequency: 2593 MHz; Duty Cycle: 1:3.24  
Medium parameters used (interpolated):  $f = 2593$  MHz;  $\sigma = 2.17$  mho/m;  $\epsilon_r = 50.7$ ;  $\rho = 1000$  kg/m<sup>3</sup>  
Phantom section: Flat Section ; Measurement SW: DASY4, V4.7 Build 71; Postprocessing SW: SEMCAD, V1.8 Build 176

## DASY4 Configuration:

- Probe: ES3DV2 - SN3017; ConvF(3.78, 3.78, 3.78); Calibrated: 2009-07-22
- Sensor-Surface: 4mm (Mechanical Surface Detection)
- Electronics: DAE4 Sn869; Calibrated: 2009-09-18
- Phantom: SAM 1800/1900 MHz; Type: SAM

**Wimax Body 2593/Area Scan (51x51x1):** Measurement grid: dx=15mm, dy=15mm

[Info: Interpolated medium parameters used for SAR evaluation.](#)

Maximum value of SAR (interpolated) = 0.041 mW/g

**Wimax Body 2593/Zoom Scan (5x5x7)/Cube 0:** Measurement grid: dx=8mm, dy=8mm, dz=5mm

Reference Value = 3.82 V/m; Power Drift = -0.096 dB

Peak SAR (extrapolated) = 0.075 W/kg

**SAR(1 g) = 0.036 mW/g; SAR(10 g) = 0.017 mW/g**

[Info: Interpolated medium parameters used for SAR evaluation.](#)

Maximum value of SAR (measured) = 0.039 mW/g

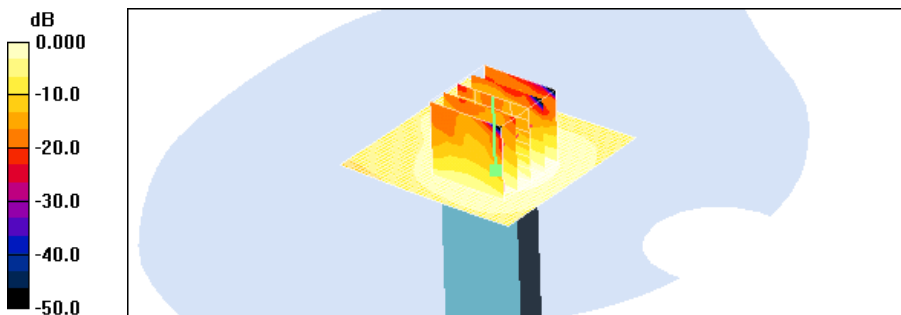

0 dB = 0.039mW/g

Test Laboratory: HCT CO., LTD  
EUT Type: USB Modem  
Liquid Temperature: 21.4 °C  
Ambient Temperature: 21.6 °C  
Test Date: Mar.26, 2010

**DUT: U600; Type: Bar; Serial: #1**

Communication System: WiMAX 10MHz; Frequency: 2593 MHz; Duty Cycle: 1:3.24  
Medium parameters used (interpolated):  $f = 2593$  MHz;  $\sigma = 2.17$  mho/m;  $\epsilon_r = 50.7$ ;  $\rho = 1000$  kg/m<sup>3</sup>  
Phantom section: Flat Section ; Measurement SW: DASY4, V4.7 Build 71; Postprocessing SW: SEMCAD, V1.8 Build 176

## DASY4 Configuration:

- Probe: ES3DV2 - SN3017; ConvF(3.78, 3.78, 3.78); Calibrated: 2009-07-22
- Sensor-Surface: 4mm (Mechanical Surface Detection)
- Electronics: DAE4 Sn869; Calibrated: 2009-09-18
- Phantom: SAM 1800/1900 MHz; Type: SAM

**WiMAX Body 2593/Area Scan (41x61x1):** Measurement grid: dx=15mm, dy=15mm

[Info: Interpolated medium parameters used for SAR evaluation.](#)

Maximum value of SAR (interpolated) = 0.258 mW/g

**WiMAX Body 2593/Zoom Scan (5x5x7)/Cube 0:** Measurement grid: dx=8mm, dy=8mm, dz=5mm

Reference Value = 7.92 V/m; Power Drift = -0.130 dB

Peak SAR (extrapolated) = 0.500 W/kg

**SAR(1 g) = 0.229 mW/g; SAR(10 g) = 0.110 mW/g**

[Info: Interpolated medium parameters used for SAR evaluation.](#)

Maximum value of SAR (measured) = 0.250 mW/g

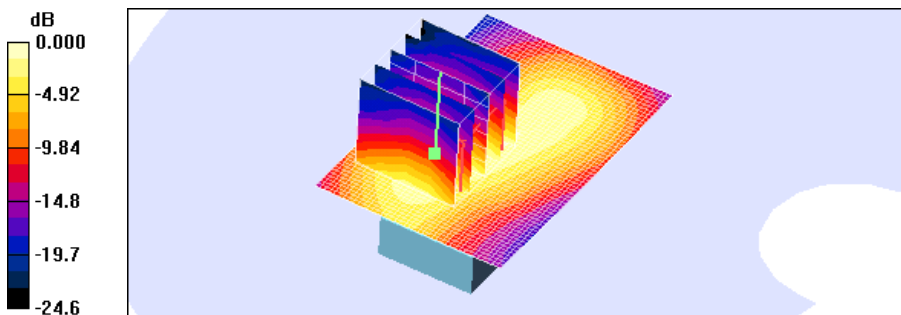

0 dB = 0.250mW/g

Test Laboratory: HCT CO., LTD  
EUT Type: USB Modem  
Liquid Temperature: 21.3 °C  
Ambient Temperature: 21.5 °C  
Test Date: May.05, 2010

**DUT: U600; Type: Bar; Serial: #1**

Communication System: WiMAX 2600MHz FCC; Frequency: 2501 MHz; Duty Cycle: 1: 3.24  
Medium parameters used (interpolated):  $f = 2501$  MHz;  $\sigma = 2.06$  mho/m;  $\epsilon_r = 51.7$ ;  $\rho = 1000$  kg/m<sup>3</sup>  
Phantom section: Flat Section ; Measurement SW: DASY4, V4.7 Build 44; Postprocessing SW: SEMCAD, V1.8 Build 176

## DASY4 Configuration:

- Probe: ES3DV2 - SN3017; ConvF(3.78, 3.78, 3.78); Calibrated: 2009-07-22
- Sensor-Surface: 4mm (Mechanical Surface Detection)
- Electronics: DAE4 Sn869; Calibrated: 2009-09-18
- Phantom: SAM 1800/1900 MHz; Type: SAM

**WiMAX Body/Area Scan (41x61x1):** Measurement grid: dx=15mm, dy=15mm[Info: Interpolated medium parameters used for SAR evaluation.](#)

Maximum value of SAR (interpolated) = 0.314 mW/g

**WiMAX Body/Zoom Scan (5x5x7)/Cube 0:** Measurement grid: dx=8mm, dy=8mm, dz=5mm

Reference Value = 11.1 V/m; Power Drift = 0.041 dB

Peak SAR (extrapolated) = 0.575 W/kg

**SAR(1 g) = 0.280 mW/g; SAR(10 g) = 0.140 mW/g**[Info: Interpolated medium parameters used for SAR evaluation.](#)

Maximum value of SAR (measured) = 0.311 mW/g

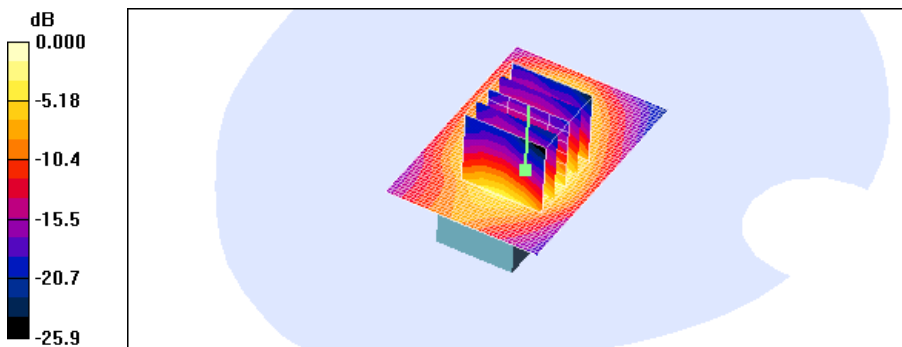

0 dB = 0.311mW/g

Test Laboratory: HCT CO., LTD  
EUT Type: USB Modem  
Liquid Temperature: 21.4 °C  
Ambient Temperature: 21.6 °C  
Test Date: Mar.26, 2010

**DUT: U600; Type: Bar; Serial: #1**

Communication System: WiMAX 10MHz; Frequency: 2593 MHz; Duty Cycle: 1:3.24  
Medium parameters used (interpolated):  $f = 2593$  MHz;  $\sigma = 2.17$  mho/m;  $\epsilon_r = 50.7$ ;  $\rho = 1000$  kg/m<sup>3</sup>  
Phantom section: Flat Section ; Measurement SW: DASY4, V4.7 Build 71; Postprocessing SW: SEMCAD, V1.8 Build 176

## DASY4 Configuration:

- Probe: ES3DV2 - SN3017; ConvF(3.78, 3.78, 3.78); Calibrated: 2009-07-22
- Sensor-Surface: 4mm (Mechanical Surface Detection)
- Electronics: DAE4 Sn869; Calibrated: 2009-09-18
- Phantom: SAM 1800/1900 MHz; Type: SAM

**WIMAX Body 2593/Area Scan (41x61x1):** Measurement grid: dx=15mm, dy=15mm

[Info: Interpolated medium parameters used for SAR evaluation.](#)

Maximum value of SAR (interpolated) = 0.679 mW/g

**WIMAX Body 2593/Zoom Scan (5x5x7)/Cube 0:** Measurement grid: dx=8mm, dy=8mm, dz=5mm

Reference Value = 14.0 V/m; Power Drift = -0.004 dB

Peak SAR (extrapolated) = 1.48 W/kg

**SAR(1 g) = 0.618 mW/g; SAR(10 g) = 0.262 mW/g**

[Info: Interpolated medium parameters used for SAR evaluation.](#)

Maximum value of SAR (measured) = 0.675 mW/g

**WIMAX Body 2593/Zoom Scan (5x5x7)/Cube 1:** Measurement grid: dx=8mm, dy=8mm, dz=5mm

Reference Value = 14.0 V/m; Power Drift = -0.004 dB

Peak SAR (extrapolated) = 0.950 W/kg

**SAR(1 g) = 0.473 mW/g; SAR(10 g) = 0.235 mW/g**

[Info: Interpolated medium parameters used for SAR evaluation.](#)

Maximum value of SAR (measured) = 0.519 mW/g

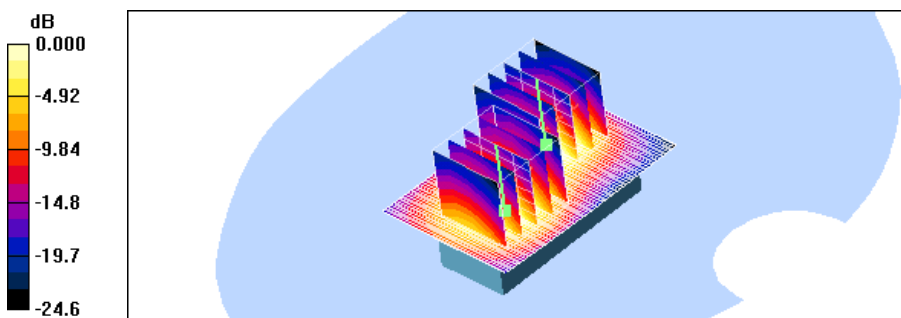

0 dB = 0.519mW/g

Test Laboratory: HCT CO., LTD  
EUT Type: USB Modem  
Liquid Temperature: 21.3 °C  
Ambient Temperature: 21.5 °C  
Test Date: May.05, 2010

**DUT: U600; Type: Bar; Serial: #1**

Communication System: WiMAX 2600MHz FCC; Frequency: 2685 MHz; Duty Cycle: 1: 3.24  
Medium parameters used (interpolated):  $f = 2685$  MHz;  $\sigma = 2.26$  mho/m;  $\epsilon_r = 51.1$ ;  $\rho = 1000$  kg/m<sup>3</sup>  
Phantom section: Flat Section ; Measurement SW: DASY4, V4.7 Build 44; Postprocessing SW: SEMCAD, V1.8 Build 176

## DASY4 Configuration:

- Probe: ES3DV2 - SN3017; ConvF(3.78, 3.78, 3.78); Calibrated: 2009-07-22
- Sensor-Surface: 4mm (Mechanical Surface Detection)
- Electronics: DAE4 Sn869; Calibrated: 2009-09-18
- Phantom: SAM 1800/1900 MHz; Type: SAM

**WiMAX Body/Area Scan (41x61x1):** Measurement grid: dx=15mm, dy=15mm

[Info: Interpolated medium parameters used for SAR evaluation.](#)

Maximum value of SAR (interpolated) = 0.359 mW/g

**WiMAX Body/Zoom Scan (5x5x7)/Cube 0:** Measurement grid: dx=8mm, dy=8mm, dz=5mm

Reference Value = 12.5 V/m; Power Drift = -0.153 dB

Peak SAR (extrapolated) = 0.914 W/kg

**SAR(1 g) = 0.333 mW/g; SAR(10 g) = 0.142 mW/g**

Maximum value of SAR (measured) = 0.343 mW/g

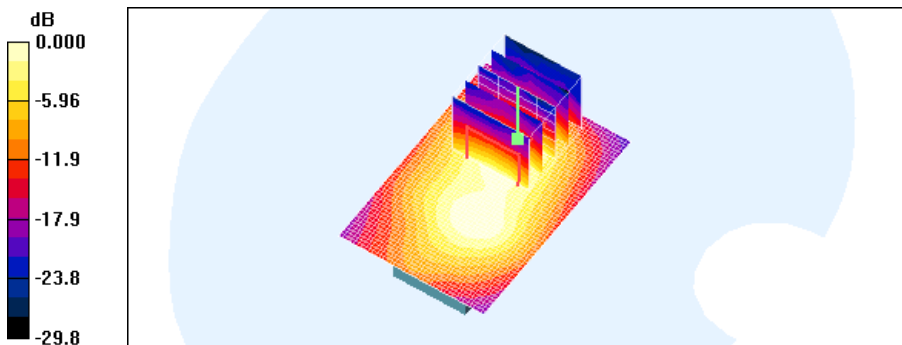

0 dB = 0.343mW/g

Test Laboratory: HCT CO., LTD  
EUT Type: USB Modem  
Liquid Temperature: 21.4 °C  
Ambient Temperature: 21.6 °C  
Test Date: Mar.26, 2010

**DUT: U600; Type: side; Serial: #1**

Communication System: WiMAX 10MHz; Frequency: 2593 MHz; Duty Cycle: 1:3.24  
Medium parameters used (interpolated):  $f = 2593$  MHz;  $\sigma = 2.17$  mho/m;  $\epsilon_r = 50.7$ ;  $\rho = 1000$  kg/m<sup>3</sup>  
Phantom section: Flat Section ; Measurement SW: DASY4, V4.7 Build 71; Postprocessing SW: SEMCAD, V1.8 Build 176

DASY4 Configuration:

- Probe: ES3DV2 - SN3017; ConvF(3.78, 3.78, 3.78); Calibrated: 2009-07-22
- Sensor-Surface: 4mm (Mechanical Surface Detection)
- Electronics: DAE4 Sn869; Calibrated: 2009-09-18
- Phantom: SAM 1800/1900 MHz; Type: SAM

**Wimax Body 2593/Area Scan (41x71x1):** Measurement grid: dx=15mm, dy=15mm

[Info: Interpolated medium parameters used for SAR evaluation.](#)

Maximum value of SAR (interpolated) = 0.472 mW/g

**Wimax Body 2593/Zoom Scan (5x5x7)/Cube 0:** Measurement grid: dx=8mm, dy=8mm, dz=5mm

Reference Value = 10.5 V/m; Power Drift = 0.011 dB

Peak SAR (extrapolated) = 1.25 W/kg

**SAR(1 g) = 0.420 mW/g; SAR(10 g) = 0.157 mW/g**

[Info: Interpolated medium parameters used for SAR evaluation.](#)

Maximum value of SAR (measured) = 0.476 mW/g

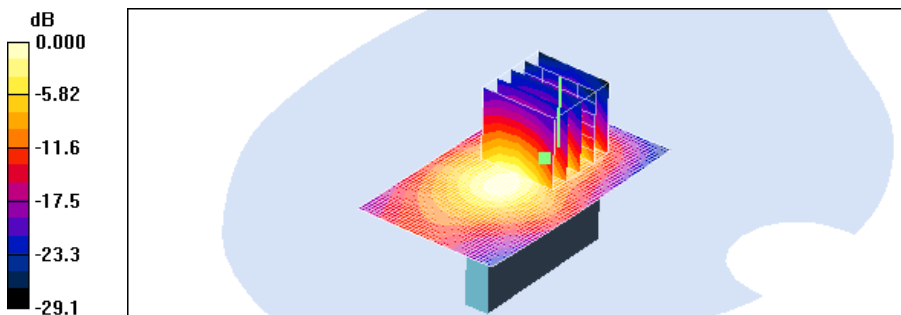

0 dB = 0.476mW/g

Test Laboratory: HCT CO., LTD  
EUT Type: USB Modem  
Liquid Temperature: 21.4 °C  
Ambient Temperature: 21.6 °C  
Test Date: Mar.26, 2010

**DUT: U600; Type: side; Serial: #1**

Communication System: WiMAX 10MHz; Frequency: 2593 MHz; Duty Cycle: 1:3.24  
Medium parameters used (interpolated):  $f = 2593$  MHz;  $\sigma = 2.17$  mho/m;  $\epsilon_r = 50.7$ ;  $\rho = 1000$  kg/m<sup>3</sup>  
Phantom section: Flat Section ; Measurement SW: DASY4, V4.7 Build 71; Postprocessing SW: SEMCAD, V1.8 Build 176

## DASY4 Configuration:

- Probe: ES3DV2 - SN3017; ConvF(3.78, 3.78, 3.78); Calibrated: 2009-07-22
- Sensor-Surface: 4mm (Mechanical Surface Detection)
- Electronics: DAE4 Sn869; Calibrated: 2009-09-18
- Phantom: SAM 1800/1900 MHz; Type: SAM

**Wimax Body 2593/Area Scan (41x71x1):** Measurement grid: dx=15mm, dy=15mm

[Info: Interpolated medium parameters used for SAR evaluation.](#)

Maximum value of SAR (interpolated) = 0.148 mW/g

**Wimax Body 2593/Zoom Scan (5x5x7)/Cube 0:** Measurement grid: dx=8mm, dy=8mm, dz=5mm

Reference Value = 4.23 V/m; Power Drift = -0.006 dB

Peak SAR (extrapolated) = 0.295 W/kg

**SAR(1 g) = 0.133 mW/g; SAR(10 g) = 0.061 mW/g**

[Info: Interpolated medium parameters used for SAR evaluation.](#)

Maximum value of SAR (measured) = 0.149 mW/g

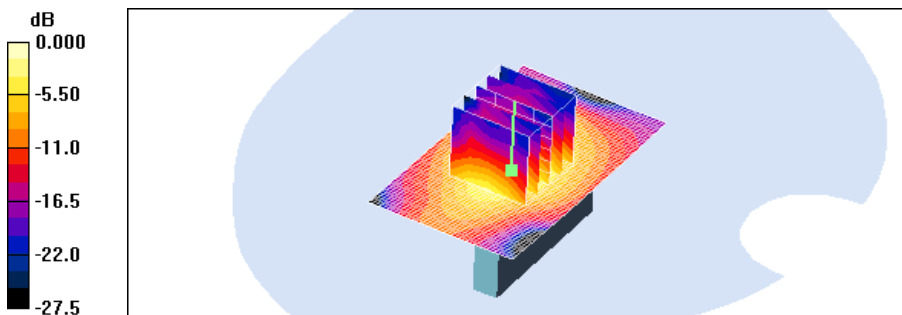

0 dB = 0.149mW/g



Test Laboratory: HCT CO., LTD  
EUT Type: USB Modem  
Liquid Temperature: 21.4 °C  
Ambient Temperature: 21.6 °C  
Test Date: Mar.26, 2010

**DUT: U600; Type: Bar; Serial: #1**

Communication System: WiMAX 10MHz; Frequency: 2593 MHz; Duty Cycle: 1:3.24  
Medium parameters used (interpolated):  $f = 2593$  MHz;  $\sigma = 2.17$  mho/m;  $\epsilon_r = 50.7$ ;  $\rho = 1000$  kg/m<sup>3</sup>  
Phantom section: Flat Section ; Measurement SW: DASY4, V4.7 Build 71; Postprocessing SW: SEMCAD, V1.8 Build 176

## DASY4 Configuration:

- Probe: ES3DV2 - SN3017; ConvF(3.78, 3.78, 3.78); Calibrated: 2009-07-22
- Sensor-Surface: 4mm (Mechanical Surface Detection)
- Electronics: DAE4 Sn869; Calibrated: 2009-09-18
- Phantom: SAM 1800/1900 MHz; Type: SAM

**Wimax Body 2593/Area Scan (51x51x1):** Measurement grid: dx=15mm, dy=15mm

[Info: Interpolated medium parameters used for SAR evaluation.](#)

Maximum value of SAR (interpolated) = 0.042 mW/g

**Wimax Body 2593/Zoom Scan (5x5x7)/Cube 0:** Measurement grid: dx=8mm, dy=8mm, dz=5mm

Reference Value = 3.83 V/m; Power Drift = -0.067 dB

Peak SAR (extrapolated) = 0.074 W/kg

**SAR(1 g) = 0.037 mW/g; SAR(10 g) = 0.017 mW/g**

[Info: Interpolated medium parameters used for SAR evaluation.](#)

Maximum value of SAR (measured) = 0.040 mW/g

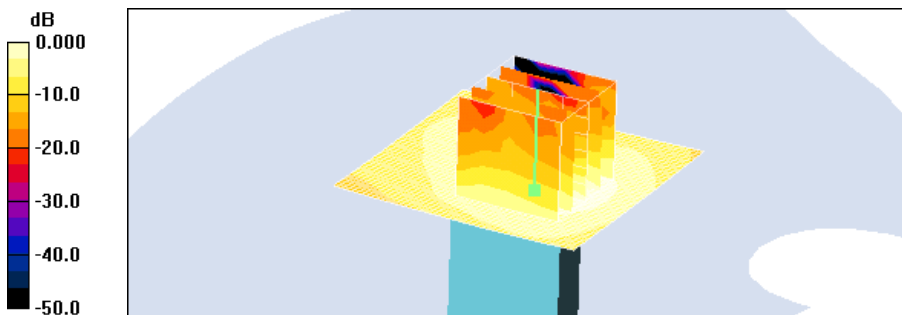

Test Laboratory: HCT CO., LTD  
EUT Type: USB Modem  
Liquid Temperature: 21.4 °C  
Ambient Temperature: 21.6 °C  
Test Date: Mar.26, 2010

**DUT: U600; Type: Bar; Serial: #1**

Communication System: WiMAX ; Frequency: 2593 MHz; Duty Cycle: 1:3.24  
Medium parameters used (interpolated):  $f = 2593$  MHz;  $\sigma = 2.17$  mho/m;  $\epsilon_r = 50.7$ ;  $\rho = 1000$  kg/m<sup>3</sup>  
Phantom section: Flat Section ; Measurement SW: DASY4, V4.7 Build 44; Postprocessing SW: SEMCAD, V1.8 Build 176

DASY4 Configuration:

- Probe: ES3DV2 - SN3017; ConvF(3.78, 3.78, 3.78); Calibrated: 2009-07-22
- Sensor-Surface: 4mm (Mechanical Surface Detection)
- Electronics: DAE4 Sn869; Calibrated: 2009-09-18
- Phantom: SAM 835/1900 MHz; Type: SAM

**WiMAX Body/Area Scan (41x61x1):** Measurement grid: dx=15mm, dy=15mm

[Info: Interpolated medium parameters used for SAR evaluation.](#)

Maximum value of SAR (interpolated) = 0.087 mW/g

**WiMAX Body/Zoom Scan (5x5x7)/Cube 0:** Measurement grid: dx=8mm, dy=8mm, dz=5mm

Reference Value = 2.50 V/m; Power Drift = 0.098 dB

Peak SAR (extrapolated) = 0.204 W/kg

**SAR(1 g) = 0.076 mW/g; SAR(10 g) = 0.028 mW/g**

[Info: Interpolated medium parameters used for SAR evaluation.](#)

Maximum value of SAR (measured) = 0.083 mW/g

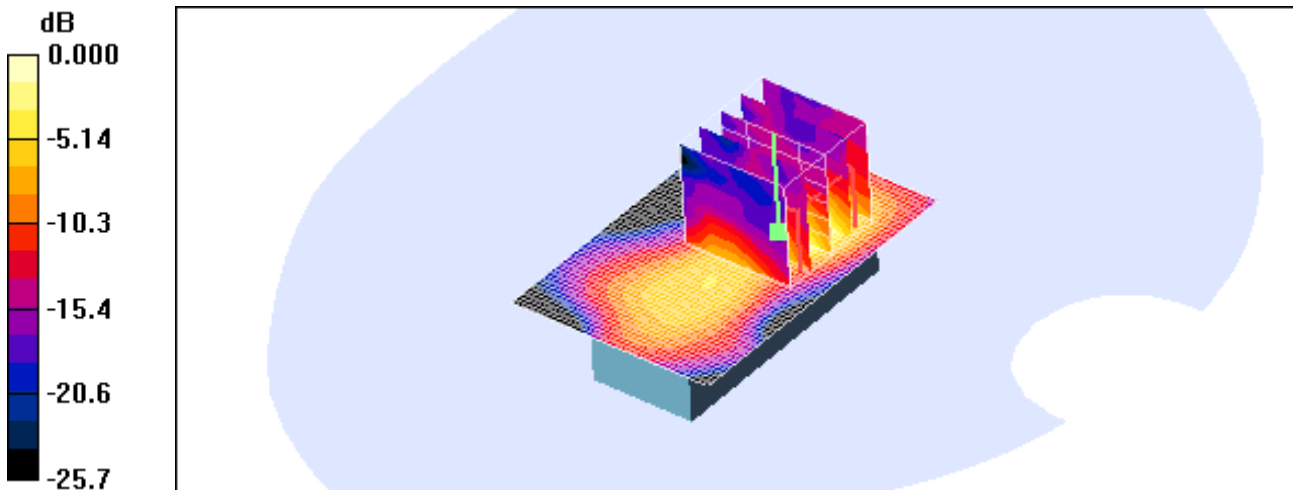

0 dB = 0.083mW/g

Test Laboratory: HCT CO., LTD  
EUT Type: USB Modem  
Liquid Temperature: 21.4 °C  
Ambient Temperature: 21.6 °C  
Test Date: Mar.26, 2010

**DUT: U600; Type: Bar; Serial: #1**

Communication System: WiMAX ; Frequency: 2593 MHz; Duty Cycle: 1:3.24  
Medium parameters used (interpolated):  $f = 2593$  MHz;  $\sigma = 2.17$  mho/m;  $\epsilon_r = 50.7$ ;  $\rho = 1000$  kg/m<sup>3</sup>  
Phantom section: Flat Section ; Measurement SW: DASY4, V4.7 Build 44; Postprocessing SW: SEMCAD, V1.8 Build 176

DASY4 Configuration:

- Probe: ES3DV2 - SN3017; ConvF(3.78, 3.78, 3.78); Calibrated: 2009-07-22
- Sensor-Surface: 4mm (Mechanical Surface Detection)
- Electronics: DAE4 Sn869; Calibrated: 2009-09-18
- Phantom: SAM 835/1900 MHz; Type: SAM

**WiMAX Body/Area Scan (41x61x1):** Measurement grid: dx=15mm, dy=15mm

[Info: Interpolated medium parameters used for SAR evaluation.](#)

Maximum value of SAR (interpolated) = 0.081 mW/g

**WiMAX Body/Zoom Scan (5x5x7)/Cube 0:** Measurement grid: dx=8mm, dy=8mm, dz=5mm

Reference Value = 3.72 V/m; Power Drift = 0.003 dB

Peak SAR (extrapolated) = 0.224 W/kg

**SAR(1 g) = 0.078 mW/g; SAR(10 g) = 0.029 mW/g**

[Info: Interpolated medium parameters used for SAR evaluation.](#)

Maximum value of SAR (measured) = 0.083 mW/g

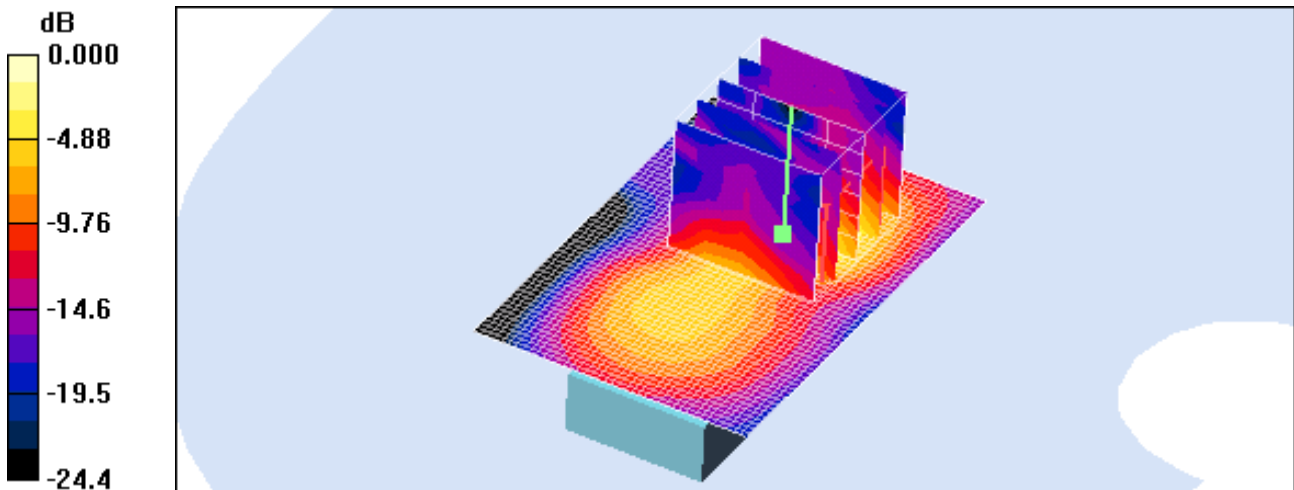

Test Laboratory: HCT CO., LTD  
EUT Type: USB Modem  
Liquid Temperature: 21.4 °C  
Ambient Temperature: 21.6 °C  
Test Date: Mar.26, 2010

**DUT: U600; Type: Bar; Serial: #1**

Communication System: WiMAX ; Frequency: 2593 MHz; Duty Cycle: 1:3.24  
Medium parameters used (interpolated):  $f = 2593$  MHz;  $\sigma = 2.17$  mho/m;  $\epsilon_r = 50.7$ ;  $\rho = 1000$  kg/m<sup>3</sup>  
Phantom section: Flat Section ; Measurement SW: DASY4, V4.7 Build 44; Postprocessing SW: SEMCAD, V1.8 Build 176

DASY4 Configuration:

- Probe: ES3DV2 - SN3017; ConvF(3.78, 3.78, 3.78); Calibrated: 2009-07-22
- Sensor-Surface: 4mm (Mechanical Surface Detection)
- Electronics: DAE4 Sn869; Calibrated: 2009-09-18
- Phantom: SAM 835/1900 MHz; Type: SAM

**WiMAX Body/Area Scan (41x61x1):** Measurement grid: dx=15mm, dy=15mm

[Info: Interpolated medium parameters used for SAR evaluation.](#)

Maximum value of SAR (interpolated) = 0.086 mW/g

**WiMAX Body/Zoom Scan (5x5x7)/Cube 0:** Measurement grid: dx=8mm, dy=8mm, dz=5mm

Reference Value = 2.74 V/m; Power Drift = -0.017 dB

Peak SAR (extrapolated) = 0.213 W/kg

**SAR(1 g) = 0.076 mW/g; SAR(10 g) = 0.028 mW/g**

[Info: Interpolated medium parameters used for SAR evaluation.](#)

Maximum value of SAR (measured) = 0.088 mW/g

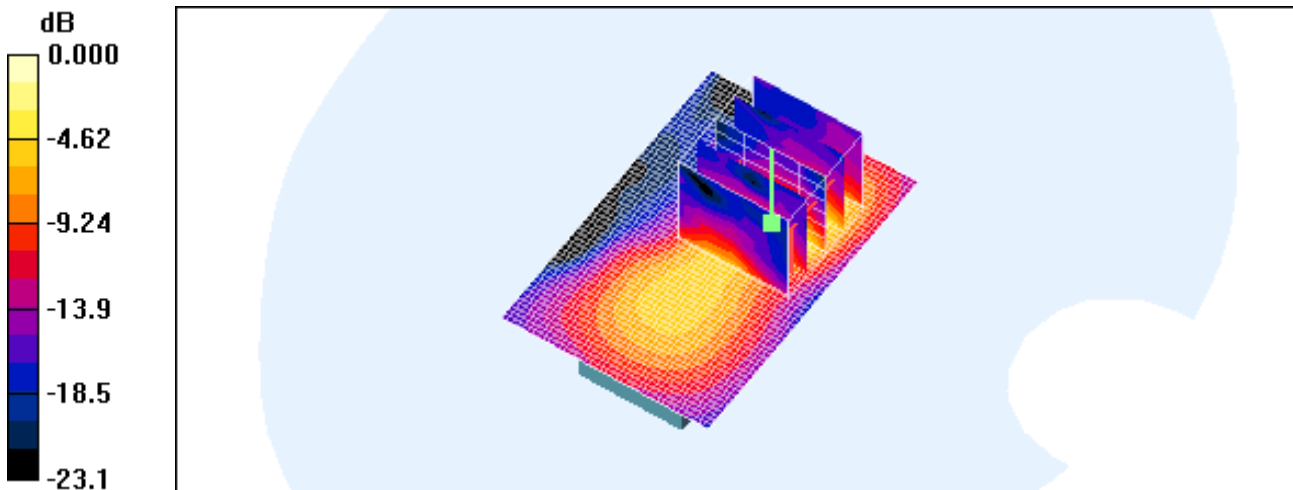

0 dB = 0.088mW/g

Test Laboratory: HCT CO., LTD  
EUT Type: USB Modem  
Liquid Temperature: 21.4 °C  
Ambient Temperature: 21.6 °C  
Test Date: Mar.26, 2010

**DUT: U600; Type: Bar; Serial: #1**

Communication System: WiMAX ; Frequency: 2593 MHz;Duty Cycle: 1:3.24  
Medium parameters used (interpolated):  $f = 2593$  MHz;  $\sigma = 2.17$  mho/m;  $\epsilon_r = 50.7$ ;  $\rho = 1000$  kg/m<sup>3</sup>  
Phantom section: Flat Section ; Measurement SW: DASY4, V4.7 Build 44; Postprocessing SW: SEMCAD, V1.8 Build 176

DASY4 Configuration:

- Probe: ES3DV2 - SN3017; ConvF(3.78, 3.78, 3.78); Calibrated: 2009-07-22
- Sensor-Surface: 4mm (Mechanical Surface Detection)
- Electronics: DAE4 Sn869; Calibrated: 2009-09-18
- Phantom: SAM 835/1900 MHz; Type: SAM

**WiMAX Body/Area Scan (41x61x1):** Measurement grid: dx=15mm, dy=15mm

[Info: Interpolated medium parameters used for SAR evaluation.](#)

Maximum value of SAR (interpolated) = 0.184 mW/g

**WiMAX Body/Zoom Scan (5x5x7)/Cube 0:** Measurement grid: dx=8mm, dy=8mm, dz=5mm

Reference Value = 4.27 V/m; Power Drift = -0.084 dB

Peak SAR (extrapolated) = 0.291 W/kg

**SAR(1 g) = 0.112 mW/g; SAR(10 g) = 0.043 mW/g**

[Info: Interpolated medium parameters used for SAR evaluation.](#)

Maximum value of SAR (measured) = 0.133 mW/g

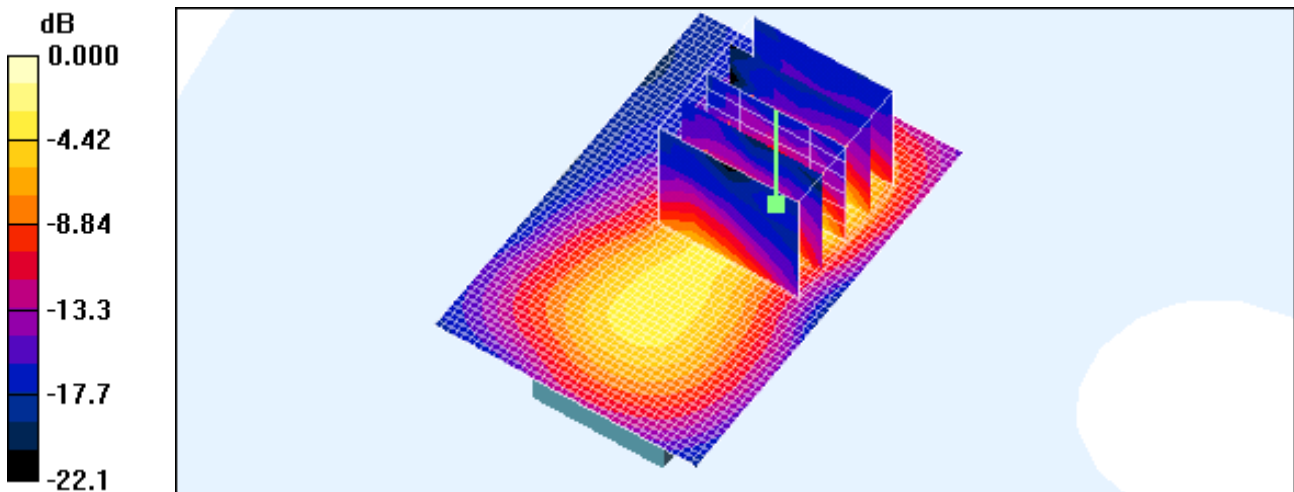

0 dB = 0.133mW/g

Test Laboratory: HCT CO., LTD  
EUT Type: USB Modem  
Liquid Temperature: 21.4 °C  
Ambient Temperature: 21.6 °C  
Test Date: Mar.26, 2010

**DUT: U600; Type: Bar; Serial: #1**

Communication System: WiMAX ; Frequency: 2593 MHz; Duty Cycle: 1:3.24  
Medium parameters used (interpolated):  $f = 2593$  MHz;  $\sigma = 2.17$  mho/m;  $\epsilon_r = 50.7$ ;  $\rho = 1000$  kg/m<sup>3</sup>  
Phantom section: Flat Section ; Measurement SW: DASY4, V4.7 Build 44; Postprocessing SW: SEMCAD, V1.8 Build 176

DASY4 Configuration:

- Probe: ES3DV2 - SN3017; ConvF(3.78, 3.78, 3.78); Calibrated: 2009-07-22
- Sensor-Surface: 4mm (Mechanical Surface Detection)
- Electronics: DAE4 Sn869; Calibrated: 2009-09-18
- Phantom: SAM 835/1900 MHz; Type: SAM

**WiMAX Body/Area Scan (41x61x1):** Measurement grid: dx=15mm, dy=15mm

[Info: Interpolated medium parameters used for SAR evaluation.](#)

Maximum value of SAR (interpolated) = 0.064 mW/g

**WiMAX Body/Zoom Scan (5x5x7)/Cube 0:** Measurement grid: dx=8mm, dy=8mm, dz=5mm

Reference Value = 1.90 V/m; Power Drift = 0.052 dB

Peak SAR (extrapolated) = 0.065 W/kg

**SAR(1 g) = 0.032 mW/g; SAR(10 g) = 0.013 mW/g**

[Info: Interpolated medium parameters used for SAR evaluation.](#)

Maximum value of SAR (measured) = 0.039 mW/g

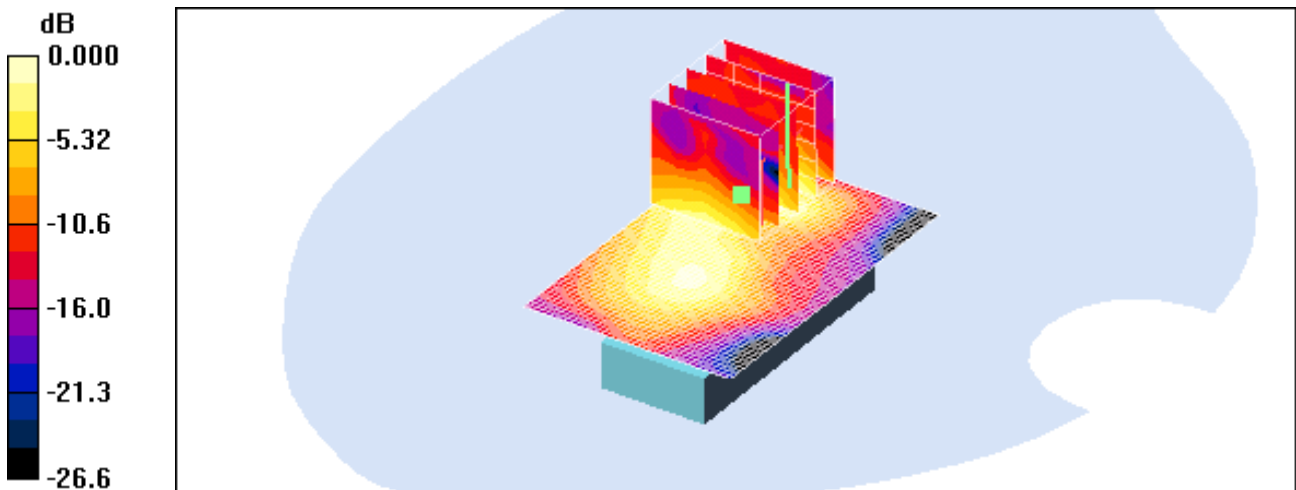

0 dB = 0.039mW/g

Test Laboratory: HCT CO., LTD  
EUT Type: USB Modem  
Liquid Temperature: 21.4 °C  
Ambient Temperature: 21.6 °C  
Test Date: Mar.26, 2010

**DUT: U600; Type: side; Serial: #1**

Communication System: WiMAX ; Frequency: 2593 MHz; Duty Cycle: 1:3.24  
Medium parameters used (interpolated):  $f = 2593$  MHz;  $\sigma = 2.17$  mho/m;  $\epsilon_r = 50.7$ ;  $\rho = 1000$  kg/m<sup>3</sup>  
Phantom section: Flat Section ; Measurement SW: DASY4, V4.7 Build 44; Postprocessing SW: SEMCAD, V1.8 Build 176

DASY4 Configuration:

- Probe: ES3DV2 - SN3017; ConvF(3.78, 3.78, 3.78); Calibrated: 2009-07-22
- Sensor-Surface: 4mm (Mechanical Surface Detection)
- Electronics: DAE4 Sn869; Calibrated: 2009-09-18
- Phantom: SAM 835/1900 MHz; Type: SAM

**Wimax Body 2593/Area Scan (41x71x1):** Measurement grid: dx=15mm, dy=15mm

[Info: Interpolated medium parameters used for SAR evaluation.](#)

Maximum value of SAR (interpolated) = 0.010 mW/g

**Wimax Body 2593/Zoom Scan (5x5x7)/Cube 0:** Measurement grid: dx=8mm, dy=8mm, dz=5mm

Reference Value = 0.743 V/m; Power Drift = 0.097 dB

Peak SAR (extrapolated) = 0.018 W/kg

**SAR(1 g) = 0.00853 mW/g; SAR(10 g) = 0.00385 mW/g**

Maximum value of SAR (measured) = 0.010 mW/g

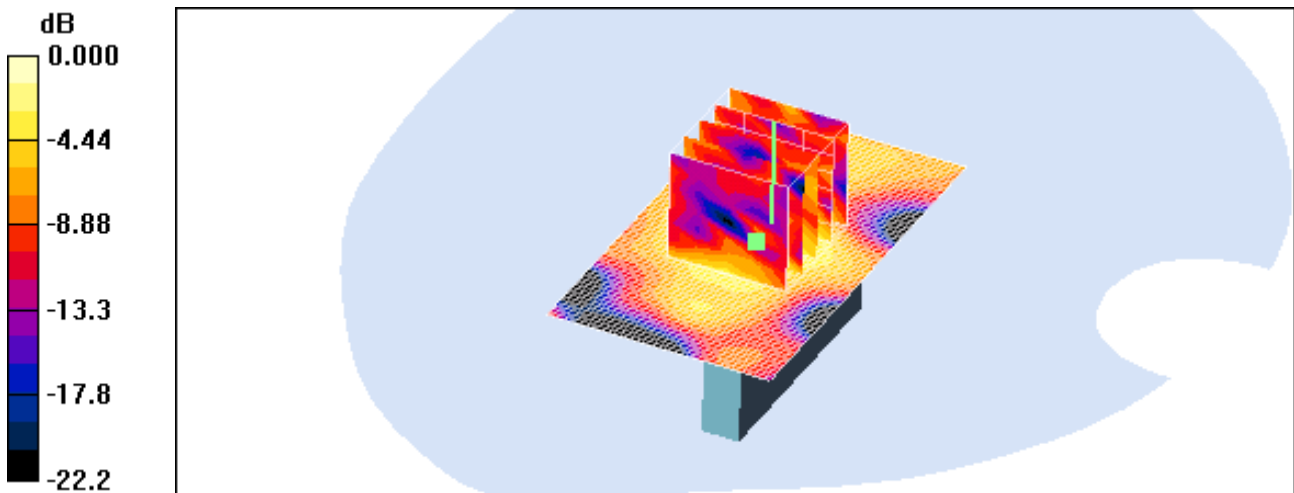

0 dB = 0.010mW/g

Test Laboratory: HCT CO., LTD  
EUT Type: USB Modem  
Liquid Temperature: 21.4 °C  
Ambient Temperature: 21.6 °C  
Test Date: Mar.26, 2010

**DUT: U600; Type: side; Serial: #1**

Communication System: WiMAX ; Frequency: 2593 MHz;Duty Cycle: 1:3.24  
Medium parameters used (interpolated):  $f = 2593$  MHz;  $\sigma = 2.17$  mho/m;  $\epsilon_r = 50.7$ ;  $\rho = 1000$  kg/m<sup>3</sup>  
Phantom section: Flat Section ; Measurement SW: DASY4, V4.7 Build 44; Postprocessing SW: SEMCAD, V1.8 Build 176

DASY4 Configuration:

- Probe: ES3DV2 - SN3017; ConvF(3.78, 3.78, 3.78); Calibrated: 2009-07-22
- Sensor-Surface: 4mm (Mechanical Surface Detection)
- Electronics: DAE4 Sn869; Calibrated: 2009-09-18
- Phantom: SAM 835/1900 MHz; Type: SAM

**Wimax Body 2593/Area Scan (41x71x1):** Measurement grid: dx=15mm, dy=15mm

[Info: Interpolated medium parameters used for SAR evaluation.](#)

Maximum value of SAR (interpolated) = 0.022 mW/g

**Wimax Body 2593/Zoom Scan (5x5x7)/Cube 0:** Measurement grid: dx=8mm, dy=8mm, dz=5mm

Reference Value = 2.12 V/m; Power Drift = 0.036 dB

Peak SAR (extrapolated) = 0.044 W/kg

**SAR(1 g) = 0.017 mW/g; SAR(10 g) = 0.00643 mW/g**

[Info: Interpolated medium parameters used for SAR evaluation.](#)

Maximum value of SAR (measured) = 0.022 mW/g

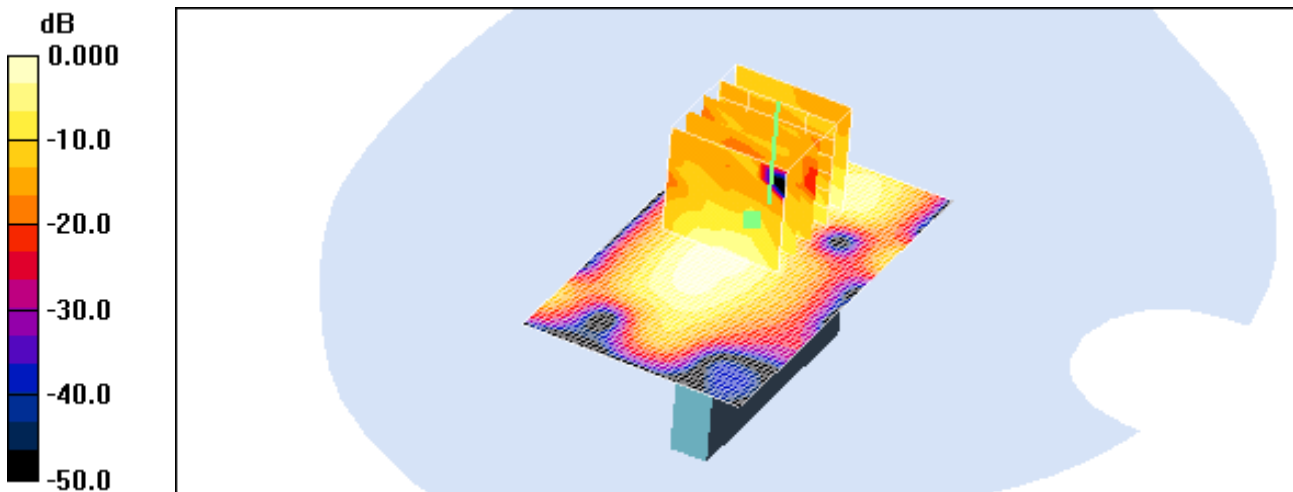

0 dB = 0.022mW/g



Test Laboratory: HCT CO., LTD  
EUT Type: USB Modem  
Liquid Temperature: 21.4 °C  
Ambient Temperature: 21.6 °C  
Test Date: Mar.26, 2010

**DUT: U600; Type: Bar; Serial: #1**

Communication System: WiMAX; Frequency: 2593 MHz; Duty Cycle: 1:3.24  
Medium parameters used (interpolated):  $f = 2593$  MHz;  $\sigma = 2.17$  mho/m;  $\epsilon_r = 50.7$ ;  $\rho = 1000$  kg/m<sup>3</sup>  
Phantom section: Flat Section ; Measurement SW: DASY4, V4.7 Build 44; Postprocessing SW: SEMCAD, V1.8 Build 176

DASY4 Configuration:

- Probe: ES3DV2 - SN3017; ConvF(3.78, 3.78, 3.78); Calibrated: 2009-07-22
- Sensor-Surface: 4mm (Mechanical Surface Detection)
- Electronics: DAE4 Sn869; Calibrated: 2009-09-18
- Phantom: SAM 835/1900 MHz; Type: SAM

**Wimax Body 2593/Area Scan (51x51x1):** Measurement grid: dx=15mm, dy=15mm

[Info: Interpolated medium parameters used for SAR evaluation.](#)

Maximum value of SAR (interpolated) = 0.022 mW/g

**Wimax Body 2593/Zoom Scan (5x5x7)/Cube 0:** Measurement grid: dx=8mm, dy=8mm, dz=5mm

Reference Value = 2.02 V/m; Power Drift = 0.086 dB

Peak SAR (extrapolated) = 0.029 W/kg

**SAR(1 g) = 0.017 mW/g; SAR(10 g) = 0.00683 mW/g**

[Info: Interpolated medium parameters used for SAR evaluation.](#)

Maximum value of SAR (measured) = 0.019 mW/g

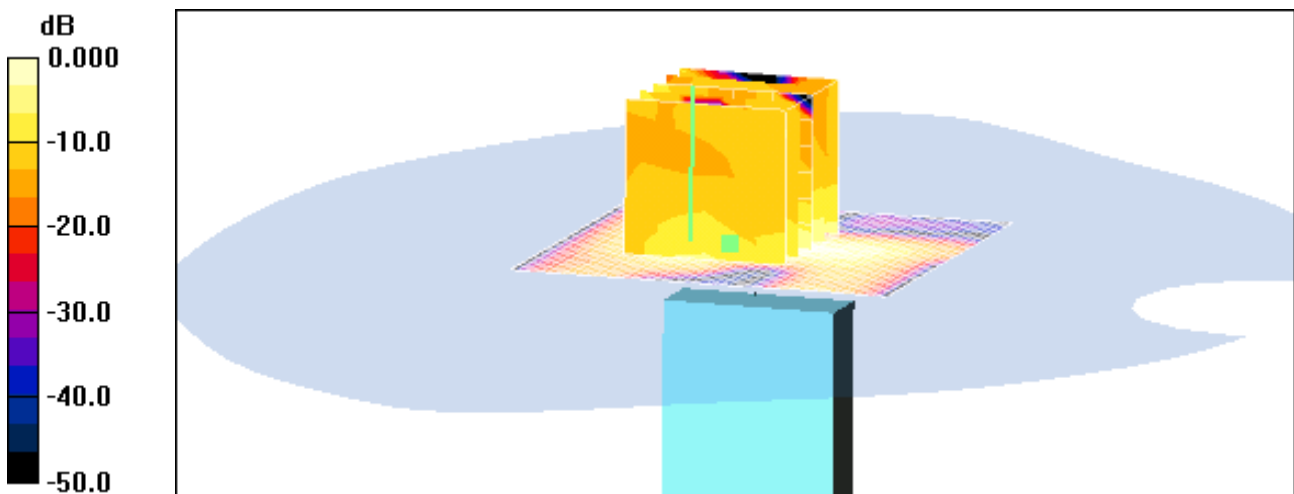

0 dB = 0.019mW/g

Test Laboratory: HCT CO., LTD  
EUT Type: USB Modem  
Liquid Temperature: 21.4 °C  
Ambient Temperature: 21.6 °C  
Test Date: Mar.26, 2010

**DUT: U600; Type: Bar; Serial: #1**

Communication System: WiMAX ; Frequency: 2593 MHz;Duty Cycle: 1:3.24  
Medium parameters used (interpolated):  $f = 2593$  MHz;  $\sigma = 2.17$  mho/m;  $\epsilon_r = 50.7$ ;  $\rho = 1000$  kg/m<sup>3</sup>  
Phantom section: Flat Section ; Measurement SW: DASY4, V4.7 Build 44; Postprocessing SW: SEMCAD, V1.8 Build 176

**DASY4 Configuration:**

- Probe: ES3DV2 - SN3017; ConvF(3.78, 3.78, 3.78); Calibrated: 2009-07-22
- Sensor-Surface: 4mm (Mechanical Surface Detection)
- Electronics: DAE4 Sn869; Calibrated: 2009-09-18
- Phantom: SAM 835/1900 MHz; Type: SAM

**WiMAX Body/Area Scan (41x61x1):** Measurement grid: dx=15mm, dy=15mm

[Info: Interpolated medium parameters used for SAR evaluation.](#)

Maximum value of SAR (interpolated) = 0.076 mW/g

**WiMAX Body/Zoom Scan (5x5x7)/Cube 0:** Measurement grid: dx=8mm, dy=8mm, dz=5mm

Reference Value = 3.59 V/m; Power Drift = 0.089 dB

Peak SAR (extrapolated) = 0.237 W/kg

**SAR(1 g) = 0.075 mW/g; SAR(10 g) = 0.027 mW/g**

[Info: Interpolated medium parameters used for SAR evaluation.](#)

Maximum value of SAR (measured) = 0.077 mW/g

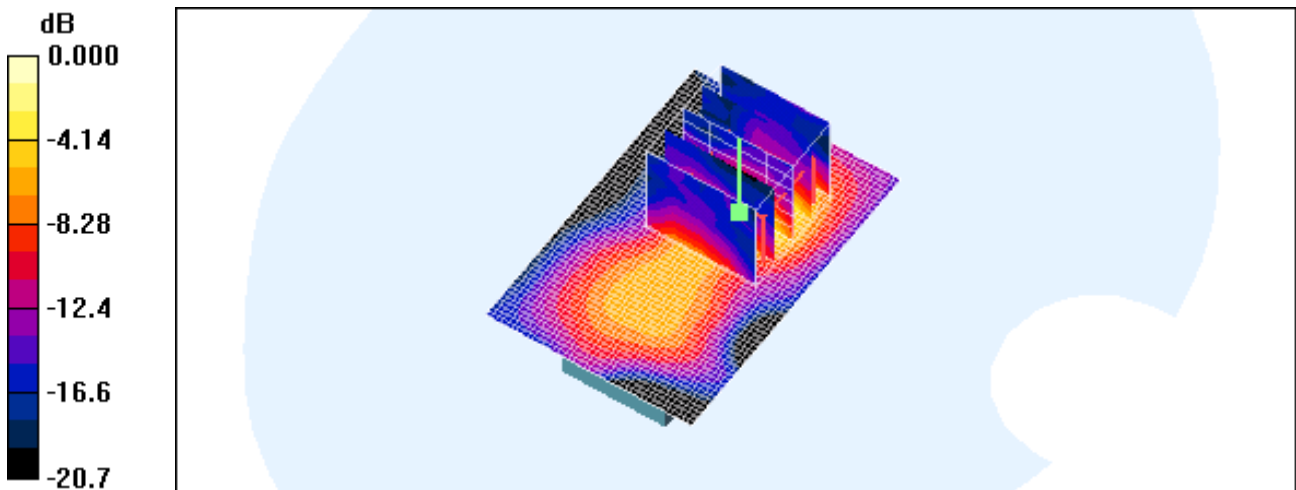

0 dB = 0.077mW/g

Test Laboratory: HCT CO., LTD  
EUT Type: USB Modem  
Liquid Temperature: 21.4 °C  
Ambient Temperature: 21.6 °C  
Test Date: Mar.26, 2010

**DUT: U600; Type: Bar; Serial: #1**

Communication System: WiMAX ; Frequency: 2593 MHz;Duty Cycle: 1:3.24  
Medium parameters used (interpolated):  $f = 2593$  MHz;  $\sigma = 2.17$  mho/m;  $\epsilon_r = 50.7$ ;  $\rho = 1000$  kg/m<sup>3</sup>  
Phantom section: Flat Section ; Measurement SW: DASY4, V4.7 Build 44; Postprocessing SW: SEMCAD, V1.8 Build 176

## DASY4 Configuration:

- Probe: ES3DV2 - SN3017; ConvF(3.78, 3.78, 3.78); Calibrated: 2009-07-22
- Sensor-Surface: 4mm (Mechanical Surface Detection)
- Electronics: DAE4 Sn869; Calibrated: 2009-09-18
- Phantom: SAM 835/1900 MHz; Type: SAM

**WiMAX Body/Area Scan (41x61x1):** Measurement grid: dx=15mm, dy=15mm

[Info: Interpolated medium parameters used for SAR evaluation.](#)

Maximum value of SAR (interpolated) = 0.074 mW/g

**WiMAX Body/Zoom Scan (5x5x7)/Cube 0:** Measurement grid: dx=8mm, dy=8mm, dz=5mm

Reference Value = 3.51 V/m; Power Drift = 0.080 dB

Peak SAR (extrapolated) = 0.176 W/kg

**SAR(1 g) = 0.068 mW/g; SAR(10 g) = 0.025 mW/g**

[Info: Interpolated medium parameters used for SAR evaluation.](#)

Maximum value of SAR (measured) = 0.075 mW/g

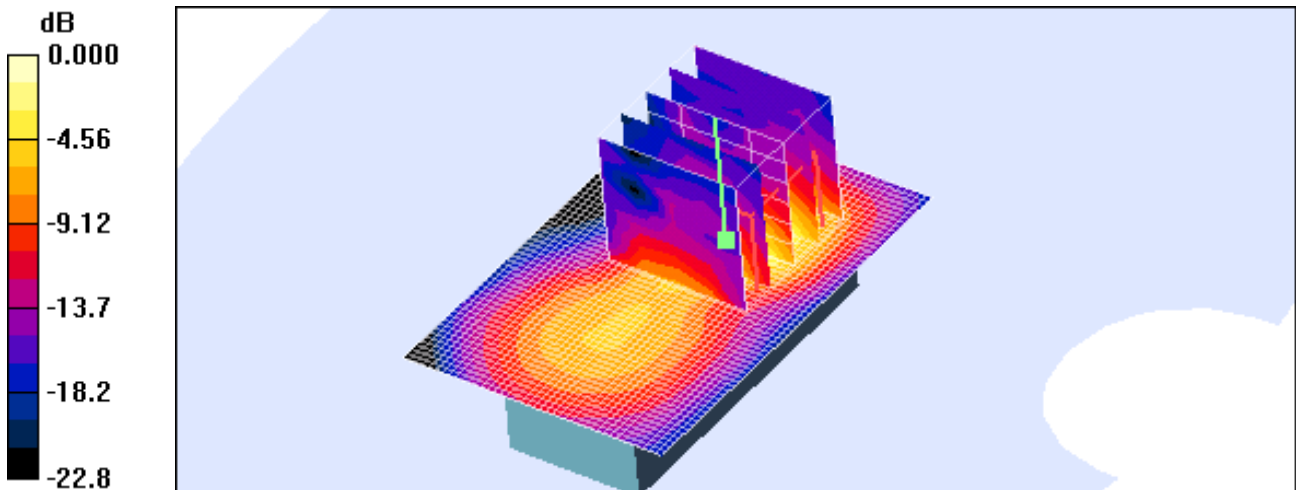

0 dB = 0.075mW/g

Test Laboratory: HCT CO., LTD  
EUT Type: USB Modem  
Liquid Temperature: 21.4 °C  
Ambient Temperature: 21.6 °C  
Test Date: Mar.26, 2010

**DUT: U600; Type: Bar; Serial: #1**

Communication System: WiMAX ; Frequency: 2593 MHz;Duty Cycle: 1:3.24  
Medium parameters used (interpolated):  $f = 2593$  MHz;  $\sigma = 2.17$  mho/m;  $\epsilon_r = 50.7$ ;  $\rho = 1000$  kg/m<sup>3</sup>  
Phantom section: Flat Section ; Measurement SW: DASY4, V4.7 Build 44; Postprocessing SW: SEMCAD, V1.8 Build 176

DASY4 Configuration:

- Probe: ES3DV2 - SN3017; ConvF(3.78, 3.78, 3.78); Calibrated: 2009-07-22
- Sensor-Surface: 4mm (Mechanical Surface Detection)
- Electronics: DAE4 Sn869; Calibrated: 2009-09-18
- Phantom: SAM 835/1900 MHz; Type: SAM

**WIMAX Body/Area Scan (41x61x1):** Measurement grid: dx=15mm, dy=15mm

[Info: Interpolated medium parameters used for SAR evaluation.](#)

Maximum value of SAR (interpolated) = 0.078 mW/g

**WIMAX Body/Zoom Scan (5x5x7)/Cube 0:** Measurement grid: dx=8mm, dy=8mm, dz=5mm

Reference Value = 3.67 V/m; Power Drift = 0.073 dB

Peak SAR (extrapolated) = 0.178 W/kg

**SAR(1 g) = 0.070 mW/g; SAR(10 g) = 0.026 mW/g**

[Info: Interpolated medium parameters used for SAR evaluation.](#)

Maximum value of SAR (measured) = 0.078 mW/g

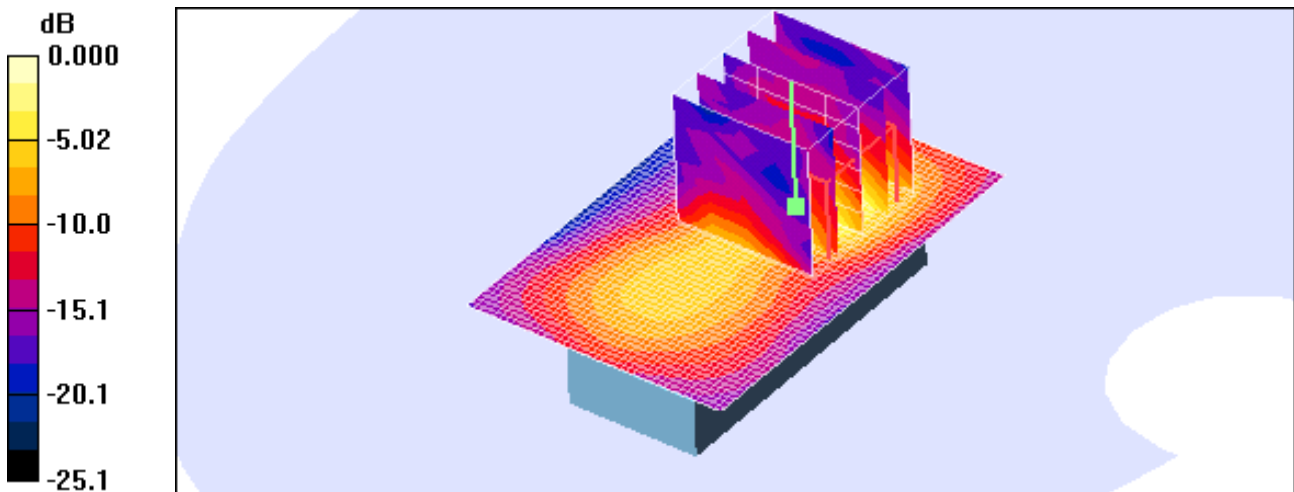

0 dB = 0.078mW/g

Test Laboratory: HCT CO., LTD  
EUT Type: USB Modem  
Liquid Temperature: 21.4 °C  
Ambient Temperature: 21.6 °C  
Test Date: Mar.26, 2010

**DUT: U600; Type: Bar; Serial: #1**

Communication System: WiMAX ; Frequency: 2593 MHz; Duty Cycle: 1:3.24  
Medium parameters used (interpolated):  $f = 2593$  MHz;  $\sigma = 2.17$  mho/m;  $\epsilon_r = 50.7$ ;  $\rho = 1000$  kg/m<sup>3</sup>  
Phantom section: Flat Section ; Measurement SW: DASY4, V4.7 Build 44; Postprocessing SW: SEMCAD, V1.8 Build 176

DASY4 Configuration:

- Probe: ES3DV2 - SN3017; ConvF(3.78, 3.78, 3.78); Calibrated: 2009-07-22
- Sensor-Surface: 4mm (Mechanical Surface Detection)
- Electronics: DAE4 Sn869; Calibrated: 2009-09-18
- Phantom: SAM 835/1900 MHz; Type: SAM

**WiMAX Body/Area Scan (41x61x1):** Measurement grid: dx=15mm, dy=15mm

[Info: Interpolated medium parameters used for SAR evaluation.](#)

Maximum value of SAR (interpolated) = 0.089 mW/g

**WiMAX Body/Zoom Scan (5x5x7)/Cube 0:** Measurement grid: dx=8mm, dy=8mm, dz=5mm

Reference Value = 3.65 V/m; Power Drift = 0.040 dB

Peak SAR (extrapolated) = 0.192 W/kg

**SAR(1 g) = 0.071 mW/g; SAR(10 g) = 0.027 mW/g**

[Info: Interpolated medium parameters used for SAR evaluation.](#)

Maximum value of SAR (measured) = 0.078 mW/g

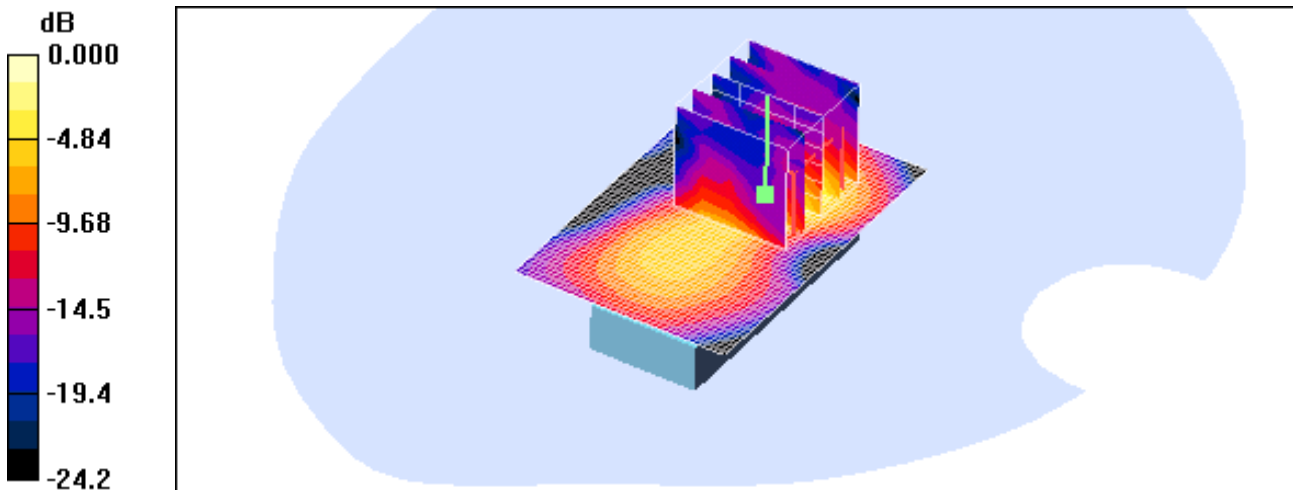

0 dB = 0.078mW/g

Test Laboratory: HCT CO., LTD  
EUT Type: USB Modem  
Liquid Temperature: 21.4 °C  
Ambient Temperature: 21.6 °C  
Test Date: Mar.26, 2010

**DUT: U600; Type: Bar; Serial: #1**

Communication System: WiMAX ; Frequency: 2593 MHz; Duty Cycle: 1:3.24  
Medium parameters used (interpolated):  $f = 2593$  MHz;  $\sigma = 2.17$  mho/m;  $\epsilon_r = 50.7$ ;  $\rho = 1000$  kg/m<sup>3</sup>  
Phantom section: Flat Section ; Measurement SW: DASY4, V4.7 Build 71; Postprocessing SW: SEMCAD, V1.8 Build 176

## DASY4 Configuration:

- Probe: ES3DV2 - SN3017; ConvF(3.78, 3.78, 3.78); Calibrated: 2009-07-22
- Sensor-Surface: 4mm (Mechanical Surface Detection)
- Electronics: DAE4 Sn869; Calibrated: 2009-09-18
- Phantom: SAM 1800/1900 MHz; Type: SAM

**WiMAX Body 2593/Area Scan (41x61x1):** Measurement grid: dx=15mm, dy=15mm

[Info: Interpolated medium parameters used for SAR evaluation.](#)

Maximum value of SAR (interpolated) = 0.733 mW/g

**WiMAX Body 2593/Zoom Scan (5x5x7)/Cube 0:** Measurement grid: dx=8mm, dy=8mm, dz=5mm

Reference Value = 14.3 V/m; Power Drift = -0.114 dB

Peak SAR (extrapolated) = 1.62 W/kg

**SAR(1 g) = 0.675 mW/g; SAR(10 g) = 0.286 mW/g**

[Info: Interpolated medium parameters used for SAR evaluation.](#)

Maximum value of SAR (measured) = 0.742 mW/g

