

EMI TEST REPORT FCC CERTIFICATION

Applicant:

Franklin Technology Inc.

906 JEI Platz, 186, Gasan digital 1-ro, Geumcheon-gu,
Seoul, 08502 South Korea

Date of Issue: February 08, 2019

Test Report No. HCT-EM-1901-FC012-R1

Test Site: HCT CO., LTD.

MODEL:

T720

Rule Part(s) / Standard(s) : FCC CFR 47 PART 15 Subpart B Class B
ANSI C63.4-2014

FCC ID : XHG-T720

EUT Type : VoLTE+CDMA Home Phone Connect

Manufacturer : Franklin Technology Inc.

Date of Test : January 18, 2019 to January 27, 2019

The device bearing the trade name and model specified above, has been shown to comply with the applicable technical standards as indicated in the measurement report and was tested in accordance with the measurement procedures specified in ANSI C63.4-2014. (See Test Report if any modifications were made for compliance)

I attest to the accuracy of data. All measurements reported herein were performed by me or were made under my supervision and are correct to the best of my knowledge and belief. I assume full responsibility for the completeness of these measurements and vouch for the qualifications of all persons taking them. HCT certifies that no party to application has been denied the FCC benefits pursuant to Section 5301 of the Anti-Drug Abuse Act of 1988, 21 U.S.C 862

Tested By



Kyoung-Hee Yoon
Test Engineer
EMC Team
Certification Division

Reviewed By



Jin-Pyo Hong
Technical Manager
EMC Team
Certification Division

This report only responds to the tested sample and may not be reproduced, except in full, without written approval of the HCT Co., Ltd.



REVISION HISTORY

The revision history for this document is shown in table.

Test Report No.	Issue Date	Description
HCT-EM-1901-FC012	January 30, 2019	Initial Release
HCT-EM-1901-FC012-R1	February 08, 2019	Added note (Clause 4.2, NOTE 2)



TABLE OF CONTENTS

	PAGE
1. GENERAL INFORMATION.....	4
1.1 Description of EUT	4
1.2 Tested System Details.....	4
1.3 Cable Description	4
1.4 Noise Suppression Parts on Cable. (I/O Cable).....	5
1.5 Test Facility	5
1.6 Instrument Calibration.....	5
1.7. Measurement Uncertainty.....	5
2 LIST OF TEST EQUIPMENT	6
3. DESCRIPTION OF TEST	7
3.1 Measurement of Conducted Emission	7
3.2 Measurement of Radiated Emission	8
4. PRELIMINARY TEST	10
4.1 Conducted Emission	10
4.2 Radiated Emission	10
5. CONDUCTED AND RADIATED EMISSION TEST SUMMARY	11
5.1 Conducted Emission	11
5.2 Radiated Emission	48
6. CONCLUSION	60
7. APPENDIX A. TEST SETUP PHOTOGRAPHS	61



1. GENERAL INFORMATION

1.1 Description of EUT

The EUT is VoLTE+CDMA Home Phone Connect

FCC ID	XHG-T720	
Model	T720	
EUT type	VoLTE+CDMA Home Phone Connect	
TX Frequency	CDMA BC0: 824 MHz to 849 MHz CDMA BC1: 1 850 MHz to 1 910 MHz LTE B5: 824 MHz to 849 MHz LTE B12: 699 MHz to 716 MHz LTE B25: 1 850 MHz to 1 915 MHz LTE B41: 2 496 MHz to 2 690 MHz	
Power voltage	Switching adapter	AC Input voltage: Minimum: 90 VAC, Nominal: 100 to 240 VAC Maximum: 264 VA DC Output voltage: +5 V
	Battery	Rated capacity: 2 100 mAh, Rated voltage: 3.8 V
Manufacturer	Franklin Technology Inc.	

1.2 Tested System Details

All equipment descriptions used in the tested system (including inserted cards) are:

Equipment	Model No.	Serial Number	Manufacturer
EUT	T720	-	Franklin Technology
Switching adapter	CYSE12-050200U	-	JIANGSU CHENYANG ELECTRON
Telephone	SP-F470	S2TB200938J	SAMSUNG

1.3 Cable Description

Product Name	Port	Power Cord Shielded (Y/N)	I/O Cable Shielded (Y/N)	Length (m)
EUT	MICRO USB	N	N/A	1.2
	RJ 11	N/A	N	2.2
	RJ 11	N/A	N	2.2



1.4 Noise Suppression Parts on Cable. (I/O Cable)

Product Name	Port	Ferrite Bead (Y/N)	Location	Metal Hood (Y/N)	Location
EUT	MICRO USB	N/A	N/A	Y	Both End
	RJ 11	N/A	N/A	Y	Both End
	RJ 11	N/A	N/A	Y	Both End

1.5 Test Facility

Test site is located at 74, SEOICHEON-RO, 578BEON-GIL, MAJANG-MYEON, ICHEON-SI, GYEONGGI-DO, SOUTH KOREA. Those measurement facilities are constructed in conformance with the requirements of ANSI C63.4-2014. The Normalized site attenuations (30 MHz to 1 GHz) and site validation (1 GHz to 18 GHz) were performed in accordance with the standard in ANSI C63.4-2014

Measurement Facilities	Registration Number
Radiated Field strength measurement facility 3 m Semi Anechoic chamber	90661
Radiated Field strength measurement facility 10 m Semi Anechoic chamber	

1.6 Instrument Calibration

The measuring equipment, which was utilized in performing the tests documented herein, has been calibrated in accordance with the manufacturers recommendations for utilizing calibration equipment's, which is traceable to recognized national standards.

Especially, all antenna for measurement is calibrated in accordance with the requirements of C63.5 (Version : 2006).

1.7. Measurement Uncertainty

The measurement uncertainties shown below were calculated in accordance with the requirements of ANSI C63.4-2014. All measurement uncertainty values are shown with a coverage factor of $k = 2$ to indicate a 95 % level of confidence. The measurement data shown herein meets or exceeds the U_{CISPR} measurement uncertainty values specified in CISPR 16-4-2 and, thus, can be compared directly to specified limits to determine compliance.

Parameter	Expanded Uncertainty (dB)
Conducted Emission (0.15 MHz to 30 MHz)	1.82 dB
3 m Radiated Emissions (30 MHz to 1 GHz)	5.20 dB
3 m Radiated Emissions (1 GHz to 18 GHz)	5.24 dB
3 m Radiated Emissions (18 GHz to 40 GHz)	5.40 dB



2 LIST OF TEST EQUIPMENT

Type	Manufacturer	Model Name	Serial Number	Calibration Cycle	CAL Date
<u>Conducted Emission</u>					
<input checked="" type="checkbox"/> EMI Test Receiver	Rohde & Schwarz	ESCI	100584	1 year	06.25.2018
<input type="checkbox"/> EMI Test Receiver	Rohde & Schwarz	ESCI	100033	1 year	06.27.2018
<input checked="" type="checkbox"/> LISN	Rohde & Schwarz	ENV216	102245	1 year	12.12.2018
<input checked="" type="checkbox"/> LISN	Rohde & Schwarz	ENV216	100073	1 year	05.03.2018
<input checked="" type="checkbox"/> Software	Rohde & Schwarz	EMC32 VER8.54.0	-	-	-
<u>Radiated Emission</u>					
-For measurement below 1 GHz					
<input checked="" type="checkbox"/> EMI Test Receiver	Rohde & Schwarz	ESU40	100524	1 year	07.27.2018
<input checked="" type="checkbox"/> Trilog Antenna	Schwarzbeck	VULB 9168	847	2 year	04.13.2018
<input checked="" type="checkbox"/> Antenna Master	INNCO Systems	MA4640-XP-ET	-	N/A	-
<input checked="" type="checkbox"/> Antenna master controller	INNCO Systems	CO 3000	CO3000/870/ 35990515/L	N/A	-
<input checked="" type="checkbox"/> Turn Table	INNCO Systems	1060-2M	-	N/A	-
<input checked="" type="checkbox"/> Turn Table controller	INNCO Systems	CO2000	CO2000/095/ 5790304/L	N/A	-
<input type="checkbox"/> Low Noise Amplifier	TESTEK	TK-PA01S	160014-L	1 year	01.21.2019
<input type="checkbox"/> EMI Test Receiver	Rohde & Schwarz	ESU26	100241	1 year	08.14.2018
<input type="checkbox"/> Antenna master	INNCO Systems	MA4000-EP	MA4000/283	N/A	-
<input type="checkbox"/> Turn Table	INNCO Systems	DT3000-3T	DT3000/69	N/A	-
<input checked="" type="checkbox"/> Software	Rohde & Schwarz	EMC32 VER.9.20.00	-	-	-
-For measurement above 1 GHz					
<input checked="" type="checkbox"/> EMI Test Receiver	Rohde & Schwarz	ESU40	100524	1 year	07.27.2018
<input checked="" type="checkbox"/> Antenna master	INNCO Systems	MA4640-XP-ET	-	N/A	-
<input checked="" type="checkbox"/> Antenna master controller	INNCO Systems	CO 3000	CO 3000/870/ 35990515/L	N/A	-
<input checked="" type="checkbox"/> Turn Table	INNCO Systems	1060-2M	-	N/A	-
<input checked="" type="checkbox"/> Turn Table controller	INNCO Systems	CO2000	CO2000/095/ 5790304/L	N/A	-
<input checked="" type="checkbox"/> Horn Antenna	Schwarzbeck	BBHA 9120D	01836	2 year	05.14.2018
<input checked="" type="checkbox"/> Low Noise Amplifier	TESTEK	TK-PA18H	170034-L	1 year	03.06.2018
<input type="checkbox"/> Power Amplifier	TESTEK	TK-PA1840H	170030-L	1 year	12.17.2018
<input type="checkbox"/> Antenna master	HD GmbH	MA240	240/520	N/A	-
<input type="checkbox"/> EMI Test Receiver	Rohde & Schwarz	ESU26	100241	1 year	08.14.2018
<input type="checkbox"/> Turn Table	INNCO Systems	DT3000-3T	DT3000/69	N/A	-
<input checked="" type="checkbox"/> Software	Rohde & Schwarz	EMC32 VER8.40.0	-	-	-



3. DESCRIPTION OF TEST

3.1 Measurement of Conducted Emission

The test procedure was in accordance with ANSI C63.4-2014

- a. The EUT was placed 0.4 meters from the conducting wall of the shielded room with EUT being connected to the power mains through a line impedance stabilization network (LISN).
If the EUT is connected to the PC through USB, the AC power-line adapter of the PC is directly connected to a line impedance stabilization network (LISN).
Other support units were connected to the power mains through another LISN. The two LISNs provide 50 Ohm/ 50uH of coupling impedance for the measuring instrument.
- b. Both conducted lines are measured in Quasi-Peak and Average mode, including the worst-case data points for each tested configuration.
- c. The frequency range from 150 kHz to 30 MHz was searched.

[Conducted Emission Limit]

Frequency (MHz)	Resolution Bandwidth (kHz)	Class A		Class B	
		Quasi-Peak (dBμV)	Average (dBμV)	Quasi-Peak (dBμV)	Average (dBμV)
0.15 to 0.5	9	79	66	66 to 56*	56 to 46*
0.5 to 5	9	73	60	56	46
5 to 30	9	73	60	60	50

**Decreases with the logarithm of the frequency.*



3.2 Measurement of Radiated Emission

The test procedure was in accordance with ANSI C63.4-2014

- a. The EUT was placed on the top of a turn table 0.8 meters above the ground at a semi anechoic chamber. The table was rotated 360 degrees to determine the position of the highest radiation.
- b. The EUT was set 3 m away from the interference-receiving antenna, which was mounted on the top of a variable-height antenna tower.
- c. The antenna height is varied from 1 m to 4 m above the ground to determine the maximum value of the field strength. Both horizontal and vertical polarizations of the antenna are set to make the measurement.
- d. For each suspected emission, the EUT was arranged to its worst case and then the antenna was tuned to heights from 1 m to 4 m and the turn table was turned from 0 degrees to 360 degrees to find the maximum reading.
- e. The test-receiver system was set to Quasi-Peak detect function and specified bandwidth with maximum hold mode when the test frequency is below 1 GHz.
- f. The test-receiver system was set to Peak and Average detect function and specified bandwidth with maximum hold mode when the test frequency is above 1 GHz.
- g. Place the measurement antenna away from each area of the EUT determined to be a source of emissions at the specified measurement distance, while keeping the measurement antenna aimed at the source of emissions at each frequency of significant emissions, with polarization oriented for maximum response.(1 GHz to 40 GHz)

[Radiated Emission Limits]

Frequency (MHz)	Class A			Class B		
	Antenna Distance (m)	Field Strength (μV/m)	Quasi-Peak (dBμV/m)	Antenna Distance (m)	Field Strength (μV/m)	Quasi-Peak (dBμV/m)
30 to 88	10	90	39.0	3	100	40.0
88 to 216	10	150	43.5	3	150	43.5
216 to 960	10	210	46.4	3	200	46.0
Above 960	10	300	49.5	3	500	54.0
Frequency (MHz)	Antenna Distance (m)	Class A		Class B		
		Peak (dBμV/m)	Average (dBμV/m)	Peak (dBμV/m)	Average (dBμV/m)	
Above 1 000	3	80	60	74	54	



3.2.1 Frequency Range of Radiated Measurements

An unintentional radiator, including a digital device, the spectrum shall be investigated from the lowest radio frequency signal generated or used in the device, without going below the lowest frequency for which a Radiated Emission limit is specified, up to the frequency shown in the following table

Highest frequency generated or used in the device or on which the device operates or tunes (MHz)	Upper frequency of measurement range (MHz)
Below 1.705	30
1.705 to 108	1 000
108 to 500	2 000
500 to 1 000	5 000
Above 1 000	5 th harmonic of the highest frequency or 40 GHz, whichever is lower

3.3 Configuration of Tested System

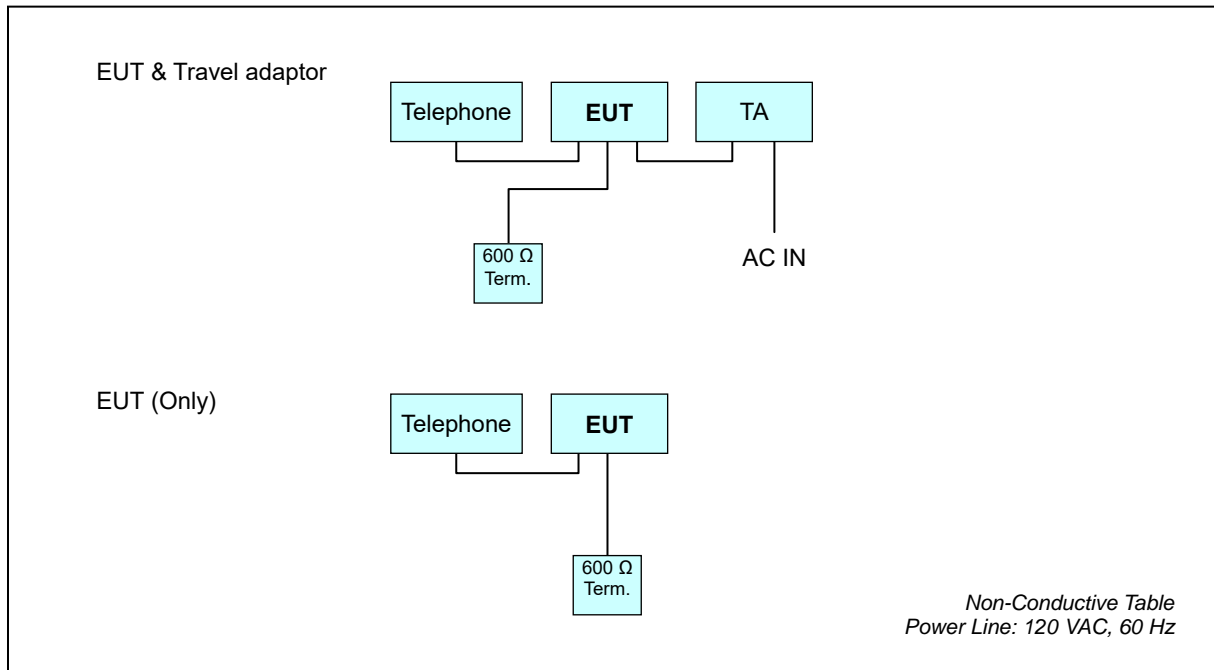



4. PRELIMINARY TEST

4.1 Conducted Emission

During preliminary tests, the following operating mode was investigated:

Operation Mode:

Charging + CDMA BC0 RX Receiving mode
Charging + CDMA BC1 RX Receiving mode
Charging + LTE BAND 5 RX Receiving mode
Charging + LTE BAND 12 RX Receiving mode
Charging + LTE BAND 25 RX Receiving mode
Charging + LTE BAND 41 RX Receiving mode

4.2 Radiated Emission

During preliminary tests, the following operating mode was investigated:

Operation Mode:

Charging + CDMA BC0 RX Receiving mode
Charging + CDMA BC1 RX Receiving mode
Charging + LTE BAND 5 RX Receiving mode
Charging + LTE BAND 12 RX Receiving mode
Charging + LTE BAND 25 RX Receiving mode
Charging + LTE BAND 41 RX Receiving mode
CDMA BC0 RX Receiving mode
CDMA BC1 RX Receiving mode
LTE BAND 5 RX Receiving mode
LTE BAND 12 RX Receiving mode
LTE BAND 25 RX Receiving mode
LTE BAND 41 RX Receiving mode

NOTE.

1. The EUT is powered by an internal battery or a switching adapter and has only ports to connect the phone and can't be wired to the PC (IT equipment)
2. All modes of operation were verified and the worst case configuration result was indicated in the test report.



5. CONDUCTED AND RADIATED EMISSION TEST SUMMARY

5.1 Conducted Emission

The test results of conducted emission at mains ports provide the following information:

Rule Part / Standard	FCC PART 15 Subpart B Class B
Detector	Quasi-Peak, CISPR-Average
Bandwidth	9 kHz (6 dB)
Kind of Test Site	EMI Shielded Room
Temperature	23.1
Relative Humidity	42.6
Test Date	January 18, 2019

- Calculation Formula:

1. Conductor L1 = Hot, Conductor N = Neutral
2. Corr. = LISN Factor + Cable Loss
3. QuasiPeak or CAverage= Receiver Reading + Corr.
4. Margin = Limit – QuasiPeak or CAverage



Figure 1: Conducted Emission, Charging + CDMA BC0 RX Receiving mode, Line (L1)

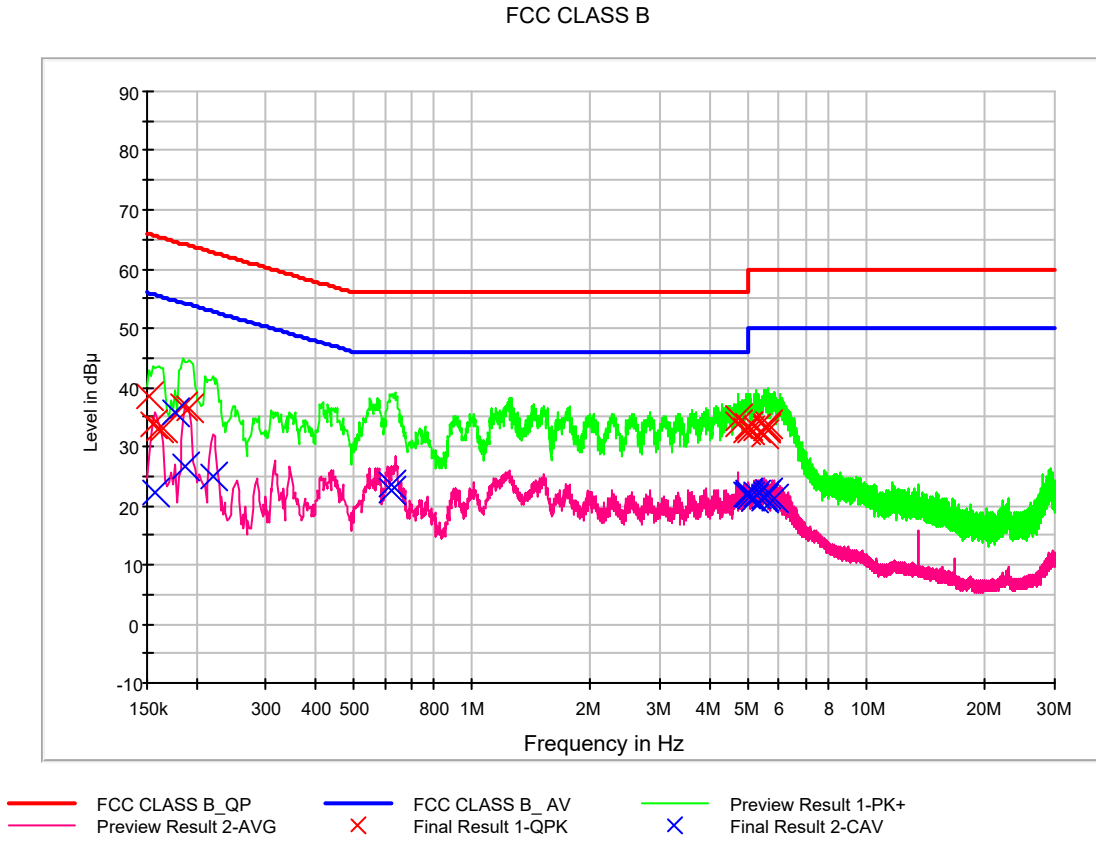



QuasiPeak Final Result, Line (L1)

Frequency (MHz)	QuasiPeak (dBuV)	Bandwidth (kHz)	Line	Corr. (dB)	Margin (dB)	Limit (dBuV)
0.152000	38.4	9.000	L1	9.6	27.5	65.9
0.156000	33.8	9.000	L1	9.6	31.8	65.7
0.160000	33.0	9.000	L1	9.6	32.5	65.5
0.164000	33.2	9.000	L1	9.6	32.1	65.3
0.186000	36.8	9.000	L1	9.7	27.4	64.2
0.192000	36.4	9.000	L1	9.7	27.6	63.9
4.714000	33.7	9.000	L1	9.8	22.3	56.0
4.718000	34.6	9.000	L1	9.8	21.4	56.0
4.954000	32.6	9.000	L1	9.8	23.4	56.0
4.994000	33.2	9.000	L1	9.8	22.8	56.0
5.016000	33.3	9.000	L1	9.8	26.7	60.0
5.090000	32.8	9.000	L1	9.8	27.2	60.0
5.262000	33.2	9.000	L1	9.9	26.8	60.0
5.482000	32.2	9.000	L1	9.9	27.8	60.0
5.562000	33.1	9.000	L1	9.9	26.9	60.0
5.570000	33.2	9.000	L1	9.9	26.8	60.0
5.588000	33.5	9.000	L1	9.9	26.5	60.0
5.626000	33.7	9.000	L1	9.9	26.3	60.0



CAverage Final Result, Line (L1)

Frequency (MHz)	CAverage (dBuV)	Bandwidth (kHz)	Line	Corr. (dB)	Margin (dB)	Limit (dBuV)
0.158000	22.4	9.000	L1	9.6	33.2	55.6
0.176000	35.8	9.000	L1	9.6	18.9	54.7
0.188000	26.5	9.000	L1	9.7	27.7	54.1
0.220000	25.1	9.000	L1	9.7	27.7	52.8
0.624000	23.4	9.000	L1	9.7	22.6	46.0
0.628000	22.7	9.000	L1	9.7	23.3	46.0
4.960000	21.9	9.000	L1	9.8	24.1	46.0
4.994000	21.9	9.000	L1	9.8	24.1	46.0
5.010000	22.1	9.000	L1	9.8	27.9	50.0
5.018000	21.9	9.000	L1	9.8	28.1	50.0
5.090000	21.4	9.000	L1	9.8	28.6	50.0
5.204000	21.1	9.000	L1	9.8	28.9	50.0
5.262000	22.0	9.000	L1	9.9	28.0	50.0
5.506000	21.1	9.000	L1	9.9	28.9	50.0
5.532000	21.5	9.000	L1	9.9	28.5	50.0
5.570000	21.8	9.000	L1	9.9	28.2	50.0
5.616000	22.2	9.000	L1	9.9	27.8	50.0
5.868000	21.2	9.000	L1	9.9	28.8	50.0



Figure 2: Conducted Emission, Charging + CDMA BC0 RX Receiving mode, Line (N)

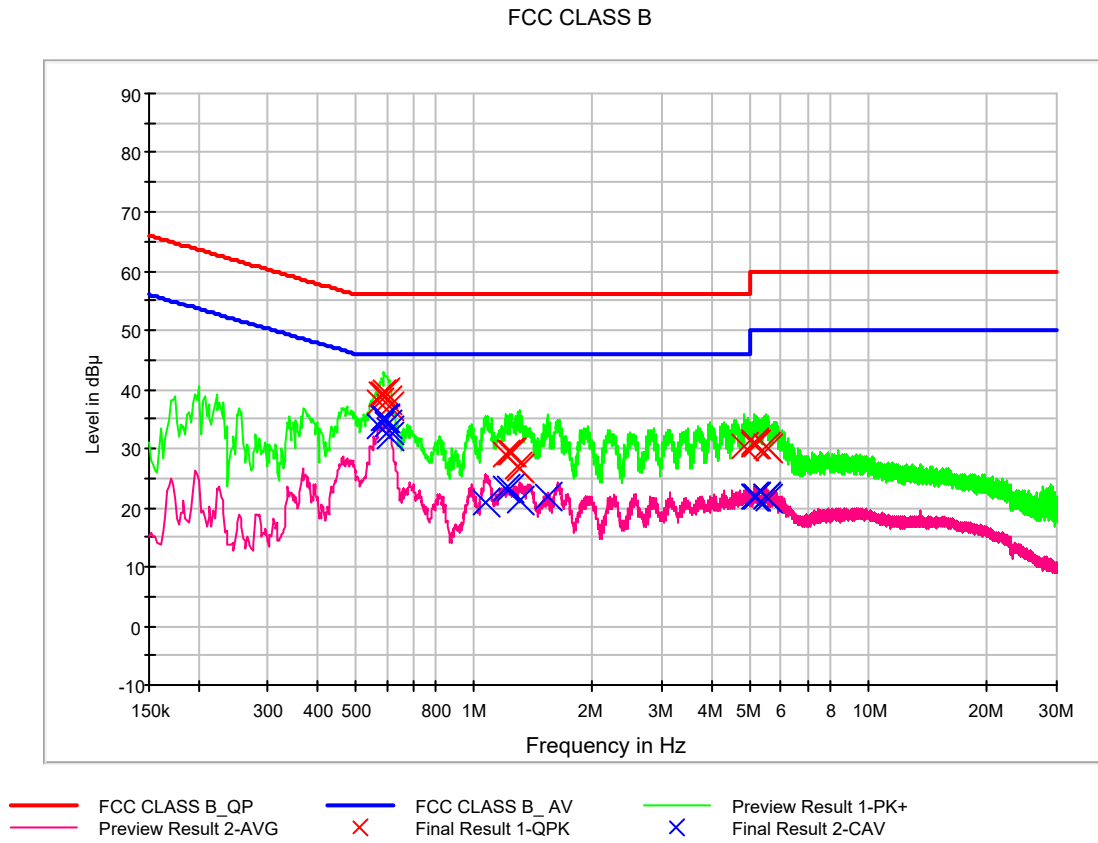



QuasiPeak Final Result, Line (N)

Frequency (MHz)	QuasiPeak (dBuV)	Bandwidth (kHz)	Line	Corr. (dB)	Margin (dB)	Limit (dBuV)
0.578000	38.0	9.000	N	9.7	18.0	56.0
0.584000	39.2	9.000	N	9.7	16.8	56.0
0.590000	39.0	9.000	N	9.7	17.0	56.0
0.596000	39.5	9.000	N	9.7	16.5	56.0
0.606000	38.3	9.000	N	9.7	17.7	56.0
0.612000	37.1	9.000	N	9.7	18.9	56.0
1.200000	28.8	9.000	N	9.7	27.2	56.0
1.228000	29.3	9.000	N	9.7	26.7	56.0
1.242000	29.4	9.000	N	9.7	26.6	56.0
1.292000	26.8	9.000	N	9.7	29.2	56.0
1.306000	26.7	9.000	N	9.7	29.3	56.0
4.854000	30.4	9.000	N	9.8	25.6	56.0
5.148000	30.6	9.000	N	9.8	29.4	60.0
5.156000	30.9	9.000	N	9.8	29.1	60.0
5.160000	30.7	9.000	N	9.8	29.3	60.0
5.172000	30.7	9.000	N	9.8	29.3	60.0
5.492000	30.5	9.000	N	9.8	29.5	60.0
5.550000	29.9	9.000	N	9.9	30.1	60.0



CAverage Final Result, Line (N)

Frequency (MHz)	CAverage (dBuV)	Bandwidth (kHz)	Line	Corr. (dB)	Margin (dB)	Limit (dBuV)
0.578000	33.6	9.000	N	9.7	12.4	46.0
0.590000	35.1	9.000	N	9.7	10.9	46.0
0.596000	35.0	9.000	N	9.7	11.0	46.0
0.600000	34.2	9.000	N	9.7	11.8	46.0
0.608000	32.9	9.000	N	9.7	13.1	46.0
0.612000	31.9	9.000	N	9.7	14.1	46.0
1.074000	21.0	9.000	N	9.7	25.0	46.0
1.200000	23.2	9.000	N	9.7	22.8	46.0
1.228000	23.3	9.000	N	9.7	22.7	46.0
1.306000	21.1	9.000	N	9.7	24.9	46.0
1.530000	22.0	9.000	N	9.7	24.0	46.0
5.126000	21.8	9.000	N	9.8	28.2	50.0
5.160000	22.0	9.000	N	9.8	28.0	50.0
5.172000	22.0	9.000	N	9.8	28.0	50.0
5.198000	22.0	9.000	N	9.8	28.0	50.0
5.488000	21.7	9.000	N	9.8	28.3	50.0
5.492000	21.7	9.000	N	9.8	28.3	50.0
5.550000	21.6	9.000	N	9.9	28.4	50.0



Figure 3: Conducted Emission, Charging + CDMA BC1 RX Receiving mode, Line (L1)

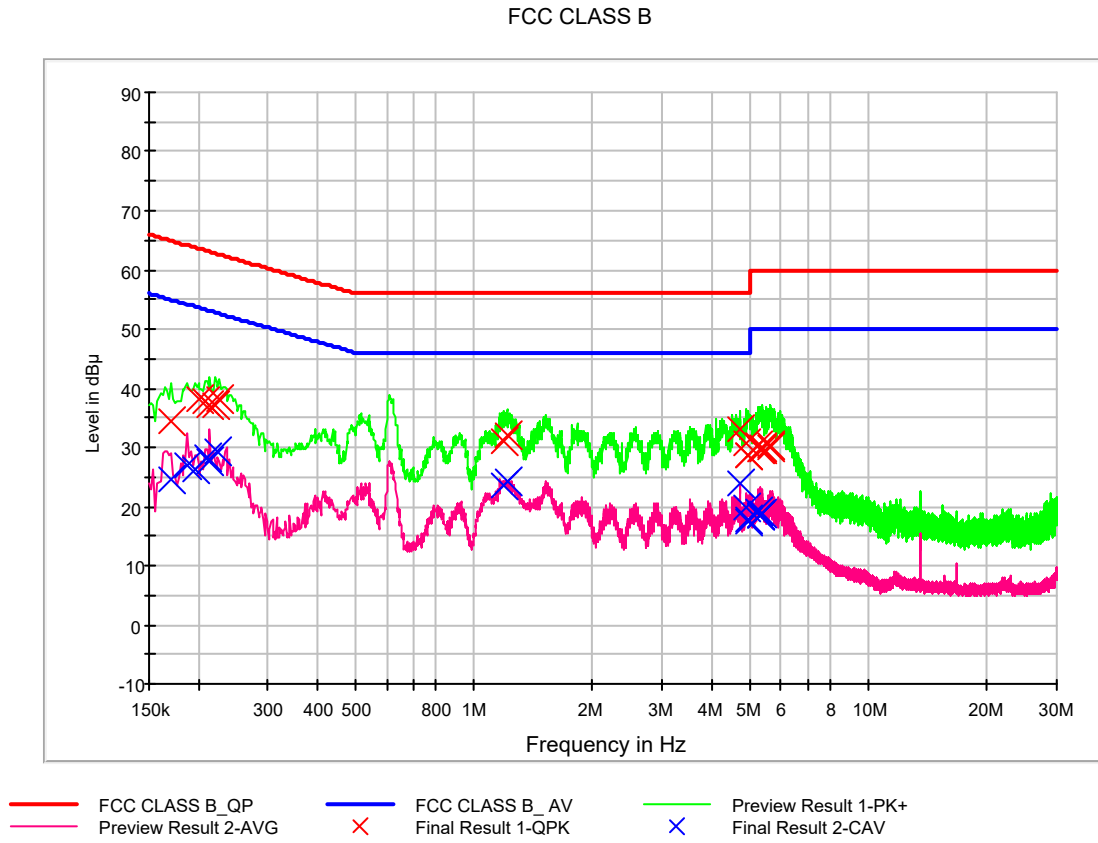



QuasiPeak Final Result, Line (L1)

Frequency (MHz)	QuasiPeak (dBuV)	Bandwidth (kHz)	Line	Corr. (dB)	Margin (dB)	Limit (dBuV)
0.170000	34.3	9.000	L1	9.6	30.6	65.0
0.200000	38.0	9.000	L1	9.7	25.6	63.6
0.208000	37.7	9.000	L1	9.7	25.6	63.3
0.214000	37.2	9.000	L1	9.7	25.8	63.0
0.220000	37.3	9.000	L1	9.7	25.5	62.8
0.226000	38.0	9.000	L1	9.6	24.6	62.6
1.188000	30.9	9.000	L1	9.7	25.1	56.0
1.212000	31.9	9.000	L1	9.7	24.1	56.0
4.716000	33.1	9.000	L1	9.8	22.9	56.0
4.914000	30.5	9.000	L1	9.8	25.5	56.0
4.944000	28.5	9.000	L1	9.8	27.5	56.0
4.968000	28.8	9.000	L1	9.8	27.2	56.0
5.248000	30.3	9.000	L1	9.8	29.7	60.0
5.286000	29.5	9.000	L1	9.9	30.5	60.0
5.352000	29.7	9.000	L1	9.9	30.3	60.0
5.358000	29.9	9.000	L1	9.9	30.1	60.0
5.630000	30.4	9.000	L1	9.9	29.6	60.0
5.650000	30.0	9.000	L1	9.9	30.0	60.0



CAverage Final Result, Line (L1)

Frequency (MHz)	CAverage (dBuV)	Bandwidth (kHz)	Line	Corr. (dB)	Margin (dB)	Limit (dBuV)
0.170000	24.7	9.000	L1	9.6	30.2	55.0
0.188000	26.8	9.000	L1	9.7	27.3	54.1
0.196000	26.3	9.000	L1	9.7	27.5	53.8
0.210000	28.2	9.000	L1	9.7	25.0	53.2
0.214000	27.5	9.000	L1	9.7	25.6	53.0
0.224000	29.3	9.000	L1	9.7	23.4	52.7
1.188000	23.5	9.000	L1	9.7	22.5	46.0
1.212000	24.3	9.000	L1	9.7	21.7	46.0
4.716000	23.9	9.000	L1	9.8	22.1	46.0
4.914000	19.9	9.000	L1	9.8	26.1	46.0
4.944000	17.5	9.000	L1	9.8	28.5	46.0
4.968000	17.8	9.000	L1	9.8	28.2	46.0
5.248000	19.0	9.000	L1	9.8	31.0	50.0
5.286000	18.6	9.000	L1	9.9	31.4	50.0
5.290000	18.4	9.000	L1	9.9	31.6	50.0
5.298000	18.3	9.000	L1	9.9	31.7	50.0
5.328000	18.5	9.000	L1	9.9	31.5	50.0
5.358000	18.8	9.000	L1	9.9	31.2	50.0



Figure 4: Conducted Emission, Charging + CDMA BC1 RX Receiving mode, Line (N)

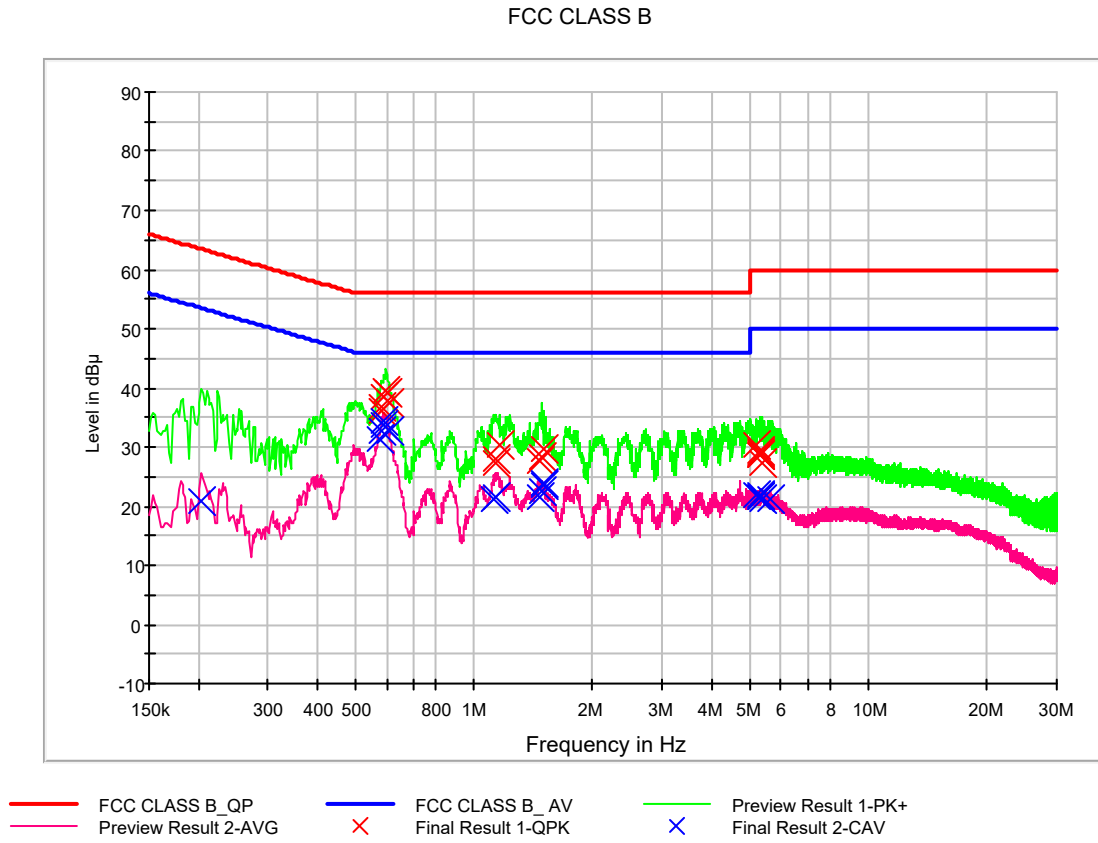



QuasiPeak Final Result, Line (N)

Frequency (MHz)	QuasiPeak (dBuV)	Bandwidth (kHz)	Line	Corr. (dB)	Margin (dB)	Limit (dBuV)
0.580000	36.0	9.000	N	9.7	20.0	56.0
0.584000	36.8	9.000	N	9.7	19.2	56.0
0.592000	38.6	9.000	N	9.7	17.4	56.0
0.598000	39.4	9.000	N	9.7	16.6	56.0
0.604000	39.1	9.000	N	9.7	16.9	56.0
0.612000	37.6	9.000	N	9.7	18.4	56.0
1.130000	27.5	9.000	N	9.7	28.5	56.0
1.136000	28.1	9.000	N	9.7	27.9	56.0
1.162000	30.5	9.000	N	9.7	25.5	56.0
1.466000	27.5	9.000	N	9.7	28.5	56.0
1.482000	28.4	9.000	N	9.7	27.6	56.0
1.498000	29.7	9.000	N	9.7	26.3	56.0
5.220000	30.2	9.000	N	9.8	29.8	60.0
5.292000	29.2	9.000	N	9.8	30.8	60.0
5.306000	29.1	9.000	N	9.8	30.9	60.0
5.314000	28.8	9.000	N	9.8	31.2	60.0
5.328000	28.7	9.000	N	9.8	31.3	60.0
5.368000	27.4	9.000	N	9.8	32.6	60.0



CAverage Final Result, Line (N)

Frequency (MHz)	CAverage (dBuV)	Bandwidth (kHz)	Line	Corr. (dB)	Margin (dB)	Limit (dBuV)
0.204000	20.8	9.000	N	9.6	32.6	53.4
0.576000	31.3	9.000	N	9.7	14.7	46.0
0.584000	32.9	9.000	N	9.7	13.1	46.0
0.588000	33.7	9.000	N	9.7	12.3	46.0
0.592000	34.5	9.000	N	9.7	11.5	46.0
0.610000	32.7	9.000	N	9.7	13.3	46.0
1.122000	21.2	9.000	N	9.7	24.8	46.0
1.130000	21.6	9.000	N	9.7	24.4	46.0
1.466000	21.4	9.000	N	9.7	24.6	46.0
1.480000	22.4	9.000	N	9.7	23.6	46.0
1.498000	23.7	9.000	N	9.7	22.3	46.0
1.502000	24.0	9.000	N	9.7	22.0	46.0
5.220000	21.8	9.000	N	9.8	28.2	50.0
5.292000	21.8	9.000	N	9.8	28.2	50.0
5.314000	21.6	9.000	N	9.8	28.4	50.0
5.334000	21.4	9.000	N	9.8	28.6	50.0
5.368000	21.0	9.000	N	9.8	29.0	50.0
5.662000	21.1	9.000	N	9.9	28.9	50.0



Figure 5: Conducted Emission, Charging + LTE BAND 5 RX Receiving mode, Line (L1)

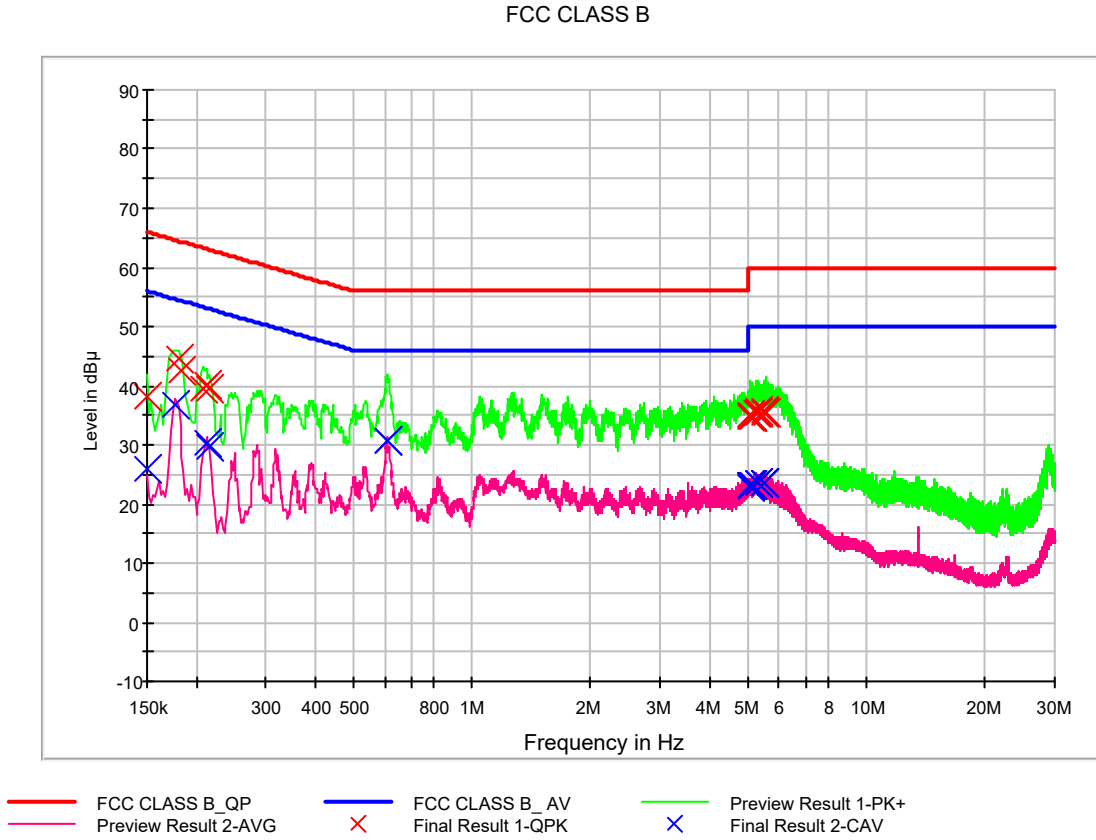



QuasiPeak Final Result, Line (L1)

Frequency (MHz)	QuasiPeak (dBuV)	Bandwidth (kHz)	Line	Corr. (dB)	Margin (dB)	Limit (dBuV)
0.150000	38.3	9.000	L1	9.6	27.7	66.0
0.180000	44.5	9.000	L1	9.6	20.0	64.5
0.184000	42.4	9.000	L1	9.6	21.9	64.3
0.208000	39.5	9.000	L1	9.7	23.8	63.3
0.212000	40.3	9.000	L1	9.7	22.8	63.1
0.216000	39.5	9.000	L1	9.7	23.4	63.0
5.082000	34.9	9.000	L1	9.8	25.1	60.0
5.092000	34.9	9.000	L1	9.8	25.1	60.0
5.104000	34.8	9.000	L1	9.8	25.2	60.0
5.108000	34.6	9.000	L1	9.8	25.4	60.0
5.112000	34.8	9.000	L1	9.8	25.2	60.0
5.116000	34.8	9.000	L1	9.8	25.2	60.0
5.262000	35.4	9.000	L1	9.9	24.6	60.0
5.300000	35.5	9.000	L1	9.9	24.5	60.0
5.308000	35.6	9.000	L1	9.9	24.4	60.0
5.530000	35.6	9.000	L1	9.9	24.4	60.0
5.534000	35.4	9.000	L1	9.9	24.6	60.0
5.554000	35.4	9.000	L1	9.9	24.6	60.0



CAverage Final Result, Line (L1)

Frequency (MHz)	CAverage (dBuV)	Bandwidth (kHz)	Line	Corr. (dB)	Margin (dB)	Limit (dBuV)
0.150000	25.8	9.000	L1	9.6	30.2	56.0
0.176000	36.8	9.000	L1	9.6	17.9	54.7
0.212000	30.3	9.000	L1	9.7	22.8	53.1
0.216000	29.7	9.000	L1	9.7	23.3	53.0
0.608000	30.7	9.000	L1	9.7	15.3	46.0
0.612000	30.8	9.000	L1	9.7	15.2	46.0
5.070000	23.1	9.000	L1	9.8	26.9	50.0
5.084000	23.0	9.000	L1	9.8	27.0	50.0
5.092000	23.2	9.000	L1	9.8	26.8	50.0
5.104000	23.2	9.000	L1	9.8	26.8	50.0
5.108000	23.3	9.000	L1	9.8	26.7	50.0
5.112000	23.3	9.000	L1	9.8	26.7	50.0
5.290000	23.7	9.000	L1	9.9	26.3	50.0
5.308000	23.6	9.000	L1	9.9	26.4	50.0
5.496000	23.6	9.000	L1	9.9	26.4	50.0
5.522000	23.4	9.000	L1	9.9	26.6	50.0
5.530000	23.5	9.000	L1	9.9	26.5	50.0
5.534000	23.4	9.000	L1	9.9	26.6	50.0



Figure 6: Conducted Emission, Charging + LTE BAND 5 RX Receiving mode, Line (N)

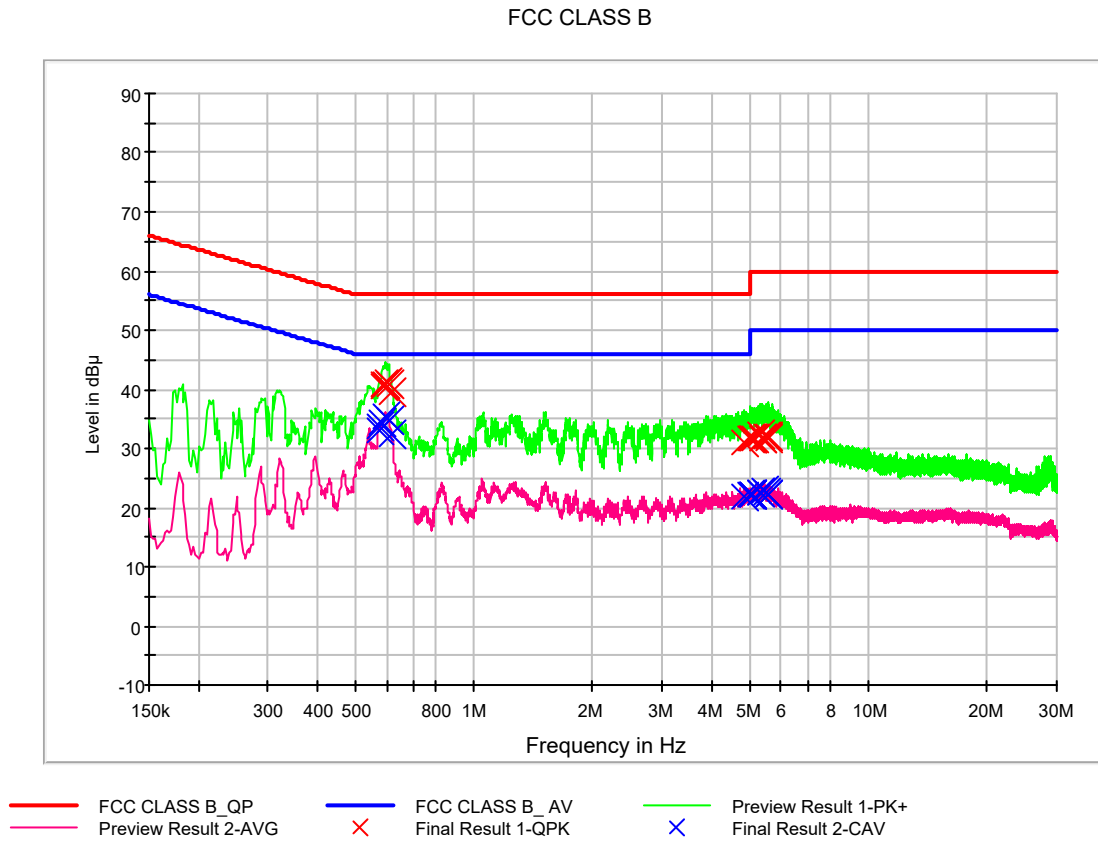



QuasiPeak Final Result, Line (N)

Frequency (MHz)	QuasiPeak (dBuV)	Bandwidth (kHz)	Line	Corr. (dB)	Margin (dB)	Limit (dBuV)
0.586000	40.9	9.000	N	9.7	15.1	56.0
0.590000	40.5	9.000	N	9.7	15.5	56.0
0.596000	40.8	9.000	N	9.7	15.2	56.0
0.604000	41.3	9.000	N	9.7	14.7	56.0
0.608000	41.0	9.000	N	9.7	15.0	56.0
0.616000	39.3	9.000	N	9.7	16.7	56.0
4.842000	31.2	9.000	N	9.8	24.8	56.0
5.008000	31.5	9.000	N	9.8	28.5	60.0
5.058000	31.8	9.000	N	9.8	28.2	60.0
5.062000	31.6	9.000	N	9.8	28.4	60.0
5.078000	31.8	9.000	N	9.8	28.2	60.0
5.126000	31.6	9.000	N	9.8	28.4	60.0
5.284000	32.2	9.000	N	9.8	27.8	60.0
5.358000	31.8	9.000	N	9.8	28.2	60.0
5.380000	31.6	9.000	N	9.8	28.4	60.0
5.488000	32.1	9.000	N	9.8	27.9	60.0
5.540000	32.0	9.000	N	9.9	28.0	60.0
5.572000	31.7	9.000	N	9.9	28.3	60.0



CAverage Final Result, Line (N)

Frequency (MHz)	CAverage (dBuV)	Bandwidth (kHz)	Line	Corr. (dB)	Margin (dB)	Limit (dBuV)
0.574000	33.2	9.000	N	9.7	12.8	46.0
0.578000	33.9	9.000	N	9.7	12.1	46.0
0.582000	34.3	9.000	N	9.7	11.7	46.0
0.596000	35.5	9.000	N	9.7	10.5	46.0
0.610000	34.7	9.000	N	9.7	11.3	46.0
0.618000	32.5	9.000	N	9.7	13.5	46.0
4.842000	21.7	9.000	N	9.8	24.3	46.0
5.020000	22.3	9.000	N	9.8	27.7	50.0
5.058000	22.3	9.000	N	9.8	27.7	50.0
5.062000	22.1	9.000	N	9.8	27.9	50.0
5.078000	22.3	9.000	N	9.8	27.7	50.0
5.086000	22.3	9.000	N	9.8	27.7	50.0
5.284000	22.6	9.000	N	9.8	27.4	50.0
5.314000	22.7	9.000	N	9.8	27.3	50.0
5.440000	22.8	9.000	N	9.8	27.2	50.0
5.488000	22.6	9.000	N	9.8	27.4	50.0
5.572000	22.3	9.000	N	9.9	27.7	50.0
5.576000	22.2	9.000	N	9.9	27.8	50.0



Figure 7: Conducted Emission, Charging + LTE BAND 12 RX Receiving mode, Line (L1)

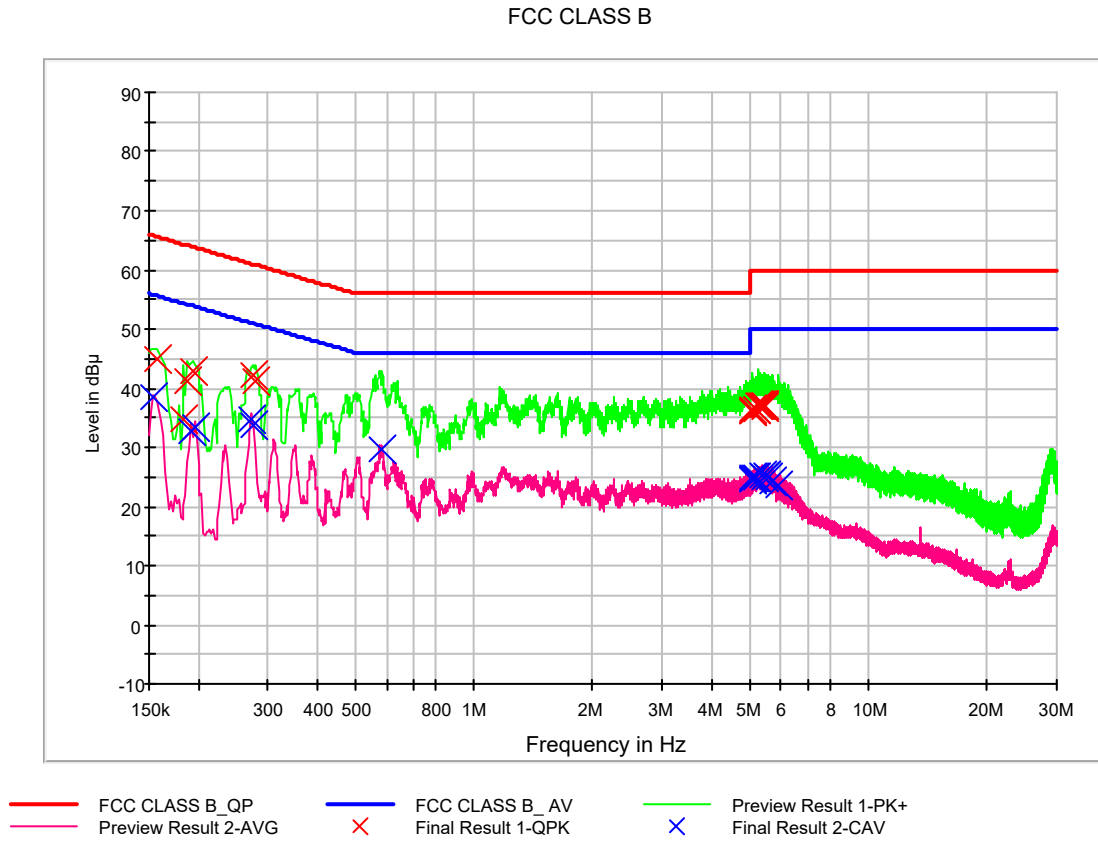



QuasiPeak Final Result, Line (L1)

Frequency (MHz)	QuasiPeak (dBuV)	Bandwidth (kHz)	Line	Corr. (dB)	Margin (dB)	Limit (dBuV)
0.158000	45.0	9.000	L1	9.6	20.6	65.6
0.184000	34.8	9.000	L1	9.6	29.5	64.3
0.188000	41.1	9.000	L1	9.7	23.0	64.1
0.194000	42.9	9.000	L1	9.7	21.0	63.9
0.274000	42.4	9.000	L1	9.6	18.6	61.0
0.280000	41.1	9.000	L1	9.6	19.8	60.8
5.062000	36.2	9.000	L1	9.8	23.8	60.0
5.072000	36.2	9.000	L1	9.8	23.8	60.0
5.076000	36.2	9.000	L1	9.8	23.8	60.0
5.098000	36.4	9.000	L1	9.8	23.6	60.0
5.194000	36.5	9.000	L1	9.8	23.5	60.0
5.202000	36.6	9.000	L1	9.8	23.4	60.0
5.282000	37.2	9.000	L1	9.9	22.8	60.0
5.294000	37.0	9.000	L1	9.9	23.0	60.0
5.380000	37.1	9.000	L1	9.9	22.9	60.0
5.416000	36.8	9.000	L1	9.9	23.2	60.0
5.424000	37.2	9.000	L1	9.9	22.8	60.0
5.464000	37.1	9.000	L1	9.9	22.9	60.0



CAverage Final Result, Line (L1)

Frequency (MHz)	CAverage (dBuV)	Bandwidth (kHz)	Line	Corr. (dB)	Margin (dB)	Limit (dBuV)
0.154000	38.5	9.000	L1	9.6	17.3	55.8
0.192000	32.8	9.000	L1	9.7	21.1	53.9
0.196000	33.3	9.000	L1	9.7	20.5	53.8
0.272000	34.7	9.000	L1	9.6	16.4	51.1
0.276000	33.6	9.000	L1	9.6	17.3	50.9
0.580000	29.8	9.000	L1	9.7	16.2	46.0
5.064000	24.6	9.000	L1	9.8	25.4	50.0
5.072000	24.7	9.000	L1	9.8	25.3	50.0
5.076000	24.7	9.000	L1	9.8	25.3	50.0
5.098000	24.8	9.000	L1	9.8	25.2	50.0
5.152000	24.8	9.000	L1	9.8	25.2	50.0
5.166000	24.7	9.000	L1	9.8	25.3	50.0
5.380000	25.1	9.000	L1	9.9	24.9	50.0
5.464000	24.9	9.000	L1	9.9	25.1	50.0
5.502000	25.1	9.000	L1	9.9	24.9	50.0
5.544000	24.9	9.000	L1	9.9	25.1	50.0
5.722000	24.4	9.000	L1	9.9	25.6	50.0
5.894000	23.5	9.000	L1	9.9	26.5	50.0



Figure 8: Conducted Emission, Charging + LTE BAND 12 RX Receiving mode, Line (N)

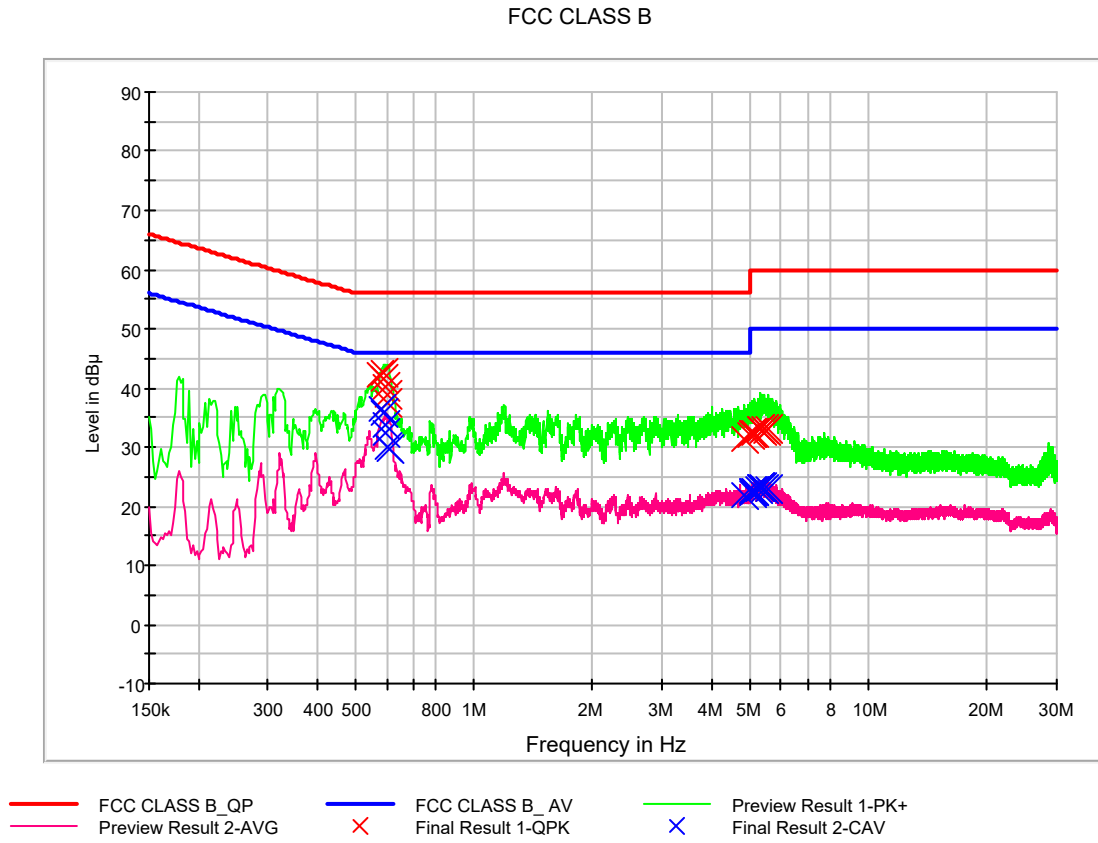



QuasiPeak Final Result, Line (N)

Frequency (MHz)	QuasiPeak (dBuV)	Bandwidth (kHz)	Line	Corr. (dB)	Margin (dB)	Limit (dBuV)
0.578000	42.2	9.000	N	9.7	13.8	56.0
0.586000	42.4	9.000	N	9.7	13.6	56.0
0.592000	41.4	9.000	N	9.7	14.6	56.0
0.596000	40.3	9.000	N	9.7	15.7	56.0
0.600000	38.8	9.000	N	9.7	17.2	56.0
0.606000	37.6	9.000	N	9.7	18.4	56.0
4.864000	31.5	9.000	N	9.8	24.5	56.0
5.024000	32.0	9.000	N	9.8	28.0	60.0
5.042000	32.4	9.000	N	9.8	27.6	60.0
5.058000	32.3	9.000	N	9.8	27.7	60.0
5.076000	32.4	9.000	N	9.8	27.6	60.0
5.118000	32.5	9.000	N	9.8	27.5	60.0
5.304000	33.0	9.000	N	9.8	27.0	60.0
5.332000	32.9	9.000	N	9.8	27.1	60.0
5.392000	32.8	9.000	N	9.8	27.2	60.0
5.426000	32.9	9.000	N	9.8	27.1	60.0
5.528000	32.7	9.000	N	9.9	27.3	60.0
5.552000	32.9	9.000	N	9.9	27.1	60.0



CAverage Final Result, Line (N)

Frequency (MHz)	CAverage (dBuV)	Bandwidth (kHz)	Line	Corr. (dB)	Margin (dB)	Limit (dBuV)
0.580000	36.5	9.000	N	9.7	9.5	46.0
0.588000	35.9	9.000	N	9.7	10.1	46.0
0.594000	33.7	9.000	N	9.7	12.3	46.0
0.598000	32.5	9.000	N	9.7	13.5	46.0
0.606000	29.9	9.000	N	9.7	16.1	46.0
0.612000	29.8	9.000	N	9.7	16.2	46.0
4.848000	21.8	9.000	N	9.8	24.2	46.0
5.042000	22.3	9.000	N	9.8	27.7	50.0
5.076000	22.6	9.000	N	9.8	27.4	50.0
5.094000	22.6	9.000	N	9.8	27.4	50.0
5.118000	22.7	9.000	N	9.8	27.3	50.0
5.122000	22.6	9.000	N	9.8	27.4	50.0
5.274000	22.9	9.000	N	9.8	27.1	50.0
5.304000	23.2	9.000	N	9.8	26.8	50.0
5.312000	23.1	9.000	N	9.8	26.9	50.0
5.392000	23.1	9.000	N	9.8	26.9	50.0
5.426000	23.0	9.000	N	9.8	27.0	50.0
5.552000	22.8	9.000	N	9.9	27.2	50.0



Figure 9: Conducted Emission, Charging + LTE BAND 25 RX Receiving mode, Line (L1)

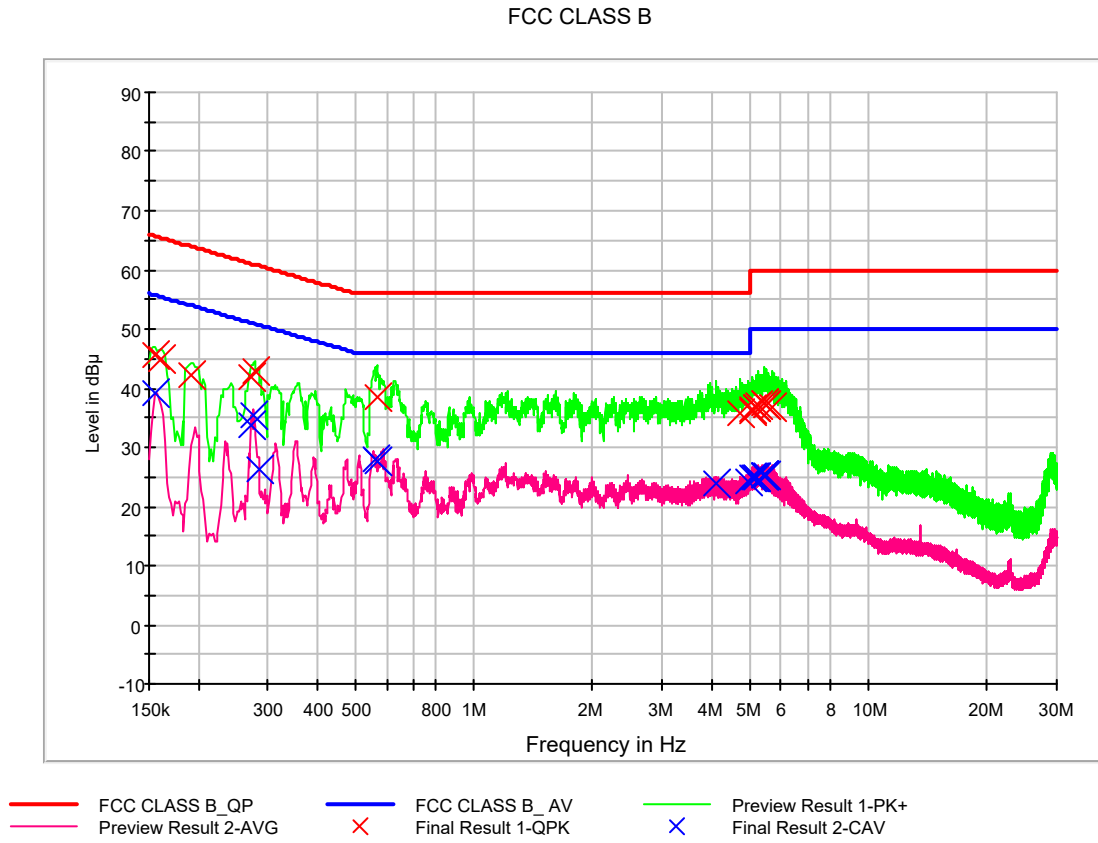



QuasiPeak Final Result, Line (L1)

Frequency (MHz)	QuasiPeak (dBuV)	Bandwidth (kHz)	Line	Corr. (dB)	Margin (dB)	Limit (dBuV)
0.156000	45.7	9.000	L1	9.6	20.0	65.7
0.160000	45.0	9.000	L1	9.6	20.5	65.5
0.192000	42.2	9.000	L1	9.7	21.8	63.9
0.272000	41.8	9.000	L1	9.6	19.3	61.1
0.278000	42.8	9.000	L1	9.6	18.1	60.9
0.566000	38.6	9.000	L1	9.7	17.4	56.0
4.718000	35.9	9.000	L1	9.8	20.1	56.0
5.086000	36.1	9.000	L1	9.8	23.9	60.0
5.092000	36.5	9.000	L1	9.8	23.5	60.0
5.172000	36.7	9.000	L1	9.8	23.3	60.0
5.182000	36.7	9.000	L1	9.8	23.3	60.0
5.186000	36.8	9.000	L1	9.8	23.2	60.0
5.266000	37.2	9.000	L1	9.9	22.8	60.0
5.418000	37.4	9.000	L1	9.9	22.6	60.0
5.462000	37.6	9.000	L1	9.9	22.4	60.0
5.474000	37.2	9.000	L1	9.9	22.8	60.0
5.510000	37.2	9.000	L1	9.9	22.8	60.0
5.684000	36.7	9.000	L1	9.9	23.3	60.0



CAverage Final Result, Line (L1)

Frequency (MHz)	CAverage (dBuV)	Bandwidth (kHz)	Line	Corr. (dB)	Margin (dB)	Limit (dBuV)
0.156000	39.0	9.000	L1	9.6	16.7	55.7
0.272000	33.6	9.000	L1	9.6	17.4	51.1
0.276000	35.5	9.000	L1	9.6	15.5	50.9
0.284000	26.4	9.000	L1	9.6	24.3	50.7
0.562000	28.1	9.000	L1	9.7	17.9	46.0
0.566000	27.7	9.000	L1	9.7	18.3	46.0
4.126000	23.7	9.000	L1	9.8	22.3	46.0
4.980000	24.2	9.000	L1	9.8	21.8	46.0
5.092000	24.8	9.000	L1	9.8	25.2	50.0
5.108000	24.9	9.000	L1	9.8	25.1	50.0
5.172000	24.9	9.000	L1	9.8	25.1	50.0
5.180000	25.0	9.000	L1	9.8	25.0	50.0
5.408000	25.2	9.000	L1	9.9	24.8	50.0
5.416000	25.2	9.000	L1	9.9	24.8	50.0
5.454000	25.3	9.000	L1	9.9	24.7	50.0
5.462000	25.3	9.000	L1	9.9	24.7	50.0
5.466000	25.4	9.000	L1	9.9	24.6	50.0
5.474000	25.3	9.000	L1	9.9	24.7	50.0



Figure 10: Conducted Emission, Charging + LTE BAND 25 RX Receiving mode, Line (N)

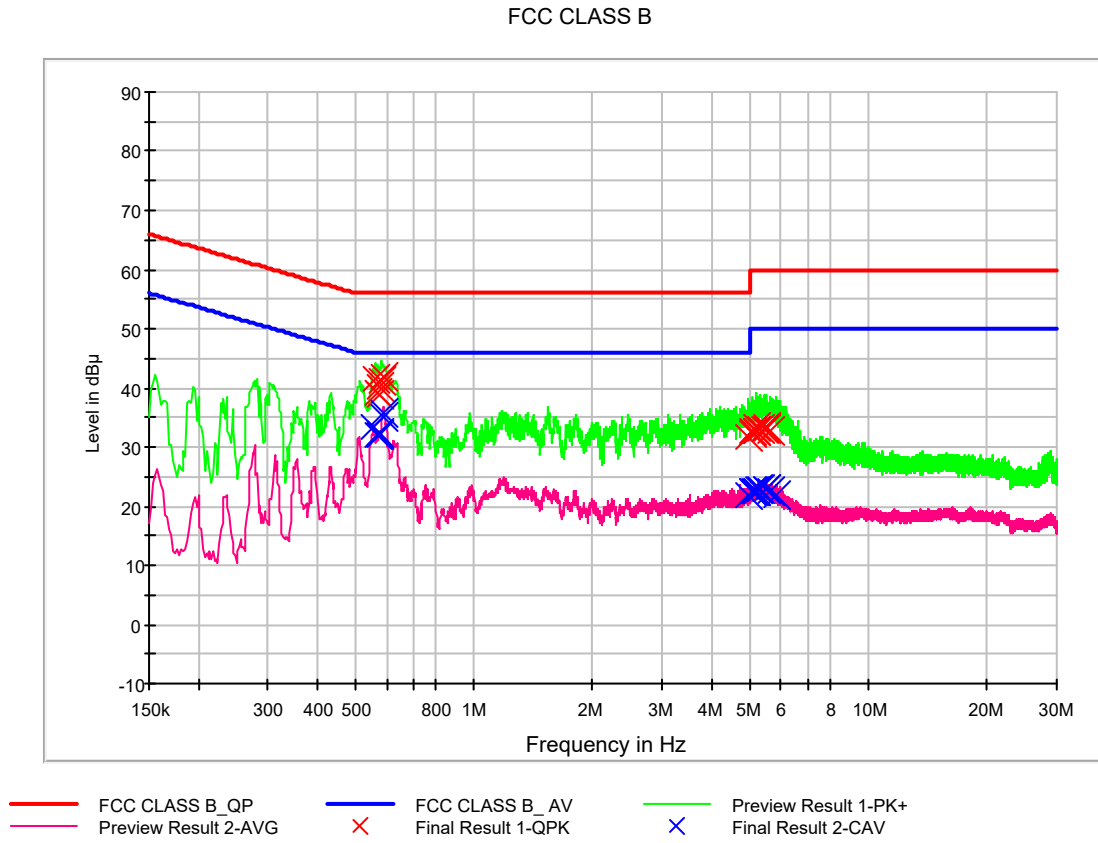



QuasiPeak Final Result, Line (N)

Frequency (MHz)	QuasiPeak (dBuV)	Bandwidth (kHz)	Line	Corr. (dB)	Margin (dB)	Limit (dBuV)
0.560000	41.4	9.000	N	9.7	14.6	56.0
0.568000	39.1	9.000	N	9.7	16.9	56.0
0.574000	38.8	9.000	N	9.7	17.2	56.0
0.578000	40.3	9.000	N	9.7	15.7	56.0
0.582000	41.3	9.000	N	9.7	14.7	56.0
0.586000	41.9	9.000	N	9.7	14.1	56.0
4.958000	31.7	9.000	N	9.8	24.3	56.0
5.042000	32.4	9.000	N	9.8	27.6	60.0
5.092000	32.6	9.000	N	9.8	27.4	60.0
5.164000	32.7	9.000	N	9.8	27.3	60.0
5.182000	32.6	9.000	N	9.8	27.4	60.0
5.192000	32.7	9.000	N	9.8	27.3	60.0
5.198000	33.2	9.000	N	9.8	26.8	60.0
5.320000	33.0	9.000	N	9.8	27.0	60.0
5.470000	33.2	9.000	N	9.8	26.8	60.0
5.476000	33.2	9.000	N	9.8	26.8	60.0
5.488000	32.9	9.000	N	9.8	27.1	60.0
5.632000	32.8	9.000	N	9.9	27.2	60.0



CAverage Final Result, Line (N)

Frequency (MHz)	CAverage (dBuV)	Bandwidth (kHz)	Line	Corr. (dB)	Margin (dB)	Limit (dBuV)
0.556000	33.3	9.000	N	9.7	12.7	46.0
0.566000	32.1	9.000	N	9.7	13.9	46.0
0.574000	32.1	9.000	N	9.7	13.9	46.0
0.578000	32.5	9.000	N	9.7	13.5	46.0
0.586000	35.2	9.000	N	9.7	10.8	46.0
0.590000	35.9	9.000	N	9.7	10.1	46.0
4.958000	21.8	9.000	N	9.8	24.2	46.0
5.042000	22.5	9.000	N	9.8	27.5	50.0
5.092000	22.5	9.000	N	9.8	27.5	50.0
5.142000	22.4	9.000	N	9.8	27.6	50.0
5.164000	22.4	9.000	N	9.8	27.6	50.0
5.198000	22.6	9.000	N	9.8	27.4	50.0
5.278000	22.9	9.000	N	9.8	27.1	50.0
5.320000	22.9	9.000	N	9.8	27.1	50.0
5.476000	23.0	9.000	N	9.8	27.0	50.0
5.488000	23.0	9.000	N	9.8	27.0	50.0
5.632000	22.6	9.000	N	9.9	27.4	50.0
5.834000	21.9	9.000	N	9.9	28.1	50.0



Figure 11: Conducted Emission, Charging + LTE BAND 41 RX Receiving mode, Line (L1)

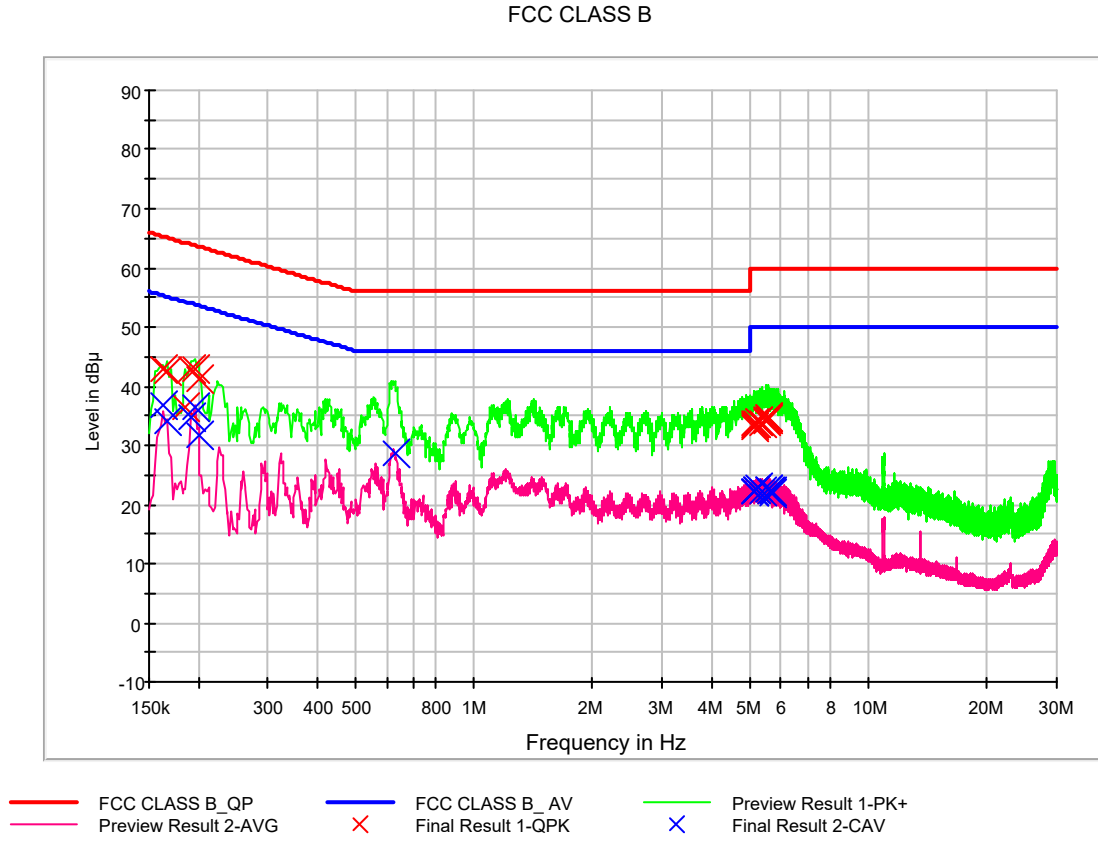



QuasiPeak Final Result, Line (L1)

Frequency (MHz)	QuasiPeak (dBuV)	Bandwidth (kHz)	Line	Corr. (dB)	Margin (dB)	Limit (dBuV)
0.162000	43.0	9.000	L1	9.6	22.4	65.4
0.166000	42.4	9.000	L1	9.6	22.8	65.2
0.186000	36.4	9.000	L1	9.7	27.8	64.2
0.192000	42.9	9.000	L1	9.7	21.0	63.9
0.196000	43.0	9.000	L1	9.7	20.7	63.8
0.200000	41.1	9.000	L1	9.7	22.6	63.6
5.102000	33.7	9.000	L1	9.8	26.3	60.0
5.126000	33.2	9.000	L1	9.8	26.8	60.0
5.156000	33.0	9.000	L1	9.8	27.0	60.0
5.220000	33.8	9.000	L1	9.8	26.2	60.0
5.226000	34.0	9.000	L1	9.8	26.0	60.0
5.238000	34.2	9.000	L1	9.8	25.8	60.0
5.376000	33.8	9.000	L1	9.9	26.2	60.0
5.500000	34.1	9.000	L1	9.9	25.9	60.0
5.504000	34.4	9.000	L1	9.9	25.6	60.0
5.546000	34.8	9.000	L1	9.9	25.2	60.0
5.586000	34.7	9.000	L1	9.9	25.3	60.0
5.598000	34.5	9.000	L1	9.9	25.5	60.0



CAverage Final Result, Line (L1)

Frequency (MHz)	CAverage (dBuV)	Bandwidth (kHz)	Line	Corr. (dB)	Margin (dB)	Limit (dBuV)
0.162000	36.7	9.000	L1	9.6	18.6	55.4
0.166000	34.2	9.000	L1	9.6	21.0	55.2
0.192000	34.9	9.000	L1	9.7	19.1	53.9
0.196000	36.3	9.000	L1	9.7	17.5	53.8
0.200000	31.5	9.000	L1	9.7	22.1	53.6
0.630000	28.7	9.000	L1	9.7	17.3	46.0
5.102000	22.3	9.000	L1	9.8	27.7	50.0
5.126000	22.3	9.000	L1	9.8	27.7	50.0
5.156000	22.2	9.000	L1	9.8	27.8	50.0
5.216000	22.6	9.000	L1	9.8	27.4	50.0
5.220000	22.5	9.000	L1	9.8	27.5	50.0
5.224000	22.8	9.000	L1	9.8	27.2	50.0
5.376000	22.4	9.000	L1	9.9	27.6	50.0
5.586000	22.4	9.000	L1	9.9	27.6	50.0
5.598000	22.5	9.000	L1	9.9	27.5	50.0
5.608000	22.3	9.000	L1	9.9	27.7	50.0
5.670000	22.1	9.000	L1	9.9	27.9	50.0
5.690000	21.9	9.000	L1	9.9	28.1	50.0



Figure 12: Conducted Emission, Charging + LTE BAND 41 RX Receiving mode, Line (N)

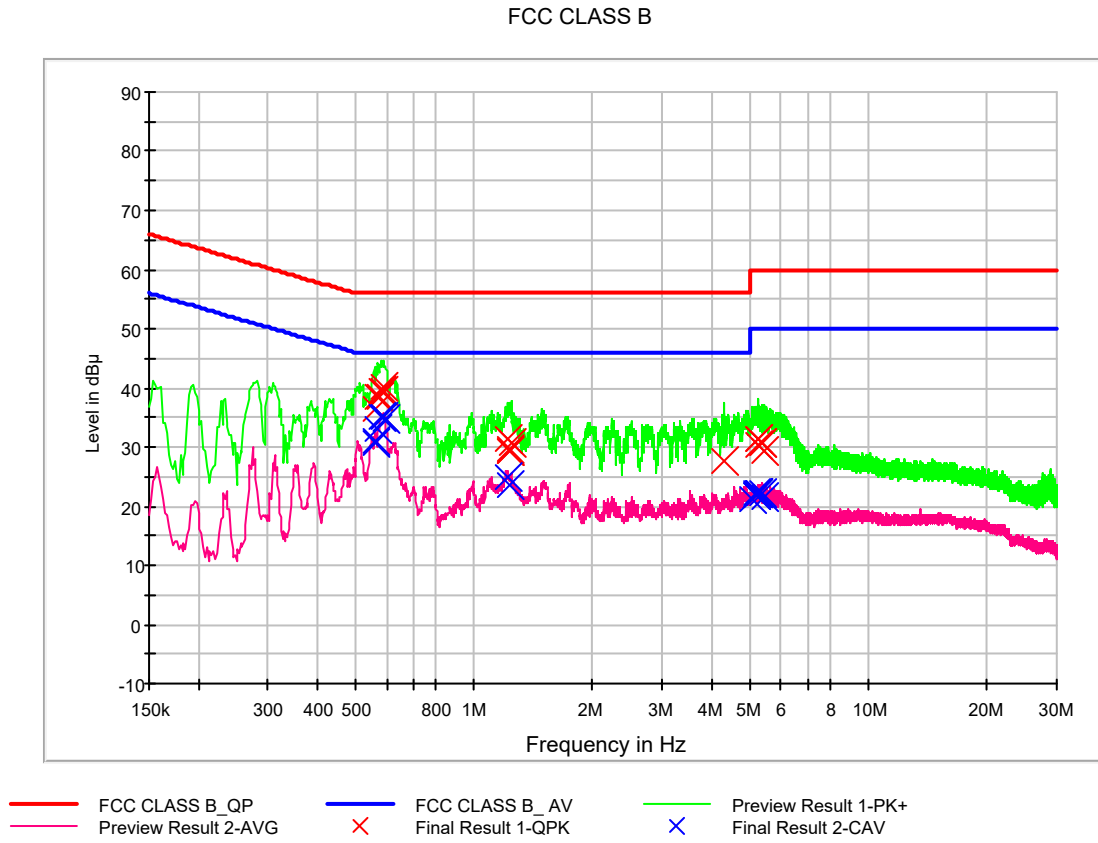



QuasiPeak Final Result, Line (N)

Frequency (MHz)	QuasiPeak (dBuV)	Bandwidth (kHz)	Line	Corr. (dB)	Margin (dB)	Limit (dBuV)
0.560000	36.4	9.000	N	9.7	19.6	56.0
0.572000	38.3	9.000	N	9.7	17.7	56.0
0.576000	38.6	9.000	N	9.7	17.4	56.0
0.582000	39.4	9.000	N	9.7	16.6	56.0
0.586000	40.1	9.000	N	9.7	15.9	56.0
0.590000	39.7	9.000	N	9.7	16.3	56.0
1.222000	31.5	9.000	N	9.7	24.5	56.0
1.228000	29.3	9.000	N	9.7	26.7	56.0
1.234000	29.8	9.000	N	9.7	26.2	56.0
1.238000	29.2	9.000	N	9.7	26.8	56.0
1.246000	30.6	9.000	N	9.7	25.4	56.0
4.294000	27.8	9.000	N	9.8	28.2	56.0
5.244000	31.3	9.000	N	9.8	28.7	60.0
5.256000	31.2	9.000	N	9.8	28.8	60.0
5.260000	30.3	9.000	N	9.8	29.7	60.0
5.370000	30.5	9.000	N	9.8	29.5	60.0
5.380000	30.7	9.000	N	9.8	29.3	60.0
5.462000	29.3	9.000	N	9.8	30.7	60.0



CAverage Final Result, Line (N)

Frequency (MHz)	CAverage (dBuV)	Bandwidth (kHz)	Line	Corr. (dB)	Margin (dB)	Limit (dBuV)
0.560000	31.1	9.000	N	9.7	14.9	46.0
0.564000	30.8	9.000	N	9.7	15.2	46.0
0.572000	33.1	9.000	N	9.7	12.9	46.0
0.582000	35.0	9.000	N	9.7	11.0	46.0
0.586000	35.1	9.000	N	9.7	10.9	46.0
0.596000	34.8	9.000	N	9.7	11.2	46.0
1.224000	24.9	9.000	N	9.7	21.1	46.0
1.228000	23.4	9.000	N	9.7	22.6	46.0
5.062000	21.2	9.000	N	9.8	28.8	50.0
5.168000	22.0	9.000	N	9.8	28.0	50.0
5.176000	22.0	9.000	N	9.8	28.0	50.0
5.196000	22.2	9.000	N	9.8	27.8	50.0
5.244000	22.3	9.000	N	9.8	27.7	50.0
5.252000	22.3	9.000	N	9.8	27.7	50.0
5.256000	22.3	9.000	N	9.8	27.7	50.0
5.260000	22.3	9.000	N	9.8	27.7	50.0
5.370000	22.1	9.000	N	9.8	27.9	50.0
5.462000	21.5	9.000	N	9.8	28.5	50.0



5.2 Radiated Emission

The test results of radiated emission provide the following information:

For Measurement Below 1 GHz

Rule Part / Standard	FCC PART 15 Subpart B Class B
Detector	Quasi-Peak
Bandwidth	120 kHz (6 dB)
Kind of Test Site	3 m semi anechoic chamber
Temperature	23.1 / 23.5 / 20.9 °C
Relative Humidity	44.2 / 45.0 / 42.2 %
Test Date	January 23 / January 24 / January 27, 2019

- Calculation Formula:

1. POL. H = Horizontal, POL. V = Vertical
2. QuasiPeak = Reading (Receiver Reading) + Corr.
3. Corr. (Correction Factor) = Antenna Factor + Cable Loss
4. Margin = Limit - QuasiPeak



Charging + CDMA BC0 RX Receiving mode

Frequency (MHz)	Quasi Peak (dB μ V/m)	Antenna Height (cm)	POL. (H/V)	Azimuth (deg)	Corr. (dB)	Margin (dB)	Limit (dB μ V/m)
34.564800	18.4	125.2	V	77.0	18.8	21.6	40.0
56.973600	19.8	99.9	V	351.0	19.8	20.2	40.0
67.532800	22.5	117.7	V	77.0	18.5	17.5	40.0
98.262400	23.1	125.3	V	288.0	15.2	20.4	43.5
137.492800	20.3	99.8	V	305.0	19.5	23.2	43.5
701.049600	28.6	174.7	V	4.0	28.8	17.4	46.0

Charging + CDMA BC1 RX Receiving mode

Frequency (MHz)	Quasi Peak (dB μ V/m)	Antenna Height (cm)	POL. (H/V)	Azimuth (deg)	Corr. (dB)	Margin (dB)	Limit (dB μ V/m)
39.696800	20.9	99.8	V	125.0	19.9	19.1	40.0
52.729600	18.8	99.8	V	177.0	20.2	21.2	40.0
66.792000	21.6	99.8	V	23.0	18.6	18.4	40.0
98.105600	20.6	99.8	V	211.0	15.2	22.9	43.5
128.219200	20.7	99.9	V	245.0	18.5	22.8	43.5
491.208800	23.9	293.8	V	170.0	25.1	22.1	46.0

Charging + LTE BAND 5 RX Receiving mode

Frequency (MHz)	Quasi Peak (dB μ V/m)	Antenna Height (cm)	POL. (H/V)	Azimuth (deg)	Corr. (dB)	Margin (dB)	Limit (dB μ V/m)
31.802400	23.0	99.8	V	128.0	18.5	17.0	40.0
53.881600	22.1	99.8	V	334.0	20.1	17.9	40.0
124.934400	25.2	99.8	V	237.0	18.2	18.3	43.5
137.724800	26.3	99.8	V	269.0	19.5	17.2	43.5
381.418400	21.4	117.8	V	110.0	22.5	24.6	46.0
677.666400	28.2	291.7	H	250.0	28.5	17.8	46.0



Charging + LTE BAND 12 RX Receiving mode

Frequency (MHz)	Quasi Peak (dB μ V/m)	Antenna Height (cm)	POL. (H/V)	Azimuth (deg)	Corr. (dB)	Margin (dB)	Limit (dB μ V/m)
34.280000	19.7	175.0	V	343.0	18.7	20.3	40.0
51.325600	23.6	115.8	V	225.0	20.3	16.4	40.0
66.476000	21.0	99.8	V	332.0	18.7	19.0	40.0
101.411200	23.3	116.8	V	212.0	15.6	20.2	43.5
123.368000	26.1	99.9	V	221.0	18.0	17.4	43.5
137.446400	25.1	99.8	V	0.0	19.5	18.4	43.5

Charging + LTE BAND 25 RX Receiving mode

Frequency (MHz)	Quasi Peak (dB μ V/m)	Antenna Height (cm)	POL. (H/V)	Azimuth (deg)	Corr. (dB)	Margin (dB)	Limit (dB μ V/m)
34.468000	18.6	99.9	V	135.0	18.8	21.4	40.0
54.188000	19.1	99.9	V	294.0	20.0	20.9	40.0
67.364000	20.5	99.8	V	19.0	18.5	19.5	40.0
137.665600	22.4	99.8	V	278.0	19.5	21.1	43.5
249.379200	17.2	125.1	V	122.0	18.8	28.8	46.0
383.615200	23.6	99.7	H	63.0	22.6	22.4	46.0

Charging + LTE BAND 41 RX Receiving mode

Frequency (MHz)	Quasi Peak (dB μ V/m)	Antenna Height (cm)	POL. (H/V)	Azimuth (deg)	Corr. (dB)	Margin (dB)	Limit (dB μ V/m)
38.242400	18.5	274.9	V	167.0	19.6	21.5	40.0
49.336000	17.9	174.7	V	265.0	20.4	22.1	40.0
66.648000	21.9	99.9	V	253.0	18.6	18.1	40.0
138.230400	22.2	99.8	V	101.0	19.6	21.3	43.5
339.899200	19.7	274.8	V	174.0	21.4	26.3	46.0
676.892000	28.1	116.7	H	0.0	28.4	17.9	46.0



CDMA BC0 RX Receiving mode

Frequency (MHz)	Quasi Peak (dB μ V/m)	Antenna Height (cm)	POL. (H/V)	Azimuth (deg)	Corr. (dB)	Margin (dB)	Limit (dB μ V/m)
58.641600	17.2	99.8	V	13.0	19.7	22.8	40.0
114.572000	21.4	191.7	V	217.0	17.1	22.1	43.5
161.324800	18.4	207.7	V	175.0	20.1	25.1	43.5
293.973600	18.4	325.1	V	156.0	20.3	27.6	46.0
494.107200	23.9	117.8	H	354.0	25.1	22.1	46.0
694.060000	28.4	174.9	V	354.0	28.7	17.6	46.0

CDMA BC1 RX Receiving mode

Frequency (MHz)	Quasi Peak (dB μ V/m)	Antenna Height (cm)	POL. (H/V)	Azimuth (deg)	Corr. (dB)	Margin (dB)	Limit (dB μ V/m)
42.423200	17.3	99.9	V	352.0	20.1	22.7	40.0
58.879200	17.2	99.8	V	77.0	19.6	22.8	40.0
114.544800	20.7	175.0	V	329.0	17.1	22.8	43.5
141.592800	17.5	116.7	V	242.0	19.8	26.0	43.5
238.680000	16.6	99.8	V	240.0	18.4	29.4	46.0
453.812800	23.1	119.0	V	43.0	24.5	22.9	46.0

LTE BAND 5 RX Receiving mode

Frequency (MHz)	Quasi Peak (dB μ V/m)	Antenna Height (cm)	POL. (H/V)	Azimuth (deg)	Corr. (dB)	Margin (dB)	Limit (dB μ V/m)
31.791200	16.5	174.7	V	284.0	18.5	23.5	40.0
49.916800	17.8	225.2	V	308.0	20.4	22.2	40.0
62.839200	16.8	99.9	V	87.0	19.2	23.2	40.0
67.128800	16.2	299.8	V	73.0	18.6	23.8	40.0
156.155200	18.6	99.7	V	244.0	20.1	24.9	43.5
384.040000	21.1	99.9	H	0.0	22.6	24.9	46.0



LTE BAND 12 RX Receiving mode

Frequency (MHz)	Quasi Peak (dB μ V/m)	Antenna Height (cm)	POL. (H/V)	Azimuth (deg)	Corr. (dB)	Margin (dB)	Limit (dB μ V/m)
40.546400	17.4	299.9	V	332.0	20.0	22.6	40.0
56.090400	17.3	99.9	V	44.0	19.9	22.7	40.0
114.548000	21.2	191.9	V	173.0	17.1	22.3	43.5
154.358400	18.5	99.9	V	30.0	20.1	25.0	43.5
279.576800	17.9	308.7	V	288.0	19.8	28.1	46.0
487.739200	23.9	274.9	H	198.0	25.0	22.1	46.0

LTE BAND 25 RX Receiving mode

Frequency (MHz)	Quasi Peak (dB μ V/m)	Antenna Height (cm)	POL. (H/V)	Azimuth (deg)	Corr. (dB)	Margin (dB)	Limit (dB μ V/m)
38.400000	17.0	99.8	V	323.0	19.6	23.0	40.0
49.041600	17.6	174.8	V	253.0	20.4	22.4	40.0
60.020000	17.0	207.9	V	278.0	19.5	23.0	40.0
130.464000	16.3	225.1	V	273.0	18.8	27.2	43.5
277.959200	17.8	192.9	H	53.0	19.8	28.2	46.0
494.479200	24.0	191.9	V	320.0	25.1	22.0	46.0

LTE BAND 41 RX Receiving mode

Frequency (MHz)	Quasi Peak (dB μ V/m)	Antenna Height (cm)	POL. (H/V)	Azimuth (deg)	Corr. (dB)	Margin (dB)	Limit (dB μ V/m)
39.867200	17.3	99.9	V	199.0	19.9	22.7	40.0
49.081600	17.7	191.8	V	283.0	20.4	22.3	40.0
72.282400	14.9	174.7	V	259.0	17.7	25.1	40.0
114.563200	21.5	191.8	V	216.0	17.1	22.0	43.5
165.660000	18.0	174.8	V	324.0	19.8	25.5	43.5
452.082400	22.9	225.1	H	132.0	24.4	23.1	46.0



For Measurement Above 1 GHz

Rule Part / Standard	FCC PART 15 Subpart B Class B
Detector	Peak mode: Peak (RBW: 1 MHz, VBW: 3 MHz) CISPR-Average mode: Peak (RBW: 1 MHz, VBW: 10 Hz)
Highest Operating Frequency	2 690 MHz
Tested Frequency Range	1 GHz to 18 GHz
Kind of Test Site	3 m semi anechoic chamber
Temperature	23.1 / 23.5 / 20.9 °C
Relative Humidity	44.2 / 45.0 / 42.2 %
Test Date	January 23 / January 24 / January 27, 2019

- Calculation Formula:

1. POL. H = Horizontal, POL. V = Vertical
2. Peak or CAverage = Reading (Receiver Reading) + Corr.
3. Corr. (Correction Factor) = Antenna Factor+ Cable Loss –Amplifier Gain
4. Margin = Limit - Peak or CAverage



Charging + CDMA BC0 RX Receiving mode

Frequency (MHz)	Peak (dBμV/m)	Antenna Height (cm)	POL. (H/V)	Azimuth (deg)	Corr. (dB)	Margin (dB)	Limit (dBμV/m)
2051.015000	31.5	140.6	V	154.0	-26.5	42.5	74.0
3042.695000	34.3	232.6	V	143.0	-22.8	39.7	74.0
3827.040000	34.1	159.5	H	95.0	-21.4	39.9	74.0
4689.355000	37.2	248.4	H	297.0	-19.2	36.8	74.0
6471.265000	38.8	249.9	V	340.0	-15.1	35.2	74.0
7245.205000	39.4	275.6	V	175.0	-13.7	34.6	74.0

Frequency (MHz)	CAverage (dBμV/m)	Antenna Height (cm)	POL. (H/V)	Azimuth (deg)	Corr. (dB)	Margin (dB)	Limit (dBμV/m)
2051.015000	18.7	140.6	V	154.0	-26.5	35.3	54.0
3042.695000	21.1	232.6	V	143.0	-22.8	32.9	54.0
3827.040000	21.8	159.5	H	95.0	-21.4	32.2	54.0
4689.355000	23.6	248.4	H	297.0	-19.2	30.4	54.0
6471.265000	26.4	249.9	V	340.0	-15.1	27.6	54.0
7245.205000	27.1	275.6	V	175.0	-13.7	26.9	54.0

Charging + CDMA BC1 RX Receiving mode

Frequency (MHz)	Peak (dBμV/m)	Antenna Height (cm)	POL. (H/V)	Azimuth (deg)	Corr. (dB)	Margin (dB)	Limit (dBμV/m)
2724.960000	33.3	319.5	V	190.0	-24.0	40.7	74.0
4783.920000	34.8	150.0	V	111.0	-19.0	39.2	74.0
6665.750000	38.5	217.5	V	285.0	-14.9	35.5	74.0
8750.485000	42.5	99.9	V	277.0	-12.0	31.5	74.0
10443.380000	44.2	249.6	V	295.0	-7.4	29.8	74.0
12320.075000	42.9	249.4	V	73.0	-5.5	31.1	74.0

Frequency (MHz)	CAverage (dBμV/m)	Antenna Height (cm)	POL. (H/V)	Azimuth (deg)	Corr. (dB)	Margin (dB)	Limit (dBμV/m)
2724.960000	20.2	319.5	V	190.0	-24.0	33.8	54.0
4783.920000	22.7	150.0	V	111.0	-19.0	31.3	54.0
6665.750000	26.0	217.5	V	285.0	-14.9	28.0	54.0
8750.485000	29.4	99.9	V	277.0	-12.0	24.6	54.0
10443.380000	31.5	249.6	V	295.0	-7.4	22.5	54.0
12320.075000	30.4	249.4	V	73.0	-5.5	23.6	54.0



Charging + LTE BAND 5 RX Receiving mode

Frequency (MHz)	Peak (dB μ V/m)	Antenna Height (cm)	POL. (H/V)	Azimuth (deg)	Corr. (dB)	Margin (dB)	Limit (dB μ V/m)
1828.860000	30.8	203.4	H	45.0	-27.1	43.2	74.0
2919.690000	34.0	260.4	H	55.0	-23.1	40.0	74.0
4523.975000	36.0	275.5	V	262.0	-19.5	38.0	74.0
5269.200000	36.5	190.4	V	81.0	-18.2	37.5	74.0
7555.345000	41.2	292.5	H	217.0	-12.6	32.8	74.0
9703.800000	42.6	299.4	H	137.0	-9.8	31.4	74.0

Frequency (MHz)	CAverage (dB μ V/m)	Antenna Height (cm)	POL. (H/V)	Azimuth (deg)	Corr. (dB)	Margin (dB)	Limit (dB μ V/m)
1828.860000	17.9	203.4	H	45.0	-27.1	36.1	54.0
2919.690000	20.7	260.4	H	55.0	-23.1	33.3	54.0
4523.975000	23.2	275.5	V	262.0	-19.5	30.8	54.0
5269.200000	23.9	190.4	V	81.0	-18.2	30.1	54.0
7555.345000	28.4	292.5	H	217.0	-12.6	25.6	54.0
9703.800000	30.2	299.4	H	137.0	-9.8	23.8	54.0

Charging + LTE BAND 12 RX Receiving mode

Frequency (MHz)	Peak (dB μ V/m)	Antenna Height (cm)	POL. (H/V)	Azimuth (deg)	Corr. (dB)	Margin (dB)	Limit (dB μ V/m)
4762.595000	35.4	100.0	V	126.0	-19.0	38.6	74.0
6317.340000	39.0	248.5	V	234.0	-15.8	35.0	74.0
7519.075000	41.3	150.1	H	332.0	-12.6	32.7	74.0
9161.500000	43.2	138.8	V	307.0	-10.9	30.8	74.0
11192.080000	45.6	139.6	V	71.0	-5.3	28.4	74.0
14721.450000	47.2	172.4	H	313.0	-1.4	26.8	74.0

Frequency (MHz)	CAverage (dB μ V/m)	Antenna Height (cm)	POL. (H/V)	Azimuth (deg)	Corr. (dB)	Margin (dB)	Limit (dB μ V/m)
4762.595000	22.5	100.0	V	126.0	-19.0	31.5	54.0
6317.340000	25.9	248.5	V	234.0	-15.8	28.1	54.0
7519.075000	28.4	150.1	H	332.0	-12.6	25.6	54.0
9161.500000	30.6	138.8	V	307.0	-10.9	23.4	54.0
11192.080000	32.6	139.6	V	71.0	-5.3	21.4	54.0
14721.450000	34.0	172.4	H	313.0	-1.4	20.0	54.0



Charging + LTE BAND 25 RX Receiving mode

Frequency (MHz)	Peak (dBμV/m)	Antenna Height (cm)	POL. (H/V)	Azimuth (deg)	Corr. (dB)	Margin (dB)	Limit (dBμV/m)
3465.785000	33.9	99.8	V	168.0	-22.3	40.1	74.0
5977.920000	37.9	99.8	V	221.0	-17.1	36.1	74.0
7477.760000	42.8	150.1	H	285.0	-12.7	31.2	74.0
9892.930000	43.4	261.4	V	98.0	-9.5	30.6	74.0
10973.495000	46.0	233.6	V	91.0	-5.7	28.0	74.0
14761.135000	47.0	150.0	V	0.0	-1.4	27.0	74.0

Frequency (MHz)	CAverage (dBμV/m)	Antenna Height (cm)	POL. (H/V)	Azimuth (deg)	Corr. (dB)	Margin (dB)	Limit (dBμV/m)
3465.785000	21.0	99.8	V	168.0	-22.3	33.0	54.0
5977.920000	24.5	99.8	V	221.0	-17.1	29.5	54.0
7477.760000	28.5	150.1	H	285.0	-12.7	25.5	54.0
9892.930000	31.1	261.4	V	98.0	-9.5	22.9	54.0
10973.495000	33.1	233.6	V	91.0	-5.7	20.9	54.0
14761.135000	34.2	150.0	V	0.0	-1.4	19.8	54.0

Charging + LTE BAND 41 RX Receiving mode

Frequency (MHz)	Peak (dBμV/m)	Antenna Height (cm)	POL. (H/V)	Azimuth (deg)	Corr. (dB)	Margin (dB)	Limit (dBμV/m)
3353.975000	33.8	292.5	V	134.0	-22.4	40.2	74.0
5184.090000	37.3	150.0	V	64.0	-18.3	36.7	74.0
7493.630000	41.3	204.6	H	63.0	-12.7	32.7	74.0
9887.535000	43.7	248.5	V	355.0	-9.5	30.3	74.0
11588.235000	45.1	149.8	H	123.0	-4.9	28.9	74.0
14750.755000	46.7	350.0	H	97.0	-1.4	27.3	74.0

Frequency (MHz)	CAverage (dBμV/m)	Antenna Height (cm)	POL. (H/V)	Azimuth (deg)	Corr. (dB)	Margin (dB)	Limit (dBμV/m)
3353.975000	21.1	292.5	V	134.0	-22.4	32.9	54.0
5184.090000	24.1	150.0	V	64.0	-18.3	29.9	54.0
7493.630000	28.5	204.6	H	63.0	-12.7	25.5	54.0
9887.535000	30.9	248.5	V	355.0	-9.5	23.1	54.0
11588.235000	32.5	149.8	H	123.0	-4.9	21.5	54.0
14750.755000	34.0	350.0	H	97.0	-1.4	20.0	54.0



CDMA BC0 RX Receiving mode

Frequency (MHz)	Peak (dB μ V/m)	Antenna Height (cm)	POL. (H/V)	Azimuth (deg)	Corr. (dB)	Margin (dB)	Limit (dB μ V/m)
2038.820000	31.2	110.5	V	76.0	-26.6	42.8	74.0
2999.460000	33.6	150.0	V	253.0	-22.8	40.4	74.0
4636.445000	35.8	349.8	V	240.0	-19.3	38.2	74.0
6218.760000	37.7	113.6	V	0.0	-16.2	36.3	74.0
7280.540000	40.2	249.4	V	236.0	-13.6	33.8	74.0
8808.765000	42.2	99.7	V	242.0	-11.9	31.8	74.0

Frequency (MHz)	CAverage (dB μ V/m)	Antenna Height (cm)	POL. (H/V)	Azimuth (deg)	Corr. (dB)	Margin (dB)	Limit (dB μ V/m)
2038.820000	18.6	110.5	V	76.0	-26.6	35.4	54.0
2999.460000	20.9	150.0	V	253.0	-22.8	33.1	54.0
4636.445000	23.5	349.8	V	240.0	-19.3	30.5	54.0
6218.760000	25.0	113.6	V	0.0	-16.2	29.0	54.0
7280.540000	27.6	249.4	V	236.0	-13.6	26.4	54.0
8808.765000	29.4	99.7	V	242.0	-11.9	24.6	54.0

CDMA BC1 RX Receiving mode

Frequency (MHz)	Peak (dB μ V/m)	Antenna Height (cm)	POL. (H/V)	Azimuth (deg)	Corr. (dB)	Margin (dB)	Limit (dB μ V/m)
1375.240000	31.4	249.9	V	27.0	-28.3	42.6	74.0
2984.895000	33.2	160.5	V	238.0	-22.9	40.8	74.0
4511.145000	36.4	125.7	H	71.0	-19.5	37.6	74.0
6704.345000	39.2	189.4	V	160.0	-14.9	34.8	74.0
7372.625000	41.2	350.0	H	150.0	-13.2	32.8	74.0
7985.660000	41.7	248.4	H	128.0	-12.4	32.3	74.0

Frequency (MHz)	CAverage (dB μ V/m)	Antenna Height (cm)	POL. (H/V)	Azimuth (deg)	Corr. (dB)	Margin (dB)	Limit (dB μ V/m)
1375.240000	19.4	249.9	V	27.0	-28.3	34.6	54.0
2984.895000	20.8	160.5	V	238.0	-22.9	33.2	54.0
4511.145000	23.4	125.7	H	71.0	-19.5	30.6	54.0
6704.345000	26.4	189.4	V	160.0	-14.9	27.6	54.0
7372.625000	28.2	350.0	H	150.0	-13.2	25.8	54.0
7985.660000	28.9	248.4	H	128.0	-12.4	25.1	54.0



LTE BAND 5 RX Receiving mode

Frequency (MHz)	Peak (dBμV/m)	Antenna Height (cm)	POL. (H/V)	Azimuth (deg)	Corr. (dB)	Margin (dB)	Limit (dBμV/m)
3335.210000	33.6	248.5	V	246.0	-22.4	40.4	74.0
5590.055000	36.4	249.9	V	20.0	-17.7	37.6	74.0
7449.725000	41.3	249.4	H	106.0	-12.9	32.7	74.0
9962.975000	44.0	139.6	V	84.0	-9.4	30.0	74.0
11043.475000	45.1	350.0	V	161.0	-5.5	28.9	74.0
14438.365000	46.6	249.9	V	278.0	-1.8	27.4	74.0

Frequency (MHz)	CAverage (dBμV/m)	Antenna Height (cm)	POL. (H/V)	Azimuth (deg)	Corr. (dB)	Margin (dB)	Limit (dBμV/m)
3335.210000	20.8	248.5	V	246.0	-22.4	33.2	54.0
5590.055000	23.8	249.9	V	20.0	-17.7	30.2	54.0
7449.725000	28.2	249.4	H	106.0	-12.9	25.8	54.0
9962.975000	30.8	139.6	V	84.0	-9.4	23.2	54.0
11043.475000	32.4	350.0	V	161.0	-5.5	21.6	54.0
14438.365000	33.9	249.9	V	278.0	-1.8	20.1	54.0

LTE BAND 12 RX Receiving mode

Frequency (MHz)	Peak (dBμV/m)	Antenna Height (cm)	POL. (H/V)	Azimuth (deg)	Corr. (dB)	Margin (dB)	Limit (dBμV/m)
3559.690000	34.7	261.4	V	91.0	-22.1	39.3	74.0
5541.530000	36.3	150.0	V	106.0	-17.8	37.7	74.0
7423.180000	41.3	99.9	H	337.0	-13.0	32.7	74.0
9852.110000	43.9	150.0	V	279.0	-9.5	30.1	74.0
11540.410000	45.4	111.4	V	264.0	-4.8	28.6	74.0
15075.230000	47.4	150.0	H	156.0	-1.5	26.6	74.0

Frequency (MHz)	CAverage (dBμV/m)	Antenna Height (cm)	POL. (H/V)	Azimuth (deg)	Corr. (dB)	Margin (dB)	Limit (dBμV/m)
3559.690000	21.2	261.4	V	91.0	-22.1	32.8	54.0
5541.530000	23.6	150.0	V	106.0	-17.8	30.4	54.0
7423.180000	28.6	99.9	H	337.0	-13.0	25.4	54.0
9852.110000	30.8	150.0	V	279.0	-9.5	23.2	54.0
11540.410000	32.4	111.4	V	264.0	-4.8	21.6	54.0
15075.230000	34.4	150.0	H	156.0	-1.5	19.6	54.0



LTE BAND 25 RX Receiving mode

Frequency (MHz)	Peak (dB μ V/m)	Antenna Height (cm)	POL. (H/V)	Azimuth (deg)	Corr. (dB)	Margin (dB)	Limit (dB μ V/m)
4066.745000	35.9	175.6	V	273.0	-20.7	38.1	74.0
5809.175000	36.7	160.6	V	52.0	-17.4	37.3	74.0
7453.090000	41.3	99.9	H	262.0	-12.8	32.7	74.0
9542.855000	45.0	99.9	V	20.0	-10.0	29.0	74.0
11139.785000	46.2	99.7	H	78.0	-5.4	27.8	74.0
14718.755000	47.4	350.0	H	327.0	-1.4	26.6	74.0

Frequency (MHz)	CAverage (dB μ V/m)	Antenna Height (cm)	POL. (H/V)	Azimuth (deg)	Corr. (dB)	Margin (dB)	Limit (dB μ V/m)
4066.745000	22.9	175.6	V	273.0	-20.7	31.1	54.0
5809.175000	24.3	160.6	V	52.0	-17.4	29.7	54.0
7453.090000	28.4	99.9	H	262.0	-12.8	25.6	54.0
9542.855000	31.6	99.9	V	20.0	-10.0	22.4	54.0
11139.785000	32.3	99.7	H	78.0	-5.4	21.7	54.0
14718.755000	34.1	350.0	H	327.0	-1.4	19.9	54.0

LTE BAND 41 RX Receiving mode

Frequency (MHz)	Peak (dB μ V/m)	Antenna Height (cm)	POL. (H/V)	Azimuth (deg)	Corr. (dB)	Margin (dB)	Limit (dB μ V/m)
1326.465000	29.6	219.4	V	232.0	-28.5	44.4	74.0
3435.940000	33.5	138.6	V	345.0	-22.3	40.5	74.0
5677.360000	35.9	99.8	V	281.0	-17.6	38.1	74.0
7524.740000	41.4	99.7	V	0.0	-12.6	32.6	74.0
11291.935000	46.5	99.9	V	153.0	-5.1	27.5	74.0
14760.725000	46.8	175.5	H	61.0	-1.4	27.2	74.0

Frequency (MHz)	CAverage (dB μ V/m)	Antenna Height (cm)	POL. (H/V)	Azimuth (deg)	Corr. (dB)	Margin (dB)	Limit (dB μ V/m)
1326.465000	17.4	219.4	V	232.0	-28.5	36.6	54.0
3435.940000	20.9	138.6	V	345.0	-22.3	33.1	54.0
5677.360000	23.7	99.8	V	281.0	-17.6	30.3	54.0
7524.740000	28.6	99.7	V	0.0	-12.6	25.4	54.0
11291.935000	33.1	99.9	V	153.0	-5.1	20.9	54.0
14760.725000	34.2	175.5	H	61.0	-1.4	19.8	54.0



6. CONCLUSION

The data collected shows that the **EUT Type: VoLTE+CDMA Home Phone Connect, Model: T720** complies with §15.107 and §15.109 of the FCC rules.



7. APPENDIX A. TEST SETUP PHOTOGRAPHS

Please refer to Appendix A