

RG2102

Antenna Specifications

► Contents ◀

1 Electronic Specification

1.1 Top Antenna

1.1.1 VSWR & Gain

1.2 BTM Antenna

1.2.1 VSWR & Gain

2 Test Condition

2.1 Test Environment (Condition/Method)

3 Antenna Description

3.1 Type

3.2 Model number

4 List of Measuring Equipment

5 Manufacturer

1 Electronic Specification

1.1 Top Antenna

1.1.1 VSWR & Gain

① DRX Passive Data (ANT2)

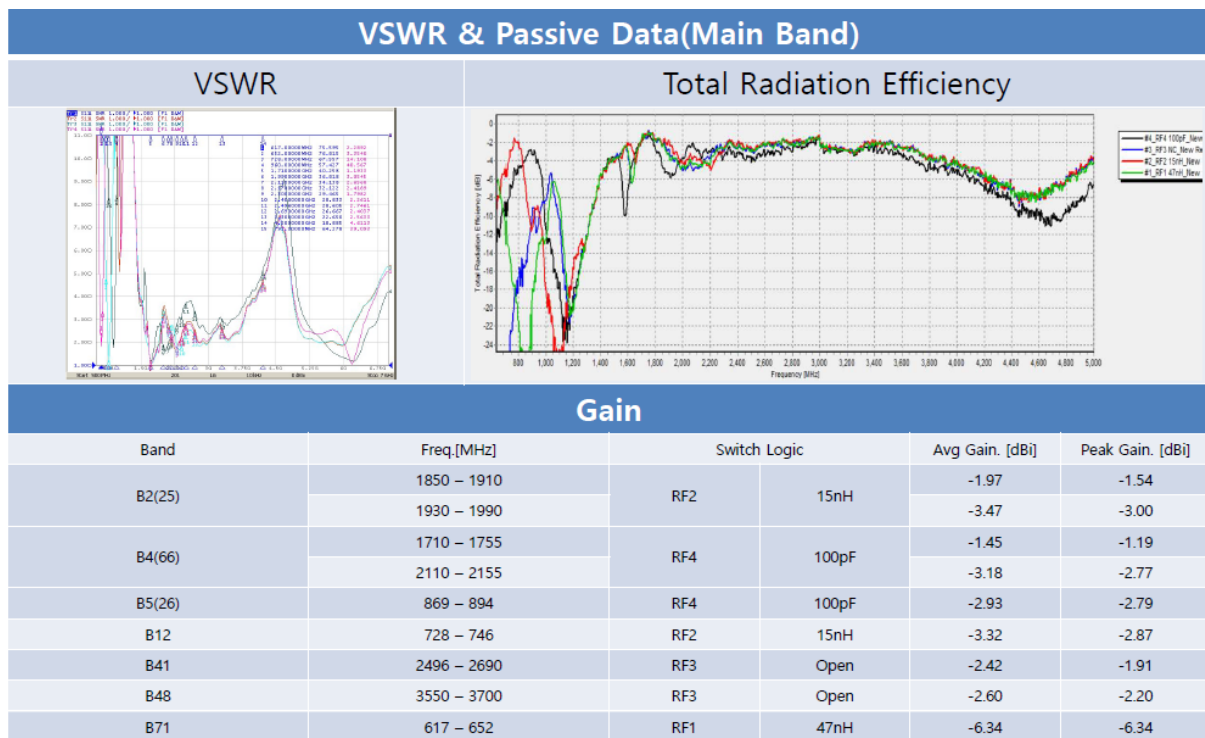

		Radiation Pattern		
		XY	XZ	YZ
DRX(ANT2)	B2 (25)			
	B4 (66)			
	B5 (26)			
	B12			
	B41			
	B48			
	B71			

② MIMO DRX, PRX Passive Data (ANT3)

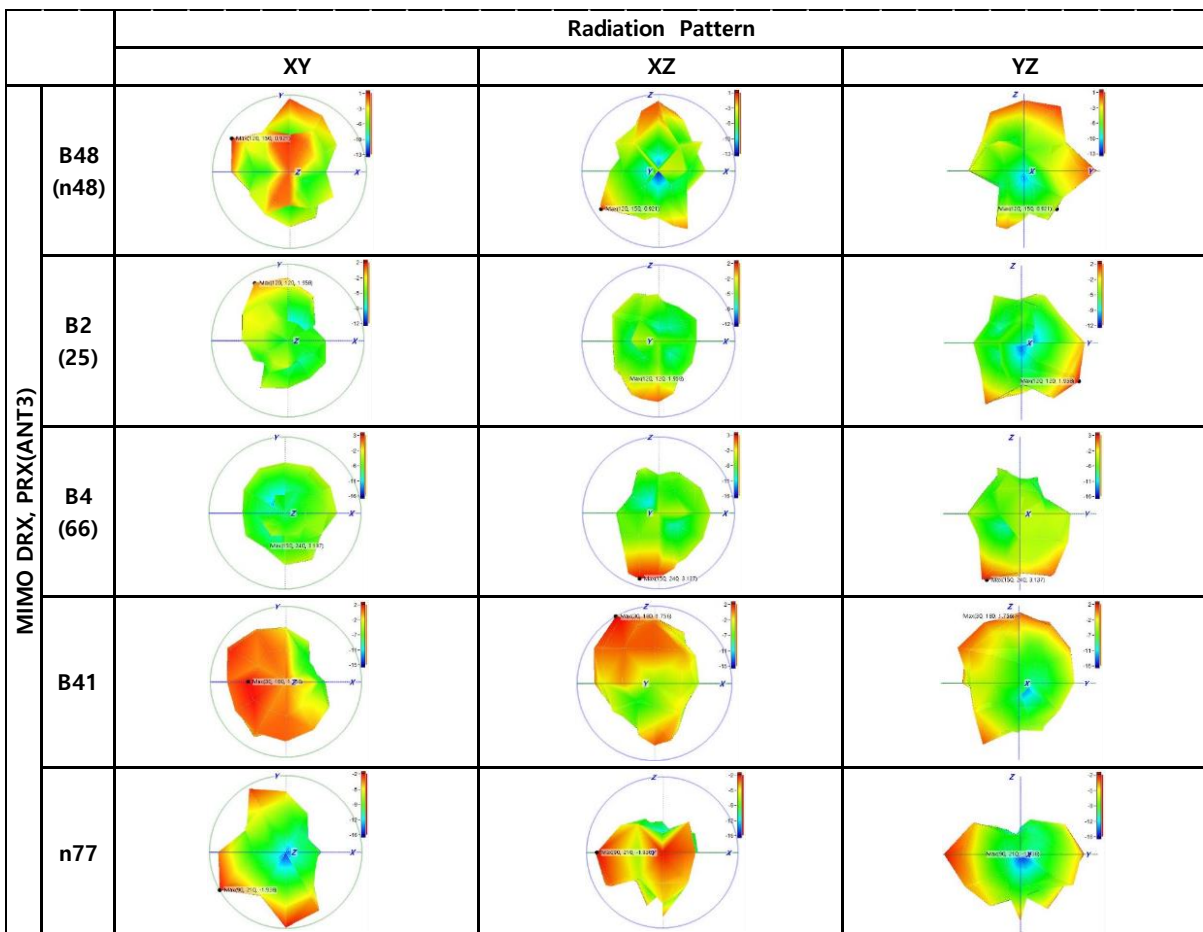
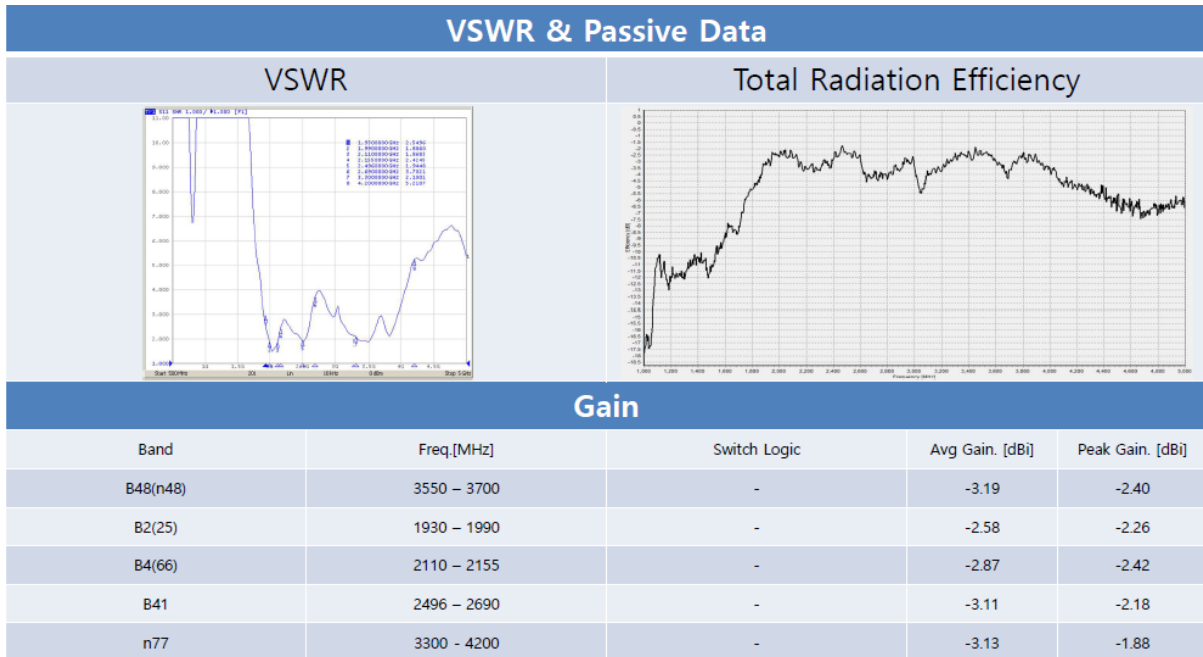

③ WIFI0 Passive Data (ANT6)

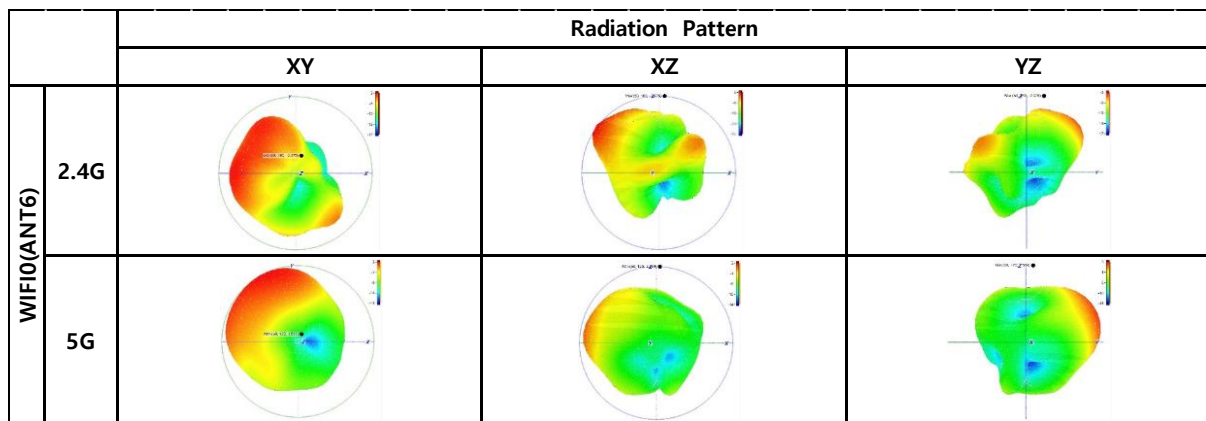
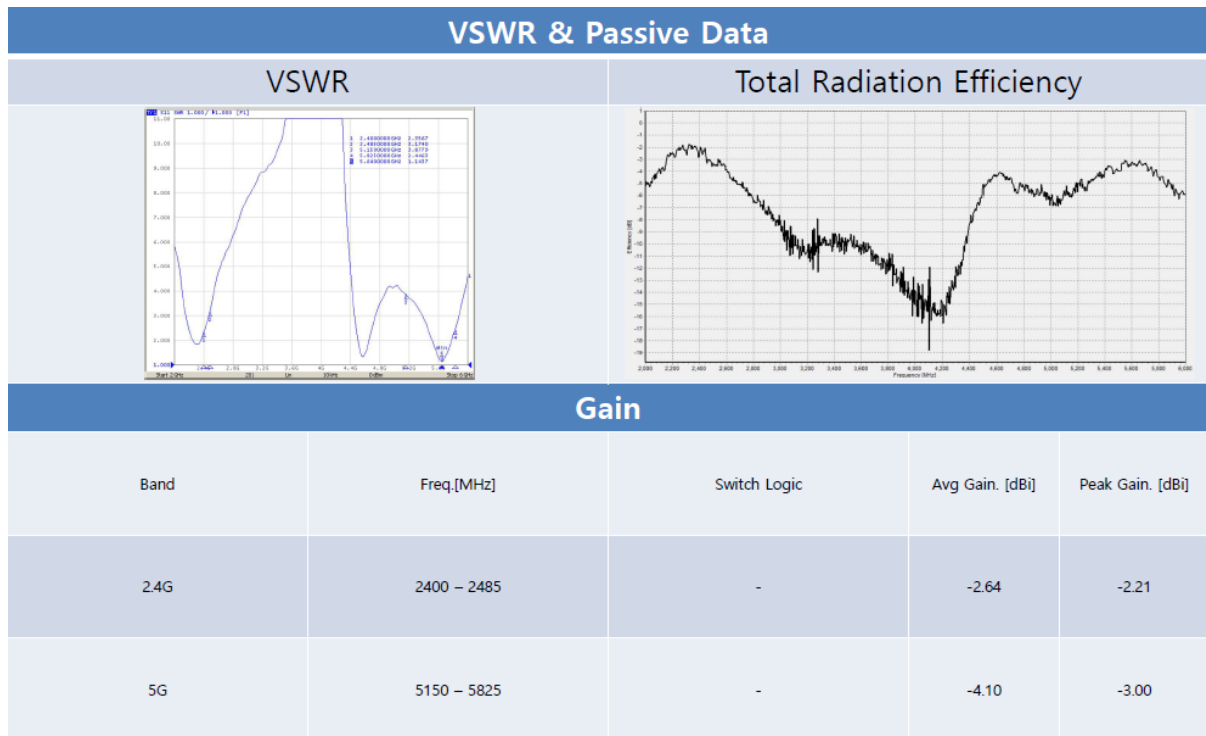

1.2 BTM Antenna

1.2.1 VSWR & Gain

① Main Passive Data (ANT0)

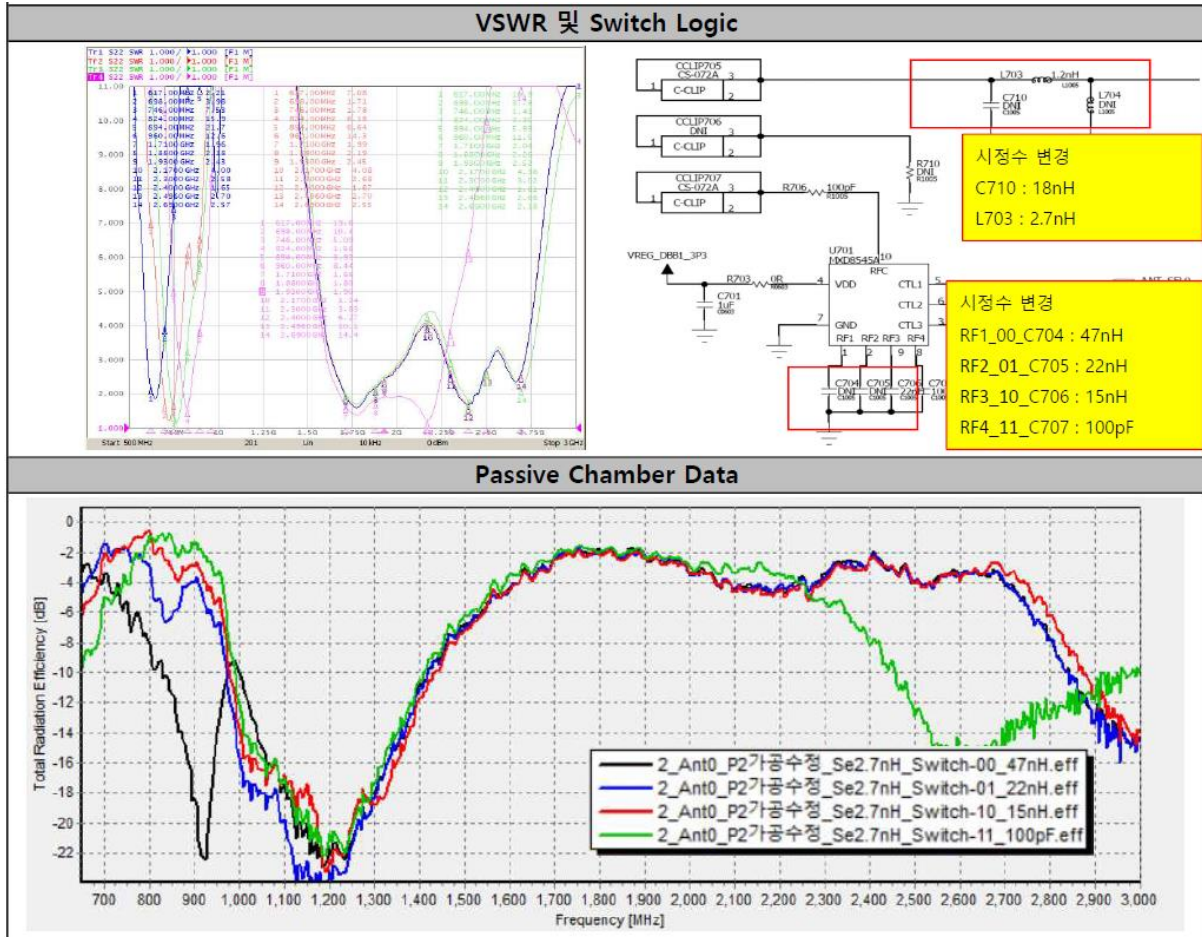

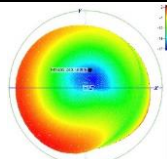
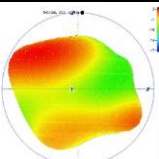
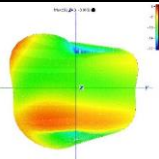
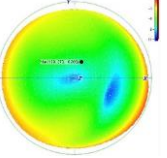
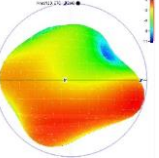
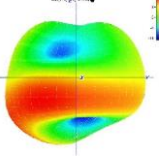
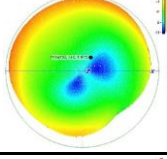
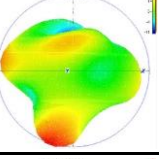
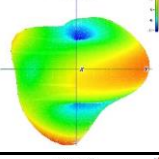
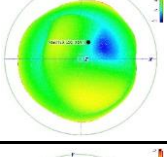
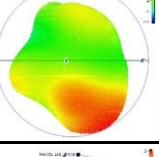
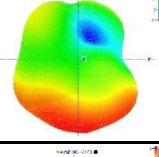
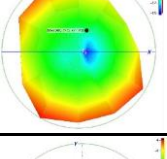
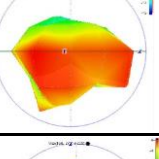
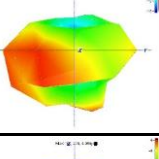
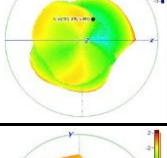
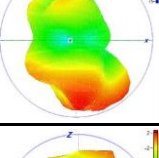
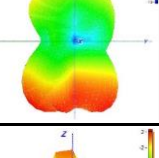
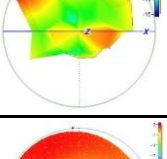
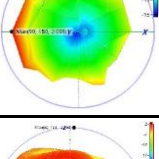
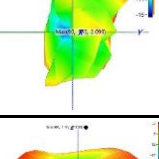
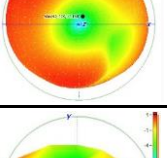
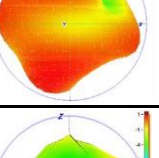
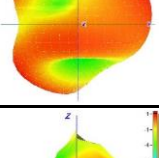
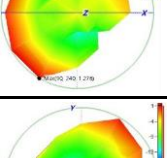
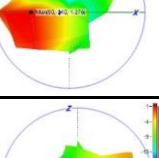
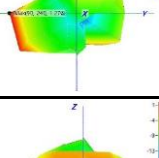
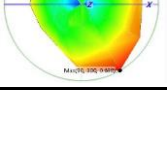
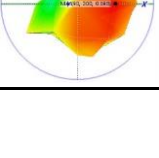
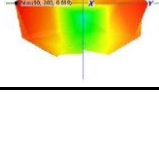
		Radiation Pattern		
		XY	XZ	YZ
Main(ANT0)	B71			
	B12			
	B5 (26)			
	B4 (66)			
	B2 (25)			
	B41			
	B29			
	B14			
	B20			
	B8			

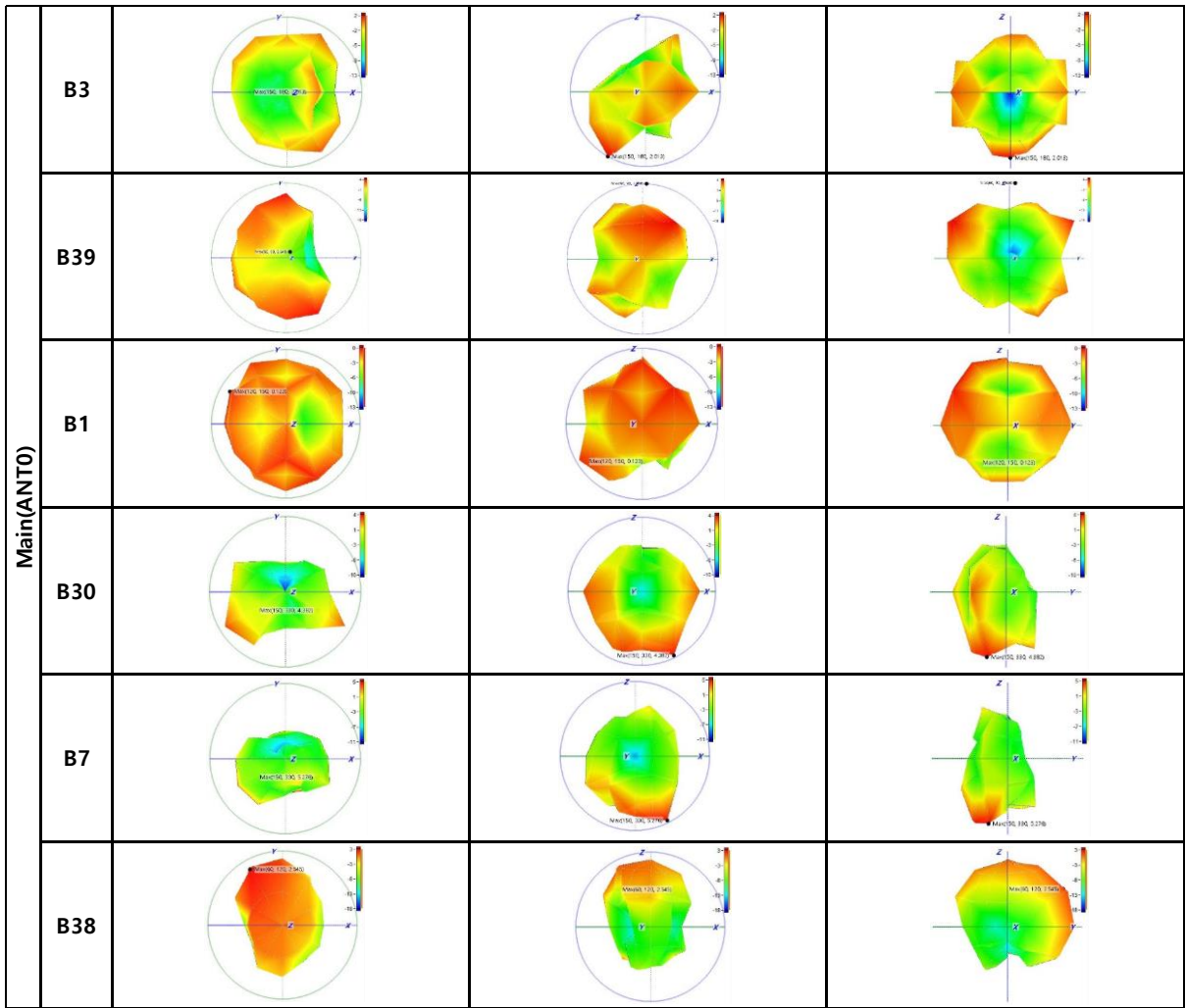

② MIMO PRX Passive Data (ANT1)

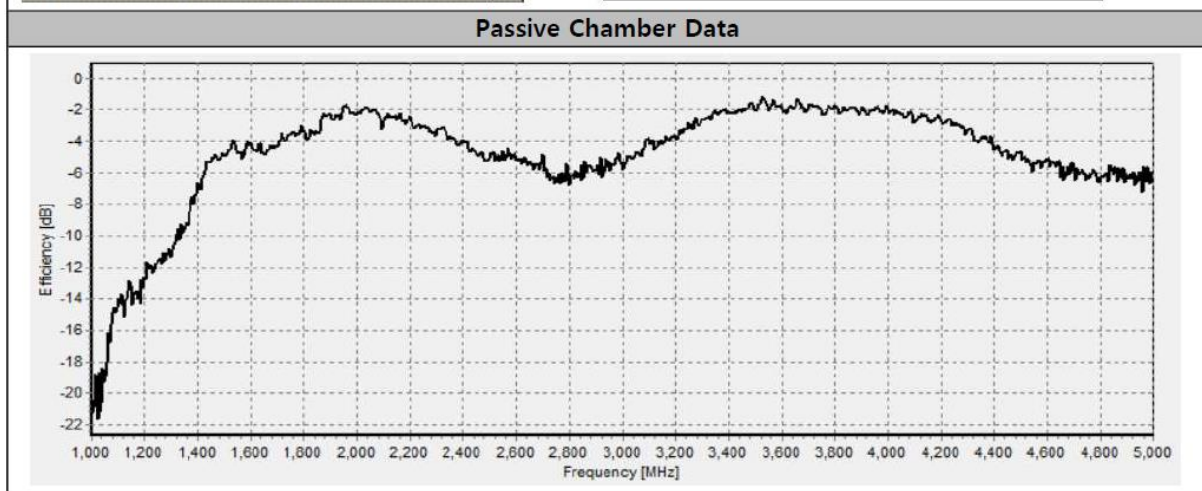
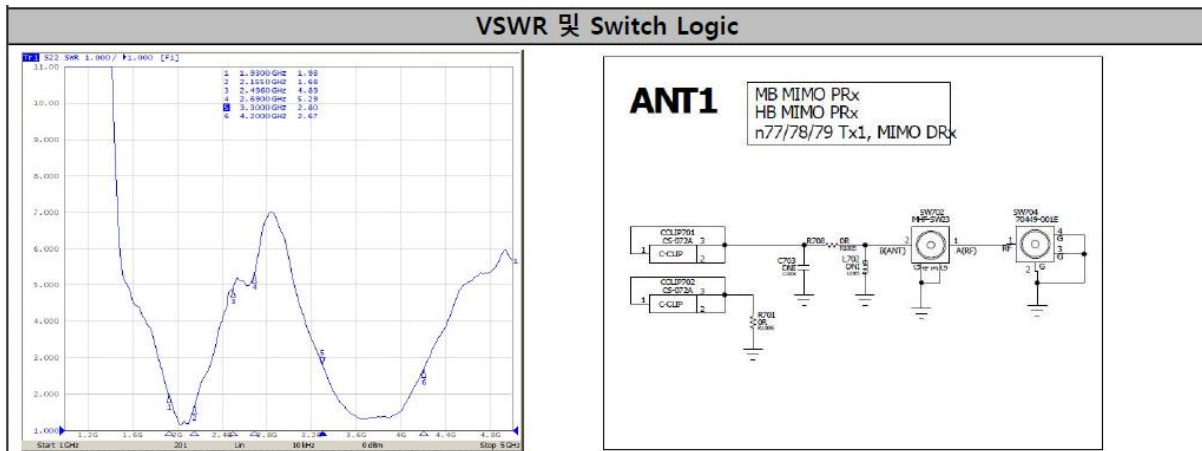

Passive Chamber Data (Gain)

BAND	Freq.[MHz]	Switch Logic	Gain [dB]		BAND	Freq.[MHz]	Switch Logic	Gain [dB]	
			AVG.	Peak				AVG.	Peak
B2(25)	1930-1990	-	-2.11	-1.72	B48	3550-3700	-	-1.79	-1.32
B4(66)	2110-2155		-2.45	-2.24	n77	3300-4200		-2.03	-1.12
B41	2496-2690		-5.12	-4.41					

		Radiation Pattern		
		XY	XZ	YZ
MIMO PRX(ANT1)	B2 (25)			
	B4 (66)			
	B41			
	B48			
	n77			

③ UHB TRX0 Passive Data (ANT4)

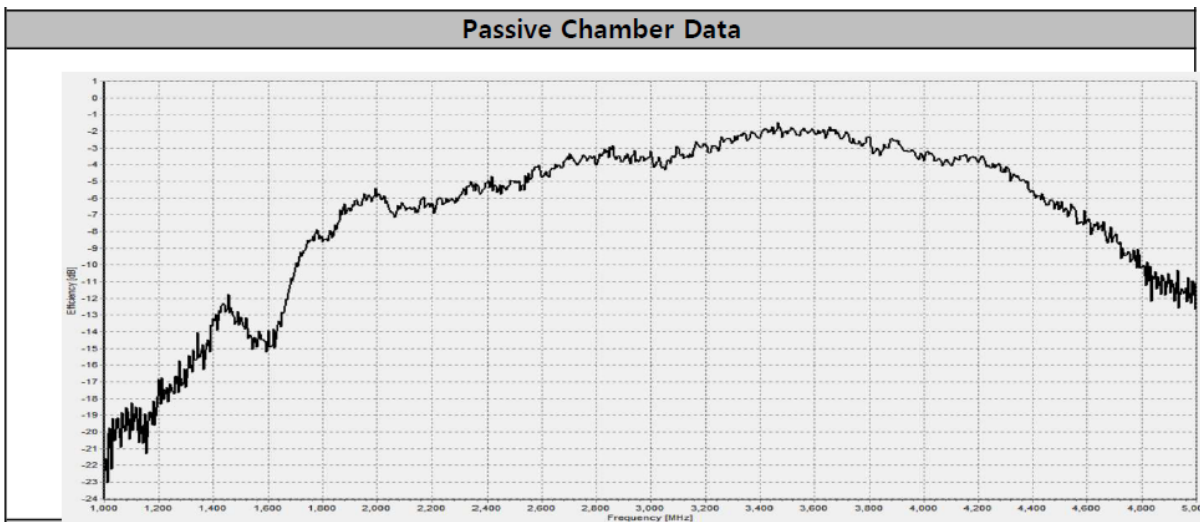
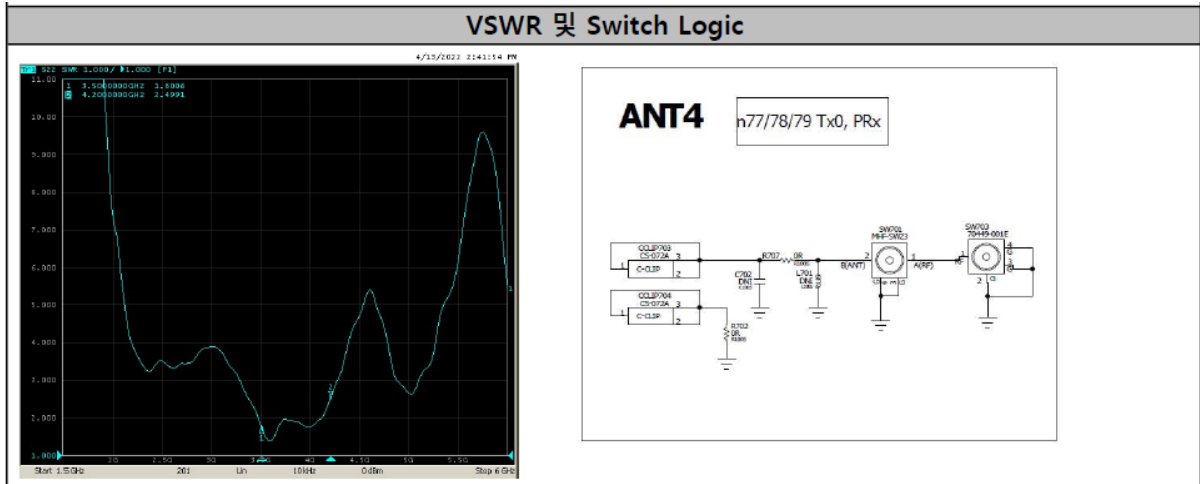

Passive Chamber Data (Gain)

BAND	Freq.[MHz]	Switch Logic	Gain [dB]	
			AVG.	Peak
B48 (n48)	3550-3700		-2.04	-1.71
n77	3300-4200		-2.65	-1.49

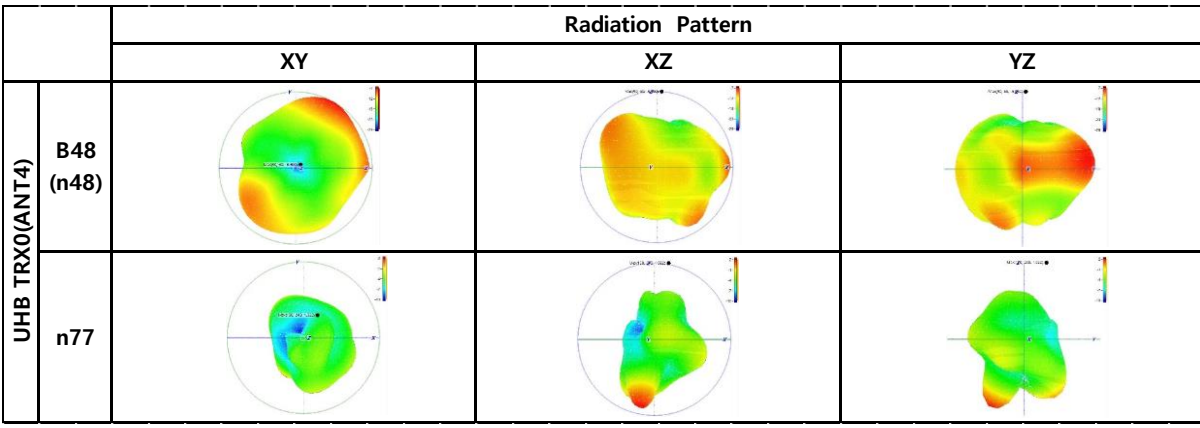

④ WIFI1 Passive Data (ANT7)

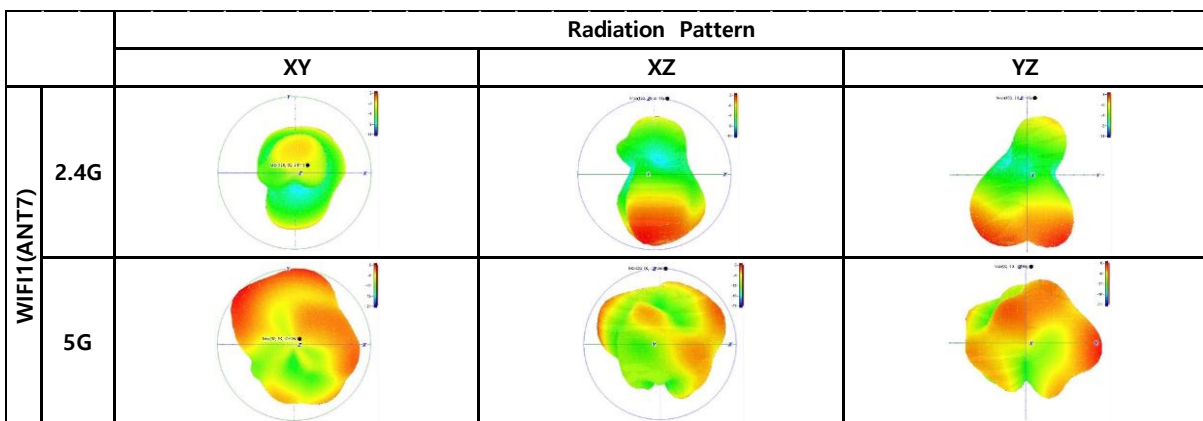
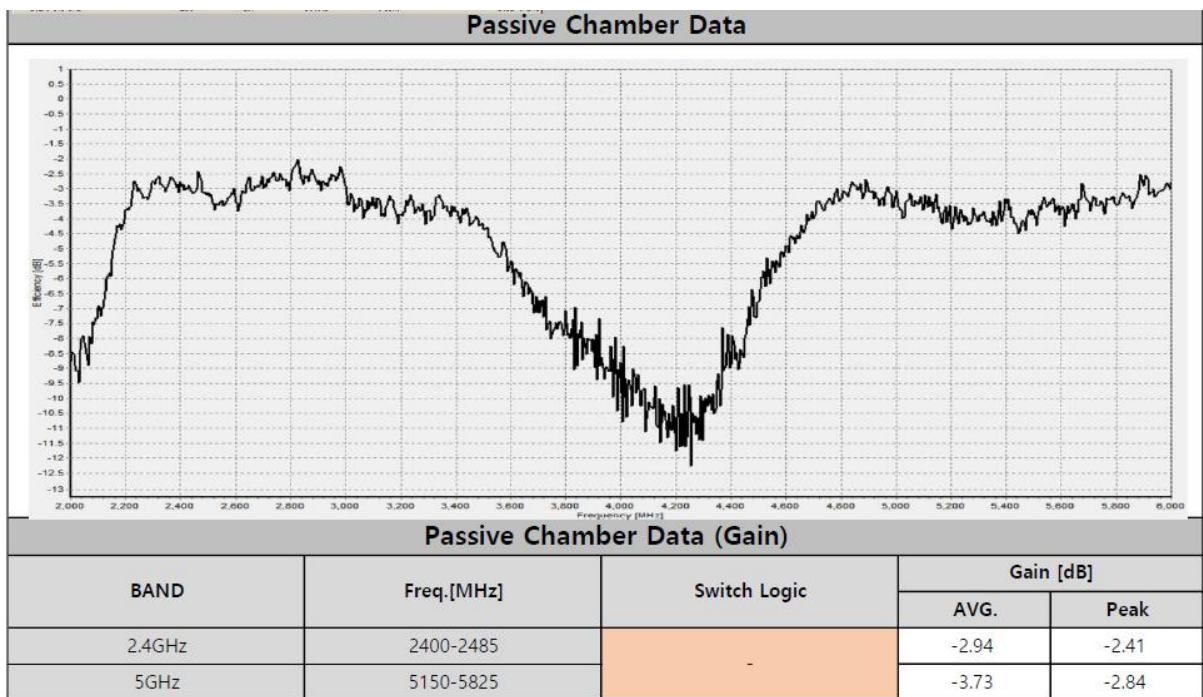
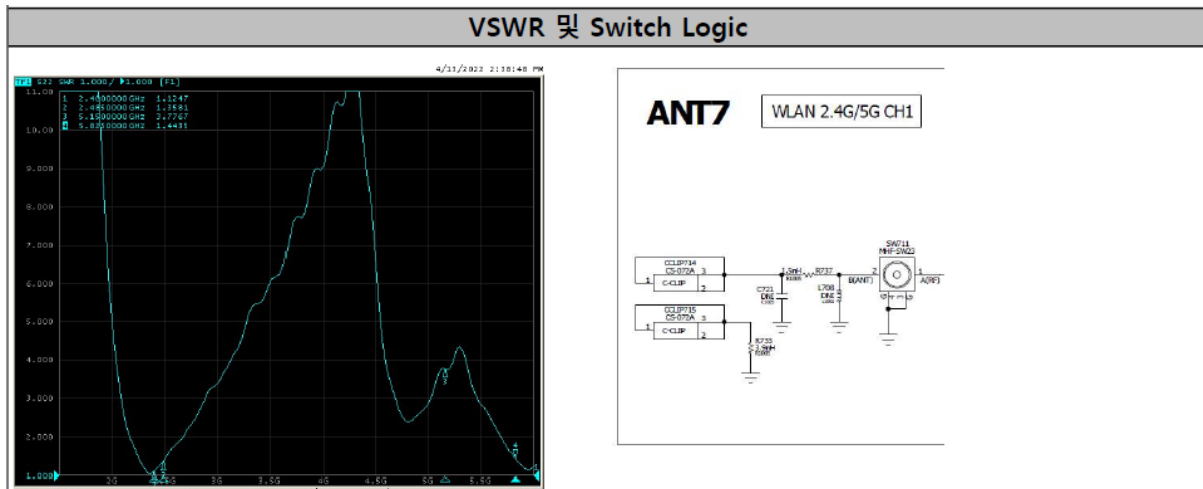

2 Test Condition

2.1 Test Environment (Condition/Method)

① Voltage Standing Wave Ratio(VSWR)

Step 1. Set the frequency range after connect 50cm cable to Network analyzer.

Step 2. Connect Calibration Kit to Network analyzer and calibrate.

Step 3. Fix the cable and keep separation distance over 30cm for reducing effect by Network analyzer.

Step 4. Fix insulator over 5cm on the bottom of measuring antenna.

Step 5. Measure VSWR with setting marker of desired frequency.

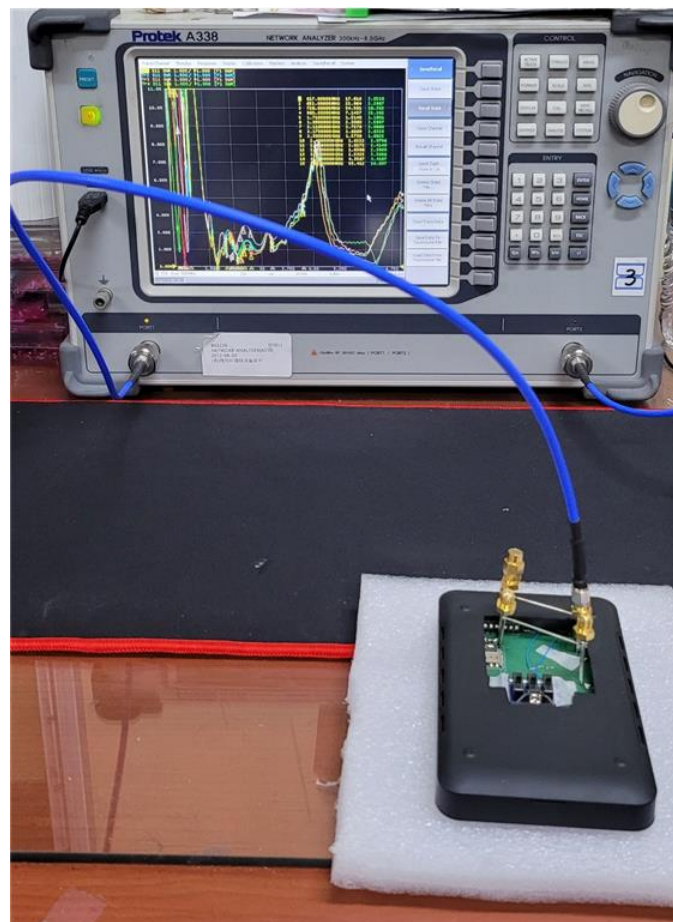

② Radiation & Gain

Step 1. Calibrate the Chamber system using Horn antenna, and set up the software to control the Chamber system at the same time.

Step 2. Keep the measuring antenna to holder.

Step 3. Measure Gain & efficiency.

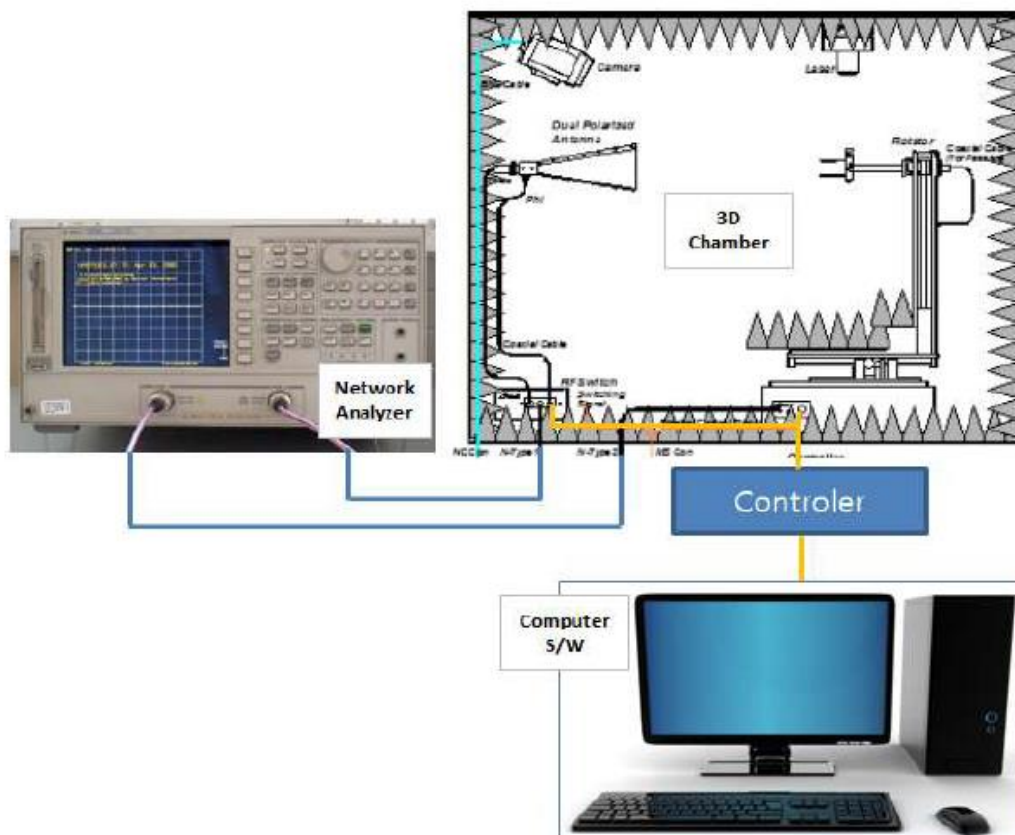

3 Antenna description

3.1 Type : PIFA

3.2 Model number

① Top Antenna : ALDSBRG2102

② BTM Antenna : ALDMARG2102

4 List of Measuring Equipment

Instrument	Manufacturer	Model No.	Serial No.	Characteristics	Calibration Date	Due Date	Remark
Network Analyzer	Protek	A338	GSI_12090007	300kHz - 8G	Aug. 04. 2022	Aug. 04. 2023	VSWR
Network Analyzer	Agilent Technologies	ENA E5071B	MY42100528	300kHz - 8.5G	May. 02. 2022	May. 02. 2023	Radiation Gain

5 Manufacturer

Test Site	Vendor	Address
Korea	Patron	22, Samsung 1-ro 2-gil, Seokwoo-dong, Hwaseong-si, Gyeonggi-do

Model Name	RG2102_Top	업체명	파트론	Part Number	ALDSBRG2102
Revision	1.0			개정 일자	2022-08-05

2. 제품 사양

2.1.1 치수도면_기구

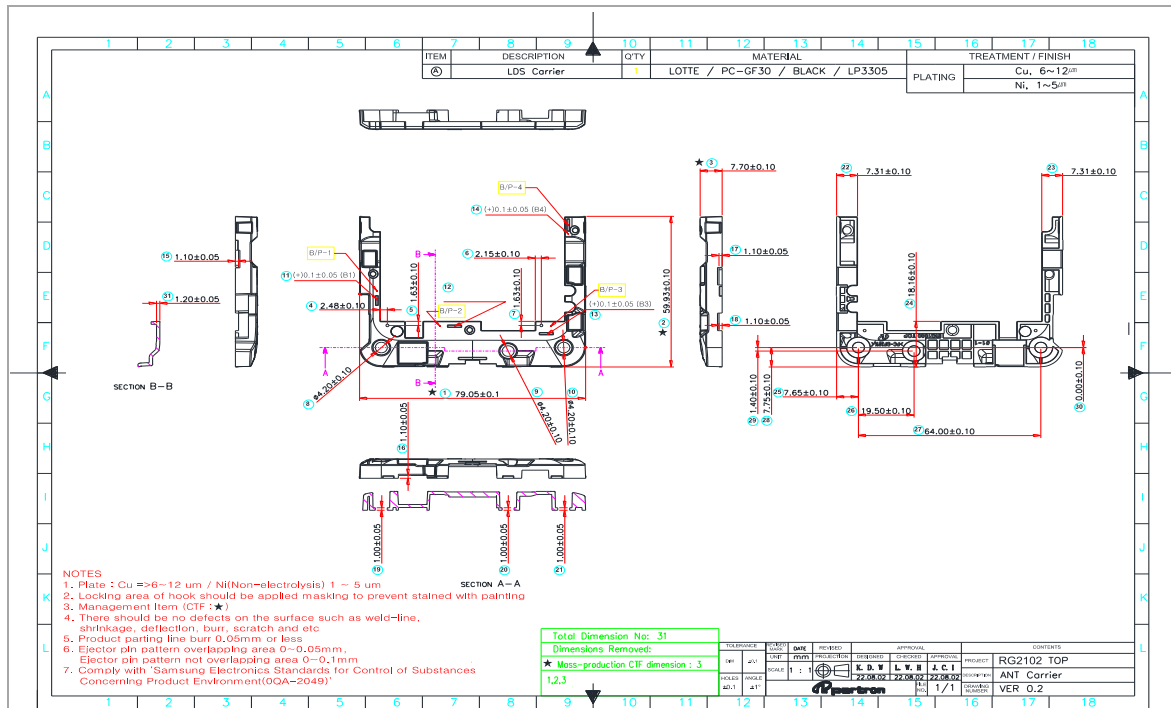

Model Name	RG2102_Top	업체명	파트론	Part Number	ALDSBRG2102
Revision	1.0			개정 일자	2022-08-05

2. 제품 사양

2.1.2 치수도면_Pattern

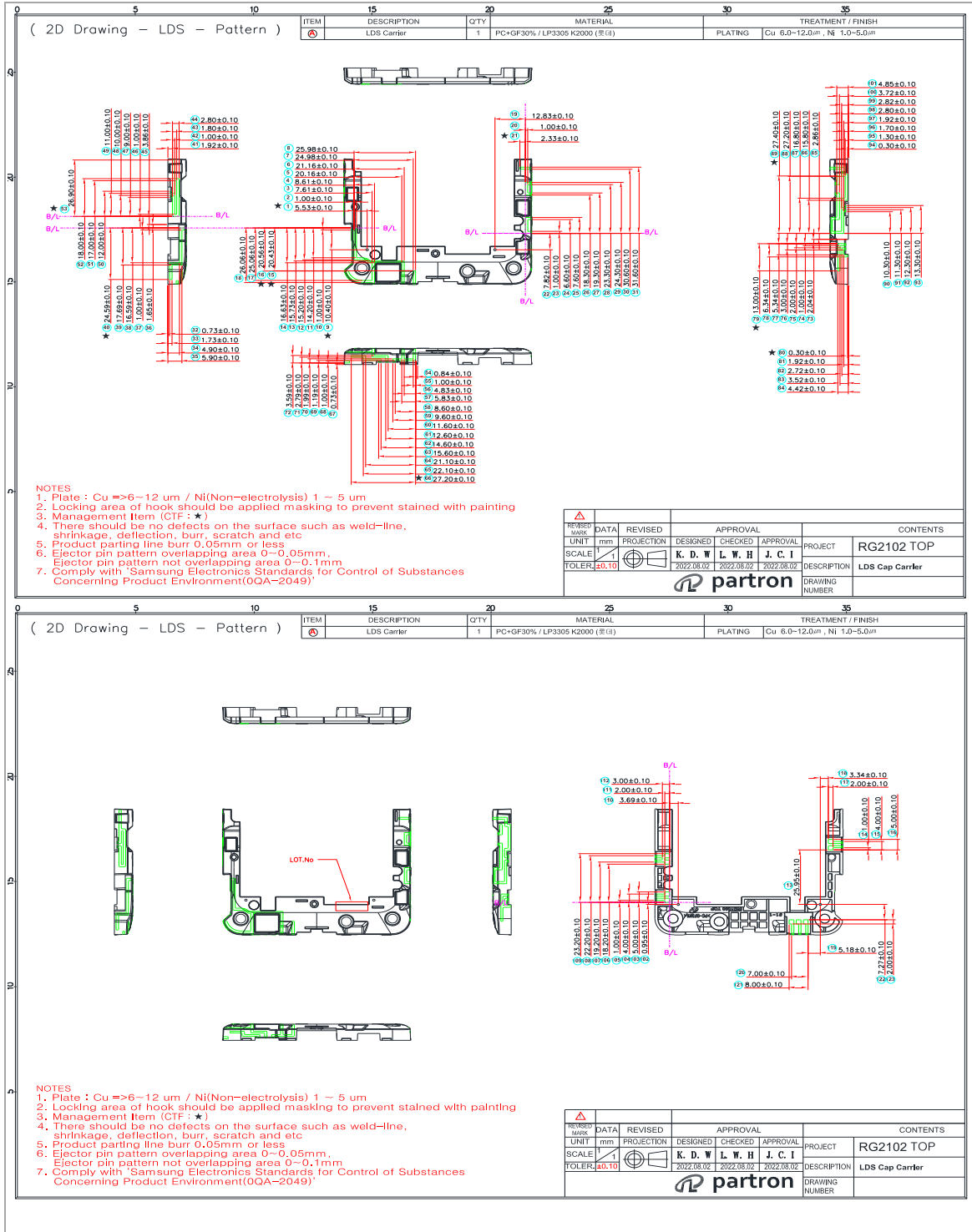

Model Name	RG2102_BTM	업체명	파트론	Part Number	ALDMARG2102
Revision	1.0			개정 일자	2022-08-05

2. 제품 사양

2.1.1 치수도면_기구

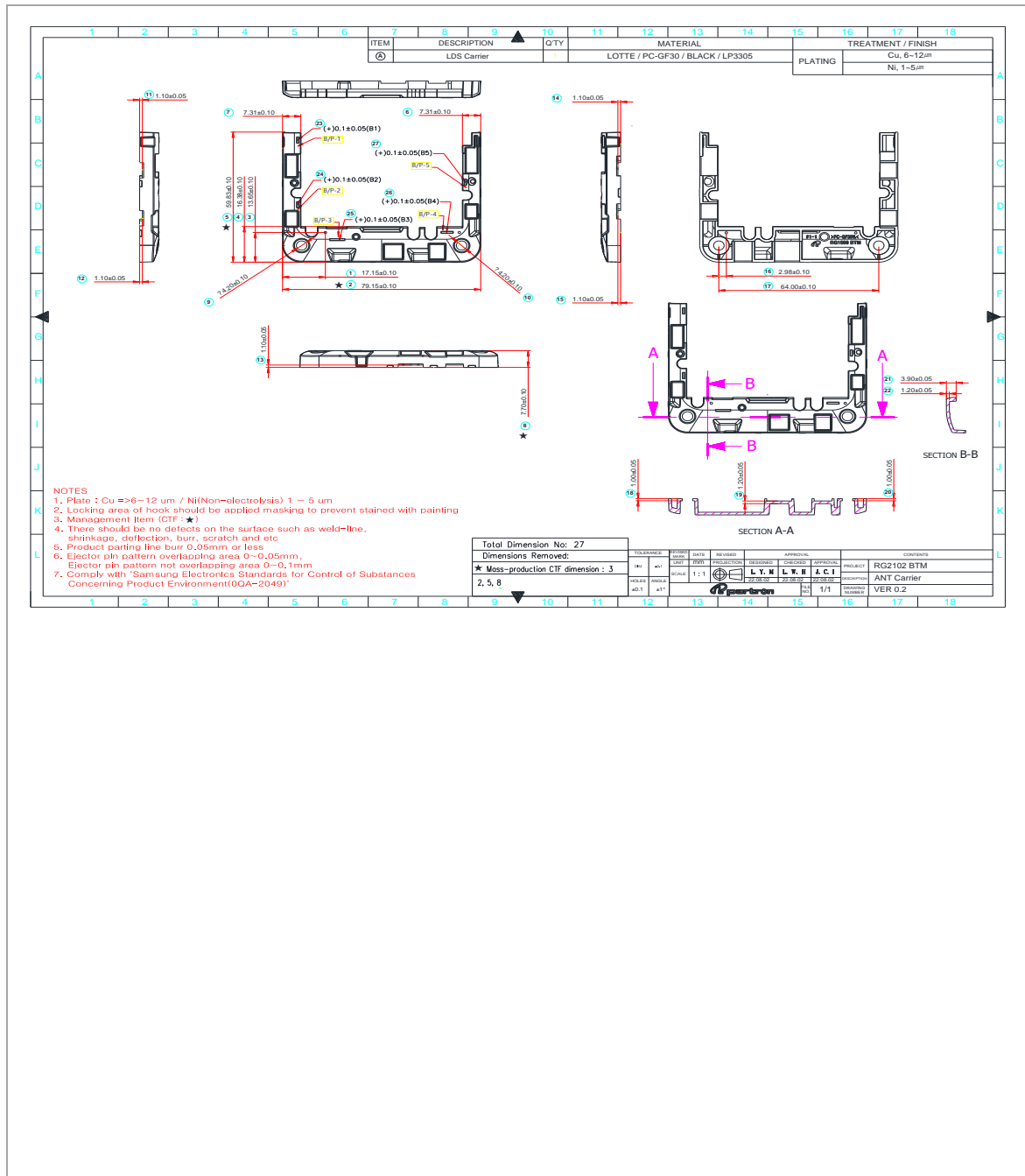

Model Name	RG2102_BTM	업체명	파트론	Part Number	ALDMARG2102
Revision	1.0			개정 일자	2022-08-05

2. 제품 사양

2.1.2 치수도면_Pattern

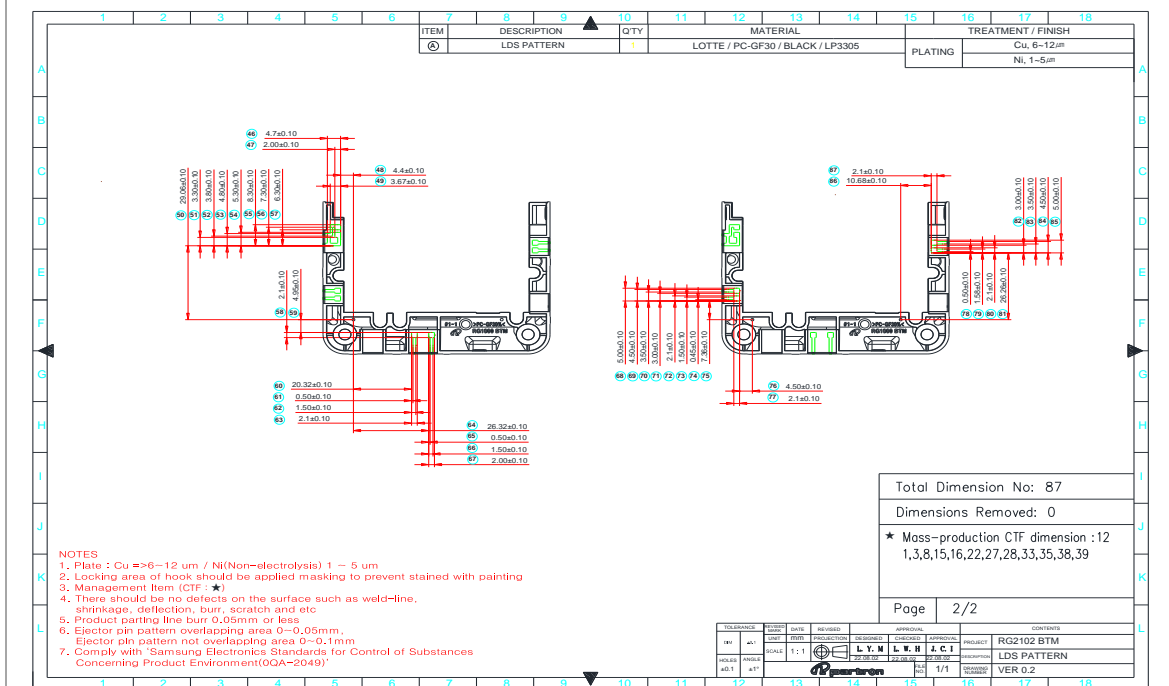
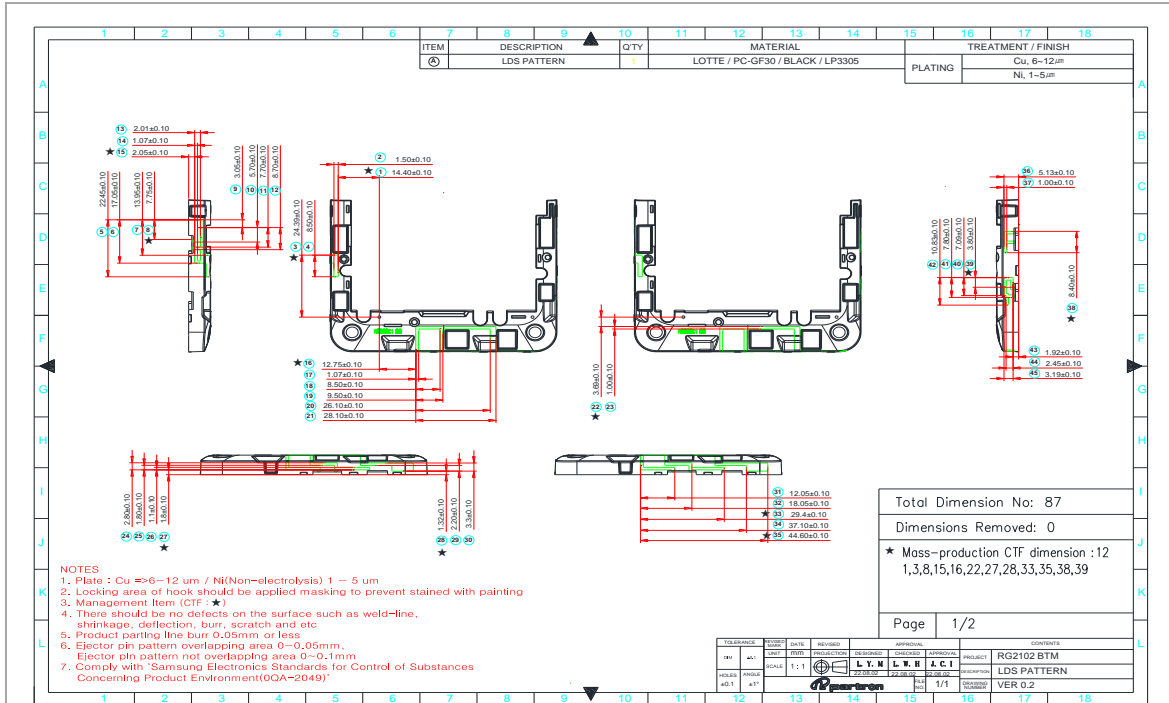

Antenna Trace Layout

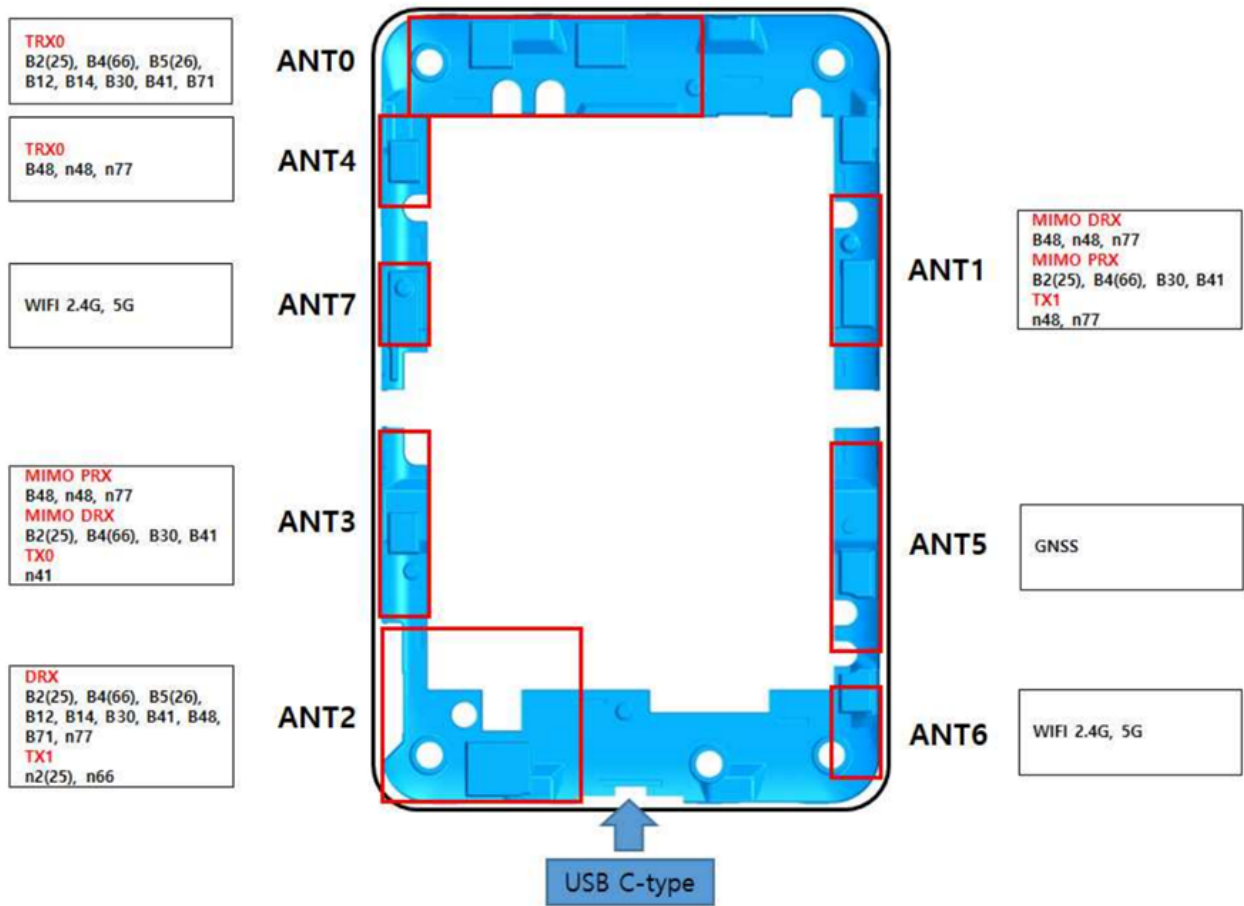

*ANT5 GNSS is not supported in RG2102