



FCC RF Test Report

APPLICANT : Franklin Technology Inc.
EQUIPMENT : 5G RF module
MODEL NAME : M2500
FCC ID : XHG-M2500
STANDARD : 47 CFR Part 2, Part 27 Subpart Q
CLASSIFICATION : PCS Licensed Transmitter (PCB)
TEST DATE(S) : Jul. 13, 2021 ~ Jul. 28, 2021

We, Sporton International Inc. (Kunshan), would like to declare that the tested sample has been evaluated in accordance with the procedures given in ANSI C63.26-2015 and shown compliance with the applicable technical standards.

This report contains data that were produced under subcontract by Sporton International Inc. (ShenZhen).

The test results in this report apply exclusively to the tested model / sample. Without written approval of Sporton International Inc. (Kunshan), the test report shall not be reproduced except in full.

Jason Jia

Approved by: Jason Jia



Sporton International Inc. (Kunshan)

**No. 1098, Pengxi North Road, Kunshan Economic Development Zone Jiangsu Province 215300
People's Republic of China**



TABLE OF CONTENTS

REVISION HISTORY..... 3
SUMMARY OF TEST RESULT 4
1 GENERAL DESCRIPTION 5
1.1 Applicant 5
1.2 Manufacturer 5
1.3 Product Feature of Equipment Under Test 5
1.4 Product Specification of Equipment Under Test 5
1.5 Modification of EUT 5
1.6 Maximum Conducted Power and Emission Designator 6
1.7 Testing Site 6
1.8 Test Software 7
1.9 Applied Standards 7
2 TEST CONFIGURATION OF EQUIPMENT UNDER TEST 8
2.1 Test Mode 8
2.2 Connection Diagram of Test System 9
2.3 Support Unit used in test configuration and system 9
2.4 Measurement Results Explanation Example 9
2.5 Frequency List of Low/Middle/High Channels 10
3 CONDUCTED TEST ITEMS 11
3.1 Measuring Instruments 11
3.2 Test Setup 11
3.3 Test Result of Conducted Test 11
3.4 Conducted Output Power Measurement 12
3.5 Peak-to-Average Ratio 13
3.6 EIRP 14
3.7 Occupied Bandwidth 15
3.8 Conducted Band Edge Measurement 16
3.9 Conducted Spurious Emission Measurement 17
3.10 Frequency Stability Measurement 18
4 RADIATED TEST ITEMS 19
4.1 Measuring Instruments 19
4.2 Test Setup 19
4.3 Test Result of Radiated Test 20
4.4 Radiated Spurious Emission Measurement 21
5 LIST OF MEASURING EQUIPMENT 22
6 UNCERTAINTY OF EVALUATION 23
APPENDIX A. TEST RESULTS OF CONDUCTED TEST
APPENDIX B. TEST RESULTS OF RADIATED TEST
APPENDIX C. TEST SETUP PHOTOGRAPHS



REVISION HISTORY

REPORT NO.	VERSION	DESCRIPTION	ISSUED DATE
FG262007G	Rev. 01	Initial issue of report	Aug. 23, 2022

SUMMARY OF TEST RESULT

Report Section	FCC Rule	Description	Limit	Result	Remark
3.4	§2.1046	Conducted Output Power	—	Report Only	-
3.5	§27.50 (k)(4)	Peak-to-Average Ratio	<13dB	PASS	
3.6	§27.50 (k)(3)	EIRP	EIRP < 1W (30dBm)	PASS	-
3.7	§2.1049	Occupied Bandwidth	—	Report Only	-
3.8	§2.1051 §27.53 (n)(2)	Conducted Band Edge Measurement	-13dBm/MHz	PASS	-
3.9	§2.1051 §27.53 (n)(2)	Conducted Spurious Emission	-13dBm/MHz	PASS	-
3.10	§2.1055 §27.54	Frequency Stability Temperature & Voltage	Within the band	PASS	-
4.4	§2.1053 §27.53 (n)(2)	Radiated Spurious Emission	-13dBm/MHz	PASS	Under limit 24.24 dB at 10356.000 MHz

Declaration of Conformity:
The test results with all measurement uncertainty excluded are presented in accordance with the regulation limits or requirements declared by manufacturers.
Comments and Explanations:
The declared of product specification for EUT presented in the report are provided by the manufacturer, and the manufacturer takes all the responsibilities for the accuracy of product specification.

1 General Description

1.1 Applicant

Franklin Technology Inc.

906 JEI Platz, 186, Gasan digital 1-ro, Gumcheon-Gu, Seoul, South Korea, 08502

1.2 Manufacturer

Franklin Technology Inc.

906 JEI Platz, 186, Gasan digital 1-ro, Gumcheon-Gu, Seoul, South Korea, 08502

1.3 Product Feature of Equipment Under Test

Product Feature	
Equipment	5G RF module
Model Name	M2500
FCC ID	XHG-M2500
IMEI Code	Conducted: 358563790001254 358563790001247 Radiation: 358563790000926
HW Version	P1
SW Version	RG2100.TM.1354
EUT Stage	Identical Prototype

1.4 Product Specification of Equipment Under Test

Product Feature	
Tx/Rx Frequency	5G NR n77: 3450 MHz ~ 3550 MHz
SCS	30kHz
Bandwidth	10MHz / 15MHz / 20MHz / 30MHz / 40MHz / 50MHz / 60MHz / 70MHz / 80MHz / 90MHz / 100MHz
Maximum Output Power to Antenna	5G NR n77 : 24.63 dBm
Antenna Gain	5G NR n77 : -1.49 dBi
Type of Modulation	CP-OFDM: QPSK / 16QAM / 64QAM / 256QAM DFT-s-OFDM: PI/2 BPSK / QPSK / 16QAM / 64QAM / 256QAM

Remark: 5G NR n77 supports HPUE mode and SA mode only.

1.5 Modification of EUT

No modifications are made to the EUT during all test items.

1.6 Maximum Conducted Power and Emission Designator

5G NR n77		PI/2 BPSK / QPSK		16QAM/64QAM/256QM	
BW (MHz)	Frequency Range (MHz)	Maximum Conducted power (W)	Emission Designator (99%OBW)	Maximum Conducted power (W)	Emission Designator (99%OBW)
10	3455.01 ~ 3544.98	0.2871	8M58G7D	0.2223	8M62W7D
15	3457.50 ~ 3542.49	0.2844	13M6G7D	0.2344	13M6W7D
20	3460.02 ~ 3540.00	0.2871	18M2G7D	0.2355	18M2W7D
30	3465.00 ~ 3534.99	0.2884	27M9G7D	0.2382	27M9W7D
40	3470.01 ~ 3529.98	0.2851	37M9G7D	0.2432	37M9W7D
50	3475.02 ~ 3525.00	0.2897	47M5G7D	0.2360	47M5W7D
60	3480.00 ~ 3519.99	0.2884	57M9G7D	0.2355	57M8W7D
70	3485.01 ~ 3514.98	0.2761	67M6G7D	0.2280	67M5W7D
80	3490.02 ~ 3510.00	0.2685	77M5G7D	0.2228	77M7W7D
90	3495.00 ~ 3504.99	0.2692	87M5G7D	0.2234	87M7W7D
100	3500.01	0.2904	97M5G7D	0.2148	97M5W7D

Note: All modulations have been tested, and only the worst test results of PSK & QAM are shown in the report.

1.7 Testing Site

Sporton International Inc. (Kunshan) is accredited to ISO/IEC 17025:2017 by American Association for Laboratory Accreditation with Certificate Number 5145.02.

Test Firm	Sporton International Inc. (Kunshan)		
Test Site Location	No. 1098, Pengxi North Road, Kunshan Economic Development Zone Jiangsu Province 215300 People's Republic of China TEL : +86-512-57900158 FAX : +86-512-57900958		
Test Site No.	Sporton Site No.	FCC Designation No.	FCC Test Firm Registration No.
	03CH04-KS	CN1257	314309

Sporton International Inc. (Shenzhen) is accredited to ISO/IEC 17025:2017 by American Association for Laboratory Accreditation with Certificate Number 5145.01.

Test Firm	Sporton International (Shenzhen) Inc.		
Test Site Location	1/F, 2/F, Bldg 5, Shiling Industrial Zone, Xinwei Village, Xili, Nanshan, Shenzhen, 518055 People's Republic of China TEL: +86-755-86379589 FAX: +86-755-86379595		
Test Site No.	Sporton Site No.	FCC Designation No.	FCC Test Firm Registration No.
	TH01-SZ	CN1256	421272

Note: Test data subcontracted: conducted test results in section 3 of this report

1.8 Test Software

Item	Site	Manufacturer	Name	Version
1.	03CH04-KS	AUDIX	E3	6.2009-8-24a

1.9 Applied Standards

According to the specifications of the manufacturer, the EUT must comply with the requirements of the following standards:

- 47 CFR Part 2, Part 27 Subpart Q
- ANSI C63.26-2015
- FCC KDB 971168 Power Meas License Digital Systems D01 v03r01
- FCC KDB 412172 D01 Determining ERP and EIRP v01r01
-

Remark: All test items were verified and recorded according to the standards and without any deviation during the test.

2 Test Configuration of Equipment Under Test

2.1 Test Mode

Antenna port conducted and radiated test items listed below are performed according to KDB 971168 D01 Power Meas. License Digital Systems v03r01 with maximum output power.

Radiated measurements are performed by rotating the EUT in three different orthogonal test planes to find the maximum emission.(Z-Plane)

Test Cases	Band	Bandwidth (MHz)	Modulation	RB #	Test Channel
		eg. 5M, 10M, 15M, 20M	eg. QPSK, 16QAM, 64QAM	1RB, Partial RB, Full RB	L/M/H
Max. Output Power	5G n77	10M, 15M, 20M, 30M, 40M, 50M, 60M, 70M, 80M, 90M, 100M	PI/2 BPSK , QPSK, 16QAM, 64QAM, 256 QAM	1RB, Partial RB, Full RB	L, M, H
Peak-to-Average Ratio	5G n77	20M	PI/2 BPSK , QPSK	1RB, Full RB	L, M, H
E.I.R.P	5G n77	10M, 15M, 20M, 30M, 40M, 50M, 60M, 70M, 80M, 90M, 100M	PI/2 BPSK , QPSK, 16QAM, 64QAM, 256 QAM	1RB, Partial RB, Full RB	L, M, H
26dB and 99% Bandwidth	5G n77	10M, 15M, 20M, 30M, 40M, 50M, 60M, 70M, 80M, 90M, 100M	PI/2 BPSK , QPSK, 16QAM, 64QAM, 256 QAM	Full RB	M
Conducted Band Edge	5G n77	10M, 50M, 100M	PI/2 BPSK , QPSK	1RB, Full RB	L, H
Conducted Spurious Emission	5G n77	10M, 50M, 100M	PI/2 BPSK , QPSK	1RB	L, M, H
Frequency Stability	5G n77	20M	QPSK	Full RB	M
Radiated Spurious Emission	5G n77	Worst case			M

Note:

- The device is investigated from 30MHz to 10 times of fundamental signal for radiated spurious emission test under different RB size/offset and modulations in exploratory test. Subsequently, only the worst case emissions are reported.
- Normal Voltage = 3.8Vdc ; Low Voltage =3.6Vdc.; High Voltage =4.2Vdc

2.2 Connection Diagram of Test System

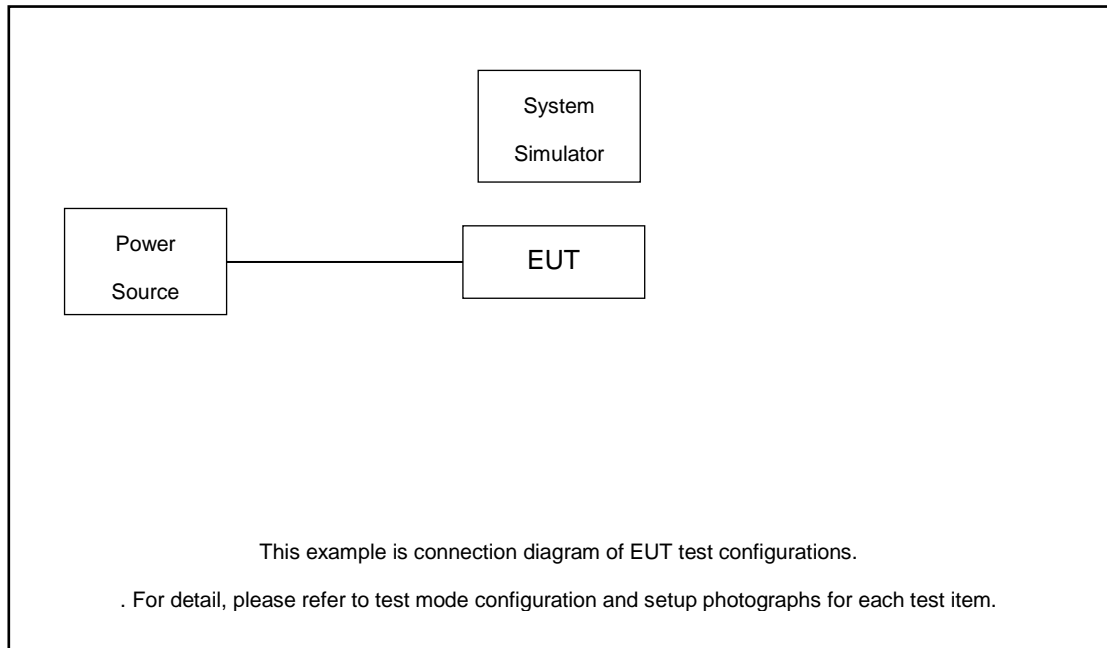

2.3 Support Unit used in test configuration and system

Item	Equipment	Trade Name	Model No.	FCC ID	Data Cable	Power Cord
1.	Power Supply	GWINSTEK	PSS-2002	N/A	N/A	Unshielded, 1.8 m
2.	LTE Base Station	Anritsu	MT8820C	N/A	N/A	Unshielded, 1.8 m
3.	NR Base Station	Anritsu	MT8000A	N/A	N/A	Unshielded, 1.8 m
4.	Adapter	N/A	N/A	N/A	N/A	N/A
5.	Test Jig	N/A	N/A	N/A	N/A	N/A

2.4 Measurement Results Explanation Example

For all conducted test items:

The offset level is set in the spectrum analyzer to compensate the RF cable loss and attenuator factor between EUT conducted output port and spectrum analyzer. With the offset compensation, the spectrum analyzer reading level is exactly the EUT RF output level.

The spectrum analyzer offset is derived from RF cable loss.

Offset = RF cable loss.

Following shows an offset computation example with cable loss 8.6 dB.

Example :

$$\begin{aligned} \text{Offset(dB)} &= \text{RF cable loss(dB)} \\ &= 8.6 \text{ (dB)} \end{aligned}$$

2.5 Frequency List of Low/Middle/High Channels

5G n77 Channel and Frequency List				
BW [MHz]	Channel/Frequency(MHz)	Lowest	Middle	Highest
100	Channel	-	633334	-
	Frequency	-	3500.01	-
90	Channel	633000	633334	633666
	Frequency	3495	3500.01	3504.99
80	Channel	632668	633334	634000
	Frequency	3490.02	3500.01	3510
70	Channel	632334	633334	634332
	Frequency	3485.01	3500.01	3514.98
60	Channel	632000	633334	634666
	Frequency	3480	3500.01	3519.99
50	Channel	631668	633334	635000
	Frequency	3475.02	3500.01	3525
40	Channel	631334	633334	635332
	Frequency	3470.01	3500.01	3529.98
30	Channel	631000	633334	635666
	Frequency	3465	3500.01	3534.99
20	Channel	630668	633334	636000
	Frequency	3460.02	3500.01	3540
15	Channel	630500	633334	636166
	Frequency	3457.5	3500.01	3542.49
10	Channel	630334	633334	636332
	Frequency	3455.01	3500.01	3544.98

3 Conducted Test Items

3.1 Measuring Instruments

See list of measuring instruments of this test report.

3.2 Test Setup

3.2.1 Conducted Output Power



3.2.2 Peak-to-Average Ratio, Occupied / 26dB Bandwidth ,Band-Edge and Conducted Spurious Emission

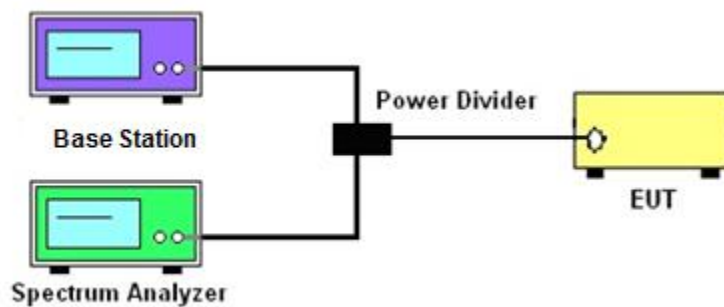

3.2.3 Frequency Stability

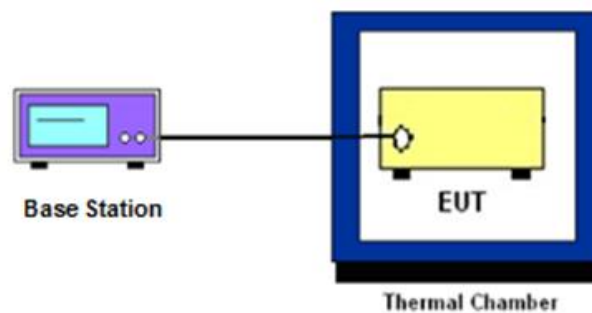

3.3 Test Result of Conducted Test

Please refer to Appendix A.



3.4 Conducted Output Power Measurement

3.4.1 Description of the Conducted Output Power Measurement

A base station simulator was used to establish communication with the EUT. Its parameters were set to transmit the maximum power on the EUT. The measured power in the radio frequency on the transmitter output terminals shall be reported.

3.4.2 Test Procedures

1. The testing follows ANSI C63.26 Section 5.2
2. The transmitter output port was connected to the system simulator.
3. Set EUT at maximum power through the system simulator.
4. Select lowest, middle, and highest channels for each band and different modulation.
5. Measure and record the power level from the system simulator.

3.5 Peak-to-Average Ratio

3.5.1 Description of the PAR Measurement

Power Complementary Cumulative Distribution Function (CCDF) curves provide a means for characterizing the power peaks of a digitally modulated signal on a statistical basis. A CCDF curve depicts the probability of the peak signal amplitude exceeding the average power level. Most contemporary measurement instrumentation include the capability to produce CCDF curves for an input signal provided that the instrument's resolution bandwidth can be set wide enough to accommodate the entire input signal bandwidth. In measuring transmissions in this band using an average power technique, the peak-to-average ratio (PAR) of the transmission may not exceed 13 dB.

3.5.2 Test Procedures

1. The testing follows ANSI C63.26 Section 5.2.3.4 (CCDF).
2. The EUT was connected to spectrum and system simulator via a power divider.
3. Set the CCDF (Complementary Cumulative Distribution Function) option in spectrum analyzer.
4. The highest RF powers were measured and recorded the maximum PAPR level associated with a probability of 0.1 %.
5. Record the deviation as Peak to Average Ratio.

3.6 EIRP

3.6.1 Description of EIRP Limit

§ 27.50 (k)(3)

Mobile devices are limited to 1Watt (30 dBm) EIRP. Mobile devices operating in these bands must employ a means for limiting power to the minimum necessary for successful communications

3.6.2 Test Procedures

1. According to KDB 412172 D01 Power Approach,
2. $EIRP = P_T + G_T - L_C$, $ERP = EIRP - 2.15$, where
 P_T = transmitter output power in dBm
 G_T = gain of the transmitting antenna in dBi
 L_C = signal attenuation in the connecting cable between the transmitter and antenna in dB

3.7 Occupied Bandwidth

3.7.1 Description of Occupied Bandwidth Measurement

The occupied bandwidth is the width of a frequency band such that, below the lower and above the upper frequency limits, the mean powers emitted are each equal to a specified percentage 0.5% of the total mean transmitted power.

The 26 dB emission bandwidth is defined as the frequency range between two points, one above and one below the carrier frequency, at which the spectral density of the emission is attenuated 26 dB below the maximum in-band spectral density of the modulated signal. Spectral density (power per unit bandwidth) is to be measured with a detector of resolution bandwidth equal to approximately 1.0% of the emission bandwidth.

3.7.2 Test Procedures

1. The testing follows ANSI C63.26 Section 5.4
2. The EUT was connected to spectrum analyzer and system simulator via a power divider.
3. The spectrum analyzer center frequency is set to the nominal EUT channel center frequency. The span range for the spectrum analyzer shall be between two and five times the anticipated OBW.
4. The nominal resolution bandwidth (RBW) shall be in the range of 1 to 5 % of the anticipated OBW, and the VBW shall be at least 3 times the RBW.
5. Set the detection mode to peak, and the trace mode to max hold.
6. Determine the reference value: Set the EUT to transmit a modulated signal. Allow the trace to stabilize. Set the spectrum analyzer marker to the highest level of the displayed trace.
(this is the reference value)
7. Determine the “-26 dB down amplitude” as equal to (Reference Value – X).
8. Place two markers, one at the lowest and the other at the highest frequency of the envelope of the spectral display such that each marker is at or slightly below the “-X dB down amplitude” determined in step 6. If a marker is below this “-X dB down amplitude” value it shall be placed as close as possible to this value. The OBW is the positive frequency difference between the two markers.
9. Use the 99 % power bandwidth function of the spectrum analyzer and report the measured bandwidth.

3.8 Conducted Band Edge Measurement

3.8.1 Description of Conducted Band Edge Measurement

§ 27.53 (n)(2)

For mobile operations in the 3450-3550 MHz band, the conducted power of any emission outside the licensee's authorized bandwidth shall not exceed -13 dBm/MHz.

Compliance with this paragraph is based on the use of measurement instrumentation employing a resolution bandwidth of 1 megahertz or greater. However, in the 1 megahertz bands immediately outside and adjacent to the licensee's frequency block, a resolution bandwidth of at least one percent of the emission bandwidth of the fundamental emission of the transmitter may be employed, but limited to a maximum of 200 kHz. In the bands between 1 and 5 MHz removed from the licensee's frequency block, the minimum resolution bandwidth for the measurement shall be 500 kHz.

3.8.2 Test Procedures

1. The testing follows ANSI C63.26 section 5.7
2. The EUT was connected to spectrum analyzer and system simulator via a power divider.
3. The band edges of low and high channels for the highest RF powers were measured.
4. Set RBW \geq 1% EBW but limited to a maximum of 200 kHz in the 1MHz band immediately outside and adjacent to the band edge.
5. Beyond the 1 MHz and 5 MHz removed from the band edge, set RBW \geq 500KHz.
6. Beyond the 5 MHz removed from the band edge, set RBW = 1MHz.
7. Offset has included the duty factor for Band n77. Duty factor = $10 \log (1/x)$, where x is the measured duty cycle
8. Set spectrum analyzer with RMS detector.
9. The RF fundamental frequency should be excluded against the limit line in the operating frequency band.
10. Checked that all the results comply with the emission limit line.

3.9 Conducted Spurious Emission Measurement

3.9.1 Description of Conducted Spurious Emission Measurement

The power of any emission outside of the authorized operating frequency ranges shall not exceed -13 dBm/MHz.

It is measured by means of a calibrated spectrum analyzer and scanned from 30MHz up to a frequency including its 10th harmonic.

3.9.2 Test Procedures

1. The testing follows ANSI C63.26 section 5.7
2. The EUT was connected to spectrum analyzer and system simulator via a power divider.
3. The RF output of EUT was connected to the spectrum analyzer by RF cable and attenuator. The path loss was compensated to the results for each measurement.
4. The middle channel for the highest RF power within the transmitting frequency was measured.
5. The conducted spurious emission for the whole frequency range was taken.
6. Make the measurement with the spectrum analyzer's RBW = 1MHz, VBW = 3MHz.
7. Set spectrum analyzer with RMS detector.
8. Taking the record of maximum spurious emission.
9. The RF fundamental frequency should be excluded against the limit line in the operating frequency band.
10. Checked that all the results comply with the emission limit line.

3.10 Frequency Stability Measurement

3.10.1 Description of Frequency Stability Measurement

The frequency stability shall be measured by variation of ambient temperature and variation of primary supply voltage to ensure that the fundamental emission stays within the authorized frequency block.

3.10.2 Test Procedures for Temperature Variation

1. The testing follows ANSI C63.26 section 5.6.4
2. The EUT was set up in the thermal chamber and connected with the system simulator.
3. With power OFF, the temperature was decreased to -30°C and the EUT was stabilized before testing. Power was applied and the maximum change in frequency was recorded within one minute.
4. With power OFF, the temperature was raised in 10°C step up to 50°C . The EUT was stabilized at each step for at least half an hour. Power was applied and the maximum frequency change was recorded within one minute.

3.10.3 Test Procedures for Voltage Variation

1. The testing follows ANSI C63.26 section 5.6.5.
2. The EUT was placed in a temperature chamber at $20\pm 5^{\circ}\text{C}$ and connected with the system simulator.
3. The power supply voltage to the EUT was varied from 85% to 115% of the nominal value for other than hand carried battery equipment.
4. For hand carried, battery powered equipment, reduce the primary ac or dc supply voltage to the battery operating end point, which shall be specified by the manufacturer.
5. The variation in frequency was measured for the worst case.

4 Radiated Test Items

4.1 Measuring Instruments

See list of measuring instruments of this test report.

4.2 Test Setup

4.2.1 For radiated test below 30MHz



4.2.2 For radiated test from 30MHz to 1GHz

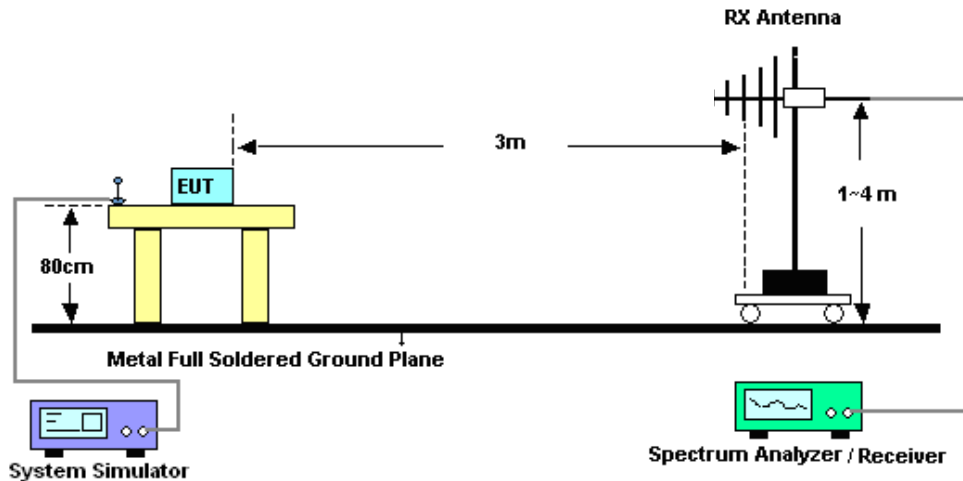

4.2.3 For radiated test above 1GHz



4.3 Test Result of Radiated Test

The low frequency, which started from 9 kHz to 30MHz, was pre-scanned and the result which was 20dB lower than the limit line was not reported.

Please refer to Appendix B.

4.4 Radiated Spurious Emission Measurement

4.4.1 Description of Radiated Spurious Emission

The radiated spurious emission was measured by substitution method according to ANSI/TIA-603-E. The power of any emission outside of the authorized operating frequency ranges shall not exceed -13 dBm/MHz.

The spectrum is scanned from 30 MHz up to a frequency including its 10th harmonic.

4.4.2 Test Procedures

1. The testing follows ANSI C63.26 Section 5.5
2. The EUT was placed on a turntable with 0.8 meter height for frequency below 1GHz and 1.5 meter height for frequency above 1GHz respectively above ground.
3. The EUT was set 3 meters from the receiving antenna mounted on the antenna tower.
4. The table was rotated 360 degrees to determine the position of the highest spurious emission.
5. The height of the receiving antenna is varied between 1m to 4m to search the maximum spurious emission for both horizontal and vertical polarizations.
6. During the measurement, the system simulator parameters were set to force the EUT transmitting at maximum output power.
7. Make the measurement with the spectrum analyzer's RBW = 1MHz, VBW = 3MHz, taking the record of maximum spurious emission.
8. A horn antenna was substituted in place of the EUT and was driven by a signal generator.
9. Tune the output power of signal generator to the same emission level with EUT maximum spurious emission.
$$\text{EIRP (dBm)} = \text{S.G. Power} - \text{Tx Cable Loss} + \text{Tx Antenna Gain}$$
$$\text{ERP (dBm)} = \text{EIRP} - 2.15$$
10. The RF fundamental frequency should be excluded against the limit line in the operating frequency band.



5 List of Measuring Equipment

Instrument	Manufacturer	Model No.	Serial No.	Characteristics	Calibration Date	Test Date	Due Date	Remark
EMI Test Receiver&SA	Agilent	N9038A	MY52260185	20Hz~26.5GHz	Dec. 27, 2021	Jul. 22, 2022~ Jul. 28, 2022	Dec. 26, 2022	Conducted (TH01-SZ)
Power Divider	TOJOIN	PS-2SM-04 265	60.06.020.007 7	0.4GHz~26.5GHz	Dec. 25, 2021	Jul. 22, 2022~ Jul. 28, 2022	Dec. 24, 2022	Conducted (TH01-SZ)
Thermal Chamber	Ten Billion Hongzhangroup	LP-150U	H2014081803	-40~+150°C	Jul. 13, 2022	Jul. 22, 2022~ Jul. 28, 2022	Jul. 12, 2023	Conducted (TH01-SZ)
EXA Spectrum Analyzer	Keysight	N9010B	MY57541079	10Hz-44G,MAX 30dB	Oct. 14, 2021	Jul. 13, 2022	Oct. 13, 2022	Radiation (03CH04-KS)
Loop Antenna	R&S	HFH2-Z2	100321	9kHz~30MHz	Oct. 30, 2021	Jul. 13, 2022	Oct. 29, 2022	Radiation (03CH04-KS)
Bilog Antenna	TeseQ	CBL6111D	49922	30MHz-1GHz	May 30, 2022	Jul. 13, 2022	May 29, 2023	Radiation (03CH04-KS)
Horn Antenna	Schwarzbeck	BBHA9120D	1284	1GHz~18GHz	Oct. 18, 2021	Jul. 13, 2022	Oct. 17, 2022	Radiation (03CH04-KS)
SHF-EHF Horn	Com-power	AH-840	101070	18GHz~40GHz	Jan. 05, 2022	Jul. 13, 2022	Jan. 04, 2023	Radiation (03CH04-KS)
Amplifier	SONOMA	310N	187289	9KHz-1GHz	Jan. 05, 2022	Jul. 13, 2022	Jan. 04, 2023	Radiation (03CH04-KS)
Amplifier	MITEQ	EM18G40G GA	060728	18~40GHz	Jan. 05, 2022	Jul. 13, 2022	Jan. 04, 2023	Radiation (03CH04-KS)
high gain Amplifier	MITEQ	AMF-7D-00 101800-30-1 0P	2025788	1Ghz-18Ghz	Jul. 30, 2021	Jul. 13, 2022	Jul. 29, 2022	Radiation (03CH04-KS)
Amplifier	Keysight	83017A	MY57280106	500MHz~26.5GHz	Oct. 13, 2021	Jul. 13, 2022	Oct. 12, 2022	Radiation (03CH04-KS)
AC Power Source	Chroma	61601	F104090004	N/A	NCR	Jul. 13, 2022	NCR	Radiation (03CH04-KS)
Turn Table	ChamPro	EM 1000-T	060762-T	0~360 degree	NCR	Jul. 13, 2022	NCR	Radiation (03CH04-KS)
Antenna Mast	ChamPro	EM 1000-A	060762-A	1 m~4 m	NCR	Jul. 13, 2022	NCR	Radiation (03CH04-KS)

NCR: No Calibration Required

6 Uncertainty of Evaluation

The measurement uncertainties shown below were calculated in accordance with the requirements of ANSI 63.26-2015. All the measurement uncertainty value were shown with a coverage K=2 to indicate 95% level of confidence. The measurement data show herein meets or exceeds the CISPR measurement uncertainty values specified in CISPR 16-4-2 and can be compared directly to specified limit to determine compliance.

Uncertainty of Conducted Measurement

Test Item	Uncertainty
Conducted Power	1.34 dB
Conducted Emissions	1.34 dB
Occupied Channel Bandwidth	0.012MHz
Conducted Power Spectral Density	1.32 dB
Frequency tolerance	1.30 ppm

Uncertainty of Radiated Emission Measurement (30 MHz ~ 1000 MHz)

Measuring Uncertainty for a Level of Confidence of 95% (U = 2Uc(y))	3.3dB
---	-------

Uncertainty of Radiated Emission Measurement (1 GHz ~ 18 GHz)

Measuring Uncertainty for a Level of Confidence of 95% (U = 2Uc(y))	2.8dB
---	-------

Uncertainty of Radiated Emission Measurement (18 GHz ~ 40 GHz)

Measuring Uncertainty for a Level of Confidence of 95% (U = 2Uc(y))	2.8dB
---	-------

----- THE END -----



Appendix A. Test Results of Conducted Test

Test Engineer :	Jung Kuo	Temperature :	22~23°C
		Relative Humidity :	40~42%

FR1 N77

Transmitter Conducted Output Power and EIRP

NR Band	SCS (kHz)	Bandwidth (MHz)	Arfcn	Freq (MHz)	Modulation	RB	Conducted Power (dBm)	EIRP (dBm)	EIRP (W)
77	30	10	630334	3455.01	DFT-s-OFDM QPSK	1@1	24.58	23.09	0.2037
77	30	10	630334	3455.01	DFT-s-OFDM 16 QAM	1@1	23.22	21.73	0.1489
77	30	10	633334	3500.01	DFT-s-OFDM QPSK	1@1	24.51	23.02	0.2004
77	30	10	633334	3500.01	DFT-s-OFDM 16 QAM	1@1	23.47	21.98	0.1578
77	30	10	636332	3544.98	DFT-s-OFDM QPSK	1@1	24.24	22.75	0.1884
77	30	10	636332	3544.98	DFT-s-OFDM 16 QAM	1@1	23.26	21.77	0.1503
77	30	15	630500	3457.5	DFT-s-OFDM QPSK	1@1	24.54	23.05	0.2018
77	30	15	630500	3457.5	DFT-s-OFDM 16 QAM	1@1	23.54	22.05	0.1603
77	30	15	633334	3500.01	DFT-s-OFDM QPSK	1@1	24.43	22.94	0.1968
77	30	15	633334	3500.01	DFT-s-OFDM 16 QAM	1@1	23.7	22.21	0.1663
77	30	15	636166	3542.49	DFT-s-OFDM QPSK	1@1	24.44	22.95	0.1972
77	30	15	636166	3542.49	DFT-s-OFDM 16 QAM	1@1	23.53	22.04	0.1600
77	30	20	630668	3460.02	DFT-s-OFDM QPSK	1@1	24.58	23.09	0.2037
77	30	20	630668	3460.02	DFT-s-OFDM 16 QAM	1@1	23.63	22.14	0.1637
77	30	20	633334	3500.01	DFT-s-OFDM QPSK	1@1	24.43	22.94	0.1968
77	30	20	633334	3500.01	DFT-s-OFDM 16 QAM	1@1	23.72	22.23	0.1671
77	30	20	636000	3540	DFT-s-OFDM QPSK	1@1	24.43	22.94	0.1968
77	30	20	636000	3540	DFT-s-OFDM 16 QAM	1@1	23.5	22.01	0.1589
77	30	30	631000	3465	DFT-s-OFDM QPSK	1@1	24.6	23.11	0.2046
77	30	30	631000	3465	DFT-s-OFDM 16 QAM	1@1	23.69	22.2	0.1660
77	30	30	633334	3500.01	DFT-s-OFDM QPSK	1@1	24.58	23.09	0.2037
77	30	30	633334	3500.01	DFT-s-OFDM 16 QAM	1@1	23.77	22.28	0.1690
77	30	30	635666	3534.99	DFT-s-OFDM QPSK	1@1	24.54	23.05	0.2018
77	30	30	635666	3534.99	DFT-s-OFDM 16 QAM	1@1	23.74	22.25	0.1679
77	30	40	631334	3470.01	DFT-s-OFDM QPSK	1@1	24.55	23.06	0.2023
77	30	40	631334	3470.01	DFT-s-OFDM 16 QAM	1@1	23.74	22.25	0.1679
77	30	40	633334	3500.01	DFT-s-OFDM QPSK	1@1	24.49	23	0.1995
77	30	40	633334	3500.01	DFT-s-OFDM 16 QAM	1@1	23.86	22.37	0.1726
77	30	40	635332	3529.98	DFT-s-OFDM QPSK	1@1	24.02	22.53	0.1791
77	30	40	635332	3529.98	DFT-s-OFDM 16 QAM	1@1	23.84	22.35	0.1718

77	30	50	631668	3475.02	DFT-s-OFDM QPSK	1@1	24.35	22.86	0.1932
77	30	50	631668	3475.02	DFT-s-OFDM 16 QAM	1@1	23.47	21.98	0.1578
77	30	50	633334	3500.01	DFT-s-OFDM QPSK	1@1	24.49	23	0.1995
77	30	50	633334	3500.01	DFT-s-OFDM 16 QAM	1@1	23.63	22.14	0.1637
77	30	50	635000	3525	DFT-s-OFDM QPSK	1@1	24.62	23.13	0.2056
77	30	50	635000	3525	DFT-s-OFDM 16 QAM	1@1	23.73	22.24	0.1675
77	30	60	632000	3480	DFT-s-OFDM QPSK	1@1	24.45	22.96	0.1977
77	30	60	632000	3480	DFT-s-OFDM 16 QAM	1@1	23.72	22.23	0.1671
77	30	60	633334	3500.01	DFT-s-OFDM QPSK	1@1	24.41	22.92	0.1959
77	30	60	633334	3500.01	DFT-s-OFDM 16 QAM	1@1	23.5	22.01	0.1589
77	30	60	634666	3519.99	DFT-s-OFDM QPSK	1@1	24.6	23.11	0.2046
77	30	60	634666	3519.99	DFT-s-OFDM 16 QAM	1@1	23.68	22.19	0.1656
77	30	70	632334	3485.01	DFT-s-OFDM QPSK	1@1	24.4	22.91	0.1954
77	30	70	632334	3485.01	DFT-s-OFDM 16 QAM	1@1	23.37	21.88	0.1542
77	30	70	633334	3500.01	DFT-s-OFDM QPSK	1@1	24.32	22.83	0.1919
77	30	70	633334	3500.01	DFT-s-OFDM 16 QAM	1@1	23.55	22.06	0.1607
77	30	70	634332	3514.98	DFT-s-OFDM QPSK	1@1	24.41	22.92	0.1959
77	30	70	634332	3514.98	DFT-s-OFDM 16 QAM	1@1	23.58	22.09	0.1618
77	30	80	632668	3490.02	DFT-s-OFDM QPSK	1@1	24.18	22.69	0.1858
77	30	80	632668	3490.02	DFT-s-OFDM 16 QAM	1@1	23.35	21.86	0.1535
77	30	80	633334	3500.01	DFT-s-OFDM QPSK	1@1	24.24	22.75	0.1884
77	30	80	633334	3500.01	DFT-s-OFDM 16 QAM	1@1	23.42	21.93	0.1560
77	30	80	634000	3510	DFT-s-OFDM QPSK	1@1	24.29	22.8	0.1905
77	30	80	634000	3510	DFT-s-OFDM 16 QAM	1@1	23.48	21.99	0.1581
77	30	90	633000	3495	DFT-s-OFDM QPSK	1@1	24.25	22.76	0.1888
77	30	90	633000	3495	DFT-s-OFDM 16 QAM	1@1	23.49	22	0.1585
77	30	90	633334	3500.01	DFT-s-OFDM QPSK	1@1	24.23	22.74	0.1879
77	30	90	633334	3500.01	DFT-s-OFDM 16 QAM	1@1	23.42	21.93	0.1560
77	30	90	633666	3504.99	DFT-s-OFDM QPSK	1@1	24.3	22.81	0.1910
77	30	90	633666	3504.99	DFT-s-OFDM 16 QAM	1@1	23.4	21.91	0.1552
77	30	100	633334	3500.01	DFT-s-OFDM PI/2 BPSK	135@67	24.63	23.14	0.2061
77	30	100	633334	3500.01	DFT-s-OFDM PI/2 BPSK	1@1	24.34	22.85	0.1928
77	30	100	633334	3500.01	DFT-s-OFDM PI/2 BPSK	1@271	24.03	22.54	0.1795
77	30	100	633334	3500.01	DFT-s-OFDM QPSK	1@1	24.2	22.71	0.1866
77	30	100	633334	3500.01	DFT-s-OFDM QPSK	1@271	23.92	22.43	0.1750
77	30	100	633334	3500.01	DFT-s-OFDM 16 QAM	135@67	23.3	21.81	0.1517

77	30	100	633334	3500.01	DFT-s-OFDM 16 QAM	1@1	23.32	21.83	0.1524
77	30	100	633334	3500.01	DFT-s-OFDM 16 QAM	1@271	23.12	21.63	0.1455
77	30	100	633334	3500.01	DFT-s-OFDM 64 QAM	135@67	21.74	20.25	0.1059
77	30	100	633334	3500.01	DFT-s-OFDM 64 QAM	1@1	21.77	20.28	0.1067
77	30	100	633334	3500.01	DFT-s-OFDM 64 QAM	1@271	21.52	20.03	0.1007
77	30	100	633334	3500.01	DFT-s-OFDM 256 QAM	135@67	19.89	18.4	0.0692
77	30	100	633334	3500.01	DFT-s-OFDM 256 QAM	1@1	19.58	18.09	0.0644
77	30	100	633334	3500.01	DFT-s-OFDM 256 QAM	1@271	19.37	17.88	0.0614
77	30	100	633334	3500.01	CP-OFDM QPSK	137@68	22.82	21.33	0.1358
77	30	100	633334	3500.01	CP-OFDM QPSK	1@1	22.69	21.2	0.1318
77	30	100	633334	3500.01	CP-OFDM QPSK	1@271	22.44	20.95	0.1245

Frequency Stability

NR Band	SCS (kHz)	Bandwidth (MHz)	Arfcn	Freq (MHz)	Modulation	RB	Deviation (ppm)	Verdict	Environment
77	30	20	633334	3500.01	DFT-s-OFDM QPSK	50@0	0.0031	PASS	NV
77	30	20	633334	3500.01	DFT-s-OFDM QPSK	50@0	0.0027	PASS	LV
77	30	20	633334	3500.01	DFT-s-OFDM QPSK	50@0	0.0058	PASS	HV
77	30	20	633334	3500.01	DFT-s-OFDM QPSK	50@0	0.0054	PASS	-30°C
77	30	20	633334	3500.01	DFT-s-OFDM QPSK	50@0	0.0033	PASS	-20°C
77	30	20	633334	3500.01	DFT-s-OFDM QPSK	50@0	0.0042	PASS	-10°C
77	30	20	633334	3500.01	DFT-s-OFDM QPSK	50@0	0.0041	PASS	0°C
77	30	20	633334	3500.01	DFT-s-OFDM QPSK	50@0	0.0066	PASS	10°C
77	30	20	633334	3500.01	DFT-s-OFDM QPSK	50@0	0.0031	PASS	20°C
77	30	20	633334	3500.01	DFT-s-OFDM QPSK	50@0	0.0023	PASS	30°C
77	30	20	633334	3500.01	DFT-s-OFDM QPSK	50@0	0.0025	PASS	40°C
77	30	20	633334	3500.01	DFT-s-OFDM QPSK	50@0	0.0035	PASS	50°C

Peak to Average Ratio

NR Band	SCS (kHz)	Bandwidth (MHz)	Arfcn	Freq (MHz)	Modulation	RB	Result (dB)	Limit (dB)	Verdict
77	30	20	630668	3460.02	DFT-s-OFDM PI/2 BPSK	50@0	6.3	13	PASS
77	30	20	630668	3460.02	DFT-s-OFDM PI/2 BPSK	1@0	6.87	13	PASS
77	30	20	630668	3460.02	DFT-s-OFDM QPSK	50@0	7.16	13	PASS
77	30	20	630668	3460.02	DFT-s-OFDM QPSK	1@0	7.59	13	PASS
77	30	20	633334	3500.01	DFT-s-OFDM PI/2 BPSK	50@0	5.89	13	PASS
77	30	20	633334	3500.01	DFT-s-OFDM PI/2 BPSK	1@0	6.78	13	PASS
77	30	20	633334	3500.01	DFT-s-OFDM QPSK	50@0	6.61	13	PASS
77	30	20	633334	3500.01	DFT-s-OFDM QPSK	1@0	7.47	13	PASS
77	30	20	636000	3540.0	DFT-s-OFDM PI/2 BPSK	50@0	6.12	13	PASS
77	30	20	636000	3540.0	DFT-s-OFDM PI/2 BPSK	1@0	6.84	13	PASS
77	30	20	636000	3540.0	DFT-s-OFDM QPSK	50@0	6.96	13	PASS
77	30	20	636000	3540.0	DFT-s-OFDM QPSK	1@0	6.67	13	PASS

N77(20M)_DFT-s-OFDM_PI_2-BPSK_Outer_Full_Low_CH

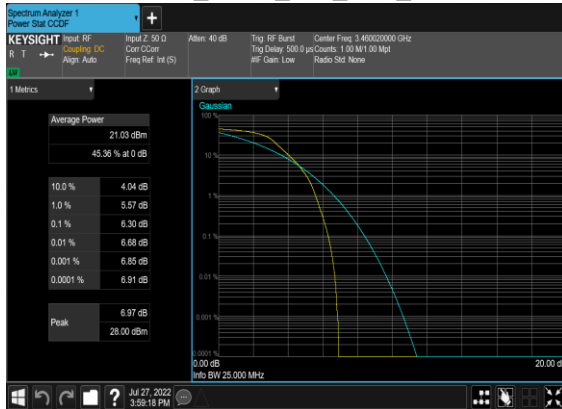

N77(20M)_DFT-s-OFDM_PI_2-BPSK_Edge_1RB_Left_Low_CH

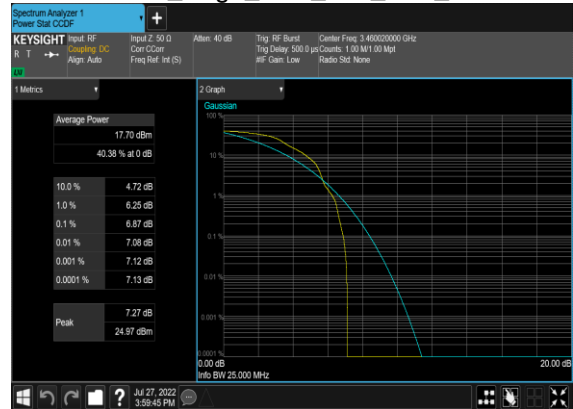

N77(20M)_DFT-s-OFDM_QPSK_Outer_Full_Low_CH

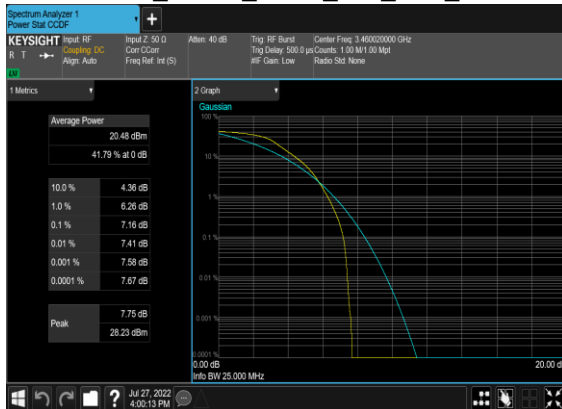

N77(20M)_DFT-s-OFDM_QPSK_Edge_1RB_Left_Low_CH

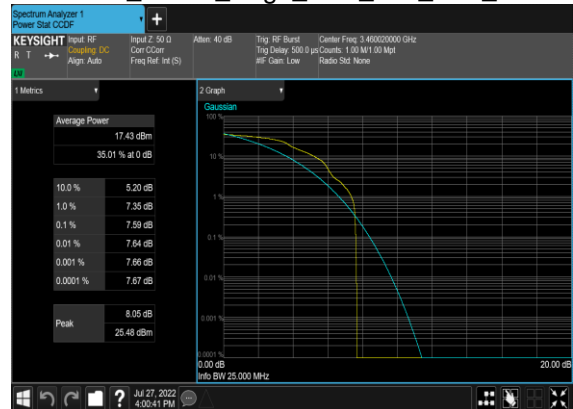

N77(20M)_DFT-s-OFDM_PI_2-BPSK_Outer_Full_Mid_CH

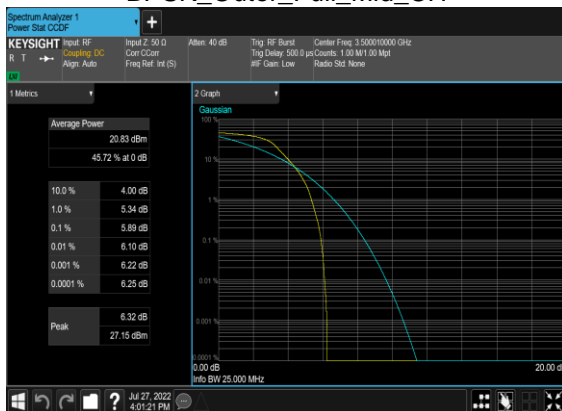

N77(20M)_DFT-s-OFDM_PI_2-BPSK_Edge_1RB_Left_Mid_CH

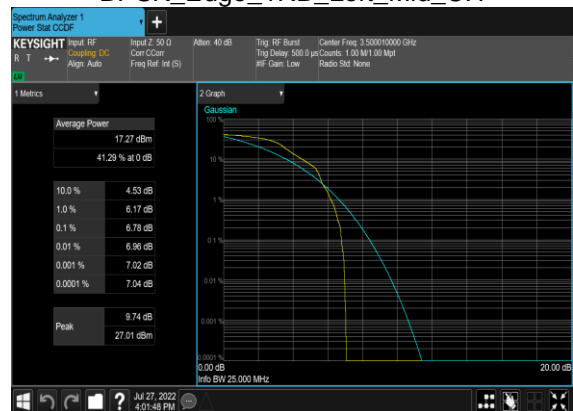

N77(20M)_DFT-s-OFDM_QPSK_Outer_Full_Mid_CH

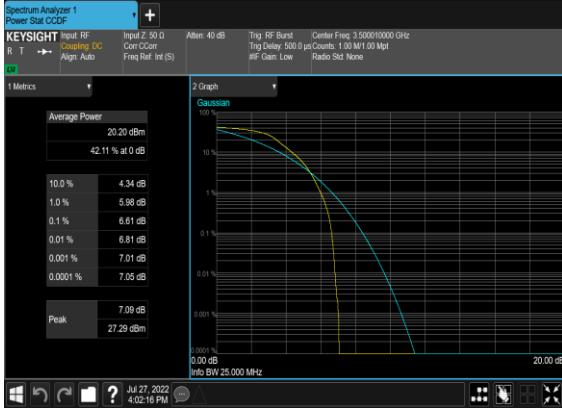

N77(20M)_DFT-s-OFDM_QPSK_Edge_1RB_Left_Mid_CH

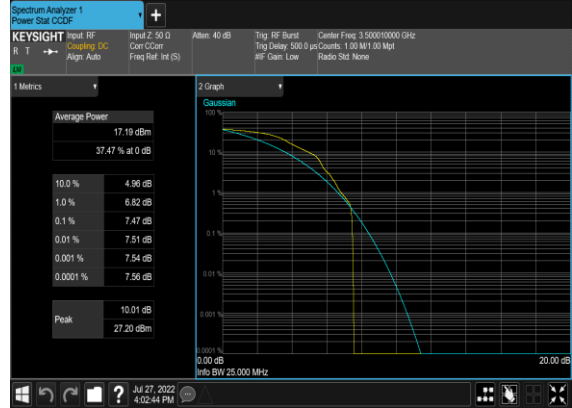

N77(20M)_DFT-s-OFDM_PI_2-BPSK_Outer_Full_High_CH

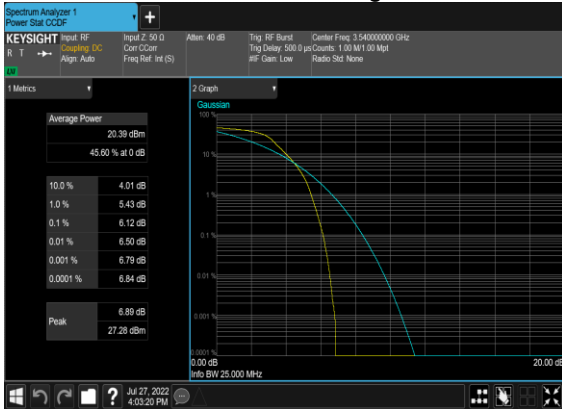

N77(20M)_DFT-s-OFDM_PI_2-BPSK_Edge_1RB_Left_High_CH

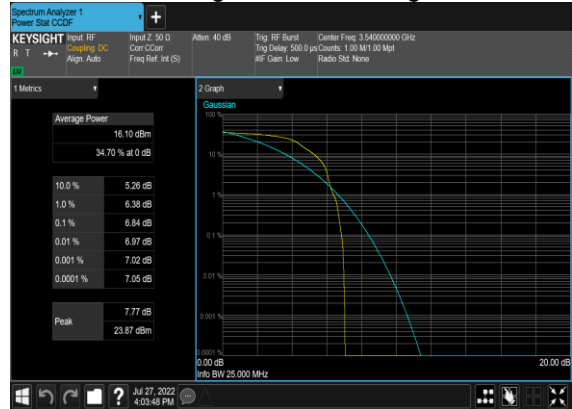

N77(20M)_DFT-s-OFDM_QPSK_Outer_Full_High_CH

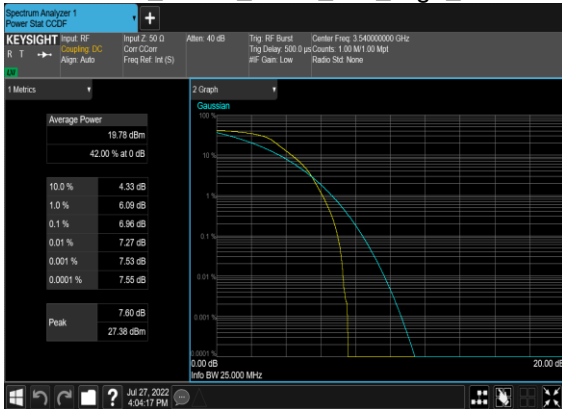

N77(20M)_DFT-s-OFDM_QPSK_Edge_1RB_Left_High_CH

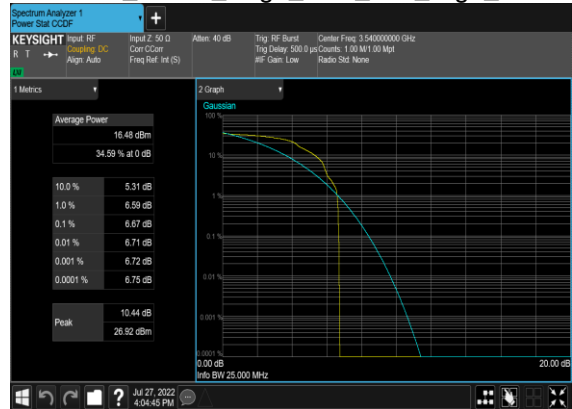

Occupied Bandwidth

NR Band	SCS (kHz)	Bandwidth (MHz)	Arfcn	Freq (MHz)	Modulation	RB	OBW (MHz)	26dB OBW (MHz)
77	30	10	633334	3500.01	DFT-s-OFDM PI/2 BPSK	24@0	8.5772	9.67
77	30	10	633334	3500.01	DFT-s-OFDM QPSK	24@0	8.5799	9.911
77	30	10	633334	3500.01	CP-OFDM QPSK	24@0	8.5828	10.08
77	30	10	633334	3500.01	CP-OFDM 16 QAM	24@0	8.6131	10.24
77	30	10	633334	3500.01	CP-OFDM 64 QAM	24@0	8.6211	9.881
77	30	10	633334	3500.01	CP-OFDM 256 QAM	24@0	8.5783	9.456
77	30	15	633334	3500.01	DFT-s-OFDM PI/2 BPSK	36@0	12.857	14.09
77	30	15	633334	3500.01	DFT-s-OFDM QPSK	36@0	12.865	14.13
77	30	15	633334	3500.01	CP-OFDM QPSK	38@0	13.586	15.21
77	30	15	633334	3500.01	CP-OFDM 16 QAM	38@0	13.613	14.62
77	30	15	633334	3500.01	CP-OFDM 64 QAM	38@0	13.627	15.2
77	30	15	633334	3500.01	CP-OFDM 256 QAM	38@0	13.573	14.82
77	30	20	633334	3500.01	DFT-s-OFDM PI/2 BPSK	50@0	17.797	19.08
77	30	20	633334	3500.01	DFT-s-OFDM QPSK	50@0	17.81	19.2
77	30	20	633334	3500.01	CP-OFDM QPSK	51@0	18.237	21.38
77	30	20	633334	3500.01	CP-OFDM 16 QAM	51@0	18.226	19.65
77	30	20	633334	3500.01	CP-OFDM 64 QAM	51@0	18.237	19.97
77	30	20	633334	3500.01	CP-OFDM 256 QAM	51@0	18.203	19.74
77	30	30	633334	3500.01	DFT-s-OFDM PI/2 BPSK	75@0	26.742	28.41
77	30	30	633334	3500.01	DFT-s-OFDM QPSK	75@0	26.792	27.97
77	30	30	633334	3500.01	CP-OFDM QPSK	78@0	27.897	30.1
77	30	30	633334	3500.01	CP-OFDM 16 QAM	78@0	27.93	29.74
77	30	30	633334	3500.01	CP-OFDM 64 QAM	78@0	27.87	29.31
77	30	30	633334	3500.01	CP-OFDM 256 QAM	78@0	27.869	29.47
77	30	40	633334	3500.01	DFT-s-OFDM PI/2 BPSK	100@0	35.761	37.75

77	30	40	633334	3500.01	DFT-s-OFDM QPSK	100@0	35.74	37.85
77	30	40	633334	3500.01	CP-OFDM QPSK	106@0	37.872	40.31
77	30	40	633334	3500.01	CP-OFDM 16 QAM	106@0	37.922	39.63
77	30	40	633334	3500.01	CP-OFDM 64 QAM	106@0	37.87	39.49
77	30	40	633334	3500.01	CP-OFDM 256 QAM	106@0	37.766	39.75
77	30	50	633334	3500.01	DFT-s-OFDM PI/2 BPSK	128@0	45.777	47.81
77	30	50	633334	3500.01	DFT-s-OFDM QPSK	128@0	45.763	47.59
77	30	50	633334	3500.01	CP-OFDM QPSK	133@0	47.453	49.86
77	30	50	633334	3500.01	CP-OFDM 16 QAM	133@0	47.542	49.45
77	30	50	633334	3500.01	CP-OFDM 64 QAM	133@0	47.467	49.41
77	30	50	633334	3500.01	CP-OFDM 256 QAM	133@0	47.505	49.55
77	30	60	633334	3500.01	DFT-s-OFDM PI/2 BPSK	162@0	57.934	60.07
77	30	60	633334	3500.01	DFT-s-OFDM QPSK	162@0	57.882	60.24
77	30	60	633334	3500.01	CP-OFDM QPSK	162@0	57.87	60.43
77	30	60	633334	3500.01	CP-OFDM 16 QAM	162@0	57.783	60.34
77	30	60	633334	3500.01	CP-OFDM 64 QAM	162@0	57.846	60.17
77	30	60	633334	3500.01	CP-OFDM 256 QAM	162@0	57.831	60.06
77	30	70	633334	3500.01	DFT-s-OFDM PI/2 BPSK	180@0	64.427	66.55
77	30	70	633334	3500.01	DFT-s-OFDM QPSK	180@0	64.279	66.49
77	30	70	633334	3500.01	CP-OFDM QPSK	189@0	67.62	69.93
77	30	70	633334	3500.01	CP-OFDM 16 QAM	189@0	67.418	69.77
77	30	70	633334	3500.01	CP-OFDM 64 QAM	189@0	67.473	76.04
77	30	70	633334	3500.01	CP-OFDM 256 QAM	189@0	67.531	69.85
77	30	80	633334	3500.01	DFT-s-OFDM PI/2 BPSK	216@0	77.285	80.16
77	30	80	633334	3500.01	DFT-s-OFDM QPSK	216@0	77.19	79.69
77	30	80	633334	3500.01	CP-OFDM QPSK	217@0	77.451	80.11
77	30	80	633334	3500.01	CP-OFDM 16 QAM	217@0	77.664	80.07

77	30	80	633334	3500.01	CP-OFDM 64 QAM	217@0	77.592	80.24
77	30	80	633334	3500.01	CP-OFDM 256 QAM	217@0	77.393	80.17
77	30	90	633334	3500.01	DFT-s-OFDM PI/2 BPSK	240@0	85.656	88.55
77	30	90	633334	3500.01	DFT-s-OFDM QPSK	240@0	85.725	88.59
77	30	90	633334	3500.01	CP-OFDM QPSK	245@0	87.454	90.59
77	30	90	633334	3500.01	CP-OFDM 16 QAM	245@0	87.38	90.75
77	30	90	633334	3500.01	CP-OFDM 64 QAM	245@0	87.426	90.44
77	30	90	633334	3500.01	CP-OFDM 256 QAM	245@0	87.662	90.43
77	30	100	633334	3500.01	DFT-s-OFDM PI/2 BPSK	270@0	96.411	99.65
77	30	100	633334	3500.01	DFT-s-OFDM QPSK	270@0	96.537	99.51
77	30	100	633334	3500.01	CP-OFDM QPSK	273@0	97.5	100.6
77	30	100	633334	3500.01	CP-OFDM 16 QAM	273@0	97.452	100.8
77	30	100	633334	3500.01	CP-OFDM 64 QAM	273@0	97.465	100.5
77	30	100	633334	3500.01	CP-OFDM 256 QAM	273@0	97.367	100.6

N77(10M)_DFT-s-OFDM_PI_2- BPSK_Outer_Full_Mid_CH



N77(10M)_DFT-s- OFDM_QPSK_Outer_Full_Mid_CH

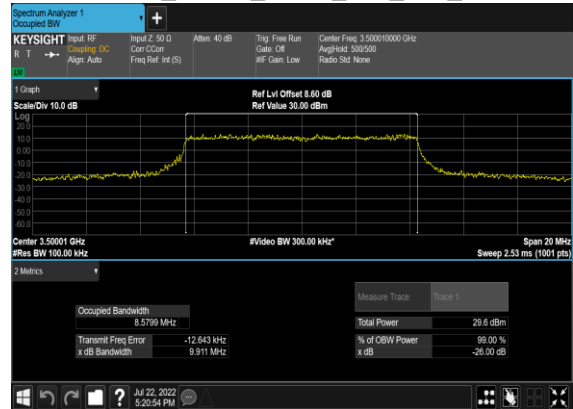

N77(10M)_CP- OFDM_QPSK_Outer_Full_Mid_CH

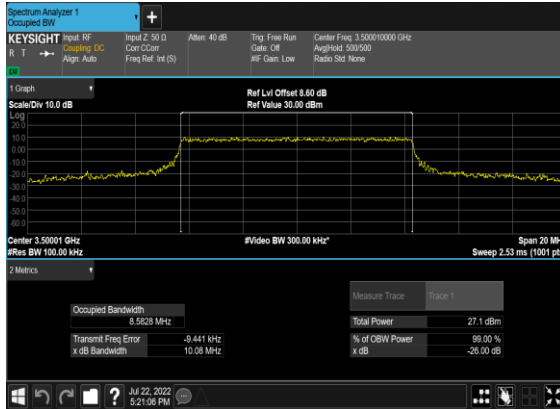

N77(10M)_CP-OFDM_16 QAM_Outer_Full_Mid_CH

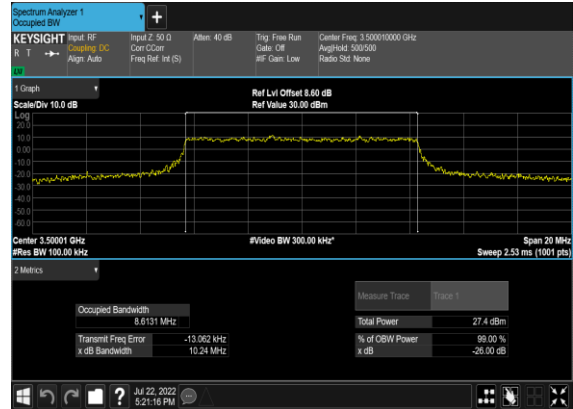

N77(10M)_CP-OFDM_64 QAM_Outer_Full_Mid_CH

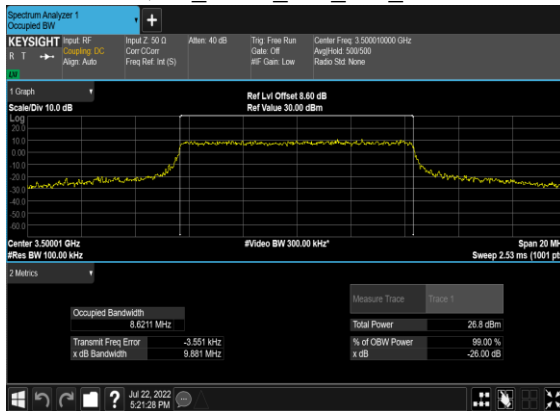

N77(10M)_CP-OFDM_256 QAM_Outer_Full_Mid_CH

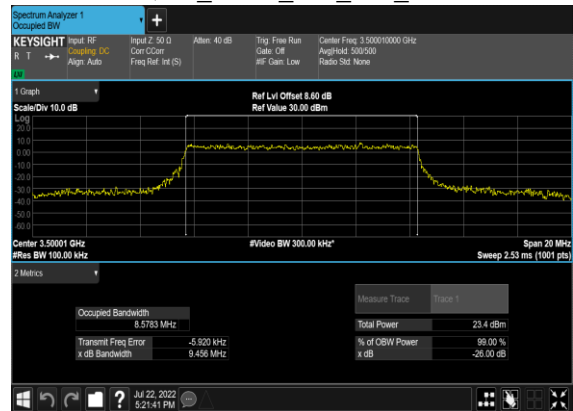

N77(15M)_DFT-s-OFDM_PI_2-
BPSK_Outer_Full_Mid_CH

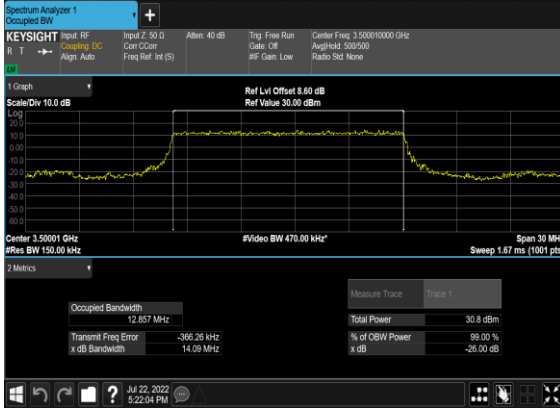

N77(15M)_DFT-s-
OFDM_QPSK_Outer_Full_Mid_CH

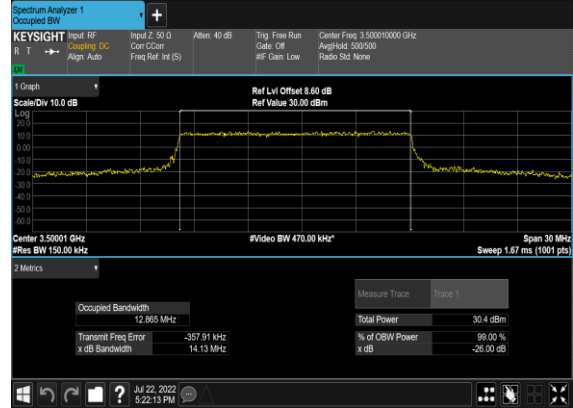

N77(15M)_CP-
OFDM_QPSK_Outer_Full_Mid_CH

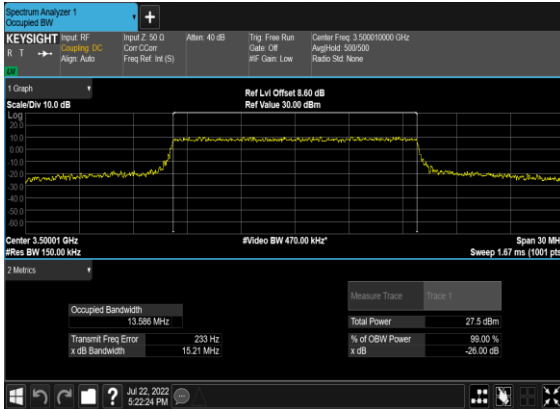

N77(15M)_CP-OFDM_16
QAM_Outer_Full_Mid_CH

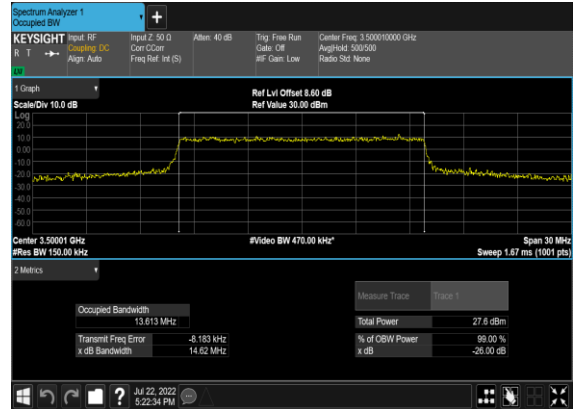

N77(15M)_CP-OFDM_64
QAM_Outer_Full_Mid_CH

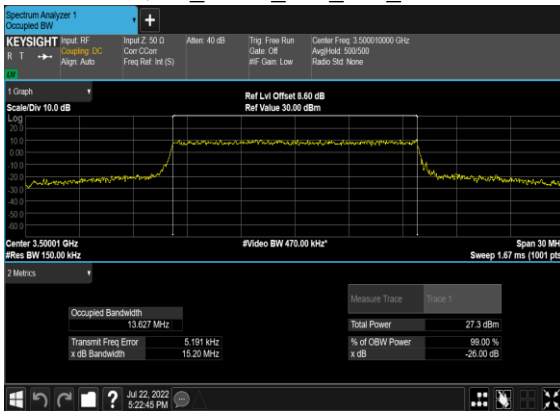

N77(15M)_CP-OFDM_256
QAM_Outer_Full_Mid_CH

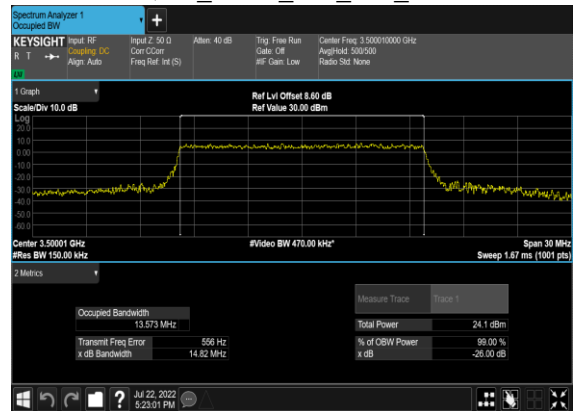

N77(20M)_DFT-s-OFDM_PI_2-BPSK_Outer_Full_Mid_CH

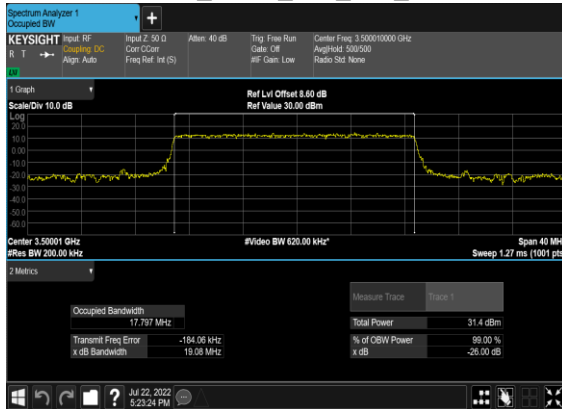

N77(20M)_DFT-s-OFDM_QPSK_Outer_Full_Mid_CH

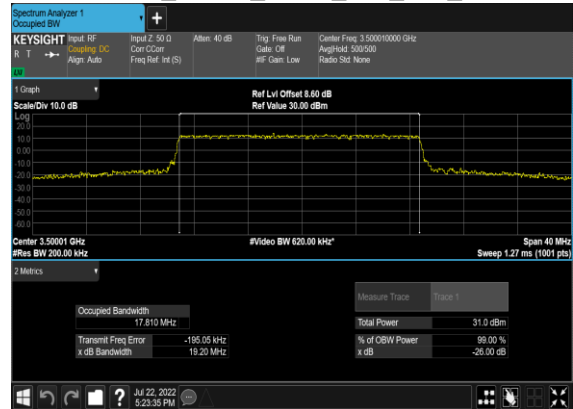

N77(20M)_CP-OFDM_QPSK_Outer_Full_Mid_CH

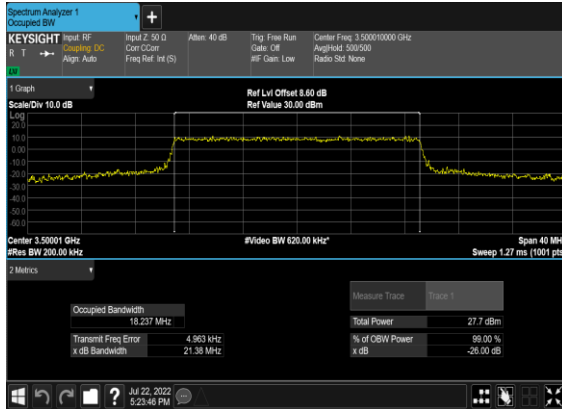

N77(20M)_CP-OFDM_16QAM_Outer_Full_Mid_CH

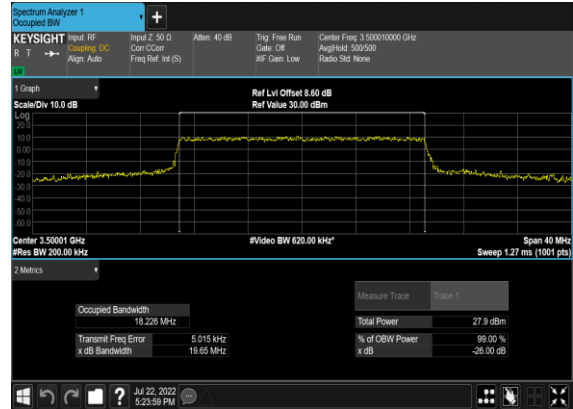

N77(20M)_CP-OFDM_64QAM_Outer_Full_Mid_CH



N77(20M)_CP-OFDM_256QAM_Outer_Full_Mid_CH

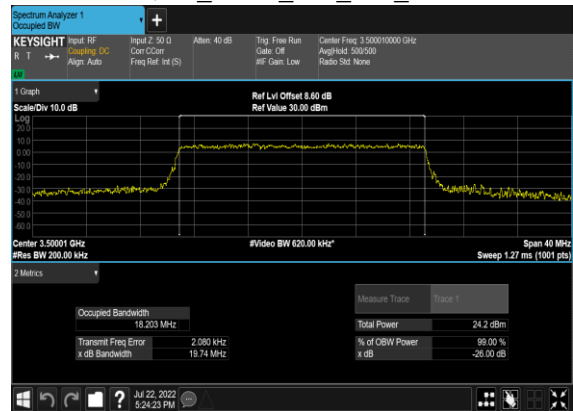

N77(30M)_DFT-s-OFDM_PI_2-
BPSK_Outer_Full_Mid_CH



N77(30M)_DFT-s-
OFDM_QPSK_Outer_Full_Mid_CH

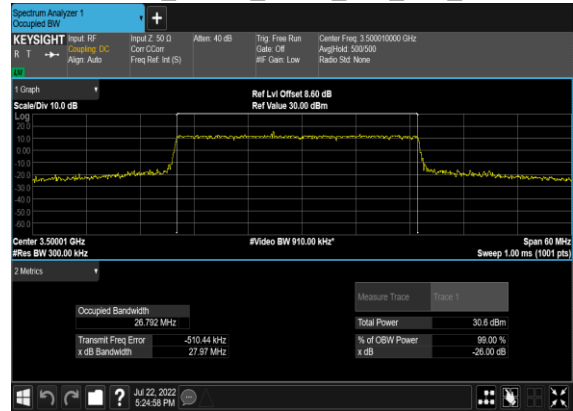

N77(30M)_CP-
OFDM_QPSK_Outer_Full_Mid_CH

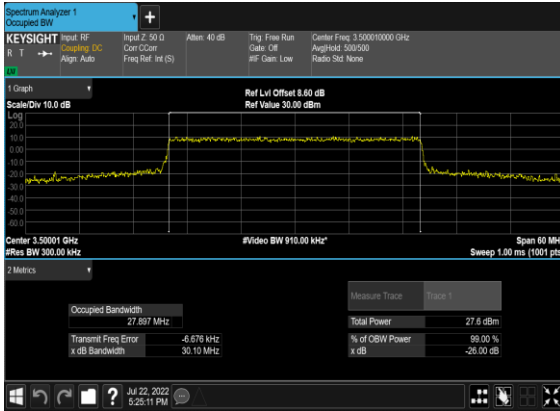

N77(30M)_CP-OFDM_16
QAM_Outer_Full_Mid_CH

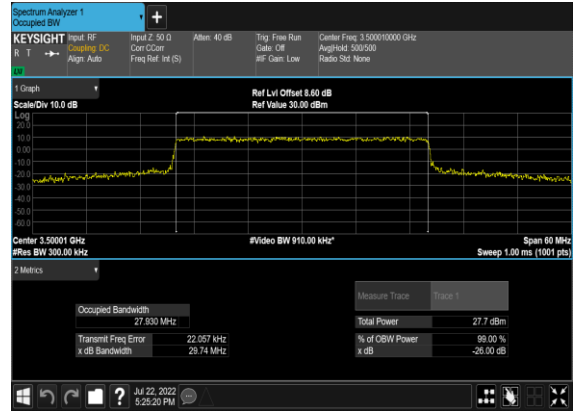

N77(30M)_CP-OFDM_64
QAM_Outer_Full_Mid_CH

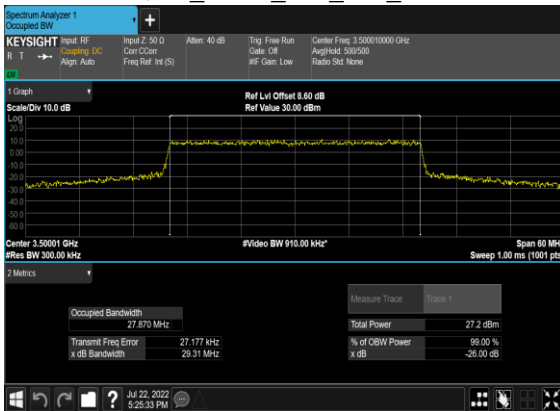

N77(30M)_CP-OFDM_256
QAM_Outer_Full_Mid_CH

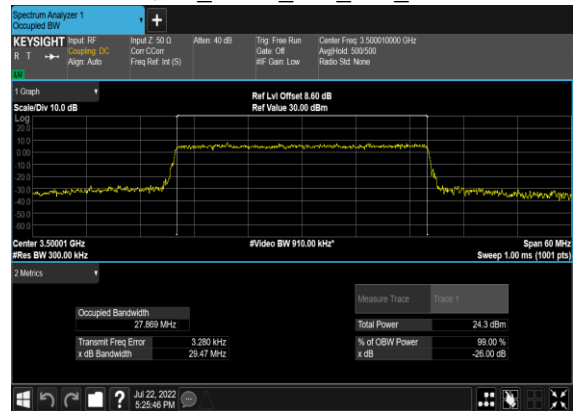

N77(40M)_DFT-s-OFDM_PI_2-BPSK_Outer_Full_Mid_CH

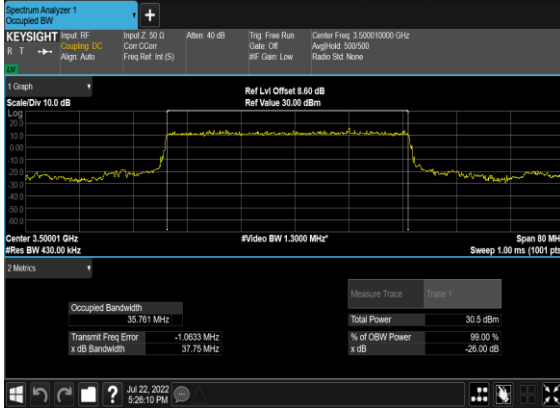

N77(40M)_DFT-s-OFDM_QPSK_Outer_Full_Mid_CH

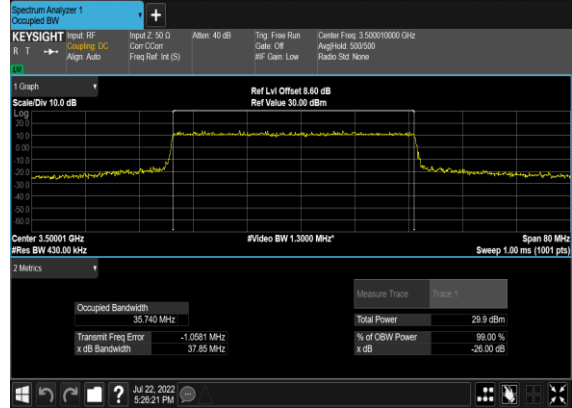

N77(40M)_CP-OFDM_QPSK_Outer_Full_Mid_CH

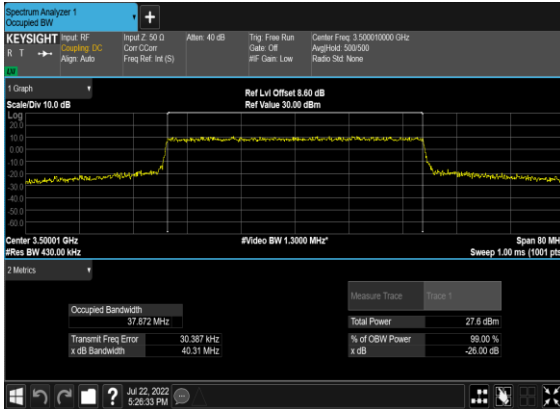

N77(40M)_CP-OFDM_16QAM_Outer_Full_Mid_CH



N77(40M)_CP-OFDM_64QAM_Outer_Full_Mid_CH

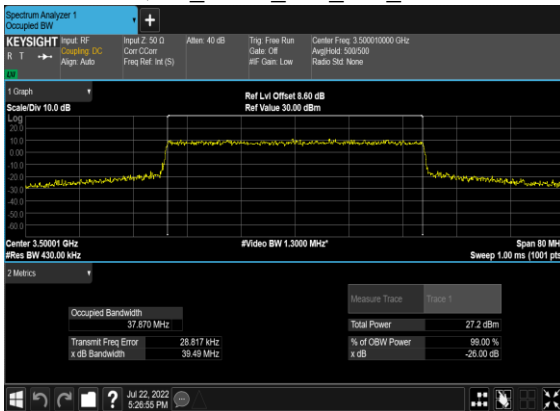

N77(40M)_CP-OFDM_256QAM_Outer_Full_Mid_CH

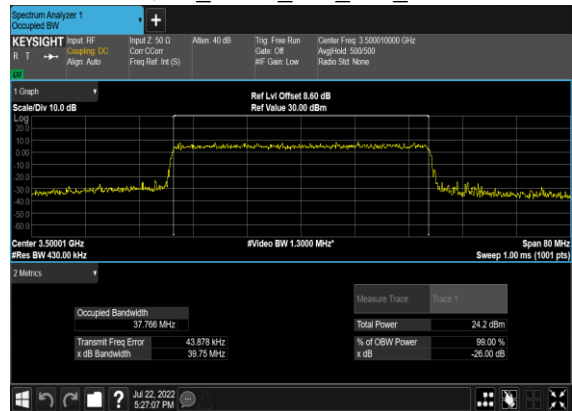

N77(50M)_DFT-s-OFDM_PI_2-
BPSK_Outer_Full_Mid_CH

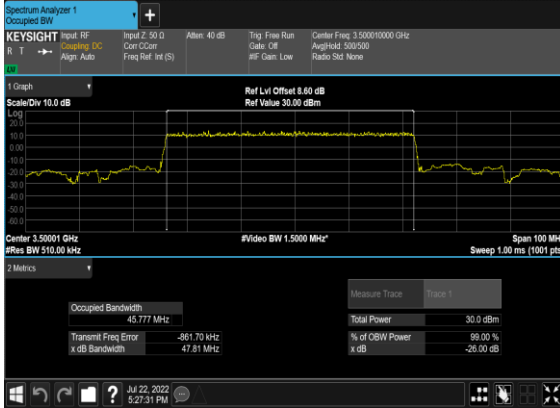

N77(50M)_DFT-s-
OFDM_QPSK_Outer_Full_Mid_CH

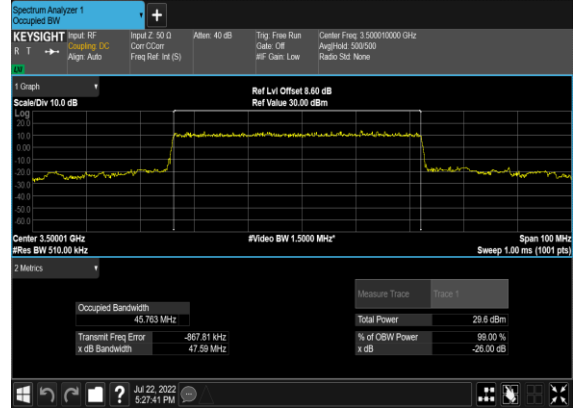

N77(50M)_CP-
OFDM_QPSK_Outer_Full_Mid_CH



N77(50M)_CP-OFDM_16
QAM_Outer_Full_Mid_CH

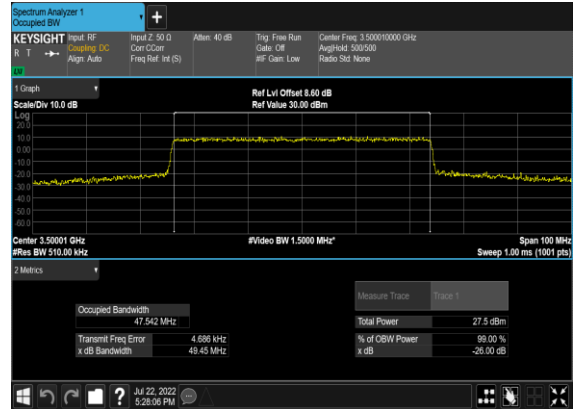

N77(50M)_CP-OFDM_64
QAM_Outer_Full_Mid_CH

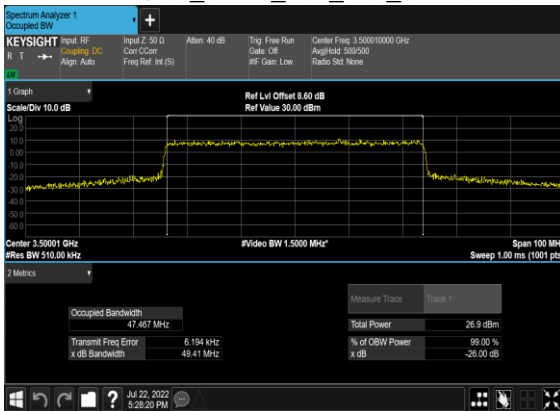

N77(50M)_CP-OFDM_256
QAM_Outer_Full_Mid_CH

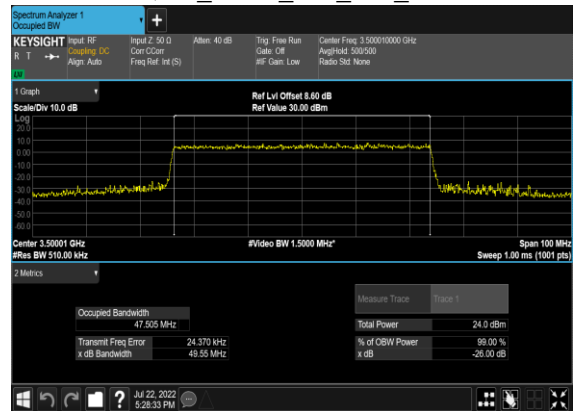

N77(60M)_DFT-s-OFDM_PI_2-
BPSK_Outer_Full_Mid_CH

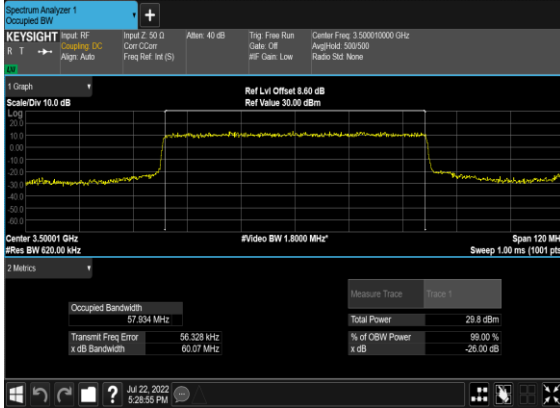

N77(60M)_DFT-s-
OFDM_QPSK_Outer_Full_Mid_CH

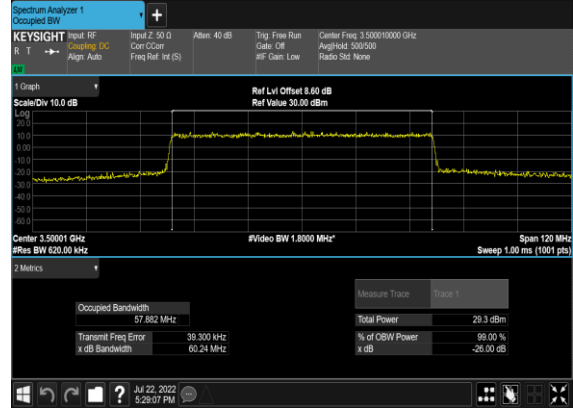

N77(60M)_CP-
OFDM_QPSK_Outer_Full_Mid_CH



N77(60M)_CP-OFDM_16
QAM_Outer_Full_Mid_CH

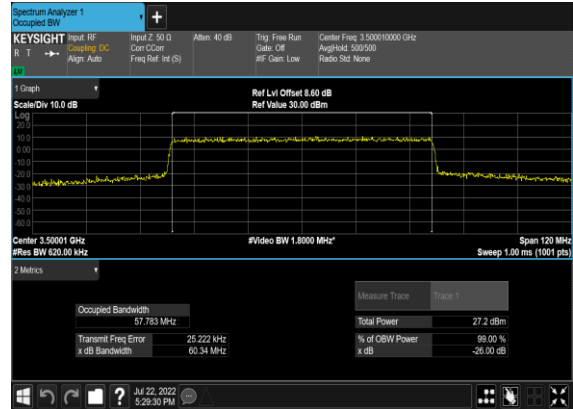

N77(60M)_CP-OFDM_64
QAM_Outer_Full_Mid_CH

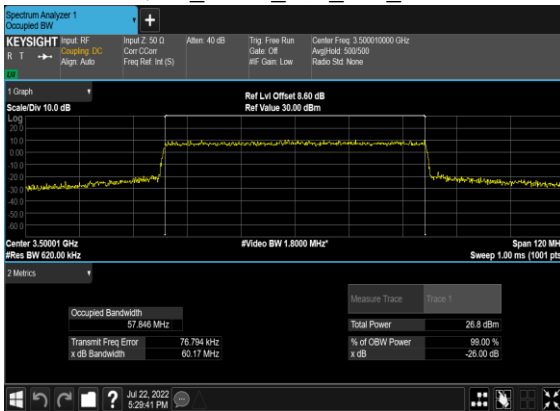

N77(60M)_CP-OFDM_256
QAM_Outer_Full_Mid_CH

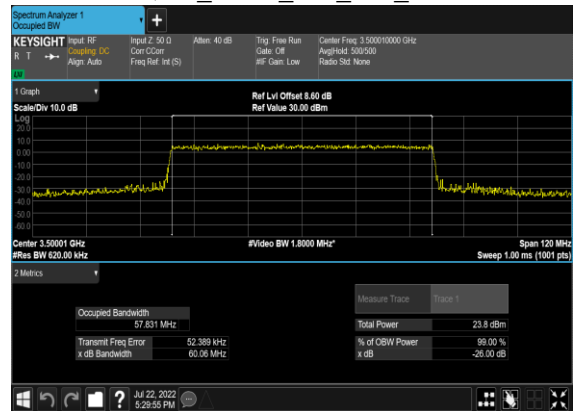

N77(70M)_DFT-s-OFDM_PI_2-BPSK_Outer_Full_Mid_CH

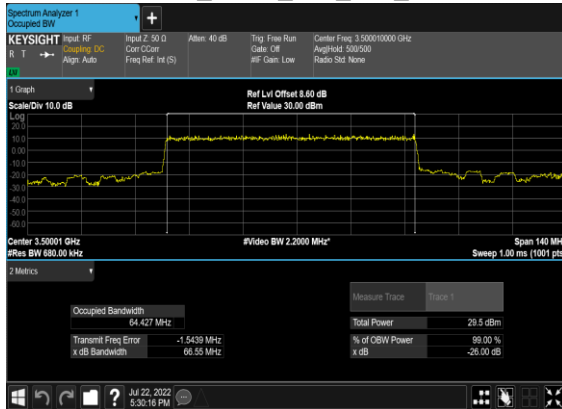

N77(70M)_DFT-s-OFDM_QPSK_Outer_Full_Mid_CH

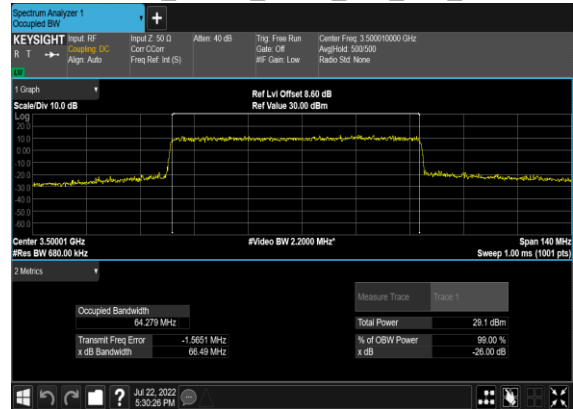

N77(70M)_CP-OFDM_QPSK_Outer_Full_Mid_CH



N77(70M)_CP-OFDM_16QAM_Outer_Full_Mid_CH

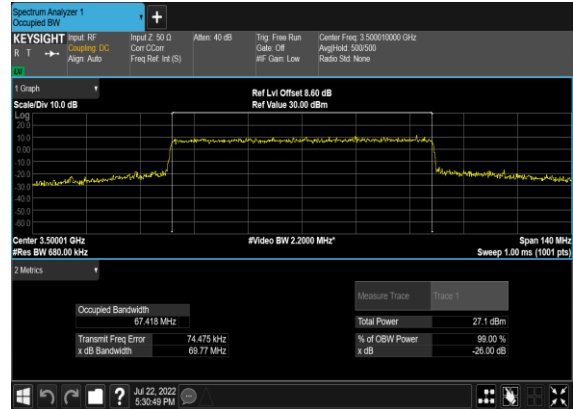

N77(70M)_CP-OFDM_64QAM_Outer_Full_Mid_CH

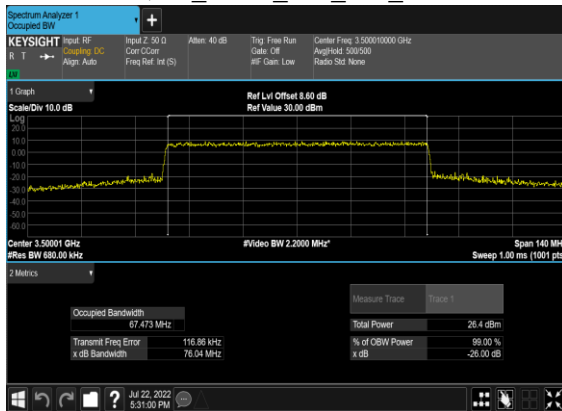

N77(70M)_CP-OFDM_256QAM_Outer_Full_Mid_CH

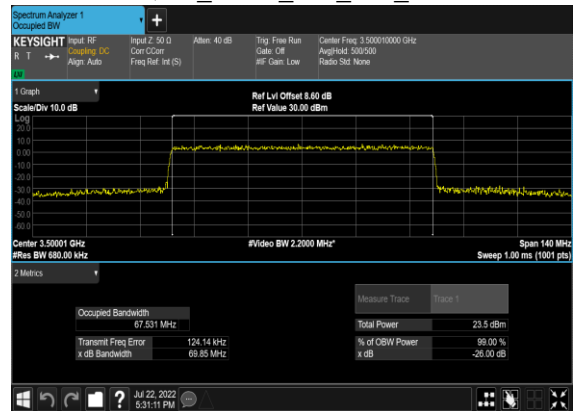

N77(80M)_DFT-s-OFDM_PI_2-BPSK_Outer_Full_Mid_CH

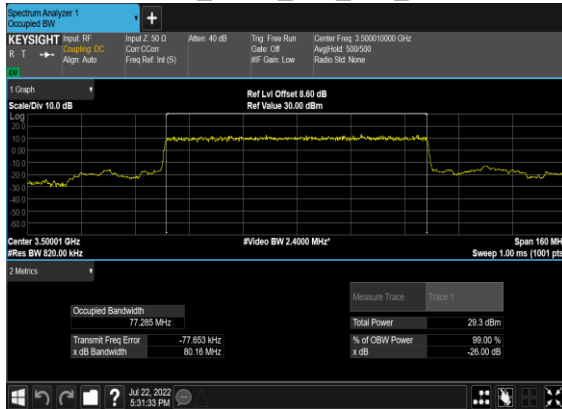

N77(80M)_DFT-s-OFDM_QPSK_Outer_Full_Mid_CH

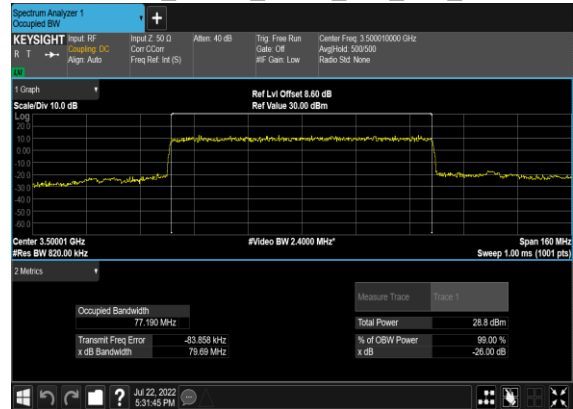

N77(80M)_CP-OFDM_QPSK_Outer_Full_Mid_CH



N77(80M)_CP-OFDM_16QAM_Outer_Full_Mid_CH

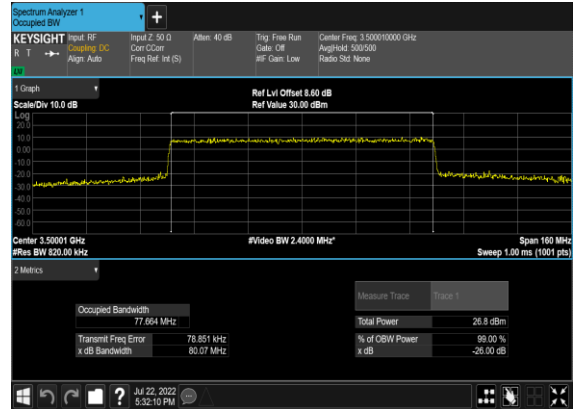

N77(80M)_CP-OFDM_64QAM_Outer_Full_Mid_CH

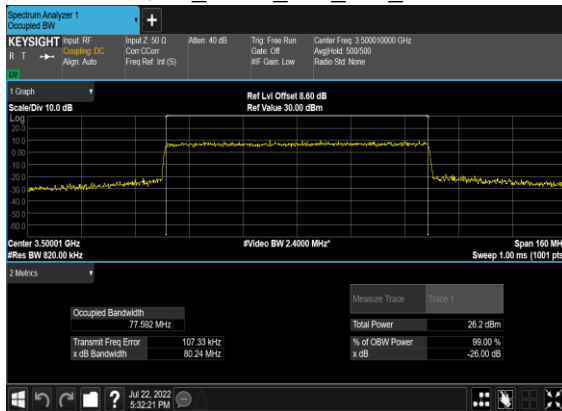

N77(80M)_CP-OFDM_256QAM_Outer_Full_Mid_CH

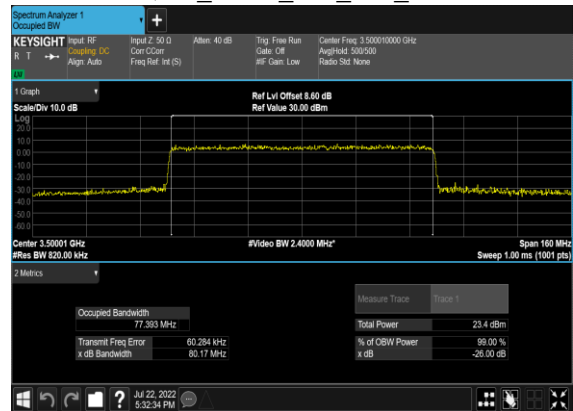

N77(90M)_DFT-s-OFDM_PI_2-BPSK_Outer_Full_Mid_CH

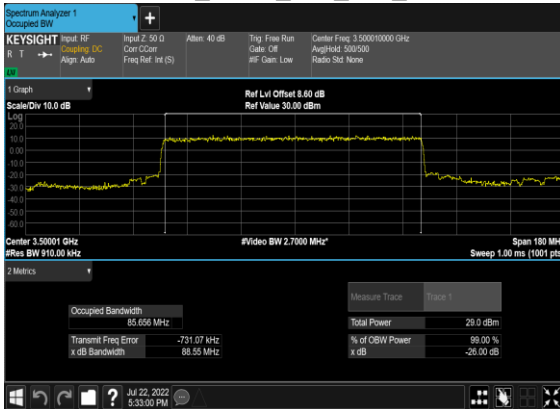

N77(90M)_DFT-s-OFDM_QPSK_Outer_Full_Mid_CH

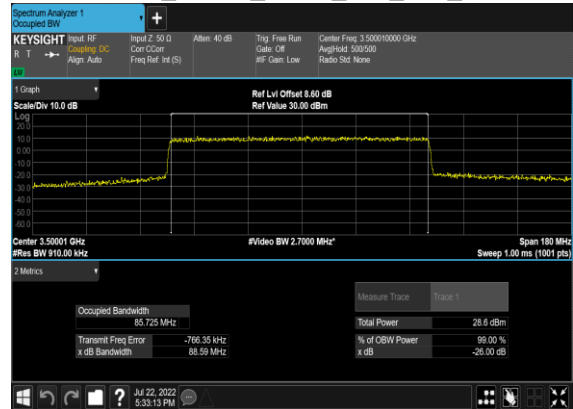

N77(90M)_CP-OFDM_QPSK_Outer_Full_Mid_CH

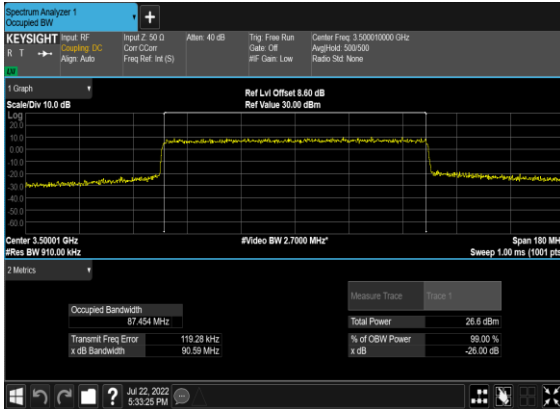

N77(90M)_CP-OFDM_16QAM_Outer_Full_Mid_CH

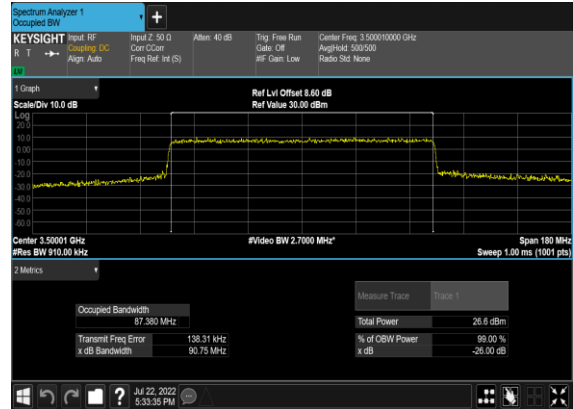

N77(90M)_CP-OFDM_64QAM_Outer_Full_Mid_CH

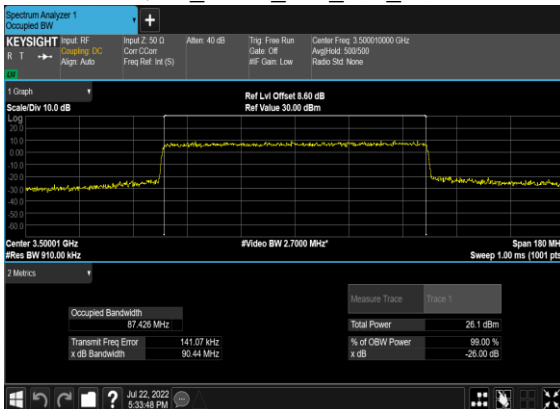

N77(90M)_CP-OFDM_256QAM_Outer_Full_Mid_CH

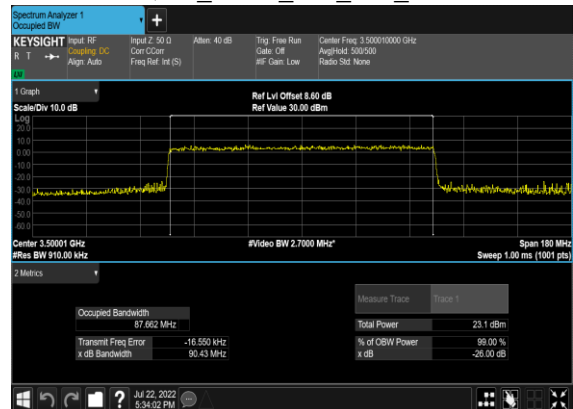

N77(100M)_DFT-s-OFDM_PI_2-
BPSK_Outer_Full_Mid_CH

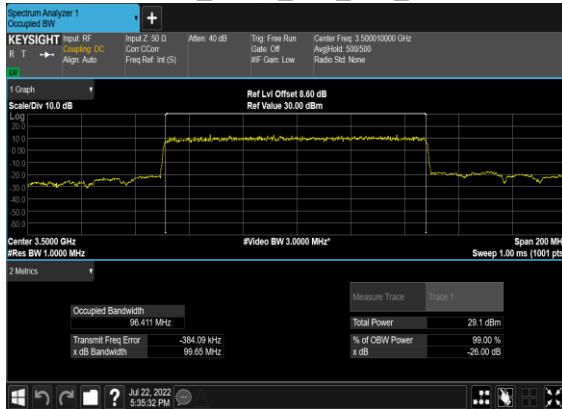

N77(100M)_DFT-s-
OFDM_QPSK_Outer_Full_Mid_CH

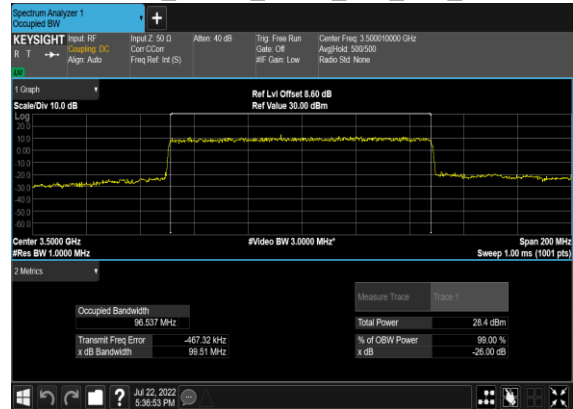

N77(100M)_CP-
OFDM_QPSK_Outer_Full_Mid_CH



N77(100M)_CP-OFDM_16
QAM_Outer_Full_Mid_CH

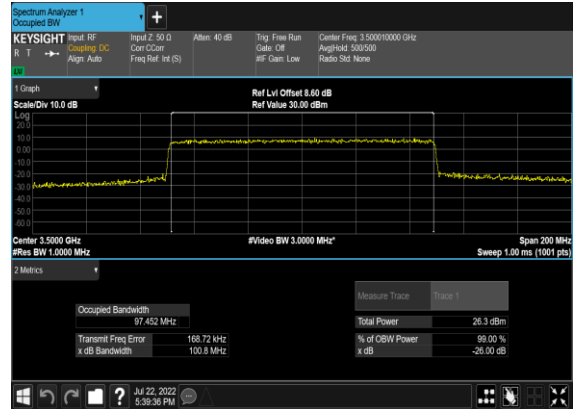

N77(100M)_CP-OFDM_64
QAM_Outer_Full_Mid_CH

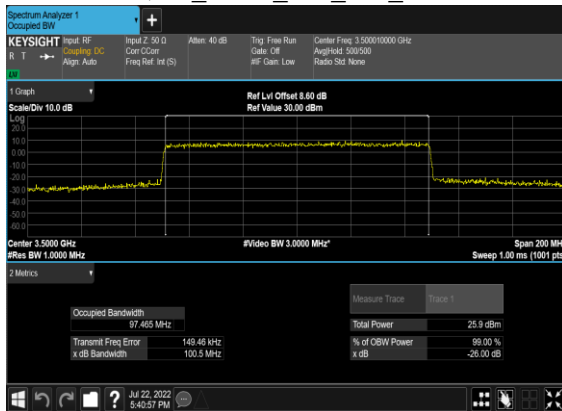

N77(100M)_CP-OFDM_256
QAM_Outer_Full_Mid_CH

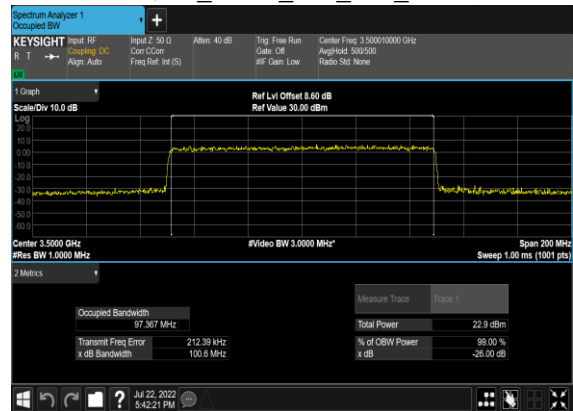

Conducted Spurious Emissions

NR Band	SCS (kHz)	Bandwidth (MHz)	Arfcn	Freq (MHz)	Modulation	RB	Result	Verdict
77	30	10	630334	3455.01	DFT-s-OFDM BPSK	1@0	see graph	---
77	30	10	630334	3455.01	DFT-s-OFDM BPSK	1@0	see graph	PASS
77	30	10	630334	3455.01	DFT-s-OFDM BPSK	1@0	see graph	PASS
77	30	10	630334	3455.01	DFT-s-OFDM QPSK	1@0	see graph	---
77	30	10	630334	3455.01	DFT-s-OFDM QPSK	1@0	see graph	PASS
77	30	10	630334	3455.01	DFT-s-OFDM QPSK	1@0	see graph	PASS
77	30	10	633334	3500.01	DFT-s-OFDM BPSK	1@0	see graph	---
77	30	10	633334	3500.01	DFT-s-OFDM BPSK	1@0	see graph	PASS
77	30	10	633334	3500.01	DFT-s-OFDM BPSK	1@0	see graph	PASS
77	30	10	633334	3500.01	DFT-s-OFDM QPSK	1@0	see graph	---
77	30	10	633334	3500.01	DFT-s-OFDM QPSK	1@0	see graph	PASS
77	30	10	633334	3500.01	DFT-s-OFDM QPSK	1@0	see graph	PASS
77	30	10	636332	3544.98	DFT-s-OFDM BPSK	1@0	see graph	---
77	30	10	636332	3544.98	DFT-s-OFDM BPSK	1@0	see graph	PASS
77	30	10	636332	3544.98	DFT-s-OFDM BPSK	1@0	see graph	PASS
77	30	10	636332	3544.98	DFT-s-OFDM QPSK	1@0	see graph	---
77	30	10	636332	3544.98	DFT-s-OFDM QPSK	1@0	see graph	PASS
77	30	10	636332	3544.98	DFT-s-OFDM QPSK	1@0	see graph	PASS
77	30	50	631668	3475.02	DFT-s-OFDM BPSK	1@0	see graph	---
77	30	50	631668	3475.02	DFT-s-OFDM BPSK	1@0	see graph	PASS
77	30	50	631668	3475.02	DFT-s-OFDM BPSK	1@0	see graph	PASS
77	30	50	631668	3475.02	DFT-s-OFDM QPSK	1@0	see graph	---

77	30	50	631668	3475.02	DFT-s-OFDM QPSK	1@0	see graph	PASS
77	30	50	631668	3475.02	DFT-s-OFDM QPSK	1@0	see graph	PASS
77	30	50	633334	3500.01	DFT-s-OFDM BPSK	1@0	see graph	---
77	30	50	633334	3500.01	DFT-s-OFDM BPSK	1@0	see graph	PASS
77	30	50	633334	3500.01	DFT-s-OFDM BPSK	1@0	see graph	PASS
77	30	50	633334	3500.01	DFT-s-OFDM QPSK	1@0	see graph	---
77	30	50	633334	3500.01	DFT-s-OFDM QPSK	1@0	see graph	PASS
77	30	50	633334	3500.01	DFT-s-OFDM QPSK	1@0	see graph	PASS
77	30	50	635000	3525.0	DFT-s-OFDM BPSK	1@0	see graph	---
77	30	50	635000	3525.0	DFT-s-OFDM BPSK	1@0	see graph	PASS
77	30	50	635000	3525.0	DFT-s-OFDM BPSK	1@0	see graph	PASS
77	30	50	635000	3525.0	DFT-s-OFDM QPSK	1@0	see graph	---
77	30	50	635000	3525.0	DFT-s-OFDM QPSK	1@0	see graph	PASS
77	30	50	635000	3525.0	DFT-s-OFDM QPSK	1@0	see graph	PASS
77	30	100	633334	3500.01	DFT-s-OFDM BPSK	1@0	see graph	---
77	30	100	633334	3500.01	DFT-s-OFDM BPSK	1@0	see graph	PASS
77	30	100	633334	3500.01	DFT-s-OFDM BPSK	1@0	see graph	PASS
77	30	100	633334	3500.01	DFT-s-OFDM QPSK	1@0	see graph	---
77	30	100	633334	3500.01	DFT-s-OFDM QPSK	1@0	see graph	PASS
77	30	100	633334	3500.01	DFT-s-OFDM QPSK	1@0	see graph	PASS

N77(10M)_DFT-s-OFDM_BPSK_Edge_1RB_Left_Low_CH



N77(10M)_DFT-s-OFDM_BPSK_Edge_1RB_Left_Low_CH

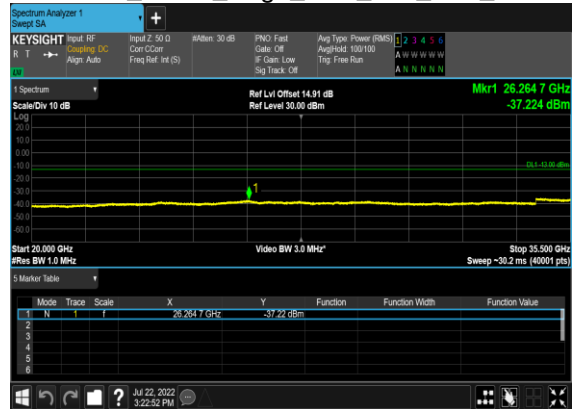

N77(10M)_DFT-s-OFDM_QPSK_Edge_1RB_Left_Low_CH

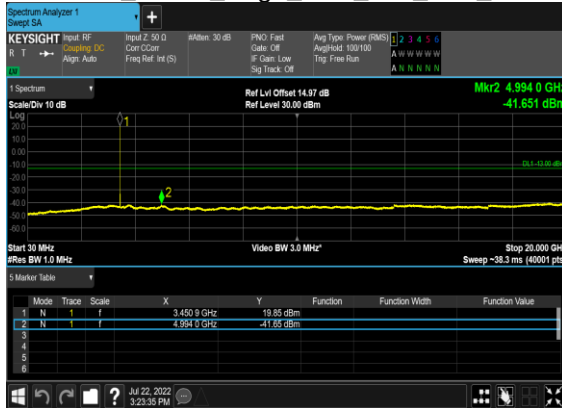

N77(10M)_DFT-s-OFDM_QPSK_Edge_1RB_Left_Low_CH



N77(10M)_DFT-s-OFDM_BPSK_Edge_1RB_Left_Mid_CH

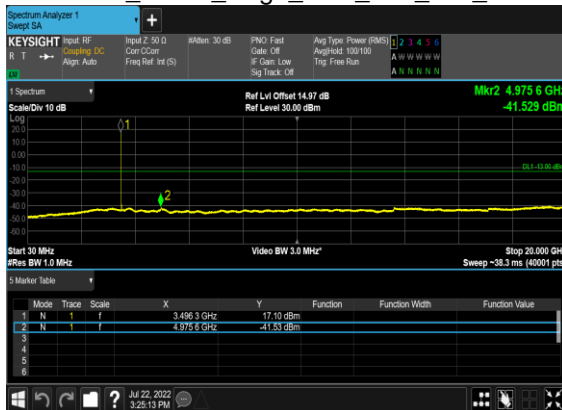

N77(10M)_DFT-s-OFDM_BPSK_Edge_1RB_Left_Mid_CH



N77(10M)_DFT-s-OFDM_QPSK_Edge_1RB_Left_Mid_CH



N77(10M)_DFT-s-OFDM_QPSK_Edge_1RB_Left_Mid_CH



N77(10M)_DFT-s-OFDM_BPSK_Edge_1RB_Left_High_CH

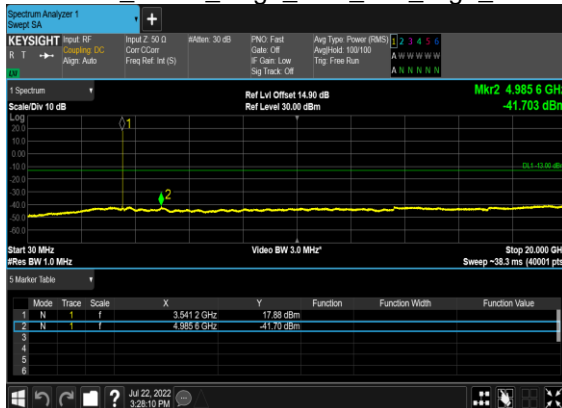

N77(10M)_DFT-s-OFDM_BPSK_Edge_1RB_Left_High_CH



N77(10M)_DFT-s-OFDM_QPSK_Edge_1RB_Left_High_CH

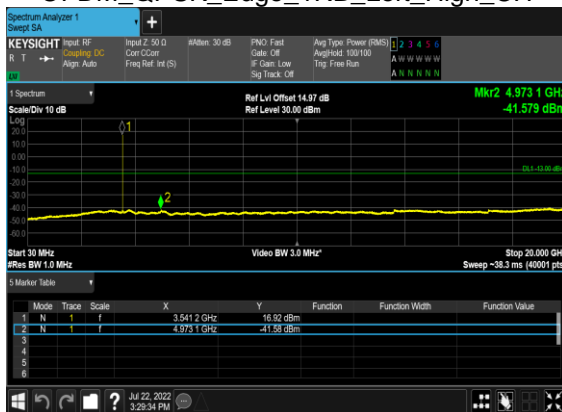

N77(10M)_DFT-s-OFDM_QPSK_Edge_1RB_Left_High_CH

