



FCC RADIO TEST REPORT

FCC ID : XHG-RG1000
Equipment : Mobile Hotspot
Model Name : RG1000
Applicant : Franklin Technology Inc.
906 JEI Platz, 186, Gasan digital 1-ro,
Gumcheon-Gu, Seoul, South Korea, 08502
Manufacturer : Franklin Technology Inc.
906 JEI Platz, 186, Gasan digital 1-ro,
Gumcheon-Gu, Seoul, South Korea, 08502
Standard : FCC 47 CFR Part 2, 22(H), 24(E), 27

The product was received on May 07, 2021 and testing was started from Jun. 15, 2021 and completed on Aug. 03, 2021. We, Sporton International Inc. EMC & Wireless Communications Laboratory, would like to declare that the tested sample has been evaluated in accordance with the test procedures given in ANSI / TIA-603-E and has been in compliance with the applicable technical standards.

The test results in this report apply exclusively to the tested model / sample. Without written approval of Sporton International Inc. EMC & Wireless Communications Laboratory, the test report shall not be reproduced except in full.

Louis Wu

Approved by: Louis Wu

Sporton International Inc. EMC & Wireless Communications Laboratory

No. 52, Huaya 1st Rd., Guishan Dist., Taoyuan City 333, Taiwan (R.O.C.)



Table of Contents

History of this test report.....	3
Summary of Test Result.....	4
1 General Description	5
1.1 Product Feature of Equipment Under Test.....	5
1.2 Modification of EUT	5
1.3 Testing Location	6
1.4 Applicable Standards.....	7
2 Test Configuration of Equipment Under Test	8
2.1 Test Mode.....	8
2.2 Connection Diagram of Test System.....	10
2.3 Support Unit used in test configuration and system	10
2.4 Measurement Results Explanation Example.....	10
2.5 Frequency List of Low/Middle/High Channels	11
3 Conducted Test Items.....	13
3.1 Measuring Instruments	13
3.2 Conducted Output Power and ERP/EIRP	14
3.3 Peak-to-Average Ratio	15
3.4 Occupied Bandwidth.....	16
3.5 Conducted Band Edge	17
3.6 Conducted Spurious Emission	19
3.7 Frequency Stability	20
4 Radiated Test Items	21
4.1 Measuring Instruments	21
4.2 Radiated Spurious Emission Measurement	23
5 List of Measuring Equipment.....	24
6 Uncertainty of Evaluation.....	26
Appendix A. Test Results of Conducted Test	
Appendix B. Test Results of Radiated Test	
Appendix C. Test Setup Photographs	



History of this test report

Report No.	Version	Description	Issued Date
FG140849C	01	Initial issue of report	Sep. 09, 2021



Summary of Test Result

Report Clause	Ref Std. Clause	Test Items	Result (PASS/FAIL)	Remark
3.2	§2.1046	Conducted Output Power	Reporting only	-
	§22.913 (a)(2)	Effective Radiated Power (n5)	Pass	
	§24.232 (c)	Equivalent Isotropic Radiated Power (n2)		
	§27.50 (d)(4)	Equivalent Isotropic Radiated Power (n66)		
	-	Equivalent Isotropic Radiated Power (n77) (n78)	Reporting only	
3.3	§24.232 (d) §27.50 (d)(5) 27.50 (j)(4)	Peak-to-Average Ratio	Pass	-
3.4	§2.1049	Occupied Bandwidth	Reporting only	-
3.5	§2.1051 §22.917 (a) §24.238 (a) §27.53 (h) §27.53 (l)(1)	Conducted Band Edge Measurement (n2) (n5) (n66) (n77) (n78)	Pass	-
3.6	§2.1051 §22.917 (a) §24.238 (a) §27.53 (h) §27.53 (l)(1)	Conducted Spurious Emission (n2) (n5) (n66) (n77) (n78)	Pass	-
3.7	§2.1055 §22.355 §24.235 §27.54	Frequency Stability Temperature & Voltage	Pass	-
4.2	§2.1053 §22.917 (a) §24.238 (a) §27.53 (h) §27.53 (l)(1)	Radiated Spurious Emission (n2) (n5) (n66) (n77) (n78)	Pass	Under limit 19.57 dB at 7482.000 MHz

Declaration of Conformity:

The test results with all measurement uncertainty excluded are presented in accordance with the regulation limits or requirements declared by manufacturers.

Comments and Explanations:

The declared of product specification for EUT presented in the report are provided by the manufacturer, and the manufacturer takes all the responsibilities for the accuracy of product specification.

Reviewed by: Avis Chuang

Report Producer: Celery Wei



1 General Description

1.1 Product Feature of Equipment Under Test

WCDMA/LTE/5G NR, Wi-Fi 2.4GHz 802.11b/g/n/ac/ax, and Wi-Fi 5GHz 802.11n/ac/ax.

Product Specification subjective to this standard	
Antenna Type	WWAN <Main>: PIFA Antenna <Aux.>: PIFA Antenna WLAN: <Chain 0>: PIFA Antenna <Chain 1>: PIFA Antenna
Antenna Gain	<Main> 5G NR n2: -1.54 dBi 5G NR n5: -1.07 dBi 5G NR n66: -1.58 dBi 5G NR n77: -1.85 dBi 5G NR n78: -1.85 dBi <Aux.>: 5G NR n2: -2.44 dBi 5G NR n66: -2.44 dBi

Remark: The above EUT's information was declared by manufacturer. Please refer to Comments and Explanations in report summary.

1.2 Modification of EUT

No modifications are made to the EUT during all test items.



1.3 Testing Location

Test Site	Sporton International Inc. EMC & Wireless Communications Laboratory
Test Site Location	No.52, Huaya 1st Rd., Guishan Dist., Taoyuan City 333, Taiwan (R.O.C.) TEL: +886-3-327-3456 FAX: +886-3-328-4978
Test Site No.	Sporton Site No.
	TH03-HY
Test Engineer	Luffy Lin
Temperature	24~26.5°C
Relative Humidity	49.8~55.5%

Test Site	Sporton International Inc. Wensan Laboratory
Test Site Location	No.58, Aly. 75, Ln. 564, Wenhua 3rd, Rd., Guishan Dist., Taoyuan City 333010, Taiwan (R.O.C.) TEL: +886-3-327-0868 FAX: +886-3-327-0855
Test Site No.	Sporton Site No.
	03CH20-HY (TAF Code: 3786)
Test Engineer	JC Liang
Temperature	20~23°C
Relative Humidity	60~70%
Remark	The Radiated Spurious Emission test item subcontracted to Sporton International Inc. Wensan Laboratory.

Note: The test site complies with ANSI C63.4 2014 requirement.

FCC Designation No.: TW1190 and TW3786



1.4 Applicable Standards

According to the specifications of the manufacturer, the EUT must comply with the requirements of the following standards:

- ♦ ANSI C63.26-2015
- ♦ ANSI / TIA-603-E
- ♦ FCC 47 CFR Part 2, 22(H), 24(E), 27
- ♦ FCC KDB 971168 D01 Power Meas. License Digital Systems v03r01
- ♦ FCC KDB 412172 D01 Determining ERP and EIRP v01r01
- ♦ FCC KDB 414788 D01 Radiated Test Site v01r01.

Remark:

1. All test items were verified and recorded according to the standards and without any deviation during the test.
2. This EUT has also been tested and complied with the requirements of FCC Part 15, Subpart B, recorded in a separate test report.
3. The TAF code is not including all the FCC KDB listed without accreditation.



2 Test Configuration of Equipment Under Test

2.1 Test Mode

Antenna port conducted and radiated test items listed below are performed according to KDB 971168 D01 Power Meas. License Digital Systems v03r01 with maximum output power.

The measured emission level of the EUT was maximized by rotating the EUT on a turntable, adjusting the orientation of the EUT and EUT antenna in three orthogonal axis (X: flat, Y: portrait, Z: landscape), and adjusting the measurement antenna orientation, following C63.26 exploratory test procedures and find (Y Plane) as worst plane.

Test Items	NR Band	Bandwidth (MHz)											Modulation					RB #			Test Channel		
		5	10	15	20	30	40	50	60	80	90	100	PI/2 BPSK	QPSK	16QAM	64QAM	256QAM	1	Half	Full	L	M	H
Max. Output Power	n2	v	v	v	v	-	-	-	-	-	-	-	v	v	v	v	v	v	v	v	v	v	v
	n5	v	v	v	v	-	-	-	-	-	-	-	v	v	v	v	v	v	v	v	v	v	v
	n66	v	v	v	v	v	v	-	-	-	-	-	v	v	v	v	v	v	v	v	v	v	v
	n77	-	-	-	v		v	v	v	v	v	v	v	v	v	v	v	v	v	v	v	v	v
	n78	-	-	-	v		v	v	v	v	v	v	v	v	v	v	v	v	v	v	v	v	v
Peak-to-Average Ratio	n2				v	-	-	-	-	-	-	-	v	v	v	v	v			v			v
	n5				v	-	-	-	-	-	-	-	v	v	v	v	v			v			v
	n66				v								v	v	v	v	v			v			v
	n77	-	-	-	v								v	v	v	v	v			v			v
	n78	covered by n77																					
26dB and 99% Bandwidth	n2	v	v	v	v	-	-	-	-	-	-	-	v	v	v	v	v			v			v
	n5	v	v	v	v	-	-	-	-	-	-	-	v	v	v	v	v			v			v
	n66	v	v	v	v	v	v	-	-	-	-	-	v	v	v	v	v			v			v
	n77	-	-	-	v		v	v	v	v	v	v	v	v	v	v	v			v			v
	n78	covered by n77																					
Conducted Band Edge	n2	v	v	v	v	-	-	-	-	-	-	-	v	v	v	v	v	v		v	v		v
	n5	v	v	v	v	-	-	-	-	-	-	-	v	v	v	v	v	v		v	v		v
	n66	v	v	v	v	v	v	-	-	-	-	-	v	v	v	v	v	v		v	v		v
	n77	-	-	-	v		v	v	v	v	v	v	v	v	v	v	v	v		v	v		v
	n78	covered by n77																					



Test Items	NR Band	Bandwidth (MHz)											Modulation					RB #			Test Channel			
		5	10	15	20	30	40	50	60	80	90	100	PI/2 BPSK	QPSK	16QAM	64QAM	256QAM	1	Half	Full	L	M	H	
Conducted Spurious Emission	n2	v				-	-	-	-	-	-	-		v				v			v	v	v	
	n5	v				-	-	-	-	-	-	-		v				v			v	v	v	
	n66	v						-	-	-	-	-		v				v			v	v	v	
	n77	-	-	-	v									v				v			v	v	v	
	n78	covered by n77																						
Frequency Stability	n2				v	-	-	-	-	-	-	-		v						v		v		
	n5				v	-	-	-	-	-	-	-		v						v		v		
	n66				v			-	-	-	-	-		v						v		v		
	n77	-	-	-	v									v						v		v		
	n78	covered by n77																						
E.R.P / E.I.R.P	n2	v	v	v	v		-	-	-	-	-	-		v	v	v	v	v		Max Power				
	n5	v	v	v	v		-	-	-	-	-	-		v	v	v	v	v						
	n66	v	v	v	v	v	v	-	-	-	-	-		v	v	v	v	v						
	n77	-	-	-	v		v	v	v	v	v	v		v	v	v	v	v						
	n78	-	-	-	v		v	v	v	v	v	v		v	v	v	v	v						
Radiated Spurious Emission	n2	Worst Case																			v	v	v	
	n5	Worst Case																			v	v	v	
	n66	Worst Case																			v	v	v	
	n77	Worst Case																			v	v	v	
	n78	covered by n77																						
Remark	<ol style="list-style-type: none"> The mark "v" means that this configuration is chosen for testing The mark "-" means that this bandwidth is not supported. The device is investigated from 30MHz to 10 times of fundamental signal for radiated spurious emission test under different RB size/offset and modulations in exploratory test. Subsequently, only the worst case emissions are reported. Test combination is EN-DC 5A-n2A, EN-DC 13A-n2A, EN-DC 66A-n2A, EN-DC 2A-n5A, EN-DC 48A-n5A, EN-DC 66A-n5A, EN-DC 2A-n66A, EN-DC 5A-n66A, EN-DC 13A-n66A, EN-DC 2A-n77A, and EN-DC 66A-n77A. For radiated measurement, pre-scanned in two modes, DFT-s OFDM and CP OFDM. The worst cases (DFT-s OFDM) were recorded in this report. Wider operating range bandwidth covers narrower one when the power is higher or the same. 																							

2.2 Connection Diagram of Test System

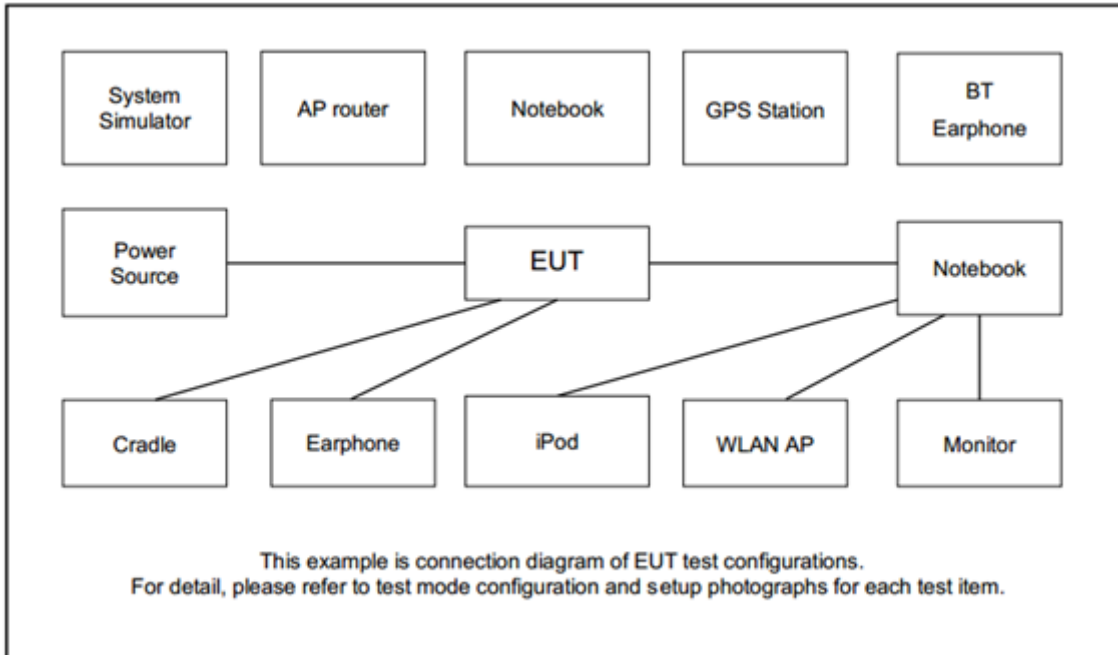

2.3 Support Unit used in test configuration and system

Item	Equipment	Brand Name	Model No.	FCC ID	Data Cable	Power Cord
1.	System Simulator	Anritsu	MT8821C	N/A	N/A	Unshielded, 1.8 m
2.	5G Wireless Test Platform	Keysight	MT8000A	N/A	N/A	Unshielded, 1.8m

2.4 Measurement Results Explanation Example

For all conducted test items:

The offset level is set in the spectrum analyzer to compensate the RF cable loss and attenuator factor between EUT conducted output port and spectrum analyzer. With the offset compensation, the spectrum analyzer reading level is exactly the EUT RF output level.

The spectrum analyzer offset is derived from RF cable loss and attenuator factor.

Offset = RF cable loss + attenuator factor.

Following shows an offset computation example with cable loss 4.2 dB and 10dB attenuator.

Example :

$$\begin{aligned} \text{Offset(dB)} &= \text{RF cable loss(dB)} + \text{attenuator factor(dB)} \\ &= 4.2 + 10 = 14.2 \text{ (dB)} \end{aligned}$$



2.5 Frequency List of Low/Middle/High Channels

5G NR Band n2 Channel and Frequency List				
BW [MHz]	Channel/Frequency(MHz)	Lowest	Middle	Highest
20	Channel	372000	376000	380000
	Frequency	1860	1880	1900
15	Channel	371500	376000	380500
	Frequency	1857.5	1880	1902.5
10	Channel	371000	376000	381000
	Frequency	1855	1880	1905
5	Channel	370500	376000	381500
	Frequency	1852.5	1880	1907.5

5G NR Band n5 Channel and Frequency List				
BW [MHz]	Channel/Frequency(MHz)	Lowest	Middle	Highest
20	Channel	166800	167300	167800
	Frequency	834	836.5	839
15	Channel	166300	167300	168300
	Frequency	831.5	836.5	841.5
10	Channel	165800	167300	168800
	Frequency	829	836.5	844
5	Channel	165300	167300	169300
	Frequency	826.5	836.5	846.5

5G NR Band n66 Channel and Frequency List				
BW [MHz]	Channel/Frequency(MHz)	Lowest	Middle	Highest
40	Channel	345000	346500	348000
	Frequency	1725	1732.5	1740
30	Channel	344500	346500	348500
	Frequency	1722.5	1732.5	1742.5
20	Channel	344000	346500	349000
	Frequency	1720	1732.5	1745
15	Channel	343500	346500	349500
	Frequency	1717.5	1732.5	1747.5
10	Channel	343000	346500	350000
	Frequency	1715	1732.5	1750
5	Channel	342500	346500	350500
	Frequency	1712.5	1732.5	1752.5



5G NR Band n77 Channel and Frequency List				
BW [MHz]	Channel/Frequency(MHz)	Lowest	Middle	Highest
100	Channel	650000	656000	662000
	Frequency	3750	3840	3930
90	Channel	649668	656000	662332
	Frequency	3745.02	3840	3934.98
80	Channel	649334	656000	662666
	Frequency	3740.01	3840	3939.99
60	Channel	648668	656000	663332
	Frequency	3730.02	3840	3949.98
50	Channel	648334	656000	663666
	Frequency	3725.01	3840	3954.99
40	Channel	648000	656000	664000
	Frequency	3720	3840	3960
20	Channel	647334	656000	664666
	Frequency	3710.01	3840	3969.99

5G NR n78 Channel and Frequency List				
BW [MHz]	Channel/Frequency(MHz)	Lowest	Middle	Highest
100	Channel	-	650000	-
	Frequency	-	3750	-
90	Channel	649668	650000	650332
	Frequency	3745.02	3750	3754.98
80	Channel	649334	650000	650666
	Frequency	3740.01	3750	3759.99
60	Channel	648668	650000	651332
	Frequency	3730.02	3750	3769.98
50	Channel	648334	650000	651666
	Frequency	3725.01	3750	3774.99
40	Channel	648000	650000	652000
	Frequency	3720	3750	3780
20	Channel	647334	650000	652666
	Frequency	3710.01	3750	3789.99

3 Conducted Test Items

3.1 Measuring Instruments

See list of measuring instruments of this test report.

3.1.1 Test Setup

3.1.2 Conducted Output Power

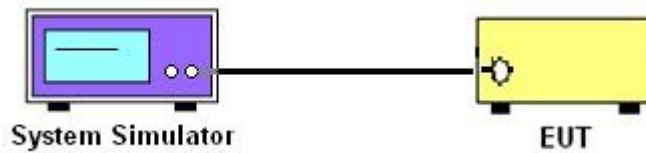

3.1.3 Peak-to-Average Ratio, Occupied Bandwidth ,Conducted Band-Edge and Conducted Spurious Emission

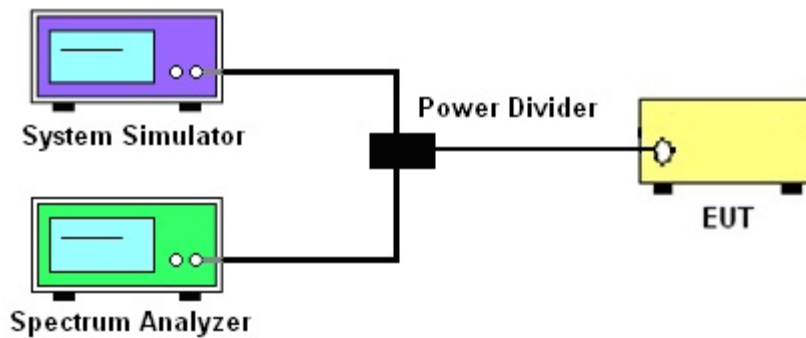

3.1.4 Frequency Stability

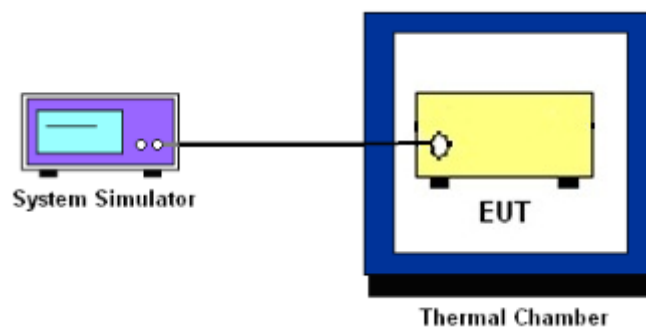

3.1.5 Test Result of Conducted Test

Please refer to Appendix A.



3.2 Conducted Output Power and ERP/EIRP

3.2.1 Description of the Conducted Output Power Measurement and ERP/EIRP Measurement

A system simulator was used to establish communication with the EUT. Its parameters were set to force the EUT transmitting at maximum output power. The measured power in the radio frequency on the transmitter output terminals shall be reported.

The ERP of mobile transmitters must not exceed 7 Watts for 5G NR n5

The EIRP of mobile transmitters must not exceed 2 Watts for 5G NR n2

The EIRP of mobile transmitters must not exceed 1 Watts for 5G NR n66

According to KDB 412172 D01 Power Approach,

$EIRP = P_T + G_T - L_C$, $ERP = EIRP - 2.15$, where

P_T = transmitter output power in dBm

G_T = gain of the transmitting antenna in dBi

L_C = signal attenuation in the connecting cable between the transmitter and antenna in dB

For n77, n78

27.53(j)(2)

(2) The power of each fixed or base station transmitting in the 3700-3980 MHz band and situated in any geographic location other than that described in paragraph (j)(1) of this section is limited to an EIRP of 1640 Watts/MHz. This limit applies to the aggregate power of all antenna elements in any given sector of a base station.

3.2.2 Test Procedures

1. The transmitter output port was connected to the system simulator.
2. Set EUT at maximum power through the system simulator.
3. Select lowest, middle, and highest channels for each band and different modulation.
4. Measure and record the power level from the system simulator.



3.3 Peak-to-Average Ratio

3.3.1 Description of the PAR Measurement

Power Complementary Cumulative Distribution Function (CCDF) curves provide a means for characterizing the power peaks of a digitally modulated signal on a statistical basis. A CCDF curve depicts the probability of the peak signal amplitude exceeding the average power level. Most contemporary measurement instrumentation include the capability to produce CCDF curves for an input signal provided that the instrument's resolution bandwidth can be set wide enough to accommodate the entire input signal bandwidth. In measuring transmissions in this band using an average power technique, the peak-to-average ratio (PAR) of the transmission may not exceed 13 dB.

3.3.2 Test Procedures

The testing follows ANSI C63.26-2015 Section 5.2.6

1. The EUT was connected to spectrum and system simulator via a power divider.
2. Set the CCDF (Complementary Cumulative Distribution Function) option in spectrum analyzer.
3. The highest RF powers were measured and recorded the maximum PAPR level associated with a probability of 0.1 %.
4. Record the deviation as Peak to Average Ratio.



3.4 Occupied Bandwidth

3.4.1 Description of Occupied Bandwidth Measurement

The occupied bandwidth is the width of a frequency band such that, below the lower and above the upper frequency limits, the mean powers emitted are each equal to a specified percentage 0.5% of the total mean transmitted power.

The 26 dB emission bandwidth is defined as the frequency range between two points, one above and one below the carrier frequency, at which the spectral density of the emission is attenuated 26 dB below the maximum in-band spectral density of the modulated signal. Spectral density (power per unit bandwidth) is to be measured with a detector of resolution bandwidth equal to approximately 1.0% of the emission bandwidth.

3.4.2 Test Procedures

The testing follows ANSI C63.26-2015 Section 5.4.3 (26dB) and Section 5.4.4 (99OB)

1. The EUT was connected to spectrum analyzer and system simulator via a power divider.
2. The spectrum analyzer center frequency is set to the nominal EUT channel center frequency. The span range for the spectrum analyzer shall be between two and five times the anticipated OBW.
3. The nominal resolution bandwidth (RBW) shall be in the range of 1 to 5 % of the anticipated OBW, and the VBW shall be at least 3 times the RBW.
4. Set the detection mode to peak, and the trace mode to max hold.
5. Determine the reference value: Set the EUT to transmit a modulated signal. Allow the trace to stabilize. Set the spectrum analyzer marker to the highest level of the displayed trace.
(this is the reference value)
6. Determine the “-26 dB down amplitude” as equal to (Reference Value – X).
7. Place two markers, one at the lowest and the other at the highest frequency of the envelope of the spectral display such that each marker is at or slightly below the “-X dB down amplitude” determined in step 6. If a marker is below this “-X dB down amplitude” value it shall be placed as close as possible to this value. The OBW is the positive frequency difference between the two markers.
8. Use the 99 % power bandwidth function of the spectrum analyzer and report the measured bandwidth.



3.5 Conducted Band Edge

3.5.1 Description of Conducted Band Edge Measurement

22.917(a)

For operations in the 824 – 849 MHz band, the FCC limit is $43 + 10\log_{10}(P[\text{Watts}])$ dB below the transmitter power $P(\text{Watts})$ in a 100kHz bandwidth. However, in the 1MHz bands immediately outside and adjacent to the licensee's frequency block, a resolution bandwidth of at least one percent of the emission bandwidth of the fundamental emission of the transmitter may be employed.

24.238 (a)

For operations in the 1850-1910 and 1930-1990 MHz band, the FCC limit is $43 + 10\log_{10}(P[\text{Watts}])$ dB below the transmitter power $P(\text{Watts})$ in a 1MHz bandwidth. However, in the 1 MHz bands immediately outside and adjacent to the frequency block a resolution bandwidth of at least one percent of the emission bandwidth of the fundamental emission of the transmitter may be employed.

27.53 (h)

For operations in the 1710 – 1755 MHz band, 1755-1780 MHz, the FCC limit is $43 + 10\log_{10}(P[\text{Watts}])$ dB below the transmitter power $P(\text{Watts})$ in a 1 MHz bandwidth. However, in the 1MHz bands immediately outside and adjacent to the licensee's frequency block, a resolution bandwidth of at least one percent of the emission bandwidth of the fundamental emission of the transmitter may be employed.

27.53 (l)(2)

For mobile operations in the 3700-3980 MHz band, the conducted power of any emission outside the licensee's authorized bandwidth shall not exceed -13 dBm/MHz. Compliance with this paragraph (l)(2) is based on the use of measurement instrumentation employing a resolution bandwidth of 1 megahertz or greater. However, in the 1 megahertz bands immediately outside and adjacent to the licensee's frequency block, the minimum resolution bandwidth for the measurement shall be either one percent of the emission bandwidth of the fundamental emission of the transmitter or 350 kHz. In the bands between 1 and 5 MHz removed from the licensee's frequency block, the minimum resolution bandwidth for the measurement shall be 500 kHz. The emission bandwidth is defined as the width of the signal between two points, one below the carrier center frequency and one above the carrier center frequency, outside of which all emissions are attenuated at least 26 dB below the transmitter power.



3.5.2 Test Procedures

The testing follows FCC KDB 971168 D01 v03r01 Section 6.1.

1. The EUT was connected to spectrum analyzer and system simulator via a power divider.
2. The band edges of low and high channels for the highest RF powers were measured.
3. Set RBW \geq 1% EBW in the 1MHz band immediately outside and adjacent to the band edge.
4. Beyond the 1 MHz band from the band edge, RBW=1MHz was used.
5. Set spectrum analyzer with RMS detector.
6. The RF fundamental frequency should be excluded against the limit line in the operating frequency band.
7. Checked that all the results comply with the emission limit line.

The limit line is derived from $43 + 10\log(P)$ dB below the transmitter power P(Watts)



3.6 Conducted Spurious Emission

3.6.1 Description of Conducted Spurious Emission Measurement

The power of any emission outside of the authorized operating frequency ranges must be lower than the transmitter power (P) by a factor of at least $43 + 10 \log (P)$ dB.

3.6.2 Test Procedures

The testing follows FCC KDB 971168 D01 v03r01 Section 6.1.

1. The EUT was connected to spectrum analyzer and system simulator via a power divider.
2. The RF output of EUT was connected to the spectrum analyzer by RF cable and attenuator. The path loss was compensated to the results for each measurement.
3. The middle channel for the highest RF power within the transmitting frequency was measured.
4. The conducted spurious emission for the whole frequency range was taken.
5. Make the measurement with the spectrum analyzer's RBW = 1MHz, VBW = 3MHz.
6. Set spectrum analyzer with RMS detector.
7. Taking the record of maximum spurious emission.
8. The RF fundamental frequency should be excluded against the limit line in the operating frequency band.
9. The limit line is derived from $43 + 10\log(P)$ dB below the transmitter power P(Watts)



3.7 Frequency Stability

3.7.1 Description of Frequency Stability Measurement

22.355

The frequency stability shall be measured by variation of ambient temperature and variation of primary supply voltage to ensure that the fundamental emission stays within the authorized frequency block. The frequency stability of the transmitter shall be maintained within $\pm 0.00025\%$ ($\pm 2.5\text{ppm}$) of the center frequency.

24.235 & 27.54

The frequency stability shall be sufficient to ensure that the fundamental emission stays within the authorized frequency block.

3.7.2 Test Procedures for Temperature Variation

The testing follows FCC KDB 971168 D01 v03r01 Section 9.0.

1. The EUT was set up in the thermal chamber and connected with the system simulator.
2. With power OFF, the temperature was decreased to -30°C and the EUT was stabilized before testing. Power was applied and the maximum change in frequency was recorded within one minute.
3. With power OFF, the temperature was raised in 10°C step up to 50°C . The EUT was stabilized at each step for at least half an hour. Power was applied and the maximum frequency change was recorded within one minute.

3.7.3 Test Procedures for Voltage Variation

The testing follows FCC KDB 971168 D01 v03r01 Section 9.0.

1. The EUT was placed in a temperature chamber at $20\pm 5^{\circ}\text{C}$ and connected with the system simulator.
2. The power supply voltage to the EUT was varied from 85% to 115% of the nominal value measured at the input to the EUT.
3. The variation in frequency was measured for the worst case.

4 Radiated Test Items

4.1 Measuring Instruments

See list of measuring instruments of this test report.

4.1.1 Test Setup

For radiated emissions below 30MHz

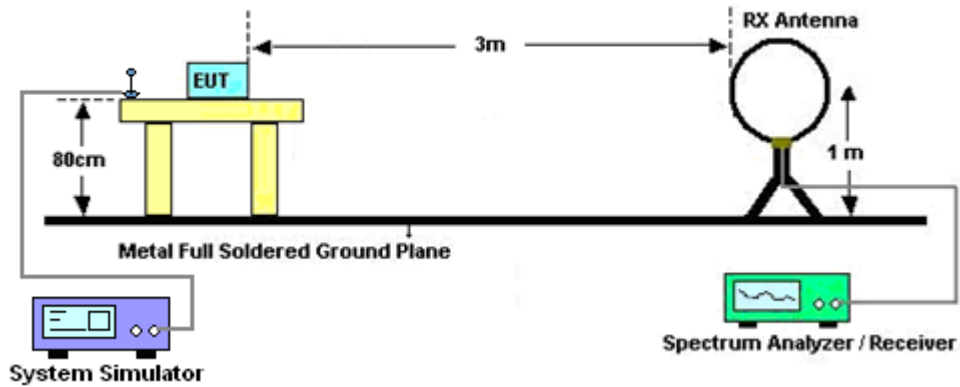

For radiated test from 30MHz to 1GHz

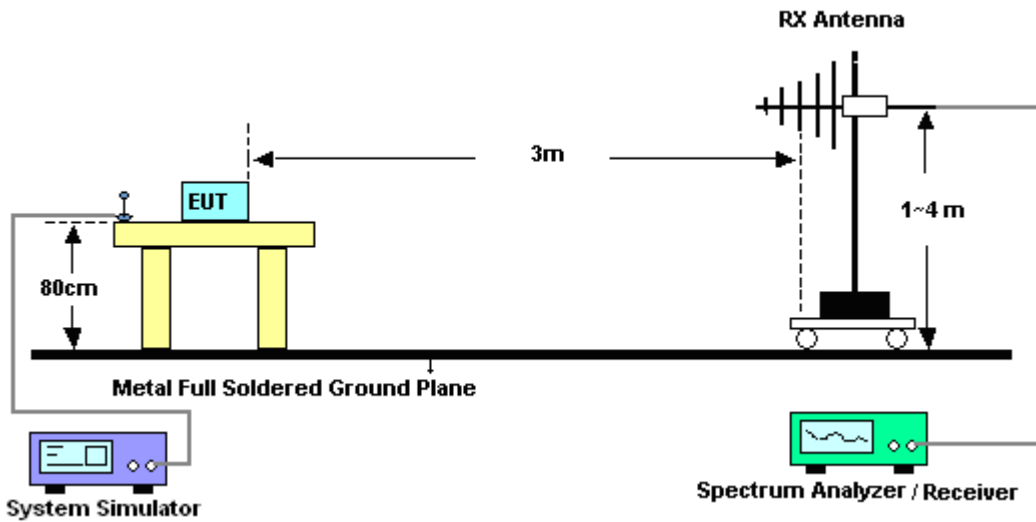

For radiated test from 1GHz to 18GHz

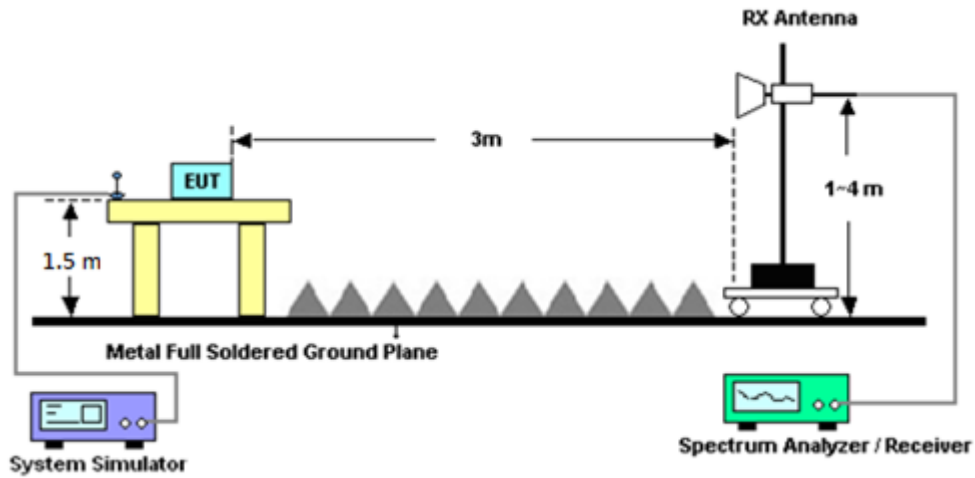

For radiated emissions above 18GHz

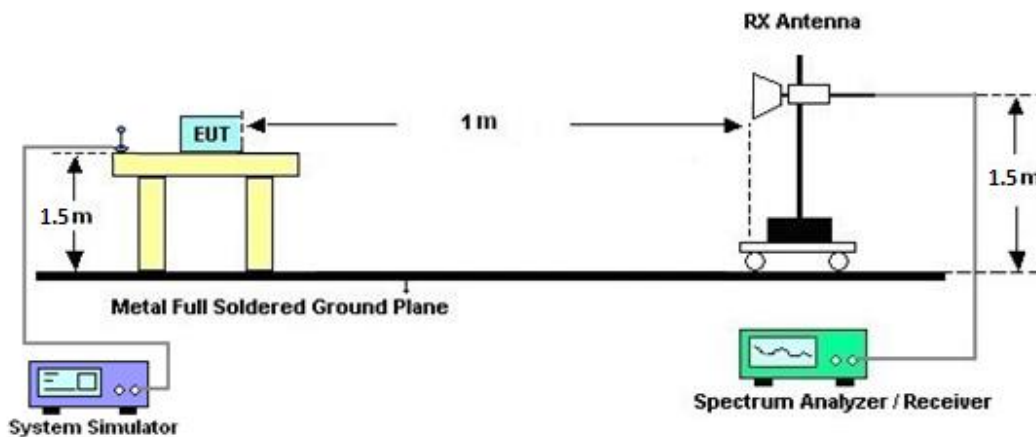

4.1.2 Test Result of Radiated Test

Please refer to Appendix B.

Note:

The low frequency, which started from 9 kHz to 30MHz, was pre-scanned and the result which was 20dB lower than the limit line was not reported.

There is a comparison data of both open-field test site and alternative test site - semi-Anechoic chamber according to 414788 D01 Radiated Test Site v01r01, and the result came out very similar.



4.2 Radiated Spurious Emission Measurement

4.2.1 Description of Radiated Spurious Emission Measurement

The radiated spurious emission was measured by substitution method according to ANSI / TIA-603-E. The power of any emission outside of the authorized operating frequency ranges must be attenuated below the transmitter power (P) by a factor of at least $43 + 10 \log (P)$ dB. The spectrum is scanned from 30 MHz up to a frequency including its 10th harmonic.

4.2.2 Test Procedures

The testing follows FCC KDB 971168 D01 v03r01 Section 7 and ANSI / TIA-603-E Section 2.2.12.

1. The EUT was placed on a turntable with 0.8 meter for frequency below 1GHz and 1.5 meter for frequency above 1GHz respectively above ground.
2. The EUT was set 3 meters from the receiving antenna, which was mounted on the antenna tower.
3. The table was rotated 360 degrees to determine the position of the highest spurious emission.
4. The height of the receiving antenna is varied between one meter and four meters to search the maximum spurious emission for both horizontal and vertical polarizations.
5. Make the measurement with the spectrum analyzer's RBW = 1MHz, VBW = 3MHz, taking the record of maximum spurious emission.
6. A horn antenna was substituted in place of the EUT and was driven by a signal generator.
7. Tune the output power of signal generator to the same emission level with EUT maximum spurious emission.
8. Taking the record of output power at antenna port.
9. Repeat step 7 to step 8 for another polarization.
10. The RF fundamental frequency should be excluded against the limit line in the operating frequency band.

The limit line is derived from $43 + 10\log(P)$ dB below the transmitter power P(Watts)

$EIRP \text{ (dBm)} = S.G. \text{ Power} - Tx \text{ Cable Loss} + Tx \text{ Antenna Gain}$

$ERP \text{ (dBm)} = EIRP - 2.15$



5 List of Measuring Equipment

Instrument	Brand Name	Model No.	Serial No.	Characteristics	Calibration Date	Test Date	Due Date	Remark
Spectrum Analyzer	Keysight	N9010A	MY54200486	10Hz~44GHz	Oct. 23, 2020	Jun. 22, 2021~ Jul. 01, 2021	Oct. 22, 2021	Radiation (03CH20-HY)
EMI Test Receiver	Keysight	N9038A	MY59053012	N/A	Nov. 18, 2020	Jun. 22, 2021~ Jul. 01, 2021	Nov. 17, 2021	Radiation (03CH20-HY)
Loop Antenna	Rohde & Schwarz	HFH2-Z2	100488	9 kHz~30 MHz	Jul. 14, 2020	Jun. 22, 2021~ Jul. 01, 2021	Jul. 13, 2021	Radiation (03CH20-HY)
Bilog Antenna	TESEQ	CBL 6111D & N-6-06	35414 & AT-N0602	30MHz~1GHz	Oct. 11, 2020	Jun. 22, 2021~ Jul. 01, 2021	Oct. 10, 2021	Radiation (03CH20-HY)
Bilog Antenna	TESEQ	CBL 6111D&00802 N1D01N-06	55606 & 08	30MHz~1GHz	Oct. 22, 2020	Jun. 22, 2021~ Jul. 01, 2021	Oct. 21, 2021	Radiation (03CH20-HY)
Horn Antenna	SCHWARZBE CK	BBHA 9120 D	002360	1GHz-18GHz	Nov. 03, 2020	Jun. 22, 2021~ Jul. 01, 2021	Nov. 02, 2021	Radiation (03CH20-HY)
Horn Antenna	SCHWARZBE CK	BBHA 9120 D	9120D-1328	1GHz~18GHz	Nov. 23, 2020	Jun. 22, 2021~ Jul. 01, 2021	Nov. 22, 2021	Radiation (03CH20-HY)
SHF-EHF Horn Antenna	SCHWARZBE CK	BBHA 9170	00993	18GHz~40GHz	Nov. 19, 2020	Jun. 22, 2021~ Jul. 01, 2021	Nov. 18, 2021	Radiation (03CH20-HY)
SHF-EHF Horn Antenna	SCHWARZBE CK	BBHA 9170	BBHA917057 6	18GHz~40GHz	May 21, 2021	Jun. 22, 2021~ Jul. 01, 2021	May 20, 2022	Radiation (03CH20-HY)
Preamplifier	COM-POWER	PAM-103	18020201	1MHz-1000MHz	Jan. 04, 2021	Jun. 22, 2021~ Jul. 01, 2021	Jan. 03, 2022	Radiation (03CH20-HY)
Amplifier	EMCI	EMC118A45S E	980792	N/A	Nov. 16, 2020	Jun. 22, 2021~ Jul. 01, 2021	Nov. 15, 2021	Radiation (03CH20-HY)
Preamplifier	EMEC	EM18G40G	060715	18GHz~40GHz	Dec. 11, 2020	Jun. 22, 2021~ Jul. 01, 2021	Dec. 10, 2021	Radiation (03CH20-HY)
Filter	Wainwright	WLK4-1000-15 30-8000-40SS	SN27	1.53GHz Low Pass Filter	May 25, 2021	Jun. 22, 2021~ Jul. 01, 2021	May 24, 2022	Radiation (03CH20-HY)
Filter	Wainwright	WHKX8-6090- 7000-18000-4 0SS	SN99	N/A	Nov. 05, 2020	Jun. 22, 2021~ Jul. 01, 2021	Nov. 04, 2021	Radiation (03CH20-HY)
Filter	Wainwright	WHKX12-2700 -3000-18000-6 0ST	SN8	N/A	Mar. 26, 2021	Jun. 22, 2021~ Jul. 01, 2021	Mar. 25, 2022	Radiation (03CH20-HY)
Hygrometer	TECPEL	DTM-303B	TP200728	N/A	Mar. 09, 2021	Jun. 22, 2021~ Jul. 01, 2021	Mar. 08, 2022	Radiation (03CH20-HY)
RF Cable	HUBER + SUHNER	SUCOFLEX 102	519229/2,80 4015/2,8040 27/2	N/A	Jan. 20, 2021	Jun. 22, 2021~ Jul. 01, 2021	Jan. 19, 2022	Radiation (03CH20-HY)
Software	Audix	E3 6.2009-8-24	RK-002156	N/A	N/A	Jun. 22, 2021~ Jul. 01, 2021	N/A	Radiation (03CH20-HY)
Controller	EMEC	EM1000	N/A	Control Turn table & Ant Mast	N/A	Jun. 22, 2021~ Jul. 01, 2021	N/A	Radiation (03CH20-HY)
Antenna Mast	EMEC	AM-BS-4500-B	N/A	1m~4m	N/A	Jun. 22, 2021~ Jul. 01, 2021	N/A	Radiation (03CH20-HY)
Turn Table	EMEC	TT2000	N/A	0~360 Degree	N/A	Jun. 22, 2021~ Jul. 01, 2021	N/A	Radiation (03CH20-HY)
Signal Generator	Rohde & Schwarz	SMF100A	101107	100kHz~40GHz	Dec. 04, 2020	Jun. 22, 2021~ Jul. 01, 2021	Dec. 03, 2021	Radiation (03CH20-HY)



Instrument	Brand Name	Model No.	Serial No.	Characteristics	Calibration Date	Test Date	Due Date	Remark
Programmable Power Supply	GW Instek	PSS-2005	EL890001	50Hz~60Hz	Oct. 05, 2020	Jun. 15, 2021~ Aug. 03, 2021	Oct. 04, 2021	Conducted (TH03-HY)
Signal Analyzer	Rohde & Schwarz	FSV3044	101048	10Hz~44GHz	Apr. 20, 2021	Jun. 15, 2021~ Aug. 03, 2021	Apr. 19, 2022	Conducted (TH03-HY)
Temperature Chamber	ESPEC	SU-241	92003713	-30℃ ~95℃	May 21, 2021	Jun. 15, 2021~ Aug. 03, 2021	May 20, 2022	Conducted (TH03-HY)
Hygrometer	Testo	608-H11	3489324	NA	Jan. 18, 2021	Jun. 15, 2021~ Aug. 03, 2021	Jan. 17, 2022	Conducted (TH03-HY)
Base Station (Measure)	Anritsu	MT8821C	6261849015	LTE	Sep. 18, 2020	Jun. 15, 2021~ Aug. 03, 2021	Sep. 17, 2021	Conducted (TH03-HY)
Base Station (Measure)	Anritsu	MT8000A	6261940327	FR1	Sep. 23, 2020	Jun. 15, 2021~ Aug. 03, 2021	Sep. 22, 2021	Conducted (TH03-HY)



6 Uncertainty of Evaluation

Uncertainty of Radiated Emission Measurement (30 MHz ~ 1000 MHz)

Measuring Uncertainty for a Level of Confidence of 95% ($U = 2Uc(y)$)	3.31 dB
---	---------

Uncertainty of Radiated Emission Measurement (1 GHz ~ 18 GHz)

Measuring Uncertainty for a Level of Confidence of 95% ($U = 2Uc(y)$)	3.63 dB
---	---------

Uncertainty of Radiated Emission Measurement (18 GHz ~ 40 GHz)

Measuring Uncertainty for a Level of Confidence of 95% ($U = 2Uc(y)$)	4.03 dB
---	---------



Appendix A. Test Results of Conducted Test

Conducted Output Power(Average power) and ERP/EIRP

NR n2 Maximum Average Power [dBm] (GT - LC = -1.54 dB)								
BW [MHz]	RB Size	RB Offset	Mod	Lowest	Middle	Highest	EIRP (dBm)	EIRP(W)
5	1	1	PI/2 BPSK	21.67	21.55	21.15	20.18	0.1042
5	1	23		21.69	21.41	21.22		
5	12	6		21.72	21.65	21.32		
5	1	0		21.15	21.04	20.70		
5	1	24		21.13	20.96	20.57		
5	25	0		21.13	21.12	20.98		
5	1	1	QPSK	21.53	21.38	21.49		
5	1	23		21.55	21.30	21.44		
5	12	6		21.61	21.46	21.51		
5	1	0		20.51	20.44	20.31		
5	1	24		20.48	20.26	20.37		
5	25	0		20.54	20.46	20.46		
5	1	1	16-QAM	20.63	20.64	20.60	19.10	0.0813
5	1	1	64-QAM	19.00	19.07	18.83		
5	1	1	256-QAM	16.72	16.99	16.69		
Limit	EIRP < 2W			Result			Pass	

NR n2 Maximum Average Power [dBm] (GT - LC = -1.54 dB)								
BW [MHz]	RB Size	RB Offset	Mod	Lowest	Middle	Highest	EIRP (dBm)	EIRP(W)
10	1	1	PI/2 BPSK	21.74	21.97	21.69	20.43	0.1104
10	1	50		21.83	21.69	21.64		
10	25	12		21.91	21.94	21.78		
10	1	0		21.44	21.49	20.79		
10	1	51		21.38	21.19	21.05		
10	50	0		21.28	21.41	21.33		
10	1	1	QPSK	21.48	21.85	21.58		
10	1	50		21.47	21.65	21.57		
10	25	12		21.81	21.91	21.76		
10	1	0		20.63	20.92	20.70		
10	1	51		20.67	20.64	20.63		
10	50	0		20.73	20.85	20.67		
10	1	1	16-QAM	20.79	21.03	20.84	19.49	0.0889
10	1	1	64-QAM	19.15	19.44	19.05		
10	1	1	256-QAM	16.84	16.93	16.87		
Limit	EIRP < 2W			Result			Pass	



NR n2 Maximum Average Power [dBm] (GT - LC = -1.54 dB)								
BW [MHz]	RB Size	RB Offset	Mod	Lowest	Middle	Highest	EIRP (dBm)	EIRP(W)
15	1	1	PI/2 BPSK	22.04	22.21	21.91	20.67	0.1167
15	1	77		22.16	21.92	21.76		
15	36	18		22.01	22.02	21.81		
15	1	0		21.50	21.66	21.36		
15	1	78		21.65	21.38	21.21		
15	75	0		21.58	21.57	21.35		
15	1	1	QPSK	21.92	22.05	21.79		
15	1	77		22.13	21.78	21.83		
15	36	18		21.92	22.00	21.82		
15	1	0		20.85	21.07	20.81		
15	1	78		21.04	20.84	20.68		
15	75	0		20.99	21.07	20.86		
15	1	1	16-QAM	21.09	21.26	20.92	19.72	0.0938
15	1	1	64-QAM	19.46	19.49	19.34		
15	1	1	256-QAM	17.15	17.43	17.13		
Limit	EIRP < 2W			Result			Pass	

NR n2 Maximum Average Power [dBm] (GT - LC = -1.54 dB)								
BW [MHz]	RB Size	RB Offset	Mod	Lowest	Middle	Highest	EIRP (dBm)	EIRP(W)
20	1	1	PI/2 BPSK	21.87	22.19	21.80	20.65	0.1161
20	1	104		22.13	21.90	21.59		
20	50	25		22.05	22.07	21.85		
20	1	0		21.44	21.79	20.59		
20	1	105		21.73	21.40	20.67		
20	100	0		21.57	21.45	21.27		
20	1	1	QPSK	21.81	21.96	21.82		
20	1	104		22.12	21.77	21.52		
20	50	25		22.03	21.98	21.78		
20	1	0		21.05	21.08	20.79		
20	1	105		21.25	20.83	20.51		
20	100	0		21.15	20.97	20.74		
20	1	1	16-QAM	21.13	21.30	20.96	19.76	0.0946
20	1	1	64-QAM	19.28	19.52	19.18		
20	1	1	256-QAM	17.14	17.33	16.99		
Limit	EIRP < 2W			Result			Pass	



NR n5 Maximum Average Power [dBm] (GT - LC = -1.07 dB)										
BW [MHz]	RB Size	RB Offset	Mod	Lowest	Middle	Highest	ERP (dBm)	ERP(W)		
5	1	1	PI/2 BPSK	21.59	21.56	21.59	18.41	0.0693		
5	1	23		21.42	21.55	21.46				
5	12	6		21.56	21.63	21.62				
5	1	0		21.02	21.05	21.05				
5	1	24		18.82	21.00	20.94				
5	25	0		21.01	21.04	21.06				
5	1	1	QPSK	21.53	21.50	21.49			17.48	0.0560
5	1	23		21.29	21.50	21.39				
5	12	6		21.54	21.49	21.59				
5	1	0		20.51	20.42	20.52				
5	1	24		20.39	20.51	20.40				
5	25	0		20.56	20.53	20.55				
5	1	1	16-QAM	20.70	20.49	20.69	17.48	0.0560		
5	1	1	64-QAM	18.90	19.21	19.04				
5	1	1	256-QAM	16.72	16.62	16.72				
Limit	ERP < 7W			Result			Pass			

NR n5 Maximum Average Power [dBm] (GT - LC = -1.07 dB)										
BW [MHz]	RB Size	RB Offset	Mod	Lowest	Middle	Highest	ERP (dBm)	ERP(W)		
10	1	1	PI/2 BPSK	21.45	21.40	21.54	18.43	0.0697		
10	1	50		21.47	21.59	21.51				
10	25	12		21.59	21.65	21.61				
10	1	0		20.95	20.88	21.06				
10	1	51		20.89	20.05	20.96				
10	50	0		20.99	21.07	21.08				
10	1	1	QPSK	21.41	21.24	21.47			17.40	0.0550
10	1	50		21.30	21.54	21.44				
10	25	12		21.56	21.58	21.57				
10	1	0		20.38	20.27	20.45				
10	1	51		20.36	20.54	20.45				
10	50	0		20.49	20.49	20.58				
10	1	1	16-QAM	20.47	20.41	20.62	17.40	0.0550		
10	1	1	64-QAM	18.75	18.78	18.89				
10	1	1	256-QAM	16.54	16.49	16.61				
Limit	ERP < 7W			Result			Pass			



NR n5 Maximum Average Power [dBm] (GT - LC = -1.07 dB)										
BW [MHz]	RB Size	RB Offset	Mod	Lowest	Middle	Highest	ERP (dBm)	ERP(W)		
15	1	1	PI/2 BPSK	21.48	21.54	21.48	18.40	0.0692		
15	1	77		21.56	21.62	21.46				
15	36	18		21.44	21.58	21.53				
15	1	0		20.91	20.89	20.93				
15	1	78		21.03	21.03	20.85				
15	75	0		21.04	21.08	20.98				
15	1	1	QPSK	21.51	21.47	21.38			17.47	0.0558
15	1	77		21.54	21.56	21.37				
15	36	18		21.44	21.55	21.48				
15	1	0		20.43	20.45	20.41				
15	1	78		20.48	20.50	20.36				
15	75	0		20.57	20.56	20.49				
15	1	1	16-QAM	20.69	20.35	20.61	17.47	0.0558		
15	1	1	64-QAM	18.84	19.05	18.77				
15	1	1	256-QAM	16.63	16.61	16.60				
Limit	ERP < 7W			Result			Pass			

NR n5 Maximum Average Power [dBm] (GT - LC = -1.07 dB)										
BW [MHz]	RB Size	RB Offset	Mod	Lowest	Middle	Highest	ERP (dBm)	ERP(W)		
20	1	1	PI/2 BPSK	21.46	21.32	21.35	18.44	0.0698		
20	1	104		21.52	21.38	21.39				
20	50	25		21.58	21.57	21.66				
20	1	0		21.01	21.45	20.82				
20	1	105		20.94	20.98	20.87				
20	100	0		21.04	21.01	20.97				
20	1	1	QPSK	21.38	21.29	21.25			17.39	0.0548
20	1	104		21.46	21.39	21.32				
20	50	25		21.55	21.56	21.50				
20	1	0		20.39	20.33	20.28				
20	1	105		20.54	20.38	20.31				
20	100	0		20.53	20.55	20.48				
20	1	1	16-QAM	20.61	20.43	20.51	17.39	0.0548		
20	1	1	64-QAM	18.72	18.80	18.64				
20	1	1	256-QAM	16.55	16.28	16.48				
Limit	ERP < 7W			Result			Pass			



NR n66 Maximum Average Power [dBm] (GT - LC = -1.58 dB)										
BW [MHz]	RB Size	RB Offset	Mod	Lowest	Middle	Highest	EIRP (dBm)	EIRP(W)		
5	1	1	PI/2 BPSK	22.22	22.09	22.35	20.77	0.1194		
5	1	23		22.25	22.13	22.35				
5	12	6		22.21	22.14	22.34				
5	1	0		21.74	21.56	21.82				
5	1	24		21.69	21.65	21.83				
5	25	0		21.70	21.56	21.82				
5	1	1	QPSK	22.12	21.97	22.24			20.77	0.1194
5	1	23		22.14	22.03	22.26				
5	12	6		22.24	22.11	22.19				
5	1	0		21.13	21.01	21.29				
5	1	24		21.08	21.05	21.30				
5	25	0		21.24	21.14	21.40				
5	1	1	16-QAM	21.18	20.92	21.20	19.62	0.0916		
5	1	1	64-QAM	19.62	19.57	19.83				
5	1	1	256-QAM	17.13	17.03	17.28				
Limit	EIRP < 1W			Result			Pass			

NR n66 Maximum Average Power [dBm] (GT - LC = -1.58 dB)										
BW [MHz]	RB Size	RB Offset	Mod	Lowest	Middle	Highest	EIRP (dBm)	EIRP(W)		
10	1	1	PI/2 BPSK	22.33	22.07	22.44	20.86	0.1219		
10	1	50		22.24	22.22	22.37				
10	25	12		22.27	21.59	22.43				
10	1	0		21.85	21.61	22.01				
10	1	51		21.68	21.75	21.88				
10	50	0		21.75	21.58	21.92				
10	1	1	QPSK	22.24	22.01	22.37			20.86	0.1219
10	1	50		22.12	22.17	22.28				
10	25	12		22.32	22.16	22.41				
10	1	0		21.25	21.03	21.39				
10	1	51		21.12	21.14	22.37				
10	50	0		21.26	21.11	21.38				
10	1	1	16-QAM	21.13	21.03	21.36	19.78	0.0951		
10	1	1	64-QAM	19.82	19.43	19.80				
10	1	1	256-QAM	17.25	17.01	17.34				
Limit	EIRP < 1W			Result			Pass			



NR n66 Maximum Average Power [dBm] (GT - LC = -1.58 dB)								
BW [MHz]	RB Size	RB Offset	Mod	Lowest	Middle	Highest	EIRP (dBm)	EIRP(W)
15	1	1	PI/2 BPSK	22.40	22.21	22.43	20.85	0.1216
15	1	77		22.17	21.17	22.13		
15	36	18		22.19	22.06	22.22		
15	1	0		21.99	21.61	21.90		
15	1	78		21.61	21.59	21.61		
15	75	0		21.75	21.53	21.62		
15	1	1	QPSK	22.36	22.03	22.32		
15	1	77		22.06	22.07	22.09		
15	36	18		22.28	22.07	22.21		
15	1	0		21.36	21.03	21.31		
15	1	78		21.02	21.00	21.04		
15	75	0		21.24	21.09	21.25		
15	1	1	16-QAM	21.41	20.93	21.34	19.83	0.0962
15	1	1	64-QAM	19.85	19.69	19.78		
15	1	1	256-QAM	17.38	17.07	17.34		
Limit	EIRP < 1W			Result			Pass	

NR n66 Maximum Average Power [dBm] (GT - LC = -1.58 dB)								
BW [MHz]	RB Size	RB Offset	Mod	Lowest	Middle	Highest	EIRP (dBm)	EIRP(W)
20	1	1	PI/2 BPSK	22.31	22.08	22.32	20.74	0.1186
20	1	104		22.01	22.19	22.20		
20	50	25		22.17	22.03	22.24		
20	1	0		21.85	21.62	21.83		
20	1	105		21.53	21.68	21.71		
20	100	0		21.59	21.50	21.66		
20	1	1	QPSK	22.26	21.97	22.21		
20	1	104		21.92	21.99	22.13		
20	50	25		22.18	22.04	22.26		
20	1	0		21.23	20.99	21.22		
20	1	105		20.93	20.99	21.14		
20	100	0		21.15	21.03	21.22		
20	1	1	16-QAM	21.25	21.02	21.22	19.67	0.0927
20	1	1	64-QAM	19.68	19.40	19.61		
20	1	1	256-QAM	17.22	16.93	17.17		
Limit	EIRP < 1W			Result			Pass	



NR n66 Maximum Average Power [dBm] (GT - LC = -1.58 dB)										
BW [MHz]	RB Size	RB Offset	Mod	Lowest	Middle	Highest	EIRP (dBm)	EIRP(W)		
30	1	1	PI/2 BPSK	22.25	21.19	22.25	20.78	0.1197		
30	1	158		22.15	22.34	22.36				
30	80	40		22.13	22.11	22.27				
30	1	0		21.76	21.73	21.71				
30	1	159		21.74	21.85	21.92				
30	160	0		21.60	21.58	21.73				
30	1	1	QPSK	22.07	22.06	22.15			20.78	0.1197
30	1	158		22.03	22.16	22.23				
30	80	40		22.15	22.09	22.25				
30	1	0		21.08	21.07	21.07				
30	1	159		21.04	21.17	21.28				
30	160	0		21.15	21.08	21.29				
30	1	1	16-QAM	21.06	21.05	21.19	19.61	0.0914		
30	1	1	64-QAM	19.61	19.65	19.63				
30	1	1	256-QAM	17.07	17.18	17.16				
Limit	EIRP < 1W			Result			Pass			

NR n66 Maximum Average Power [dBm] (GT - LC = -1.58 dB)										
BW [MHz]	RB Size	RB Offset	Mod	Lowest	Middle	Highest	EIRP (dBm)	EIRP(W)		
40	1	1	PI/2 BPSK	21.96	22.08	22.16	20.80	0.1202		
40	1	214		21.95	22.25	22.38				
40	108	54		22.06	22.13	22.19				
40	1	0		21.49	21.56	21.72				
40	1	215		21.52	21.77	21.93				
40	216	0		21.46	21.57	21.61				
40	1	1	QPSK	21.85	21.99	22.00			20.80	0.1202
40	1	214		21.90	22.09	22.25				
40	108	54		22.09	22.11	22.18				
40	1	0		20.89	21.03	21.03				
40	1	215		20.88	21.15	21.29				
40	216	0		21.05	21.10	21.19				
40	1	1	16-QAM	20.96	20.88	21.09	19.51	0.0893		
40	1	1	64-QAM	19.44	19.56	19.48				
40	1	1	256-QAM	17.13	17.18	16.98				
Limit	EIRP < 1W			Result			Pass			



NR n77 (HPUE) Maximum Average Power [dBm] (GT - LC = -1.85 dB)								
BW [MHz]	RB Size	RB Offset	Mod	Lowest	Middle	Highest	EIRP (dBm)	EIRP(W)
20	1	1	PI/2 BPSK	25.96	25.91	25.77	24.12	0.2582
20	1	49		25.88	25.94	25.81		
20	25	12		25.92	25.87	25.79		
20	1	0		22.62	22.63	22.32		
20	1	50		22.37	22.62	22.31		
20	50	0		25.51	25.59	25.35		
20	1	1	QPSK	25.97	25.96	25.74	23.42	0.2198
20	1	49		25.80	25.97	25.76		
20	25	12		25.95	25.88	25.82		
20	1	0		22.51	22.61	22.26		
20	1	50		22.31	22.66	22.24		
20	50	0		24.99	25.13	24.84		
20	1	1	16-QAM	25.27	25.26	24.91	23.42	0.2198
20	1	1	64-QAM	23.20	23.27	22.96		
20	1	1	256-QAM	21.24	21.26	21.20		
Limit	EIRP < 1W			Result			Pass	



NR n77 (HPUE) Maximum Average Power [dBm] (GT - LC = -1.85 dB)								
BW [MHz]	RB Size	RB Offset	Mod	Lowest	Middle	Highest	EIRP (dBm)	EIRP(W)
40	1	1	PI/2 BPSK	25.88	25.79	25.49	24.13	0.2588
40	1	104		25.98	25.88	25.78		
40	50	25		25.92	25.81	25.79		
40	1	0		22.95	22.85	22.02		
40	1	105		22.98	23.01	22.33		
40	100	0		25.81	25.86	25.26		
40	1	1	QPSK	25.78	25.73	25.44		
40	1	104		25.94	25.77	25.71		
40	50	25		25.74	25.79	25.89		
40	1	0		22.70	22.76	21.95		
40	1	105		22.45	22.88	22.27		
40	100	0		25.14	25.37	24.76		
40	1	1	16-QAM	25.33	25.43	24.98	23.58	0.2280
40	1	1	64-QAM	23.38	23.42	23.48		
40	1	1	256-QAM	21.55	21.56	21.26		
Limit	EIRP < 1W			Result			Pass	



NR n77 (HPUE) Maximum Average Power [dBm] (GT - LC = -1.85 dB)										
BW [MHz]	RB Size	RB Offset	Mod	Lowest	Middle	Highest	EIRP (dBm)	EIRP(W)		
50	1	1	PI/2 BPSK	25.93	25.86	25.79	24.08	0.2559		
50	1	131		25.75	25.86	25.76				
50	64	32		25.83	25.77	25.84				
50	1	0		22.47	22.42	22.31				
50	1	132		22.26	22.62	22.32				
50	128	0		25.34	25.49	25.13				
50	1	1	QPSK	25.93	25.86	25.73			24.08	0.2559
50	1	131		25.74	25.85	25.74				
50	64	32		25.88	25.78	25.86				
50	1	0		22.46	22.33	22.24				
50	1	132		22.26	22.63	22.25				
50	128	0		24.84	25.02	24.85				
50	1	1	16-QAM	25.18	24.95	25.16	23.33	0.2153		
50	1	1	64-QAM	23.16	23.03	23.17				
50	1	1	256-QAM	21.13	21.07	21.22				
Limit	EIRP < 1W			Result			Pass			

NR n77 (HPUE) Maximum Average Power [dBm] (GT - LC = -1.85 dB)										
BW [MHz]	RB Size	RB Offset	Mod	Lowest	Middle	Highest	EIRP (dBm)	EIRP(W)		
60	1	1	PI/2 BPSK	25.63	25.61	25.55	23.86	0.2432		
60	1	160		25.42	25.71	25.49				
60	81	40		25.38	25.70	25.58				
60	1	0		22.06	22.11	22.08				
60	1	161		21.93	22.16	22.06				
60	162	0		24.96	25.23	25.18				
60	1	1	QPSK	25.59	25.55	25.51			23.86	0.2432
60	1	160		25.40	25.65	25.63				
60	81	40		25.38	25.71	25.46				
60	1	0		21.98	22.08	22.11				
60	1	161		21.93	22.15	22.23				
60	162	0		24.51	24.69	24.53				
60	1	1	16-QAM	24.78	24.65	24.75	22.93	0.1963		
60	1	1	64-QAM	22.62	23.04	23.11				
60	1	1	256-QAM	20.75	20.82	20.93				
Limit	EIRP < 1W			Result			Pass			



NR n77 (HPUE) Maximum Average Power [dBm] (GT - LC = -1.85 dB)								
BW [MHz]	RB Size	RB Offset	Mod	Lowest	Middle	Highest	EIRP (dBm)	EIRP(W)
80	1	1	PI/2 BPSK	25.66	25.57	25.64	23.89	0.2449
80	1	215		25.25	25.55	25.57		
80	108	54		25.03	25.12	25.72		
80	1	0		22.21	22.02	22.17		
80	1	216		21.85	22.06	22.07		
80	216	0		24.97	25.29	25.21		
80	1	1	QPSK	25.61	25.47	25.55	23.00	0.1995
80	1	215		25.17	25.49	25.53		
80	108	54		25.43	25.74	25.71		
80	1	0		22.09	21.98	22.11		
80	1	216		21.71	22.01	21.99		
80	216	0		24.47	24.72	24.70		
80	1	1	16-QAM	24.56	24.71	24.85	23.00	0.1995
80	1	1	64-QAM	22.76	22.72	22.78		
80	1	1	256-QAM	20.83	20.74	20.76		
Limit	EIRP < 1W			Result			Pass	



NR n77 (HPUE) Maximum Average Power [dBm] (GT - LC = -1.85 dB)								
BW [MHz]	RB Size	RB Offset	Mod	Lowest	Middle	Highest	EIRP (dBm)	EIRP(W)
90	1	1	PI/2 BPSK	25.72	25.38	25.61	23.87	0.2438
90	1	243		25.46	25.53	25.57		
90	120	60		25.54	25.64	25.58		
90	1	0		22.21	21.91	22.07		
90	1	244		21.89	22.03	22.06		
90	243	0		25.01	25.16	25.05		
90	1	1	QPSK	25.21	25.38	25.41		
90	1	243		25.17	25.11	25.62		
90	120	60		25.58	25.54	25.55		
90	1	0		21.95	21.85	22.09		
90	1	244		22.01	22.04	22.06		
90	243	0		24.55	24.65	24.53		
90	1	1	16-QAM	24.32	24.42	24.81	22.96	0.1977
90	1	1	64-QAM	23.01	22.88	22.82		
90	1	1	256-QAM	20.57	20.66	20.74		
Limit	EIRP < 1W			Result			Pass	

NR n77 (HPUE) Maximum Average Power [dBm] (GT - LC = -1.85 dB)								
BW [MHz]	RB Size	RB Offset	Mod	Lowest	Middle	Highest	EIRP (dBm)	EIRP(W)
100	1	1	PI/2 BPSK	25.59	25.51	25.46	23.84	0.2421
100	1	271		25.14	25.48	25.36		
100	135	67		25.48	25.58	25.55		
100	1	0		22.16	21.78	22.04		
100	1	272		21.97	22.02	22.12		
100	270	0		24.94	25.08	25.01		
100	1	1	QPSK	25.59	25.22	25.26		
100	1	271		25.46	25.53	25.46		
100	135	67		25.42	25.69	25.55		
100	1	0		22.12	21.74	21.88		
100	1	272		22.00	22.01	21.97		
100	270	0		24.44	24.59	24.43		
100	1	1	16-QAM	24.79	24.32	24.38	22.94	0.1968
100	1	1	64-QAM	22.85	22.76	22.32		
100	1	1	256-QAM	20.78	20.46	20.36		
Limit	EIRP < 1W			Result			Pass	



NR n78 Maximum Average Power [dBm] (GT - LC = -1.85 dB)								
BW [MHz]	RB Size	RB Offset	Mod	Lowest	Middle	Highest	EIRP (dBm)	EIRP(W)
20	1	1	PI/2 BPSK	23.69	22.52	23.30	21.84	0.1528
20	1	49		23.43	23.47	23.40		
20	25	12		23.59	23.39	23.28		
20	1	0		23.32	23.02	22.88		
20	1	50		23.09	23.10	22.96		
20	50	0		23.16	23.04	22.91		
20	1	1	QPSK	23.67	23.33	23.31	20.96	0.1247
20	1	49		23.33	23.37	23.28		
20	25	12		23.57	23.37	23.27		
20	1	0		22.74	22.46	22.33		
20	1	50		22.42	22.44	22.44		
20	50	0		22.70	22.51	22.44		
20	1	1	16-QAM	22.81	22.74	22.61	20.96	0.1247
20	1	1	64-QAM	20.96	20.64	20.53		
20	1	1	256-QAM	18.89	18.64	18.57		
Limit	EIRP < 1W			Result			Pass	



NR n78 Maximum Average Power [dBm] (GT - LC = -1.85 dB)								
BW [MHz]	RB Size	RB Offset	Mod	Lowest	Middle	Highest	EIRP (dBm)	EIRP(W)
40	1	1	PI/2 BPSK	23.89	23.62	23.65	22.04	0.1600
40	1	104		23.45	23.68	23.57		
40	50	25		23.51	23.57	23.44		
40	1	0		23.47	23.24	23.29		
40	1	105		23.08	23.28	23.15		
40	100	0		23.17	23.21	23.07		
40	1	1	QPSK	23.85	23.58	23.57	21.44	0.1393
40	1	104		23.43	23.59	23.55		
40	50	25		23.52	23.61	23.45		
40	1	0		23.01	22.69	22.71		
40	1	105		21.67	22.74	22.65		
40	100	0		21.63	22.71	22.63		
40	1	1	16-QAM	23.29	22.74	22.76	21.44	0.1393
40	1	1	64-QAM	21.07	20.88	21.31		
40	1	1	256-QAM	21.16	18.95	18.98		
Limit	EIRP < 1W			Result			Pass	



NR n78 Maximum Average Power [dBm] (GT - LC = -1.85 dB)										
BW [MHz]	RB Size	RB Offset	Mod	Lowest	Middle	Highest	EIRP (dBm)	EIRP(W)		
50	1	1	PI/2 BPSK	23.69	23.43	23.45	21.84	0.1528		
50	1	131		23.32	23.31	23.35				
50	64	32		23.38	23.42	23.36				
50	1	0		23.30	23.12	23.08				
50	1	132		22.95	22.91	22.92				
50	128	0		23.03	23.01	22.93				
50	1	1	QPSK	23.62	23.39	23.42			20.963	0.1248
50	1	131		23.29	23.28	23.31				
50	64	32		23.39	23.41	23.31				
50	1	0		22.71	22.51	22.53				
50	1	132		22.40	22.39	22.42				
50	128	0		22.55	22.53	22.44				
50	1	1	16-QAM	22.81	22.65	22.79	20.963	0.1248		
50	1	1	64-QAM	20.93	20.68	22.67				
50	1	1	256-QAM	18.99	18.71	18.75				
Limit	EIRP < 1W			Result			Pass			

NR n78 Maximum Average Power [dBm] (GT - LC = -1.85 dB)										
BW [MHz]	RB Size	RB Offset	Mod	Lowest	Middle	Highest	EIRP (dBm)	EIRP(W)		
60	1	1	PI/2 BPSK	23.24	23.05	22.98	21.39	0.1377		
60	1	160		23.01	22.92	23.01				
60	81	40		23.01	23.09	23.02				
60	1	0		22.86	22.67	22.60				
60	1	161		22.61	22.52	22.59				
60	162	0		22.62	22.64	22.63				
60	1	1	QPSK	23.18	23.01	22.92			20.62	0.1153
60	1	160		22.92	22.87	22.93				
60	81	40		22.98	23.08	22.98				
60	1	0		22.26	22.12	22.01				
60	1	161		22.06	21.98	22.02				
60	162	0		22.14	22.12	22.11				
60	1	1	16-QAM	22.47	22.31	22.12	20.62	0.1153		
60	1	1	64-QAM	20.46	20.31	20.55				
60	1	1	256-QAM	18.64	18.54	18.23				
Limit	EIRP < 1W			Result			Pass			



NR n78 Maximum Average Power [dBm] (GT - LC = -1.85 dB)								
BW [MHz]	RB Size	RB Offset	Mod	Lowest	Middle	Highest	EIRP (dBm)	EIRP(W)
80	1	1	PI/2 BPSK	23.31	23.21	23.10	21.46	0.1400
80	1	215		22.90	22.93	23.07		
80	108	54		23.02	23.08	23.12		
80	1	0		22.88	22.81	22.75		
80	1	216		22.49	22.62	22.69		
80	216	0		22.70	22.73	22.67		
80	1	1	QPSK	23.21	23.15	23.03	20.72	0.1180
80	1	215		22.85	22.90	23.02		
80	108	54		23.08	23.06	23.09		
80	1	0		22.35	22.26	22.18		
80	1	216		22.02	22.01	22.16		
80	216	0		22.15	22.14	22.14		
80	1	1	16-QAM	22.35	22.40	22.57	20.72	0.1180
80	1	1	64-QAM	20.92	20.45	20.33		
80	1	1	256-QAM	18.61	18.51	18.34		
Limit	EIRP < 1W			Result			Pass	



NR n78 Maximum Average Power [dBm] (GT - LC = -1.85 dB)										
BW [MHz]	RB Size	RB Offset	Mod	Lowest	Middle	Highest	EIRP (dBm)	EIRP(W)		
90	1	1	PI/2 BPSK	23.25	23.23	23.23	21.40	0.1380		
90	1	243		22.95	22.94	22.95				
90	120	60		23.01	22.98	23.03				
90	1	0		22.87	22.86	22.84				
90	1	244		22.50	22.51	22.57				
90	243	0		22.66	22.58	22.59				
90	1	1	QPSK	23.18	23.16	23.14			20.66	0.1164
90	1	243		22.87	22.83	22.97				
90	120	60		23.00	22.95	23.01				
90	1	0		22.30	22.25	22.28				
90	1	244		21.92	21.97	22.03				
90	243	0		22.07	22.08	22.05				
90	1	1	16-QAM	22.47	22.51	22.26	20.66	0.1164		
90	1	1	64-QAM	20.90	20.38	20.39				
90	1	1	256-QAM	18.73	18.48	18.41				
Limit	EIRP < 1W			Result			Pass			

NR n78 Maximum Average Power [dBm] (GT - LC = -1.85 dB)										
BW [MHz]	RB Size	RB Offset	Mod	Lowest	Middle	Highest	EIRP (dBm)	EIRP(W)		
100	1	1	PI/2 BPSK	-	23.18	-	21.33	0.1358		
100	1	271		-	22.92	-				
100	135	67		-	22.94	-				
100	1	0		-	22.81	-				
100	1	272		-	22.51	-				
100	270	0		-	22.48	-				
100	1	1	QPSK	-	23.15	-			20.46	0.1112
100	1	271		-	22.89	-				
100	135	67		-	22.93	-				
100	1	0		-	22.23	-				
100	1	272		-	21.91	-				
100	270	0		-	22.05	-				
100	1	1	16-QAM	-	22.31	-	20.46	0.1112		
100	1	1	64-QAM	-	20.73	-				
100	1	1	256-QAM	-	18.53	-				
Limit	EIRP < 1W			Result			Pass			



FR1 n2

Peak-to-Average Ratio

Mode	FR1 n2 / 20MHz / DFT-S OFDM				
Mod.	PI/2 BPSK	QPSK	16QAM	64QAM	Limit: 13dB
RB Size	Full RB	Full RB	Full RB	Full RB	Result
Middle CH	4.74	5.38	6.42	6.74	PASS
Mode	FR1 n2 / 20MHz / DFT-S OFDM				
Mod.	256QAM				Limit: 13dB
RB Size	Full RB				Result
Middle CH	7.30				PASS



FR1 n2 / 20MHz / DFT-S OFDM / Middle Channel / Full RB

PI/2 BPSK

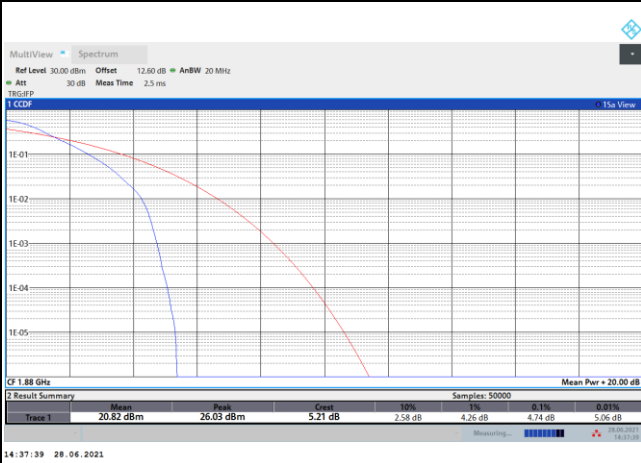

QPSK

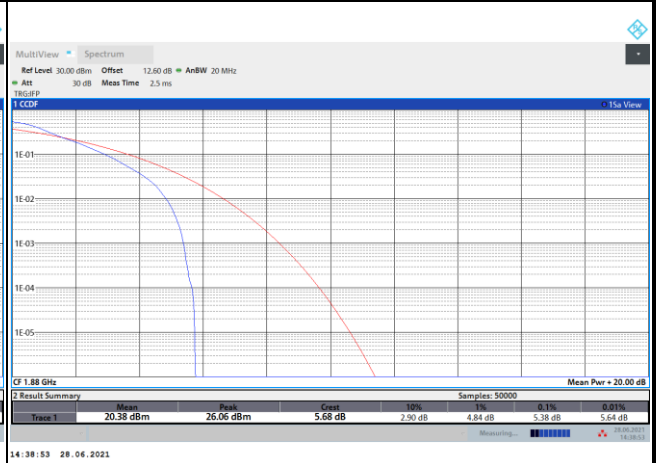

16QAM

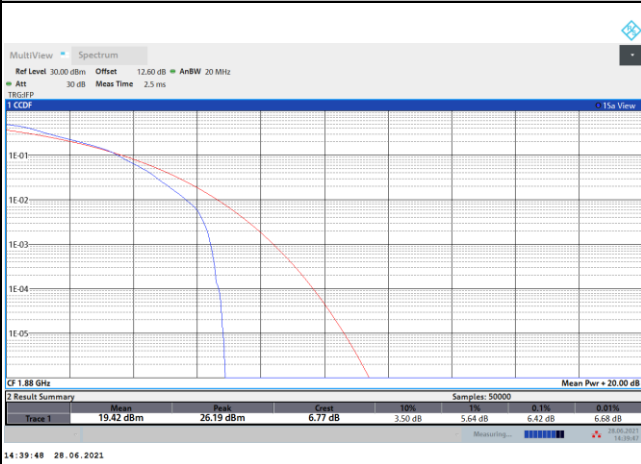

64QAM

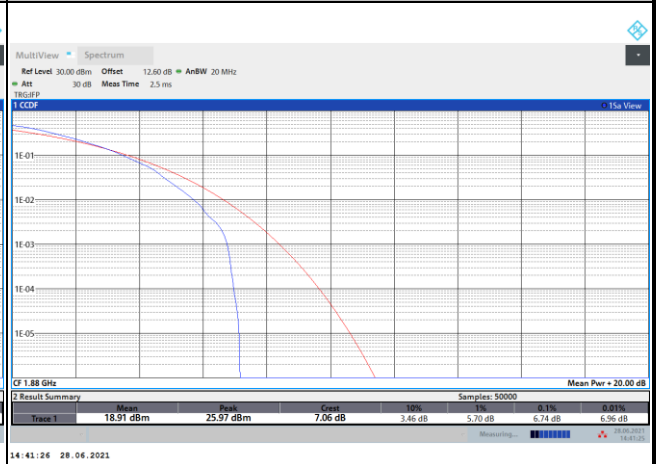

256QAM

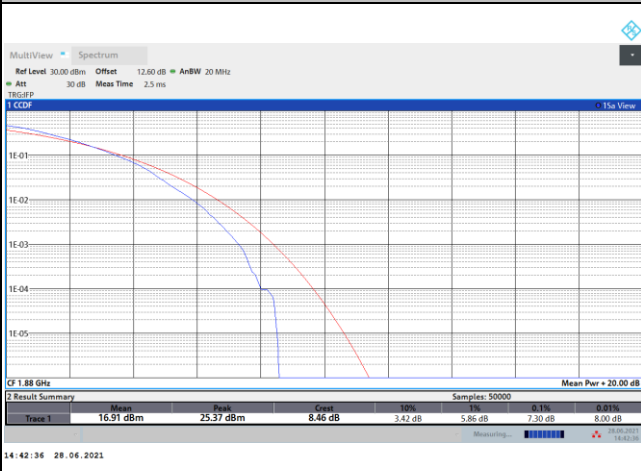



26dB Bandwidth

Mode	FR1 n2 : 26dB BW(MHz) / DFT-S OFDM							
BW	5MHz		10MHz		15MHz		20MHz	
Mod.	PI/2 BPSK		PI/2 BPSK		PI/2 BPSK		PI/2 BPSK	
Middle CH	4.85		9.55		14.30		18.74	

Mode	FR1 n2 : 26dB BW(MHz) / CP OFDM							
BW	5MHz		10MHz		15MHz		20MHz	
Mod.	QPSK	16QAM	QPSK	16QAM	QPSK	16QAM	QPSK	16QAM
Middle CH	4.96	4.89	9.91	9.79	14.93	14.90	19.82	19.86
Mod.	64QAM	256QAM	64QAM	256QAM	64QAM	256QAM	64QAM	256QAM
Middle CH	4.88	4.95	9.77	9.77	15.05	14.96	19.82	19.86



FR1 n2 / 5MHz / DFT-S OFDM / Middle Channel / Full RB

PI/2 BPSK

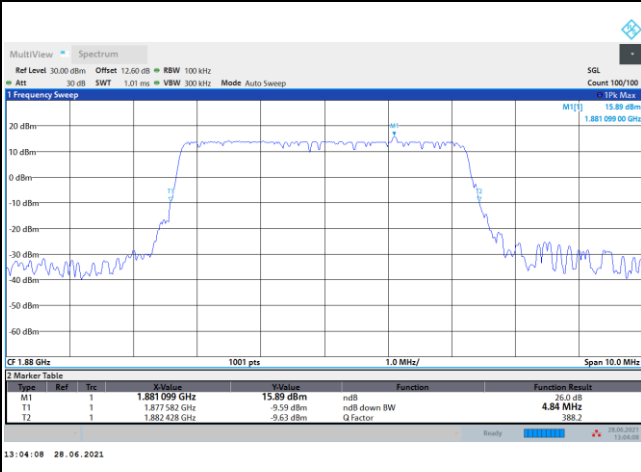

FR1 n2 / 5MHz / CP OFDM / Middle Channel / Full RB

QPSK

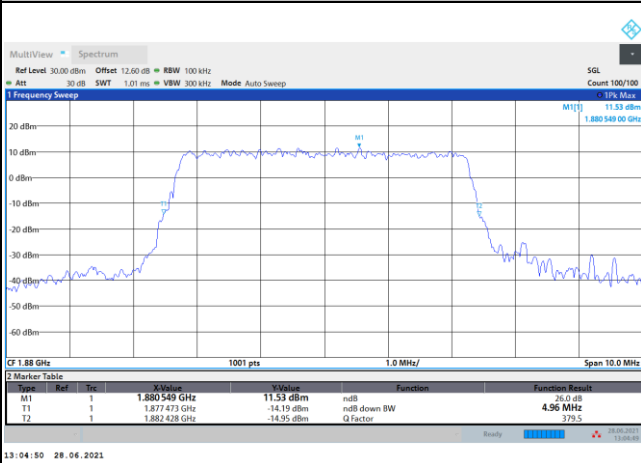

16QAM

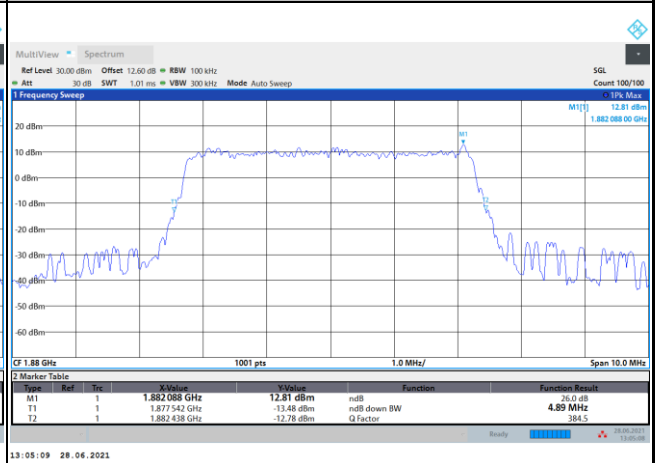

64QAM

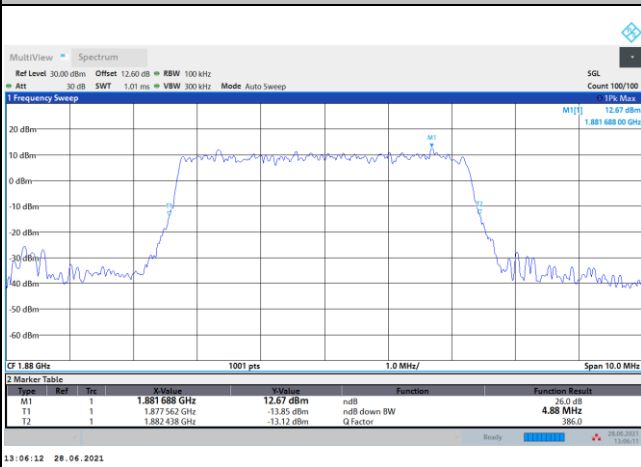

256QAM

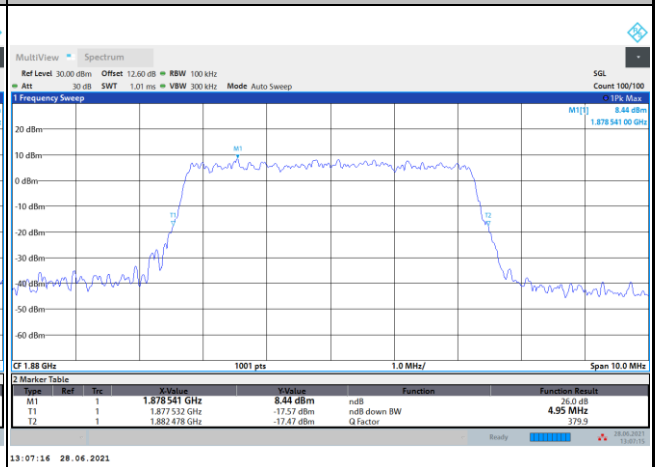



FR1 n2 / 10MHz / DFT-S OFDM / Middle Channel / Full RB

PI/2 BPSK

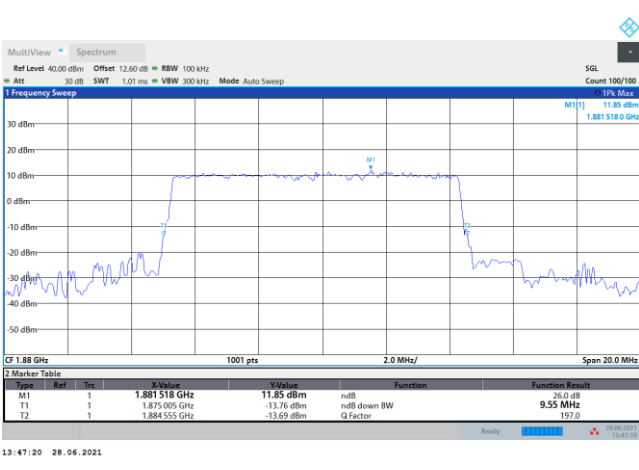

FR1 n2 / 10MHz / CP OFDM / Middle Channel / Full RB

QPSK

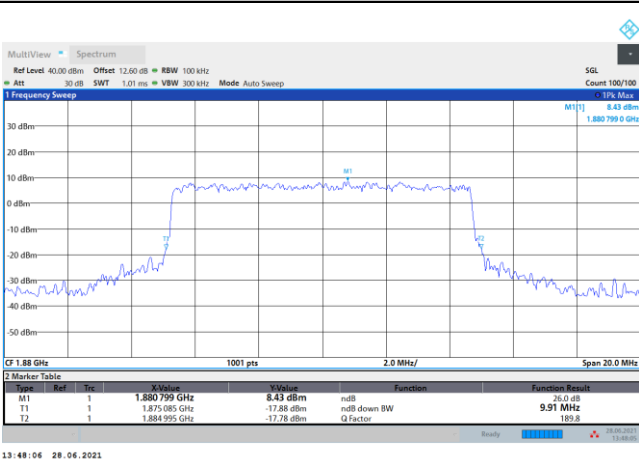

16QAM

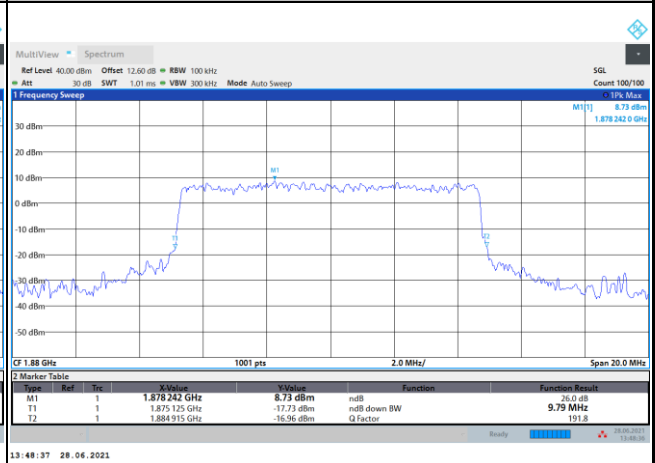

64QAM

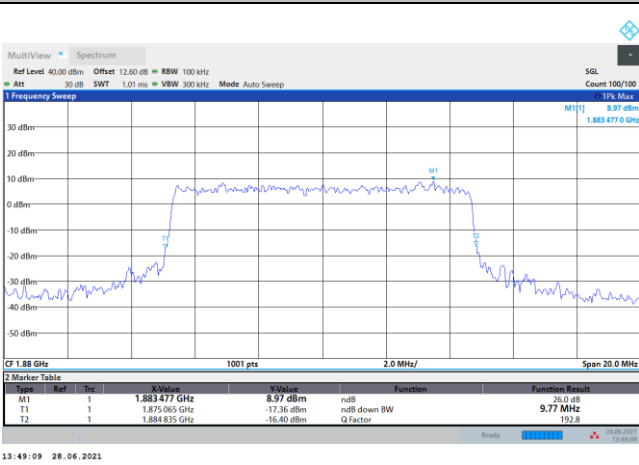

256QAM

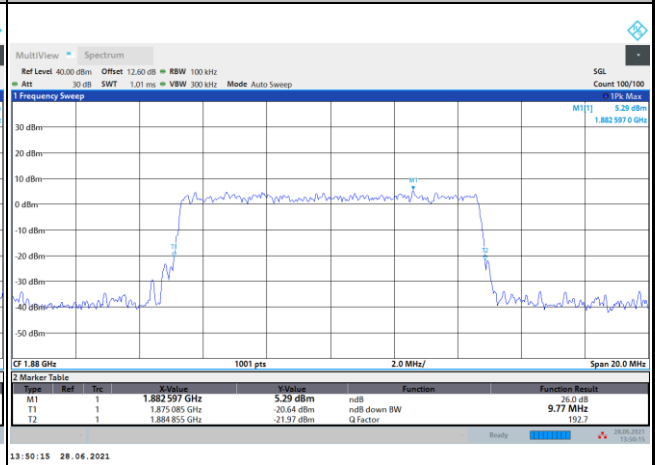



FR1 n2 / 15MHz / DFT-S OFDM / Middle Channel / Full RB

PI/2 BPSK

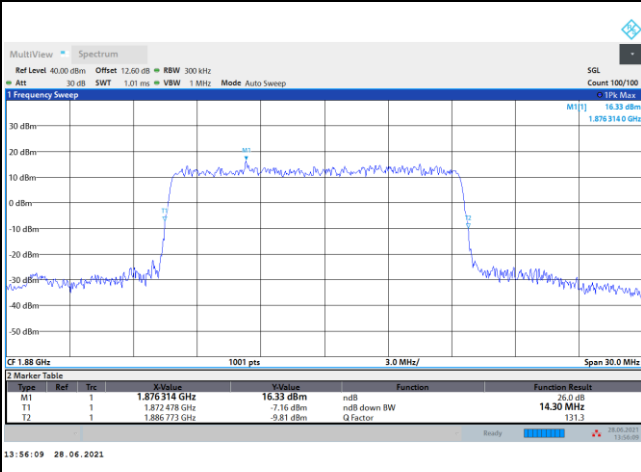

FR1 n2 / 15MHz / CP OFDM / Middle Channel / Full RB

QPSK

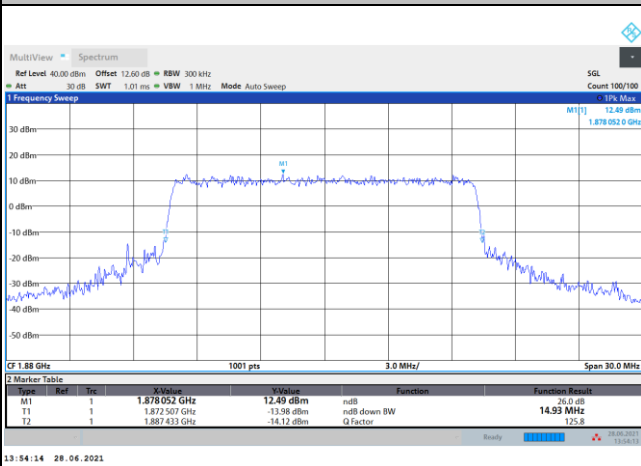

16QAM

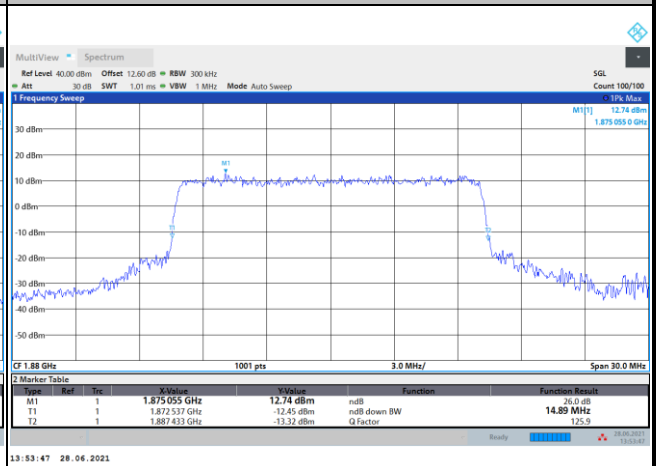

64QAM

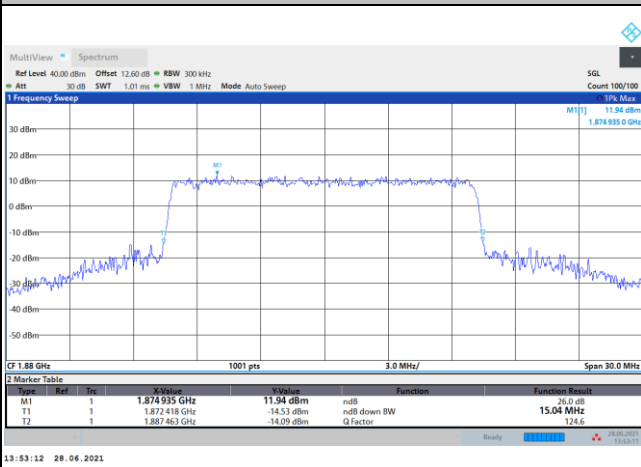

256QAM

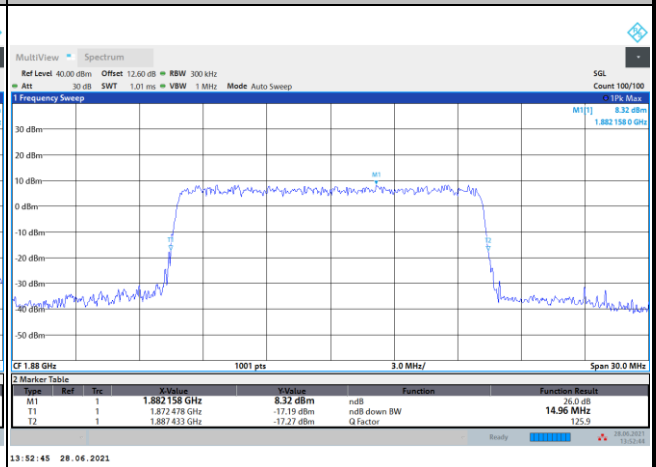



FR1 n2 / 20MHz / DFT-S OFDM / Middle Channel / Full RB

PI/2 BPSK

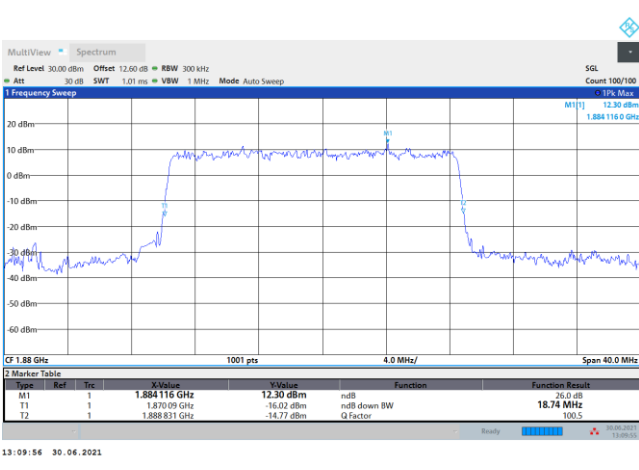

FR1 n2 / 20MHz / CP OFDM / Middle Channel / Full RB

QPSK

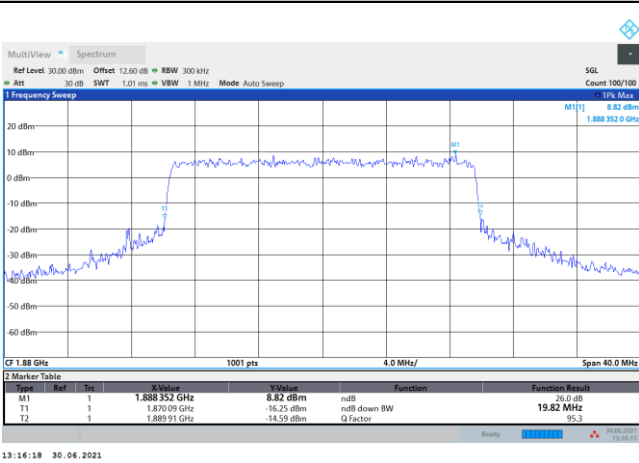

16QAM

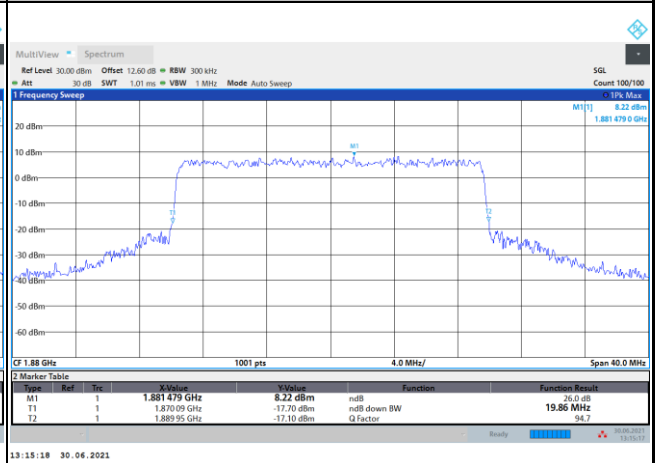

64QAM

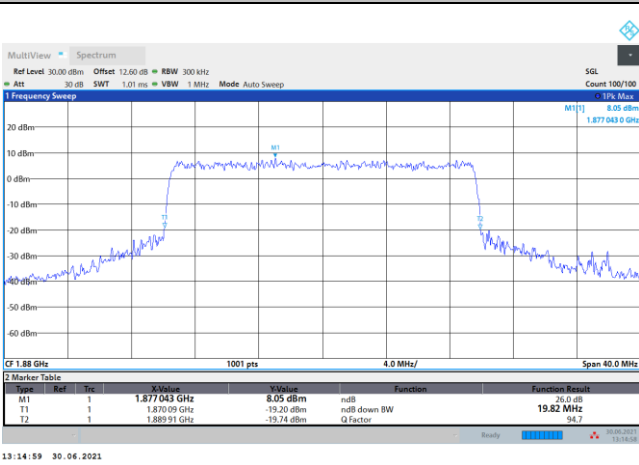

256QAM

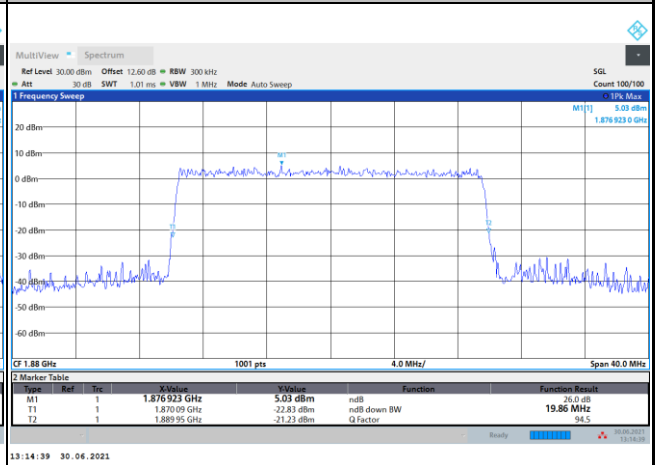



Occupied Bandwidth

Mode	FR1 n2 : 99%OBW(MHz) / DFT-S OFDM							
BW	5MHz		10MHz		15MHz		20MHz	
Mod.	PI/2 BPSK		PI/2 BPSK		PI/2 BPSK		PI/2 BPSK	
Middle CH	4.46		8.93		13.50		17.89	

Mode	FR1 n2 : 99%OBW (MHz) / CP OFDM							
BW	5MHz		10MHz		15MHz		20MHz	
Mod.	QPSK	16QAM	QPSK	16QAM	QPSK	16QAM	QPSK	16QAM
Middle CH	4.50	4.48	9.26	9.27	14.13	14.15	18.95	18.93
Mod.	64QAM	256QAM	64QAM	256QAM	64QAM	256QAM	64QAM	256QAM
Middle CH	4.50	4.50	9.25	9.28	14.21	14.14	18.95	18.89



FR1 n2 / 5MHz / DFT-S OFDM / Middle Channel / Full RB

PI/2 BPSK

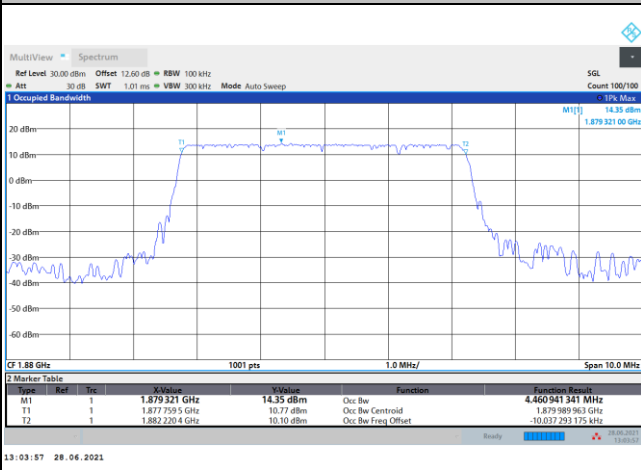

FR1 n2 / 5MHz / CP OFDM / Middle Channel / Full RB

QPSK

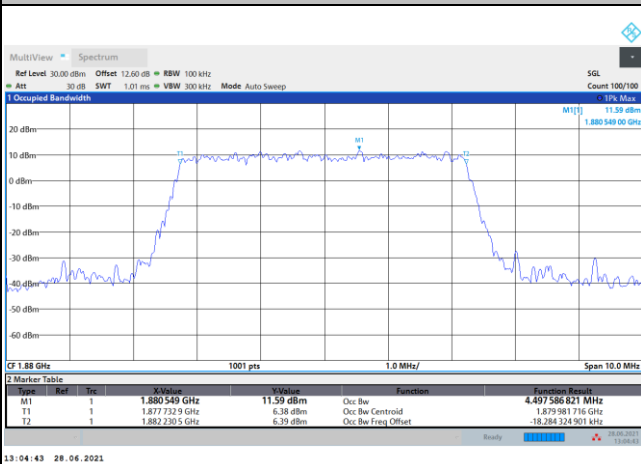

16QAM

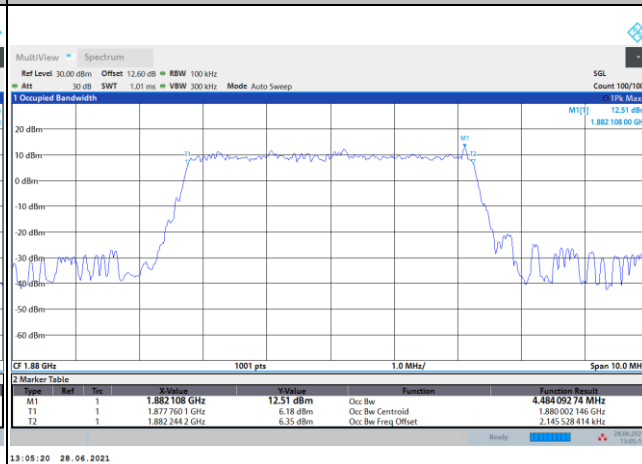

64QAM

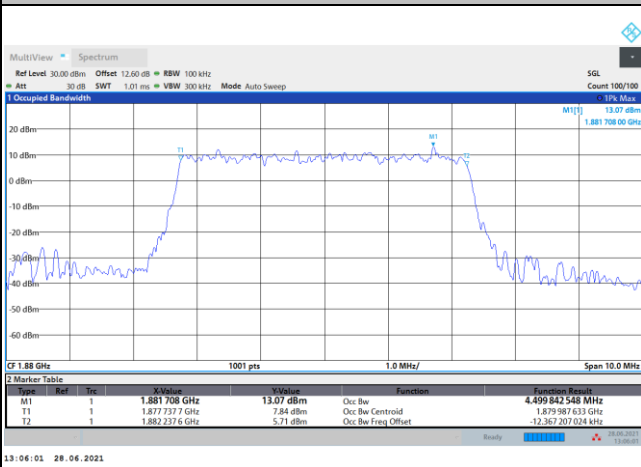

256QAM

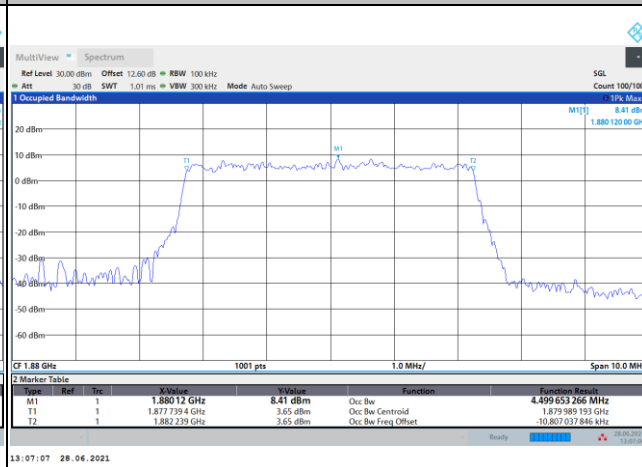



FR1 n2 / 10MHz / DFT-S OFDM / Middle Channel / Full RB

PI/2 BPSK

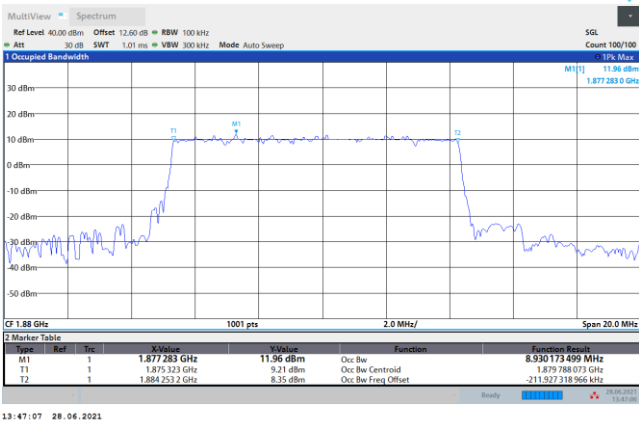

FR1 n2 / 10MHz / CP OFDM / Middle Channel / Full RB

QPSK

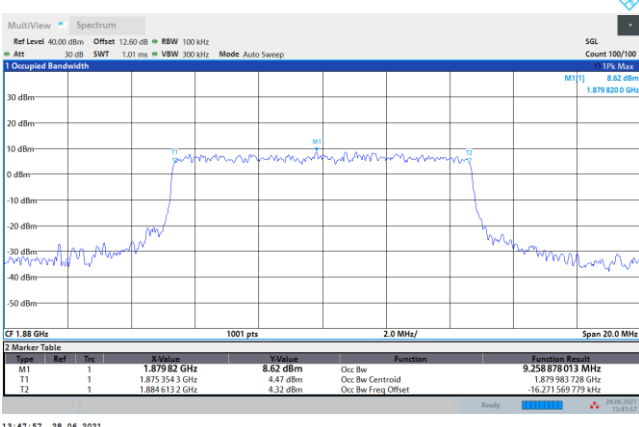

16QAM

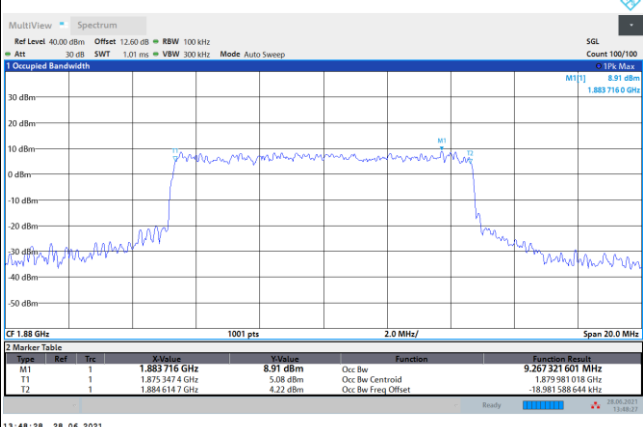

64QAM

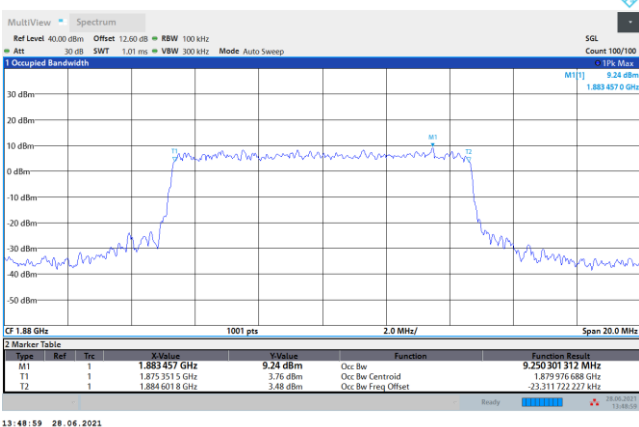

256QAM

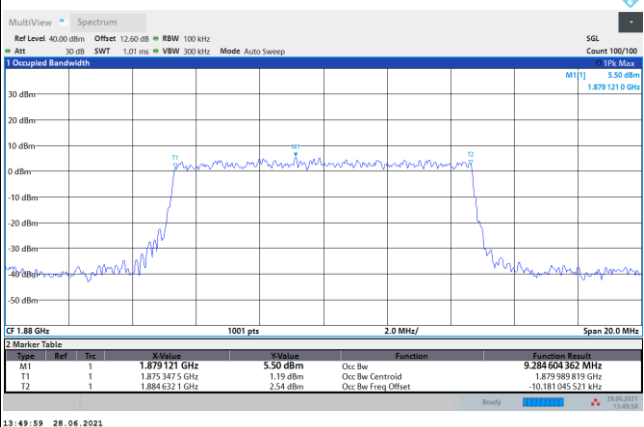



FR1 n2 / 15MHz / DFT-S OFDM / Middle Channel / Full RB

PI/2 BPSK

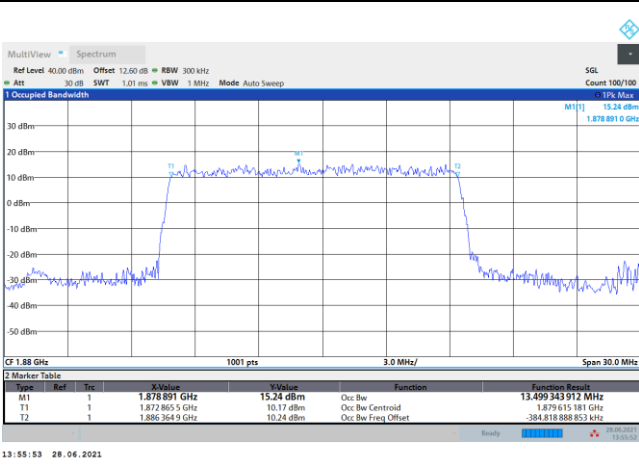

FR1 n2 / 15MHz / CP OFDM / Middle Channel / Full RB

QPSK

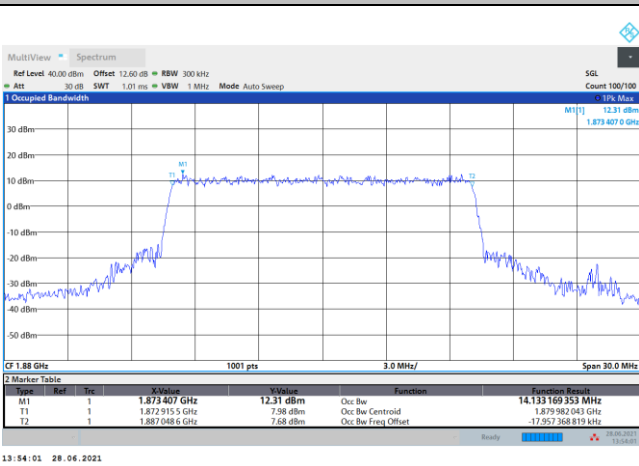

16QAM

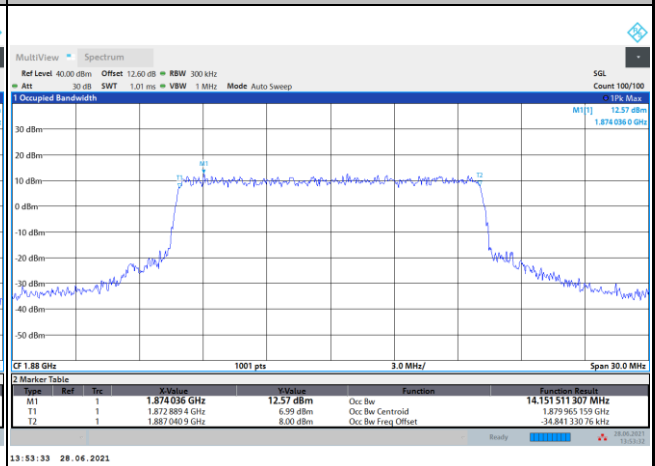

64QAM

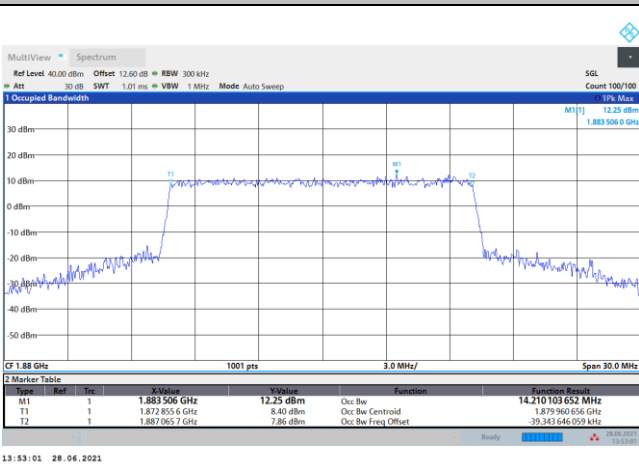

256QAM

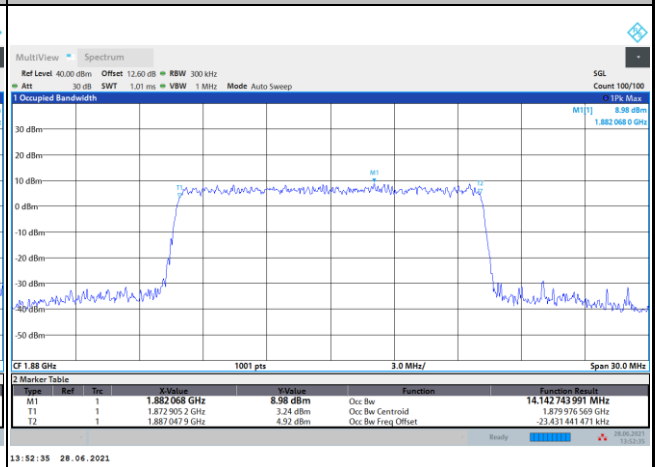



FR1 n2 / 20MHz / DFT-S OFDM / Middle Channel / Full RB

PI/2 BPSK

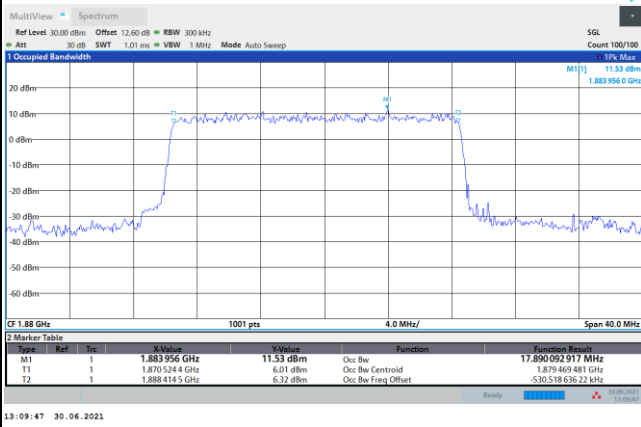

FR1 n2 / 20MHz / CP OFDM / Middle Channel / Full RB

QPSK

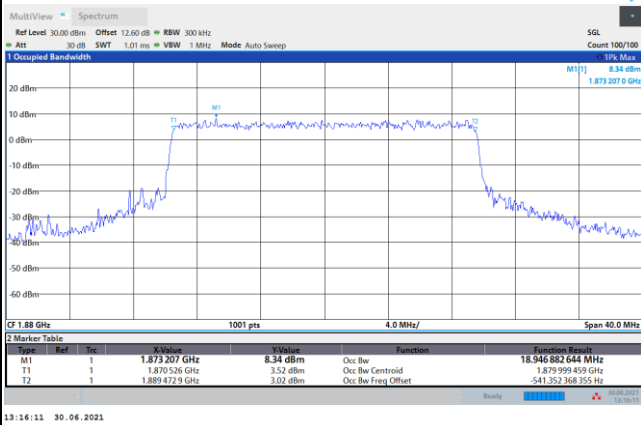

16QAM

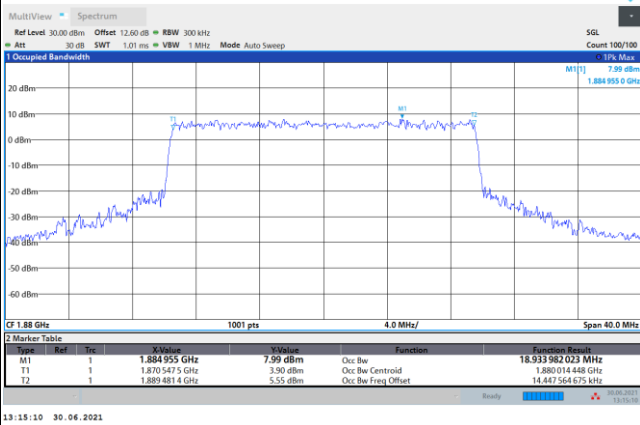

64QAM

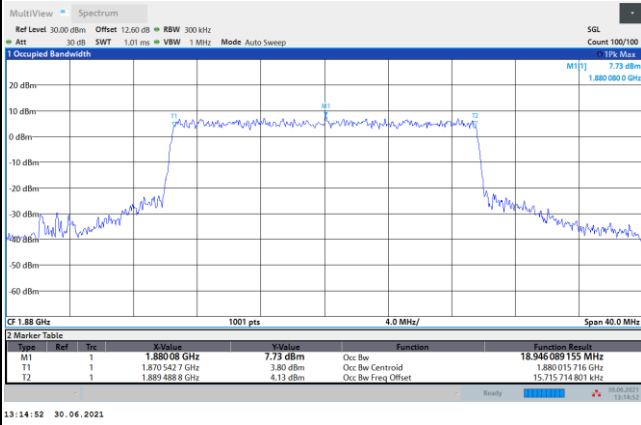

256QAM

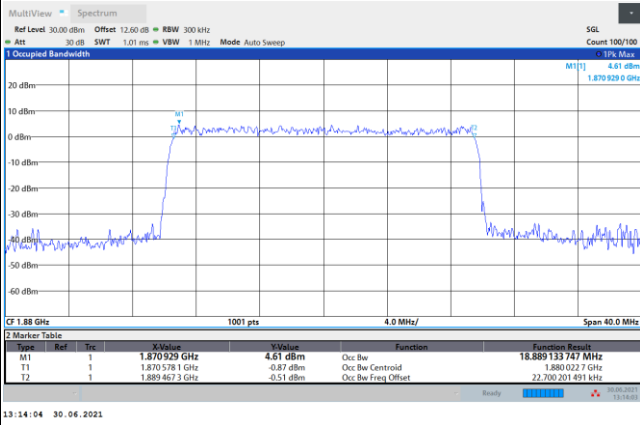



Conducted Band Edge

FR1 n2 / 5MHz / DFT-S OFDM / PI/2 BPSK

Lowest Band Edge / 1RB0

Highest Band Edge / 1RBmax

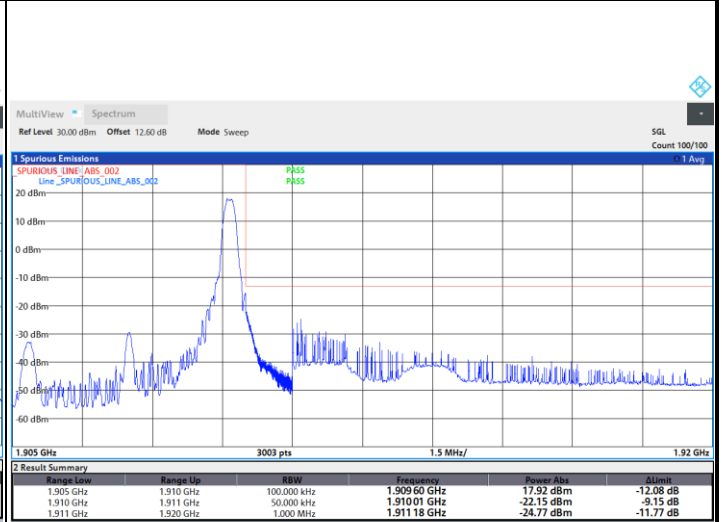
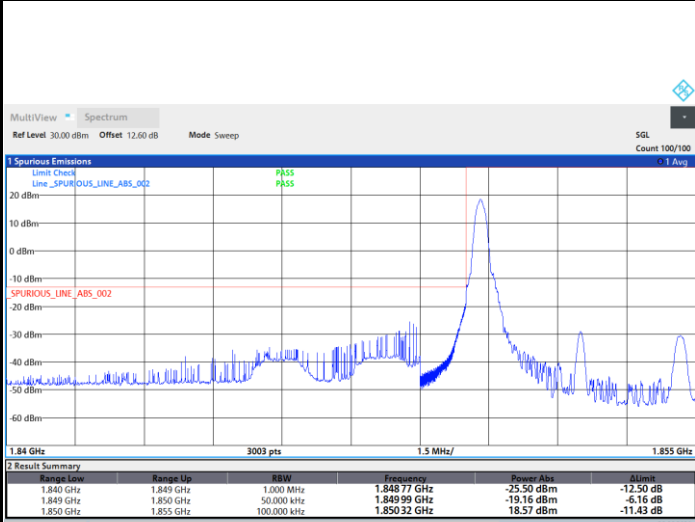

12:34:12 28.06.2021

13:11:27 28.06.2021

Lowest Band Edge / Full RB

Highest Band Edge / Full RB

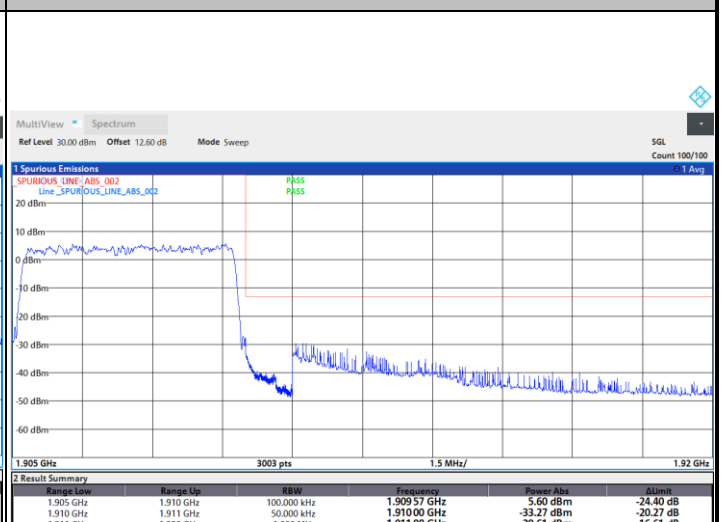
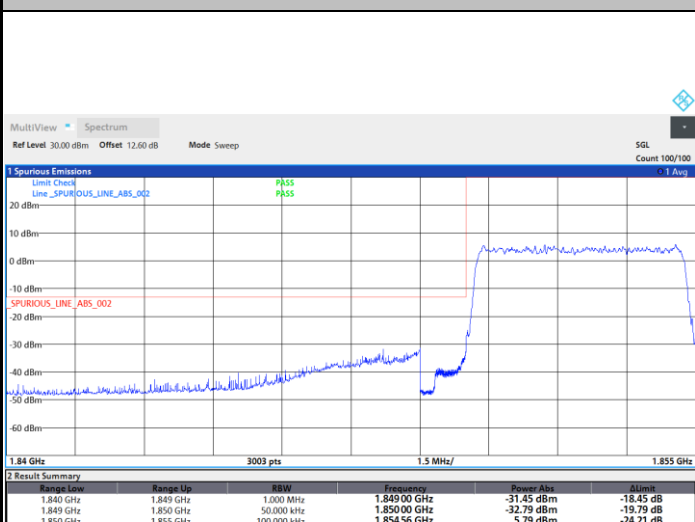

12:43:37 28.06.2021

13:20:31 28.06.2021



FR1 n2 / 5MHz / DFT-S OFDM / QPSK

Lowest Band Edge / 1RB0

Highest Band Edge / 1RBmax

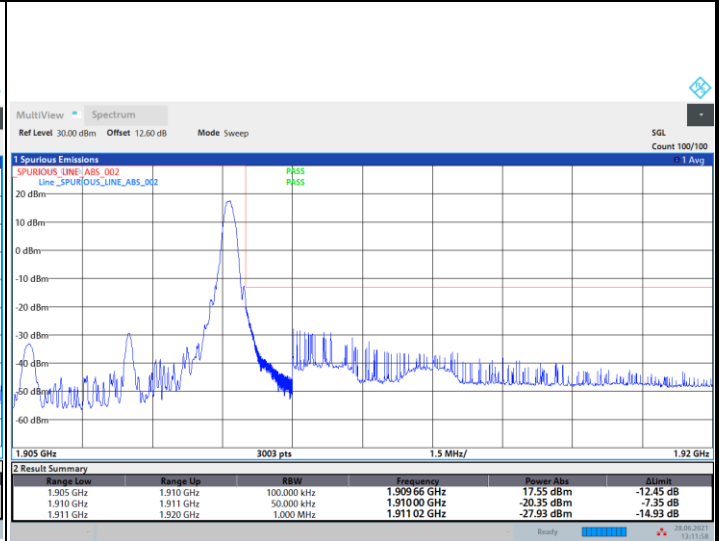
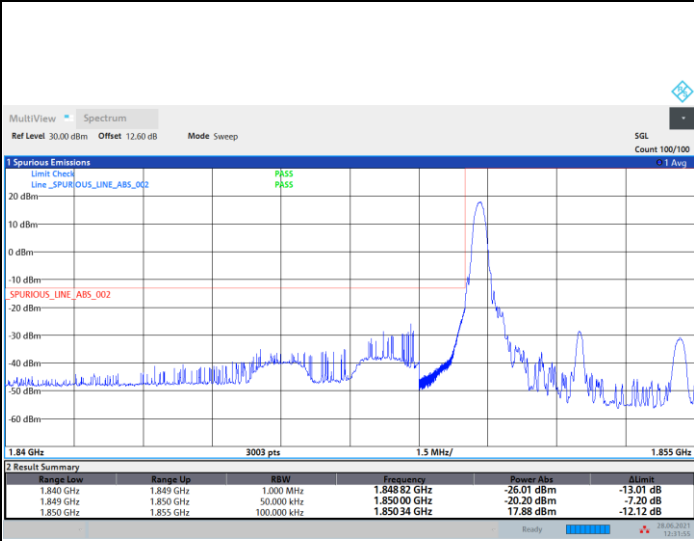

Lowest Band Edge / Full RB

Highest Band Edge / Full RB

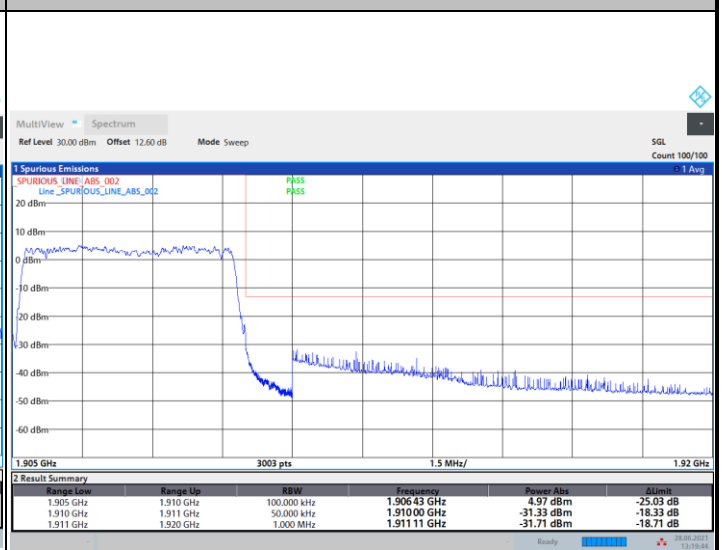
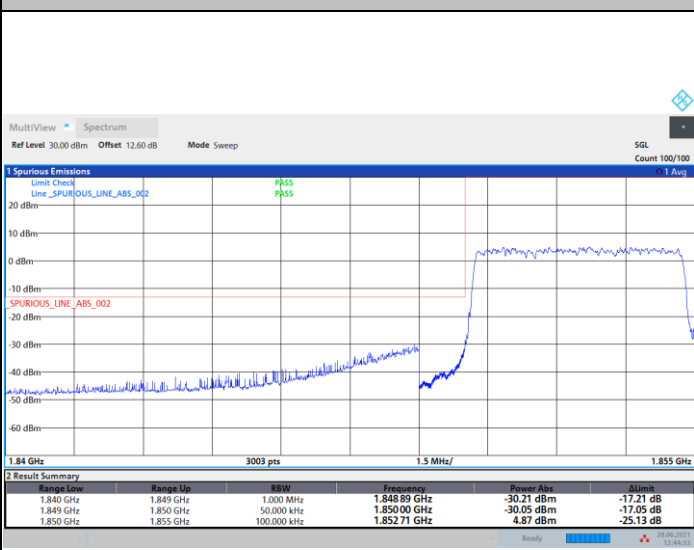



FR1 n2 / 5MHz / DFT-S OFDM / 16QAM

Lowest Band Edge / 1RB0

Highest Band Edge / 1RBmax

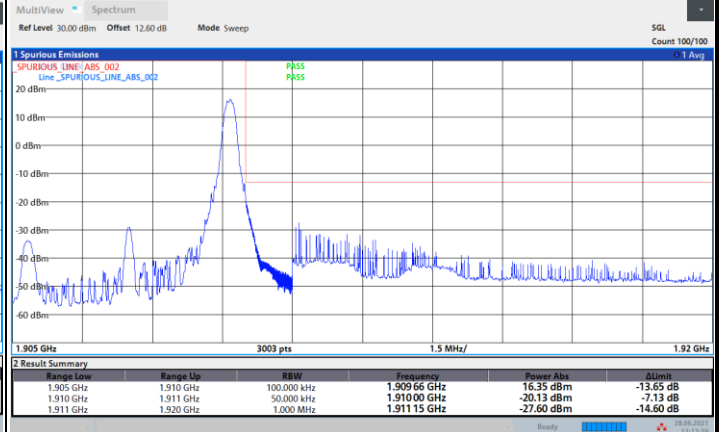
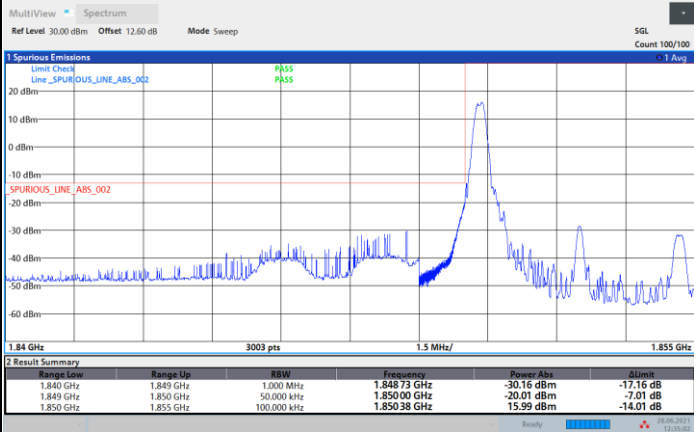

Lowest Band Edge / Full RB

Highest Band Edge / Full RB

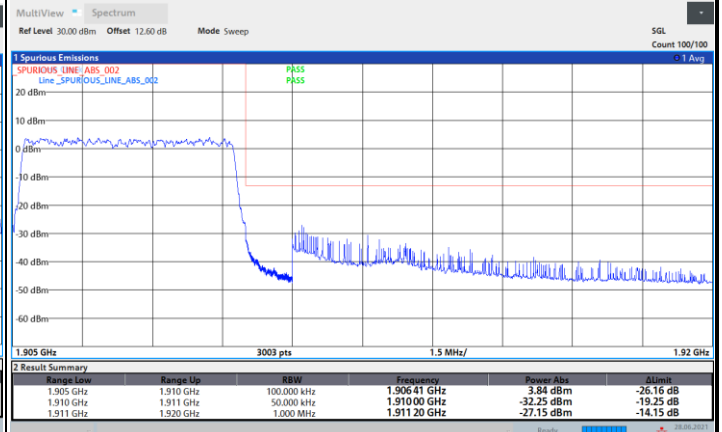
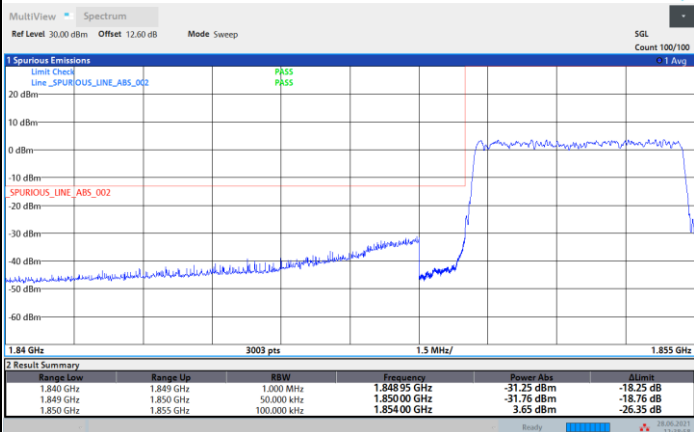



FR1 n2 / 5MHz / DFT-S OFDM / 64QAM

Lowest Band Edge / 1RB0

Highest Band Edge / 1RBmax

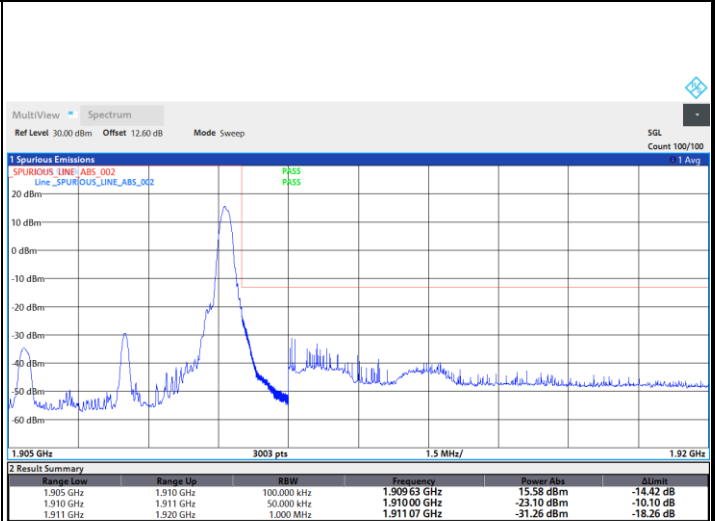
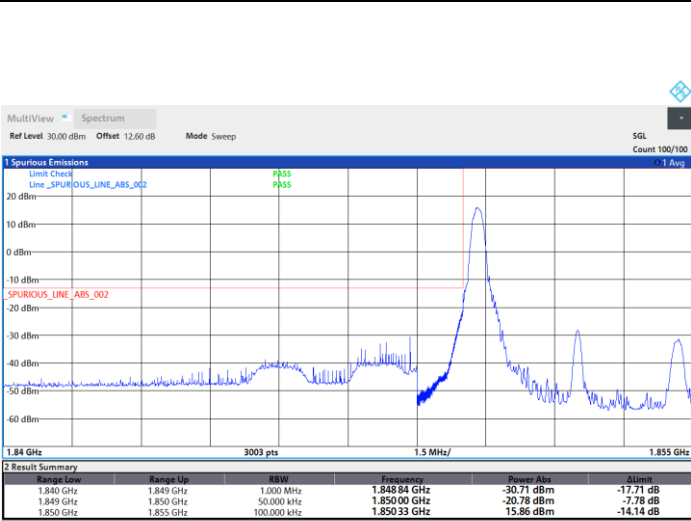

12:35:44 28.06.2021

13:13:01 28.06.2021

Lowest Band Edge / Full RB

Highest Band Edge / Full RB

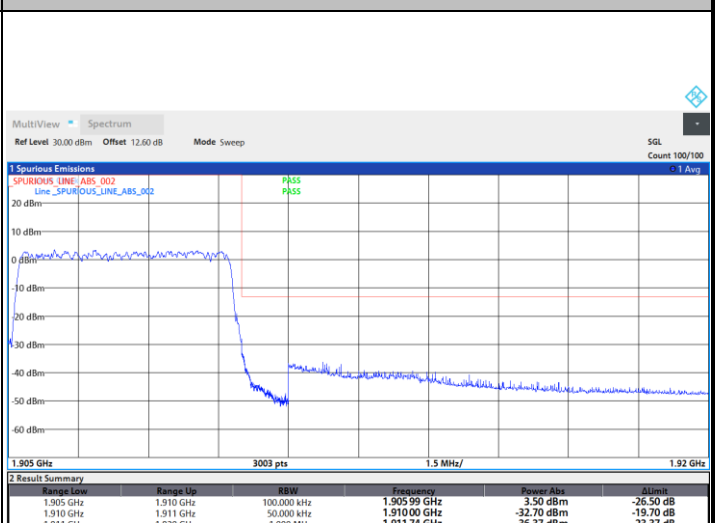
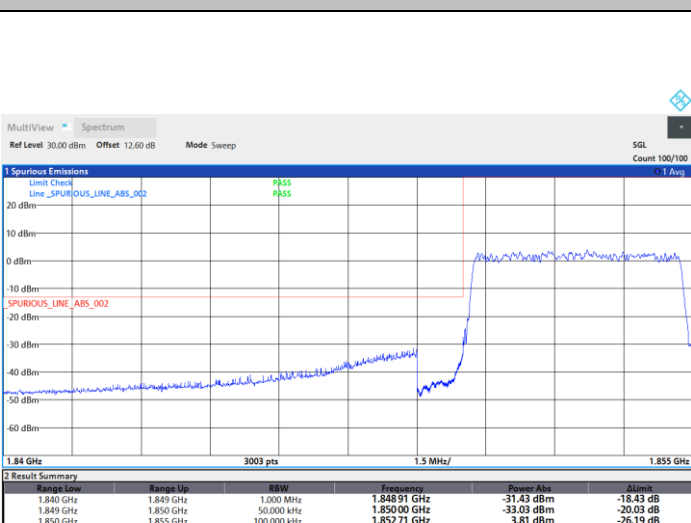

12:38:24 28.06.2021

13:18:24 28.06.2021



FR1 n2 / 5MHz / DFT-S OFDM / 256QAM

Lowest Band Edge / 1RB0

Highest Band Edge / 1RBmax

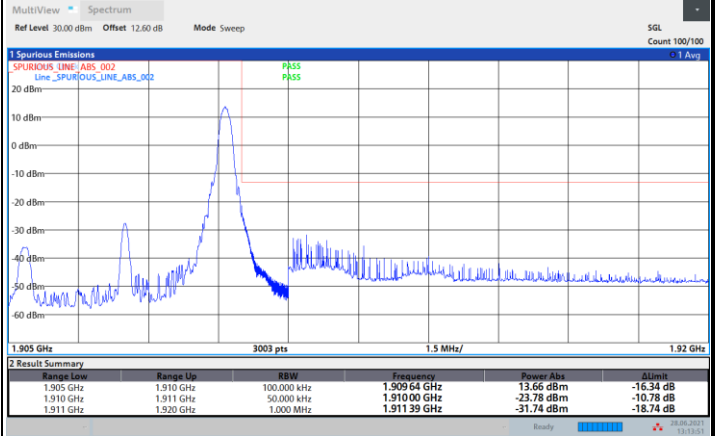
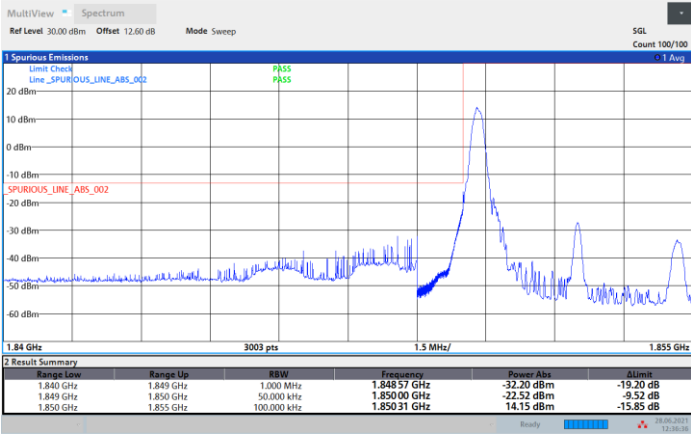

Lowest Band Edge / Full RB

Highest Band Edge / Full RB

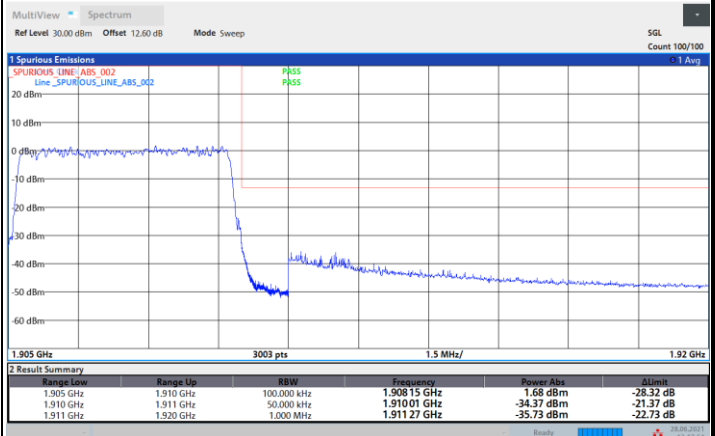
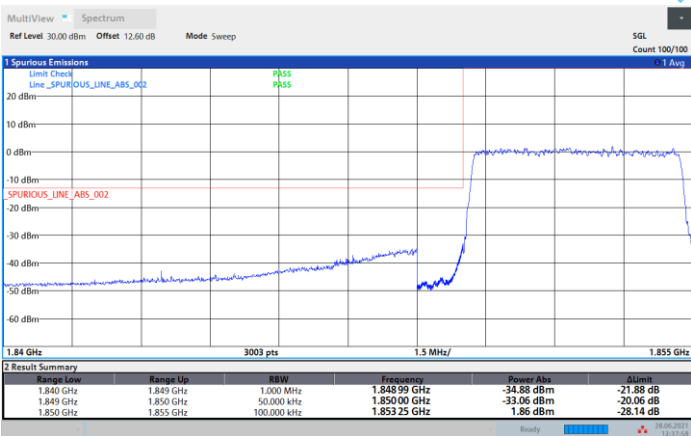



FR1 n2 / 5MHz / CP OFDM / QPSK / Full RB

Lowest Band Edge

Highest Band Edge

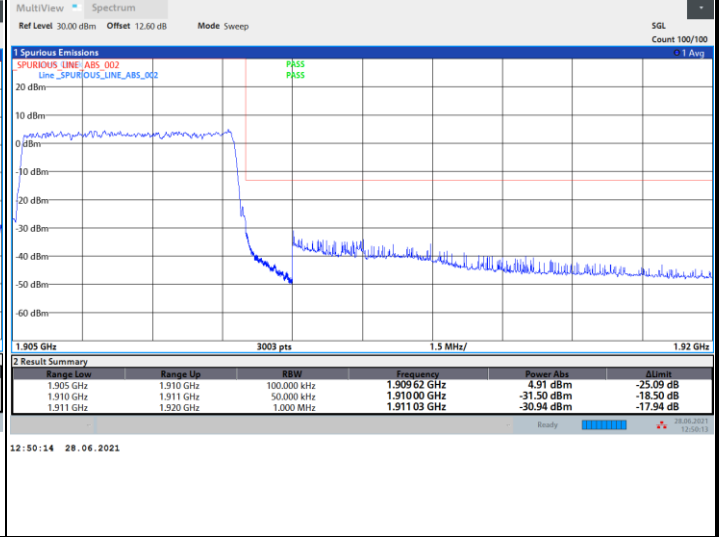
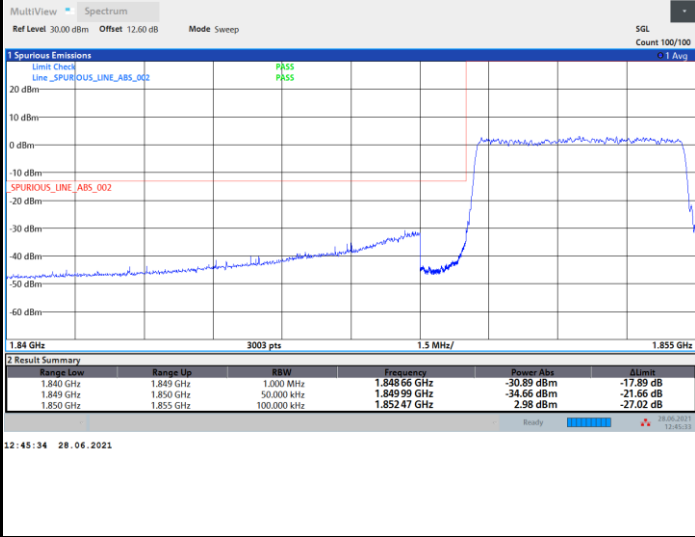

FR1 n2 / 10MHz / DFT-s-OFDM / PI/2 BPSK / Full RB

Lowest Band Edge

Highest Band Edge

