

FCC LTE REPORT

FCC Certification

Applicant Name:
Franklin Technology Inc.

Date of Issue:
November 26, 2015

Address:
906(Gasan-Dong, JEI Platz), 186, Gasan digital 1-ro,
Geumcheon-gu, Seoul, Korea(08502)

Location:
HCT CO., LTD.,
74, Seoicheon-ro 578beon-gil, Majang-myeon,
Icheon-si, Gyeonggi-do, 17383, Rep. of KOREA

Report No.: HCT-R-1511-F025
HCT FRN: 0005866421

MODEL: XHG-R850

APPLICANT: Franklin Technology Inc.

FCC Model(s): R850
EUT Type: LTE Mobile Router
FCC Classification: PCS Licensed Transmitter (PCB)
FCC Rule Part(s): §90.691, §2

Mode (MHz)	Tx Frequency (MHz)	Emission Designator	Modulation	ERP	
				Max. Power (W)	Max. Power (dBm)
LTE - Band26 (1.4)	814.7 – 823.3	1M09G7D	QPSK	0.120	20.79
		1M08W7D	16QAM	0.099	19.94
LTE - Band26 (3)	815.5 – 822.5	2M69G7D	QPSK	0.123	20.90
		2M68W7D	16QAM	0.104	20.18
LTE - Band26 (5)	816.5 – 821.5	4M47G7D	QPSK	0.146	21.64
		4M48W7D	16QAM	0.128	21.09
LTE - Band26 (10)	819.0	8M97G7D	QPSK	0.130	21.14
		8M94W7D	16QAM	0.110	20.42

The measurements shown in this report were made in accordance with the procedures specified in CFR47 section §2.947. I assume full responsibility for the accuracy and completeness of these measurements, and for the qualifications of all persons taking them.

HCT CO., LTD. Certifies that no party to this application has subject to a denial of Federal benefits that includes FCC benefits pursuant to section 5301 of the Anti-Drug Abuse Act of 1998,21 U.S. C.853(a)



Report prepared by
: Ki Hyun Kim
Test engineer of RF Team



Approved by
: Sang Jun Lee
Manager of RF Team

This report only responds to the tested sample and may not be reproduced, except in full, without written approval of the HCT Co., Ltd.

Report Revision

TEST REPORT NO.	DATE	DESCRIPTION
HCT-R-1511-F025	November 26, 2015	- First Approval Report

Table of Contents

1. GENERAL INFORMATION	4
2. INTRODUCTION	5
2.1. EUT DESCRIPTION.....	5
2.2. MEASURING INSTRUMENT CALIBRATION.....	5
2.3. TEST FACILITY	5
3. DESCRIPTION OF TESTS	6
3.1 ERP RADIATED POWER AND RADIATED SPURIOUS EMISSIONS	6
3.2 OCCUPIED BANDWIDTH.....	7
3.3 SPURIOUS AND HARMONIC EMISSIONS AT ANTENNA TERMINAL.....	8
3.4 FREQUENCY STABILITY / VARIATION OF AMBIENT TEMPERATURE	9
4. LIST OF TEST EQUIPMENT	10
5. SUMMARY OF TEST RESULTS	11
6. SAMPLE CALCULATION.....	12
7. TEST DATA	13
7.1 EFFECTIVE RADIATED POWER (Band 26).....	13
7.2 RADIATED SPURIOUS EMISSIONS.....	15
7.2.1 RADIATED SPURIOUS EMISSIONS (1.4 MHz Band 26 LTE).....	15
7.2.2 RADIATED SPURIOUS EMISSIONS (3 MHz Band 26 LTE).....	16
7.2.3 RADIATED SPURIOUS EMISSIONS (5 MHz Band 26 LTE).....	17
7.2.4 RADIATED SPURIOUS EMISSIONS (10 MHz Band 26 LTE).....	18
7.3 OCCUPIED BANDWIDTH	19
7.4 CONDUCTED SPURIOUS EMISSIONS	20
7.4.1 BAND EDGE.....	20
7.8 FREQUENCY STABILITY / VARIATION OF AMBIENT TEMPERATURE	21
8. TEST PLOTS.....	22

MEASUREMENT REPORT

1. GENERAL INFORMATION

Applicant Name: Franklin Technology Inc.

Address: 906(Gasan-Dong, JEI Platz), 186, Gasan digital 1-ro, Geumcheon-gu, Seoul, Korea(08502)

FCC ID: XHG-R850

Application Type: Certification

FCC Classification: PCS Licensed Transmitter (PCB)

FCC Rule Part(s): §90.691, §2

EUT Type: LTE Mobile Router

FCC Model(s): R850

Tx Frequency: 814.7 MHz – 823.3 MHz (LTE – Band 26 (1.4 MHz))
815.5 MHz – 822.5 MHz (LTE – Band 26 (3 MHz))
816.5 MHz – 821.5 MHz (LTE – Band 26 (5 MHz))
819.0 MHz (LTE – Band 26 (10 MHz))

Max. RF Output Power:

Band 26 (1.4 MHz) :	0.120 W (QPSK) (20.79 dBm)
	0.099 W (16-QAM) (19.94 dBm)
Band 26 (3 MHz) :	0.123 W (QPSK) (20.90 dBm)
	0.104 W (16-QAM) (20.18 dBm)
Band 26 (5 MHz) :	0.146 W (QPSK) (21.64 dBm)
	0.128 W (16-QAM) (21.09 dBm)
Band 26 (10 MHz) :	0.130 W (QPSK) (21.14 dBm)
	0.110 W (16-QAM) (20.42 dBm)

Emission Designator(s):

Band 26 (1.4 MHz) :	1M09G7D (QPSK) / 1M08W7D (16-QAM)
Band 26 (3 MHz) :	2M69G7D (QPSK) / 2M68W7D (16-QAM)
Band 26 (5 MHz) :	4M47G7D (QPSK) / 4M48W7D (16-QAM)
Band 26 (10 MHz) :	8M97G7D (QPSK) / 8M94W7D (16-QAM)

Date(s) of Tests: October 20, 2015 ~ November 25, 2015

Antenna Specification

Manufacturer:	Hutec
Antenna type:	Internal Antenna
Peak Gain:	Band 26 : 0.88 dBi

2. INTRODUCTION

2.1. EUT DESCRIPTION

The Franklin Technology Inc. R850 LTE Mobile Router consists of LTE 26.

2.2. MEASURING INSTRUMENT CALIBRATION

The measuring equipment, which was utilized in performing the tests documented herein, has been calibrated in accordance with the manufacturer's recommendations for utilizing calibration equipment, which is traceable to recognized national standards.

2.3. TEST FACILITY

The Fully-anechoic chamber and conducted measurement facility used to collect the radiated data are located at the **74, Seoicheon-ro 578beon-gil, Majang-myeon, Icheon-si, Gyeonggi-do, 17383, Rep. of KOREA.**

3. DESCRIPTION OF TESTS

3.1 ERP RADIATED POWER AND RADIATED SPURIOUS EMISSIONS

Note: ERP(Effective Radiated Power)

Test Procedure

Radiated emission measurements are performed in the Fully-anechoic chamber. The equipment under test is placed on a non-conductive table 3-meters away from the receive antenna in accordance with ANSI/TIA-603-D-2010 Clause 2.2.17. The turntable is rotated through 360 degrees, and the receiving antenna scans in order to determine the level of the maximized emission. The level and position of the maximized emission is recorded with the spectrum analyzer using a RMS detector.

A half wave dipole is then substituted in place of the EUT. For emissions above 1GHz, a horn antenna is substituted in place of the EUT. The substitute antenna is driven by a signal generator and the previously recorded signal was duplicated.

The power is calculated by the following formula;

$$P_{d(\text{dBm})} = P_{g(\text{dBm})} - \text{cable loss}_{(\text{dB})} + \text{antenna gain}_{(\text{dB})}$$

Where: P_d is the dipole equivalent power and P_g is the generator output power into the substitution antenna.

Radiated spurious emissions

1. Frequency Range : 30 MHz ~ 10th Harmonics of highest channel fundamental frequency.

3.2 OCCUPIED BANDWIDTH.

Test set-up

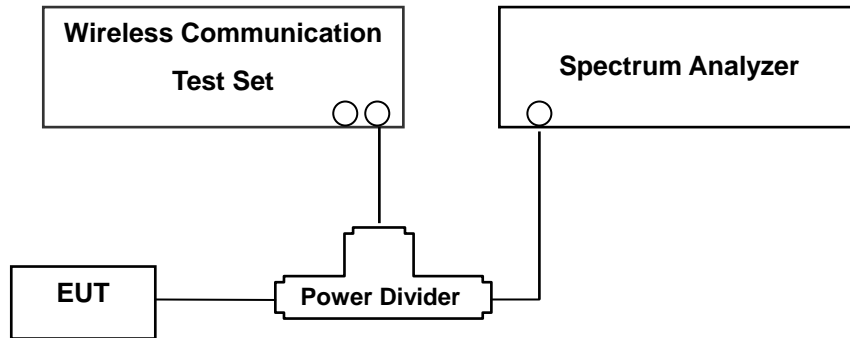

(Configuration of conducted Emission measurement)

The width of a frequency band such that, below the lower and above the upper frequency limits, the mean powers emitted are each equal to a specified percentage 0.5 % of the total mean power of a given emission.

Test Procedure

OBW is tested in accordance with KDB971168 D01 Power Meas License Digital Systems v02r02, October 17, 2014, Section 4.2.

The EUT makes a call to the communication simulator. The power was measured with R&S Spectrum Analyzer. All measurements were done at 3 channels(low, middle and high operational range.)

The conducted occupied bandwidth used the power splitter via EUT RF power connector between simulation base station and spectrum analyzer.

The communication simulator station system controlled a EUT to export maximum output power under transmission mode and specific channel frequency. Use OBW measurement function of Spectrum analyzer to measure 99 % occupied bandwidth.

3.3 SPURIOUS AND HARMONIC EMISSIONS AT ANTENNA TERMINAL.

Test Procedure

Spurious and harmonic emissions at antenna terminal is tested in accordance with KDB971168 D01 Power Meas License Digital Systems v02r02, October 17, 2014, Section 6.0.

The level of the carrier and the various conducted spurious and harmonic frequencies is measured by means of a calibrated spectrum analyzer. The spectrum is scanned from the lowest frequency generated in the equipment up to a frequency including its 10th harmonic.

Out-of-band emission requirement shall apply only to the “outer” channels included in an EA license and to spectrum adjacent to interior channels used by incumbent licensees. The emission limits are as follows:

For any frequency removed from the EA licensee's frequency block by up to and including 37.5 kHz, the power of any emission shall be attenuated below the transmitter power (P) in watts by at least $116 \text{ Log}_{10}(f/6.1)$ decibels or $50 + 10 \text{ Log}_{10}(P)$ decibels or 80 decibels, whichever is the lesser attenuation, where f is the frequency removed from the center of the outer channel in the block in kilohertz and where f is greater than 12.5 kHz.

For any frequency removed from the EA licensee's frequency block greater than 37.5 kHz, the power of any emission shall be attenuated below the transmitter power (P) in watts by at least $43 + 10 \text{ Log}_{10}(P)$ decibels or 80 decibels, whichever is the lesser attenuation, where f is the frequency removed from the center of the outer channel in the block in kilohertz and where f is greater than 37.5 kHz.

NOTES: The analyzer plot offsets were determined by below conditions.

- For LTE Band 26, total offset 26.3 dBm = 20 dBm attenuator + 6 dBm Divider + 0.3 dBm RF cables.

3.4 FREQUENCY STABILITY / VARIATION OF AMBIENT TEMPERATURE

Test Set-up

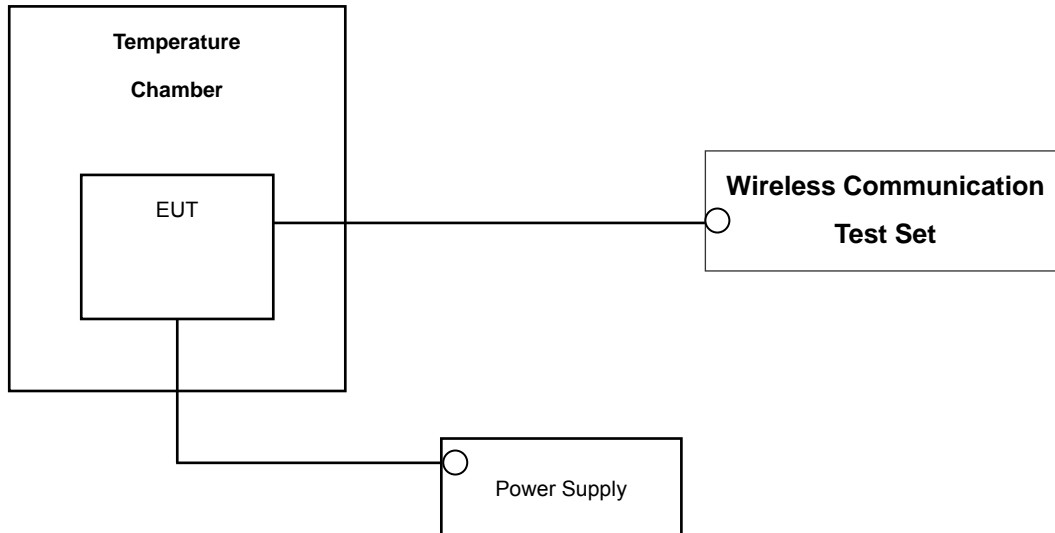

* Nominal Operating Voltage

Test Procedure

Frequency stability is tested in accordance with ANSI/TIA-603-D-2010 section 2.2.2

The frequency stability of the transmitter is measured by:

- a.) **Temperature:** The temperature is varied from - 30 °C to + 50 °C using an environmental chamber.
- b.) **Primary Supply Voltage:** The primary supply voltage is varied from the end point to 100 % of the voltage normally at the input to the device or at the power supply terminals if cables are not normally supplied.

Specification — the frequency stability of the transmitter shall be maintained within $\pm 0.00025\%$ (± 2.5 ppm) of the center frequency.

Time Period and Procedure:

The carrier frequency of the transmitter is measured at room temperature (20°C to provide a reference).

1. The equipment is turned on in a "standby" condition for one minute before applying power to the transmitter. Measurement of the carrier frequency of the transmitter is made within one minute after applying power to the transmitter.
2. Frequency measurements are made at 10°C intervals ranging from -30°C to +50°C. A period of at least one half-hour is provided to allow stabilization of the equipment at each temperature level.

NOTE: The EUT is tested down to the battery endpoint.

4. LIST OF TEST EQUIPMENT

Manufacture	Model/ Equipment	Serial Number	Calibration Interval	Calibration Due
Agilent	N1921A/ Power Sensor	MY45241059	Annual	07/09/2016
Agilent	N1911A/ Power Meter	MY45100523	Annual	07/09/2016
CERNEX	CBLU1183540B-01/POWER AMP	25540	Annual	05/21/2016
Wainwright	WHKX 10-900-1000-15000-40SS/H.P.F	5	Annual	08/11/2016
Wainwright	WHKX10-2700-3000-18000-40SS/H.P.F	3	Annual	08/05/2016
Hewlett Packard	11667B / Power Splitter	10545	Annual	02/16/2016
Hewlett Packard	11667B / Power Splitter	11275	Annual	04/29/2016
ITECH	IT6720/ Power Supply	0100215626700119	Annual	11/02/2016
Schwarzbeck	UHAP/ Dipole Antenna	557	Biennial	03/23/2017
Schwarzbeck	UHAP/ Dipole Antenna	558	Biennial	03/23/2017
EXP	EX-TH400/ Chamber	None	Annual	05/29/2016
Schwarzbeck	BBHA 9120D/ Horn Antenna	9210D-1298	Biennial	10/16/2016
Schwarzbeck	BBHA 9120D/ Horn Antenna	9210D-1299	Biennial	10/16/2016
Schwarzbeck	BBHA 9170/ Horn Antenna(15~40GHz)	BBHA9170342	Biennial	04/30/2017
Schwarzbeck	BBHA 9170/ Horn Antenna(15~35GHz)	BBHA9170124	Biennial	04/30/2017
Agilent	N9020A/Signal Analyzer	MY51110063	Annual	04/29/2016
Hewlett Packard	8493C/ATTENUATOR	17280	Annual	06/29/2016
REOHDE&SCHWARZ	FSV40-N/Signal Analyzer	101068-SZ	Annual	09/23/2016
REOHDE&SCHWARZ	FSV40/Spectrum Analyzer	1307.9002K40-100931-NK	Annual	06/04/2016
Agilent	8960 (E5515C)/ Base Station	MY48360800	Annual	10/30/2016
Anritsu Corp.	MT8820C/Wideband Radio Communication Tester	6200863156	Annual	03/24/2016

5. SUMMARY OF TEST RESULTS

FCC Part Section(s)	Test Description	Test Limit	Test Condition	Test Result
2.1049	Occupied Bandwidth	N/A	CONDUCTED	PASS
2.1051, 90.691	Band Edge / Spurious and Harmonic Emissions at Antenna Terminal.	< 50 + 10log ₁₀ (P[Watts]) at Band Edge and for all out-of-band emissions within 37.5 kHz of Block Edge		PASS
2.1046	*Conducted Output Power	N/A		PASS
2.1055, 90.213	Frequency stability / variation of ambient temperature	< 2.5 ppm		PASS
90.635	Effective Radiated Power	< 100 Watts	RADIATED	PASS
2.1053, 90.691	Undesirable Emissions	< 43 + 10log ₁₀ (P[Watts]) for all out-of band emissions		PASS

*See SAR Report

6. SAMPLE CALCULATION

A. ERP Sample Calculation

Mode	Ch./ Freq.		Measured Level(dBm)	Substitute LEVEL(dBm)	Ant. Gain (dBd)	C.L	Pol.	ERP	
	channel	Freq.(MHz)						W	dBm
LTE Band26	26697	814.7	-33.04	28.94	-10.56	0.89	V	0.056	17.49

ERP = Substitute LEVEL (dBm) + Ant. Gain – CL(Cable Loss)

- 1) The EUT mounted on a wooden tripod is 2.5 meter above test site ground level.
- 2) During the test , the turn table is rotated and the antenna height is found.
- 3) Record the field strength meter's level.
- 4) Replace the EUT with dipole/Horn antenna that is connected to a calibrated signal generator.
- 5) Increase the signal generator output till the field strength meter's level is equal to the item (3).
- 6) The signal generator output level with Ant. Gain and cable loss are the rating of effective radiated power (ERP).

B. Emission Designator

QPSK Modulation

5MHz Bandwidth

Emission Designator = 4M48G7D

LTE BW = 4.48 MHz

G = Phase Modulation

7 = Quantized/Digital Info

D = Data transmission; telemetry; telecommand

10MHz Bandwidth

Emission Designator = 8M95G7D

LTE BW = 8.95 MHz

G = Phase Modulation

7 = Quantized/Digital Info

D = Data transmission; telemetry; telecommand

16QAM Modulation

5MHz Bandwidth

Emission Designator = 4M48W7D

LTE BW = 4.48 MHz

W = main carrier modulated in a combination of two or more of the following modes;
amplitude, angle, pulse

7 = Quantized/Digital Info

D = Data transmission; telemetry; telecommand

10MHz Bandwidth

Emission Designator = 8M95W7D

LTE BW = 8.95 MHz

W = main carrier modulated in a combination of two or more of the following modes;
amplitude, angle, pulse

7 = Quantized/Digital Info

D = Data transmission; telemetry; telecommand

7. TEST DATA

7.1 EFFECTIVE RADIATED POWER (Band 26)

Freq (MHz)	Bandwidth	Modulation	Measured Level (dBm)	Substitute Level (dBm)	Ant. Gain(dBd)	C.L	Pol	ERP	
								W	dBm
814.7	1.4 MHz	QPSK	-29.99	31.91	-10.25	0.87	V	0.120	20.79
		16-QAM	-30.84	31.06	-10.25	0.87	V	0.099	19.94
823.3		QPSK	-31.45	30.22	-10.23	0.88	V	0.081	19.11
		16-QAM	-32.18	29.49	-10.23	0.88	V	0.069	18.38

Effective Radiated Power Data (1.4 MHz Band 26 LTE)

Note: All of RB size has been tested for emissions and ERP, with the 1RB configuration observed as the worst case

Freq (MHz)	Bandwidth	Modulation	Measured Level (dBm)	Substitute Level (dBm)	Ant. Gain(dBd)	C.L	Pol	ERP	
								W	dBm
815.5	3 MHz	QPSK	-29.80	32.02	-10.25	0.87	V	0.123	20.90
		16-QAM	-30.52	31.30	-10.25	0.87	V	0.104	20.18
822.5		QPSK	-29.96	31.75	-10.23	0.88	V	0.116	20.64
		16-QAM	-30.66	31.05	-10.23	0.88	V	0.099	19.94

Effective Radiated Power Data (3 MHz Band 26 LTE)

Note: All of RB size has been tested for emissions and ERP, with the 1RB configuration observed as the worst case

Freq (MHz)	Bandwidth	Modulation	Measured Level (dBm)	Substitute Level (dBm)	Ant. Gain(dBd)	C.L	Pol	ERP	
								W	dBm
816.5	5 MHz	QPSK	-29.78	32.01	-10.24	0.87	V	0.123	20.90
		16-QAM	-30.66	31.13	-10.24	0.87	V	0.100	20.02
821.5		QPSK	-29.03	32.75	-10.23	0.88	V	0.146	21.64
		16-QAM	-29.58	32.20	-10.23	0.88	V	0.128	21.09

Effective Radiated Power Data (5 MHz Band 26 LTE)

Note: All of RB size has been tested for emissions and ERP, with the 1RB configuration observed as the worst case

Freq (MHz)	Bandwidth	Modulation	Measured Level (dBm)	Substitute Level (dBm)	Ant. Gain(dBd)	C.L	Pol	ERP	
								W	dBm
819.0	10 MHz	QPSK	-29.55	32.25	-10.24	0.87	V	0.130	21.14
		16-QAM	-30.27	31.53	-10.24	0.87	V	0.110	20.42

Effective Radiated Power Data (10 MHz Band 26 LTE)

Note: All of RB size has been tested for emissions and ERP, with the 1RB configuration observed as the worst case

NOTES:

Effective Radiated Power Output Measurements by Substitution Method

according to ANSI/TIA/EIA-603-D-2010 June 24, 2010:

The EUT was placed on a non-conductive styrofoam resin table 3-meters from the receive antenna. The receive antenna height and turntable rotation was adjusted for the highest reading on the receive spectrum analyzer. For LTE signals, RBW = 1-5% of the OBW, not to exceed 1MHz, VBW $\geq 3 \times$ RBW, Detector = RMS. A half-wave dipole was substituted in place of the EUT. This dipole antenna was driven by a signal generator and the level of the signal generator was adjusted to obtain the same receive spectrum analyzer reading. The conducted power at the terminals of the dipole is measured. The ERP is recorded.

Also, we have done x, y, z planes in EUT and horizontal and vertical polarization in detecting antenna. The worst case of the EUT is y plane in LTE mode. Also worst case of detecting Antenna is vertical polarization in LTE mode.

7.2 RADIATED SPURIOUS EMISSIONS

7.2.1 RADIATED SPURIOUS EMISSIONS (1.4 MHz Band 26 LTE)

- ▣ OPERATING FREQUENCY: 814.70 MHz
- ▣ MEASURED OUTPUT POWER: 20.79 dBm = 0.120 W
- ▣ MODULATION SIGNAL: 1.4 MHz QPSK
- ▣ DISTANCE: 3 meters
- ▣ LIMIT: $43 + 10 \log_{10}(W) =$ 33.79 dBc

Ch	Freq (MHz)	Measured Level (dBm)	Ant. Gain (dBd)	Substitute Level (dBm)	C.L	Pol	ERP (dBm)	dBc
26697 (814.7)	1,629.40	-44.35	9.09	-56.67	1.38	V	-48.96	69.75
	2,444.10	-47.11	10.89	-55.79	1.69	V	-46.59	67.38
	3,258.80	-53.81	11.85	-60.78	1.91	H	-50.84	71.63
26783 (823.3)	1,646.60	-39.89	9.15	-52.26	1.38	V	-44.49	65.28
	2,469.90	-46.68	10.92	-55.42	1.69	H	-46.19	66.98
	3,293.20	-51.63	11.93	-58.87	1.99	V	-48.93	69.72

- NOTES:**
1. Radiated Spurious Emission Measurements at 3 meters by Substitution Method according to ANSI/TIA/EIA-603-D-2010 June 24, 2010:
 2. We are performed all frequency to 10th harmonics from 30 MHz. Measurements above show only up to 3 maximum emissions noted, or would be lesser if no specific emissions from the EUT are recorded (ie: margin > 20 dB from the applicable limit) and considered that's already beyond the background noise floor.
 3. we have done x, y, z planes in EUT and horizontal and vertical polarization in detecting antenna.
 4. All of RB size has been tested for emissions and ERP, with the 1RB configuration observed as the worst case
 5. We are performed 16QAM and QPSK modulations. The worst case data are reported in the table above.

7.2.2 RADIATED SPURIOUS EMISSIONS (3 MHz Band 26 LTE)

- ▣ OPERATING FREQUENCY: 815.50 MHz
- ▣ MEASURED OUTPUT POWER: 20.90 dBm = 0.123 W
- ▣ MODULATION SIGNAL: 3 MHz QPSK
- ▣ DISTANCE: 3 meters
- ▣ LIMIT: $43 + 10 \log_{10}(W) =$ 33.90 dBc

Ch	Freq (MHz)	Measured Level (dBm)	Ant. Gain (dBd)	Substitute Level (dBm)	C.L	Pol	ERP (dBm)	dBc
26705 (815.5)	1,631.00	-45.23	9.09	-57.59	1.38	V	-49.88	70.78
	2,446.50	-45.91	10.90	-54.69	1.68	V	-45.47	66.37
	3,262.00	-53.61	11.86	-60.56	1.92	H	-50.62	71.52
26775 (822.5)	1,645.00	-40.51	9.14	-52.93	1.39	V	-45.18	66.08
	2,467.50	-48.59	10.92	-57.32	1.69	V	-48.09	68.99
	3,290.00	-49.88	11.92	-57.12	1.99	H	-47.19	68.09

- NOTES:**
1. Radiated Spurious Emission Measurements at 3 meters by Substitution Method according to ANSI/TIA/EIA-603-D-2010 June 24, 2010:
 2. We are performed all frequency to 10th harmonics from 30 MHz. Measurements above show only up to 3 maximum emissions noted, or would be lesser if no specific emissions from the EUT are recorded (ie: margin > 20 dB from the applicable limit) and considered that's already beyond the background noise floor.
 3. we have done x, y, z planes in EUT and horizontal and vertical polarization in detecting antenna.
 4. All of RB size has been tested for emissions and ERP, with the 1RB configuration observed as the worst case
 5. We are performed 16QAM and QPSK modulations. The worst case data are reported in the table above.

7.2.3 RADIATED SPURIOUS EMISSIONS (5 MHz Band 26 LTE)

- ▣ OPERATING FREQUENCY: 821.50 MHz
- ▣ MEASURED OUTPUT POWER: 21.64 dBm = 0.146 W
- ▣ MODULATION SIGNAL: 5 MHz QPSK
- ▣ DISTANCE: 3 meters
- ▣ LIMIT: $43 + 10 \log_{10}(W) =$ 34.64 dBc

Ch	Freq (MHz)	Measured Level (dBm)	Ant. Gain (dBd)	Substitute Level (dBm)	C.L	Pol	ERP (dBm)	dBc
26715 (816.5)	1,633.00	-44.76	9.10	-57.18	1.38	H	-49.46	71.10
	2,449.50	-46.13	10.90	-55.01	1.68	V	-45.79	67.43
	3,266.00	-54.28	11.87	-61.24	1.93	V	-51.30	72.94
26765 (821.5)	1,643.00	-41.88	9.13	-54.38	1.39	V	-46.64	68.28
	2,464.50	-47.59	10.91	-56.29	1.69	H	-47.07	68.71
	3,286.00	-52.68	11.91	-59.90	1.96	H	-49.95	71.59

- NOTES:**
1. Radiated Spurious Emission Measurements at 3 meters by Substitution Method according to ANSI/TIA/EIA-603-D-2010 June 24, 2010:
 2. We are performed all frequency to 10th harmonics from 30 MHz. Measurements above show only up to 3 maximum emissions noted, or would be lesser if no specific emissions from the EUT are recorded (ie: margin > 20 dB from the applicable limit) and considered that's already beyond the background noise floor.
 3. we have done x, y, z planes in EUT and horizontal and vertical polarization in detecting antenna.
 4. All of RB size has been tested for emissions and ERP, with the 1RB configuration observed as the worst case
 5. We are performed 16QAM and QPSK modulations. The worst case data are reported in the table above.

7.2.4 RADIATED SPURIOUS EMISSIONS (10 MHz Band 26 LTE)

- ▣ OPERATING FREQUENCY: 819.00 MHz
- ▣ MEASURED OUTPUT POWER: 21.14 dBm = 0.130 W
- ▣ MODULATION SIGNAL: 10 MHz QPSK
- ▣ DISTANCE: 3 meters
- ▣ LIMIT: $43 + 10 \log_{10}(W) =$ 34.14 dBc

Ch	Freq (MHz)	Measured Level (dBm)	Ant. Gain (dBd)	Substitute Level (dBm)	C.L	Pol	ERP (dBm)	dBc
26740 (819.0)	1,638.00	-44.47	9.11	-57.03	1.39	H	-49.31	70.45
	2,457.00	-47.75	10.91	-56.50	1.69	H	-47.28	68.42
	3,276.00	-54.05	11.89	-61.17	1.92	H	-51.20	72.34

- NOTES:**
1. Radiated Spurious Emission Measurements at 3 meters by Substitution Method according to ANSI/TIA/EIA-603-D-2010 June 24, 2010:
 2. We are performed all frequency to 10th harmonics from 30 MHz. Measurements above show only up to 3 maximum emissions noted, or would be lesser if no specific emissions from the EUT are recorded (ie: margin > 20 dB from the applicable limit) and considered that's already beyond the background noise floor.
 3. we have done x, y, z planes in EUT and horizontal and vertical polarization in detecting antenna.
 4. All of RB size has been tested for emissions and ERP, with the 1RB configuration observed as the worst case
 5. We are performed 16QAM and QPSK modulations. The worst case data are reported in the table above.

7.3 OCCUPIED BANDWIDTH

Band	Band Width	Frequency (MHz)	Modulation	Resource Block Size	Resource Block Offset	Data (MHz)
Band 26	1.4 MHz	814.7	QPSK	6	0	1.0838
			16-QAM			1.0829
		823.3	QPSK			1.0870
			16-QAM			1.0839
	3 MHz	815.5	QPSK	15		2.6843
			16-QAM			2.6784
		822.5	QPSK			2.6851
			16-QAM			2.6842
	5 MHz	816.5	QPSK	25		4.4709
			16-QAM			4.4752
		821.5	QPSK			4.4745
			16-QAM			4.4805
	10 MHz	819.0	QPSK	50		8.9654
			16-QAM			8.9448

- Plots of the EUT's Occupied Bandwidth are shown Page 23 ~ 29.

7.4 CONDUCTED SPURIOUS EMISSIONS

Band	Band Width (MHz)	Frequency (MHz)	Modulation	Resource Block Size	Resource Block Offset	Frequency of Maximum Harmonic (GHz)	Maximum Data [dBm]
Band 26	1.4	814.7	QPSK	1	0	9.368000	-32.462
		823.3				2.695908	-31.791
	3	815.5				7.240000	-32.235
		822.5				3.144699	-31.589
	5	816.5				3.168058	-32.187
		821.5				10.000000	-32.120
	10	819.0				2.702369	-31.779

- Plots of the EUT's Conducted Spurious Emissions are shown Page 33 ~ 40.

7.4.1 BAND EDGE

- Plots of the EUT's Band Edge are shown Page 30 ~ 33.

7.8 FREQUENCY STABILITY / VARIATION OF AMBIENT TEMPERATURE

7.8.1 FREQUENCY STABILITY (3 MHz Band 26 LTE)

- ▣ OPERATING FREQUENCY: 815,500,000 Hz
- ▣ CHANNEL: 23705(3 MHz)
- ▣ REFERENCE VOLTAGE: 4.00 VDC
- ▣ DEVIATION LIMIT: ± 0.000 25 % or 2.5 ppm

Voltage (%)	Power (VDC)	Temp. (°C)	Frequency (Hz)	Frequency Error (Hz)	Deviation (%)	ppm
100%	4.00	+20(Ref)	815 499 994	0.0	0.000 000	0.000
100%		-30	815 499 986	-8.4	-0.000 001	-0.010
100%		-20	815 499 983	-11.3	-0.000 001	-0.014
100%		-10	815 499 988	-6.3	-0.000 001	-0.008
100%		0	815 499 982	-12.8	-0.000 002	-0.016
100%		+10	815 499 984	-10.3	-0.000 001	-0.013
100%		+30	815 499 986	-8.1	-0.000 001	-0.010
100%		+40	815 499 987	-7.3	-0.000 001	-0.009
100%		+50	815 500 002	7.9	0.000 001	0.010
Batt. Endpoint	3.75	+20	815 499 978	-16.4	-0.000 002	-0.020

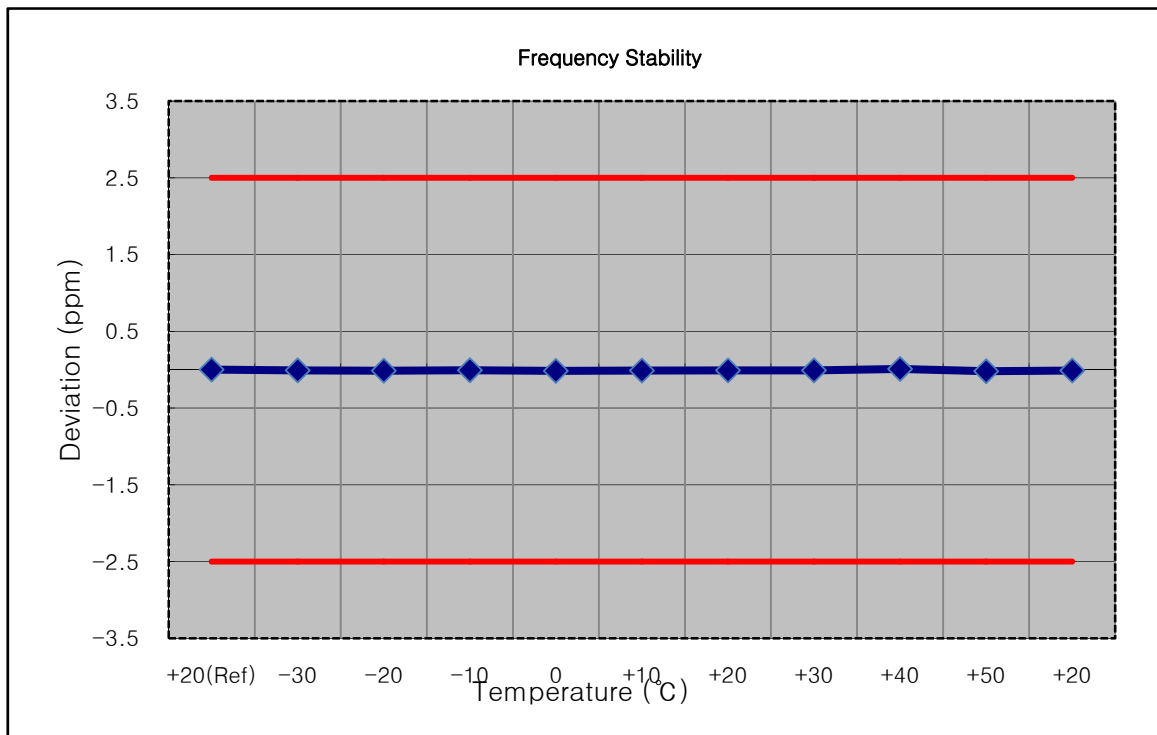

8. TEST PLOTS

BAND 26. Occupied Bandwidth Plot (1.4M BW Ch.26697 QPSK RB 6_0)

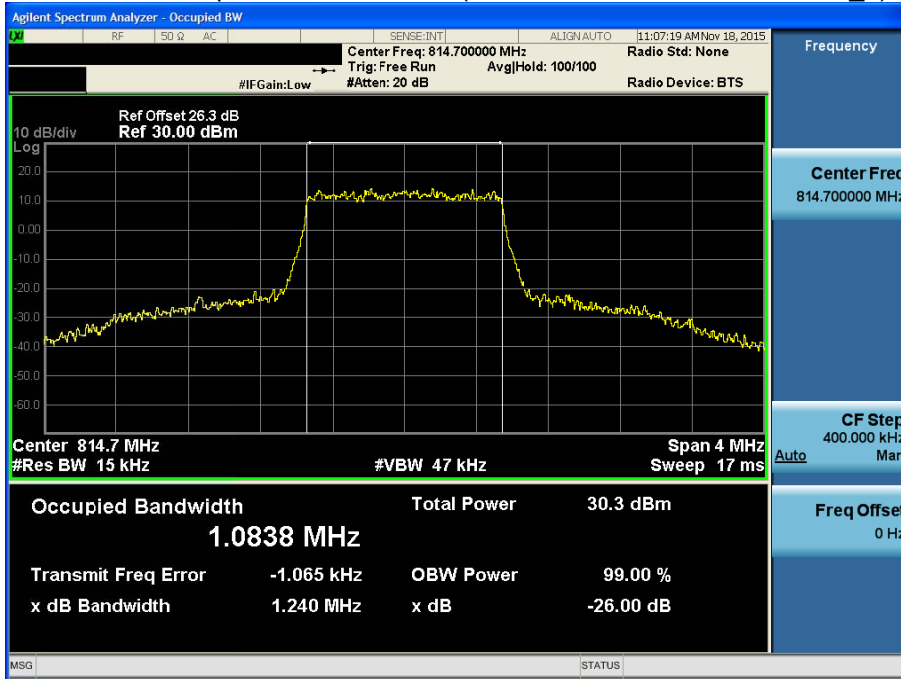

BAND 26. Occupied Bandwidth Plot (1.4M BW Ch.26697 16QAM RB 6_0)

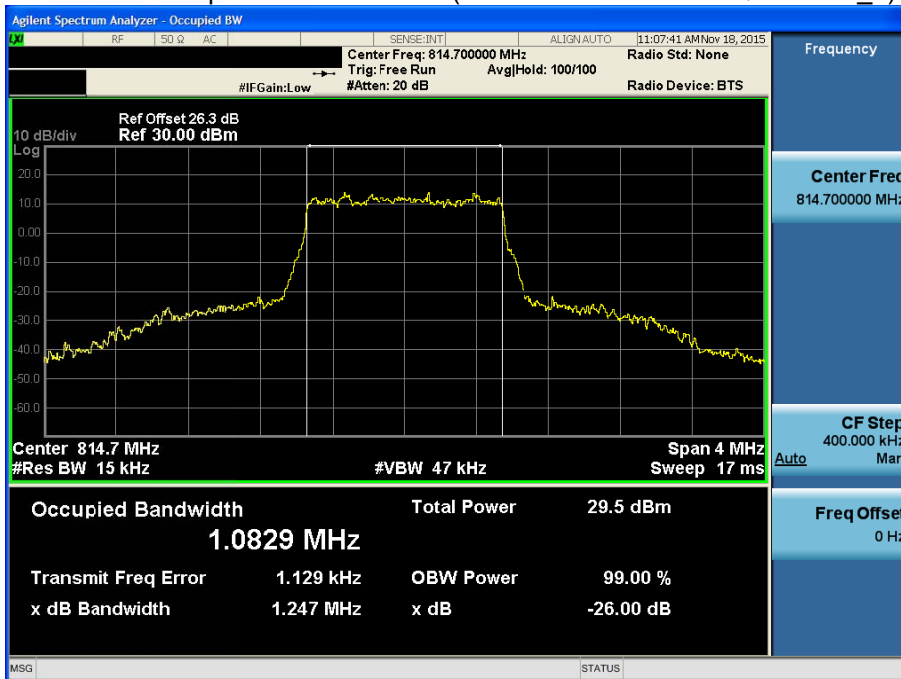

BAND 26. Occupied Bandwidth Plot (1.4M BW Ch.26783 QPSK RB 6_0)

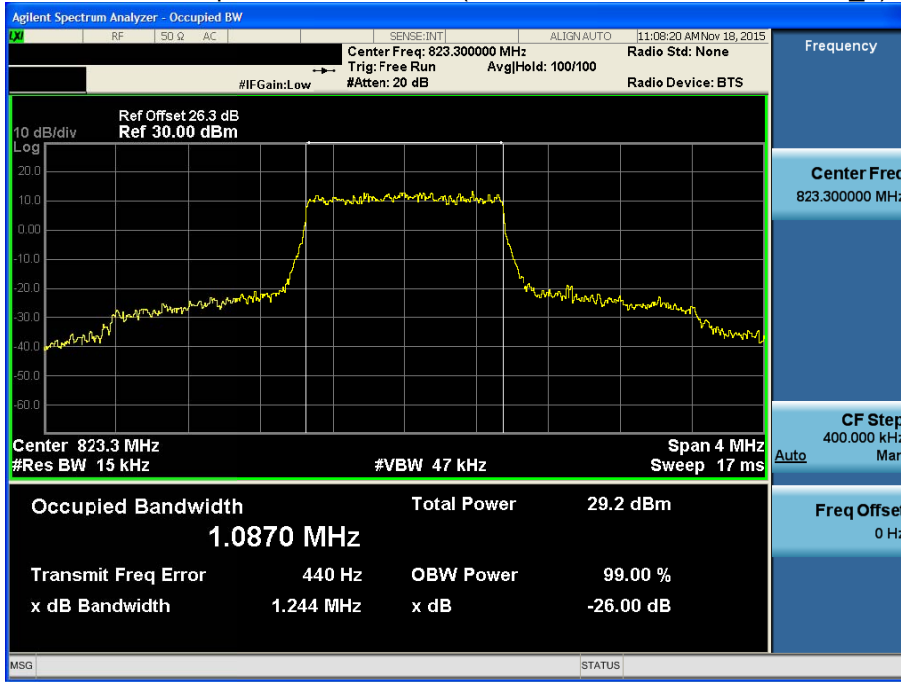

BAND 26. Occupied Bandwidth Plot (1.4M BW Ch.26783 16QAM RB 6_0)

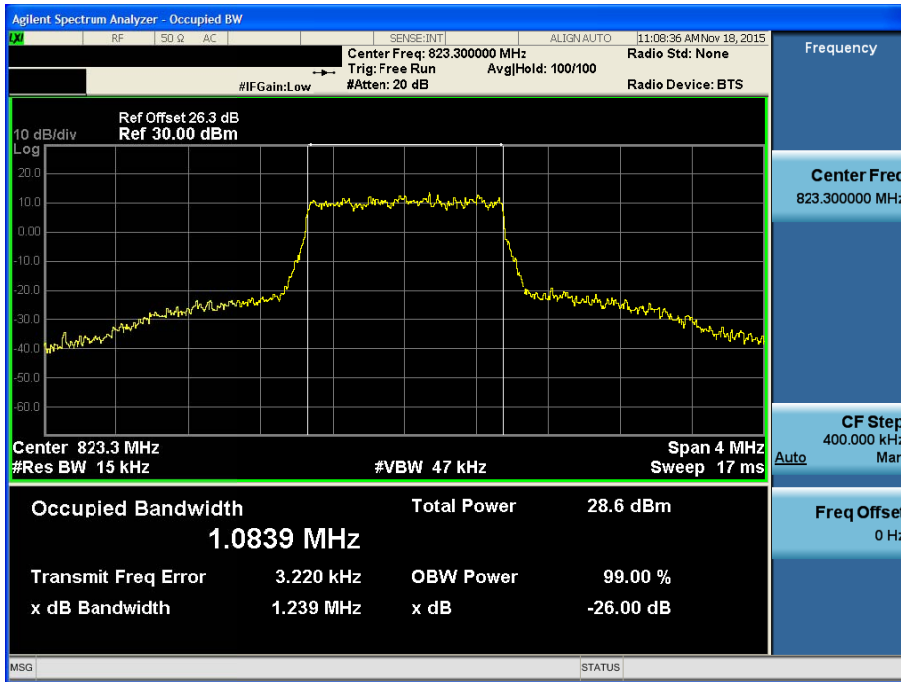

BAND 26. Occupied Bandwidth Plot (3M BW Ch.26705 QPSK RB 15_0)

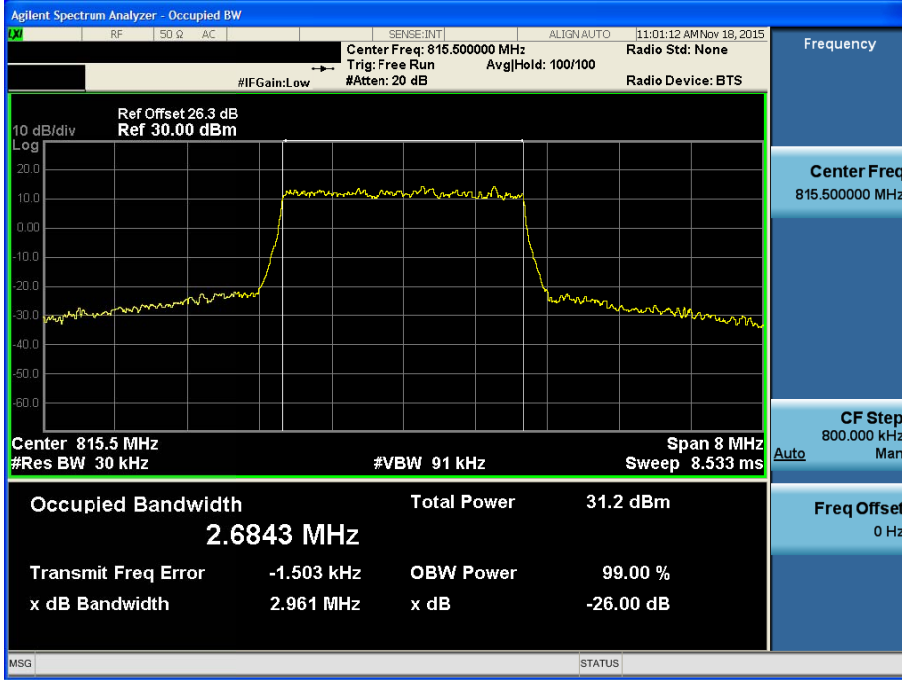

BAND 26. Occupied Bandwidth Plot (3M BW Ch.26705 16QAM RB 15_0)

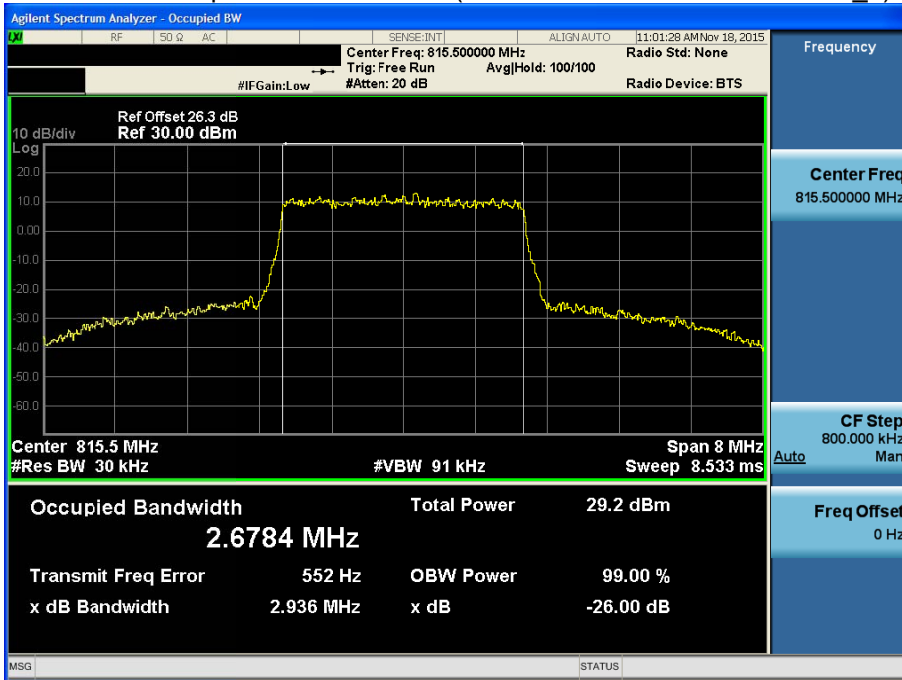

BAND 26. Occupied Bandwidth Plot (3M BW Ch.26775 QPSK RB 15_0)

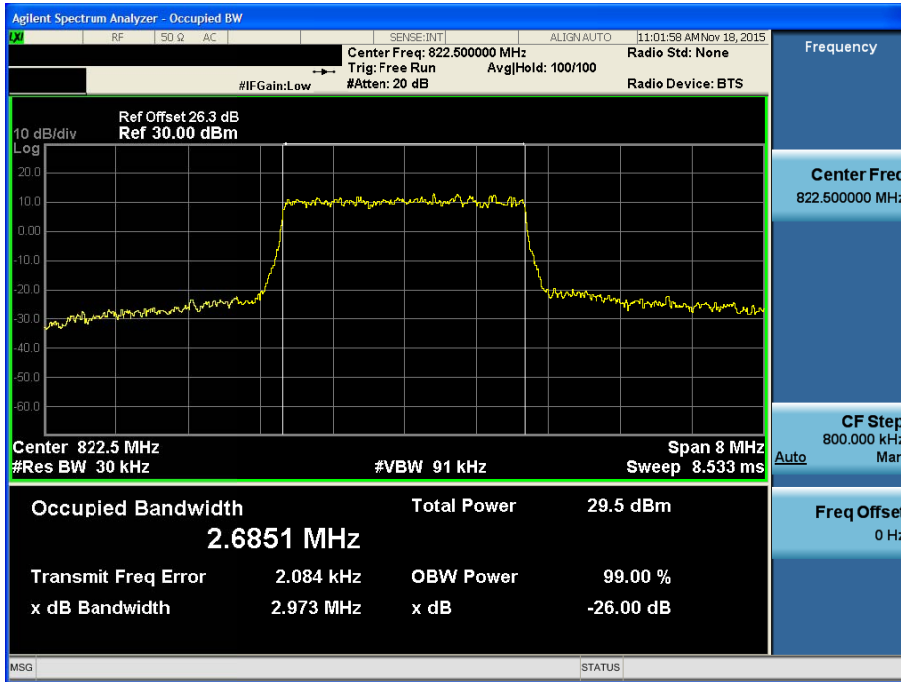

BAND 26. Occupied Bandwidth Plot (3M BW Ch.26775 16QAM RB 15_0)

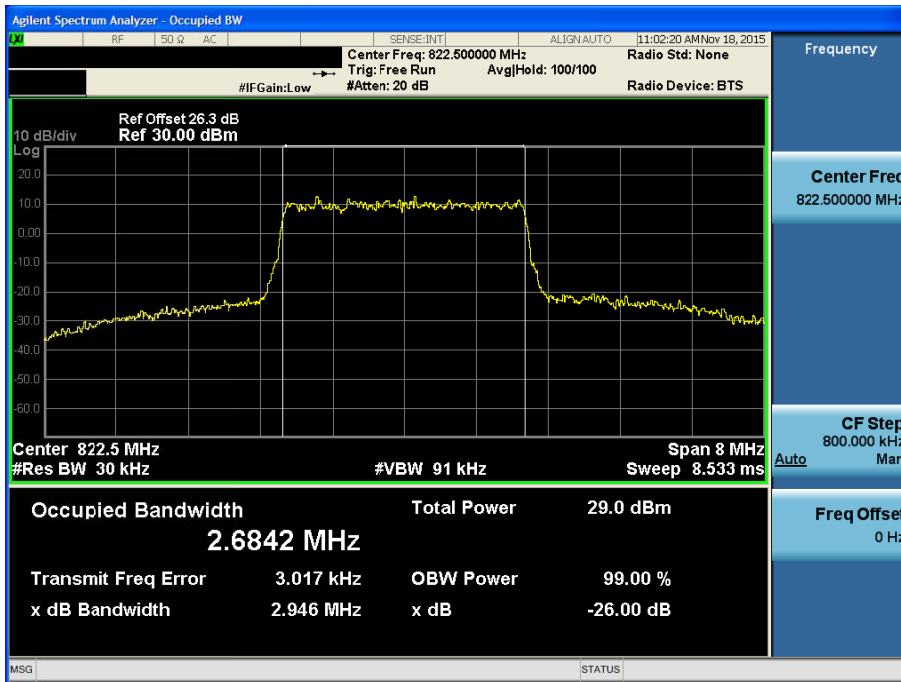

BAND 26. Occupied Bandwidth Plot (5M BW Ch.26715 QPSK RB 25_0)

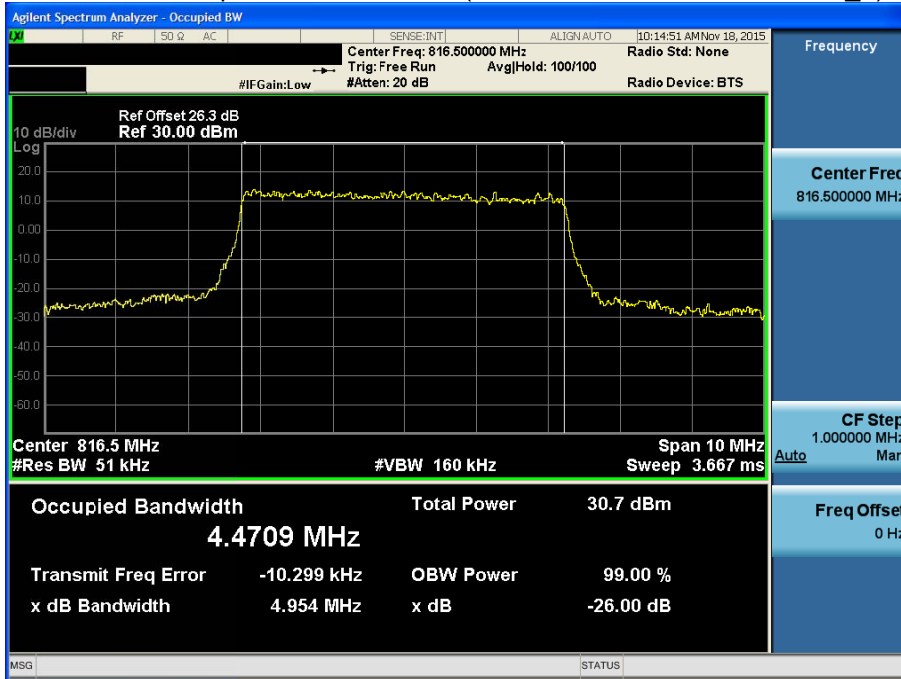

BAND 26. Occupied Bandwidth Plot (5M BW Ch.26715 16QAM RB 25_0)

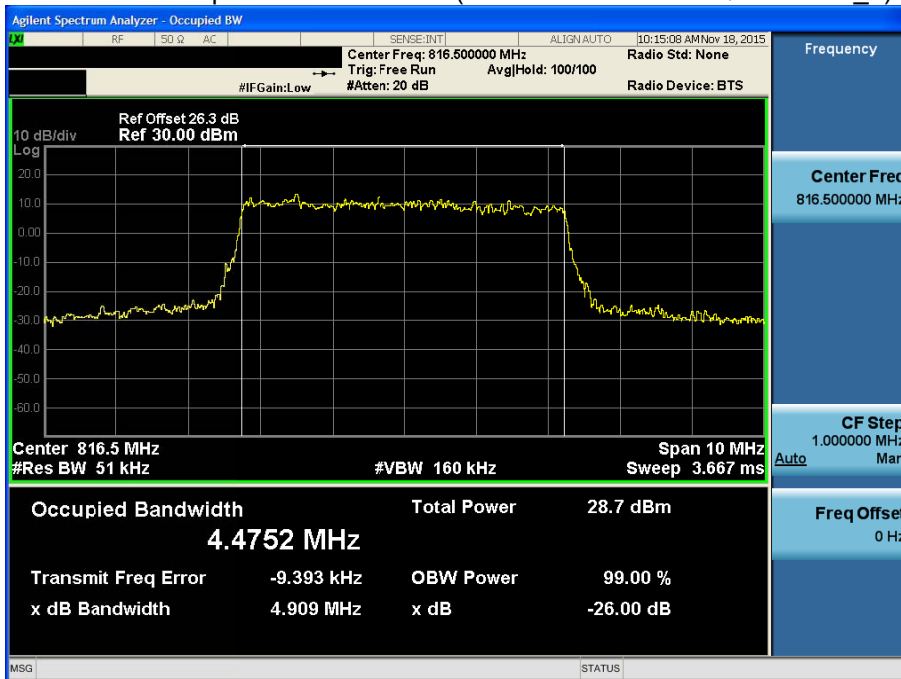

BAND 26. Occupied Bandwidth Plot (5M BW Ch.26765 QPSK RB 25_0)

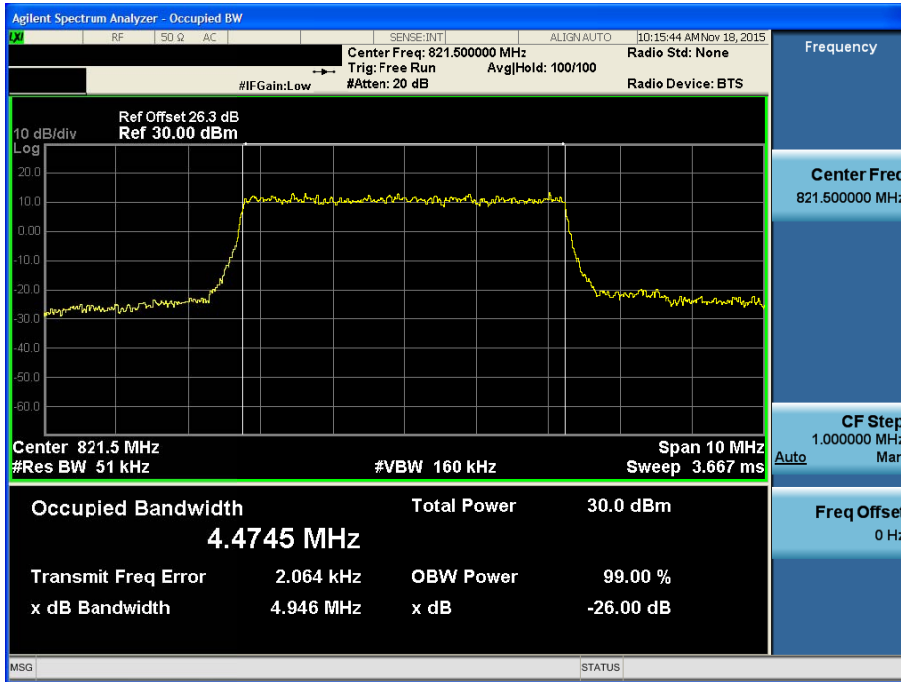

BAND 26. Occupied Bandwidth Plot (5M BW Ch.26756 16QAM RB 25_0)

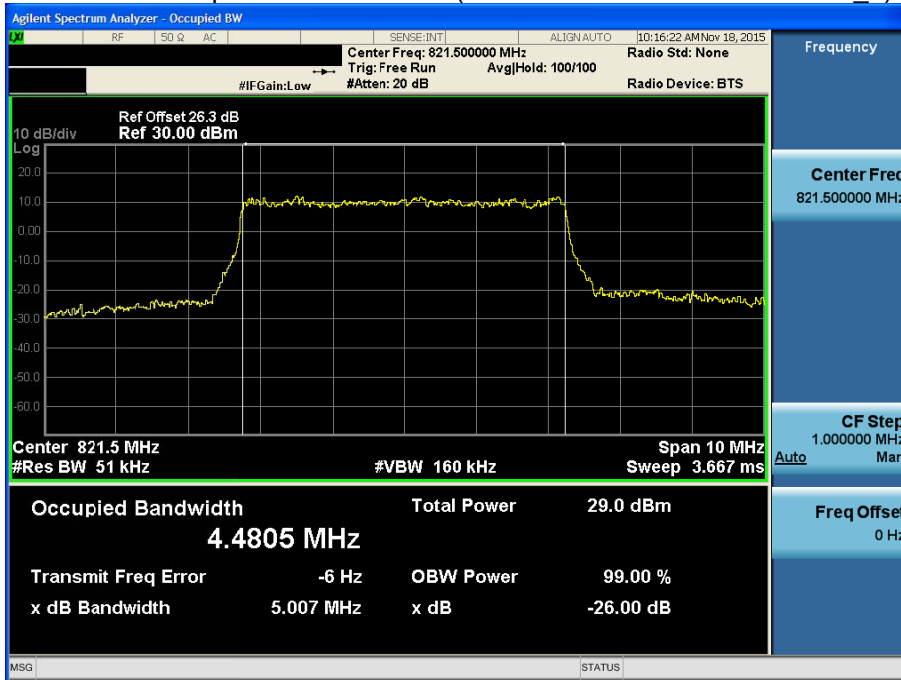

BAND 26. Occupied Bandwidth Plot (10M BW Ch.26740 QPSK RB 50_0)

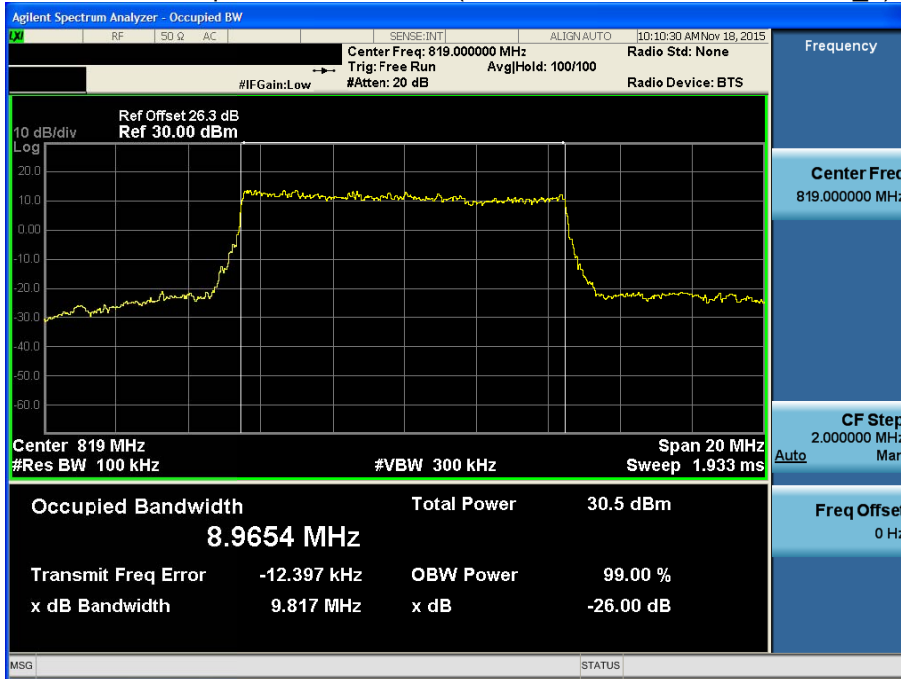

BAND 26. Occupied Bandwidth Plot (10M BW Ch.26740 16QAM RB 50_0)

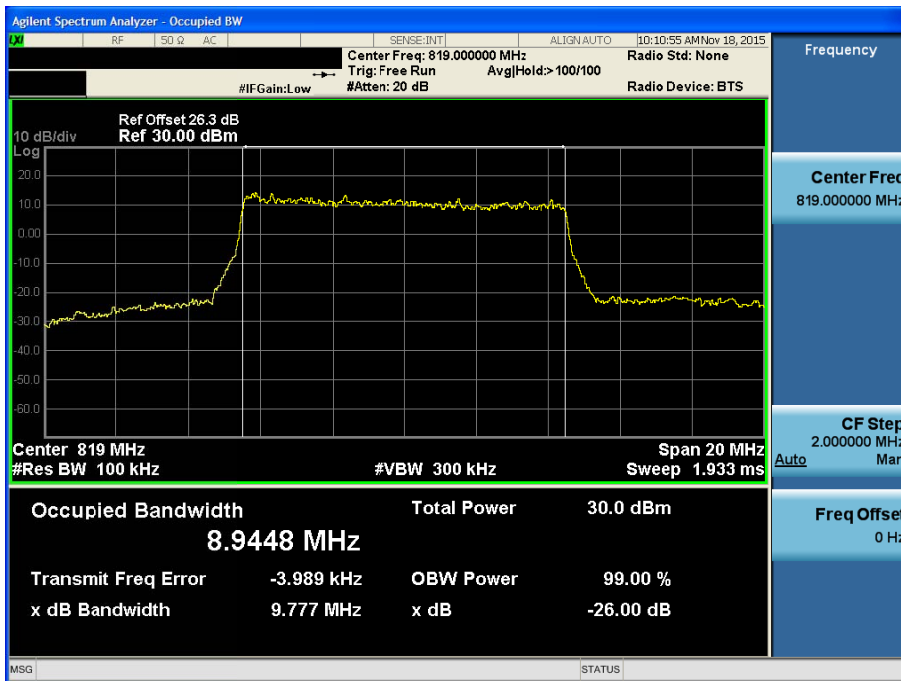

BAND 26. Low Channel Edge Plot (1.4M BW Ch.26697 QPSK_RB1_Offset 0) -1

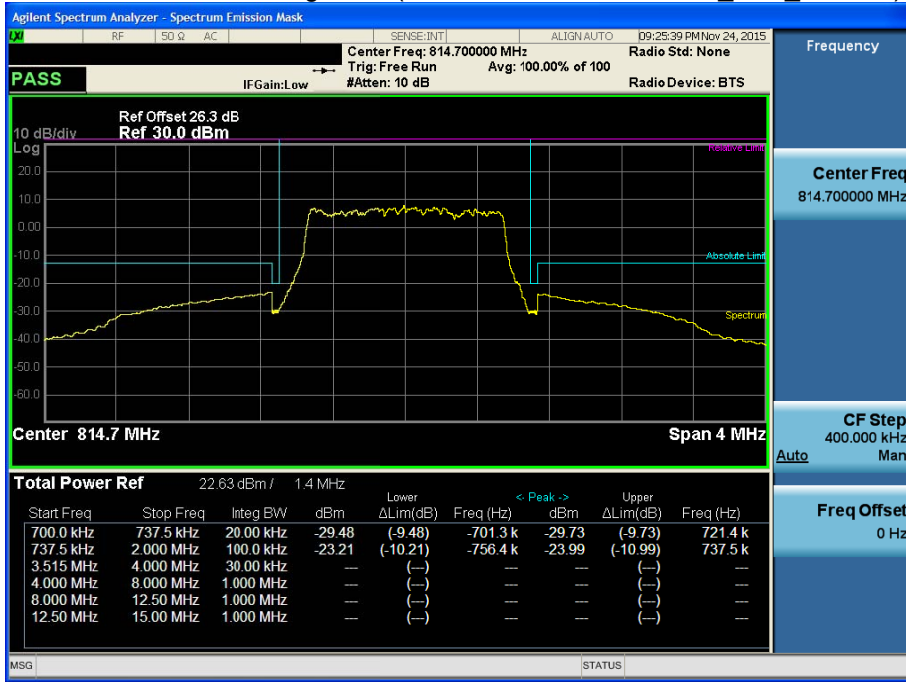

BAND 26. High Channel Edge Plot (1.4M BW Ch.26783 QPSK_RB6_Offset 0) -2

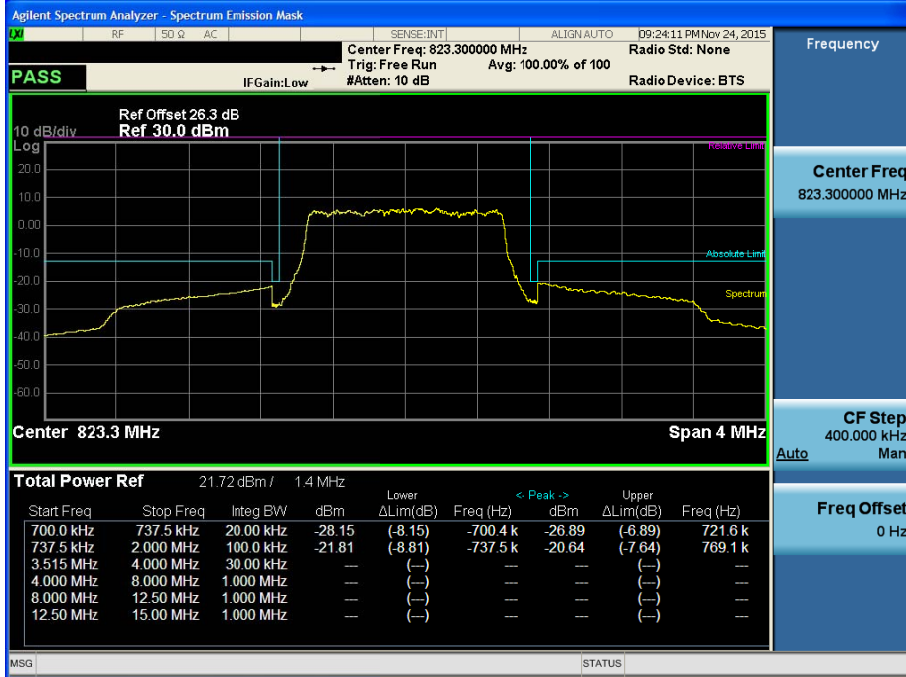

BAND 26. Low Channel Edge Plot (3M BW Ch.26705 QPSK_RB1_Offset 0) -1

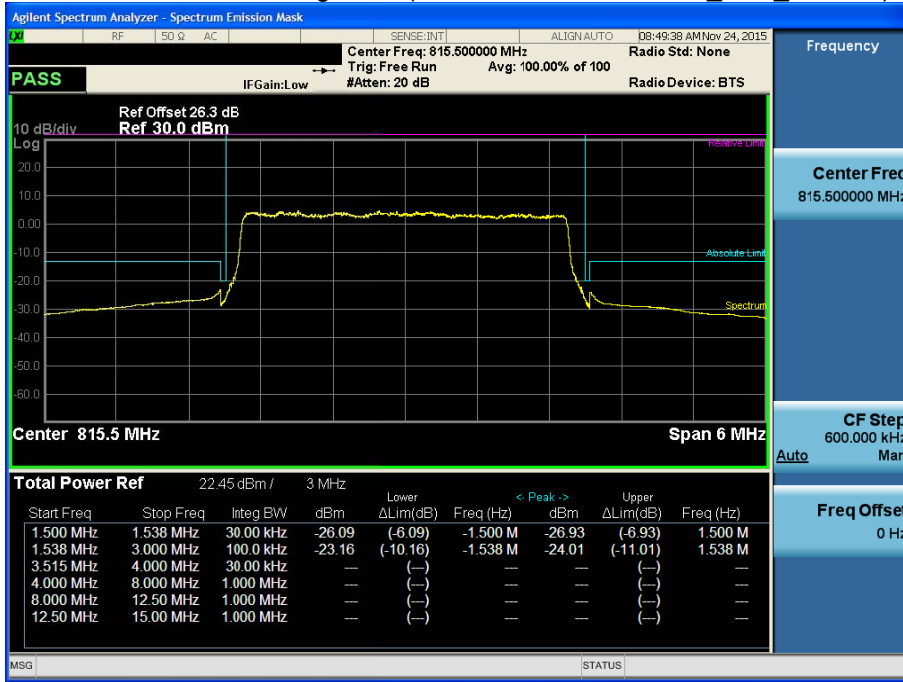

BAND 26. High Channel Edge Plot (3M BW Ch. 26775 QPSK_RB15_Offset 0) -2

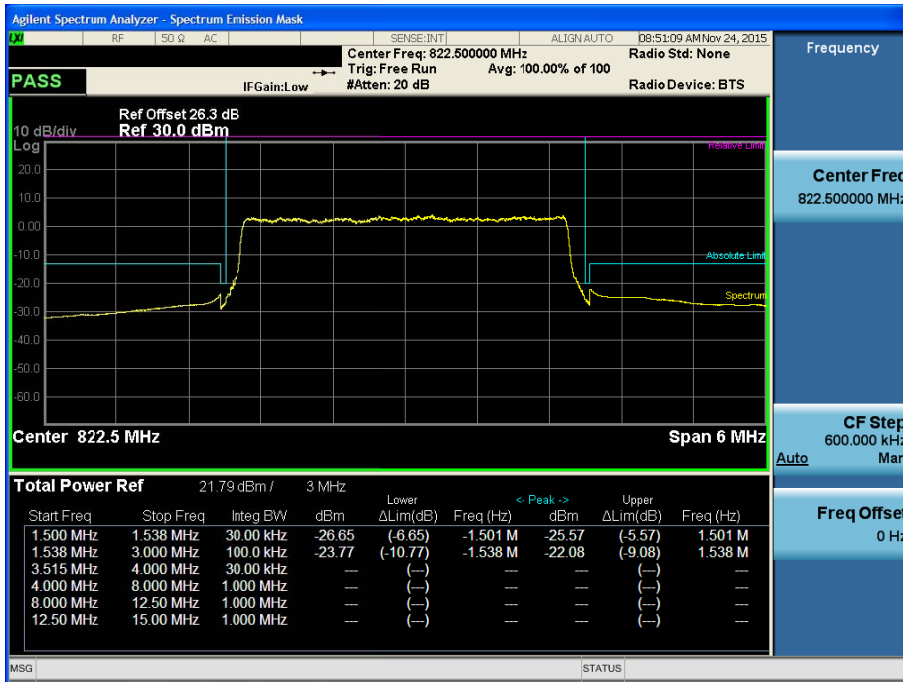

BAND 26. Low Channel Edge Plot (5M BW Ch.26715 QPSK_RB1_Offset 0) -1

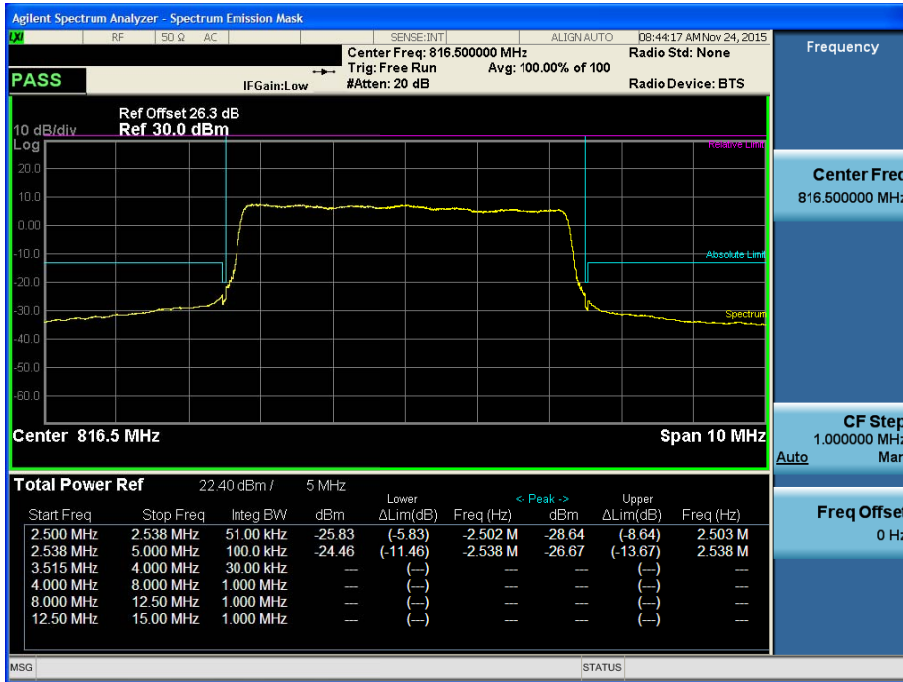

BAND 26. High Channel Edge Plot (5M BW Ch. 26765 QPSK_RB25_Offset 0) -2

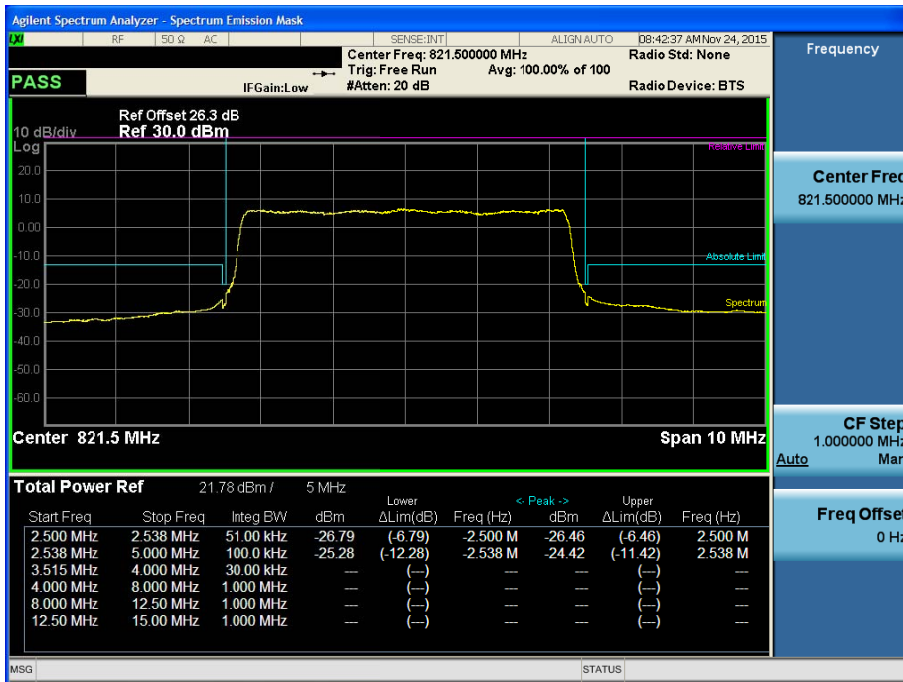

BAND 26. Low Channel Edge Plot (10M BW Ch.26740 QPSK_RB1_Offset 0) -1

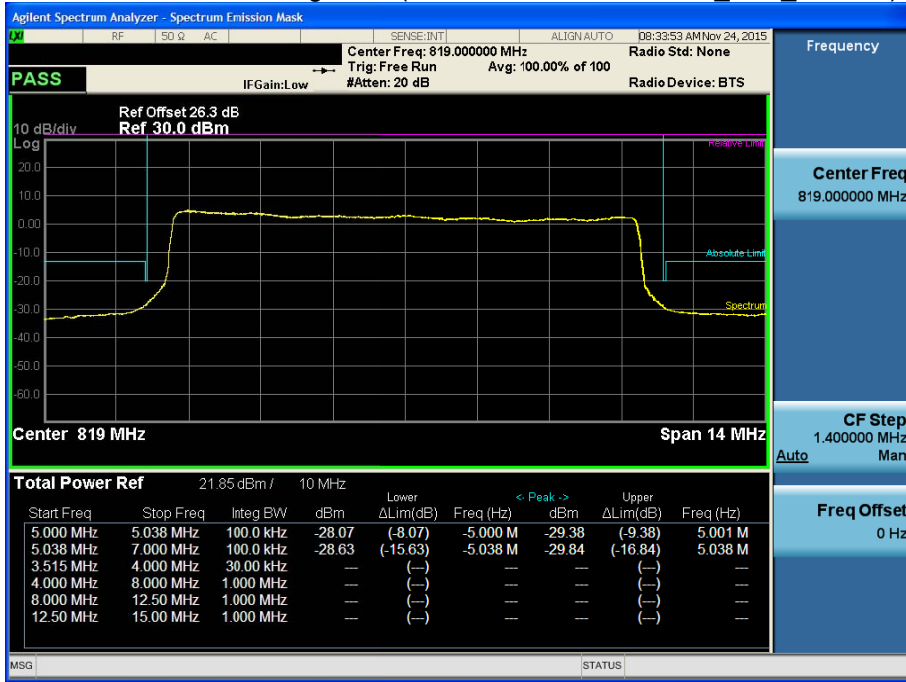

BAND 26. Conducted Spurious_1 (26697 ch_1.4MHz_QPSK_RB 1_0)

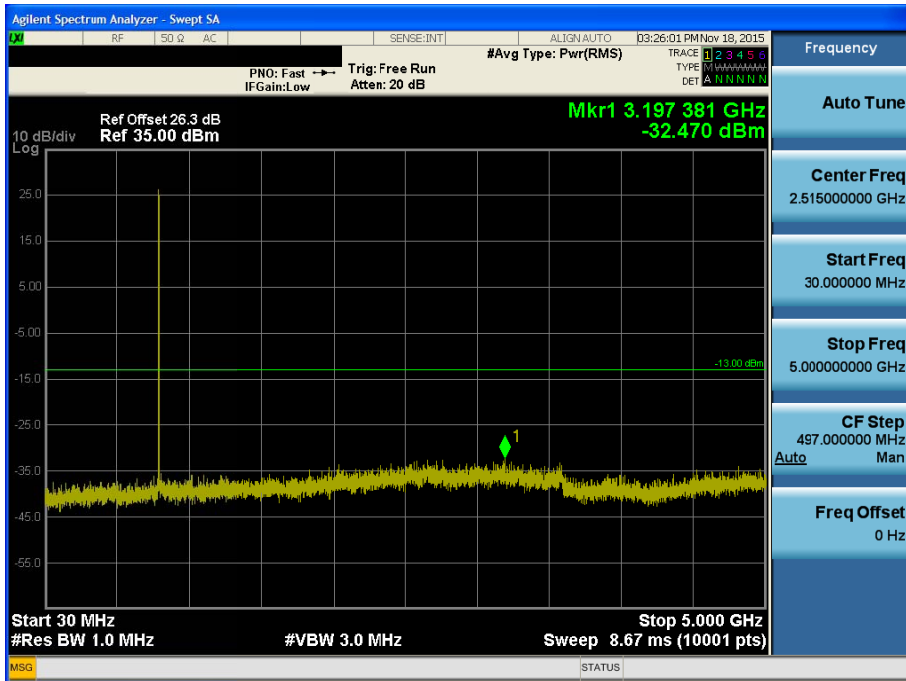

BAND 26. Conducted Spurious_2 (26783 ch_1.4MHz_QPSK_RB 1_0)

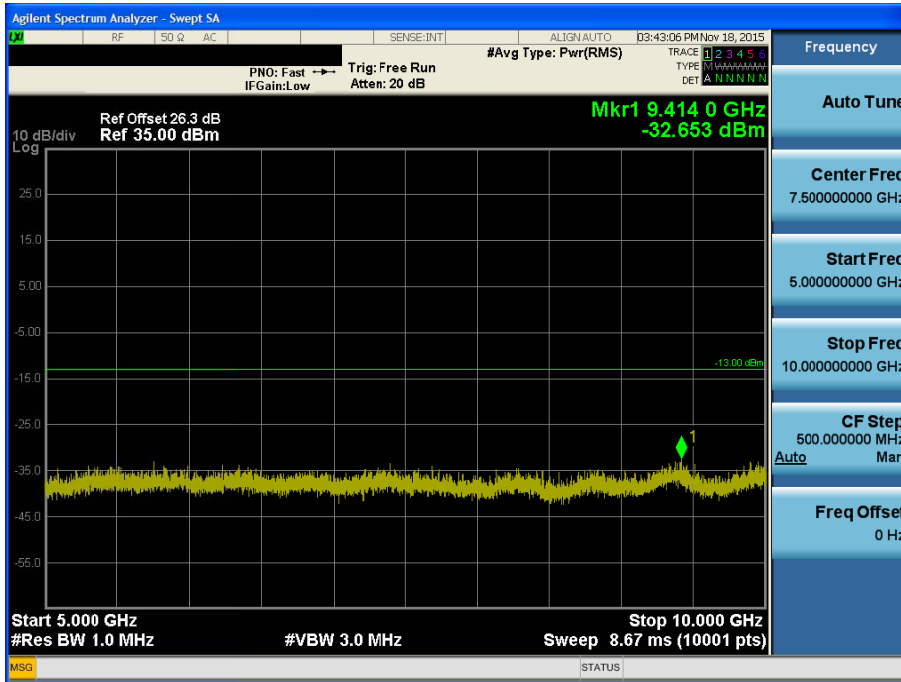

BAND 26. Conducted Spurious_1 (26705 ch_3MHz_QPSK_RB 1_0)

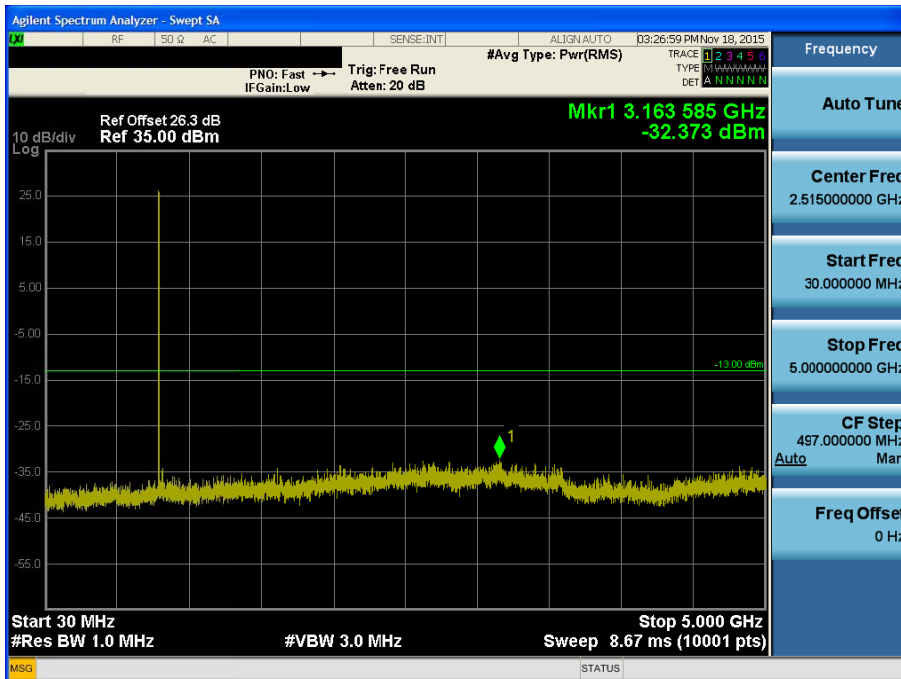

BAND 26. Conducted Spurious_2 (26705 ch_3MHz_QPSK_RB 1_0)

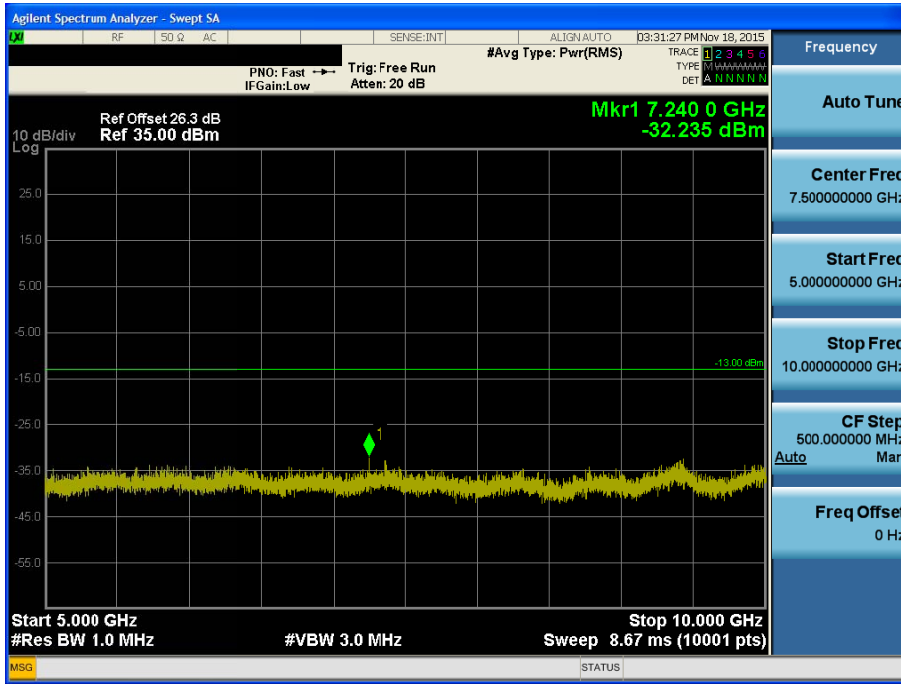

BAND 26. Conducted Spurious_1 (26775 ch_3MHz_QPSK_RB 1_0)

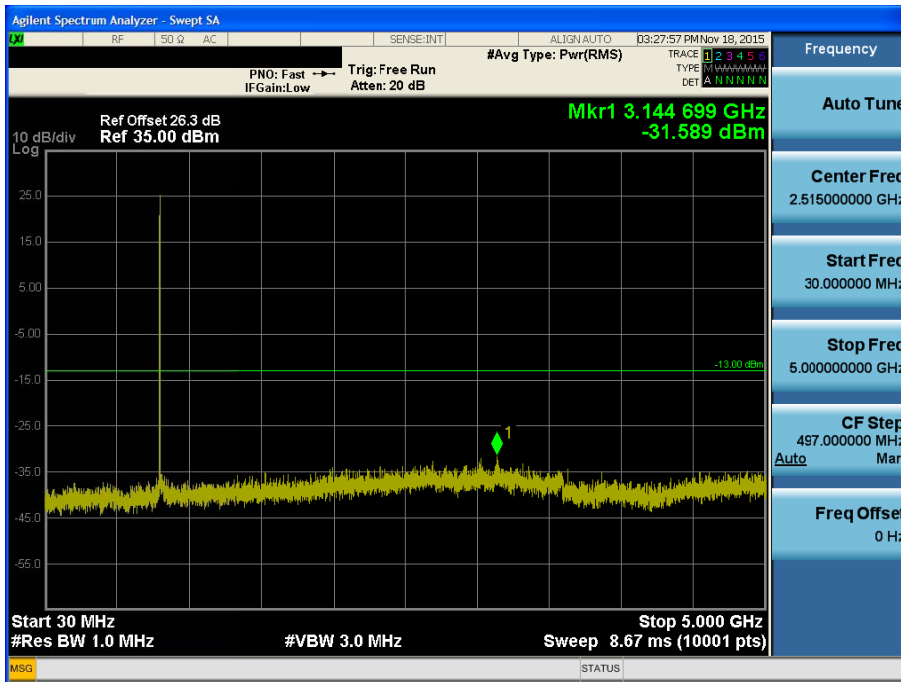

BAND 26. Conducted Spurious_2 (26715 ch_5MHz_QPSK_RB 1_0)

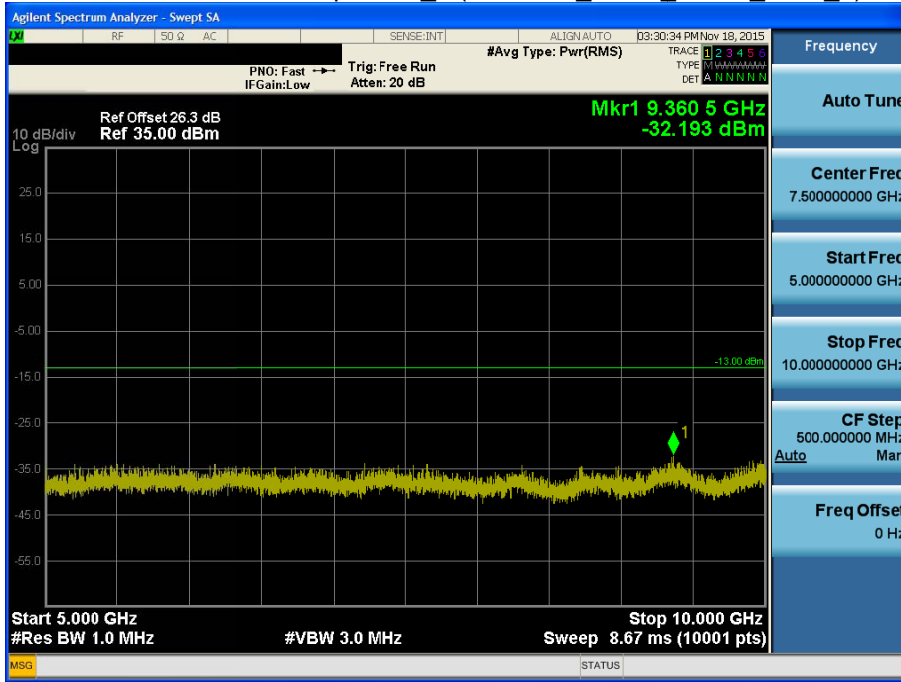

BAND 26. Conducted Spurious_1 (26765 ch_5MHz_QPSK_RB 1_0)

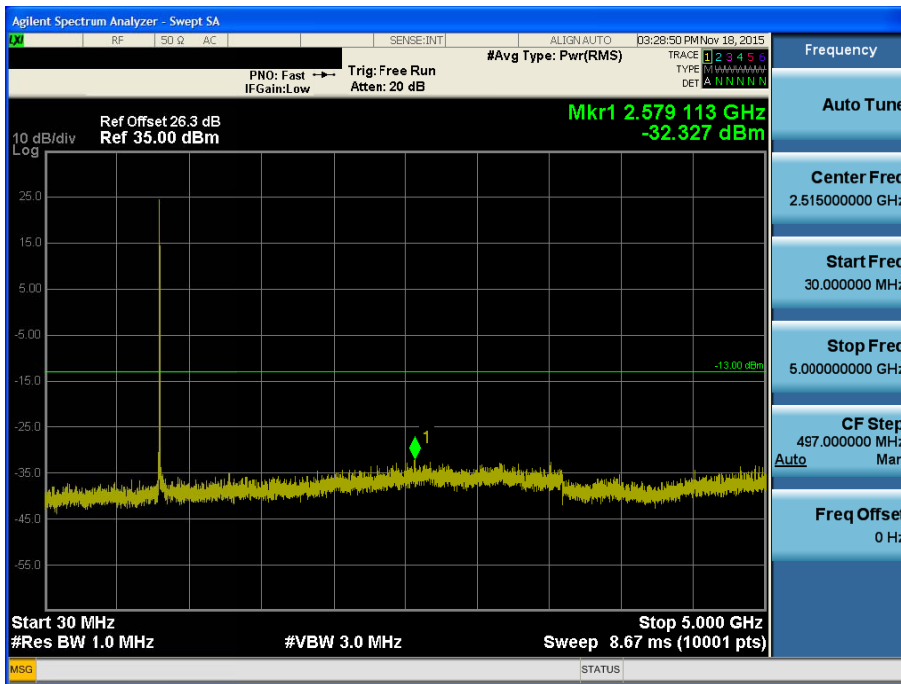

BAND 26. Conducted Spurious_2 (26765 ch_5MHz_QPSK_RB 1_0)

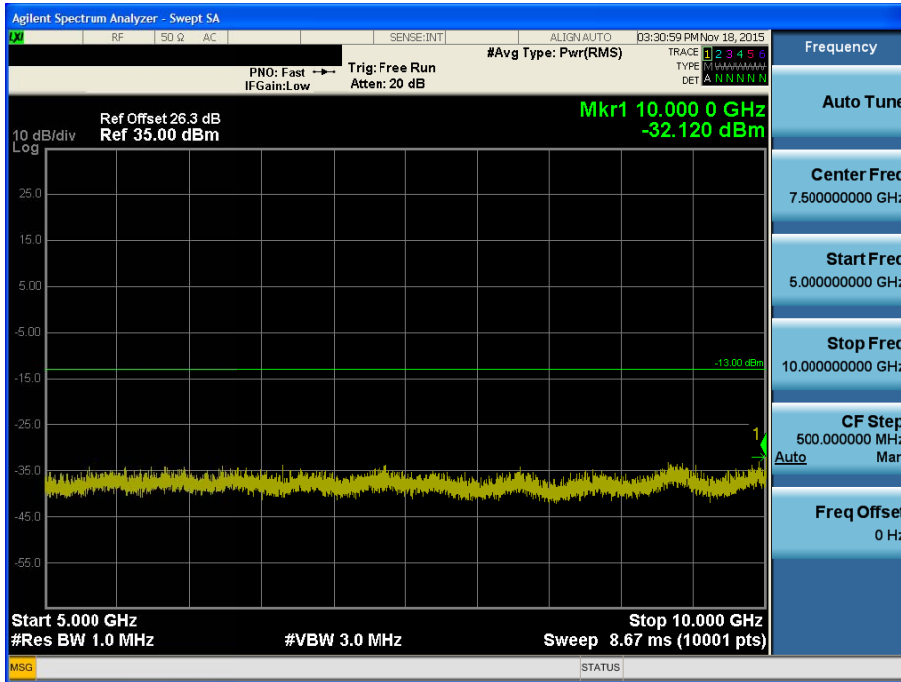

BAND 26. Conducted Spurious_1 (26740 ch_10MHz_QPSK_RB 1_0)

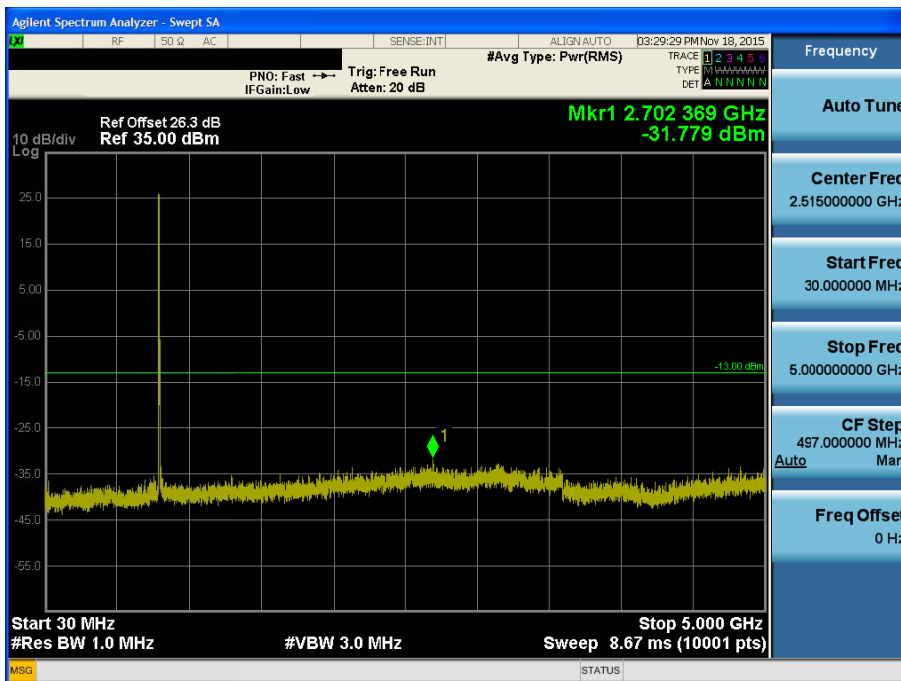

BAND 26. Conducted Spurious_2 (26740 ch_10MHz_QPSK_RB 1_0)

