

**CONFORMANCE TEST REPORT****FOR****Subpart E Part 24****Report No. : JNDL-NU-14R-0003**

**Client:** Franklin Technology Inc.  
**Product:** LTE/WIFI MOBILE ROUTER  
**Model:** R774  
**Manufacture/supplier:** Franklin Technology Inc.



**Date test item received:** 2014/04/18  
**Date test campaign completed:** 2014/05/29  
**Date of issue:** 2014/06/02

**ATTESTATION STATEMENT**

This equipment has been tested in accordance with the standards identified in the referenced test report. To the best of my knowledge and belief, these tests were performed using the measurement procedures described in this report and demonstrate that the equipment complies with the appropriate standards.

All JNDL Laboratory. CO., LTD instrumentation and accessories used to test products for compliance to the indicated standards are calibrated regularly in accordance with ISO 17025 requirements.

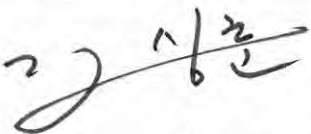
*Total number of pages of this test report : 46 pages*

Test engineer	Report reviewed by
 2014.6.2	 2014.6.2
Sang-hun kang	Kyoung-Pil, Yeom

## REPORT SUMMARY

Purpose of Test :	To demonstrate the EUT in compliance with Part 24 Subpart E of the FCC's
Disclaimer :	The test results relate only to the items tested.
Applicable Standards :	Part 24, Part 2, ANSI 63.4:2009, TIA-603-D-2010

## TEST ENVIRONMENT AND TEST SETUP

Test Facilities :	Test Firm Registration # : 748649 3m & 10m Open Site : 386-1, Ho-dong, Cheoin-gu, Yongin-si, Gyeonggi-do, Korea 3m semi-Anechoic chamber : B 114~115, 810 Kwanyang-Dong, dongan-Gu, Anyang-Si, Kyunggi-Do, 431-060, Korea
Laboratory Test Conditions :	Open Site : Temperature 25 °C, Humidity : 58 % 3m anechoic chamber : Temperature 26 °C, Humidity : 55 %
Test Exercise :	The EUT was set in continuous transmit mode of operation unless stated otherwise.
Modification to the EUT :	No modification was made.
Supporting Accessories :	None

## REVISION HISTORY

Revision	Date	Descriptions
0	2014.06.02	Original release

## Table of Contents

<i>1. General Remarks</i> .....	4
<i>2. Test Site</i> .....	4
2.1 Location .....	4
2.2 List of Test equipment used for tests.....	4
2.3 Test Date .....	4
<i>3. Description of the Equipment Under Test</i> .....	5
<i>4. List of Measurements</i> .....	6
<i>5. Description of Tests</i> .....	7
<i>6. Conducted Output power</i> .....	10
<i>7. Equivalent Isotropically Radiated power</i> .....	20
<i>8. Peak to Average Ratio</i> .....	23
<i>9. Modulation Characteristics</i> .....	25
<i>10. Occupied Bandwidth</i> .....	26
<i>11. Band Edge Compliance</i> .....	28
<i>12. Spurious Emission at Antenna Terminals</i> .....	32
<i>13. Field Strength of Spurious Radiation</i> .....	35
<i>14. Frequency Stability</i> .....	42

## 1. General Remarks

The test results in this report apply to the particular Equipment Under Test (EUT) as declared in this report.

The test results presented in this report relate only to the item tested.

## 2. Test Site

### 2.1 Location

#### JNDL Laboratory. CO., LTD. (Test Firm Registration # : 748649)

3m anechoic chamber : B 114~115, 810 Kwanyang-Dong, dongan-Gu, Anyang-Si, Kyunggi-Do, Korea

3m & 10m Open site : 386-1, Ho-dong, Cheoin-gu, Yongin-si, Gyeonggi-do, Korea

### 2.2 List of Test equipment used for tests

No.	Instrument	Model No.	Due to Calibration	Manufactor	Serial No.
<input checked="" type="checkbox"/>	PSA SPECTRUM ANALYZER (3 Hz ~ 26.5 GHz)	E4440A	2014-10-15	Agilent Technologies	MY46185375
<input checked="" type="checkbox"/>	SPECTRUM ANALYZER (20 Hz ~ 40.0 GHz)	FSP40	2015-01-08	Rohde & Schwarz	100308
<input checked="" type="checkbox"/>	SIGNAL GENERATOR (10 MHz ~ 40 GHz)	MG3694B	2014-10-15	Anritsu Corp	062513
<input checked="" type="checkbox"/>	POWER METER (DC ~ 67 GHz)	NRP2	2014-10-15	Rohde & Schwarz	100973
<input checked="" type="checkbox"/>	POWER SENSOR (50 MHz ~ 40 GHz)	NRP-Z85	2014-10-15	Rohde & Schwarz	101121
<input checked="" type="checkbox"/>	POWER SENSOR (9 KHz ~ 6 GHz)	NRP-Z92	2014-10-15	Rohde & Schwarz	100093
<input checked="" type="checkbox"/>	EMI TEST RECEIVER (20 MHz ~ 1000 MHz)	ESVS30	2014-10-15	Rohde & Schwarz	828525/005
<input type="checkbox"/>	COMMUNICATION TEST SET (WCDMA/CDMA/EVDO/PCS)	E5515C	2014-07-31	Agilent Technologies	MY50260242
<input checked="" type="checkbox"/>	COMMUNICATION TEST SET (LTE)	CMW500	2014-07-31	Rohde & Schwarz	140388
<input checked="" type="checkbox"/>	POWER DIVIDER (DC-18GHz)	1506A	2014-10-15	WEINSCHTEL	KW957
<input checked="" type="checkbox"/>	BILOG ANTENNA (30 MHz ~ 1000 MHz)	VULB 9168	2015-02-17	Schwarzbeck	9168-505
<input type="checkbox"/>	DIPOLE ANTENNA (30 MHz ~ 1 GHz)	UHAP	2016-04-01	Schwarzbeck	950
<input checked="" type="checkbox"/>	HORN ANTENNA (1 GHz ~ 18 GHz)	BBHA 9120D	2014-12-12	Schwarzbeck	568
<input checked="" type="checkbox"/>	HORN ANTENNA (1 GHz ~ 18 GHz)	3117	2014-10-24	ETS-Lindgren	00135889
<input checked="" type="checkbox"/>	Microwave Amplifier (1 GHz ~ 18 GHz)	TK-PA18	2014-09-05	TESTEK	1200020
<input checked="" type="checkbox"/>	Low Noise Amplifier (18 GHz ~ 40 GHz)	AMF-6F-18004000-37-8P	2015-05-06	MITEQ	1814914
<input checked="" type="checkbox"/>	High Power Amplifier (0.7 GHz ~ 2.5 GHz)	ZHL-30W-252-S+	N/A	Mini Circuit	804501219
<input type="checkbox"/>	High Pass Filter (1.5 GHz ~ 15 GHz)	WHKX1.5/15G-6SS	2015-03-17	WAINWRIGHT	4
<input checked="" type="checkbox"/>	High Pass Filter (3 GHz ~ 18 GHz)	WHK3.0/18G-10SS	2014-06-07	WAINWRIGHT	344

→ All equipment is calibrated with traceable calibrations.

### 2.3 Test Date

Date of Application: 2014- 04 - 18

Date of Test: 2014- 04 - 22 ~ 2014 - 05 - 29

### 3. Description of the Equipment Under Test

Manufacturer :	<b>Franklin Technology Inc.</b>
Product Description :	LTE/WIFI MOBILE ROUTER consists of LTE Band 12, LTE Band 25, Cellular CDMA, PCS CDMA, 1xRTT and EVDO Rev. 0 & Rev. A, WIFI(2.4 GHz)
FCC ID :	XHG-R774
Model Name :	R774
Multiple Model Name :	None
Operating Frequency :	TX : 1 852.50 MHz ~ 1 912.50 MHz RX : 1 932.50 MHz ~ 1 992.50 MHz
Modulation Type :	QPSK, 16QAM
Max. RF Output Power	• 0.890W EIRP LTE Band 25(29.49 dBm)
Emission Designator	• 4M52G7D LTE Band 25 (Channel Bandwidth : 5 MHz)
EUT Power Source :	Primary power – 3.7 Vdc Battery
	Secondary Power – Via AC Mains Powered DC 5V adapter
Test Item :	Prototype
Type of Equipment :	Mobile
Antennas :	PIFA Internal Antenna Max peak gain : -1.7 dBi
Antenna Connector :	DIP Connection(INTENNA)

- ➔ All the testing were performed according to the procedures in FCC Parts 24 & Parts 2  
The EUT was operation with Communication Simulator (CMW500)
- ➔ EUT not support the additional bandwidth 1.4 MHz, 3 MHz, 10 MHz system.
- ➔ EUT only support 5 MHz bandwidth system.

#### 4. List of Measurements

Guide Lines	FCC Rules Part	Test Conditon	Result
Conducted Output Power	2.1046	Conducted	PASS
Equivalent Isotropically Radiated Power	24.232	Radiated	PASS
Peak to Average Ratio	24.232(d)	Conducted	PASS
Modulation Characteristics	2.1047	Conducted	PASS
Occupied Bandwidth	24.238(a) / 2.1049	Conducted	PASS
Band Edges Compliance	24.238(b) / 2.1051	Conducted	PASS
Spurious Emission at Antenna Terminals	24.238(a) / 2.1051	Conducted	PASS
Field Strength of Spurious Radiation	24.238(a) / 2.1053	Radiated	PASS
Frequency Stability	24.235 / 2.1055	Conducted	PASS

## 5. Description of Tests

### 5.1 Conducted power / Modulation Characteristics

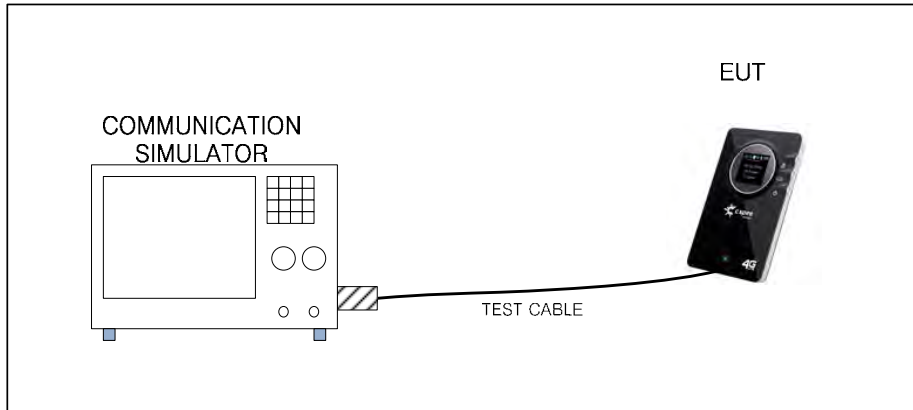

### 5.2 Peak to Average Ratio / Occupied Bandwidth / Band Edges Compliance / Spurious Emission at Antenna Terminals

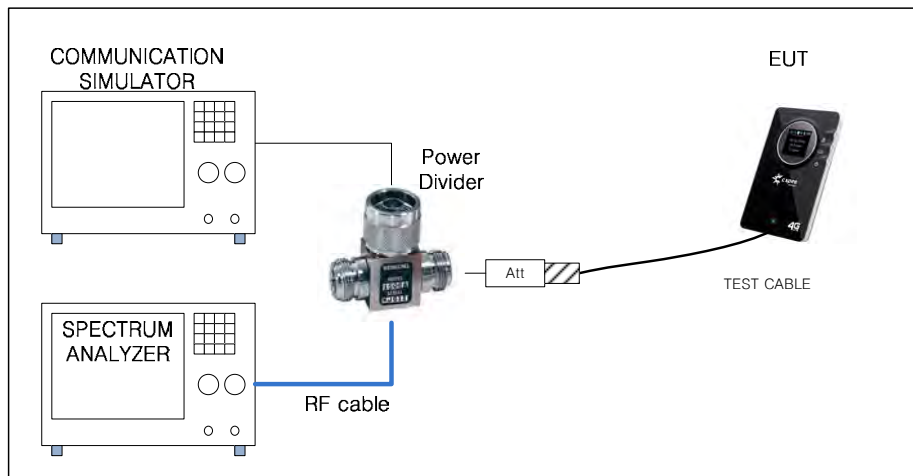

### 5.3 Equivalent Isotropically Radiated Power / Field Strength of Spurious radiation

#### 5.3.1 Test setup for 30 MHz ~ 1 GHz

The diagram below shows the test setup that is utilized to make the measurements for emission from 30 MHz to 1 GHz emissions

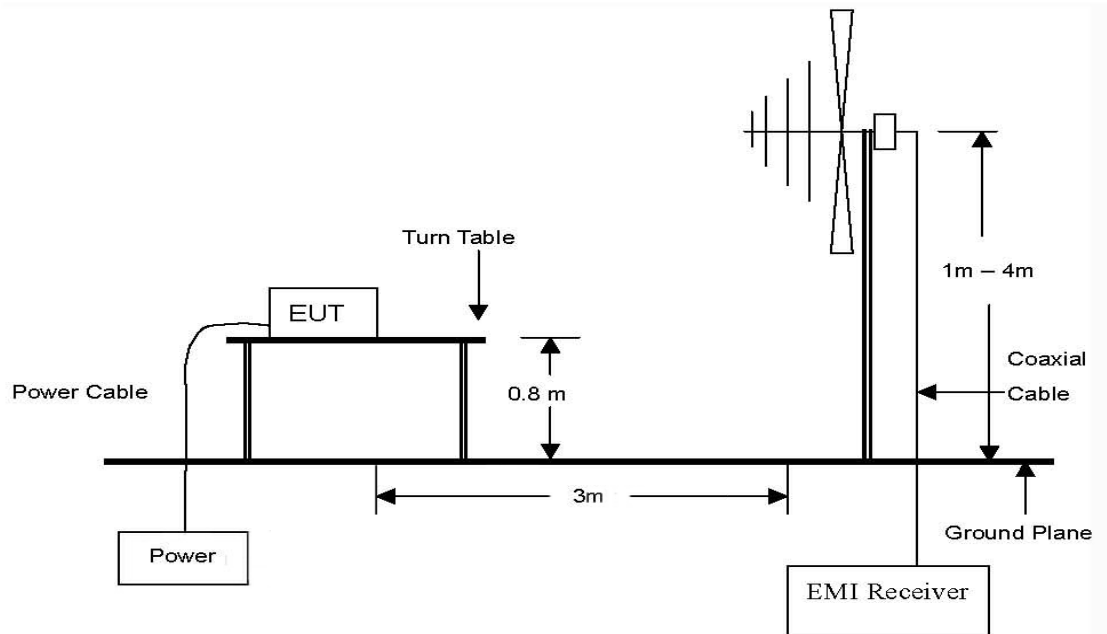

#### 5.3.2 Test setup for 1 GHz ~ 20 GHz

The diagram below shows the test setup that is utilized to make the measurements for emission from 1 GHz to 20 GHz emissions. As required by subpart 15.33 emissions were measured to 20 GHz.(10th carrier frequency)

\* EIRP measurement not use filter, it only use Field Strength of Spurious emissions.

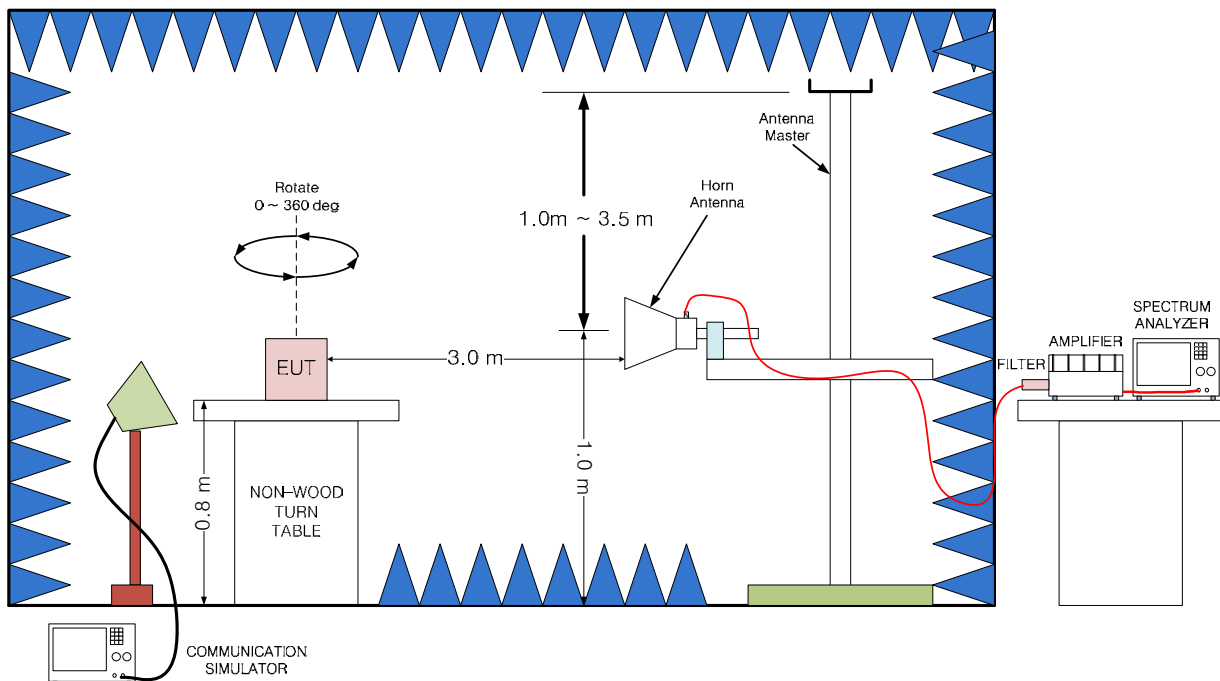



### 5.4 Frequency Stability

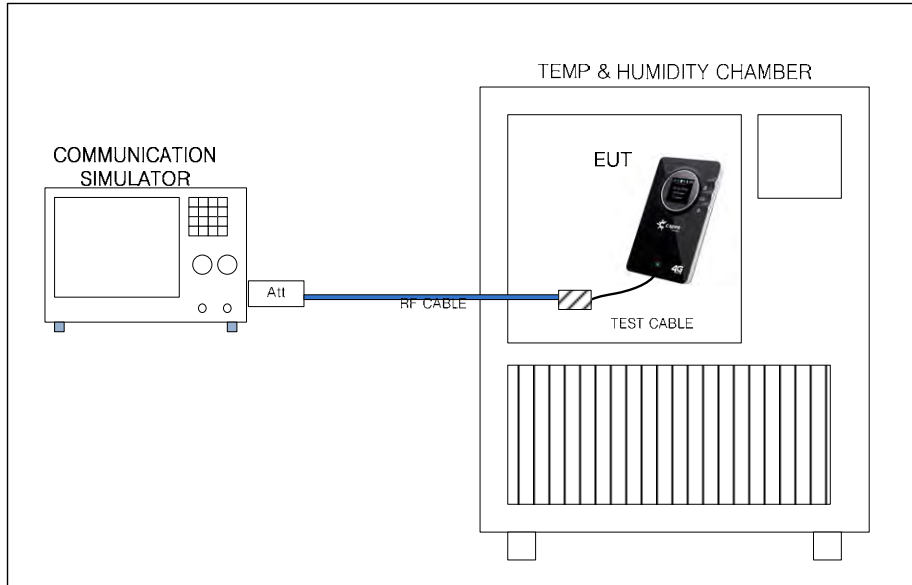

### 5.5 Worst-case Configuration and mode

Radiated emission and conducted emission were performed with the EUT set to transmit at the channel with highest output power as worst-case scenario.

The fundamental of the EUT was investigated in three orthogonal orientations XY, YZ, ZX, it was determined that XY orientation was worst-case orientation

Based on the baseline scan, the worst-case were:

QPSK Modulation : RB 1#0 (Resource Block Size / Resource Block Offset)

16QAM Modulation : RB 1#0 (Resource Block Size / Resource Block Offset)

### 5.6 EUT operating conditions

The Eut makes a call to the communication simulator. The communication simulator station system controlled a EUT to export maximum output power under transmittion mode and specific channel frequency.

### 5.7 Methods and Procedure

Reference :	47 FCC PART 24 subpart E
Title :	BROADBAND PCS
Reference :	47 FCC PART 2
Title :	FREQUENCY ALLOCATIONS AND RADIO TREATY MATTERS; GENERAL RULES AND REGULATIONS
Reference :	ANSI / TIA-603-D-2010
Title :	Land mobile fm or pm communications equipment measurement and performance standards
Reference :	FCC KDB 971168 D01 v02r01, 7 June 2013
Title:	Measurement Guidance for Certification of Licensed Digital Transmitters

## 6. Conducted Output power

### 6.1 Test Procedure

A base station simulator was used to establish communication with The EUT. The base station simulator parameters were set to produce the maximum power from the EUT. This device was tested under all configurations and the highest power is reported. Conducted Output Powers of EUT are reported below.

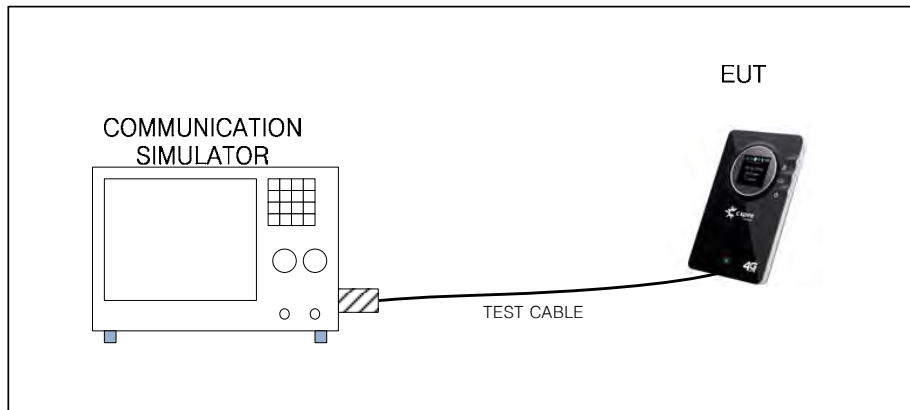

\* Simulator call mode : all bit up (MAX Power mode)

\* TEST Cable : Connect PCS Antenna PORT (0.6dB loss / 30 cm / MCX to SMA Cable)

### 6.2 Test Result

Unit : dBm

Modulation	Resource Block Size	Resource Block Offset	Low ch : 26065	Mid ch : 26365	High ch : 26665
			Freq(MHz) : 1 852.50	Freq(MHz) : 1 882.50	Freq(MHz) : 1 912.50
QPSK	1	0	23.43	23.31	23.29
	1	13	23.46	23.22	23.42
	1	24	23.30	23.27	23.00
	12	0	22.39	22.28	22.30
	12	6	22.46	22.24	22.38
	12	13	22.48	22.21	22.26
	25	0	22.27	22.18	22.07
16QAM	1	0	21.97	22.45	22.75
	1	13	21.99	22.40	22.71
	1	24	22.02	22.43	22.40
	12	0	21.34	21.38	21.40
	12	6	21.38	21.37	21.35
	12	13	21.45	21.34	21.28
	25	0	21.45	21.27	21.17

\* Average power

### 6.3 Test Plots

\* CH:26065(1 852.50 MHz)

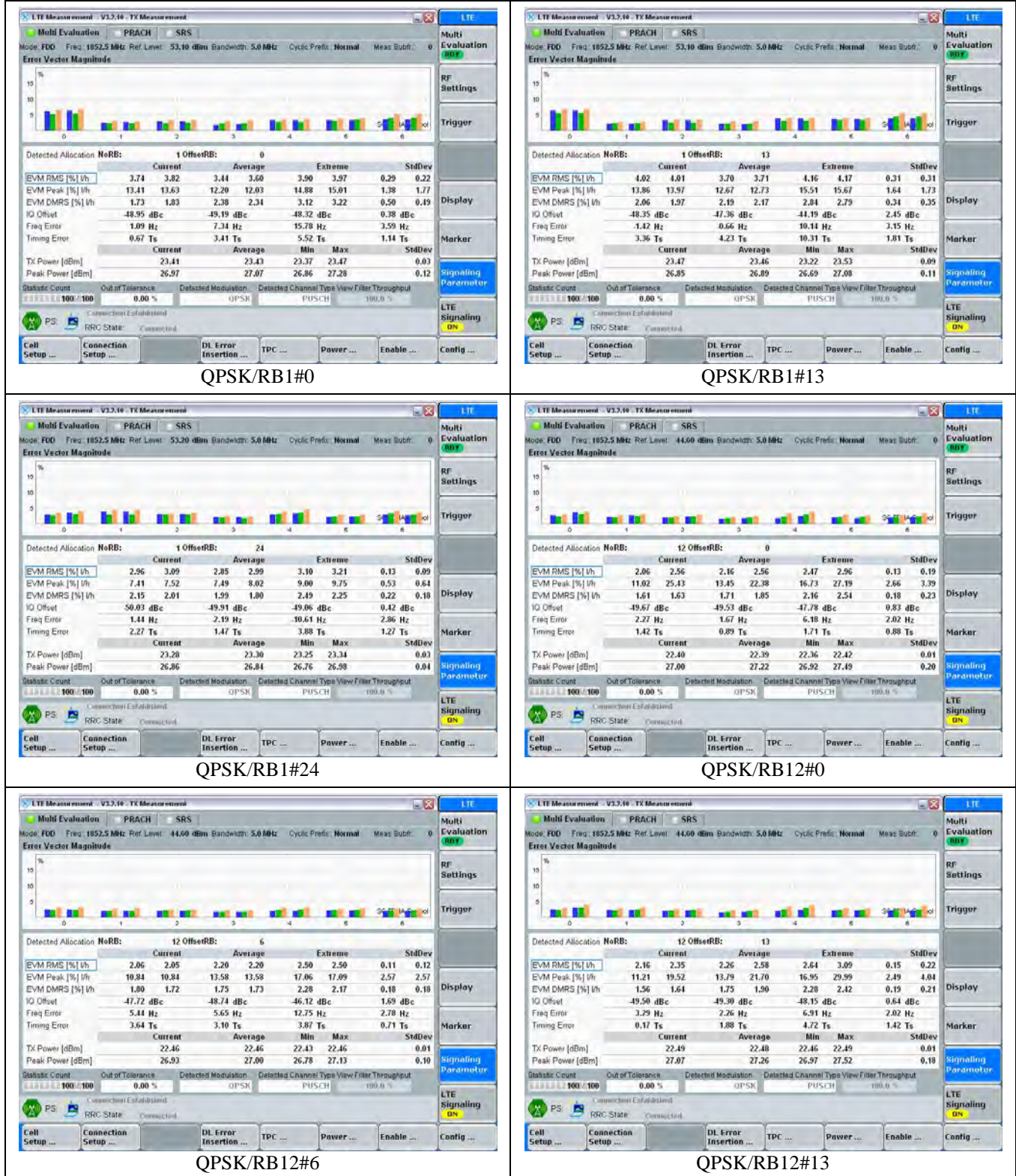



\* CH:26065(1 852.50 MHz)

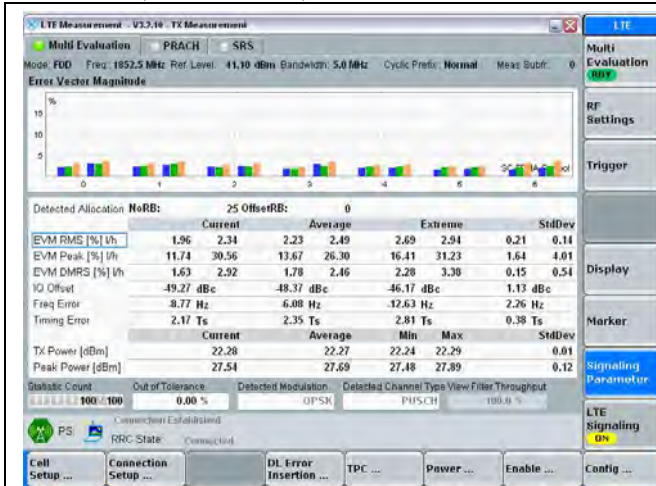

QPSK/RB25#0

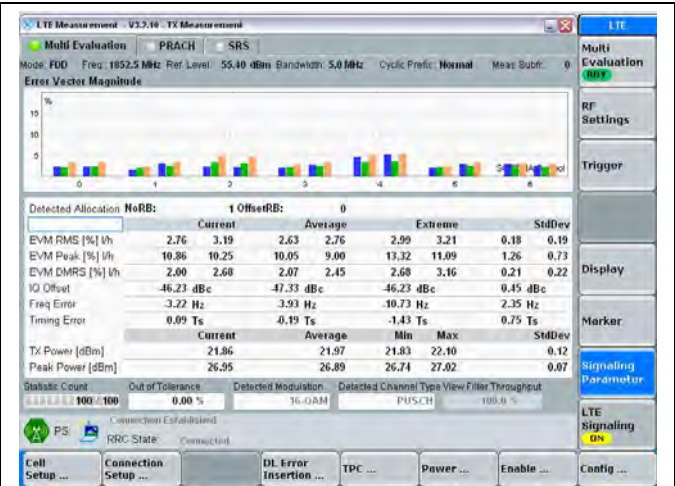

16QAM/RB1#0

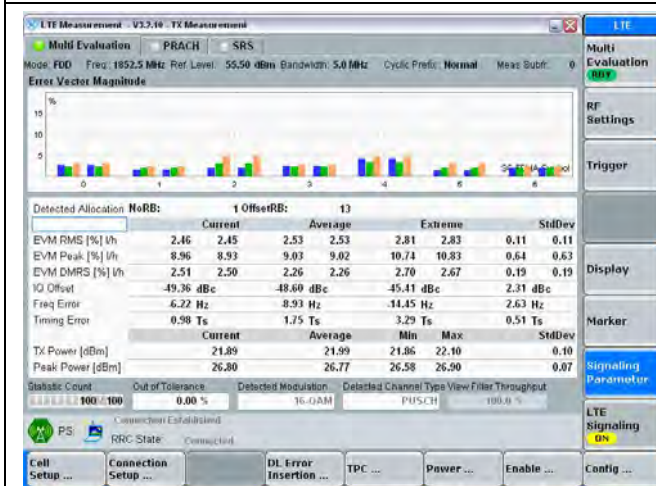

16QAM/RB1#13

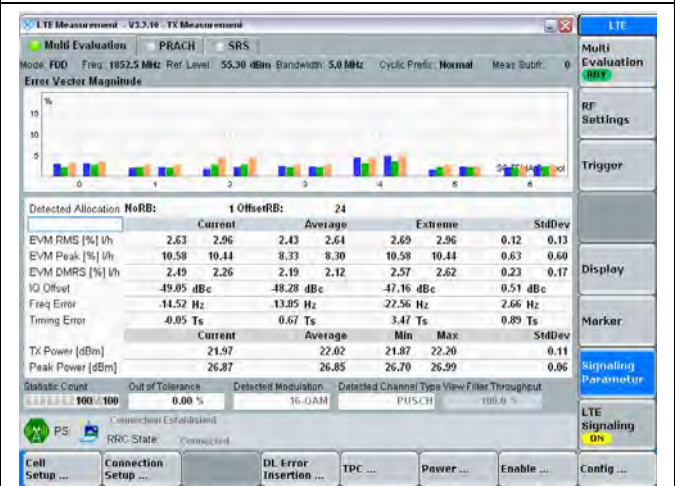

16QAM/RB1#24



16QAM/RB12#0

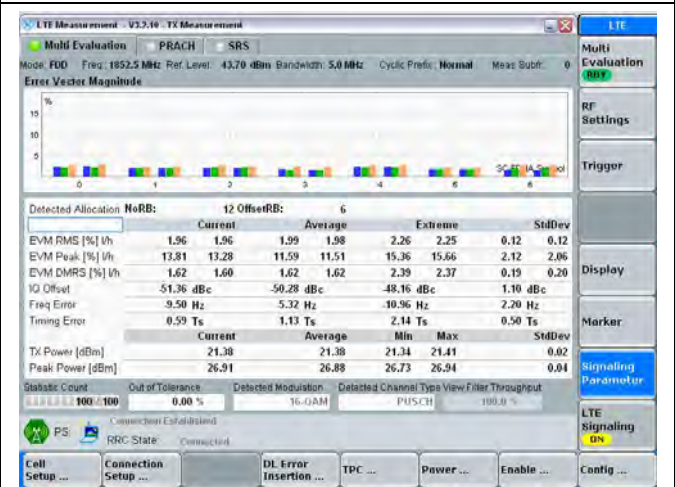

16QAM/RB12#6

\* CH:26065(1 852.50 MHz)

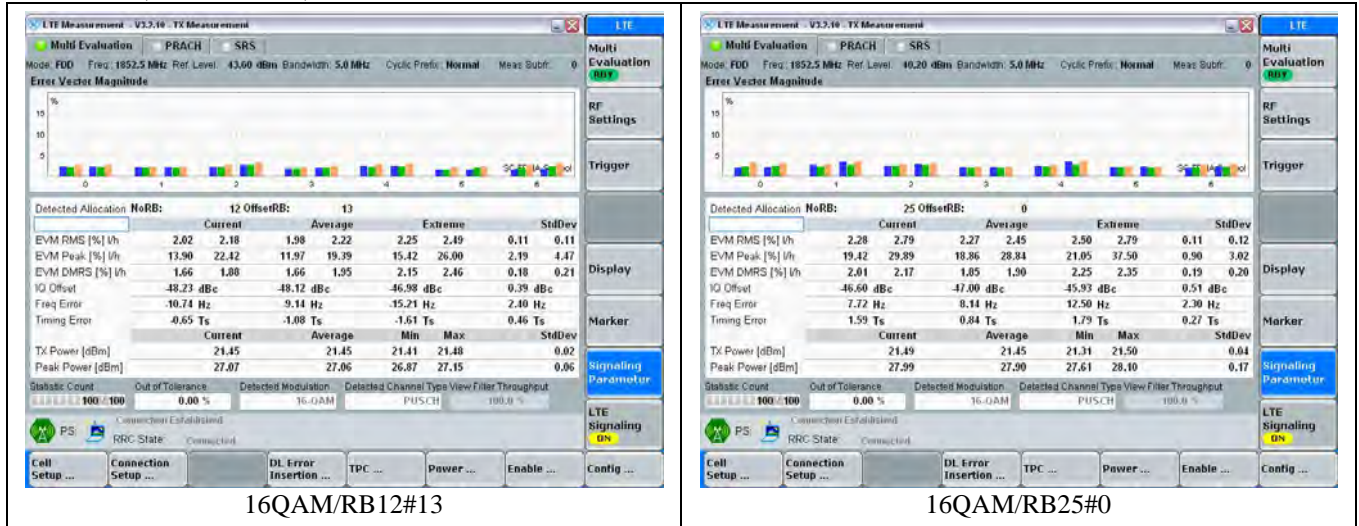



\* CH:26365(1 882.50 MHz)

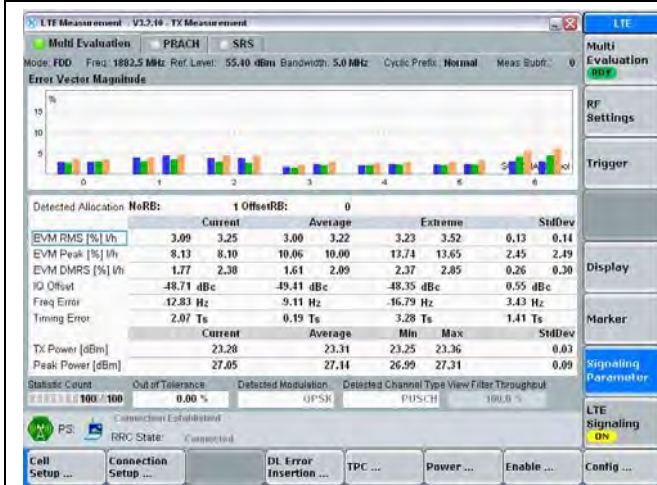

QPSK/RB1#0

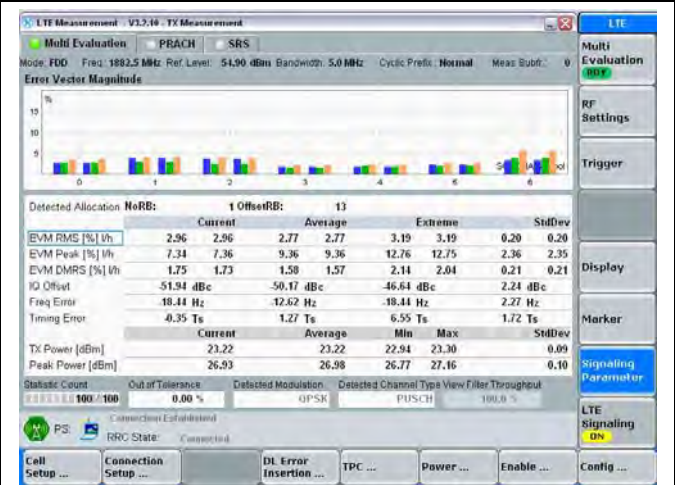

QPSK/RB1#13

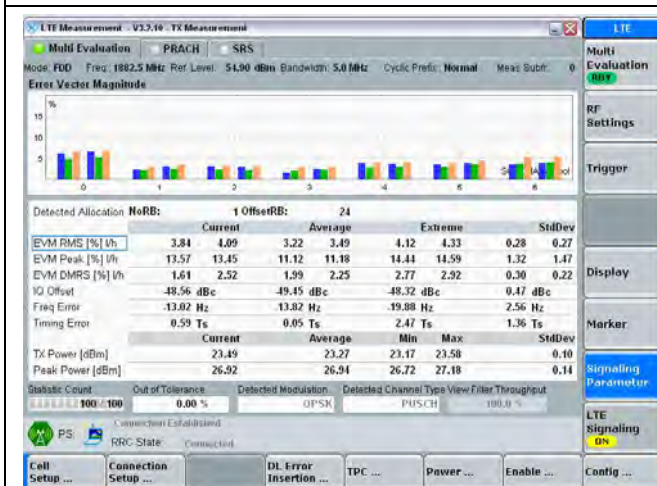

QPSK/RB1#24

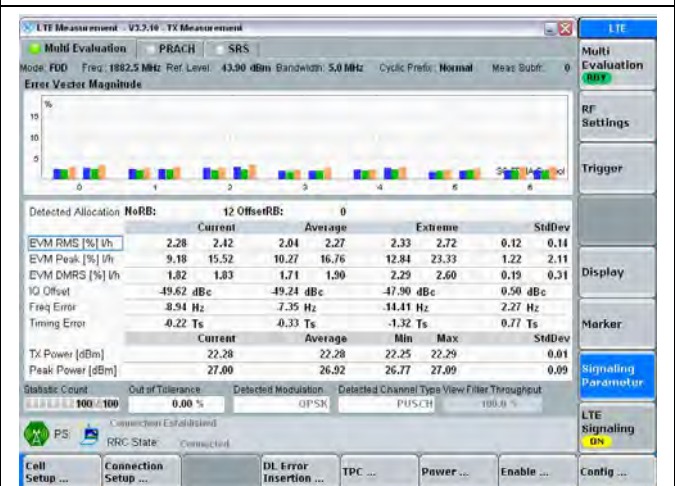

QPSK/RB12#0



QPSK/RB12#6

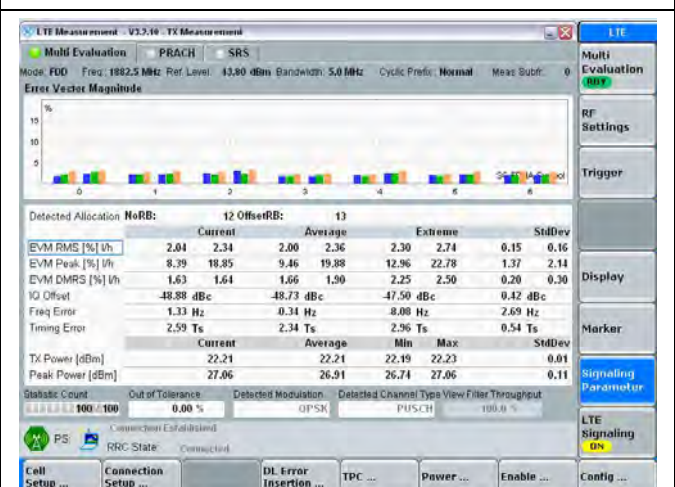

QPSK/RB12#13



\* CH:26365(1 882.50 MHz)

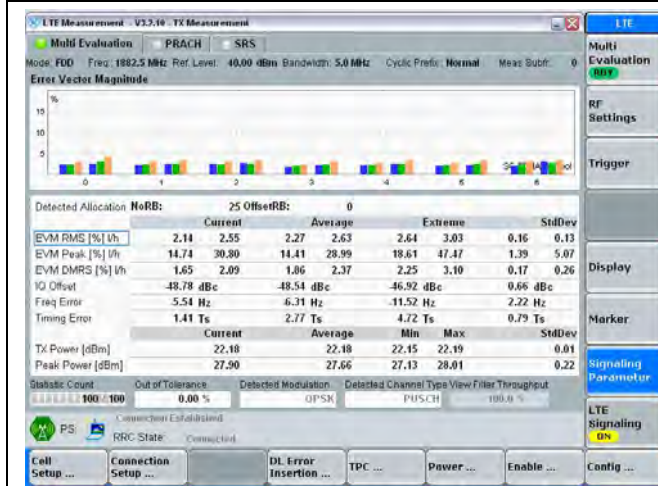

QPSK/RB25#0

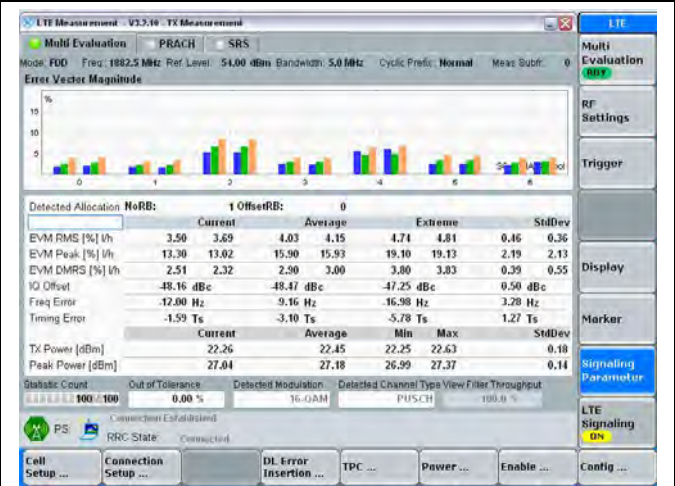

16QAM/RB1#0

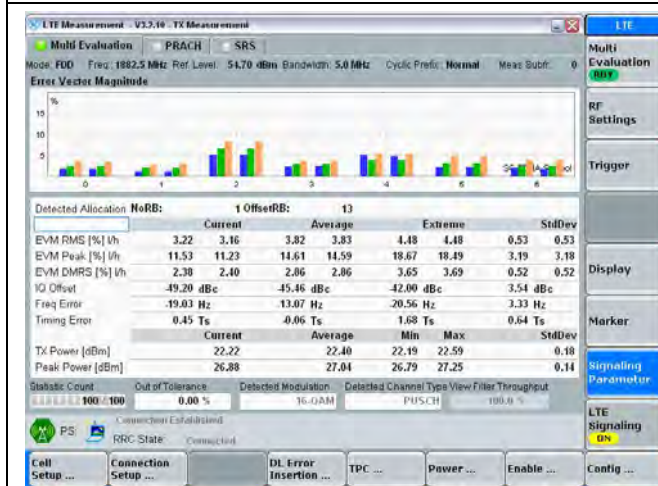

16QAM/RB1#13

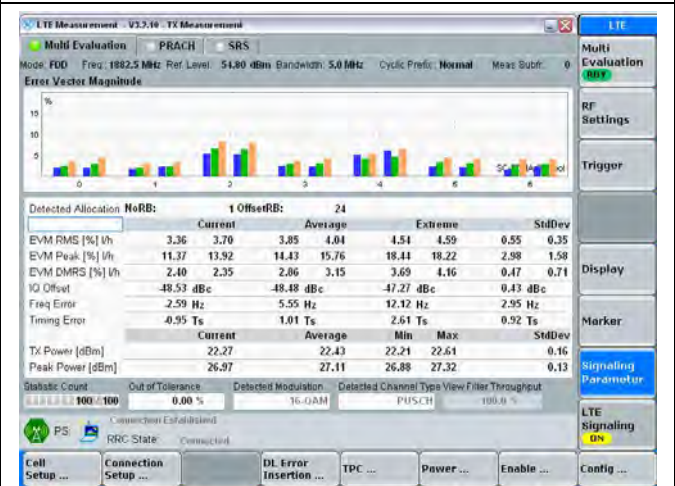

16QAM/RB1#24



16QAM/RB12#0

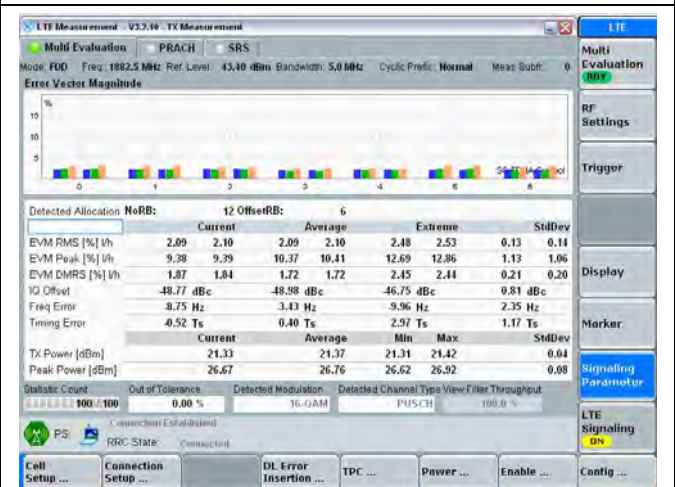

16QAM/RB12#6

\* CH:26365(1 882.50 MHz)

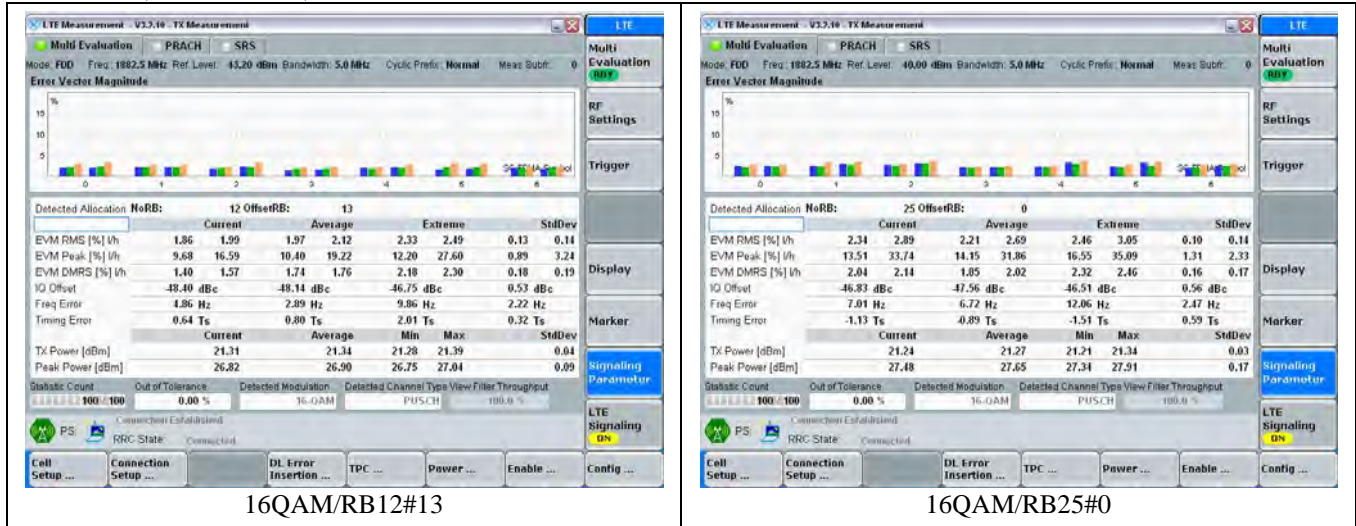



\* CH:26665(1 912.50 MHz)



QPSK/RB1#0

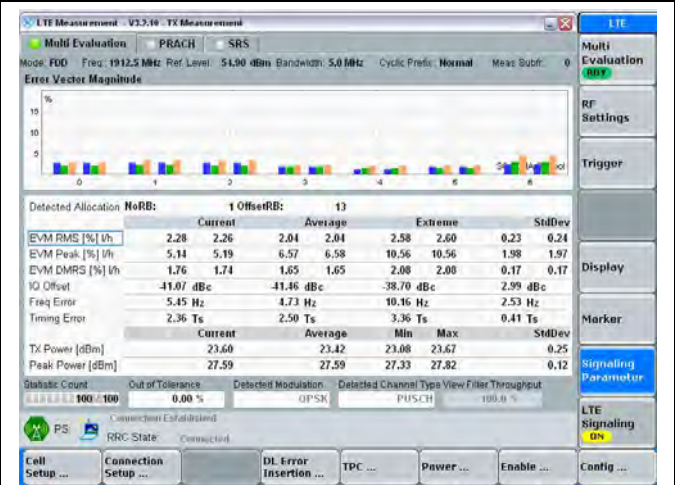

QPSK/RB1#13

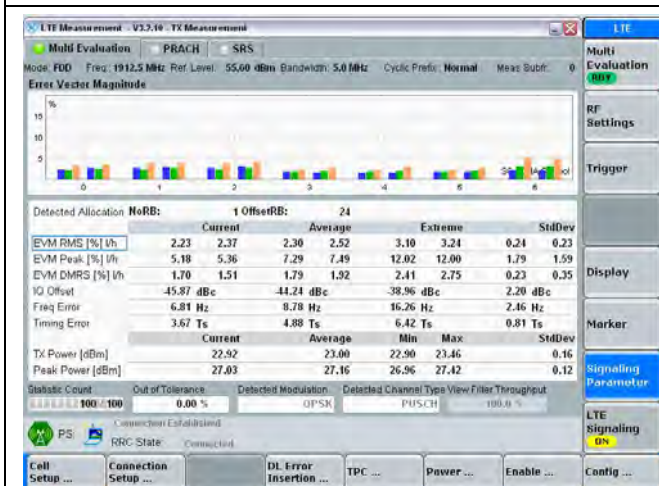

QPSK/RB1#24

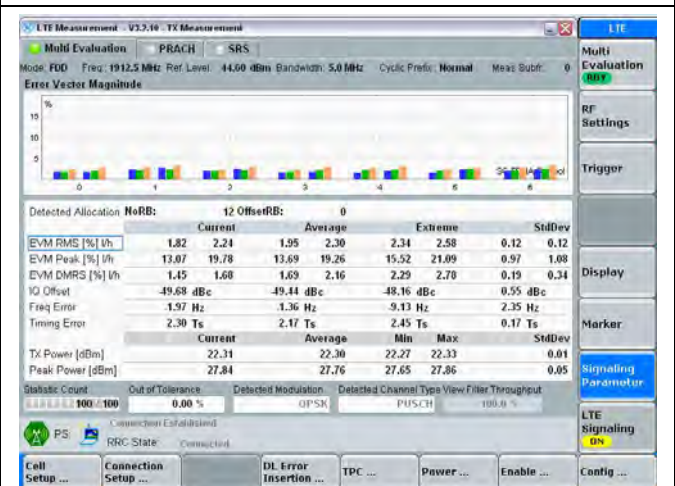

QPSK/RB12#0

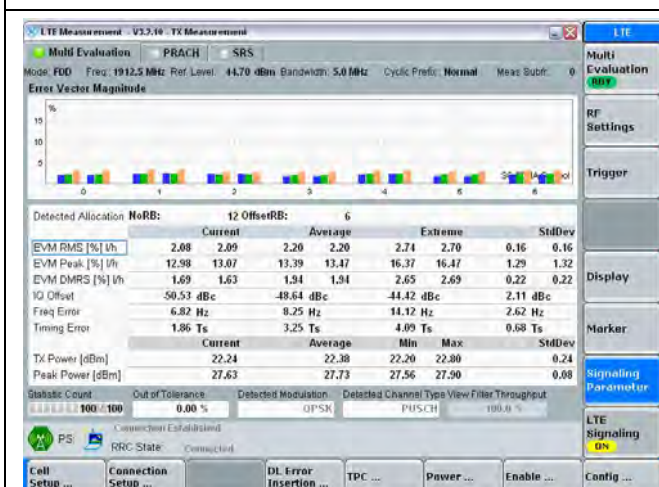

QPSK/RB12#6

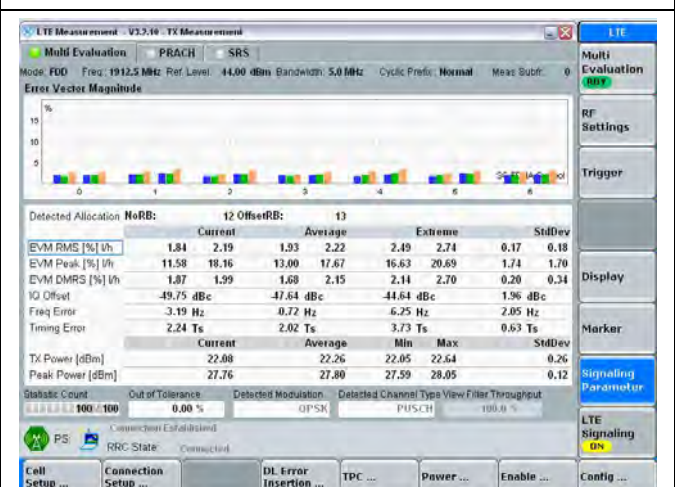

QPSK/RB12#13



\* CH:26665(1 912.50 MHz)

<p>QPSK/RB25#0</p>	<p>16QAM/RB1#0</p>
<p>16QAM/RB1#13</p>	<p>16QAM/RB1#24</p>
<p>16QAM/RB12#0</p>	<p>16QAM/RB12#6</p>

\* CH:26665(1 912.50 MHz)

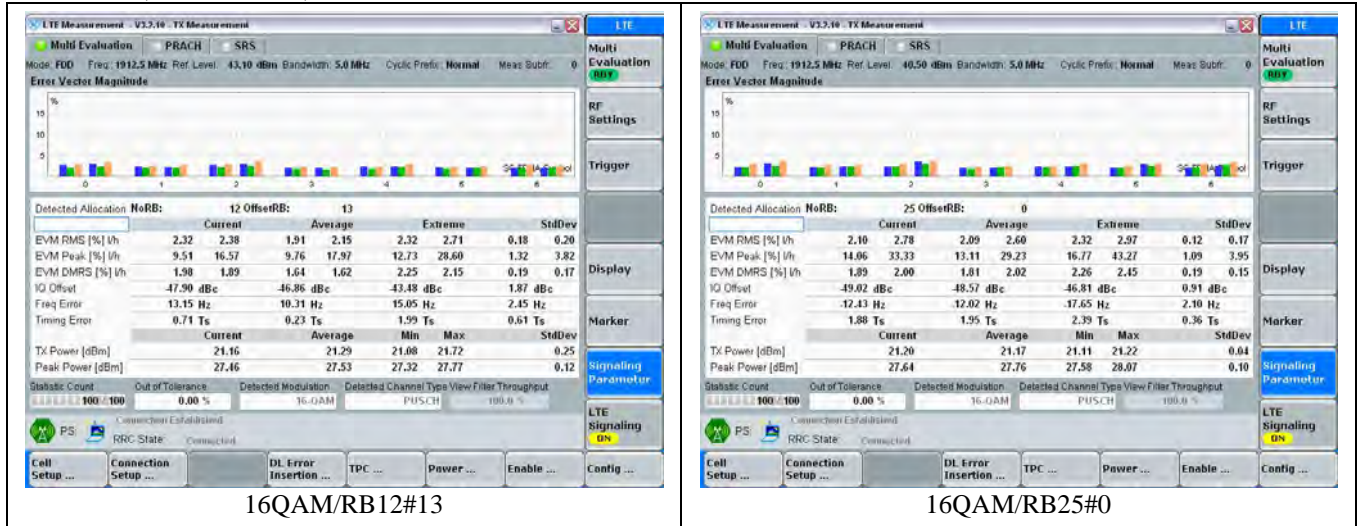

## 7. Equivalent Isotropically Radiated power

### 7.1 Test Procedure

- a. All measurements were done at low, middle and high operational frequency range. RBW and VBW is 10MHz for LTE Band 25.
- b. Substitution method is used for EIRP measurement. In the open-site chamber, EUT placed on the 0.8m height of Turn Table, rotated the table around 360 degrees to search the maximum radiation power and receiver antenna shall be rotated vertical and horizontal polarization and moved height from 1m to 4m to find the maximum polar radiated power. The “Read Value” is the spectrum reading the maximum power value.
- c. The substitution Horn antenna is substituted for EUT at the same position and signals generator export the CW signal to the substitution antenna via a tx cable. Rotated the Turn Table and moved receiving antenna to find the maximum radiation power. Adjust output power level of S.G to get a Value of spectrum reading equal to “Read Value” of step b. Record the power level of S.G
- d.  $EIRP = \text{Output power level of S.G} - \text{TX cable loss} + \text{Antenna gain of substitution Horn}$

\* This device was tested under all configurations and the highest power is reported. Also, we have done XY, YZ, ZX planes in EUT and horizontal and vertical polarization in detecting antenna.

\* The worst case of LTE Band 25 is

QPSK Modulation : RB1#0

16QAM Modulation : RB1#0

\* Configuration : refer to 5.3 chapter.

\* Simulator call mode : all bit up(Max Power)

### 7.2 Test Result

Modulation	Resource Block Size	Resource Block Offset	Low ch :	Mid ch :	High ch :
			26065	26365	26665
			Freq(MHz) :	Freq(MHz) :	Freq(MHz) :
			1 852.50	1 882.50	1 912.50
QPSK	1	0	0.500 W (26.99 dBm)	0.797 W (29.01 dBm)	0.890 W (29.49 dBm)
16QAM	1	0	0.442 W (26.45 dBm)	0.712 W (28.52 dBm)	0.742 W (28.70 dBm)

### 7.3 Test Criteria

The EIRP of mobile transmitters and auxiliary test transmitters must not exceed 2 Watts.



### 7.3 Test Result

#### 7.3.1 XY SCAN

MODE	CH /FREQ		Polar	SCAN	Measured Level	Measured Level	Substitute Level	ANT Gain	Cable Loss	EIRP	
	CHANNEL	FREQ (MHz)	Hor/Ver	X,Y,Z	(dBuV)	(dBm)	(dBm)	(dB)	(dB)	W	dBm
QPSK / RB 1#0	26065	1852.50	V	XY	83.77	-23.23	16.36	5.76	2.87	0.084	19.26
	26365	1882.50		XY	86.83	-20.17	19.34	5.76	2.97	0.163	22.13
	26665	1912.50		XY	87.41	-19.59	20.99	5.75	2.96	0.239	23.78
QPSK / RB 1#0	26065	1852.50	H	XY	82.22	-24.78	14.94	5.76	2.87	0.061	17.84
	26365	1882.50		XY	82.71	-24.29	15.62	5.76	2.97	0.069	18.41
	26665	1912.50		XY	86.22	-20.78	18.61	5.75	2.96	0.138	21.40
16-QAM / RB 1#0	26065	1852.50	V	XY	84.35	-22.65	16.94	5.76	2.87	0.096	19.84
	26365	1882.50		XY	86.80	-20.20	19.31	5.76	2.97	0.162	22.10
	26665	1912.50		XY	87.10	-19.90	20.68	5.75	2.96	0.222	23.47
16-QAM / RB 1#0	26065	1852.50	H	XY	80.94	-26.06	13.66	5.76	2.87	0.045	16.56
	26365	1882.50		XY	83.07	-23.93	15.98	5.76	2.97	0.075	18.77
	26665	1912.50		XY	87.07	-19.93	19.46	5.75	2.96	0.168	22.25

#### 7.3.2 YZ SCAN

MODE	CH /FREQ		Polar	SCAN	Measured Level	Measured Level	Substitute Level	ANT Gain	Cable Loss	EIRP	
	CHANNEL	FREQ (MHz)	Hor/Ver	X,Y,Z	(dBuV)	(dBm)	(dBm)	(dB)	(dB)	W	dBm
QPSK / RB 1#0	26065	1852.50	V	YZ	80.14	-26.86	12.73	5.76	2.87	0.037	15.63
	26365	1882.50		YZ	82.62	-24.38	15.13	5.76	2.97	0.062	17.92
	26665	1912.50		YZ	86.17	-20.83	19.75	5.75	2.96	0.180	22.54
QPSK / RB 1#0	26065	1852.50	H	YZ	91.37	-15.63	24.09	5.76	2.87	0.500	26.99
	26365	1882.50		YZ	93.31	-13.69	26.22	5.76	2.97	0.797	29.01
	26665	1912.50		YZ	94.31	-12.69	26.70	5.75	2.96	0.890	29.49
16-QAM / RB 1#0	26065	1852.50	V	YZ	80.89	-26.11	13.48	5.76	2.87	0.043	16.38
	26365	1882.50		YZ	83.39	-23.61	15.90	5.76	2.97	0.074	18.69
	26665	1912.50		YZ	85.68	-21.32	19.26	5.75	2.96	0.160	22.05
16-QAM / RB 1#0	26065	1852.50	H	YZ	90.83	-16.17	23.55	5.76	2.87	0.442	26.45
	26365	1882.50		YZ	92.82	-14.18	25.73	5.76	2.97	0.712	28.52
	26665	1912.50		YZ	93.52	-13.48	25.91	5.75	2.96	0.742	28.70

## 7.3.3 ZX SCAN

MODE	CH /FREQ		Polar	SCAN	Measured Level	Measured Level	Substitute Level	ANT Gain	Cable Loss	EIRP	
	CHANNEL	FREQ (MHz)	Hor/Ver	X,Y,Z	(dBuV)	(dBm)	(dBm)	(dB)	(dB)	W	dBm
QPSK / RB 1#0	26065	1852.50	V	ZX	86.29	-20.71	18.88	5.76	2.87	0.151	21.78
	26365	1882.50		ZX	86.04	-20.96	18.55	5.76	2.97	0.136	21.34
	26665	1912.50		ZX	89.13	-17.87	22.71	5.75	2.96	0.355	25.50
QPSK / RB 1#0	26065	1852.50	H	ZX	86.32	-20.68	19.04	5.76	2.87	0.156	21.94
	26365	1882.50		ZX	88.88	-18.12	21.79	5.76	2.97	0.287	24.58
	26665	1912.50		ZX	91.63	-15.37	24.02	5.75	2.96	0.480	26.81
16-QAM / RB 1#0	26065	1852.50	V	ZX	85.89	-21.11	18.48	5.76	2.87	0.137	21.38
	26365	1882.50		ZX	86.04	-20.96	18.55	5.76	2.97	0.136	21.34
	26665	1912.50		ZX	88.97	-18.03	22.55	5.75	2.96	0.342	25.34
16-QAM / RB 1#0	26065	1852.50	H	ZX	85.77	-21.23	18.49	5.76	2.87	0.138	21.39
	26365	1882.50		ZX	88.79	-18.21	21.70	5.76	2.97	0.281	24.49
	26665	1912.50		ZX	90.87	-16.13	23.26	5.75	2.96	0.403	26.05

## 8. Peak to Average Ratio

### 8.1 Test Procedure

A peak to average ratio measurement is performed at the conducted port of the EUT. For CDMA and WCDMA signals, the spectrum analyzers Complementary Cumulative Distribution Function (CCDF) measurement profile is used to determine the largest deviation between the average and the peak power of the EUT in a given bandwidth. The CCDF curve shows how much time the peak waveform spends at or above a given average power level. The percent of time the signal spends at or above the level defines the probability for that particular power level.

- a. Set resolution/measurement bandwidth  $\geq$  signal's occupied bandwidth
- b. Set the number of counts to a value that stabilizes the measured CCDF curve

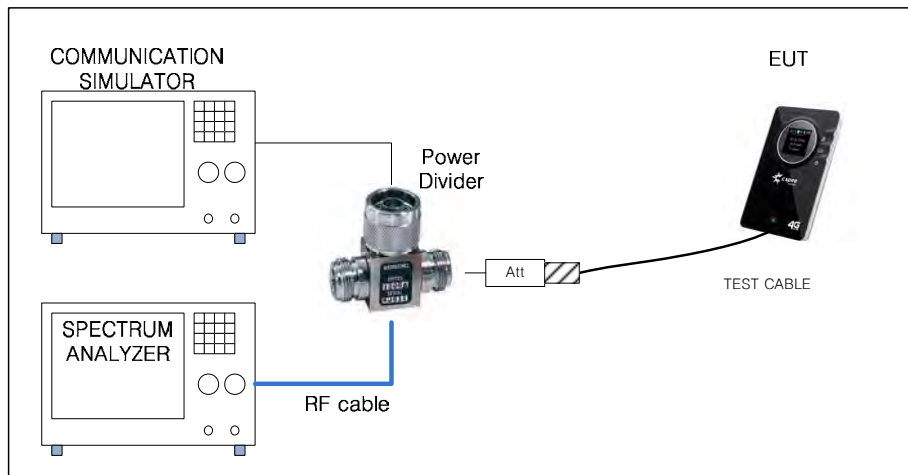

- \* Simulator call mode : all bit up
- \* TEST Cable : Connect LTE Antenna PORT (0.6dB loss / 30 cm / MCX to SMA Cable)
- \* RF Cable : HUBER+SHUNER / SUCOFLEX 104 / DC-18 GHz / 1.0 m
- \* Attenuator : 10 dB (Weinshel /56-10/ DC-28 GHz) + 10 dB(Weinshel / 56-10 / DC-28 GHz)
- \* Power Divider : WEINSCHEL / 1506A / DC-18 GHz / 3 Port
- \* Path Loss Information

Frequency (MHz)	RF Cable (dB)	10 dB ATT (dB)	10 dB ATT (dB)	Power Diver (dB)	Test Cable (dB)	Total Loss (dB)
1 882.50	0.45	9.62	9.61	5.78	0.60	26.06

### 8.2 Test Result

Unit : dB

Modulation	Resource Block Size	Resource Block Offset	Low ch : 26065	Mid ch : 26365	High ch : 26665
			Freq(MHz) : 1 852.50	Freq(MHz) : 1 882.50	Freq(MHz) : 1 912.50
QPSK	1	0	3.78	3.96	4.03
16QAM	1	0	4.79	5.12	5.02

### 8.3 Test Criteria

In measuring transmissions in this band using an average power technique, the peak to average ratio of the transmission may not exceed 13 dB (associated with a probability of 0.1%)

### 8.4 Test Plots





## 9. Modulation Characteristics

### 9.1 Definition

Other types of equipment. A curve or equivalent data which shows that the equipment will meet the modulation requirements of the rules under which the equipment is to be licensed.

### 9.2 Test Procedure

The measurement frequency is center channel(26365)

It measured RB 25#0 both QPSK and 16QAM Modulation(worst case)

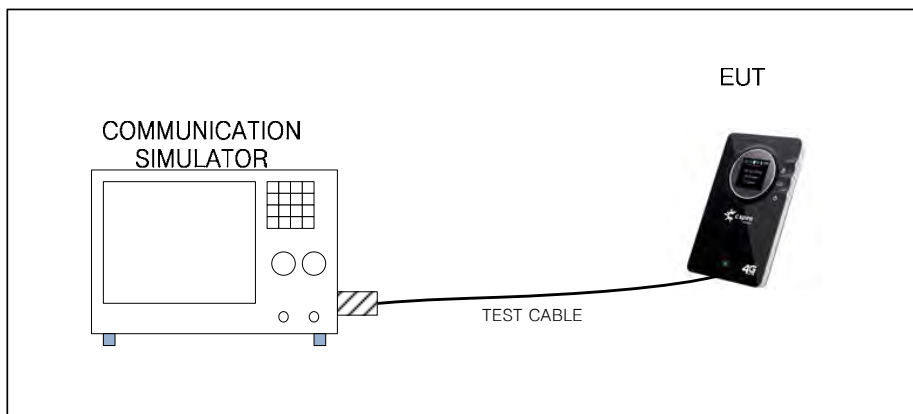

### 9.4 Test Plots

\* CH:26365 (1 882.50 MHz)

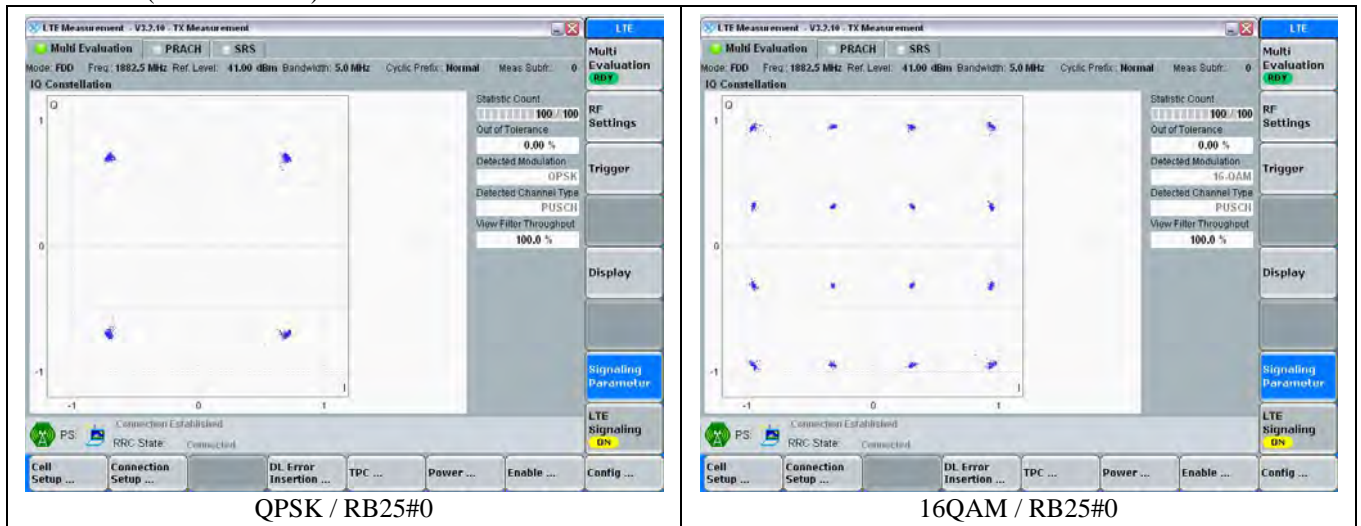

## 10. Occupied Bandwidth

### 10.1 Definition

The occupied bandwidth, that is the frequency bandwidth such that, below its lower and above its upper frequency limits, the mean powers radiated are each equal to 0.5 percent of the total mean power radiated by a given emission shall be measured under the following conditions as applicable:

### 10.2 Test Procedure

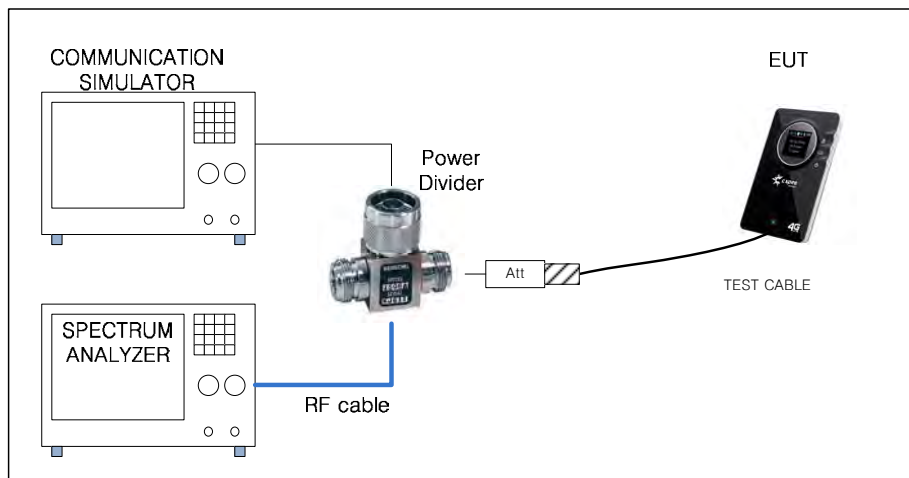

\* Simulator call mode : all bit up

\* TEST Cable : Connect LTE Antenna PORT (0.6dB loss / 30 cm / MCX to SMA Cable)

\* RF Cable : HUBER+SHUNER / SUCOFLEX 104 / DC-18 GHz / 1.0 m

\* Attenuator : 10 dB (Weinshel / 56-10/ DC-28 GHz) + 10 dB(Weinshel / 56-10 / DC-28 GHz)

\* Power Divider : WEINSCHEL / 1506A / DC-18 GHz / 3 Port

\* Path Loss Information

Frequency (MHz)	RF Cable (dB)	10 dB ATT (dB)	10 dB ATT (dB)	Power Diver (dB)	Test Cable (dB)	Total Loss (dB)
1 882.50	0.45	9.62	9.61	5.78	0.60	26.06

### 10.3 Test Result

Unit : MHz

Modulation	Resource Block Size	Resource Block Offset	Low ch : 26065	Mid ch : 26365	High ch : 26665
			Freq(MHz) : 1 852.50	Freq(MHz) : 1 882.50	Freq(MHz) : 1 912.50
QPSK	25	0	4.493	4.482	4.503
16QAM	25	0	4.510	4.499	4.522

### 10.4 Test Plots

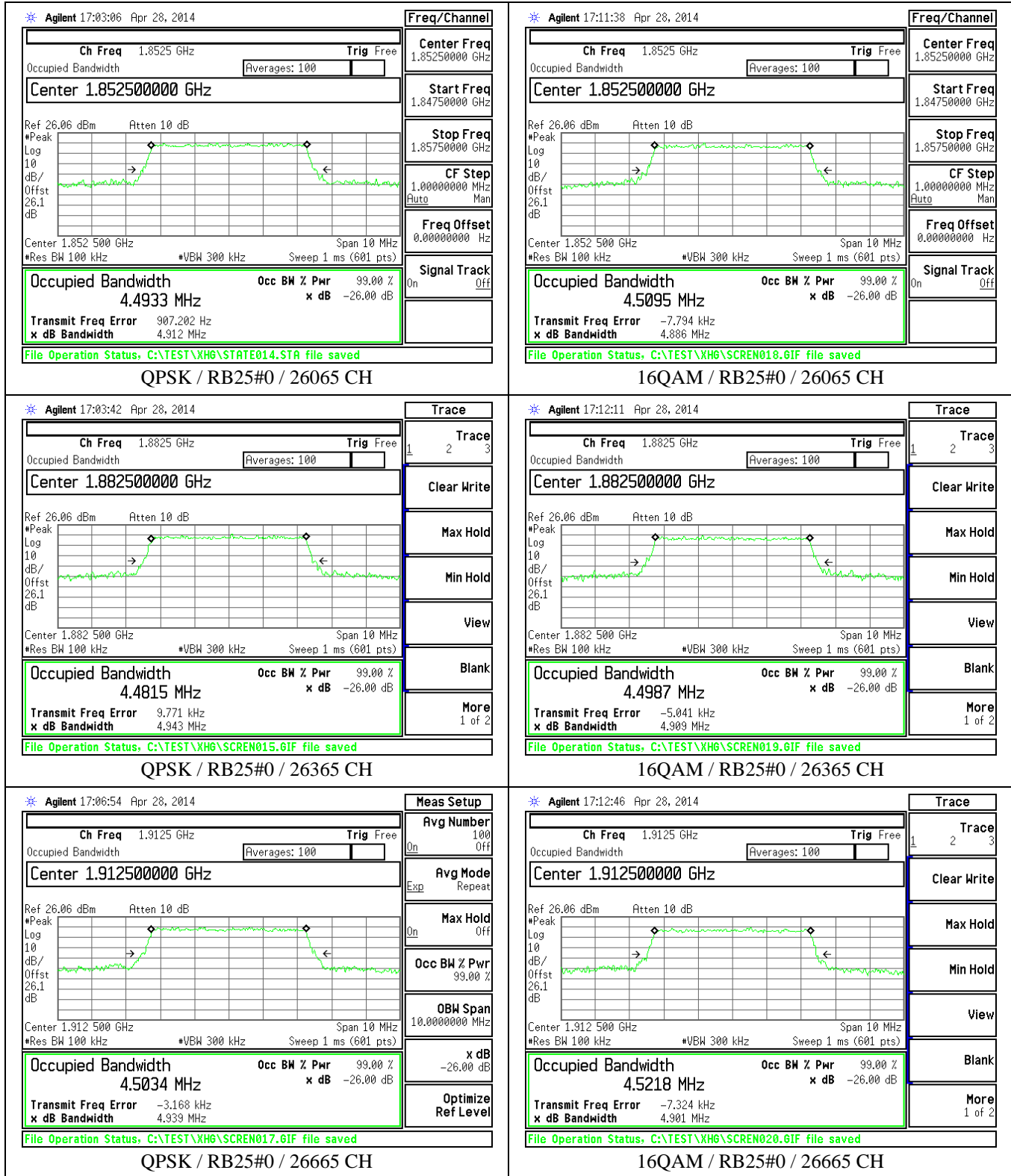

## 11. Band Edge Compliance

### 11.1 Definition

Power of any emission outside of the authorized operating frequency ranges must be attenuated below the transmitting power (P) by a factor of at least  $43 + 10 \log(P)$  dB. In the 1 MHz bands immediately outside and adjacent to the frequency block a resolution bandwidth of at least one percent of the emission bandwidth of the fundamental emission of the transmitter may be employed. The emission limit equal to  $-13\text{dBm}$ .

### 11.2 Test Procedure

- All measurements were done at low and high operational frequency range.
- The center frequency of spectrum is the band edge frequency and span is 1 MHz. The RBW of the spectrum is 100 KHz and the VBW of the spectrum is 300 KHz.
- Record the max trace plot into the test report.

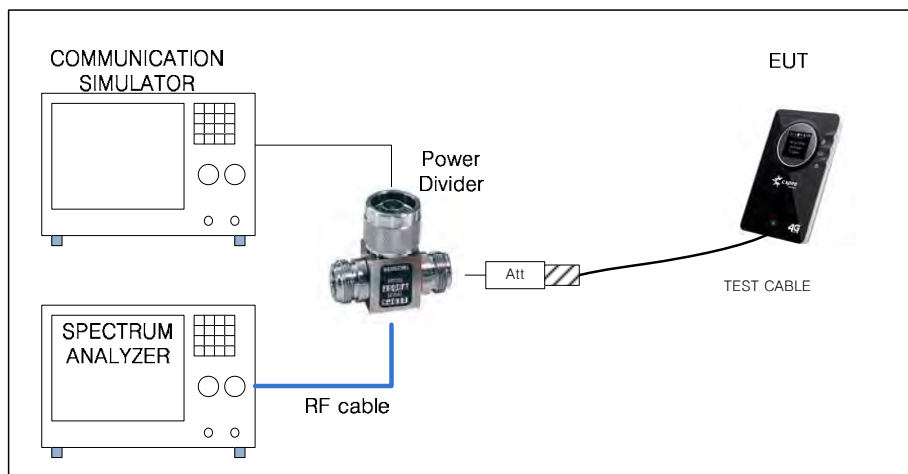

\* Simulator call mode : all bit up(Max Power)

\* TEST Cable : Connect LTE Antenna PORT (0.6dB loss / 30 cm / MCX to SMA Cable)

\* RF Cable : HUBER+SHUNER / SUCOFLEX 104 / DC-18 GHz / 1.0 m

\* Attenuator : 10 dB (Weinshel /56-10/ DC-28 GHz) + 10 dB(Weinshel / 56-10 / DC-28 GHz)

\* Power Divider : WEINSCHTEL / 1506A / DC-18 GHz / 3 Port

\* Path Loss Information

Frequency (MHz)	RF Cable (dB)	10 dB ATT (dB)	10 dB ATT (dB)	Power Diver (dB)	Test Cable (dB)	Total Loss (dB)
1 882.50	0.45	9.62	9.61	5.78	0.60	26.06

### 11.3 Test Criteria

At least  $-13\text{ dBm}$  below.

**11.4 Test Result**

Unit :dBm

Modulation	Resource Block Size	Resource Block Offset	Low ch : 26065	RBW / VBW / SPAN	High ch : 26665
			Freq(MHz) : 1 852.50		Freq(MHz) : 1 912.50
QPSK	<b>CENTER FREQUENCY</b>		1 850 MHz	-	1 915 MHz
	1	0	-14.26	100K/ 300K/ 6M	-53.89
	1	24	-53.96	100K/ 300K/ 6M	-16.29
	25	0	-22.14	100K/ 300K/ 6M	-24.25
16QAM	<b>CENTER FREQUENCY</b>		1 850 MHz	-	1 915 MHz
	1	0	-14.43	100K/ 300K/ 6M	-53.93
	1	24	-53.29	100K/ 300K/ 6M	-14.53
	25	0	-22.13	100K/ 300K/ 6M	-23.99

### 11.5 Test Plots

\* QPSK Modulation

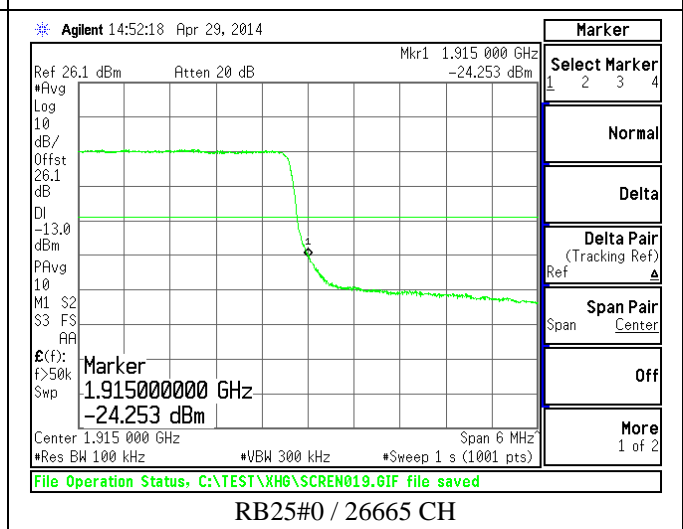
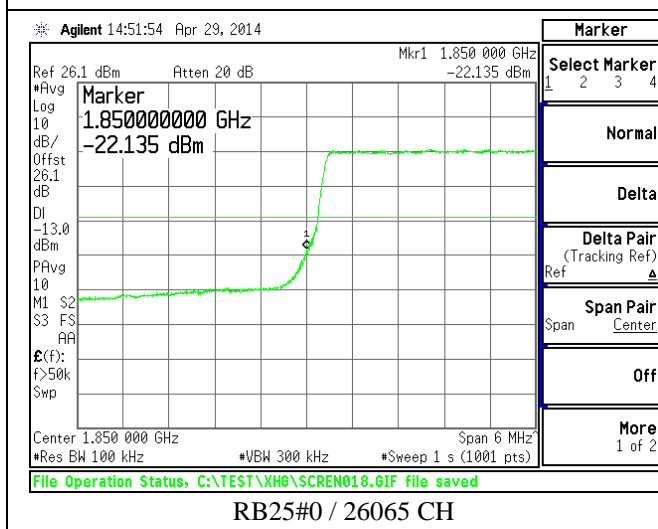
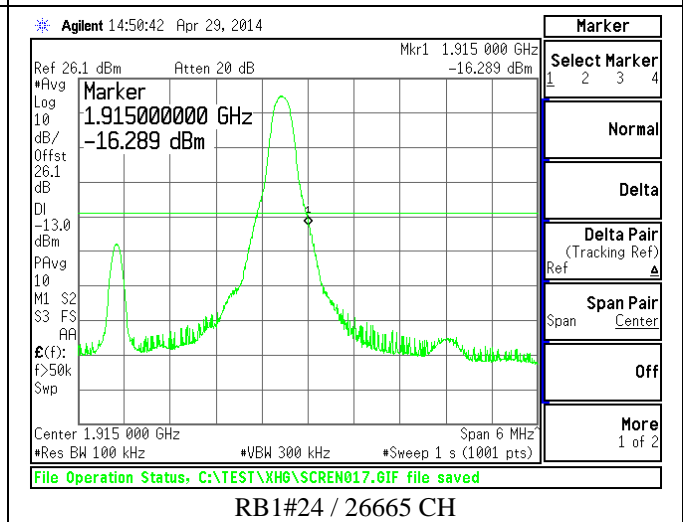
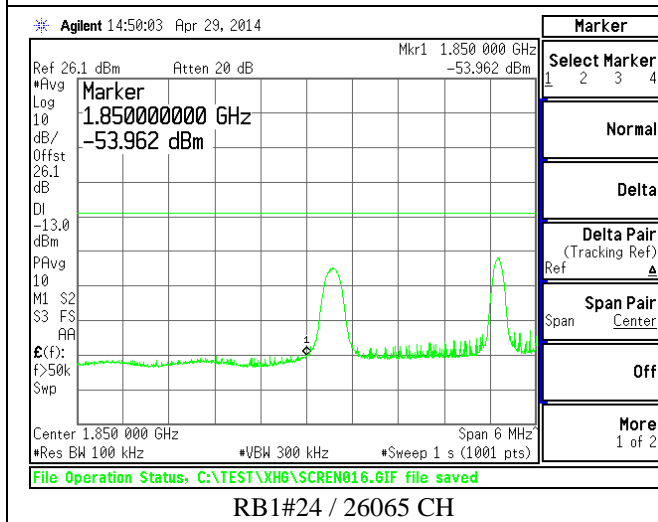
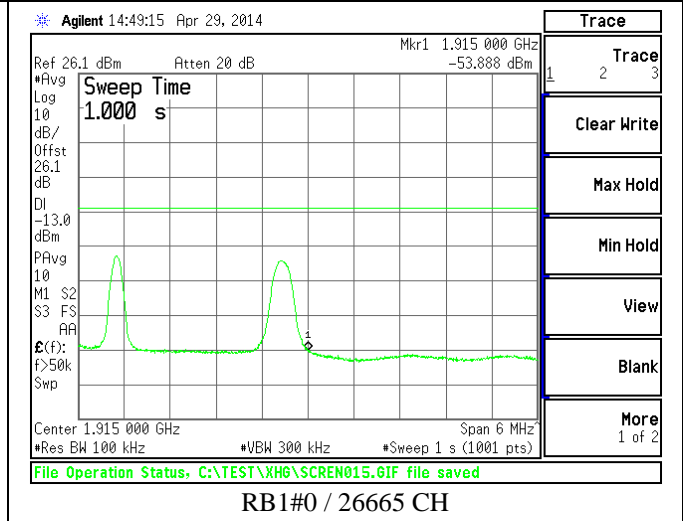
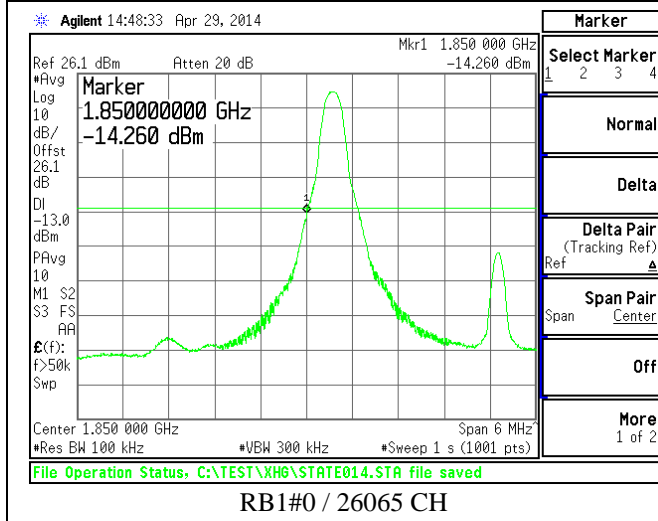

\* 16QAM Modulation

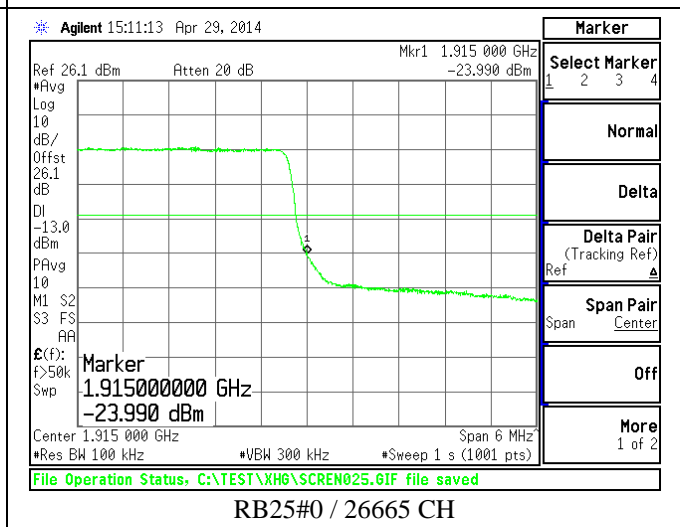
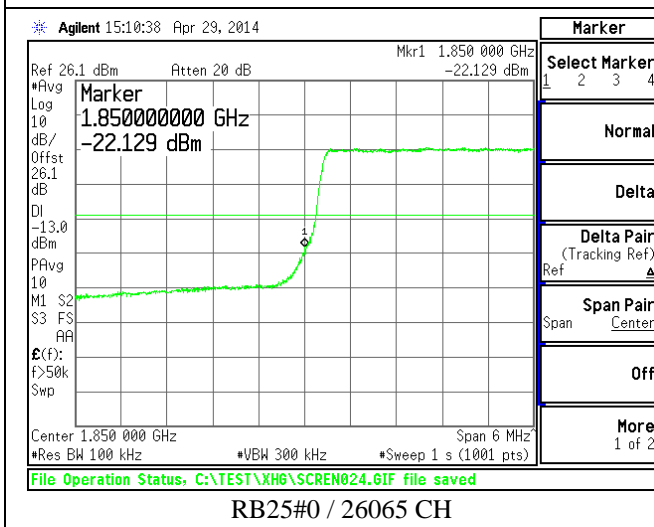
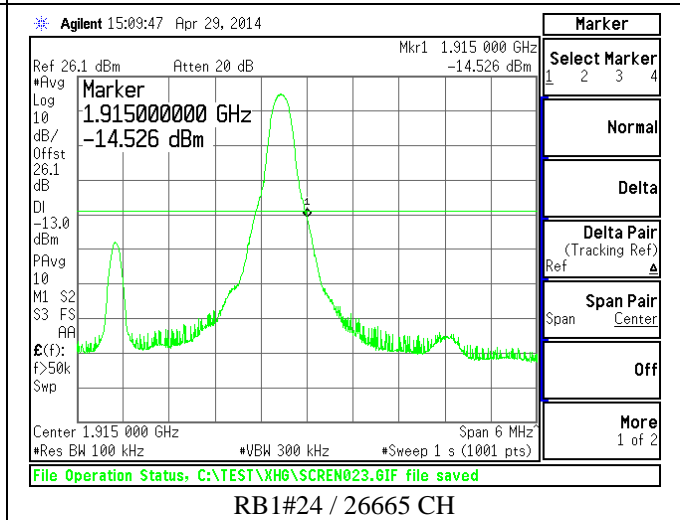
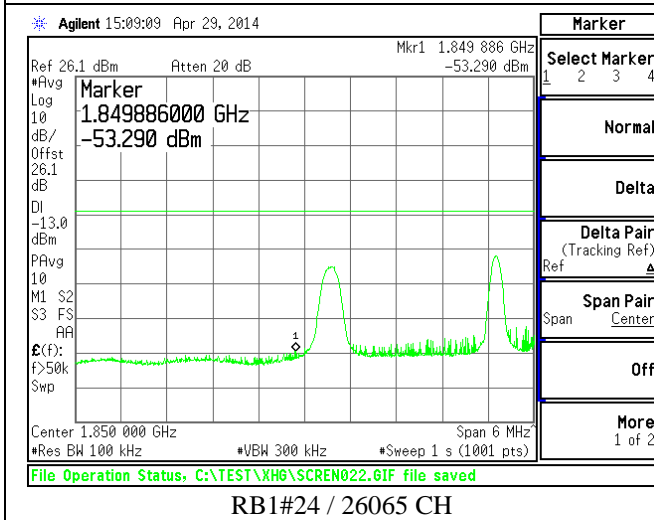
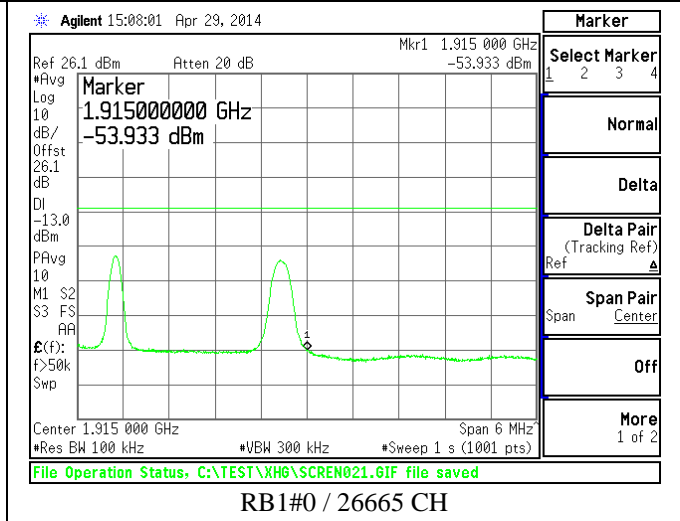
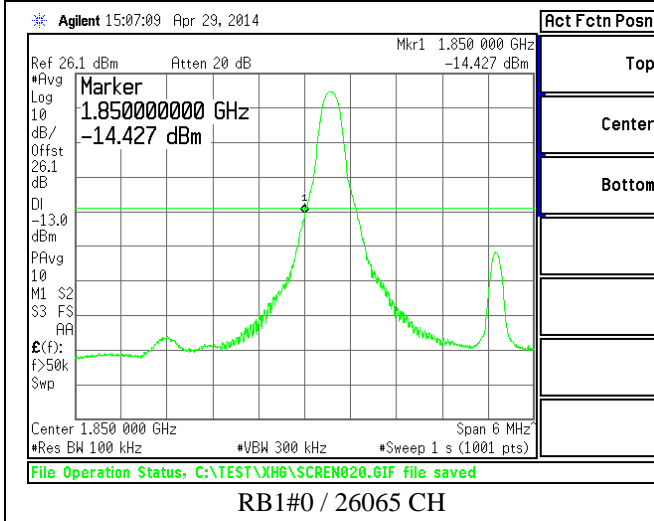

## 12. Spurious Emission at Antenna Terminals

### 12.1 Definition

The power of any emission outside of the authorized operating frequency ranges must be attenuated below the transmitting power (P) by a factor of at least  $43 + 10 \log(P)$  dB. The emission limit equal to  $-13$ dBm.

### 12.2 Test Procedure

- The EUT makes a phone call to the communication simulator. All measurements were done at middle frequency range.
- Measuring frequency range is from 30 MHz to 20GHz. The RBW=1MHz and VBW=3MHz is used for conducted emission measurement.(correct frequency attenuation level)
- Record the max trace plot into the test report.

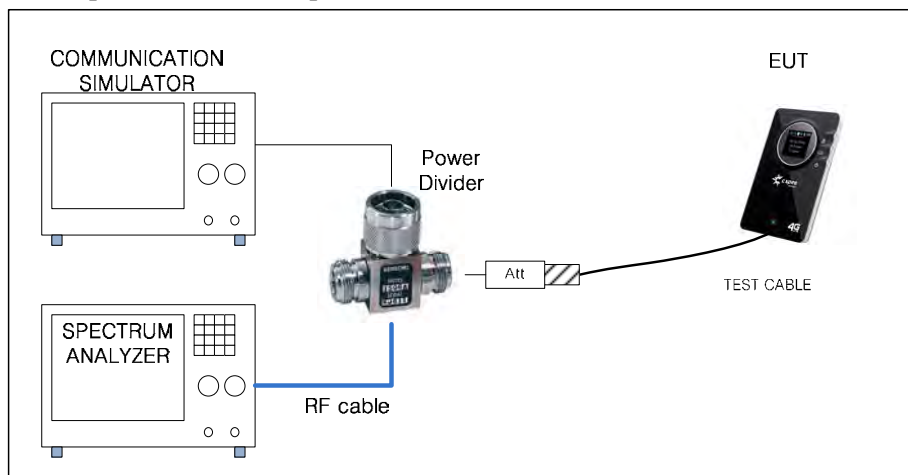

\* Simulator call mode : all bit up(Max Power)

\* TEST Cable : Connect LTE Antenna PORT (0.6dB loss / 30 cm / MCX to SMA Cable)

\* RF Cable : HUBER+SHUNER / SUCOFLEX 104 / DC-18 GHz / 1.0 m

\* Attenuator : 10 dB (Weinshel /56-10/ DC-28 GHz) + 10 dB(Weinshel / 56-10 / DC-28 GHz)

\* Power Divider : WEINSCHEL / 1506A / DC-18 GHz / 3 Port

\* Path Loss Information

Frequency (MHz)	RF Cable (dB)	10 dB ATT (dB)	10 dB ATT (dB)	Power Diver (dB)	Test Cable (dB)	Total Loss (dB)
1 882.50	0.45	9.62	9.61	5.78	0.60	26.06
7 522.10	0.88	9.79	9.74	5.83	0.60	26.84
7 527.00	0.88	9.79	9.74	5.83	0.60	26.84
7 539.20	0.88	9.79	9.74	5.84	0.60	26.85



**12.3 Test Result**

Unit : dBm

CH : 26365			FREQUENCY : 1 882.50 MHz			
Modulation	Resource Block Size	Resource Block Offset	Reading (dBm)	Measured Freq.(MHz)	Correct (Att, cable)	Result
QPSK	1	0	-47.55	7 522.10	0.78	-46.77
	1	24	-47.42	7 539.20	0.79	-46.63
	25	0	-51.90	7 527.00	0.79	-51.12
16QAM	1	0	-47.15	7 522.10	0.78	-46.37
	1	24	-47.31	7 539.20	0.79	-46.52
	25	0	-51.53	7 529.40	0.78	-50.75

### 12.4 Test Plots

\* CH: 26365 (1 882.50 MHz)

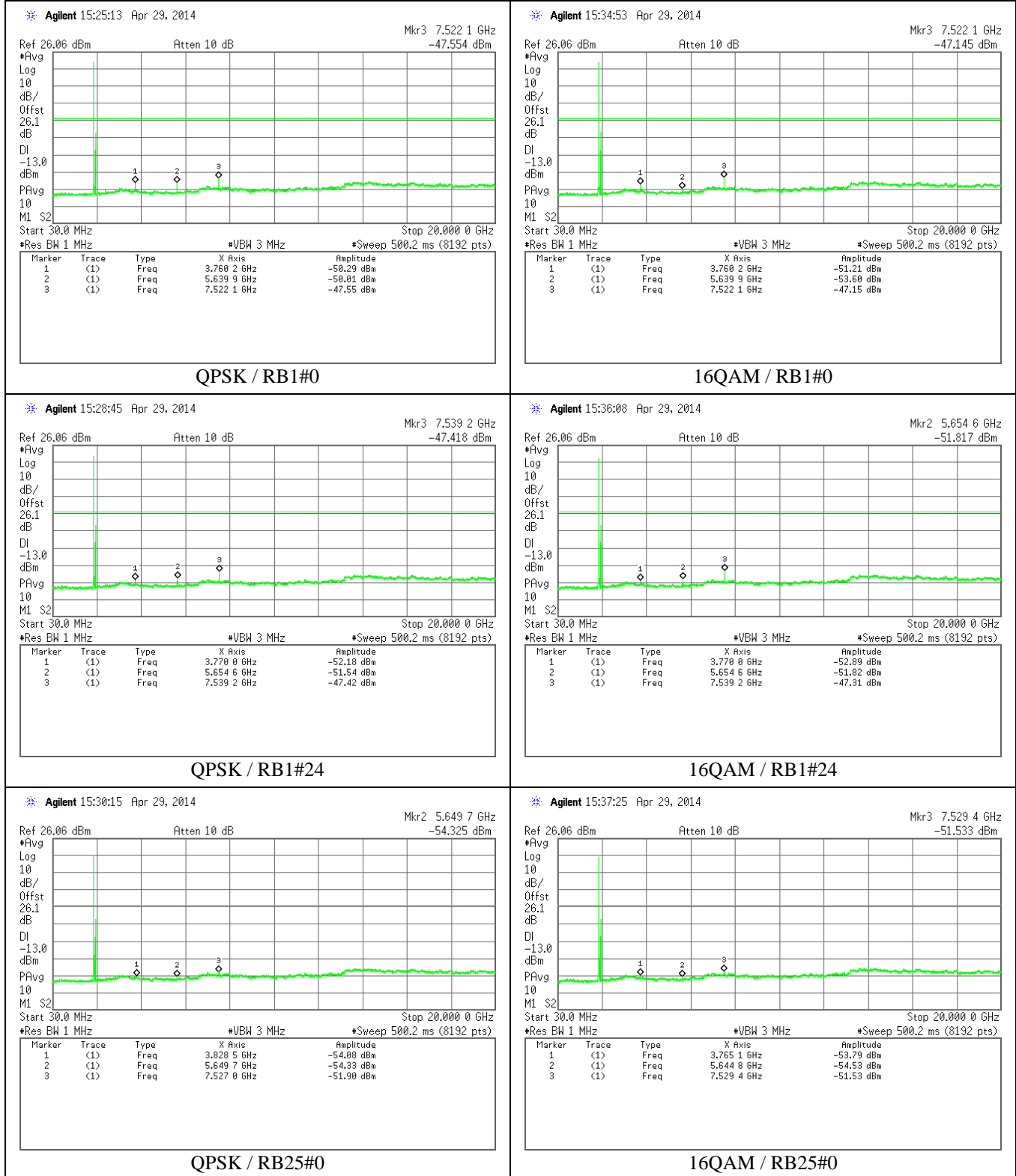

## 13. Field Strength of Spurious Radiation

### 13.1 Definition

The power of any emission outside of the authorized operating frequency ranges must be attenuated below the transmitting power (P) by a factor of at least  $43 + 10 \log(P)$  dB. The emission limit equal to  $-13$ dBm

### 13.2 Test Procedure

The EUT was placed on a non-conductive table 0.8 meters above the ground plane. The table was centered on a rotating turntable at a distance of 3 meters from the measurement antenna.

For spurious emissions below 1 GHz quasi-peak detection is used with a resolution bandwidth of 120 kHz. The emissions were maximized by rotating the EUT and raising and lowering the measurement antenna from 1~4 meters (above 1 GHz, measure antenna from 1 ~ 3.5 meters)

Spurious/harmonic emissions above 1 GHz peak are measured with average and peak detection with a resolution bandwidth of 1 MHz (VBW = 3 MHz) and measured at a distance of 3 meter.

Average detection is used to determine compliance of the EUT if the peak does not meet the average limit. Non-harmonic emissions must satisfy the average limit and the peak limit (20 dB above average).

Correction factor is a combination of cable loss (CL), microwave amplifier gain (G amp), antenna factor (AF), hi-pass filter factor (HPF)

Example correction factor calculation:  $F/S(\text{Field Strength}) = \text{Measuring Value} + \text{AF} - \text{G amp} + \text{CL} + \text{HPF}$

\* Hi-Pass Filter : WAINWRIGHT / WHK3.0/18G-10SS / 3.0-18 GHz pass filter

The EIRP limits in dBm were converted to field strength limits in  $\text{dB}\mu\text{V/m}$  @ 3m.

Example EIRP limit conversion:  $F/S(\text{Field Strength}) = \text{EIRP} + 95.2$

It was performed according to the KDB 971168 v02r01 5.8.3. Mathematical conversions.

Both vertical and horizontal polarities were tested and the worst case presented. In all cases the vertical polarization resulted in the greatest signal.

There were no measurable emissions above 18 GHz, up to 40 GHz. The measurement noise floor is well below the specified limit. Measurements in the table above for emissions greater than 18 GHz are of the noise floor.

### 13.3 Test Results

#### 13.3.1 mode : QPSK Modulation / RB1#0 / XY SCAN

Emission Frequency (MHz)	ANT (H/V)	EUT (X,Y,Z)	Measure Value (dBμV)	Antenna Factor [dB/m]	Amp Gain (dB)	Cable loss (dB)	High Pass Filter (dB)	F/S (dBμV/m)	EIRP (dBm)	Limit (dBm)	Margin (dB)
3759.00	V	XY	58.25	29.54	40.88	7.38	0.65	54.94	-40.26	-13.00	27.26
4791.00	V	XY	49.05	31.19	40.26	8.70	0.39	49.07	-46.13	-13.00	33.13
5643.00	V	XY	57.94	32.29	40.03	9.36	0.37	59.93	-35.27	-13.00	22.27
3759.00	H	XY	62.47	29.54	40.88	7.38	0.65	59.16	-36.04	-13.00	23.04
5643.00	H	XY	57.20	32.29	40.03	9.36	0.37	59.19	-36.01	-13.00	23.01

#### 13.3.2 mode : QPSK Modulation / RB1#24 / XY SCAN

Emission Frequency (MHz)	ANT (H/V)	EUT (X,Y,Z)	Measure Value (dBμV)	Antenna Factor [dB/m]	Amp Gain (dB)	Cable loss (dB)	High Pass Filter (dB)	F/S (dBμV/m)	EIRP (dBm)	Limit (dBm)	Margin (dB)
3768.00	V	XY	67.97	29.56	40.88	7.39	0.64	64.68	-30.52	-13.00	17.52
5238.00	V	XY	50.91	31.82	40.03	9.04	0.37	52.11	-43.09	-13.00	30.09
5655.00	V	XY	64.21	32.30	40.02	9.37	0.37	66.23	-28.97	-13.00	15.97
3768.00	H	XY	67.16	29.56	40.88	7.39	0.64	63.87	-31.33	-13.00	18.33
5655.00	H	XY	61.40	32.30	40.02	9.37	0.37	63.42	-31.78	-13.00	18.78

13.3.3 mode : QPSK Modulation / RB1#0 / YZ SCAN

Emission Frequency (MHz)	ANT (H/V)	EUT (X,Y,Z)	Measure Value (dBμV)	Antenna Factor [dB/m]	Amp Gain (dB)	Cable loss (dB)	High Pass Filter (dB)	F/S (dBμV/m)	EIRP (dBm)	Limit (dBm)	Margin (dB)
3759.00	V	YZ	63.34	29.54	40.88	7.38	0.65	60.03	-35.17	-13.00	22.17
5643.00	V	YZ	61.22	32.29	40.03	9.36	0.37	63.21	-31.99	-13.00	18.99
3759.00	H	YZ	58.27	29.54	40.88	7.38	0.65	54.96	-40.24	-13.00	27.24
4587.00	H	YZ	59.15	30.83	40.54	8.52	0.42	58.38	-36.82	-13.00	23.82
5643.00	H	YZ	60.42	32.29	40.03	9.36	0.37	62.41	-32.79	-13.00	19.79

13.3.4 mode : QPSK Modulation / RB1#24 / YZ SCAN

Emission Frequency (MHz)	ANT (H/V)	EUT (X,Y,Z)	Measure Value (dBμV)	Antenna Factor [dB/m]	Amp Gain (dB)	Cable loss (dB)	High Pass Filter (dB)	F/S (dBμV/m)	EIRP (dBm)	Limit (dBm)	Margin (dB)
3768.00	V	YZ	66.90	29.56	40.88	7.39	0.64	63.61	-31.59	-13.00	18.59
5655.00	V	YZ	65.74	32.30	40.02	9.37	0.37	67.76	-27.44	-13.00	14.44
3768.00	H	YZ	65.46	29.56	40.88	7.39	0.64	62.17	-33.03	-13.00	20.03
5655.00	H	YZ	60.69	32.30	40.02	9.37	0.37	62.71	-32.49	-13.00	19.49

13.3.5 mode : QPSK Modulation / RB1#0 / ZX SCAN

Emission Frequency (MHz)	ANT (H/V)	EUT (X,Y,Z)	Measure Value (dBμV)	Antenna Factor [dB/m]	Amp Gain (dB)	Cable loss (dB)	High Pass Filter (dB)	F/S (dBμV/m)	EIRP (dBm)	Limit (dBm)	Margin (dB)
3759.00	V	ZX	59.79	29.54	40.88	7.38	0.65	56.48	-38.72	-13.00	25.72
5643.00	V	ZX	57.75	32.29	40.03	9.36	0.37	59.74	-35.46	-13.00	22.46
3759.00	H	ZX	59.47	29.54	40.88	7.38	0.65	56.16	-39.04	-13.00	26.04
5643.00	H	ZX	57.97	32.29	40.03	9.36	0.37	59.96	-35.24	-13.00	22.24

13.3.6 mode : QPSK Modulation / RB1#24 / ZX SCAN

Emission Frequency (MHz)	ANT (H/V)	EUT (X,Y,Z)	Measure Value (dBμV)	Antenna Factor [dB/m]	Amp Gain (dB)	Cable loss (dB)	High Pass Filter (dB)	F/S (dBμV/m)	EIRP (dBm)	Limit (dBm)	Margin (dB)
3768.00	V	ZX	58.03	29.56	40.88	7.39	0.64	54.74	-40.46	-13.00	27.46
5655.00	V	ZX	56.54	32.30	40.02	9.37	0.37	58.56	-36.64	-13.00	23.64
3768.00	H	ZX	60.65	29.56	40.88	7.39	0.64	57.36	-37.84	-13.00	24.84
5655.00	H	ZX	58.46	32.30	40.02	9.37	0.37	60.48	-34.72	-13.00	21.72

13.3.7 mode : 16QAM Modulation / RB1#0 / XY SCAN

Emission Frequency (MHz)	ANT (H/V)	EUT (X,Y,Z)	Measure Value (dBμV)	Antenna Factor [dB/m]	Amp Gain (dB)	Cable loss (dB)	High Pass Filter (dB)	F/S (dBμV/m)	EIRP (dBm)	Limit (dBm)	Margin (dB)
3759.00	V	XY	67.91	29.54	40.88	7.38	0.65	64.60	-30.60	-13.00	17.60
5643.00	V	XY	62.88	32.29	40.03	9.36	0.37	64.87	-30.33	-13.00	17.33
3759.00	H	XY	71.24	29.54	40.88	7.38	0.65	67.93	-27.27	-13.00	14.27
5643.00	H	XY	62.25	32.29	40.03	9.36	0.37	64.24	-30.96	-13.00	17.96

13.3.8 mode : 16QAM Modulation / RB1#24 / XY SCAN

Emission Frequency (MHz)	ANT (H/V)	EUT (X,Y,Z)	Measure Value (dBμV)	Antenna Factor [dB/m]	Amp Gain (dB)	Cable loss (dB)	High Pass Filter (dB)	F/S (dBμV/m)	EIRP (dBm)	Limit (dBm)	Margin (dB)
3768.00	V	XY	69.56	29.54	40.88	7.39	0.64	66.25	-28.95	-13.00	15.95
5655.00	V	XY	67.39	32.30	40.02	9.37	0.37	69.41	-25.79	-13.00	12.79
3768.00	H	XY	71.75	29.56	40.88	7.39	0.64	68.46	-26.74	-13.00	13.74
5655.00	H	XY	61.74	32.30	40.02	9.37	0.37	63.76	-31.44	-13.00	18.44

13.3.9 mode : 16QAM Modulation / RB1#0 / YZ SCAN

Emission Frequency (MHz)	ANT (H/V)	EUT (X,Y,Z)	Measure Value (dBμV)	Antenna Factor [dB/m]	Amp Gain (dB)	Cable loss (dB)	High Pass Filter (dB)	F/S (dBμV/m)	EIRP (dBm)	Limit (dBm)	Margin (dB)
3759.00	V	YZ	66.83	29.54	40.88	7.38	0.65	63.52	-31.68	-13.00	18.68
5643.00	V	YZ	63.31	32.29	40.03	9.36	0.37	65.30	-29.90	-13.00	16.90
3759.00	H	YZ	67.52	29.54	40.88	7.38	0.65	64.21	-30.99	-13.00	17.99
5643.00	H	YZ	65.21	32.29	40.03	9.36	0.37	67.20	-28.00	-13.00	15.00

13.3.10 mode : 16QAM Modulation / RB1#24 / YZ SCAN

Emission Frequency (MHz)	ANT (H/V)	EUT (X,Y,Z)	Measure Value (dBμV)	Antenna Factor [dB/m]	Amp Gain (dB)	Cable loss (dB)	High Pass Filter (dB)	F/S (dBμV/m)	EIRP (dBm)	Limit (dBm)	Margin (dB)
3768.00	V	YZ	68.73	29.56	40.88	7.39	0.64	65.44	-29.76	-13.00	16.76
5655.00	V	YZ	65.66	32.30	40.02	9.37	0.37	67.68	-27.52	-13.00	14.52
3768.00	H	YZ	67.76	29.56	40.88	7.39	0.64	64.47	-30.73	-13.00	17.73
5655.00	H	YZ	63.37	32.30	40.02	9.37	0.37	65.39	-29.81	-13.00	16.81



13.3.11 mode : 16QAM Modulation / RB1#0 / ZX SCAN

Emission Frequency (MHz)	ANT (H/V)	EUT (X,Y,Z)	Measure Value (dBμV)	Antenna Factor [dB/m]	Amp Gain (dB)	Cable loss (dB)	High Pass Filter (dB)	F/S (dBμV/m)	EIRP (dBm)	Limit (dBm)	Margin (dB)
3759.00	V	ZX	59.52	29.54	40.88	7.38	0.65	56.21	-38.99	-13.00	25.99
5643.00	V	ZX	56.29	32.29	40.03	9.36	0.37	58.28	-36.92	-13.00	23.92
3759.00	H	ZX	59.88	29.54	40.88	7.38	0.65	56.57	-38.63	-13.00	25.63
5643.00	H	ZX	55.70	32.29	40.03	9.36	0.37	57.69	-37.51	-13.00	24.51

13.3.12 mode : 16QAM Modulation / RB1#24 / ZX SCAN

Emission Frequency (MHz)	ANT (H/V)	EUT (X,Y,Z)	Measure Value (dBμV)	Antenna Factor [dB/m]	Amp Gain (dB)	Cable loss (dB)	High Pass Filter (dB)	F/S (dBμV/m)	EIRP (dBm)	Limit (dBm)	Margin (dB)
3768.00	V	ZX	57.44	29.56	40.88	7.39	0.64	54.15	-41.05	-13.00	28.05
5655.00	V	ZX	56.11	32.30	40.02	9.37	0.37	58.13	-37.07	-13.00	24.07
3768.00	H	ZX	59.81	29.56	40.88	7.39	0.64	56.52	-38.68	-13.00	25.68
5655.00	H	ZX	57.98	32.30	40.02	9.37	0.37	60.00	-35.20	-13.00	22.20

## 14. Frequency Stability

### 14.1 Definition

The frequency stability shall be sufficient to ensure that the fundamental emission stays within the authorized frequency block

### 14.2 Test Procedure

- Device is placed at the Temp & Humidity Chamber. Power warm up is at least 15 min and power applied should perform before recording frequency error.
- EUT is connected the external power supply to control the DC input power. The test voltage range is from minimum to maximum working voltage. Each step shall be record the frequency error rate.
- The temperature range step is 10 degrees in this test items. All temperature levels shall be hold the  $\pm 0.5^\circ\text{C}$  during the measurement testing. The each temperature step shall be at least 0.5 hours, consider the EUT could be test under the stability condition

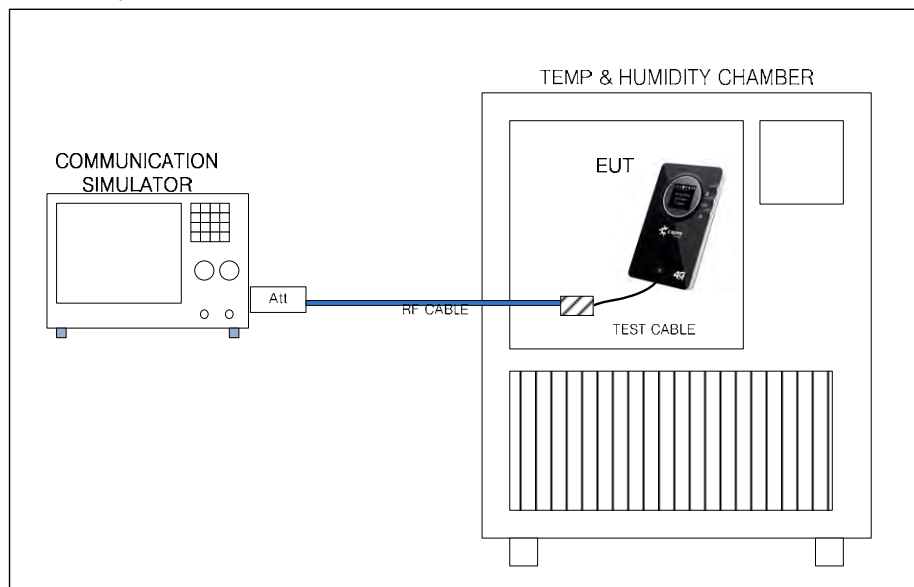

- \* EUT test mode : QPSK Modulation / RB1#0 / 26365 CH(1 882.50 MHz)
- \* Temp is change -30 degree to +50 degree (10 degree step)
- \* Volt is change DC 3.0V(Cut Off Voltage) to DC 4.3V( Normal Volt : DC 3.7 V +115%)
- \* Temp&Humidity chamber : BUMJIN / BJ-THC-667L / 201203-JNDL/ -40°C~+150°C / Due to Cal: 2015-03-24
- \* DC Power Supply : Agilent / E3630A / MY40004023 / 0 ~ 24V / 0 ~ 2.5A / Due to Cal: 2014-10-15

### 14.3 Test Results

#### 14.3.1 Frequency error vs. Temperature

Temp (degree)	Measure (Hz)	Measure (ppm)	Limit (ppm)
-30.0	15.79	0.008	2.5
-20.0	3.60	0.002	2.5
-10.0	-8.60	-0.005	2.5
0.0	9.01	0.005	2.5
10.0	15.06	0.008	2.5
20.0	7.67	0.004	2.5
30.0	-14.61	-0.008	2.5
40.0	9.94	0.005	2.5
50.0	9.36	0.005	2.5

#### 14.3.2 Frequency error vs. Voltage

Voltage (V)	Measure (Hz)	Measure (ppm)	Limit (ppm)
3.0	-16.31	-0.009	2.5
3.7	-9.58	-0.005	2.5
4.3	-12.73	-0.007	3.5

\* Measure (ppm) = Measure (Hz)  $\div$  1 882.50 MHz

## 14.4 Test Plots

### 14.4.1 Frequency error vs. Temperature

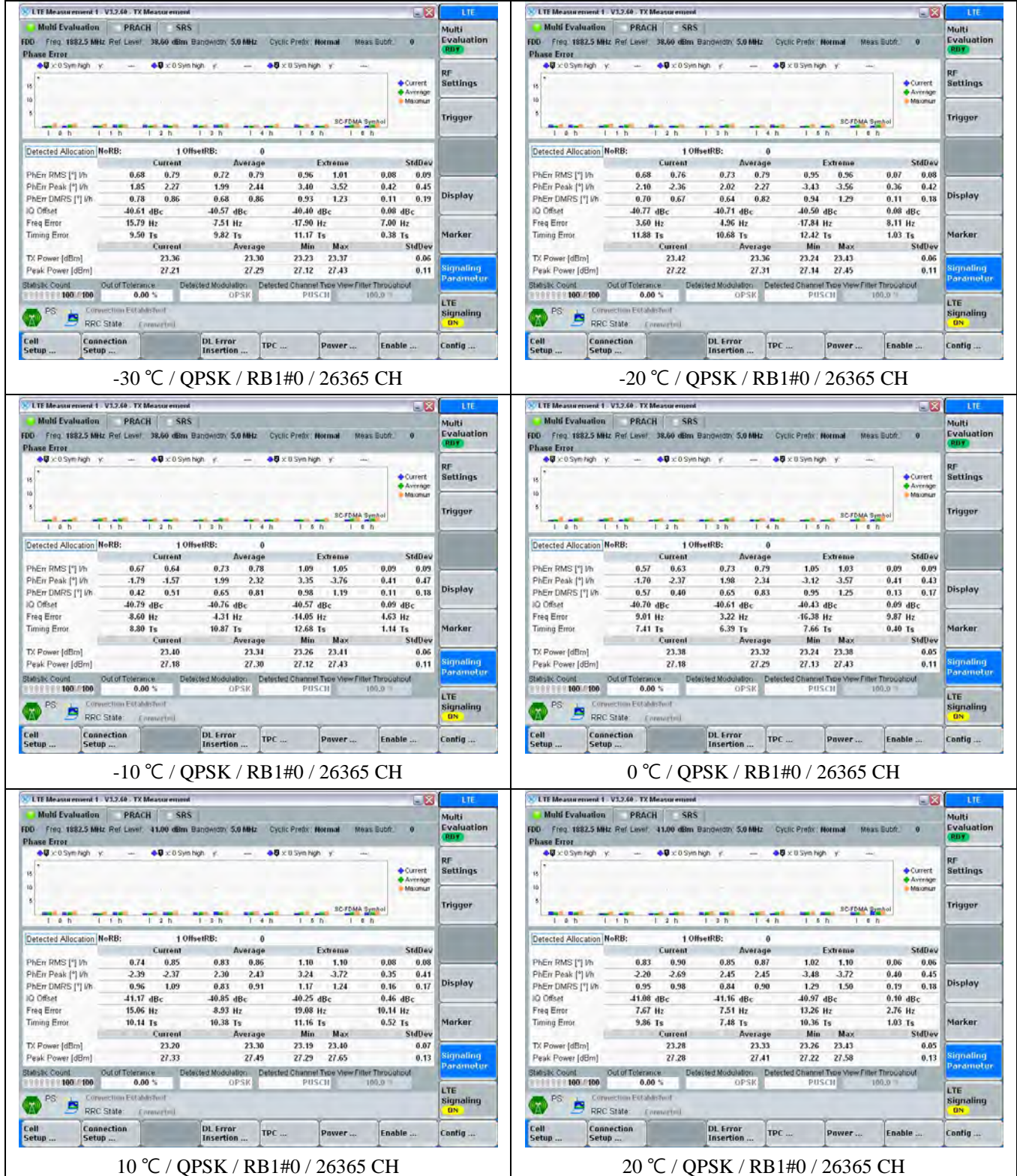



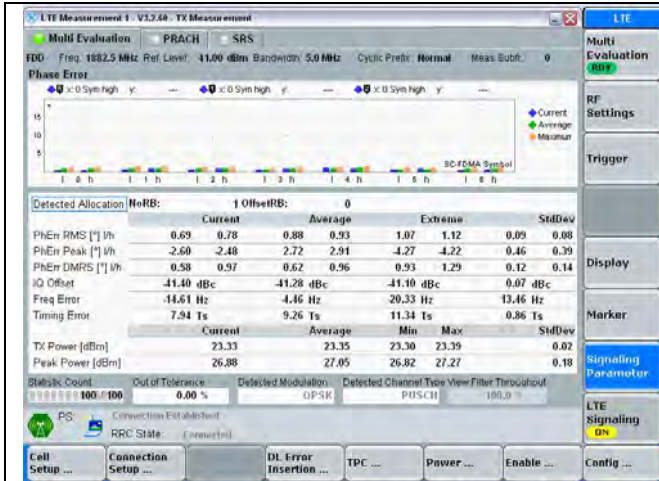

30 °C / QPSK / RB1#0 / 26365 CH

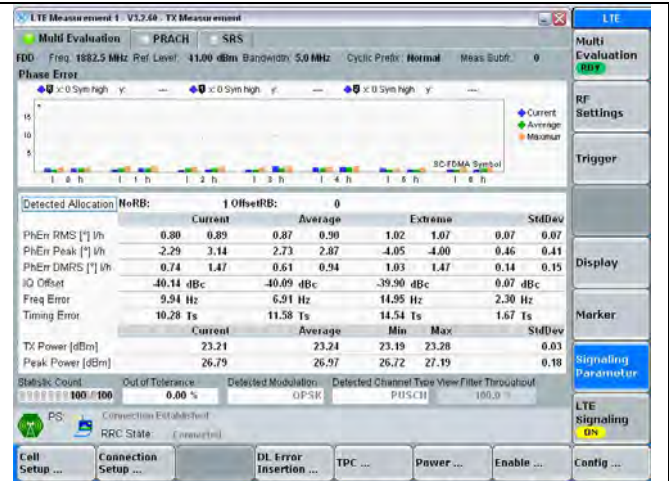

40 °C / QPSK / RB1#0 / 26365 CH



50 °C / QPSK / RB1#0 / 26365 CH

-BLANK-



### 14.4.2 Frequency error vs. Voltage

