

# TEST REPORT

of

FCC Part 15 Subpart E §15.407

FCC ID: XHG-R717V

1. Equipment Under Test : Mobile Hotspot
2. Model Name : R717V
3. Variant Model Name(s) : -
4. Applicant : Franklin Technology Inc.
5. Manufacturer : Franklin Technology Inc.
6. Date of Receipt : 2020.06.26
7. Date of Test(s) : 2020.07.23 ~ 2020.09.15
8. Date of Issue : 2020.09.17

In the configuration tested, the EUT complied with the standards specified above. This test report does not assure KOLAS accreditation.

- 1) The results of this test report are effective only to the items tested.
- 2) The SGS Korea is not responsible for the sampling, the results of this test report apply to the sample as received.

Tested by:



Nancy Park

Technical  
Manager:



Hyunchoe You

**SGS Korea Co., Ltd. Gunpo Laboratory**



# INDEX

## Table of contents

1. General Information -----	3
2. Transmitter Radiated Spurious Emissions -----	10
3. 26 dB Bandwidth & 99 % Bandwidth -----	26
4. 6 dB Bandwidth -----	35
5. Maximum Conducted Output Power -----	39
6. Peak Power Spectral Density -----	43
7. AC Power Line Conducted Emission -----	51
8. Antenna Requirement -----	55

## 1. General Information

### 1.1. Testing Laboratory

SGS Korea Co., Ltd. (Gunpo Laboratory)

- 10-2, LS-ro 182beon-gil, Gunpo-si, Gyeonggi-do, Korea, 15807
- 4, LS-ro 182beon-gil, Gunpo-si, Gyeonggi-do, Korea, 15807
- Designation number: KR0150

All SGS services are rendered in accordance with the applicable SGS conditions of service available on request and accessible at <http://www.sgs.com/en/Terms-and-Conditions.aspx>.

Phone No. : +82 31 688 0901

Fax No. : +82 31 688 0921

### 1.2. Details of Applicant

Applicant : Franklin Technology Inc.

Address : 906 JEI Platz, 186, Gasan digital 1-ro, Gumcheon-Gu, Seoul, South Korea, 08502

Contact Person : Lee, James

Phone No. : +82 70 8228 6445

### 1.3. Details of Manufacturer

Company : Same as applicant

Address : Same as applicant

### 1.4. Description of EUT

<b>Kind of Product</b>	Mobile Hotspot
<b>Model Name</b>	R717V
<b>Power Supply</b>	DC 3.8 V
<b>Frequency Range</b>	5 180 MHz ~ 5 240 MHz (Band 1: 11n_HT20) 5 190 MHz ~ 5 230 MHz (Band 1: 11n_HT40) 5 745 MHz ~ 5 825 MHz (Band 3: 11ac_VHT20) 5 755 MHz ~ 5 795 MHz (Band 3: 11ac_VHT40) 5 775 MHz (Band 3: 11ac_VHT80)
<b>Modulation Technique</b>	OFDM
<b>Number of Channels</b>	4 channels (Band 1: 11n_HT20) 2 channels (Band 1: 11n_HT40) 5 channels (Band 3: 11ac_VHT20) 2 channels (Band 3: 11ac_VHT40) 1 channel (Band 3: 11ac_VHT80)
<b>Antenna Type</b>	FPCB + Carrier type antenna
<b>Antenna Gain</b>	5 150 MHz ~ 5 250 MHz: 4.69 dB i 5 725 MHz ~ 5 850 MHz: 3.00 dB i

### 1.5. Test Equipment List

Equipment	Manufacturer	Model	S/N	Cal. Date	Cal. Interval	Cal. Due
Signal Generator	Agilent	SMR40	100272	Jun. 18, 2020	Annual	Jun. 18, 2021
Signal Generator	Agilent	SMBV100A	255834	Jun. 03, 2020	Annual	Jun. 03, 2021
Spectrum Analyzer	R&S	FSV30	103455	Dec. 22, 2019	Annual	Dec. 22, 2020
Spectrum Analyzer	Agilent	N9020A	MY53421758	Sep. 04, 2020	Annual	Sep. 04, 2021
Spectrum Analyzer	Agilent	N9030A	US51350132	Nov. 15, 2019	Annual	Nov. 15, 2020
Power Meter	Anritsu	ML2495A	1223004	Jun. 01, 2020	Annual	Jun. 01, 2021
Power Sensor	Anritsu	MA2411B	1207272	Jun. 01, 2020	Annual	Jun. 01, 2021
Attenuator	AEROFLEX / INMET	40AH2W-10	40G-3	Jun. 16, 2020	Annual	Jun. 16, 2021
Low Pass Filter	Mini-Circuits	NLP-1200+	V 9500401023-3	Jun. 01, 2020	Annual	Jun. 01, 2021
High Pass Filter	Wainwright Instrument GmbH	WHKX6.0/18G-10SS	51	Jun. 07, 2020	Annual	Jun. 07, 2021
High Pass Filter	Wainwright Instrument GmbH	WHNX7.5/26.5G-6SS	11	May 18, 2020	Annual	May 18, 2021
DC Power Supply	Agilent	U8002A	MY49030063	Feb. 03, 2020	Annual	Feb. 03, 2021
Preamplifier	H.P.	8447F	2944A03909	Aug. 06, 2020	Annual	Aug. 06, 2021
Signal Conditioning Unit	R&S	SCU-18	10117	Jun. 10, 2020	Annual	Jun. 10, 2021
Preamplifier	MITEQ Inc.	JS44-18004000-35-8P	1546891	May 08, 2020	Annual	May 08, 2021
Loop Antenna	Schwarzbeck Mess-Elektronik	FMZB 1519	1519-039	Aug. 22, 2019	Biennial	Aug. 22, 2021
Bilog Antenna	Schwarzbeck Mess-Elektronik	VULB 9163	396	Mar. 21, 2019	Biennial	Mar. 21, 2021
Horn Antenna	R&S	HF906	100326	Feb. 14, 2020	Annual	Feb. 14, 2021
Horn Antenna	Schwarzbeck Mess-Elektronik	BBHA 9170	9170-540	Jul. 24, 2019	Biennial	Jul. 24, 2021
Test Receiver	R&S	ESU26	100109	Feb. 18, 2020	Annual	Feb. 18, 2021
Test Receiver	R&S	ESCI 7	100911	Feb. 19, 2020	Annual	Feb. 19, 2021
Two-Line V-Network	R&S	ENV216	100190	May 08, 2020	Annual	May 08, 2021
Turn Table	Innco systems GmbH	DS 1200 S	N/A	N.C.R.	N/A	N.C.R.
Controller	Innco systems GmbH	CONTROLLER CO3000-4P	CO3000/963/383 30516/L	N.C.R.	N/A	N.C.R.
Antenna Mast	Innco systems GmbH	MA4640-XP-ET	MA4640/536/383 30516/L	N.C.R.	N/A	N.C.R.
Shield Room	SY Corporation	L x W x H (6.5 m x 3.5 m x 3.5 m)	N/A	N.C.R.	N/A	N.C.R.
Anechoic Chamber	SY Corporation	L x W x H (9.6 m x 6.4 m x 6.6 m)	N/A	N.C.R.	N/A	N.C.R.
Coaxial Cable	RFONE	SFX086-NMNM-5M (5m)	20200323001	Aug. 10, 2020	Semi-annual	Feb. 10, 2021
Coaxial Cable	RFONE	PL520-NMNM-10M (10 m)	20200324001	Aug. 10, 2020	Semi-annual	Feb. 10, 2021
Coaxial Cable	Rosenberger	LA1-C006-1500	131014 10/20	Aug. 21, 2020	Semi-annual	Feb. 21, 2021

### 1.6. Summary of Test Result

The EUT has been tested according to the following specifications:

APPLIED STANDARD: FCC Part 15 Subpart E		
Section	Test Item(s)	Result
15.205(a) 15.209(a) 15.407(b)(1) 15.407(b)(4)	Transmitter Radiated Spurious Emissions	Complied
15.407(a)	26 dB Bandwidth & 99 % Bandwidth	Complied
15.407(e)	6 dB Bandwidth	Complied
15.407(a)(1) 15.407(a)(3)	Maximum Conducted Output Power	Complied
15.407(a)(1) 15.407(a)(3)	Peak Power Spectral Density	Complied
15.207	AC Power Line Conducted Emission	Complied

### 1.7. Test Procedure(s)

The measurement procedures described in the American National Standard of Procedures for Compliance Testing of unlicensed Wireless Devices (ANSI C63.10-2013) and the guidance provided in KDB 789033 D02 General UNII Test Procedures New Rules v02r01 were used in the measurement of the DUT.

### 1.8. Sample Calculation

Where relevant, the following sample calculation is provided:

#### 1.8.1. Conducted Test

$$\text{Offset value (dB)} = \text{Attenuator (dB)} + \text{Cable loss (dB)}$$

#### 1.8.2. Radiation Test

$$\text{Field strength level (dB}\mu\text{V/m)} = \text{Measured level (dB}\mu\text{V)} + \text{Antenna factor (dB)} + \text{Cable loss (dB)} - \text{Amplifier gain (dB)} + \text{Duty factor (dB)}$$

## 1.9. Measurement Uncertainty

Where relevant, the following measurement uncertainty levels have been estimated for tests performed on the apparatus:

Parameter	Uncertainty
RF Output Power	± 0.34 dB
Occupied Bandwidth	± 9.66 kHz
Power Spectral Density	± 0.61 dB
Conducted Spurious Emission	± 0.76 dB
AC Conducted Emission	± 3.45 dB
Radiated Emission, 9 kHz to 30 MHz	± 3.59 dB
Radiated Emission, below 1 GHz	± 5.88 dB
Radiated Emission, above 1 GHz	± 5.94 dB

Uncertainty figures are valid to a confidence level of 95 %.

## 1.10. Automatically Discontinue Transmission

### 1.10.1. Limit of Automatically Discontinue Transmission

The device shall automatically discontinue transmission in case of either absence of information to transmit or operating failure. These provisions are not intended to preclude the transmission of control or signaling information or the use of repetitive codes used by certain digital technologies to complete frame or burst intervals. Applicants shall include in their application for equipment authorization to describe how this requirement is met.

### 1.10.2. Test Result of Automatically Discontinue Transmission

While the EUT is not transmitting any information, the EUT can automatically discontinue transmission and become standby mode for power saving. The EUT can detect the controlling signal of ACK message transmitting from remote device and verify whether it shall resend or discontinue transmission.

## 1.11. Test Report Revision

Revision	Report Number	Date of Issue	Description
0	F690501-RF-RTL001178	2020.09.17	Initial

### 1.12. Duty Cycle of EUT

Regarding to KDB 789033 D02 General UNII Test Procedures New Rules v02r01, II.B, the maximum duty cycles of all modes were investigated and set the spectrum analyzer as below.

Set RBW ≥ EBW if possible; otherwise, set RBW to the largest available value, Set VBW ≥ RBW.

Set detector = peak or average. The zero-span measurement method shall not be used unless both RBW and VBW are > 50/T and the number of sweep points across duration T exceeds 100.

Mode	Data Rate (Mbps)	Duty Cycle (%)	Correction Factor (dB)
11n_HT20	MCS0	91.03	0.41
11n_HT40	MCS0	84.62	0.73
11ac_VHT20	MCS0	91.78	0.37
11ac_VHT40	MCS0	85.72	0.67
11ac_VHT80	MCS0	73.03	1.36

**Remark;**

- As measured duty cycles of EUT, all of mode and data rate keep constant period and are converted to log scale (power averaging) to compensate correction factor to result of average test items.
- Duty Cycle (%) = (Tx on time / Tx on + off time) x 100
- Correction Factor (dB) = 10 log (1 / Duty Cycle)

**- Test plots**

802.11n\_HT20

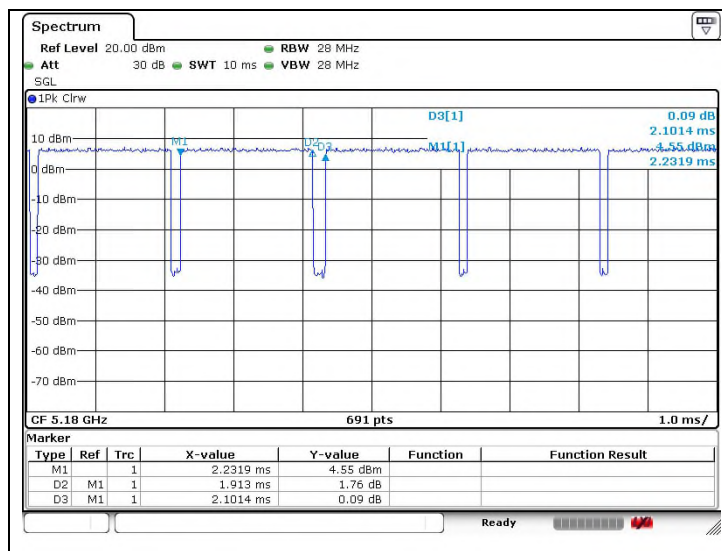

802.11n\_HT40

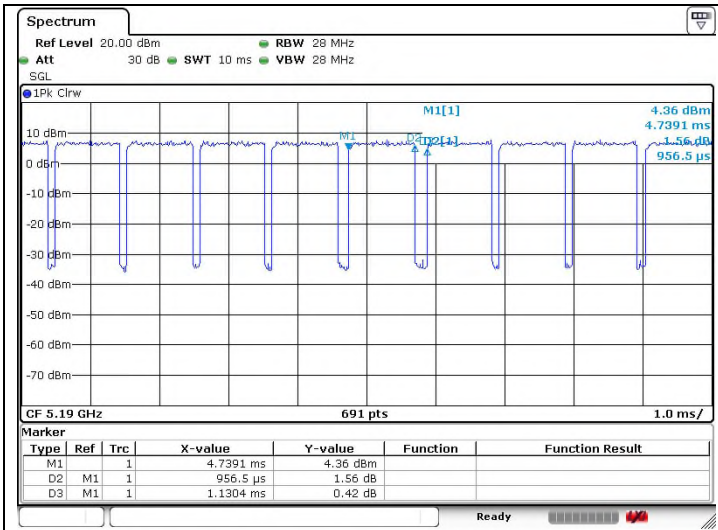

802.11ac\_VHT20

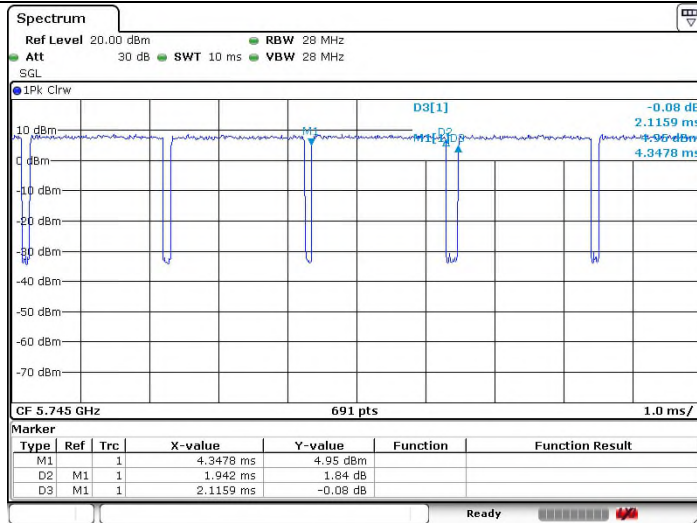

802.11ac\_VHT40

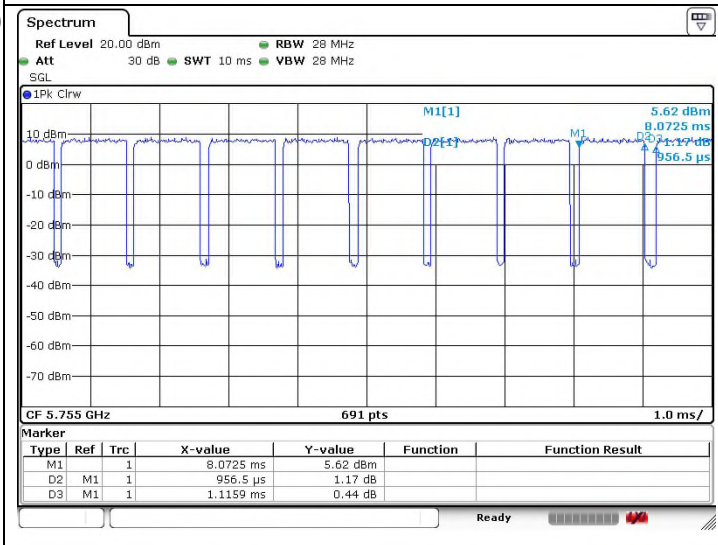



802.11ac\_VHT80

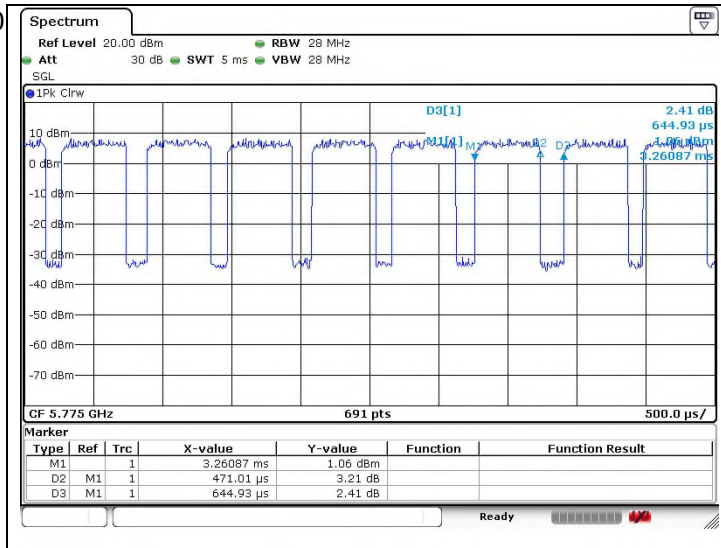

## 2. Transmitter Radiated Spurious Emissions

### 2.1. Test Setup

#### 2.1.1. Transmitter radiated spurious emissions

The diagram below shows the test setup that is utilized to make the measurements for emission from 9 kHz to 30 MHz emissions.

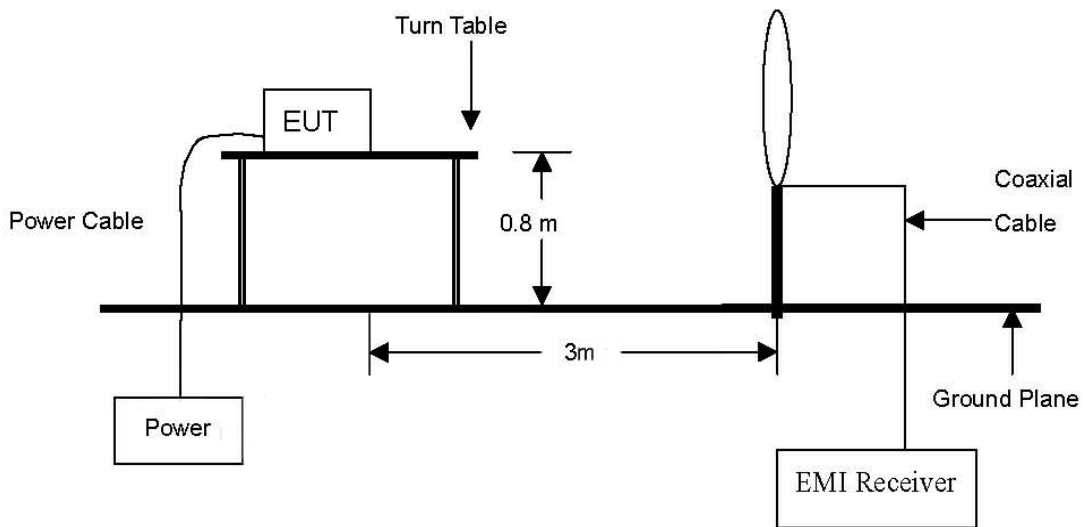

The diagram below shows the test setup that is utilized to make the measurements for emission from 30 MHz to 1 GHz emissions.

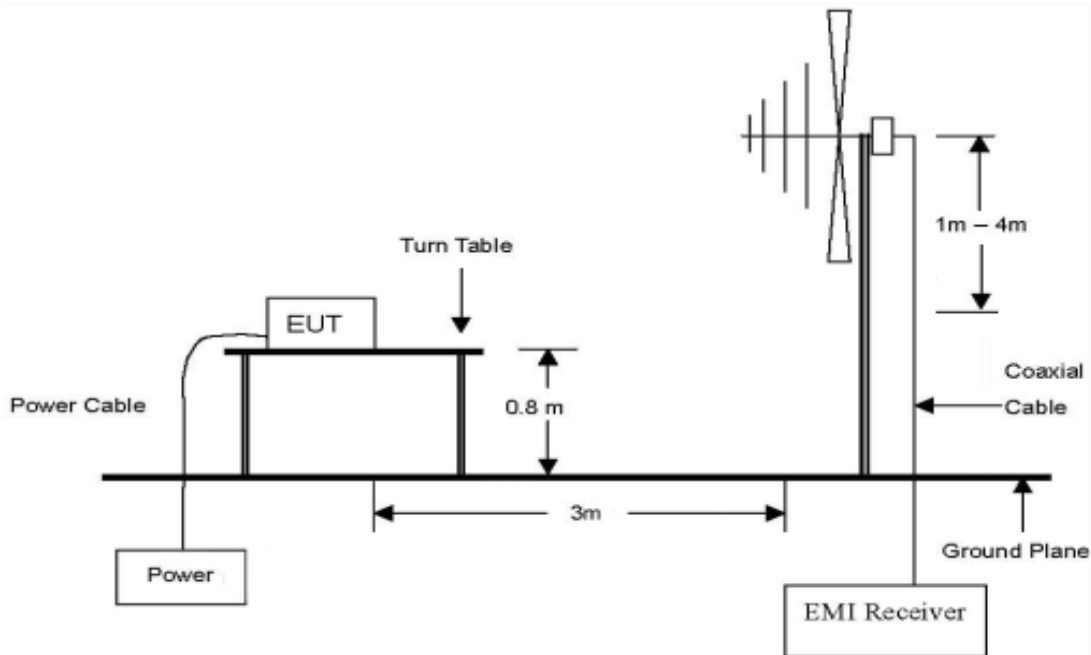

The diagram below shows the test setup that is utilized to make the measurements for emission. The spurious emissions were investigated from 1 GHz to the 10th harmonic of the highest fundamental frequency or 40 GHz, whichever is lower.

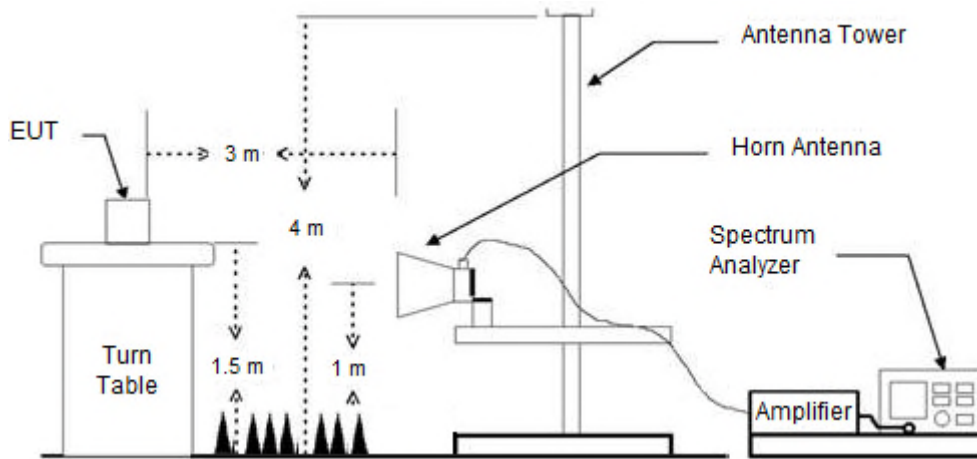

## 2.2. Limit

According to § 15.407(b)

(1) For transmitters operating in the 5.15-5.25 GHz band: All emissions outside of the 5.15-5.35 GHz band shall not exceed an e.i.r.p. of -27 dB m/MHz.

(4) For transmitters operating in the 5.725-5.85 GHz band:

(i) All emissions shall be limited to a level of -27 dB m/MHz at 75 MHz or more above or below the band edge increasing linearly to 10 dB m/MHz at 25 MHz above or below the band edge, and from 25 MHz above or below the band edge increasing linearly to a level of 15.6 dB m/MHz at 5 MHz above or below the band edge, and from 5 MHz above or below the band edge increasing linearly to a level of 27 dB m/MHz at the band edge.

According to § 15.209(a), except as provided elsewhere in this Subpart, the emissions from an intentional radiator shall not exceed the field strength levels specified in the following table:

Frequency (MHz)	Field Strength ( $\mu\text{V}/\text{m}$ )	Measurement Distance (Meters)
0.009-0.490	2 400/F(kHz)	300
0.490-1.705	24 000/F(kHz)	30
1.705-30.0	30	30
30-88	100**	3
88-216	150**	3
216-960	200**	3
Above 960	500	3

\*\* Except as provided in paragraph (g), fundamental emissions from intentional radiators operating under this section shall not be located in the frequency bands 54-72 MHz, 76-88 MHz, 174-216 MHz or 470-806 MHz. However, operation within these frequency bands is permitted under other sections of this part, e.g., §§15.231 and 15.241.

## 2.3. Test Procedures

Radiated spurious emissions from the EUT were measured according to the dictates in section G of KDB 789033 D02 General UNII Test Procedures New Rules v02r01 and ANSI C63.10-2013.

### 2.3.1. Test Procedures for emission below 30 MHz

1. The EUT was placed on the top of a rotating table 0.8 meters above the ground at a 3 meter anechoic chamber test site. The table was rotated 360 degrees to determine the position of the highest radiation.
2. Then antenna is a loop antenna is fixed at one meter above the ground to determine the maximum value of the field strength. Both parallel and perpendicular of the antenna are set to make the measurement.
3. For each suspected emission, the EUT was arranged to its worst case and then the table was turned from 0 degrees to 360 degrees to find the maximum reading.
4. The test-receiver system was set to average or quasi peak detect function and Specified Bandwidth with Maximum Hold Mode.

### 2.3.2. Test Procedures for emission from above 30 MHz

1. The EUT was placed on the top of a rotating table 0.8 meters above the ground at a 3 meter anechoic chamber test site below 1 GHz and 1.5 meter above the ground at a 3 meter anechoic chamber test site above 1 GHz. The table was rotated 360 degrees to determine the position of the highest radiation.
2. During performing radiated emission below 1 GHz, the EUT was set 3 meters away from the interference receiving antenna, which was mounted on the top of a variable-height antenna tower. During performing radiated emission above 1 GHz, the EUT was set 3 meter away from the interference-receiving antenna.
3. The antenna is a bi-log antenna, a horn antenna and its height is varied from one meter to four meters above the ground to determine the maximum value of the field strength. Both horizontal and vertical polarizations of the antenna are set to make the measurement.
4. For each suspected emission, the EUT was arranged to its worst case and then the antenna was tuned to heights from 1 meter to 4 meters and the table was turned from 0 degrees to 360 degrees to find the maximum reading.
5. The test-receiver system was set to Peak Detect Function and Specified Bandwidth with Maximum Hold Mode.

**Note;**

All data rates and modes were investigated for radiated spurious emissions. Only the radiated emissions of the configuration that produced the worst case emissions are reported in this section.

- II.G.4. Unwanted emissions measurements below 1 GHz.

Compliance shall be demonstrated using CISPR quasi-peak detection; however, peak detection is permitted as an alternative to quasi-peak detection.

- II.G.5. Unwanted maximum emissions measurements above 1 GHz.

Peak emission levels are measured by setting the analyzer as follows:

Set to RBW = 1 MHz, VBW ≥ 3 MHz, Detector = Peak, Sweep time = auto, Trace mode= Max hold.

- II.G.6. Average unwanted emissions measurements above 1 GHz.

Set to RBW = 1 MHz, VBW ≥ 3 MHz, Detector = power averaging (rms), Averaging type = power averaging (rms), Sweep time = auto, Perform a trace average of at least 100 traces. If the transmission is continuous, if the transmission is not continuous, the number of traces shall be increased by a factor of 1/x, where x is the duty cycle. For example, with 50 % duty cycle, at least 200 traces shall be averaged.

If tests are performed with the EUT transmitting at a duty cycle less than 98 %, a correction factor shall be added to the measurement results prior to comparing to the emission limit in order to compute the emission level that would have been measured had the test been performed at 100 % duty cycle. The correction factor is computed as follows:

- If power averaging (rms) mode was used in II.G.6.c)(iv), the correction factor is  $10 \log (1/x)$ , where x is the duty cycle. For example, if the transmit duty cycle was 50 %, then 3 dB must be added to the measured emission levels.

- Definition of the test orthogonal plan for EUT was described in the test setup photo.

The test orthogonal plan of EUT is **X – axis** during radiation test.

## 2.4. Test Result

Ambient temperature : (23 ± 1) °C  
 Relative humidity : 47 % R.H.

### 2.4.1. Radiated Spurious Emission below 1 000 MHz

The frequency spectrum from 9 kHz to 1 000 MHz was investigated. All reading values are peak values.

Radiated Emissions			Ant.	Correction Factors		Total	Limit	
Frequency (MHz)	Reading (dBμV)	Detect Mode	Pol.	AF (dB/m)	AMP + CL (dB)	Actual (dBμV/m)	Limit (dBμV/m)	Margin (dB)
590.42	29.10	Peak	V	25.02	-24.46	29.66	46.00	16.34
755.44	30.60	Peak	H	26.79	-23.38	<b>34.01</b>	46.00	11.99
Above 800.00	Not detected	-	-	-	-	-	-	-

#### Remark;

- Spurious emissions for all channels and modes were investigated and almost the same below 1 GHz.
- Reported spurious emissions are in **11ac VHT40 (Band 3) / MCS0 / High channel** as worst case among other modes.
- Radiated spurious emission measurement as below.  
 (Actual = Reading + AF + AMP + CL)
- According to §15.31(o), emission levels are not report much lower than the limits by over 20 dB.

#### - Test plot

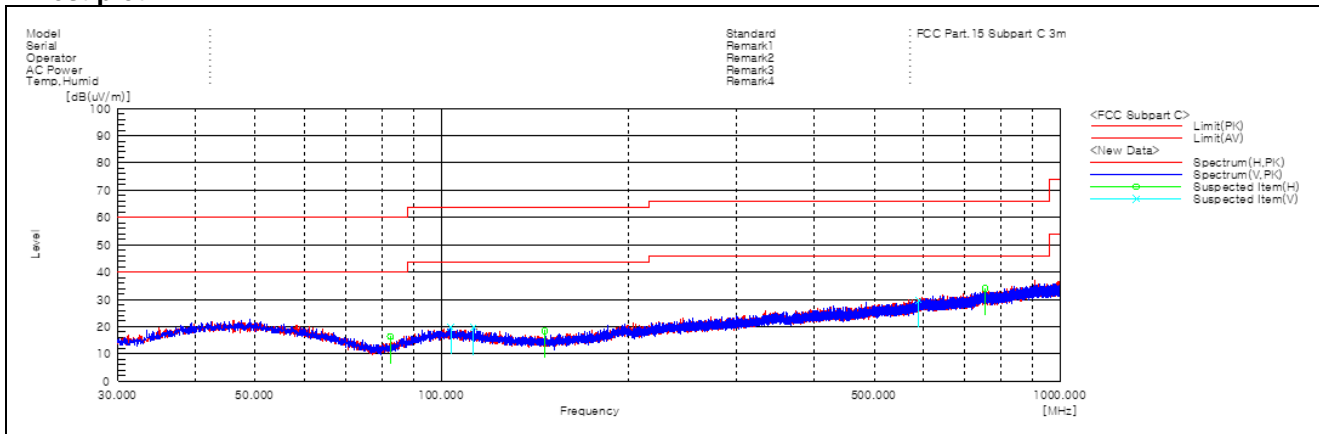

**2.4.2. Radiated Spurious Emission above 1 000 MHz**

**802.11n\_HT20 (Band 1)\_MCS0**

A. Low Channel (5 180 MHz)

Radiated Emissions			Ant.	Correction Factors			Total	Limit	
Frequency (MHz)	Reading (dB $\mu$ V)	Detect Mode	Pol.	AF (dB/m)	AMP+CL (dB)	DF (dB)	Actual (dB $\mu$ V/m)	Limit (dB $\mu$ V/m)	Margin (dB)
*4 500.00	36.75	Peak	H	32.10	-31.15	-	37.70	74.00	36.30
*4 500.00	27.39	Average	H	32.10	-31.15	0.41	28.75	54.00	25.25
*5 148.88	56.56	Peak	H	33.50	-30.01	-	60.05	74.00	13.95
*5 149.59	44.12	Average	H	33.50	-30.01	0.41	48.02	54.00	5.98
*5 150.00	58.15	Peak	H	33.50	-30.01	-	61.64	74.00	12.36
*5 150.00	45.31	Average	H	33.50	-30.01	0.41	<b>49.21</b>	54.00	4.79

Radiated Emissions			Ant.	Correction Factors			Total	Limit	
Frequency (MHz)	Reading (dB $\mu$ V)	Detect Mode	Pol.	AF (dB/m)	AMP+CL (dB)	DF (dB)	Actual (dB $\mu$ V/m)	Limit (dB $\mu$ V/m)	Margin (dB)
Above 1 000.00	Not detected	-	-	-	-	-	-	-	-

B. Middle Channel (5 220 MHz)

Radiated Emissions			Ant.	Correction Factors			Total	Limit	
Frequency (MHz)	Reading (dB $\mu$ V)	Detect Mode	Pol.	AF (dB/m)	AMP+CL (dB)	DF (dB)	Actual (dB $\mu$ V/m)	Limit (dB $\mu$ V/m)	Margin (dB)
Above 1 000.00	Not detected	-	-	-	-	-	-	-	-

C. High Channel (5 240 MHz)

Radiated Emissions			Ant.	Correction Factors			Total	Limit	
Frequency (MHz)	Reading (dB $\mu$ V)	Detect Mode	Pol.	AF (dB/m)	AMP+CL (dB)	DF (dB)	Actual (dB $\mu$ V/m)	Limit (dB $\mu$ V/m)	Margin (dB)
Above 1 000.00	Not detected	-	-	-	-	-	-	-	-



**802.11n\_HT40 (Band 1)\_MCS0**

A. Low Channel (5 190 MHz)

Radiated Emissions			Ant.	Correction Factors			Total	Limit	
Frequency (MHz)	Reading (dB $\mu$ V)	Detect Mode	Pol.	AF (dB/m)	AMP+CL (dB)	DF (dB)	Actual (dB $\mu$ V/m)	Limit (dB $\mu$ V/m)	Margin (dB)
*4 500.00	38.55	Peak	H	32.10	-31.15	-	39.50	74.00	34.50
*4 500.00	28.01	Average	H	32.10	-31.15	0.73	29.69	54.00	24.31
*5 148.88	58.10	Peak	H	33.50	-30.01	-	61.59	74.00	12.41
*5 148.88	45.49	Average	H	33.50	-30.01	0.73	49.71	54.00	4.29
*5 150.00	59.03	Peak	H	33.50	-30.01	-	62.52	74.00	11.48
*5 150.00	46.46	Average	H	33.50	-30.01	0.73	<b>50.68</b>	54.00	3.32

Radiated Emissions			Ant.	Correction Factors			Total	Limit	
Frequency (MHz)	Reading (dB $\mu$ V)	Detect Mode	Pol.	AF (dB/m)	AMP+CL (dB)	DF (dB)	Actual (dB $\mu$ V/m)	Limit (dB $\mu$ V/m)	Margin (dB)
Above 1 000.00	Not detected	-	-	-	-	-	-	-	-

B. High Channel (5 230 MHz)

Radiated Emissions			Ant.	Correction Factors			Total	Limit	
Frequency (MHz)	Reading (dB $\mu$ V)	Detect Mode	Pol.	AF (dB/m)	AMP+CL (dB)	DF (dB)	Actual (dB $\mu$ V/m)	Limit (dB $\mu$ V/m)	Margin (dB)
Above 1 000.00	Not detected	-	-	-	-	-	-	-	-

**802.11ac\_VHT20 (Band 3)\_MCS0**

A. Low Channel (5 745 MHz)

Radiated Emissions			Ant.	Correction Factors			Total	Limit	
Frequency (MHz)	Reading (dB $\mu$ V)	Detect Mode	Pol.	AF (dB/m)	AMP+CL (dB)	DF (dB)	Actual (dB $\mu$ V/m)	Limit (dB $\mu$ V/m)	Margin (dB)
5 638.81	39.79	Peak	H	34.00	-29.00		44.79	68.23	23.44
5 700.00	41.49	Peak	H	34.10	-29.06		46.53	105.23	58.70
5 719.48	48.72	Peak	H	34.06	-29.00		53.78	110.68	56.90
5 724.51	57.43	Peak	H	34.05	-28.99		62.49	121.11	58.62

Radiated Emissions			Ant.	Correction Factors			Total	Limit	
Frequency (MHz)	Reading (dB $\mu$ V)	Detect Mode	Pol.	AF (dB/m)	AMP+CL (dB)	DF (dB)	Actual (dB $\mu$ V/m)	Limit (dB $\mu$ V/m)	Margin (dB)
Above 1 000.00	Not detected	-	-	-	-	-	-	-	-

B. Middle Channel (5 785 MHz)

Radiated Emissions			Ant.	Correction Factors			Total	Limit	
Frequency (MHz)	Reading (dB $\mu$ V)	Detect Mode	Pol.	AF (dB/m)	AMP+CL (dB)	DF (dB)	Actual (dB $\mu$ V/m)	Limit (dB $\mu$ V/m)	Margin (dB)
Above 1 000.00	Not detected	-	-	-	-	-	-	-	-

C. High Channel (5 825 MHz)

Radiated Emissions			Ant.	Correction Factors			Total	Limit	
Frequency (MHz)	Reading (dB $\mu$ V)	Detect Mode	Pol.	AF (dB/m)	AMP+CL (dB)	DF (dB)	Actual (dB $\mu$ V/m)	Limit (dB $\mu$ V/m)	Margin (dB)
5 850.00	47.27	Peak	H	34.30	-29.05		52.52	122.23	69.71
5 858.55	43.64	Peak	H	34.32	-29.03		48.93	109.83	60.90
5 892.59	39.91	Peak	H	34.39	-28.94		45.36	92.21	46.85
5 937.26	39.26	Peak	H	34.55	-28.97		<b>44.84</b>	68.23	23.39

Radiated Emissions			Ant.	Correction Factors			Total	Limit	
Frequency (MHz)	Reading (dB $\mu$ V)	Detect Mode	Pol.	AF (dB/m)	AMP+CL (dB)	DF (dB)	Actual (dB $\mu$ V/m)	Limit (dB $\mu$ V/m)	Margin (dB)
Above 1 000.00	Not detected	-	-	-	-	-	-	-	-

**802.11ac\_VHT40 (Band 3)\_MCS0**

A. Low Channel (5 755 MHz)

Radiated Emissions			Ant.	Correction Factors			Total	Limit	
Frequency (MHz)	Reading (dB $\mu$ V)	Detect Mode	Pol.	AF (dB/m)	AMP+CL (dB)	DF (dB)	Actual (dB $\mu$ V/m)	Limit (dB $\mu$ V/m)	Margin (dB)
5 645.86	40.86	Peak	H	34.00	-28.95		45.91	68.23	22.32
5 699.42	51.35	Peak	H	34.10	-29.06		56.39	104.80	48.41
5 719.03	62.97	Peak	H	34.06	-29.01		68.02	110.56	42.54
5 724.06	65.26	Peak	H	34.05	-28.99		70.32	120.08	49.76

Radiated Emissions			Ant.	Correction Factors			Total	Limit	
Frequency (MHz)	Reading (dB $\mu$ V)	Detect Mode	Pol.	AF (dB/m)	AMP+CL (dB)	DF (dB)	Actual (dB $\mu$ V/m)	Limit (dB $\mu$ V/m)	Margin (dB)
Above 1 000.00	Not detected	-	-	-	-	-	-	-	-

B. High Channel (5 795 MHz)

Radiated Emissions			Ant.	Correction Factors			Total	Limit	
Frequency (MHz)	Reading (dB $\mu$ V)	Detect Mode	Pol.	AF (dB/m)	AMP+CL (dB)	DF (dB)	Actual (dB $\mu$ V/m)	Limit (dB $\mu$ V/m)	Margin (dB)
5 852.14	52.98	Peak	H	34.30	-29.04		58.24	117.35	59.11
5 860.80	50.89	Peak	H	34.32	-29.02		56.19	109.20	53.01
5 880.67	49.12	Peak	H	34.36	-28.97		54.51	101.03	46.52
5 927.36	43.47	Peak	H	34.51	-28.96		49.02	68.23	19.21

Radiated Emissions			Ant.	Correction Factors			Total	Limit	
Frequency (MHz)	Reading (dB $\mu$ V)	Detect Mode	Pol.	AF (dB/m)	AMP+CL (dB)	DF (dB)	Actual (dB $\mu$ V/m)	Limit (dB $\mu$ V/m)	Margin (dB)
Above 1 000.00	Not detected	-	-	-	-	-	-	-	-

**802.11ac\_VHT80 (Band 3)\_MCS0**

A. Middle Channel (5 775 MHz)

Radiated Emissions			Ant.	Correction Factors			Total	Limit	
Frequency (MHz)	Reading (dBμV)	Detect Mode	Pol.	AF (dB/m)	AMP+CL (dB)	DF (dB)	Actual (dBμV/m)	Limit (dBμV/m)	Margin (dB)
5 646.20	40.73	Peak	H	34.00	-28.95		45.78	68.23	22.45
5 695.00	55.58	Peak	H	34.09	-29.05		60.62	101.53	40.91
5 715.80	58.88	Peak	H	34.07	-29.02		63.93	109.65	45.72
5 724.40	60.34	Peak	H	34.05	-28.99		65.40	120.86	55.46
5 853.39	54.44	Peak	H	34.31	-29.04		59.71	114.50	54.79
5 855.00	53.08	Peak	H	34.31	-29.03		58.36	110.83	52.47
5 875.00	44.36	Peak	H	34.35	-28.98		49.73	105.23	55.50
5 989.36	41.15	Peak	H	34.60	-28.85		<b>46.90</b>	68.68	21.78

Radiated Emissions			Ant.	Correction Factors			Total	Limit	
Frequency (MHz)	Reading (dBμV)	Detect Mode	Pol.	AF (dB/m)	AMP+CL (dB)	DF (dB)	Actual (dBμV/m)	Limit (dBμV/m)	Margin (dB)
Above 1 000.00	Not detected	-	-	-	-	-	-	-	-

**Remark;**

1. “\*” means the restricted band.
2. Radiated emissions measured in frequency above 1 000 MHz were made with an instrument using Peak / average detector mode if frequency was in restricted band. Otherwise the frequency was out of restricted band, only peak detector should be used.
3. Actual = Reading + AF + AMP + CL + (DF).
4. If frequency was out of restricted band, the calculation method for peak limit is same as below.  
 $68.23 \text{ dB}\mu\text{V/m} = \text{EIRP} - 20 \log(d) + 104.77 = -27 - 20 \log(3) + 104.77$
5. In case of the emissions within  $\pm 75 \text{ MHz}$  from band edge of band 3, limit should be adjusted to emission mask of 15.407(4)(i).
6. According to § 15.31(o), emission levels are not reported much lower than the limits by over 20 dB.
7. The maximized peak measured value complies with the average limit, to perform an average measurement is unnecessary.

- Test plots

OFDM: 802.11n\_HT20 (MCS0)

Low channel Band edge (Peak) - Band 1

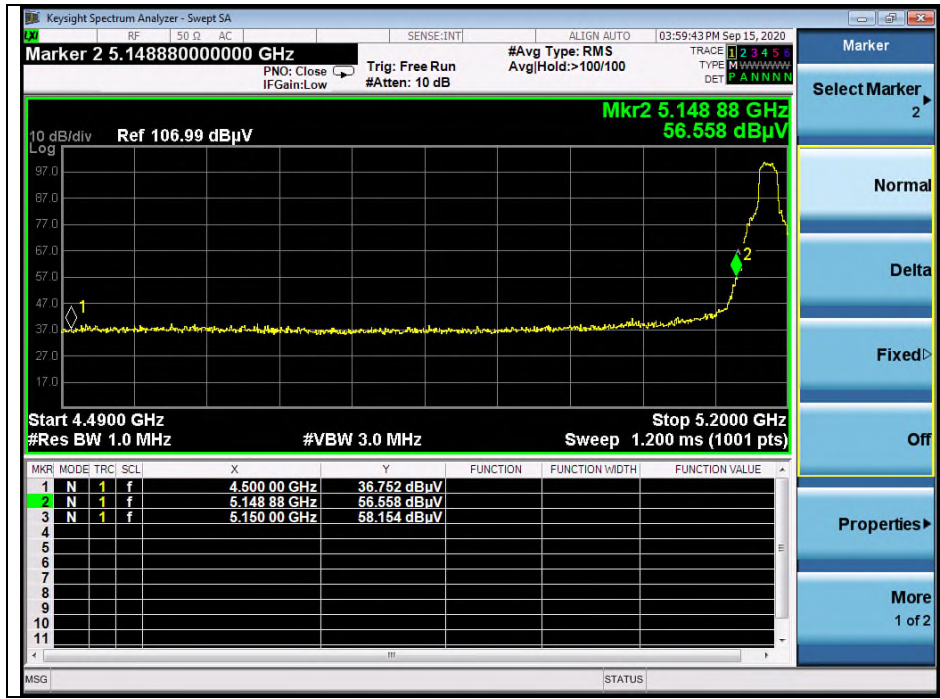

Low channel Band edge (Average) - Band 1

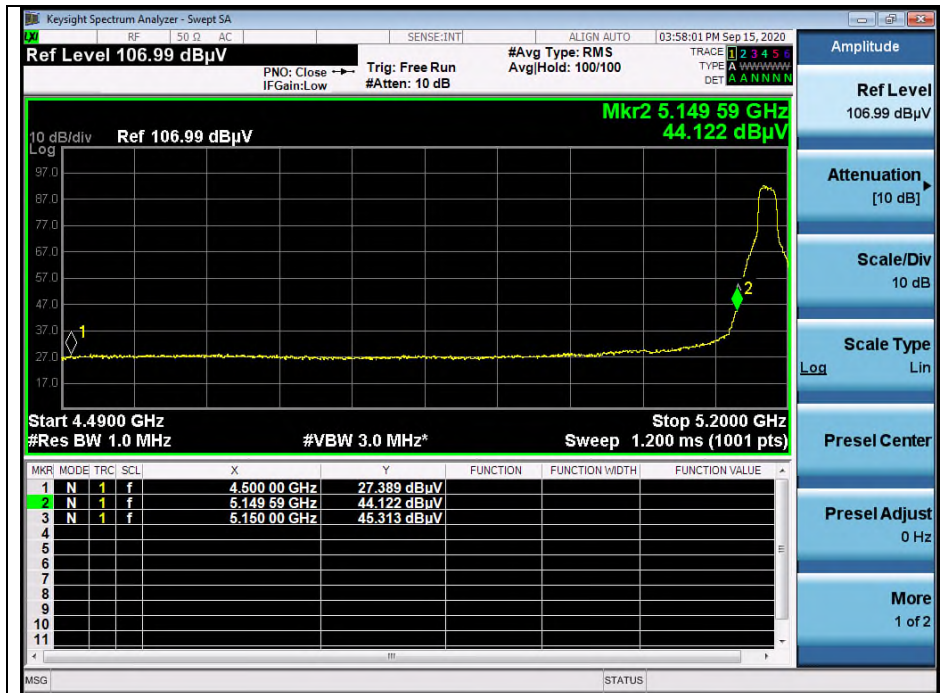

**OFDM: 802.11n\_HT40 (MCS0)**  
 Low channel Band edge (Peak) - Band 1

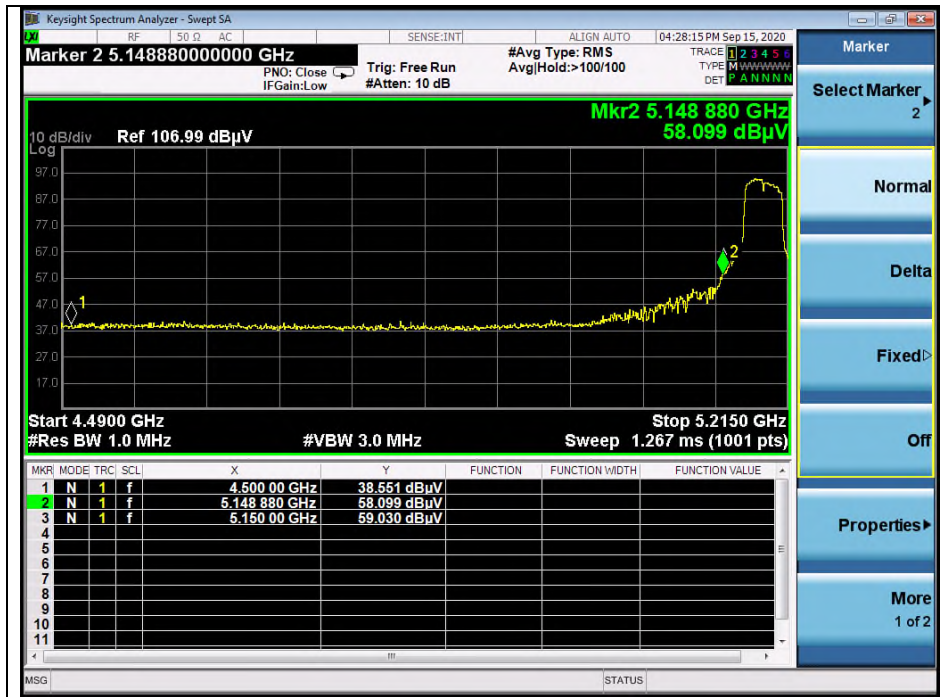

Low channel Band edge (Average) - Band 1

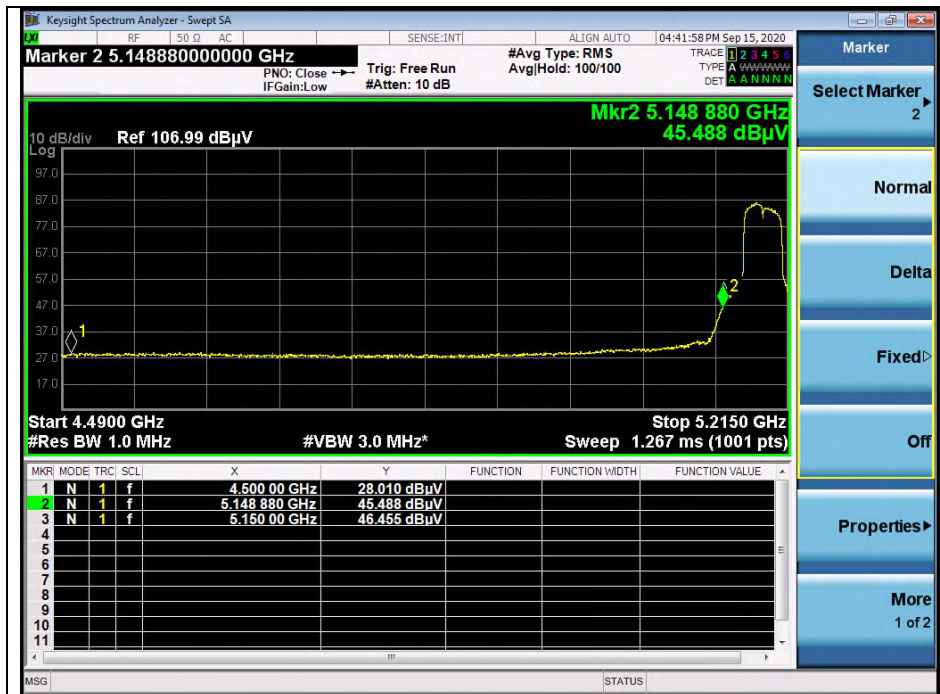



**OFDM: 802.11ac\_VHT20 (MCS0)**

Low channel Band edge (Peak) - Band 3

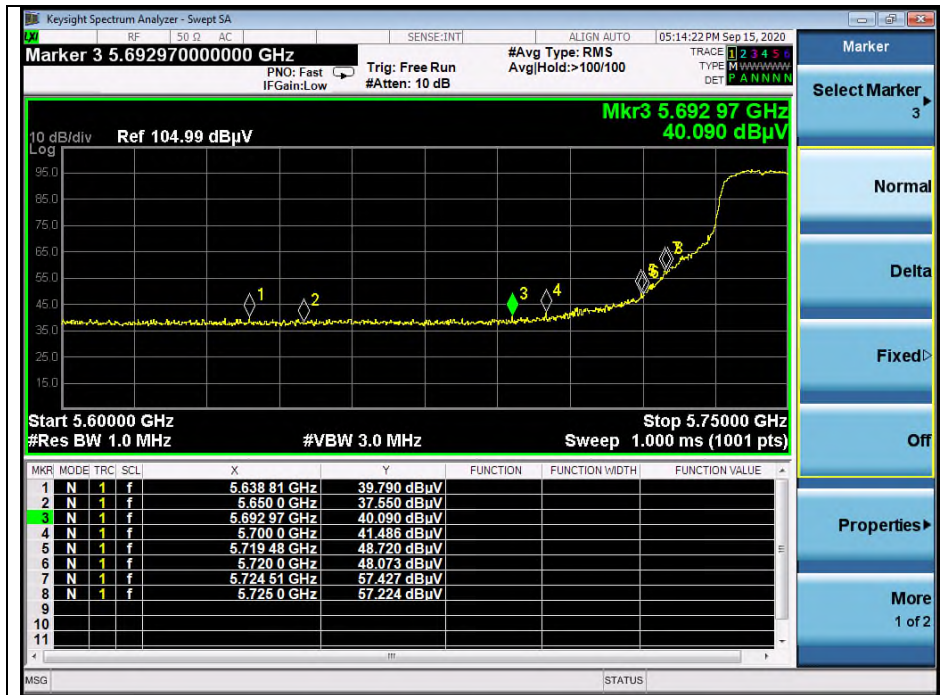

High channel Band edge (Peak) - Band 3



**OFDM: 802.11ac\_VHT40 (MCS0)**

Low channel Band edge (Peak) - Band 3

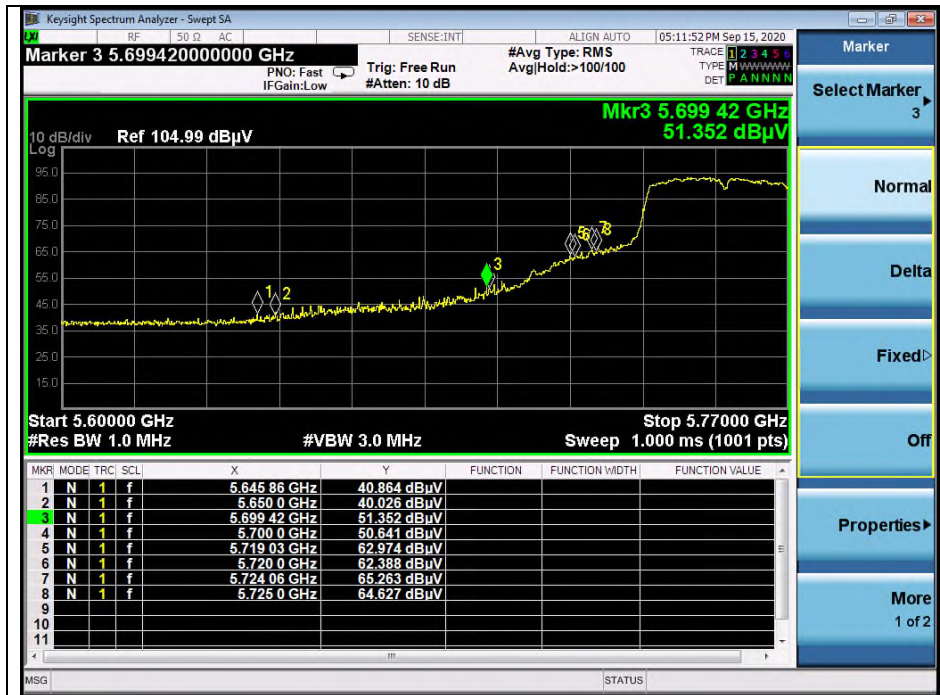

High channel Band edge (Peak) - Band 3





**OFDM: 802.11ac\_VHT80 (MCS0)**

Middle channel Band edge (Peak) - Band 3



Middle channel Band edge (Peak) - Band 3



### 3. 26 dB Bandwidth & 99 % Bandwidth

#### 3.1. Test Setup



#### 3.2. Limit

None; for reporting purpose only.

#### 3.3. Test Procedure

All data rates and modes were investigated for this test. The full data for the worst case data rate are reported in this section.

##### 3.3.1. 26 dB Bandwidth

1. This measurement settings are specified in section II.C.1 of KDB 789033 D02 General UNII Test Procedures New Rules v02r01.
2. Set RBW = approximately 1 % of the emission bandwidth.
3. Set the VBW > RBW.
4. Detector = Peak.
5. Trace mode = max hold.
6. Measure the maximum width of the emission that is 26 dB down from the peak of the emission. Compare this with the RBW setting of the analyzer. Readjust RBW and repeat measurement as needed until the RBW/EBW ratio is approximately 1 %.

### 3.2.2. 99 % Bandwidth

1. This measurement settings are specified in section II.D of KDB 789033 D02 General UNII Test Procedures New Rules v02r01.
2. Set center frequency to the nominal EUT channel center frequency.
3. Set span = 1.5 times to 5.0 times the OBW.
4. Set RBW = 1 % to 5 % of the OBW.
5. Set VBW  $\geq 3 \times$  RBW.
6. Video averaging is not permitted. Where practical, a sample detection and single sweep mode shall be used. Otherwise, peak detection and max hold mode (until the trace stabilizes) shall be used.
7. Use the 99 % power bandwidth function of the instrument (if available).
8. If the instrument does not have a 99 % power bandwidth function, the trace data points are recovered and directly summed in power units. The recovered amplitude data points, beginning at the lowest frequency, are placed in a running sum until 0.5 % of the total is reached; that frequency is recorded as the lower frequency. The process is repeated until 99.5 % of the total is reached; that frequency is recorded as the upper frequency. The 99 % occupied bandwidth is the difference between these two frequencies.

In the result,

- DFS requirements are not applicable in the 5 150 MHz ~ 5 250 MHz.

### 3.4. Test Result

Ambient temperature : (23 ± 1) °C  
 Relative humidity : 47 % R.H.

#### Test mode: 11n\_HT20

Band	Frequency (MHz)	Ch.	Data Rate (Mbps)	26 dB Bandwidth (MHz)	99 % Bandwidth (MHz)
U-NII 1	5 180	36	MCS0	20.145	-
	5 220	44		20.087	-
	5 240	48		20.492	17.424

#### Test mode: 11n\_HT40

Band	Frequency (MHz)	Ch.	Data Rate (Mbps)	26 dB Bandwidth (MHz)	99 % Bandwidth (MHz)
U-NII 1	5 190	38	MCS0	43.068	-
	5 230	46		41.679	36.006

#### Test mode: 11ac\_VHT20

Band	Frequency (MHz)	Ch.	Data Rate (Mbps)	26 dB Bandwidth (MHz)	99 % Bandwidth (MHz)
U-NII 3	5 745	149	MCS0	19.913	-
	5 785	157		20.261	-
	5 825	165		20.145	-

#### Test mode: 11ac\_VHT40

Band	Frequency (MHz)	Ch.	Data Rate (Mbps)	26 dB Bandwidth (MHz)	99 % Bandwidth (MHz)
U-NII 3	5 755	151	MCS0	41.447	-
	5 795	159		41.910	-

#### Test mode: 11ac\_VHT80

Band	Frequency (MHz)	Ch.	Data Rate (Mbps)	26 dB Bandwidth (MHz)	99 % Bandwidth (MHz)
U-NII 3	5 775	155	MCS0	84.515	-

**- Test plots**

**26 dB Bandwidth**

**802.11n\_HT20 (Band 1)**

Low Channel  
(5 180 MHz)

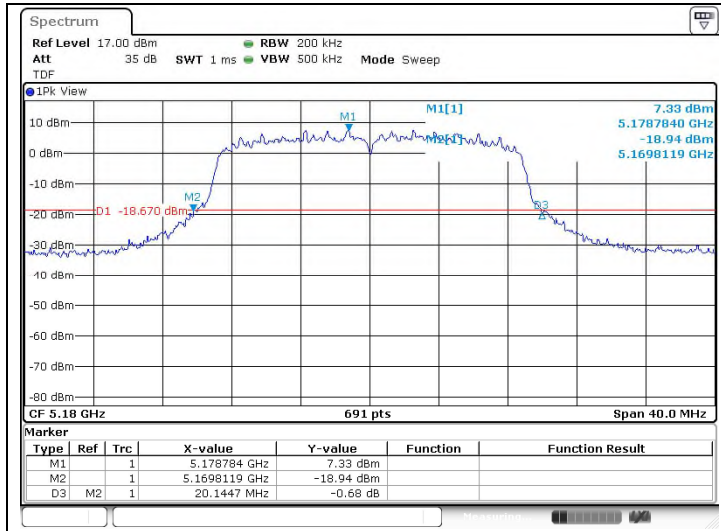

Middle Channel  
(5 220 MHz)

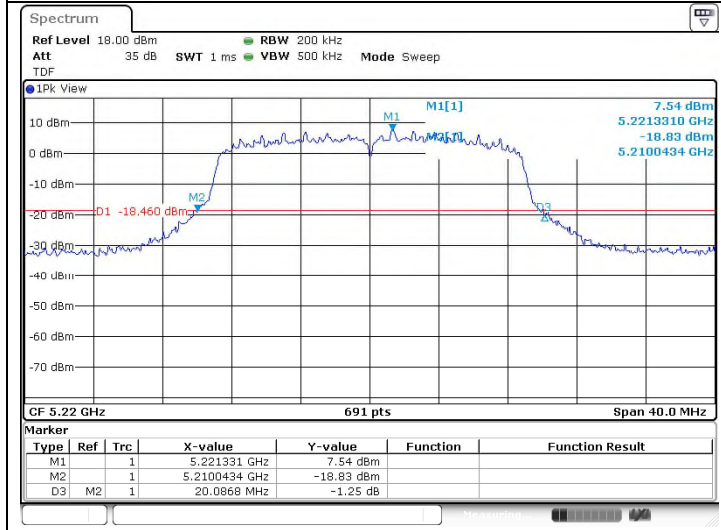

High Channel  
(5 240 MHz)

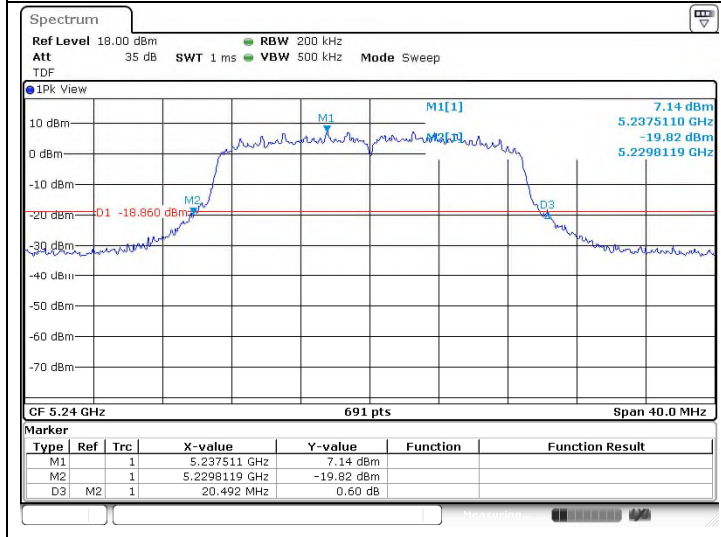

**802.11n\_HT40 (Band 1)**

Low Channel  
(5 190 MHz)

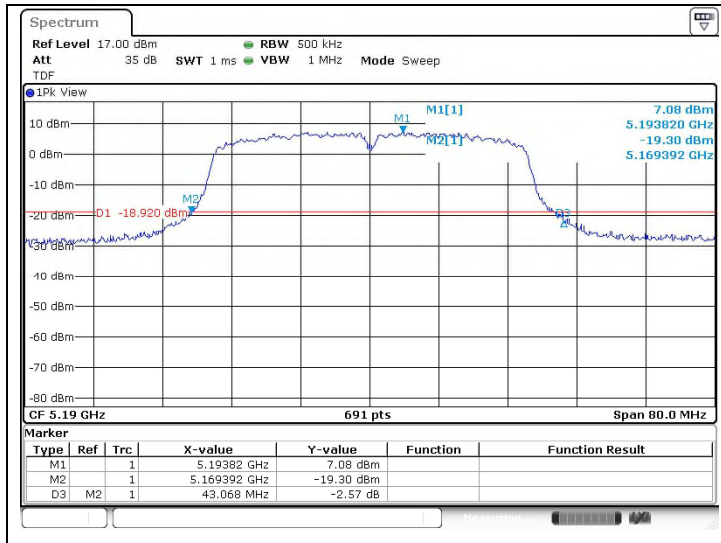

High Channel  
(5 230 MHz)

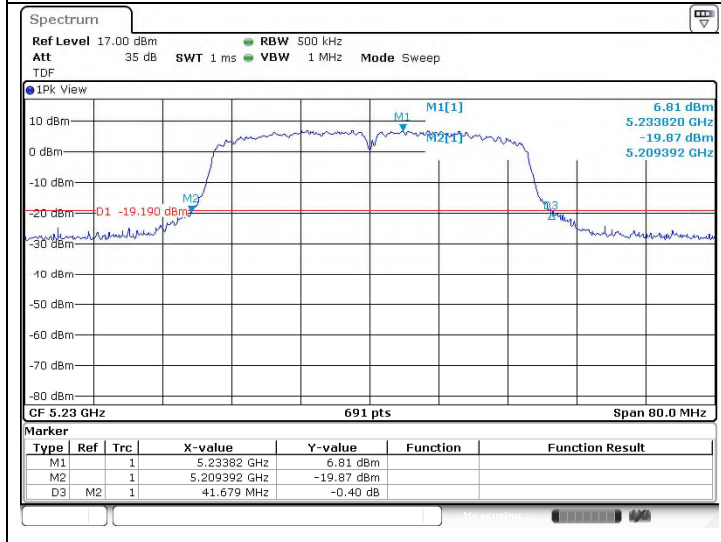

**802.11ac\_VHT20 (Band 3)**

Low Channel  
(5 745 MHz)

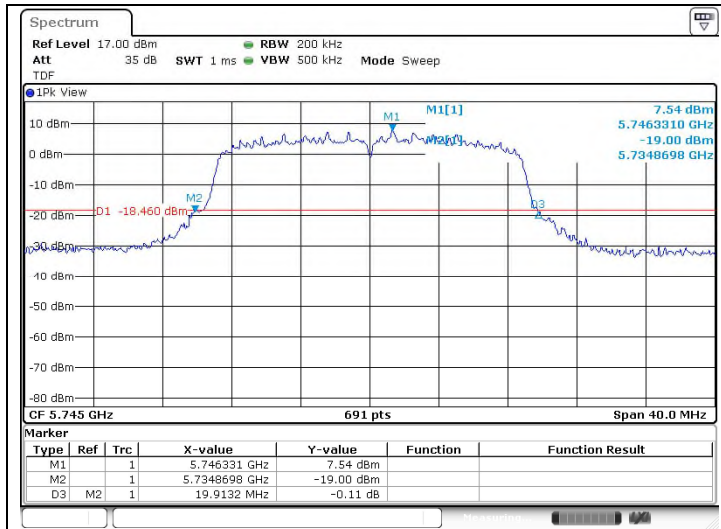

Middle Channel  
(5 785 MHz)

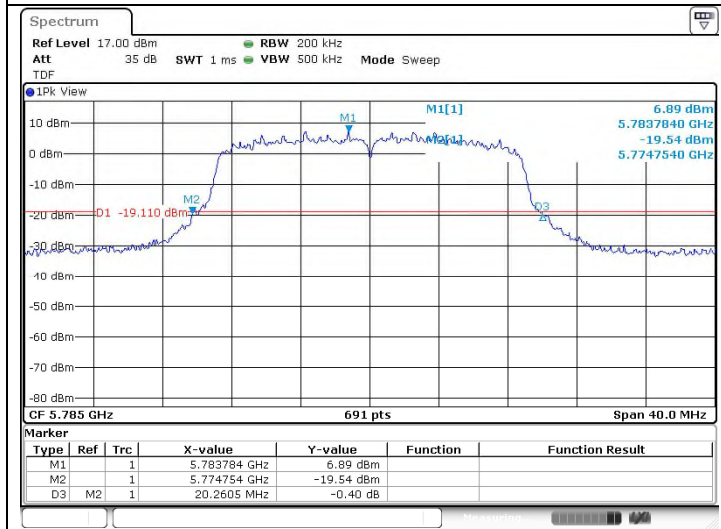

High Channel  
(5 825 MHz)

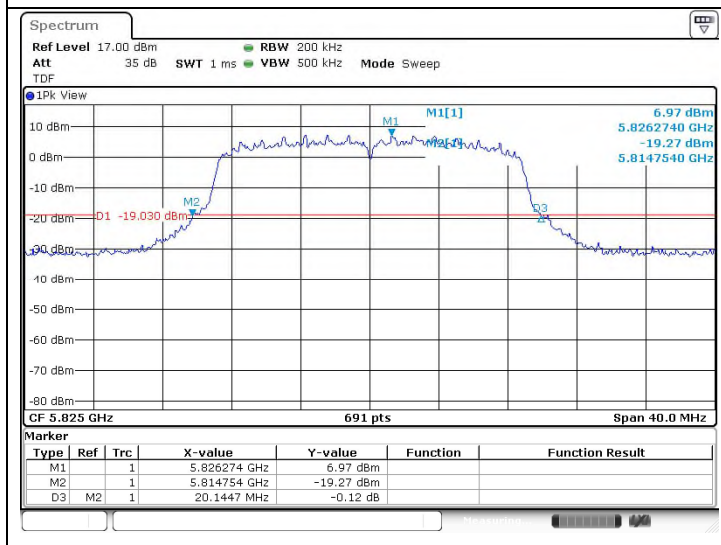



**802.11ac\_VHT40 (Band 3)**

Low Channel  
(5 755 MHz)

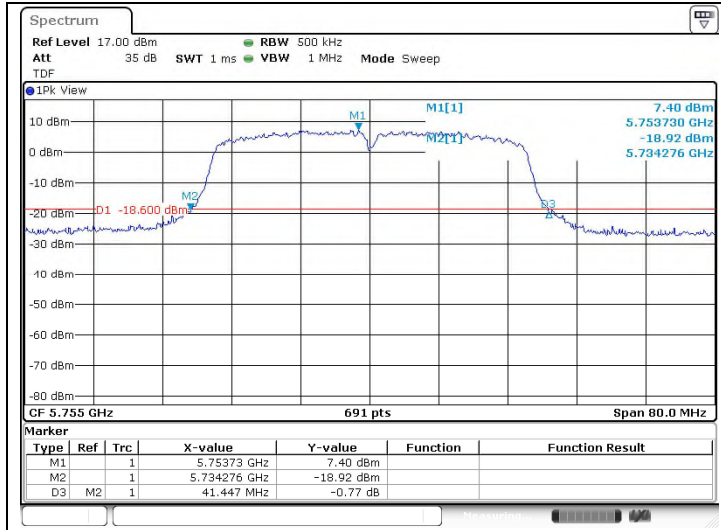

High Channel  
(5 795 MHz)

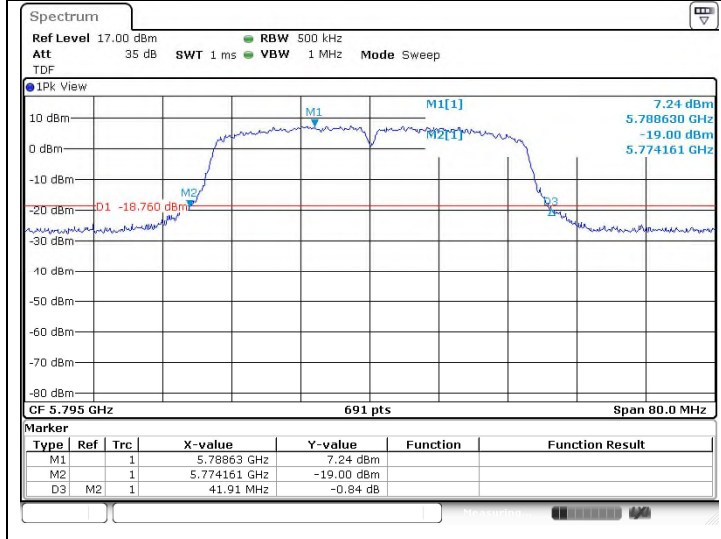



**802. 11ac\_VHT80 (Band 3)**

Middle Channel  
(5.775 MHz)

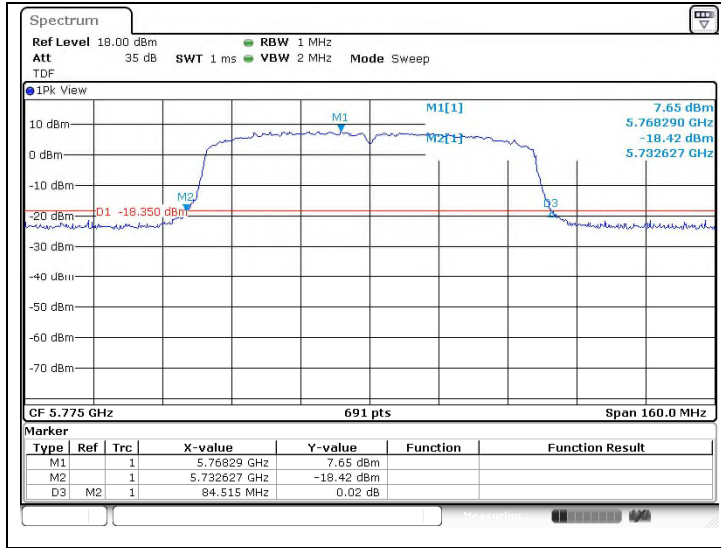

**99 % Bandwidth**

**802.11n\_HT20 (Band 1)**

High Channel  
(5 240 MHz)

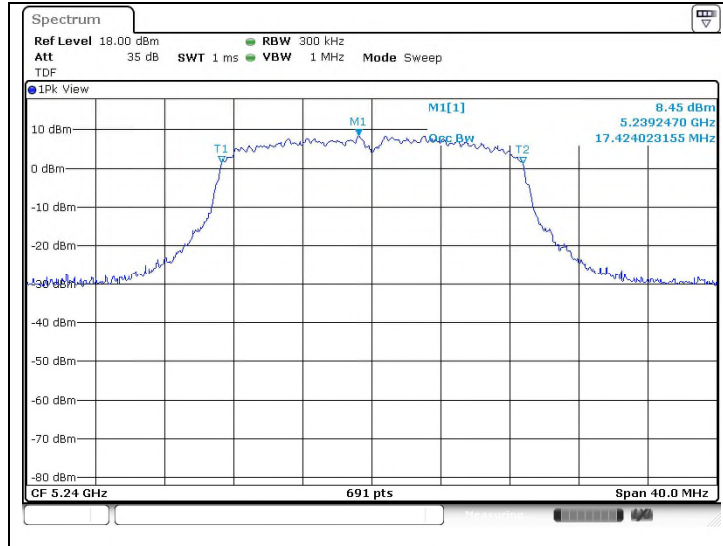

**802.11n\_HT40 (Band 1)**

High Channel  
(5 230 MHz)

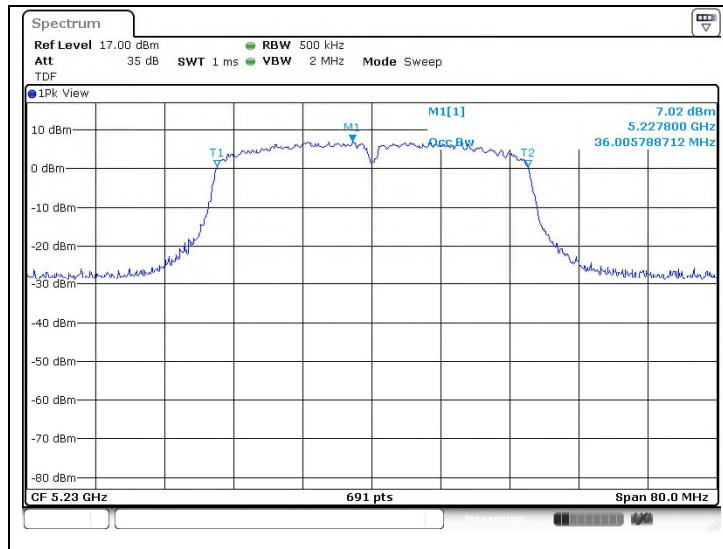

## 4. 6 dB Bandwidth

### 4.1. Test Setup



### 4.2. Limit

According to §15.407(e), within the 5.725-5.85 GHz band, the minimum 6 dB bandwidth of U-NII devices shall be at least 500 kHz.

### 4.3. Test Procedure

All data rates and modes were investigated for this test. The full data for the worst case data rate are reported in this section.

1. This measurement settings are specified in section II.C.2 of KDB 789033 D02 General UNII Test Procedures New Rules v02r01.
2. Set RBW = 100 kHz.
3. Set the video bandwidth (VBW)  $\geq 3 \times$  RBW.
4. Detector = Peak.
5. Trace mode = max hold.
6. Sweep = auto couple.
7. Allow the trace to stabilize.
8. Measure the maximum width of the emission that is constrained by the frequencies associated with the two outermost amplitude points (upper and lower frequencies) that are attenuated by 6 dB relative to the maximum level measured in the fundamental emission.

#### 4.4. Test Result

Ambient temperature : (23 ± 1) °C

Relative humidity : 47 % R.H.

Band	Mode	Frequency (MHz)	Ch.	Data Rate (Mbps)	6 dB Bandwidth (MHz)	Minimum Bandwidth (kHz)
U-NII 3	11ac_VHT20	5 745	149	MCS0	15.282	500
		5 785	157		15.224	
		5 825	165		15.224	
	11ac_VHT40	5 755	151	MCS0	35.311	
		5 795	159		35.311	
		11ac_VHT80	5 775		155	

**- Test plots**

**802.11ac\_VHT20 (Band 3)**

Low Channel  
(5 745 MHz)

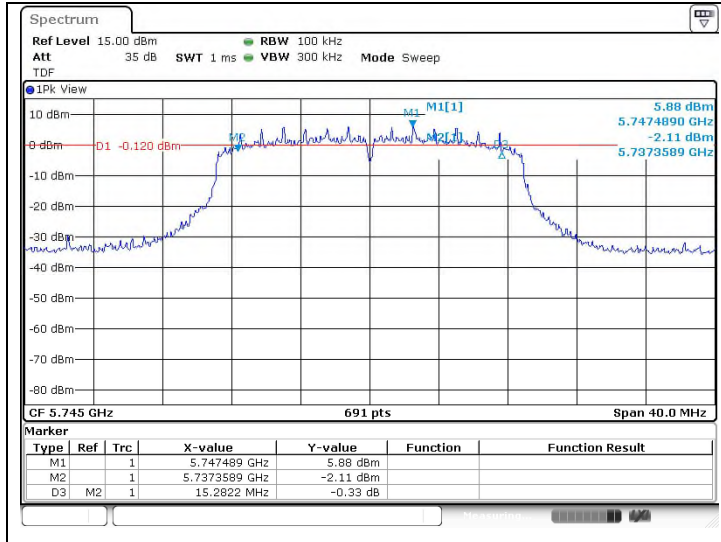

Middle Channel  
(5 785 MHz)

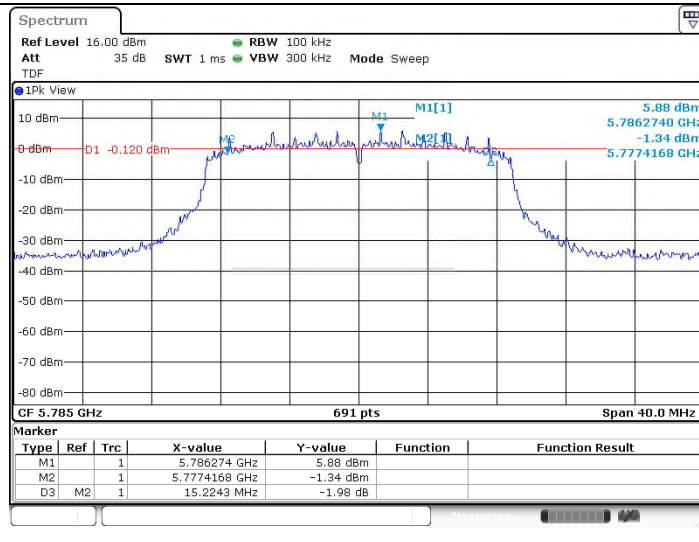

High Channel  
(5 825 MHz)

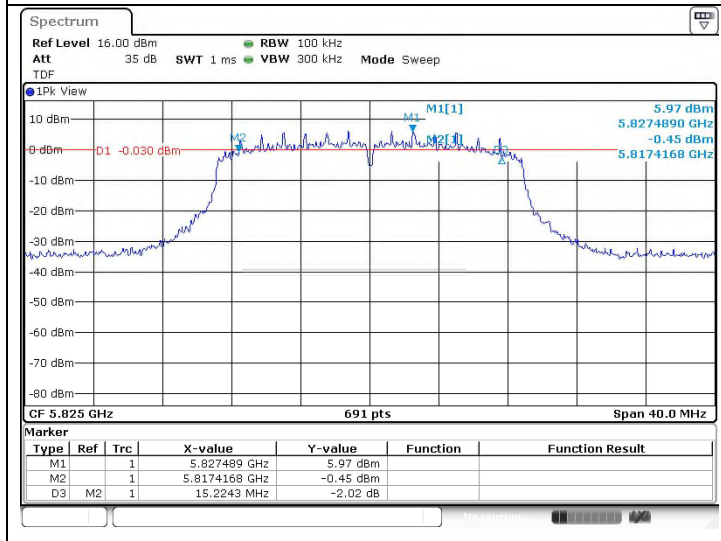

**802.11ac\_VHT40 (Band 3)**

Low Channel  
(5 755 MHz)

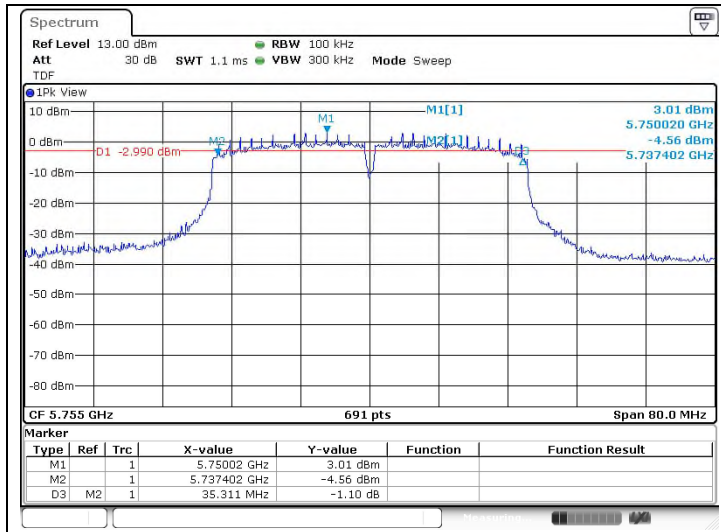

High Channel  
(5 795 MHz)

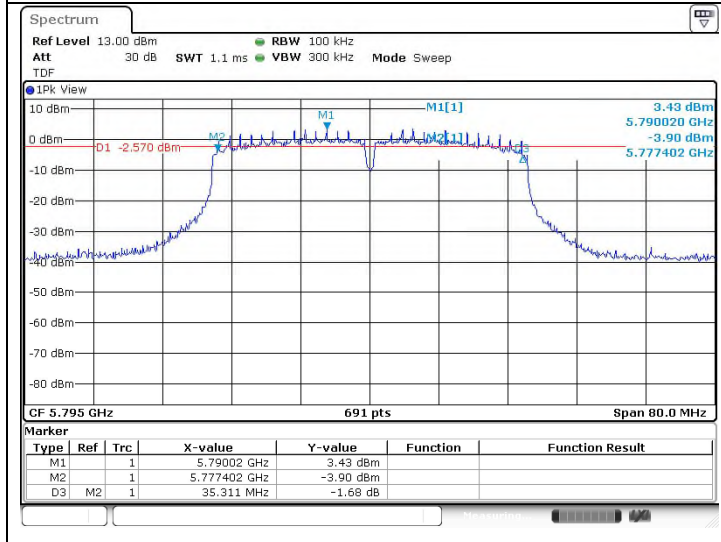

**802.11ac\_VHT80 (Band 3)**

Middle Channel  
(5 775 MHz)

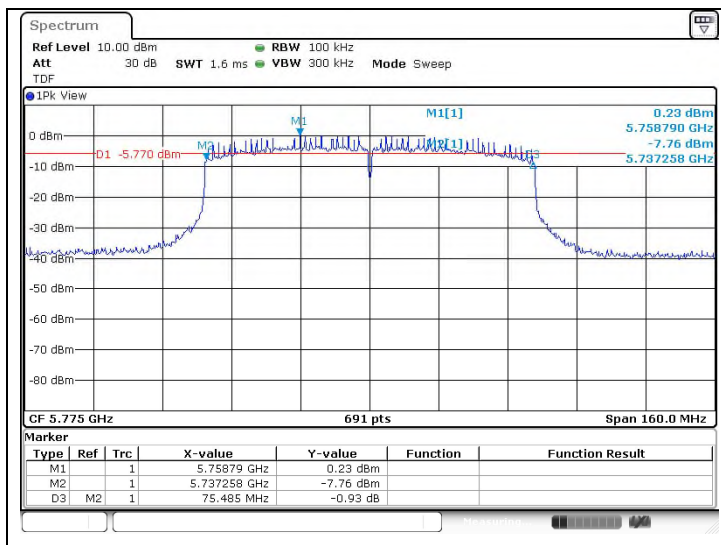

## 5. Maximum Conducted Output Power

### 5.1. Test Setup

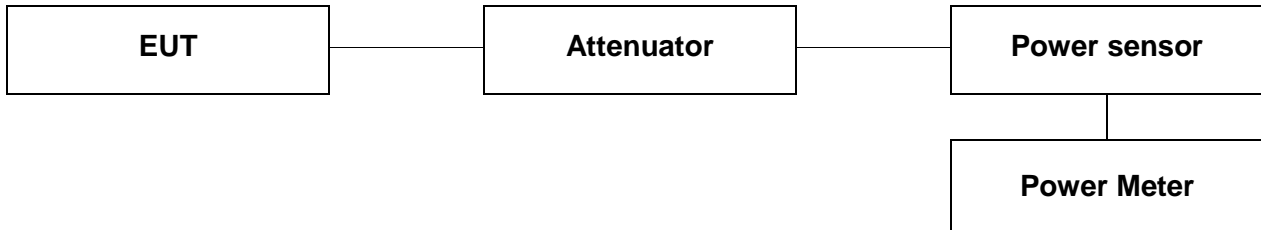

### 5.2. Limit

According to 15.407(a)(1)(iv)

For client devices in the 5.15-5.25 GHz band, the maximum conducted output power over the frequency band of operation shall not exceed 250 mW provided the maximum antenna gain does not exceed 6 dB i. In addition, the maximum power spectral density shall not exceed 11 dB m in any 1 megahertz band. If transmitting antennas of directional gain greater than 6 dB i are used, both the maximum conducted output power and the maximum power spectral density shall be reduced by the amount in dB that the directional gain of the antenna exceeds 6 dB i.

According to 15.407(a)(3)

For the band 5.725-5.85 GHz, the maximum conducted output power over the frequency band of operation shall not exceed 1 W. In addition, the maximum power spectral density shall not exceed 30 dB m in any 500-kHz band. If transmitting antennas of directional gain greater than 6 dB i are used, both the maximum conducted output power and the maximum power spectral density shall be reduced by the amount in dB that the directional gain of the antenna exceeds 6 dB i. However, fixed point-to point U-NII devices operating in this band may employ transmitting antennas with directional gain greater than 6 dB i without any corresponding reduction in transmitter conducted power. Fixed, point-to-point operations exclude the use of point-to-multipoint systems, omnidirectional applications, and multiple collocated transmitters transmitting the same information. The operator of the U-NII device, or if the equipment is professionally installed, the installer, is responsible for ensuring that systems employing high gain directional antennas are used exclusively for fixed, point-to-point operations.

### 5.3. Test Procedure

All data rates and modes were investigated for this test. The full data for the worst case data rate are reported in this section.

1. This measurement settings are specified in section II.E.3.a of KDB 789033 D02 General UNII Test Procedures New Rules v02r01.
2. Measurements may be performed using a wideband RF power meter with a thermocouple detector or equivalent if all of the conditions listed below are satisfied:
  - The EUT is configured to transmit continuously or to transmit with a consistent duty cycle.
  - At all times when the EUT is transmitting, it must be transmitting at its maximum power control level.
  - The integration period of the power meter exceeds the repetition period of the transmitted signal by at least a factor of five.
3. If the transmitter does not transmit continuously, measure the duty cycle,  $x$ , of the transmitter output signal as described in section II.B.
4. Measure the average power of the transmitter. This measurement is an average over both the on and off periods of the transmitter.
5. Adjust the measurement in dBm by adding  $10 \log (1 / x)$  where  $x$  is the duty cycle (e.g.,  $10 \log (1 / 0.25)$  if the duty cycle is 25 %).



### 5.4. Test Result

Ambient temperature : (23 ± 1) °C  
 Relative humidity : 47 % R.H.

#### Test mode: 11n\_HT20

Band	Frequency (MHz)	Data Rate (Mbps)	Average Power (dB m)	Duty Cycle Correction Factor (dB)	Average Power Result (dB m)
U-NII 1	5 180	MCS0	16.85	0.41	17.26
	5 220		16.52		16.93
	5 240		16.41		16.82

Band	Frequency (MHz)	Limit				Limit (dB m)
		Fixed Limit (dB m)	26 dB BW (MHz)	11+10LogB (dB m)	Antenna Gain (dB i)	
U-NII 1	5 180	23.98	/		4.69	23.98
	5 220					
	5 240					

#### Test mode: 11n\_HT40

Band	Frequency (MHz)	Data Rate (Mbps)	Average Power (dB m)	Duty Cycle Correction Factor (dB)	Average Power Result (dB m)
U-NII 1	5 190	MCS0	12.83	0.73	13.56
	5 230		12.43		13.16

Band	Frequency (MHz)	Limit				Limit (dB m)
		Fixed Limit (dB m)	26 dB BW (MHz)	11+10LogB (dB m)	Antenna Gain (dB i)	
U-NII 1	5 190	23.98	/		4.69	23.98
	5 230					

**Test mode: 11ac\_VHT20**

Band	Frequency (MHz)	Data Rate (Mbps)	Average Power (dB m)	Duty Cycle Correction Factor (dB)	Average Power Result (dB m)
U-NII 3	5 745	MCS0	16.87	0.37	17.24
	5 785		16.81		17.18
	5 825		16.87		17.24

Band	Limit					
	Frequency (MHz)	Fixed Limit (dB m)	26 dB BW (MHz)	11+10LogB (dB m)	Antenna Gain (dB i)	Limit (dB m)
U-NII 3	5 745	30			3.00	30
	5 785					
	5 825					

**Test mode: 11ac\_VHT40**

Band	Frequency (MHz)	Data Rate (Mbps)	Average Power (dB m)	Duty Cycle Correction Factor (dB)	Average Power Result (dB m)
U-NII 3	5 755	MCS0	16.62	0.67	17.29
	5 795		16.80		17.47

Band	Limit					
	Frequency (MHz)	Fixed Limit (dB m)	26 dB BW (MHz)	11+10LogB (dB m)	Antenna Gain (dB i)	Limit (dB m)
U-NII 3	5 755	30			3.00	30
	5 795					

**Test mode: 11ac\_VHT80**

Band	Frequency (MHz)	Data Rate (Mbps)	Average Power (dB m)	Duty Cycle Correction Factor (dB)	Average Power Result (dB m)
U-NII 3	5 775	MCS0	15.59	1.36	16.95

Band	Limit					
	Frequency (MHz)	Fixed Limit (dB m)	26 dB BW (MHz)	11+10LogB (dB m)	Antenna Gain (dB i)	Limit (dB m)
U-NII 3	5 775	30			3.00	30

**Remark;**

1. Average Power Result (dB m) = Average Power (dB m) + Duty Cycle Correction Factor (dB)

## 6. Peak Power Spectral Density

### 6.1. Test Setup



### 6.2. Limit

According to 15.407(a)(1)(iv)

For client devices in the 5.15-5.25 GHz band, the maximum conducted output power over the frequency band of operation shall not exceed 250 mW provided the maximum antenna gain does not exceed 6 dB i. In addition, the maximum power spectral density shall not exceed 11 dB m in any 1 megahertz band. If transmitting antennas of directional gain greater than 6 dB i are used, both the maximum conducted output power and the maximum power spectral density shall be reduced by the amount in dB that the directional gain of the antenna exceeds 6 dB i.

According to 15.407(a)(3)

For the band 5.725-5.85 GHz, the maximum conducted output power over the frequency band of operation shall not exceed 1 W. In addition, the maximum power spectral density shall not exceed 30 dB m in any 500-kHz band. If transmitting antennas of directional gain greater than 6 dB i are used, both the maximum conducted output power and the maximum power spectral density shall be reduced by the amount in dB that the directional gain of the antenna exceeds 6 dB i. However, fixed point-to-point U-NII devices operating in this band may employ transmitting antennas with directional gain greater than 6 dB i without any corresponding reduction in transmitter conducted power. Fixed, point-to-point operations exclude the use of point-to-multipoint systems, omnidirectional applications, and multiple collocated transmitters transmitting the same information. The operator of the U-NII device, or if the equipment is professionally installed, the installer, is responsible for ensuring that systems employing high gain directional antennas are used exclusively for fixed, point-to-point operations.

### 6.3. Test Procedure

All data rates and modes were investigated for this test. The full data for the worst case data rate are reported in this section.

1. This measurement settings are specified in section II.F of KDB 789033 D02 General UNII Test Procedures New Rules v02r01.
2. Create an average power spectrum for the EUT operating mode being tested by following the instructions in section II.E.2. for measuring maximum conducted output power using a spectrum analyzer or EMI receiver: select the appropriate test method (SA-1, SA-2, SA-3, or alternatives to each) and apply it up to, but not including, the step labeled, "Compute power...". (This procedure is required even if the maximum conducted output power measurement was performed using a power meter, method PM.)
3. Use the peak search function on the instrument to find the peak of the spectrum and record its value.
4. Make the following adjustments to the peak value of the spectrum, if applicable:
  - a) **If Method SA-2 or SA-2 Alternative was used, add  $10\log(1/x)$ , where  $x$  is the duty cycle, to the peak of the spectrum.**
  - b) If Method SA-3 Alternative was used and the linear mode was used in step II.E.2.g)(viii), add 1 dB to the final result to compensate for the difference between linear averaging and power averaging.
5. The result is the Maximum PSD over 1 MHz reference bandwidth.
6. For devices operating in the bands 5.15-5.25 GHz, 5.25-5.35 GHz, and 5.47-5.725 GHz, the above procedures make use of 1 MHz RBW to satisfy directly the 1 MHz reference bandwidth specified in § 15.407(a)(5). For devices operating in the band 5.725-5.85 GHz, the rules specify a measurement bandwidth of 500 kHz. Many spectrum analyzers do not have 500 kHz RBW, thus a narrower RBW may need to be used. The rules permit the use of a RBWs less than 1 MHz, or 500 kHz, "provided that the measured power is integrated over the full reference bandwidth" to show the total power over the specified measurement bandwidth (*i.e.*, 1 MHz, or 500 kHz). If measurements are performed using a reduced resolution bandwidth ( $< 1$  MHz, or  $< 500$  kHz) and integrated over 1 MHz, or 500 kHz bandwidth, the following adjustments to the procedures apply:
  - a) Set  $RBW \geq 1/T$ , where  $T$  is defined in section II.B.1.a).
  - b) Set  $VBW \geq 3$  RBW.
  - c) If measurement bandwidth of Maximum PSD is specified in 500 kHz, add  $10\log(500 \text{ kHz} / RBW)$  to the measured result, whereas RBW ( $< 500$  kHz) is the reduced resolution bandwidth of the spectrum analyzer set during measurement.
  - d) If measurement bandwidth of Maximum PSD is specified in 1 MHz, add  $10\log(1 \text{ MHz} / RBW)$  to the measured result, whereas RBW ( $< 1$  MHz) is the reduced resolution bandwidth of spectrum analyzer set during measurement.
  - e) Care must be taken to ensure that the measurements are performed during a period of continuous transmission or are corrected upward for duty cycle.

### 6.4. Test Result

Ambient temperature : (23 ± 1) °C  
 Relative humidity : 47 % R.H.

#### Test mode: 11n\_HT20

Band	Frequency (MHz)	Ch.	Data Rate (Mbps)	Measured PPSD (dB m)	Duty Cycle Correction Factor (dB)	Final PPSD (dB m)	Limit (dB m/1 MHz)
U-NII 1	5 180	36	MCS0	5.65	0.41	6.06	11
	5 220	44		5.46		5.87	
	5 240	48		5.19		5.60	

#### Test mode: 11n\_HT40

Band	Frequency (MHz)	Ch.	Data Rate (Mbps)	Measured PPSD (dB m)	Duty Cycle Correction Factor (dB)	Final PPSD (dB m)	Limit (dB m/1 MHz)
U-NII 1	5 190	38	MCS0	-1.50	0.73	-0.77	11
	5 230	46		-1.52		-0.79	

#### Test mode: 11ac\_VHT20

Band	Frequency (MHz)	Ch.	Data Rate (Mbps)	Measured PPSD (dB m)	Duty Cycle Correction Factor (dB)	Final PPSD (dB m)	Limit (dB m/500 kHz)
U-NII 3	5 745	149	MCS0	2.74	0.37	3.11	30
	5 785	157		2.54		2.91	
	5 825	165		2.51		2.88	

#### Test mode: 11ac\_VHT40

Band	Frequency (MHz)	Ch.	Data Rate (Mbps)	Measured PPSD (dB m)	Duty Cycle Correction Factor (dB)	Final PPSD (dB m)	Limit (dB m/500 kHz)
U-NII 3	5 755	151	MCS0	-1.00	0.67	-0.33	30
	5 795	159		-0.62		0.05	

#### Test mode: 11ac\_VHT80

Band	Frequency (MHz)	Ch.	Data Rate (Mbps)	Measured PPSD (dB m)	Duty Cycle Correction Factor (dB)	Final PPSD (dB m)	Limit (dB m/500 kHz)
U-NII 3	5 775	155	MCS0	-4.52	1.36	-3.16	30

#### Remark;

- Final PPSD (dB m) = Measured PPSD (dB m) + Duty Cycle Correction Factor (dB)

**- Test plots**

**802.11n\_HT20 (Band 1)**

Low Channel  
(5 180 MHz)



Middle Channel  
(5 220 MHz)

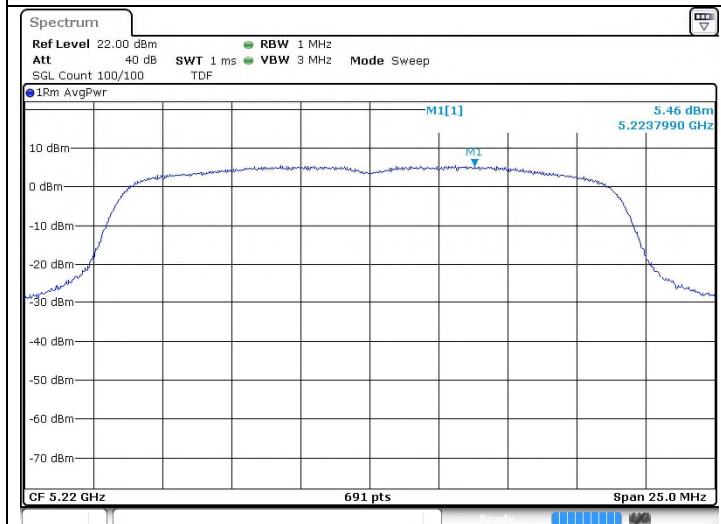

High Channel  
(5 240 MHz)

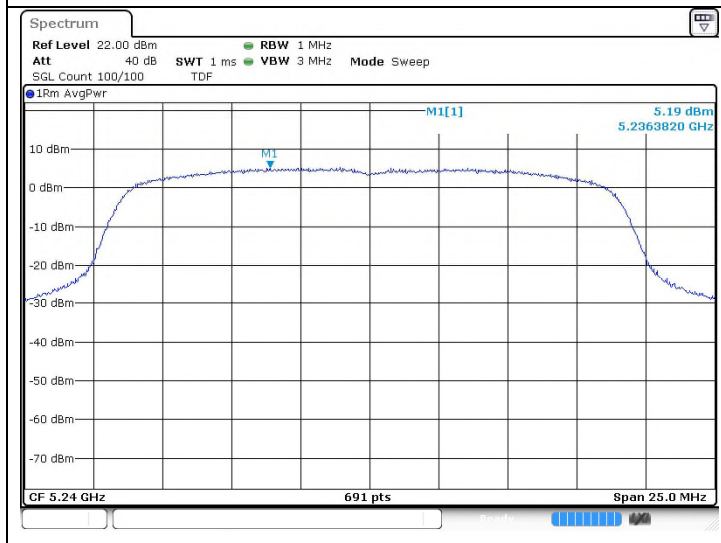

**802.11n\_HT40 (Band 1)**

Low Channel  
(5 190 MHz)

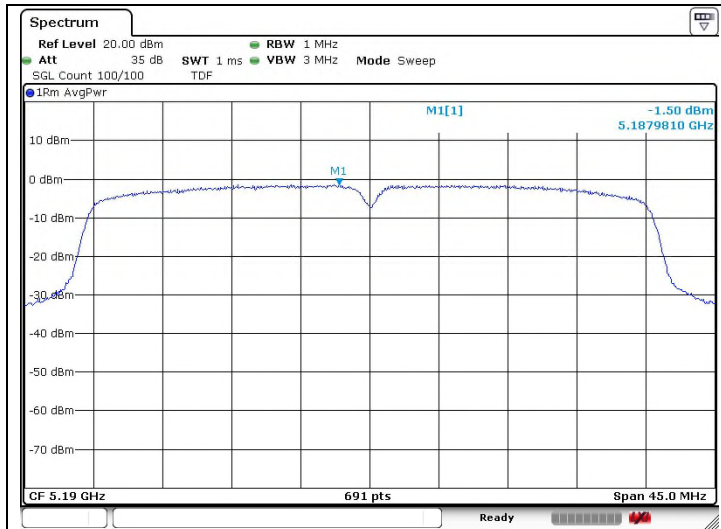

High Channel  
(5 230 MHz)

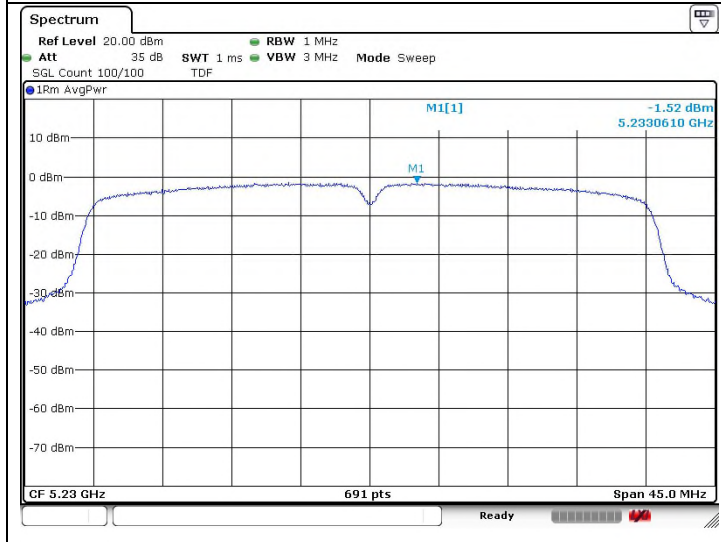

**802.11ac\_VHT20 (Band 3)**

Low Channel  
(5 745 MHz)

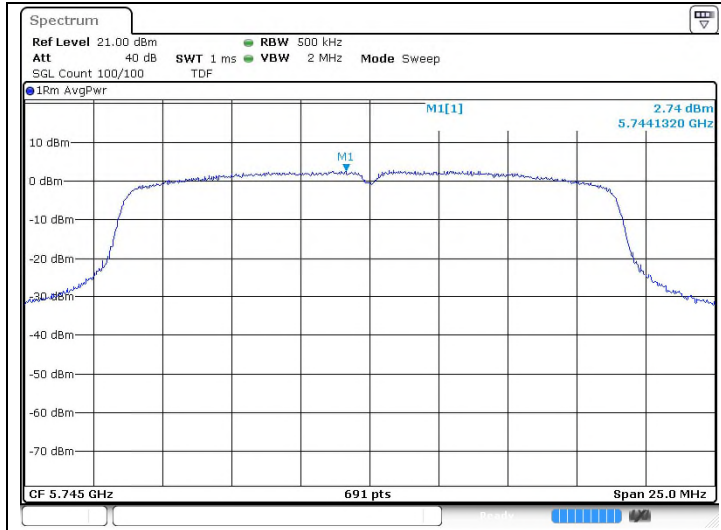

Middle Channel  
(5 785 MHz)

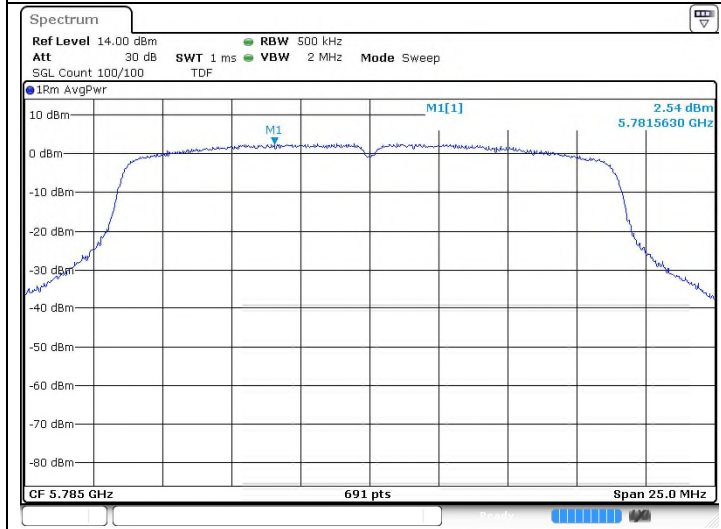

High Channel  
(5 825 MHz)

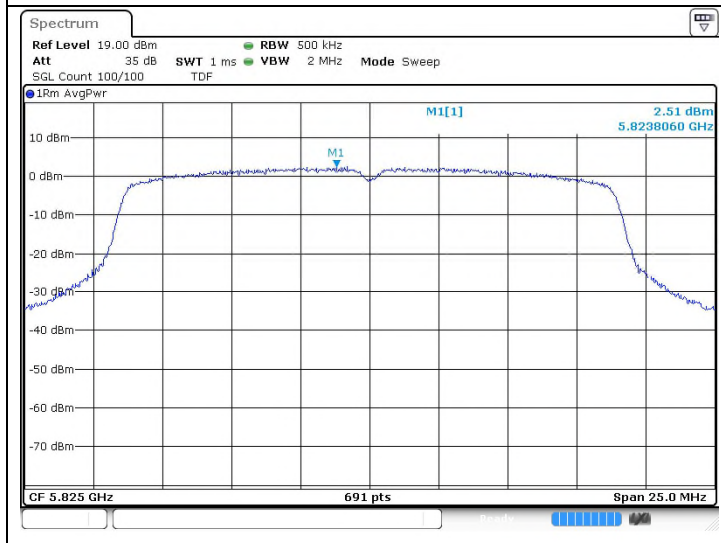



**802.11ac\_VHT40 (Band 3)**

Low Channel  
(5 755 MHz)

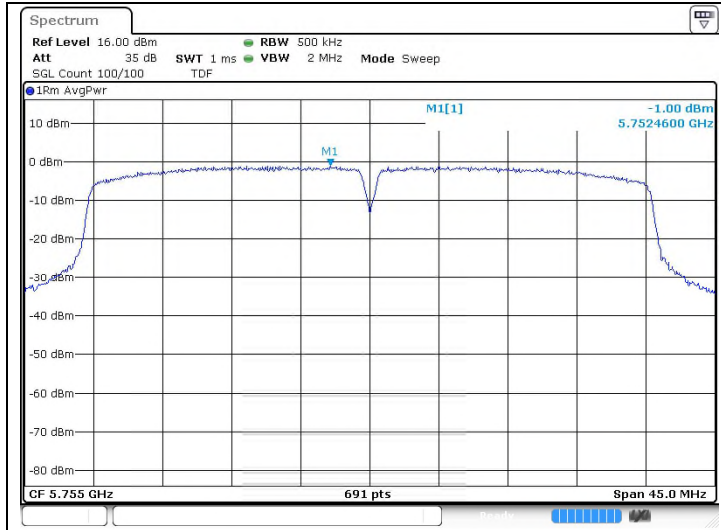

High Channel  
(5 795 MHz)

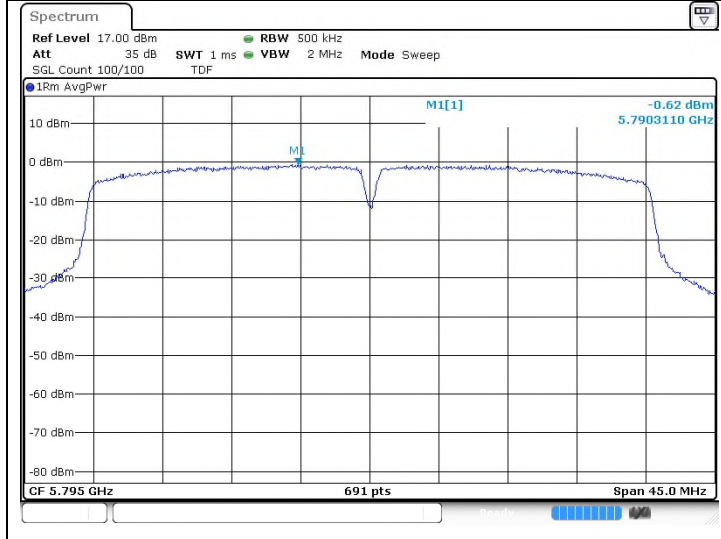

**802. 11ac\_VHT80 (Band 3)**

Middle Channel  
(5.775 MHz)

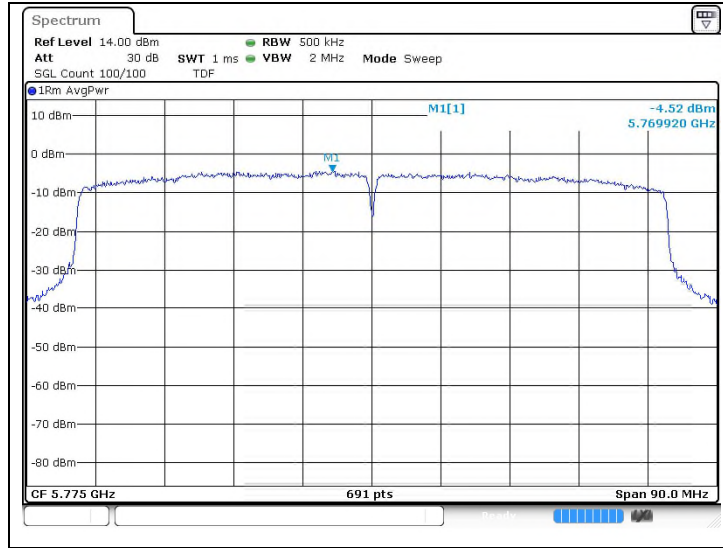

## 7. AC Power Line Conducted Emission

### 7.1. Test Setup

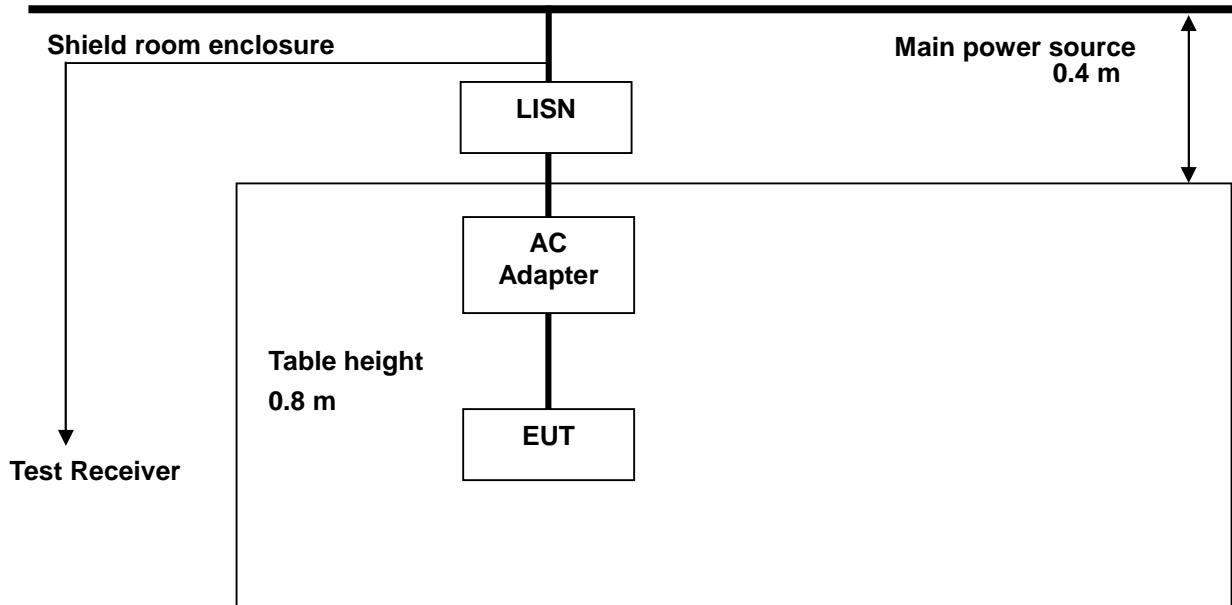

### 7.2. Limit

According to §15.207(a), for an intentional radiator that is designed to be connected to the public utility (AC) power line, the radio frequency voltage that is conducted back onto the AC power line on any frequency or frequencies, within the band 150 kHz to 30 MHz, shall not exceed the limits in the following table, as measured using a 50 μH /50 ohms line impedance stabilization network (LISN).

Compliance with the provision of this paragraph shall be based on the measurement of the radio frequency voltage between each power line and ground at the power terminal. The lower limit applies at the boundary between the frequency ranges.

Frequency of emission (MHz)	Conducted limit (dBμV)	
	Quasi-peak	Average
0.15-0.5	66 to 56*	56 to 46*
0.5-5	56	46
5-30	60	50

\* Decreases with the logarithm of the frequency.

### 7.3. Test Procedures

AC conducted emissions from the EUT were measured according to the dictates of ANSI C63.10-2013

1. The test procedure is performed in a 6.5 m × 3.5 m × 3.5 m (L × W × H) shielded room. The EUT along with its peripherals were placed on a 1.0 m (W) × 1.5 m (L) and 0.8 m in height wooden table and the EUT was adjusted to maintain a 0.4 meter space from a vertical reference plane.
2. The EUT was connected to power mains through a line impedance stabilization network (LISN) which provides 50 ohm coupling impedance for measuring instrument and the chassis ground was bounded to the horizontal ground plane of shielded room.
3. All peripherals were connected to the second LISN and the chassis ground also bounded to the horizontal ground plane of shielded room.
4. The excess power cable between the EUT and the LISN was bundled. The power cables of peripherals were unbundled. All connecting cables of EUT and peripherals were moved to find the maximum emission.

### 7.4. Test Results

The following table shows the highest levels of conducted emissions on both phase of Hot and Neutral line.

Ambient temperature : (23 ± 1) °C  
 Relative humidity : 47 % R.H.

Frequency range : 0.15 MHz - 30 MHz  
 Measured Bandwidth : 9 kHz

FREQ. (MHz)	LEVEL (dB $\mu$ V)		LINE	LIMIT (dB $\mu$ V)		MARGIN (dB)	
	Q-Peak	Average		Q-Peak	Average	Q-Peak	Average
0.19	30.00	12.60	N	64.04	54.04	34.04	41.44
0.31	26.70	16.50	N	59.97	49.97	33.27	33.47
1.10	37.30	30.20	N	56.00	46.00	18.70	15.80
2.27	34.30	26.10	N	56.00	46.00	21.70	19.90
4.28	37.70	27.10	N	56.00	46.00	18.30	18.90
20.60	38.00	26.00	N	60.00	50.00	22.00	24.00
0.16	28.50	11.40	H	65.46	55.46	36.96	44.06
0.32	27.40	19.70	H	59.71	49.71	32.31	30.01
2.27	28.50	21.90	H	56.00	46.00	27.50	24.10
5.03	27.70	21.40	H	60.00	50.00	32.30	28.60
13.84	28.40	22.50	H	60.00	50.00	31.60	27.50
20.57	29.30	20.90	H	60.00	50.00	30.70	29.10

**Remark;**

1. Line (H): Hot, Line (N): Neutral.
2. All data rates and modes of operation were investigated and the worst-case emissions were reported using **11ac VHT40 (Band 3) / MCS0 / High channel.**
3. The limit for Class B device(s) from 150 kHz to 30 MHz are specified in Section of the Title 47 CFR.
4. Traces shown in plot were made by using a peak detector and average detector.
5. Deviations to the Specifications: None.

**- Test plots**

Test mode: (Neutral)

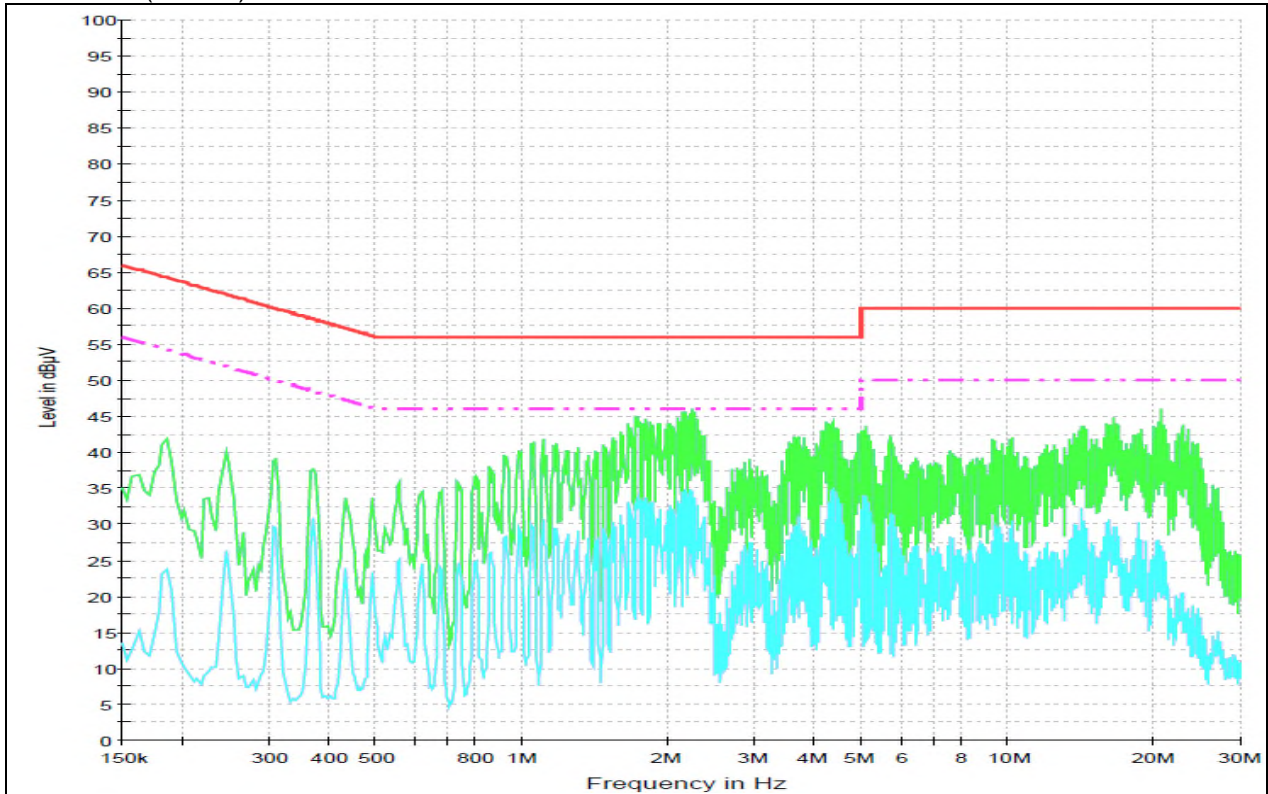

Test mode: (Hot)

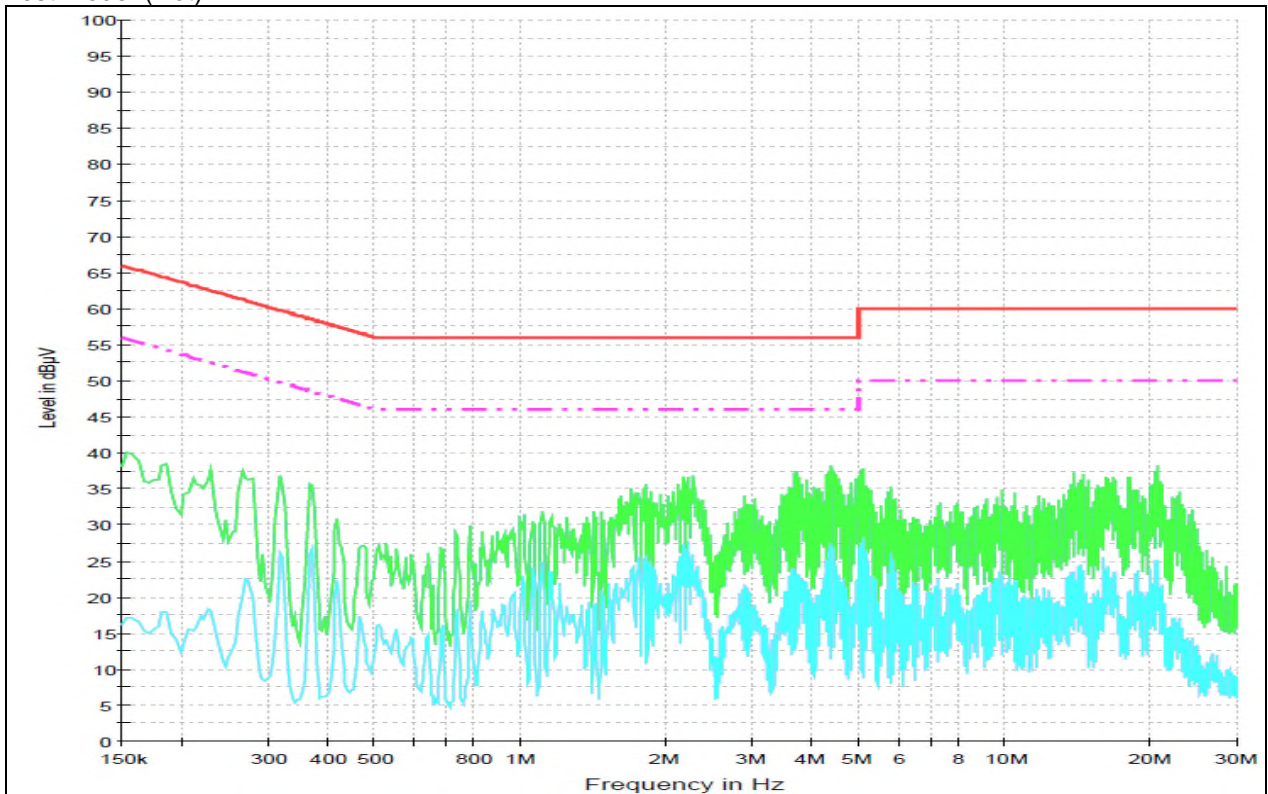

## 8. Antenna Requirement

### 8.1. Standard Applicable

For intentional device, according to FCC 47 CFR Section §15.203, an intentional radiator shall be designed to ensure that no antenna other than that furnished by the responsible party shall be used with the device. And according to FCC 47 CFR Section §15.407(a) if transmitting antennas of directional gain greater than 6 dB i are used, the power shall be reduced by the amount in dB that the gain of the antenna exceeds 6 dB i.

### 8.2. Antenna Connected Construction

Antenna used in this product is Pattern antenna and peak max gain of antenna as below.

<b>Band</b>	5 150 MHz ~ 5 250 MHz	5 725 MHz ~ 5 850 MHz
<b>Mode</b>	11n_HT20, HT40,	11ac_VHT20, VHT40, VHT80
<b>Gain</b>	4.69 dB i	3.00 dB i

- End of the Test Report -