



HCT CO., LTD.

Product Compliance Division

TEL : +82 31 639 8518 FAX : +82 31 639 8535

CERTIFICATE OF COMPLIANCE FCC Certification



| | |
|--|---|
| Applicant Name: Franklin Technology Inc. | Date of Issue: November 02, 2010 |
| Address: 1505 Digital Tower Aston, 505-15 Gasan-dong, Gumcheon-gu, Seoul, Korea | Location: HCT CO., LTD., 105-1, Jangam-ri, Majang-Myeon, Icheon-si, Kyunggi-Do, Korea(Lab) |
| | Test Report No.: HCTR1010FR13-2 |
| | HCT FRN: 0005866421 |
| | IC Recognition No.: IC 5944A-2 |

| | |
|------------------|-----------------------------------|
| FCC ID | : XHG-M600 |
| APPLICANT | : Franklin Technology Inc. |

| | |
|--------------------------------|---|
| Model(s): | M600 |
| EUT Type: | 3G 4G Module |
| Tx Frequency: | 2 498.5 MHz ~ 2 687.5 MHz (5 MHz Bandwidth) 2 501.0 MHz ~ 2 685.0 MHz (10 MHz Bandwidth) |
| Rx Frequency: | 2 498.5 MHz ~ 2 687.5 MHz (5 MHz Bandwidth) 2 501.0 MHz ~ 2 685.0 MHz (10 MHz Bandwidth) |
| Max. Conducted Power: | 0.195 W 5 MHz 16QAM(22.91 dBm)/ 0.195 W 5MHz QPSK(22.92 dBm)/ 0.188 W 10 MHz 16QAM(22.76 dBm)/ 0.194 W 10MHz QPSK(22.89 dBm) |
| Emission Designator(s): | 5 MHz BW : 4M39G7D (QPSK) / 4M45W7D(16QAM) 10 MHz BW : 9M13G7D (QPSK) / 9M05W7D(16QAM) |
| FCC Classification: | Licensed Non-Broadcast Transmitter (TNB) |
| FCC Rule Part(s): | §27, §2 |

The measurements shown in this report were made in accordance with the procedures specified in §2.947. I assume full responsibility for the accuracy and completeness of these measurements, and for the qualifications of all persons taking them.

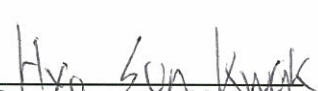
HCT CO., LTD. Certifies that no party to this application has subject to a denial of Federal benefits that includes FCC benefits pursuant to section 5301 of the Anti-Drug Abuse Act of 1998,21 U.S. C.853(a)

| | |
|--|---|
|  Report prepared by : Hyo Sun Kwak Test engineer of RF Team |  Approved by : Sang Jun Lee Manager of RF Team |
|--|---|

This report only responds to the tested sample and may not be reproduced, except in full, without written approval of the HCT Co., Ltd.

| FCC CERTIFICATION REPORT | | | www.hct.co.kr |
|-----------------------------------|-------------------------------------|---------------------------|--|
| Test Report No. HCTR1010FR13-2 | Date of Issue: November 02, 2010 | EUT Type: 3G 4G Module | FCC ID: XHG-M600 |



Version

| TEST REPORT NO. | DATE | DESCRIPTION |
|-----------------|-------------------|-----------------------------------|
| HCTR1010FR13 | October 19, 2010 | First Approval Report |
| HCTR1010FR13-1 | October 29, 2010 | Change the test site description. |
| HCTR1010FR13-2 | November 02, 2010 | Delete EIRP Test |
| | | |
| | | |



Table of Contents

| | |
|--|----|
| 1. GENERAL INFORMATION | 4 |
| 2. INTRODUCTION | 5 |
| 2.1. EUT DESCRIPTION..... | 5 |
| 2.2. MEASURING INSTRUMENT CALIBRATION..... | 5 |
| 2.3. TEST FACILITY | 5 |
| 3. DESCRIPTION OF TESTS | 6 |
| 3.1 EQUIVALENT ISOTROPIC RADIATED POWER | 6 |
| 3.2 OCCUPIED BANDWIDTH. | 7 |
| 3.3 SPURIOUS AND HARMONIC EMISSIONS AT ANTENNA TERMINAL..... | 8 |
| 3.4 RADIATED SPURIOUS AND HARMONIC EMISSIONS | 9 |
| 3.5 FREQUENCY STABILITY / VARIATION OF AMBIENT TEMPERATURE | 10 |
| 4. LIST OF TEST EQUIPMENT | 11 |
| 5. SUMMARY OF TEST RESULTS | 12 |
| 6. SAMPLE CALCULATION..... | 13 |
| 7. TEST DATA | 14 |
| 7.1 CONDUCTED OUTPUT POWER | 14 |
| 7.2 OCCUPIED BANDWIDTH | 16 |
| 7.3 CONDUCTED SPURIOUS EMISSIONS | 18 |
| 7.3.1 CHANNEL EDGE | 19 |
| 7.4 RADIATED SPURIOUS EMISSIONS..... | 20 |
| 7.4.1 RADIATED SPURIOUS EMISSIONS (WiMAX 5 MHz-QPSK)..... | 20 |
| 7.4.2 RADIATED SPURIOUS EMISSIONS (WiMAX 10 MHz-16QAM)..... | 21 |
| 7.5 FREQUENCY STABILITY / VARIATION OF AMBIENT TEMPERATURE | 22 |
| 7.5.1 FREQUENCY STABILITY (WiMAX-5 MHz) | 22 |
| 7.5.2 FREQUENCY STABILITY (WiMAX-10 MHz) | 23 |
| 8. TEST PLOTS..... | 24 |

| | | | |
|-----------------------------------|-------------------------------------|---------------------------|--|
| FCC CERTIFICATION REPORT | | | www.hct.co.kr |
| Test Report No. HCTR1010FR13-2 | Date of Issue: November 02, 2010 | EUT Type: 3G 4G Module | FCC ID: XHG-M600 |



MEASUREMENT REPORT

1. GENERAL INFORMATION

Applicant Name: Franklin Technology Inc.

Address: 1505 Digital Tower Aston, 505-15 Gasan-dong, Gumcheon-gu, Seoul, Korea

FCC ID: XHG-M600

Application Type: Certification

FCC Classification: Licensed Non-Broadcast Transmitter (TNB)

FCC Rule Part(s): §27, §2

EUT Type: 3G 4G Module

Model(s): M600

Tx Frequency: 2 498.5 MHz ~ 2 687.5 MHz (5 MHz Bandwidth)
2 501.0 MHz ~ 2 685.0 MHz (10 MHz Bandwidth)

Rx Frequency: 2 498.5 MHz ~ 2 687.5 MHz (5 MHz Bandwidth)
2 501.0 MHz ~ 2 685.0 MHz (10 MHz Bandwidth)

Max. Conducted Power: 0.195 W 5 MHz 16QAM(22.91 dBm)/ 0.195 W 5MHz QPSK(22.92 dBm)/
0.188 W 10 MHz 16QAM(22.76 dBm)/ 0.194 W 10MHz QPSK(22.89 dBm)

Emission Designator(s): 5 MHz BW : 4M39G7D (QPSK) / 4M45W7D(16QAM)
10 MHz BW : 9M13G7D (QPSK) / 9M05W7D(16QAM)

Date(s) of Tests: October 05, 2010 ~ October 15, 2010

| FCC CERTIFICATION REPORT | | | www.hct.co.kr |
|--|--|----------------------------------|--|
| Test Report No. HCTR1010FR13-2 | Date of Issue: November 02, 2010 | EUT Type: 3G 4G Module | FCC ID: XHG-M600 |



2. INTRODUCTION

2.1. EUT DESCRIPTION

The Diffon Corporation M600 3G 4G Module consists of Cellular CDMA, PCS CDMA, EVDO Rev.A and **wimax**.

2.2. MEASURING INSTRUMENT CALIBRATION

The measuring equipment, which was utilized in performing the tests documented herein, has been calibrated in accordance with the manufacturer's recommendations for utilizing calibration equipment, which is traceable to recognized national standards.

2.3. TEST FACILITY

The SAC(Semi-Anechoic Chamber) and conducted measurement facility used to collect the radiated data are located at the 105-1, Jangam-ri , Majang-Myeon, Icheon-si, 467-811, KOREA.

The site is constructed in conformance with the requirements of ANSI C63.4 and CISPR Publication 22. Detailed description of test facility was submitted to the Commission and accepted dated June 10, 2009 (Registration Number: 90661)

| FCC CERTIFICATION REPORT | | | www.hct.co.kr |
|-----------------------------------|-------------------------------------|---------------------------|--|
| Test Report No. HCTR1010FR13-2 | Date of Issue: November 02, 2010 | EUT Type: 3G 4G Module | FCC ID: XHG-M600 |

3. DESCRIPTION OF TESTS

3.1 EQUIVALENT ISOTROPIC RADIATED POWER

Test Set-up

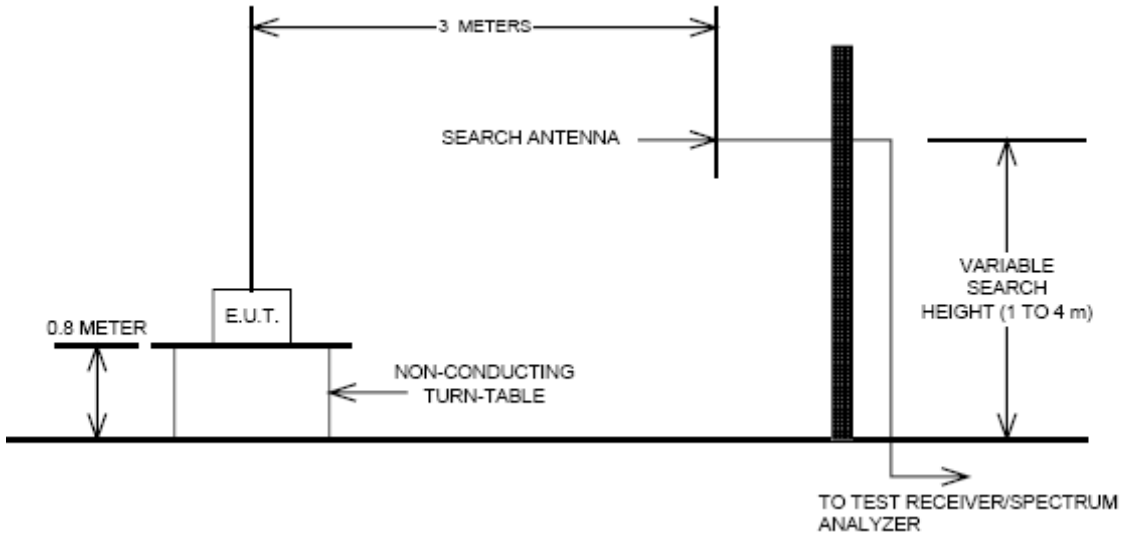

Test Procedure

Radiated emission measurements were performed at an SAC(Semi-Anechoic Chamber)

The equipment under test is placed on a non-conductive styrofoam resin table 3-meters from the receive antenna. A styrofoam turntable was rotated 360° and the receiving antenna scanned from 1-4m in order to capture the maximum emission. A half wave dipole was substituted in place of the EUT. This dipole antenna was driven by a signal generator and the previously recorded signal was duplicated.

The maximum EIRP was calculated by adding the forward power to the calibrated source plus its appropriate gain value. These steps were carried out with the receiving antenna in both vertical and horizontal polarization. For readings above 1GHz, the above procedure is repeated using horn antennas and the difference between the gain of the horn and an isotropic antenna are taken into consideration.

| FCC CERTIFICATION REPORT | | | www.hct.co.kr |
|-----------------------------------|-------------------------------------|---------------------------|--|
| Test Report No. HCTR1010FR13-2 | Date of Issue: November 02, 2010 | EUT Type: 3G 4G Module | FCC ID: XHG-M600 |

3.2 OCCUPIED BANDWIDTH.

Test set-up

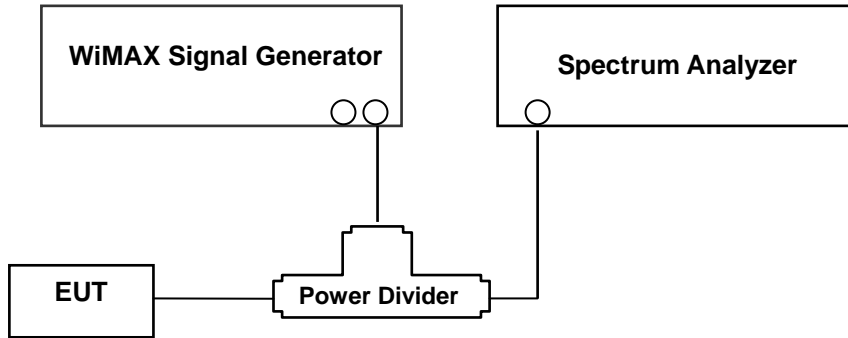

(Configuration of conducted Emission measurement)

Test Procedure

The EUT was setup to maximum output power at its lowest channel. The occupied bandwidth was measured using a spectrum analyzer. The measurements are repeated for the highest and a middle channel. The EUT's occupied bandwidth is measured as the width of the signal between two points, one below the carrier center frequency and one above the carrier frequency, outside of which all emissions are attenuated at least 26 dB below the transmitter power. Plots of the EUT's occupied bandwidth are shown herein.

| FCC CERTIFICATION REPORT | | | www.hct.co.kr |
|-----------------------------------|-------------------------------------|---------------------------|--|
| Test Report No. HCTR1010FR13-2 | Date of Issue: November 02, 2010 | EUT Type: 3G 4G Module | FCC ID: XHG-M600 |



3.3 SPURIOUS AND HARMONIC EMISSIONS AT ANTENNA TERMINAL.

Test Procedure

The level of the carrier and the various conducted spurious and harmonic frequencies is measured by means of a calibrated spectrum analyzer.

The EUT was setup to maximum output power at its lowest channel. The Resolution BW of the analyzer is set to 1 % of the emission bandwidth to show compliance with the -13 dBm limit, in the 1 MHz bands immediately outside and adjacent to the edge of the frequency block. The 1 MHz RBW was used to scan from 30 MHz to 26.5 GHz.. A display line was placed at -25 dBm to show compliance. The high, lowest and a middle channel were tested for out of band measurements.

- Band Edge Requirement : When measuring conducted band edge, the ACP feature of the signal analyzer was used. For each segment of the band edge, the allowed integration bandwidth was configured to calculate the channel power that is highest within that band edge segment.

- Occupied Bandwidth Emission Limits

· On any frequency outside but within 5.5 MHz from the band edge of a licensee's frequency block, the power of any emission shall be attenuated below the transmitter power (P) by at least $43 + 10\log(P)$ dB. At frequencies greater than 5.5 MHz from any in-band channel edge, the transmitter power (P) shall be attenuated by at least $55 + 10\log(P)$ dB.

· Compliance with these provisions is based on the use of measurement instrumentation employing a resolution bandwidth of 1 MHz or greater. However, in the 1 MHz bands immediately outside and adjacent to the frequency block a resolution bandwidth of at least one percent of the emission bandwidth of the fundamental emission of the transmitter may be employed. The emission bandwidth is defined as the width of the signal between two points, one below the carrier center frequency and one above the carrier center frequency, outside of which all emission are attenuated at least 26 dB below the transmitter power.

· When measuring the emission limits, the nominal carrier frequency shall be adjusted as close to the licensee's frequency block edges, both upper and lower, as the design permits.

· The measurement of emission power can be expressed in peak or average values, provided they are expressed in the same parameters as the transmitter power.

| FCC CERTIFICATION REPORT | | | www.hct.co.kr |
|-----------------------------------|-------------------------------------|---------------------------|--|
| Test Report No. HCTR1010FR13-2 | Date of Issue: November 02, 2010 | EUT Type: 3G 4G Module | FCC ID: XHG-M600 |

3.4 RADIATED SPURIOUS AND HARMONIC EMISSIONS

Test Set-up

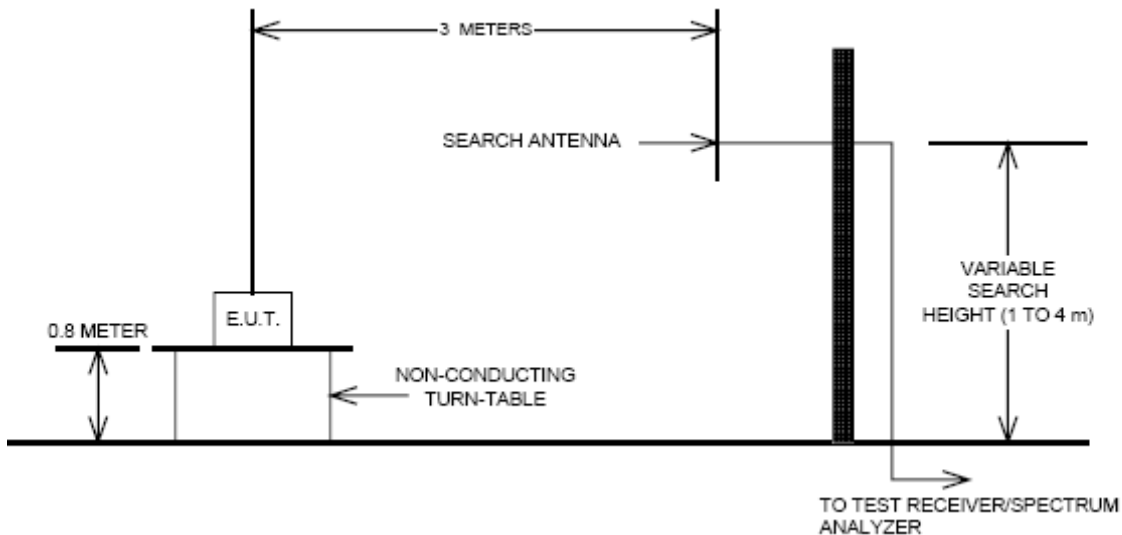

The measurement facilities used for this test have been documented in previous filings with the commission pursuant to section § 2.948. The SAC(Semi-Anechoic Chamber) meets requirements in ANSI C63.4 –2003. A mast capable of lifting the receiving antenna from a height of one to four meters is used together with a rotatable styrofoam platform mounted at three from the antenna mast.

- 1) The unit mounted on a styrofoam turntable 1.5 m × 1.0 m × 0.80 m is 0.8 meter above test site ground level.
- 2) During the emission test, the turntable is rotated and the EUT is manipulated to find the configuration resulting in maximum emission under normal condition of installation and operation.
- 3) The antenna height and polarization are also varied from 1 to 4 meters until the maximum signal is found.
- 4) The spectrum shall be scanned up to the 10th harmonic of the fundamental frequency.

Test Procedure

The equipment under test is placed on a non-conductive styrofoam resin table 3-meters from the receive antenna. A styrofoam turntable was rotated 360° and the receiving antenna scanned from 1-4m in order to capture the maximum emission. A half wave dipole was substituted in place of the EUT. This dipole antenna was driven by a signal generator and the previously recorded signal was duplicated.

The maximum EIRP was calculated by adding the forward power to the calibrated source plus its appropriate gain value. These steps were carried out with the receiving antenna in both vertical and horizontal polarization. For readings above 1GHz, the above procedure is repeated using horn antennas and the difference between the gain of the horn and an isotropic antenna are taken into consideration.

| FCC CERTIFICATION REPORT | | | www.hct.co.kr |
|-----------------------------------|-------------------------------------|---------------------------|--|
| Test Report No. HCTR1010FR13-2 | Date of Issue: November 02, 2010 | EUT Type: 3G 4G Module | FCC ID: XHG-M600 |

3.5 FREQUENCY STABILITY / VARIATION OF AMBIENT TEMPERATURE

Test Set-up

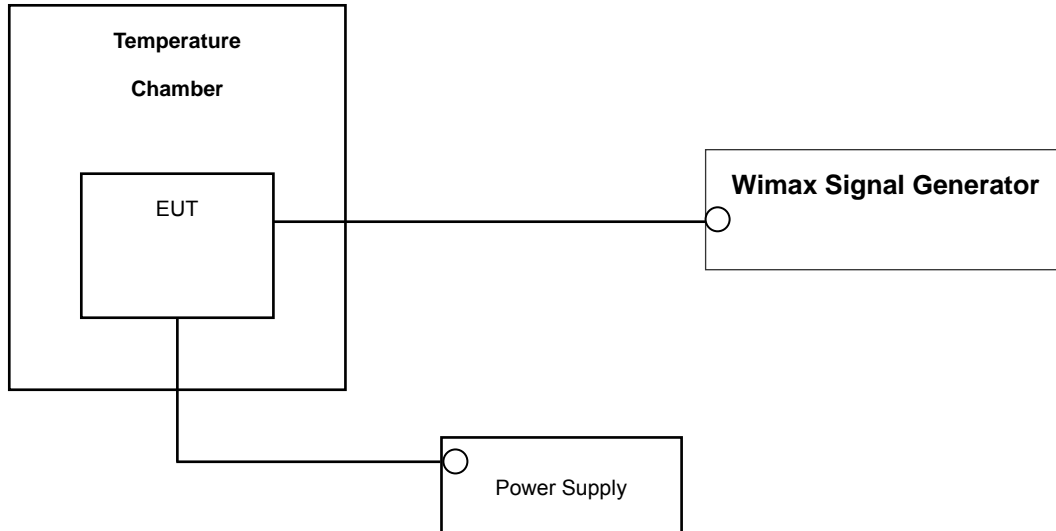

* Nominal Operating Voltage

Test Procedure

The frequency stability of the transmitter is measured by:

- a.) **Temperature:** The temperature is varied from - 30 °C to + 50 °C using an environmental chamber.
- b.) **Primary Supply Voltage:** The primary supply voltage is varied from battery end point to 115 % of the voltage normally at the input to the device or at the power supply terminals if cables are not normally supplied.

Specification — the frequency stability shall be sufficient to ensure that the fundamental emission stays within the authorized frequency block. The frequency stability of the transmitter shall be maintained within $\pm 0.00025\%$ (± 2.5 ppm) of the center frequency.

Time Period and Procedure:

The carrier frequency of the transmitter is measured at room temperature (20°C to provide a reference).

1. The equipment is turned on in a “standby” condition for one minute before applying power to the transmitter. Measurement of the carrier frequency of the transmitter is made within one minute after applying power to the transmitter.
2. Frequency measurements are made at 10°C intervals ranging from -30°C to +50°C. A period of at least one half-hour is provided to allow stabilization of the equipment at each temperature level.

NOTE: The EUT is tested down to the battery endpoint.

| FCC CERTIFICATION REPORT | | | www.hct.co.kr |
|-----------------------------------|-------------------------------------|---------------------------|--|
| Test Report No. HCTR1010FR13-2 | Date of Issue: November 02, 2010 | EUT Type: 3G 4G Module | FCC ID: XHG-M600 |



4. LIST OF TEST EQUIPMENT

| Manufacture | Model/ Equipment | Serial Number | Calibration Interval | Calibration Due |
|-------------------|--------------------------------|---------------|----------------------|-----------------|
| R&S | ESI40/ Spectrum Analyzer | 831564/003 | Annual | 10/30/2010 |
| Agilent | E4416A/ Power Meter | GB41291412 | Annual | 01/14/2011 |
| Agilent | E9327A/ Power Sensor | MY4442009 | Annual | 07/23/2011 |
| Agilent | E4438C / SIGNAL GENERATOR | GB44400269 | Annual | 02/10/2011 |
| MITEQ | AMF-6D-001180-35-20P/AMP | 990893 | Annual | 05/20/2011 |
| Wainwright | WHK1.2/15G-10EF/H.P.F | 2 | Annual | 06/25/2011 |
| Wainwright | WHK3.3/18G-10EF/H.P.F | 1 | Annual | 06/25/2011 |
| Agilent | 775D/ Dual Directional Coupler | 12922 | Annual | 12/24/2010 |
| Agilent | 11636B/ Power Divider | 11377 | Annual | 12/24/2010 |
| Digital | EP-3010/ Power Supply | 3110117 | Annual | 01/08/2011 |
| Schwarzbeck | UHAP/ Dipole Antenna | 585 | Biennial | 02/13/2011 |
| Schwarzbeck | UHAP/ Dipole Antenna | 558 | Biennial | 02/13/2011 |
| Korea Engineering | KR-1005L / Chamber | KRAB07063-2CH | Annual | 12/28/2010 |
| Schwarzbeck | BBHA 9120D/ Horn Antenna | 296 | Biennial | 09/23/2011 |
| Agilent | N9020A / Spectrum Analyzer | US45303008 | Annual | 06/09/2011 |

| FCC CERTIFICATION REPORT | | | www.hct.co.kr |
|-----------------------------------|-------------------------------------|---------------------------|--|
| Test Report No. HCTR1010FR13-2 | Date of Issue: November 02, 2010 | EUT Type: 3G 4G Module | FCC ID: XHGM600 |



5. SUMMARY OF TEST RESULTS

| FCC Part Section(s) | Test Description | Test Limit | Test Condition | Test Result |
|------------------------|-------------------------------------|--|----------------|-------------|
| 2.1049, 27.53(l)(6) | Occupied Bandwidth | N/A | CONDUCTED | PASS |
| 2.1051, 27.53(l)(4)(6) | Band Edge | < 43 + 10log ₁₀ (P[Watts]) within 5.5MHz from the band edge | | PASS |
| 2.1046 | Conducted Output Power | N/A | | PASS |
| 2.1051, 27.53(l)(4)(6) | Conducted Spurious Emissions | < 55 + 10log ₁₀ (P[Watts]) for all emissions greater than 5.5MHz from the band edge | | PASS |
| 2.1055, 27.54 | Frequency stability | Fundamental emissions must stay within the allotted band | | PASS |
| 27.50(h)(2) | Equivalent Isotropic Radiated Power | < 2 Watts max. EIRP | RADIATED | PASS |
| 2.1053, 27.53(l)(4) | Undesirable Emissions | < 55 + 10log ₁₀ (P[Watts]) for all out-of-band emissions | | PASS |

| FCC CERTIFICATION REPORT | | | www.hct.co.kr |
|-----------------------------------|-------------------------------------|---------------------------|--|
| Test Report No. HCTR1010FR13-2 | Date of Issue: November 02, 2010 | EUT Type: 3G 4G Module | FCC ID: XHG-M600 |



6. SAMPLE CALCULATION

A. ERP Sample Calculation

| Mode | Ch./ Freq. | | Measured | Substitute | Ant. Gain | C.L | Pol. | ERP | |
|------|------------|------------|------------|------------|-----------|------|------|------|-------|
| | channel | Freq.(MHz) | Level(dBm) | LEVEL(dBm) | | | | W | dBm |
| CDMA | 384 | 836.52 | -10.96 | 24.81 | 2.50 | 1.19 | H | 0.41 | 26.12 |

ERP = SubstituteLEVEL(dBm) + Ant. Gain – CL(Cable Loss)

- 1) The EUT mounted on a wooden tripod is 0.8 meter above test site ground level.
- 2) During the test , the turn table is rotated and the antenna height is also varied from 1 to 4 meters until the maximum signal is found.
- 3) Record the field strength meter's level.
- 4) Replace the EUT with dipole/Horn antenna that is connected to a calibrated signal generator.
- 5) Increase the signal generator output till the field strength meter's level is equal to the item (3).
- 6) The signal generator output level with Ant. Gain and cable loss are the rating of effective radiated power (ERP).

B. Emission Designator

CDMA Emission Designator

Emission Designator = 1M27F9W

CDMA BW = 1.27 MHz (Measured at the 99% power bandwidth)

F = Frequency Modulation

9 = Composite Digital Info

W = Combination (Audio/Data)

| FCC CERTIFICATION REPORT | | | www.hct.co.kr |
|-----------------------------------|-------------------------------------|---------------------------|--|
| Test Report No. HCTR1010FR13-2 | Date of Issue: November 02, 2010 | EUT Type: 3G 4G Module | FCC ID: XHG-M600 |

7. TEST DATA

7.1 CONDUCTED OUTPUT POWER

A base station simulator was used to establish communication with the EUT. The base station simulator parameters were set to produce the maximum power from the EUT. This device was tested under all configurations and the highest power is reported. Conducted Output Powers of EUT are reported below.

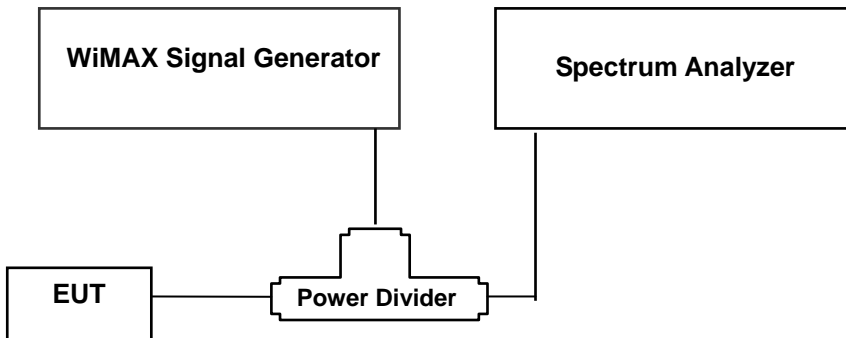

Test Result

| 5 MHz channel BW | | |
|------------------|------------|---------------------|
| Frequency(MHz) | Modulation | Average Power (dBm) |
| 2498.5 | QPSK 1/2 | 22.58 |
| | QPSK 3/4 | 22.57 |
| | 16QAM 1/2 | 22.60 |
| | 16QAM 3/4 | 22.59 |
| 2593.0 | QPSK 1/2 | 22.78 |
| | QPSK 3/4 | 22.72 |
| | 16QAM 1/2 | 22.78 |
| | 16QAM 3/4 | 22.64 |
| 2687.5 | QPSK 1/2 | 22.80 |
| | QPSK 3/4 | 22.92 |
| | 16QAM 1/2 | 22.91 |
| | 16QAM 3/4 | 22.73 |

(WiMAX Conducted Average Output Powers)



| 10 MHz channel BW | | |
|-------------------|------------|---------------------|
| Frequency(MHz) | Modulation | Average Power (dBm) |
| 2501.0 | QPSK 1/2 | 22.62 |
| | QPSK 3/4 | 22.57 |
| | 16QAM 1/2 | 22.53 |
| | 16QAM 3/4 | 22.51 |
| 2593.0 | QPSK 1/2 | 22.78 |
| | QPSK 3/4 | 22.74 |
| | 16QAM 1/2 | 22.73 |
| | 16QAM 3/4 | 22.65 |
| 2685.0 | QPSK 1/2 | 22.89 |
| | QPSK 3/4 | 22.81 |
| | 16QAM 1/2 | 22.71 |
| | 16QAM 3/4 | 22.76 |

(WiMAX Conducted Average Output Powers)

Note : Detecting mode is average.

- 5 MHz: Plots of the EUT's Conducted Output Power are shown Page 25 ~ 30.

- 10 MHz: Plots of the EUT's Conducted Output Power are shown Page 31 ~ 36.

| FCC CERTIFICATION REPORT | | | www.hct.co.kr |
|-----------------------------------|-------------------------------------|---------------------------|--|
| Test Report No. HCTR1010FR13-2 | Date of Issue: November 02, 2010 | EUT Type: 3G 4G Module | FCC ID: XHG-M600 |



7.2 OCCUPIED BANDWIDTH

5 MHz

| Frequency [MHz] | Modulation | Occupied Bandwidth [MHz] |
|-----------------|------------|--------------------------|
| 2498.5 | QPSK 1/2 | 4.3833 |
| | QPSK 3/4 | 4.3941 |
| | 16QAM 1/2 | 4.4482 |
| | 16QAM 3/4 | 4.4234 |
| 2593.0 | QPSK 1/2 | 4.3717 |
| | QPSK 3/4 | 4.3919 |
| | 16QAM 1/2 | 4.4446 |
| | 16QAM 3/4 | 4.4219 |
| 2687.5 | QPSK 1/2 | 4.3670 |
| | QPSK 3/4 | 4.3881 |
| | 16QAM 1/2 | 4.4413 |
| | 16QAM 3/4 | 4.4207 |



10 MHz

| Frequency [MHz] | Modulation | Occupied Bandwidth [MHz] |
|-----------------|------------|--------------------------|
| 2501.0 | QPSK 1/2 | 9.1319 |
| | QPSK 3/4 | 8.9703 |
| | 16QAM 1/2 | 8.9662 |
| | 16QAM 3/4 | 9.0516 |
| 2593.0 | QPSK 1/2 | 9.1289 |
| | QPSK 3/4 | 8.9658 |
| | 16QAM 1/2 | 8.9592 |
| | 16QAM 3/4 | 9.0430 |
| 2685.0 | QPSK 1/2 | 9.0404 |
| | QPSK 3/4 | 8.9609 |
| | 16QAM 1/2 | 8.9563 |
| | 16QAM 3/4 | 9.0402 |

- 5 MHz: Plots of the EUT's Occupied Bandwidth are shown Page 37 ~ 42.

- 10 MHz: Plots of the EUT's Occupied Bandwidth are shown Page 43 ~ 48.



7.3 CONDUCTED SPURIOUS EMISSIONS

5 MHz

| Frequency(MHz) | Modulation | Frequency of Maximum Harmonic (GHz) | Maximum Data (dBm) |
|----------------|------------|-------------------------------------|--------------------|
| 2498.5 | QPSK 1/2 | 25.965 | -35.030 |
| | QPSK 3/4 | 25.123 | -34.533 |
| | 16QAM 1/2 | 24.409 | -34.413 |
| | 16QAM 3/4 | 25.633 | -34.833 |
| 2593.0 | QPSK 1/2 | 25.047 | -34.126 |
| | QPSK 3/4 | 25.735 | -34.164 |
| | 16QAM 1/2 | 25.965 | -35.030 |
| | 16QAM 3/4 | 25.123 | -34.533 |
| 2687.5 | QPSK 1/2 | 2.428 | -28.967 |
| | QPSK 3/4 | 2.428 | -28.534 |
| | 16QAM 1/2 | 2.428 | -28.510 |
| | 16QAM 3/4 | 2.428 | -28.679 |



10 MHz

| Frequency(MHz) | Modulation | Frequency of Maximum Harmonic (GHz) | Maximum Data (dBm) |
|----------------|------------|-------------------------------------|--------------------|
| 2501.0 | QPSK 1/2 | 26.143 | -33.711 |
| | QPSK 3/4 | 25.659 | -33.797 |
| | 16QAM 1/2 | 25.098 | -30.192 |
| | 16QAM 3/4 | 25.863 | -29.849 |
| 2593.0 | QPSK 1/2 | 25.608 | -33.256 |
| | QPSK 3/4 | 25.710 | -34.330 |
| | 16QAM 1/2 | 25.047 | -33.529 |
| | 16QAM 3/4 | 25.276 | -34.283 |
| 2685.0 | QPSK 1/2 | 2.428 | -32.183 |
| | QPSK 3/4 | 2.428 | -31.930 |
| | 16QAM 1/2 | 2.428 | -31.571 |
| | 16QAM 3/4 | 2.428 | -32.528 |

- 5 MHz: Plots of the EUT's Conducted Spurious Emissions are shown Page 57 ~ 68.

- 10 MHz: Plots of the EUT's Conducted Spurious Emissions are shown Page 69 ~ 80.

7.3.1 CHANNEL EDGE

- 5 MHz: Plots of the EUT's Band Edge are shown Page 49 ~ 52.

- 10 MHz: Plots of the EUT's Band Edge are shown Page 53 ~ 56.



7.4 RADIATED SPURIOUS EMISSIONS

7.4.1 RADIATED SPURIOUS EMISSIONS (WiMAX 5 MHz-QPSK)

- MEASURED OUTPUT POWER: 27.84 dBm = 0.608 W
- MODULATION SIGNAL: WiMAX 5 MHz
- DISTANCE: 3 meters
- LIMIT: $-(43 + 10 \log_{10}(W)) =$ - 52.84 dBc

| Operating Freq. (MHz) | Freq.(MHz) | Measured Level [dBm] | Ant. Gain (dBd) | Substitute Level [dBm] | C.L | Pol. | ERP (dBm) | dBc |
|-----------------------|------------|----------------------|-----------------|------------------------|------|------|-----------|--------|
| 2498.50 | 4,997.00 | -44.48 | 12.42 | -45.75 | 3.60 | H | -36.93 | -67.33 |
| | 7,495.50 | -44.97 | 11.36 | -37.40 | 3.88 | H | -29.92 | -60.32 |
| | 9,994.00 | - | - | - | - | - | - | - |
| 2593.00 | 5,186.00 | -40.96 | 12.51 | -42.33 | 3.39 | H | -33.21 | -63.61 |
| | 7,779.00 | -47.56 | 11.26 | -40.45 | 3.72 | H | -32.91 | -63.31 |
| | 10,372.00 | - | - | - | - | - | - | - |
| 2687.50 | 5,375.00 | -41.67 | 12.62 | -44.23 | 3.41 | H | -35.02 | -65.42 |
| | 8,062.50 | -43.43 | 11.21 | -34.02 | 4.07 | H | -26.88 | -57.28 |
| | 10,750.00 | - | - | - | - | - | - | - |

- NOTES:**
1. Radiated Spurious Emission Measurements at 3 meters by Substitution Method according to ANSI/TIA/EIA-603-C-2004, Aug. 17, 2004:
 2. The magnitude of spurious emissions attenuated more than 20dB below the limit above 5th Harmonic for all channel.
 3. we have done x, y, z planes in EUT and horizontal and vertical polarization in detecting antenna.
 4. Worst case is QPSK 3/4.

| FCC CERTIFICATION REPORT | | | www.hct.co.kr |
|-----------------------------------|-------------------------------------|---------------------------|--|
| Test Report No. HCTR1010FR13-2 | Date of Issue: November 02, 2010 | EUT Type: 3G 4G Module | FCC ID: XHG-M600 |



7.4.2 RADIATED SPURIOUS EMISSIONS (WiMAX 10 MHz-16QAM)

- MEASURED OUTPUT POWER: 30.20 dBm = 1.047 W
- MODULATION SIGNAL: WiMAX 10 MHz
- DISTANCE: 3 meters
- LIMIT: - (43 + 10 log₁₀(W)) = - 55.20 dBc

| Operating Freq. (MHz) | Freq.(MHz) | Measured Level [dBm] | Ant. Gain (dBd) | Substitute Level [dBm] | C.L | Pol. | ERP (dBm) | dBc |
|-----------------------|------------|----------------------|-----------------|------------------------|------|------|-----------|--------|
| 2501.00 | 5,002.00 | -47.07 | 12.41 | -48.73 | 3.60 | H | -39.92 | -65.15 |
| | 7,503.00 | -49.50 | 11.33 | -42.00 | 3.88 | H | -34.55 | -59.78 |
| | 10,004.00 | - | - | - | - | - | - | - |
| 2593.00 | 5,186.00 | -45.71 | 12.51 | -47.08 | 3.39 | H | -37.96 | -63.19 |
| | 7,779.00 | -51.71 | 11.26 | -44.60 | 3.72 | H | -37.06 | -62.29 |
| | 10,372.00 | - | - | - | - | - | - | - |
| 2685.00 | 5,370.00 | -45.28 | 12.62 | -47.94 | 3.41 | H | -38.73 | -63.96 |
| | 8,055.00 | -50.61 | 11.21 | -41.00 | 4.07 | H | -33.86 | -59.09 |
| | 10,740.00 | - | - | - | - | - | - | - |

- NOTES:**
1. Radiated Spurious Emission Measurements at 3 meters by Substitution Method according to ANSI/TIA/EIA-603-C-2004, Aug. 17, 2004:
 2. The magnitude of spurious emissions attenuated more than 20dB below the limit above 5th Harmonic for all channel.
 3. we have done x, y, z planes in EUT and horizontal and vertical polarization in detecting antenna.
 4. Worst case is 16QAM 3/4.

| | | | |
|--|--|----------------------------------|--|
| FCC CERTIFICATION REPORT | | | www.hct.co.kr |
| Test Report No. HCTR1010FR13-2 | Date of Issue: November 02, 2010 | EUT Type: 3G 4G Module | FCC ID: XHG-M600 |



7.5 FREQUENCY STABILITY / VARIATION OF AMBIENT TEMPERATURE

7.5.1 FREQUENCY STABILITY (WiMAX-5 MHz)

OPERATING FREQUENCY: 2593,000,000 Hz
 REFERENCE VOLTAGE: 3.7 VDC
 DEVIATION LIMIT: ± 0.000 25 % or 2.5 ppm

| Voltage (%) | Power (VDC) | Temp. (°C) | Frequency (Hz) | Frequency Error (Hz) | Deviation (%) | ppm |
|----------------|-------------|------------|----------------|----------------------|---------------|-----------|
| 100% | 5.0 V | +20(Ref) | 2592 999 997 | 0 | 0.000 000 | 0.000 |
| 100% | | -30 | 2592 999 998 | -2.4 | 0.000 000 | -0.001 |
| 100% | | -20 | 2592 999 999 | -1.0 | 0.000 000 | 0.000 |
| 100% | | -10 | 2592 999 997 | -3.4 | 0.000 000 | -0.001 |
| 100% | | 0 | 2593 000 004 | 3.7 | 0.000 000 | 0.001 |
| 100% | | +10 | 2593 000 003 | 3.3 | 0.000 000 | 0.001 |
| 100% | | +30 | 2593 000 008 | 7.9 | 0.000 000 | 0.003 |
| 100% | | +40 | 2593 000 012 | 12.0 | 0.000 000 | 0.005 |
| 100% | | +50 | 2593 000 017 | 17.0 | 0.000 001 | 0.007 |
| 115% | | 5.75 | +20 | 2593 000 003 | 2.8 | 0.000 000 |
| Batt. Endpoint | 4.25 | +20 | 2593 000 005 | 4.5 | 0.000 000 | 0.002 |

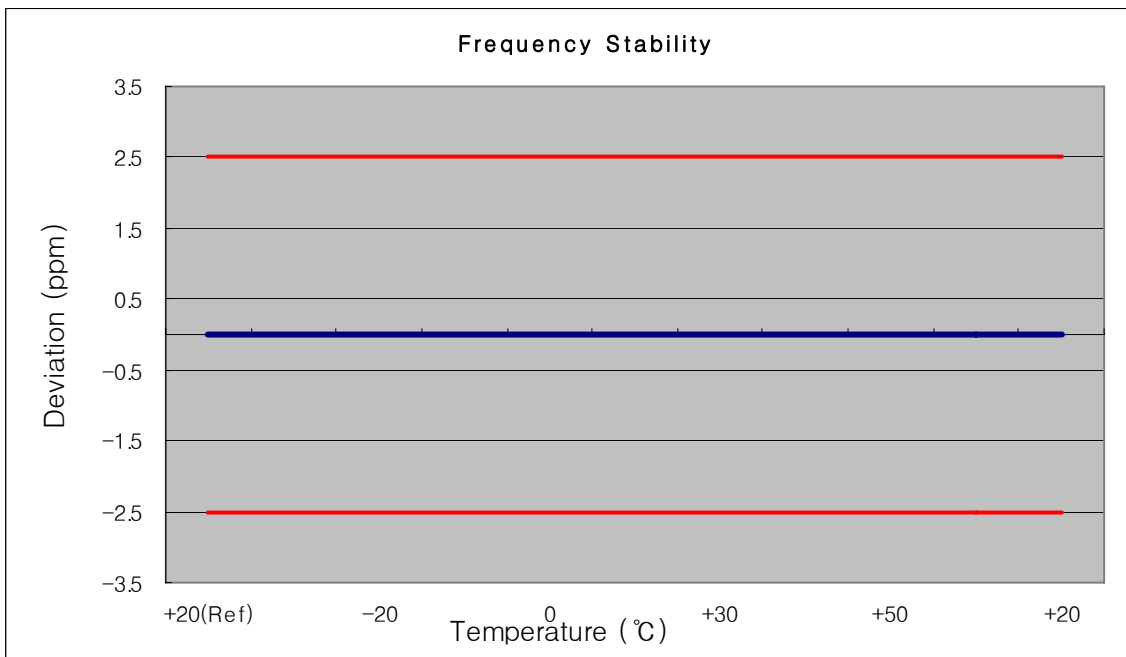



7.5.2 FREQUENCY STABILITY (WiMAX-10 MHz)

OPERATING FREQUENCY: 2593,000,000 Hz
 REFERENCE VOLTAGE: 3.7 VDC
 DEVIATION LIMIT: ± 0.000 25 % or 2.5 ppm

| Voltage (%) | Power (VDC) | Temp. (°C) | Frequency (Hz) | Frequency Error (Hz) | Deviation (%) | ppm |
|----------------|-------------|------------|----------------|----------------------|---------------|--------|
| 100% | 5.0 V | +20(Ref) | 2592 999 997 | 0 | 0.000 000 | 0.000 |
| 100% | | -30 | 2593 000 009 | 8.5 | 0.000 000 | 0.003 |
| 100% | | -20 | 2592 999 997 | -3.3 | 0.000 000 | -0.001 |
| 100% | | -10 | 2593 000 001 | 1.1 | 0.000 000 | 0.000 |
| 100% | | 0 | 2593 000 002 | 1.9 | 0.000 000 | 0.001 |
| 100% | | +10 | 2593 000 008 | 7.6 | 0.000 000 | 0.003 |
| 100% | | +30 | 2593 000 009 | 8.8 | 0.000 000 | 0.003 |
| 100% | | +40 | 2593 000 010 | 9.6 | 0.000 000 | 0.004 |
| 100% | | +50 | 2593 000 013 | 13 | 0.000 001 | 0.005 |
| 115% | 5.75 | +20 | 2593 000 004 | 4.4 | 0.000 000 | 0.002 |
| Batt. Endpoint | 4.25 | +20 | 2593 000 004 | 3.7 | 0.000 000 | 0.001 |

