

SCU User Guide (Draft)

V2.0

Contact and Legal Information

Visit ORBCOMM Online

www.ORBCOMM.com

Contact Support

Website: <https://www.orbcomm.com/en/support>

Email: customer.care@orbcomm.com OR FMSupport@orbcomm.com (Fleet Management support needs)

Phone: (North America Toll-Free) (United Kingdom Toll-Free) +44 800 538.5909

1.800.ORBCOMM

(USA / International Toll)

(United Kingdom Toll) +44 20 3855.6153

+1.804.404.8681

(Australia Toll) +61 (8) 6186 9633

(Austria, Germany, Switzerland Toll) +49

89.208045522

(New Zealand Toll) +64 (9) 884 1439

(Ireland Toll) +353 1.582.4013

Office: 395 W Passaic Street, Suite 325, Rochelle Park, NJ 07662 USA

Export Control Statement

The contents of this document, in whole or in part, shall not be exported from the United States, which export shall include, but not be limited to, transmittal to any non-U.S. citizen wherever said person is located, except in accordance with all United States laws and regulations relating to exports and to all administrative acts of the U.S. Government pursuant to such laws and regulations. Diversion, re-export or transshipment of the contents of this document, in whole or in part, contrary to U.S. law is also strictly prohibited.

Trademark Notice

The ORBCOMM name and the ORBCOMM logo are registered trademarks owned by ORBCOMM LLC or its affiliated companies.

Other trademarks, trade names, and logos are those of their respective owners.

TABLE OF CONTENTS

Contact and Legal Information	2
Contact Support	2
TABLE OF CONTENTS	3
About This User Guide.....	4
Purpose	4
Cautions Concerning Servicing the Device.....	4
WEEE Statement	4
1 Overview.....	5
2 Specifications.....	6
2.1 Temperature.....	6
2.2 Input Power	6
2.3 Pin Connector Assignment	6
2.4 VHF Receiver	7
2.5 VHF Transmitter	7
3 Compliance.....	8
4 Installation.....	9
4.1 Gather the Required Tool and Components	9
4.2 Review the Mounting Guidelines	9
4.3 Install the SCU	11
4.4 Apply Power and Register the SCU.....	12
APPENDIX A Troubleshooting.....	13

About This User Guide

Disclaimer:

This guide contains information about the SCU. No representations or warranties are made as to the accuracy or completeness of the information contained herein. No representations or warranties are made as to the completeness and compliance of any installations that are performed using this guide.

Purpose

This guide contains product information for the SCU. The intended audiences for this guide include field support personnel, product evaluators, and certified third-party personnel. It is particularly intended for personnel who are responsible for system installation and activation. In addition, and as is appropriate, this guide may be used for training purposes.

Cautions Concerning Servicing the Device

CAUTION: The equipment must be turned off when service work is required.

CAUTION: Remove the cable from the negative terminal of the reefer battery and secure the cable to prevent accidental contact before performing any installation or service procedure. Only trained service personnel should perform the procedures outlined in this manual. These procedures may allow exposure to high electrical energy that could result in electric shock and injury to untrained personnel during servicing, maintenance, and installation of the unit.

CAUTION: To avoid personal injury, the battery should be disabled by disconnecting the negative terminal cable prior to installation or servicing.

CAUTION: Be aware of your working environment. Take appropriate steps to ensure that the SCU cable harness and especially its connectors are not exposed to soil, water, or other contaminants that may be present at the installation site.

WEEE Statement

Disposal of this product should be handled according to all national laws and regulations.

The mark shown to the right is in compliance with Waste Electrical and Electronic Equipment Directive 2002/96/EC (WEEE). The mark indicates the requirement NOT to dispose the equipment as unsorted municipal waste but use the return and collection systems according to local law.



1 Overview

The SCU is a smart antenna product manufactured by ORBCOMM. The SCU provides a low cost, versatile satellite connection for customer's tracking and monitoring terminals through the ORBCOMM OGx interface. It is primarily targeted towards the construction equipment market. A single RS-232 port is available to communicate with the SCU. In addition, SCU utilizes a rugged, IP67 enclosure that house all electronics and power control. An external antenna interfaces through an IP67 RF connector providing satellite connections. The SCU is powered externally through the main connector. This guide provides information required for a successful, reliable installation and operation of the SCU on a vehicle, boat or other platform. This guide does not address the SCU commissioning procedures as these procedures are performed by Orbcomm's customer.

Figure 1: SCU



2 Specifications

2.1 Temperature

Parameter	Value
Operating Temperature Range	-40° to +85°C (-40° to +185°F)
Storage Temperature Range	-40° to +85°C (-40° to +185°F)

2.2 Input Power

Parameter	Value
Power Supply Voltage	12 or 24 V DC
Maximum Input Power	36 W (during satellite transmit)

2.3 Pin Connector Assignment

Figure 2: VCE SCU Connector PIN Assignment



Table 1: Pin Descriptions

Pin Position	Signal Name	Comments
1	RS232 Tx	Transmitted by Customer's telematics device, received by SCU
2	RS232 Rx	Received by Customer's telematics device, transmitted by SCU
3	Not Connected	No connection to this pin
4	ENABLE	SCU ON/OFF control from the customer's telematics device
5	PWRGND	Vehicle battery negative terminal
6	PWRBAT	Vehicle battery positive terminal (fused)

2.4 VHF Receiver

Parameter	Value
Frequency Range	137 to 138MHz
Frequency Stability	< 2ppm
Data Rates / Modulation	4800bps Symmetrical-Differential Phase Shift Keying (SDPSK) modulation
Sensitivity	-120 dBm typical
Dynamic Range	-120 to -90 dBm

2.5 VHF Transmitter

Parameter	Value																				
Frequency Range	148.000 to 150.050MHz																				
Frequency Accuracy	< 2 ppm																				
Data Rates / Modulation	2400bps SDPSK modulation																				
Output Power	5 Watts typical																				
Antenna Gain (maximum)	3.0 dBi																				
Power Variance	Maximum ±1dB																				
Tx Duty-Cycle	9 seconds every 15 minutes (?)																				
Spurious Emissions	<table border="0"> <thead> <tr> <th>Frequency Range</th> <th>Limit</th> <th>BW</th> <th></th> </tr> </thead> <tbody> <tr> <td>100 kHz to 1G Hz</td> <td></td> <td></td> <td>-36</td> </tr> <tr> <td>dBm 100 kHz</td> <td></td> <td></td> <td></td> </tr> <tr> <td>1G Hz to 12.75G Hz</td> <td>-30 dBm</td> <td>1 MHz</td> <td></td> </tr> <tr> <td>1559.01 to 1626.50 MHz</td> <td>-40 dBm</td> <td>1 MHz</td> <td></td> </tr> </tbody> </table>	Frequency Range	Limit	BW		100 kHz to 1G Hz			-36	dBm 100 kHz				1G Hz to 12.75G Hz	-30 dBm	1 MHz		1559.01 to 1626.50 MHz	-40 dBm	1 MHz	
Frequency Range	Limit	BW																			
100 kHz to 1G Hz			-36																		
dBm 100 kHz																					
1G Hz to 12.75G Hz	-30 dBm	1 MHz																			
1559.01 to 1626.50 MHz	-40 dBm	1 MHz																			
VSWR	3:1 max																				

3 Compliance

FCC (United States of America) CFR47 PART 15

- FCC ID: xxxxxxxxxxxxxxxxx

FCC Compliance Statement

This device complies with part 15 of the FCC Rules. Operation is subject to the following two conditions: (1) This device may not cause harmful interference, and (2) this device must accept any interference received, including interference that may cause undesired operation.

ISED (Canada) ICES-003

- IC ID: xxxxxxxxxxx

IC Compliance Statement:

This device complies with Industry Canada license-exempt RSS standard(s). Operation is subject to the following two conditions: (1) This device may not cause interference, and (2) this device must accept any interference, including interference that may cause undesired operation of the device. Le présent appareil est conforme aux CNR d'Industrie Canada applicable aux appareils radio exempts de licence. L'exploitation est autorisée aux deux conditions suivantes: (1) l'appareil ne doit pas produire de brouillage, et (2) l'utilisateur de l'appareil doit accepter tout brouillage radioélectrique subi, même si le brouillage est susceptible d'en compromettre le fonctionnement.

CE Mark (Europe) RED 2014/53/EU

- Declaration of Conformity

Hereby, ORBCOMM Inc. declares that the radio equipment types listed in this document comply with Directive 2014/53/EU.

The full text of the EU declaration of conformity is available from <http://www2.orbcomm.com/eudoc>.

RF Exposure & Non-Modification Warning

- RF Exposure Statement

This equipment complies with the radiation exposure limits set forth for an uncontrolled environment. This equipment should be installed and operated with a minimum distance of 20cm between the radiator and any part of the human body.

Non-modification Warning statement Equipment changes or modifications not expressly approved by the party responsible for FCC compliance, could void the user's authority to operate the equipment and could create a hazardous condition.

Cet équipement est conforme aux limites d'expositions aux rayonnements ISDE énoncées pour un environnement non contrôlé. Cet équipement doit être installé et utilisé à une distance supérieure à 20 cm entre l'élément rayonnant et votre corps

Ingress Protection

- IP67

RoHS

- Restriction of Hazardous Substances (RoHS)

4 Installation

IMPORTANT

READ ALL INSTRUCTIONS CAREFULLY BEFORE INSTALLING. FAILURE TO DO SO MAY CAUSE PERSONAL INJURY OR DAMAGE TO PRODUCT AND/OR PROPERTY. •

• Review the product package and contents prior to beginning the installation. Take care when opening the packaging and removing items. If a return is needed you will want to return the product in its original packaging if possible. • This instruction guide is provided as a GENERAL installation guide; some assets vary dimensionally and may require additional steps. • The manufacturer and / or distributors do not accept responsibility for third party charges, labor, and or third part replacement modifications. Some modifications may void the factory warranty. • Exercise due diligence when installing this product. ORBCOMM does not accept any responsibility for asset damage or personal injury resulting from the installation of this product. Careless installation and operation can result in serious injury or equipment damage. • All liability for installation and use rests with the owner / operator. • Always make sure you have a clean, dry, and well-lit work area. • Always ensure products are secure during disassembly and installation. • Always take steps to protect yourself when drilling, cutting, and grinding because this may create flying particles that can cause injury. • Thoroughly inspect the area to be drilled, on both sides of material, prior to modification, and relocate any objects that may become damaged. • Always route electrical cables carefully. Avoid moving parts, parts that may become hot and rough, or sharp edges. • Make sure to fully understand the product, its intended use, and operation prior to use.

CAUTION: The main product label is located on the bottom / underside of the device. This label may not be visible after a bottom mount installation.

4.1 Gather the Required Tool and Components

The following components are available from ORBCOMM:

- A SCU

The following components are customer supplied for an installation:

- customer telematics unit (VTU) cable harness
- customer antenna with antenna cable

Each SCU has a unique serial number, termed a mobile ID, used by ORBCOMM to register it on the OG2 network. This is a 15-digit alphanumeric identifier in the format "NNNNNNNSKYXXXX" The mobile ID is located on the SCU label and on the shipping box.

Record this mobile ID before the SCU is installed. You need it later to activate the SCU on the network.

Note: The SCU may be activated on the network prior to or after shipping based on the customer's agreement.

4.2 Review the Mounting Guidelines

CAUTION: It is very important for installers to install the SCU in a safe and secure way to avoid danger or damage to persons or property.

- Mount the SCU on a flat surface in a protected location within the vehicle cab, within the vehicle's telematics compartment next to the VTU.

Figure 3: SCU Mounting Location

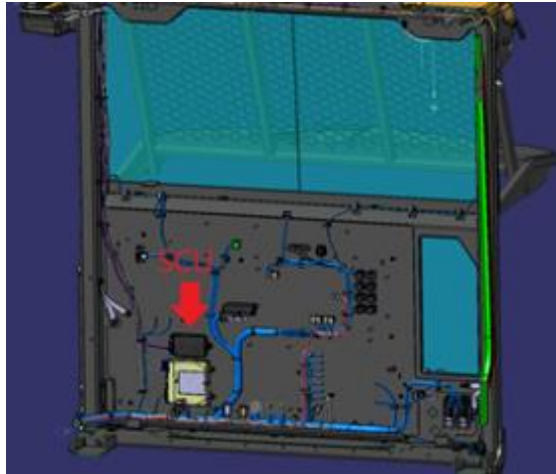

- Mount the SCU on a solid, stable surface that is clean and free of oil, dirt, and debris.
- Fasten the SCU securely so that it is not loose and does not move easily.
- Check that the SCU's cable reaches the VTU before you drill any mounting holes.
- Mount the SCU on a surface that does not get hotter than the maximum operating temperature (+85°C/+185°F). If the surface may get hotter, mount the SCU with a thermal barrier between it and the mounting surface.
- Mount the SCU antenna where it has a clear view of the sky/satellite. For a mobile installation, this means that it is preferable to install at the highest point on the vehicle where it has a clear view of the sky in all directions.

Figure 4: Antenna Mounting Location

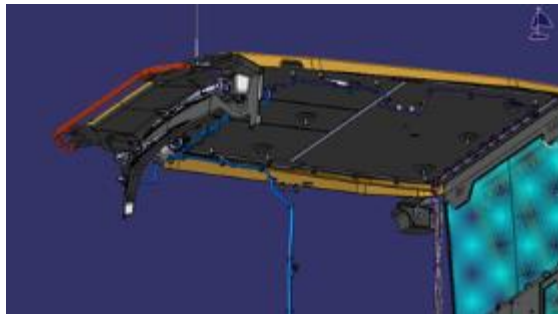

- **DO NOT** mount the SCU close to other electrical equipment due to possible radiated and/or conducted electromagnetic interference.
- **DO NOT** mount the SCU close to radar or other communications antennas. Use the following guidelines:
 - > 1 m from VHF/UHF antenna
 - > 3 m from loop antenna
 - > 4 m from MF/HF antenna
 - > 5 m from other satellite antennas

Not within a radar beam

- **DO NOT** mount the SCU where water may build-up or collect.
- **DO NOT** mount the SCU close to an exhaust pipe due to the excessive heat and the potential for the exhaust pipe causing satellite blockage.
- **DO NOT** mount the SCU close to air horns or any tractor roof hardware (for example, emergency lights) that could interfere with satellite communications.
- **DO NOT** install the V SCU inside a truck under the roof liner.

4.3 Install the SCU

1. Use the enclosure as a template to mark the installation location for the SCU. Ensure that the hole positions are marked.
2. Install three mounting bolts in the mounting location.

Figure 5: Mounting Bolt Locations

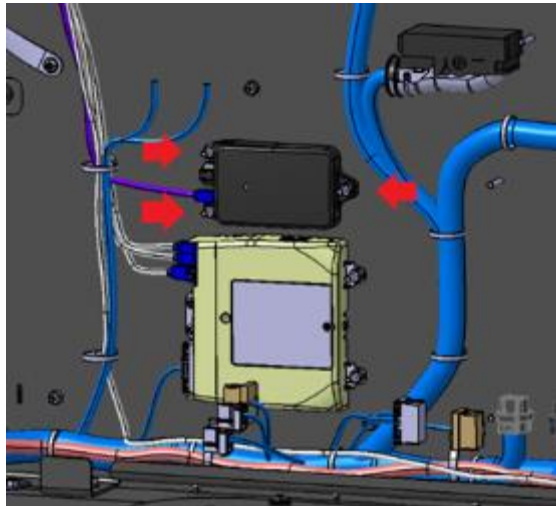

3. Position the SCU on the mounting bolts, and then fix the enclosure to the vehicle with nuts. The fixing bolt size is M6.
4. Torque the fixing bolts to 10 ± 1.5 Nm (M6 Medium torque, Property class 8.8).
5. Connect the SCU to the VTU with the cable harness.
6. Connect the antenna cable to the SCU and route the antenna cable to previously installed antenna.

Figure 6: Antenna Cable Routing

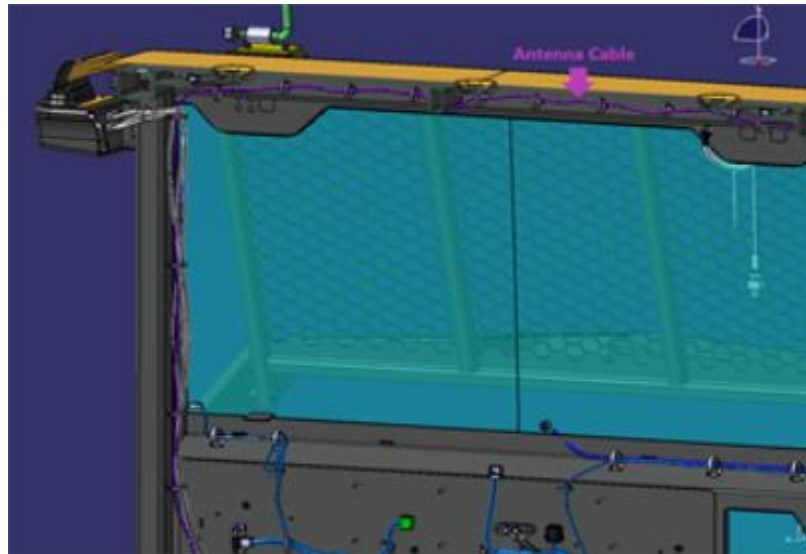

4.4 Apply Power and Register the SCU

When you apply power, the SCU goes into satellite search mode to acquire the OG2 network. This activity may take a few minutes to complete. The SCU must complete registration to operate. Once the SCU synchronizes itself with the network, it sends a registration message to the OG2 network. The SCU will not register until it has a connection to the satellite. The OG2 network records the registration message and forwards the registration message to the user's application. The OG2 network sends an acknowledgment message over the satellite to the SCU. The SCU is now available to send and receive messages via satellite.

APPENDIX A Troubleshooting

The following section contains troubleshooting information.

Situation : SCU Does Not Register or Report

On application of external power, the SCU should register with the satellite and send a report.

Note: The SCU must be visible to the satellite to register with the network and registration normally takes a few minutes.

If the SCU fails to register or report:

- Ensure that the SCU has a clear line-of-sight to the satellite. The SCU must operate outdoors and be unobstructed by buildings, forest canopy, and rock cuts.
- Check that no objects or debris are touching the SCU antenna and blocking transmission.
- Verify with your supplier that the SCU is assigned to your account and registered (that it is sending and receiving) and that the OG2 network is operating properly.

Replace the SCU if the earlier checks fail to uncover the problem.