

A

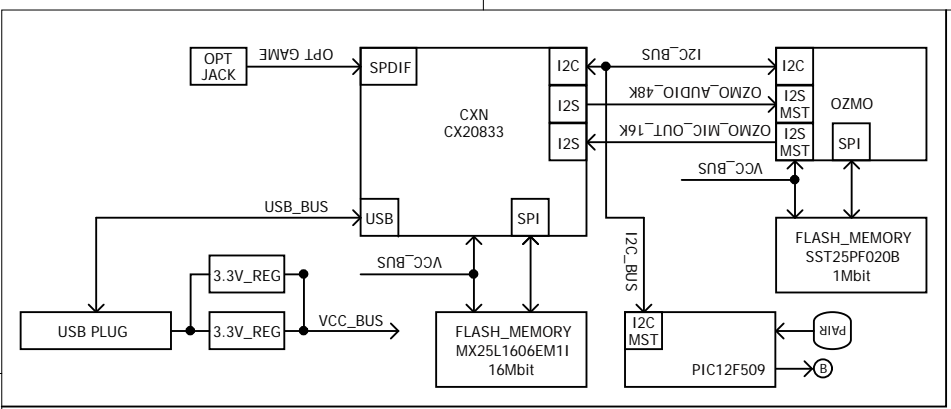

Designator's Convention:
 100: MCU
 200: CXN
 300: Audio Circuitry
 400: Left Channel
 500: Mic Channel
 600: Right Channel
 700: OZMO
 800: UI
 900: Power Supply

REVISIONS			
REV	DESCRIPTIONS	DATE	APPROVED
0.1	Created.	2016-11-28	S.Garzon
0.1	Change R200 and R212 from 39R0 to 0R00.	2016-12-13	S.Garzon
0.1	Change SW800 for side tact switch.	2016-12-16	S.Garzon
0.1	Added single GPIO LED and Button circuitry.	2016-12-19	S.Garzon
0.1	Added one LDO instead of two switchers.	2017-01-16	S.Garzon
0.1	Added D900.	2017-01-23	S.Garzon
0.2	Make U100, R104, R105, R809, C102 = 0R00 Make R800 = 0R00	2017-03-30	D. Zepp
0.2	Changed C100, value and location, Repurpose TP24, TP25	2017-03-30	D. Zepp
0.2	Changed values, C200, C203, C258, C260	2017-03-30	D. Zepp
0.2	Changed D204, D205, D800, D900	2017-04-01	D. Zepp

B

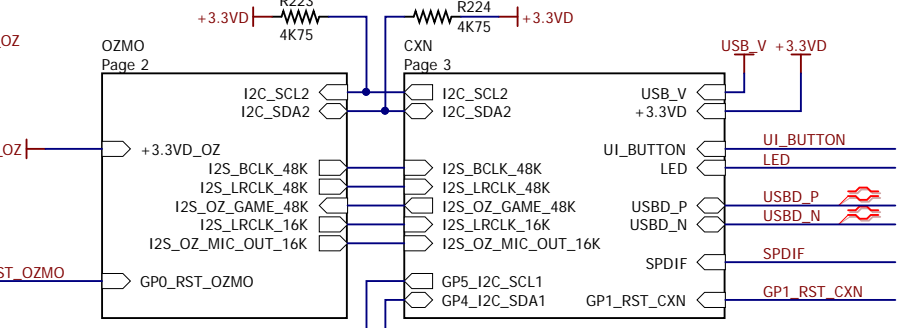
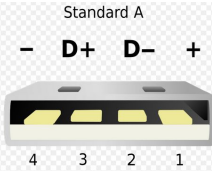
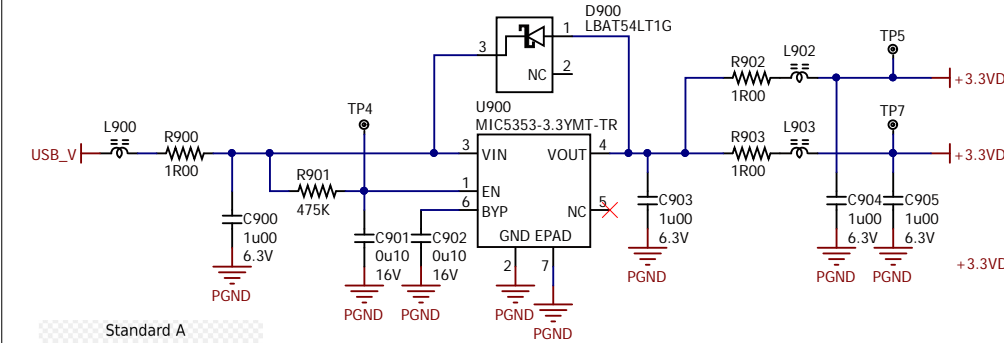

C

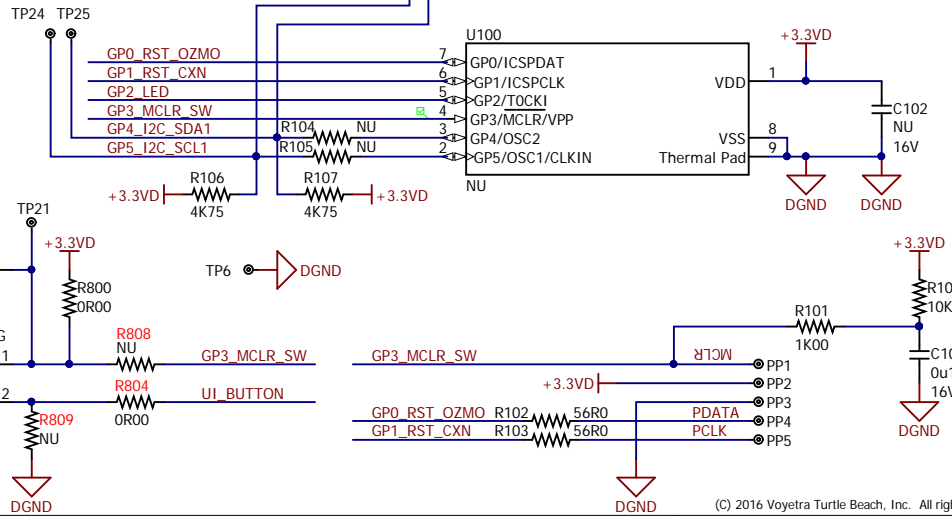
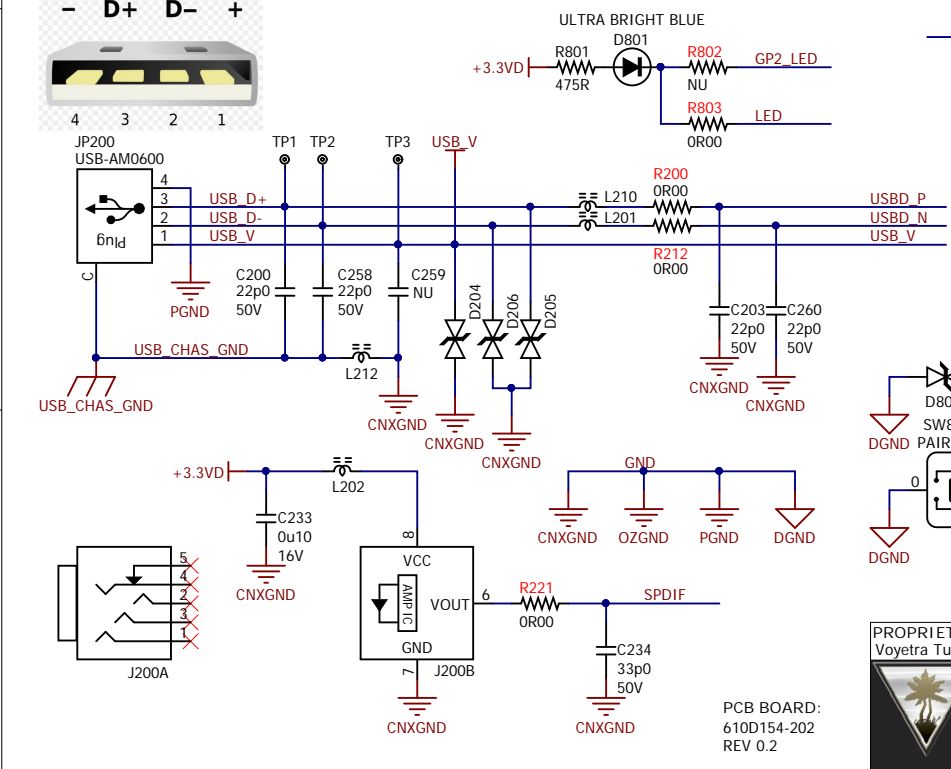

D

PROPRIETARY STATEMENT: This material, including all text, images and information, is the property of Voyetra Turtle Beach, Inc. and subject to copyright and other intellectual property laws.

(C) 2016 Voyetra Turtle Beach, Inc. All rights Reserved.

Voyetra Turtle Beach, Inc.
 100 Summit Lake Drive, Suite 100 Valhalla, NY 10595.

PROJECT:	RAPTOR TX	TITLE:	MAIN BOARD
DRAWN:	S.Garzon	DATE:	2016-11-28
CHECKED:	S.Garzon	DATE:	2017-01-23
APPROVED:		DATE:	2017-03-30
SIZE Letter		DWG NO:	600D154-202
REV:		0.2	
SHEET 1 OF 3		CONFIDENTIAL	

REVISIONS			
REV	DESCRIPTIONS	DATE	APPROVED
0.1	Created.	2016-11-28	S.Garzon
0.1	No changes on this page.	2016-12-19	S.Garzon
0.2	Fixed Reset for OZMO, Changed test point to header for OZMO	2017-3-30	D. Zepp
0.2	Changed C726, C730 to NU, Changed C727, R704, C718	2017-3-30	D. Zepp
0.2	TP26, TP28 used for LP testing	2017-3-30	D. Zepp

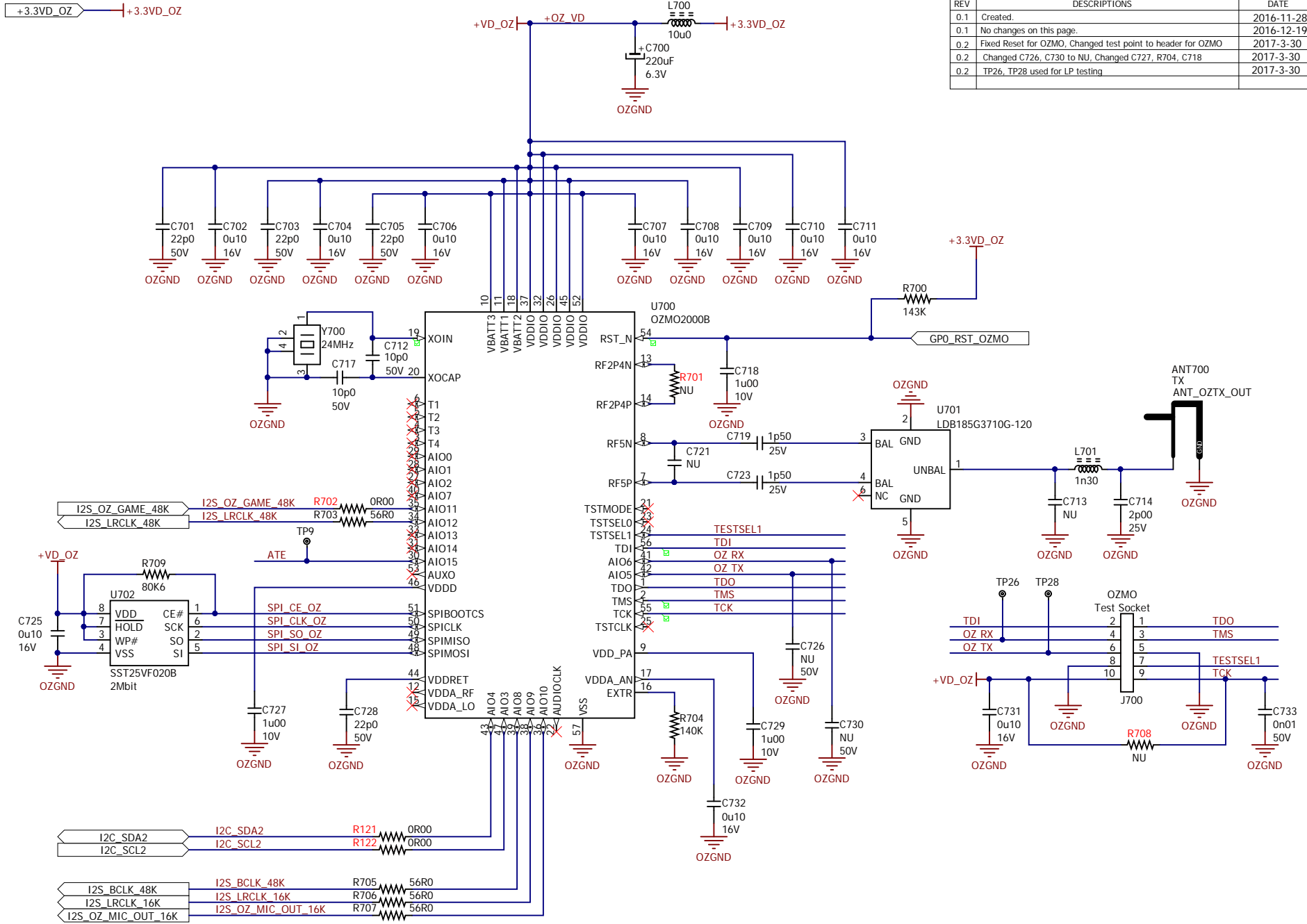

PROPRIETARY STATEMENT: This material, including all text, images and information, is the property of Voyetra Turtle Beach, Inc. and subject to copyright and other intellectual property laws.

(C) 2016 Voyetra Turtle Beach, Inc. All rights Reserved.

PROJECT: RAPTOR TX		TITLE: Main Board OZMO	
DRAWN: S.Garzon	DATE: 2016-11-28	SIZE Letter	DWG NO: 600D154-202
CHECKED: S.Garzon	DATE: 2016-12-19	DATE: 2016-3-30	REV: 0.2
APPROVED:	DATE:	DATE: 2016-3-30	CONFIDENTIAL SHEET 2 OF 3



REVISIONS			
REV	DESCRIPTIONS	DATE	APPROVED
0.1	Created.	2016-11-28	S.Garzon
0.1	Changed C228 from 0.1uF to 10uF. Added R225 to tie CNDS. Updated L200 PM. Updated CX symbol updated Pin 52 and 53 location. Change R222 from 80K6 to 4K75	2016-12-14	S.Garzon
0.1	Added R226 and R227 as pull up. Added components for CNX reset.	2016-12-14	S.Garzon
0.1	Removed R225, not needed.	2016-12-19	S.Garzon
0.2	Added single GPIO LED and Button circuitry.	2017-3-30	D.Zepp
0.2	Moved C100 to this page and Changed Value	2017-4-01	D.Zepp
0.2	Changed D802, D803, O800		

- SPI_CE_CXN ● TP17
- SPI_CLK_CXN ● TP18
- SPI_SO_CXN ● TP19
- SPI_SI_CXN ● TP20

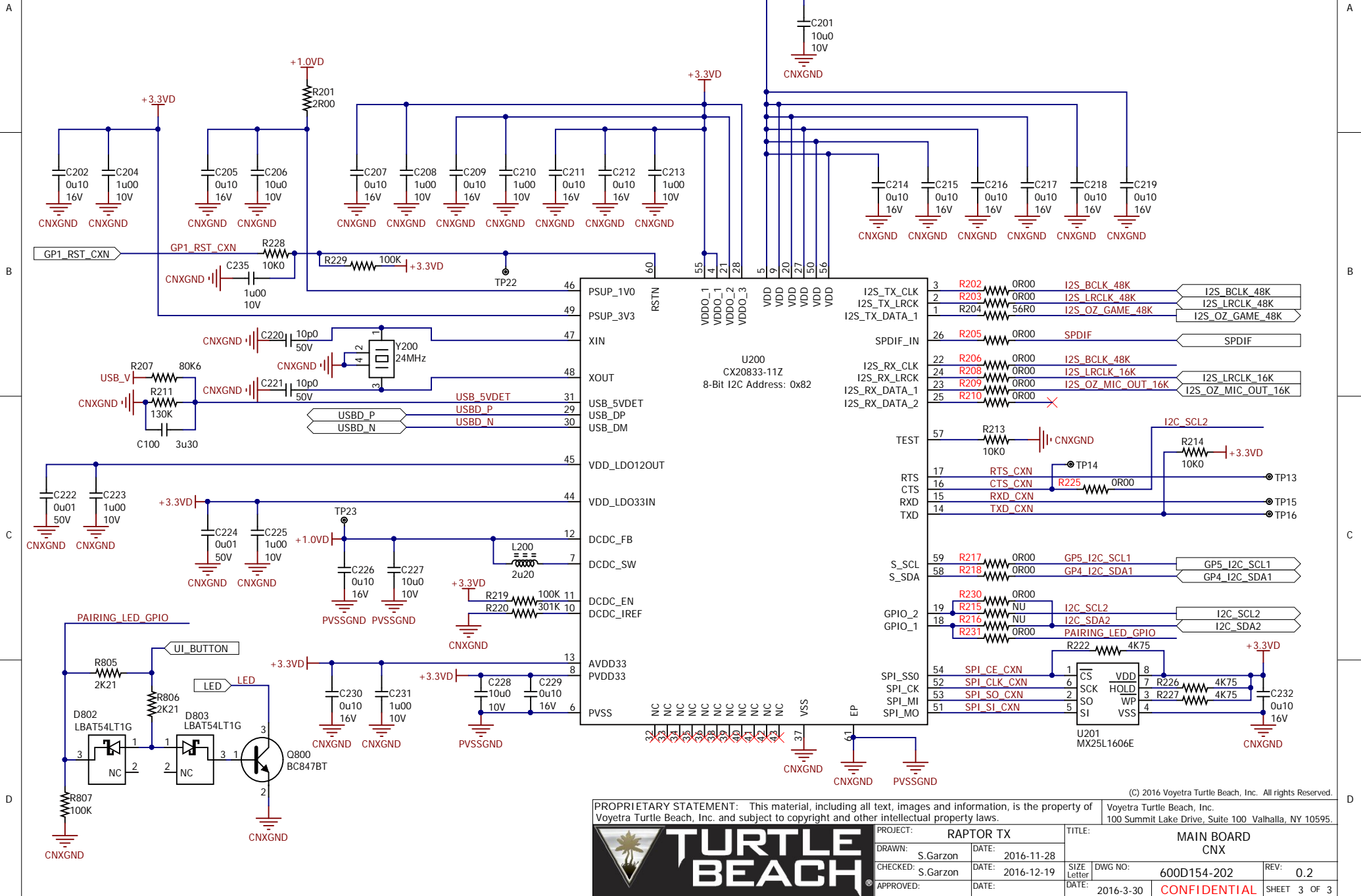

PROPRIETARY STATEMENT: This material, including all text, images and information, is the property of Voyetra Turtle Beach, Inc. and subject to copyright and other intellectual property laws.



PROJECT:	RAPTOR TX	TITLE:	MAIN BOARD CNX
DRAWN:	S.Garzon	DATE:	2016-11-28
CHECKED:	S.Garzon	DATE:	2016-12-19
APPROVED:		DATE:	2016-3-30
SIZE Letter		DWG NO:	600D154-202
REV: 0.2		CONFIDENTIAL SHEET 3 OF 3	