

Emissions Test Report

EUT Name: USB Wireless Audio Transmitter

Model No.: Ear Force Stealth 600P TX

CFR 47 Part 15.247: 2017 and RSS 247 Issue 2, 2017

Prepared for:

Voyetra Turtle Beach, Inc.
100 Summit Lake Drive, Suite 100
Valhalla, New York 10595 USA

Prepared by:

TUV Rheinland of North America, Inc.
1279 Quarry Lane
Pleasanton, CA 94566
Tel: (925) 249-9123
Fax: (925) 249-9124
<http://www.tuv.com/>

Report/Issue Date: June 1, 2017
Revision Number 0
Project Number: 0000148609
Report Number: 31761757.001

Revisions

Revision No.	Date MM/DD/YYYY	Reason for Change	Author
0	06/01/2017	Original Document	N/A

Note: Latest revision report will replace all previous reports.

Statement of Compliance

Manufacturer: Voyetra Turtle Beach, Inc.
100 Summit Lake Drive, Suite 100
Valhalla, New York 10595 USA

Requester / Applicant: Tim Blaney
(530) 277-3482

Name of Equipment: USB Wireless Audio Transmitter
Model No. Ear Force Stealth 600P TX (TB300-3341-01)

Type of Equipment: Intentional Radiator

Application of Regulations: CFR 47 Part 15.247: 2017 and RSS 247 Issue 2, 2017

Test Dates: May 2, 2017 to May 10, 2017

Guidance Documents:

Emissions: ANSI C63.10-2013, KDB 558074 D01 DTS Measurement Guidance v04

Test Methods:

Emissions: ANSI C63.10-2013, KDB 558074 D01 DTS Measurement Guidance v04

The electromagnetic compatibility test and documented data described in this report has been performed and recorded by TUV Rheinland, in accordance with the standards and procedures listed herein. As the responsible authorized agent of the EMC laboratory, I hereby declare that the equipment described above has been shown to be compliant with the EMC requirements of the stated regulations and standards based on these results. If any special accessories and/or modifications were required for compliance, they are listed in the Executive Summary of this report.

This report must not be used to claim product endorsement by A2LA or any agency of the U.S. Government. This report contains data that are not covered by A2LA accreditation. This report shall not be reproduced except in full, without the written authorization of TUV Rheinland of North America.

Jeremy Luong

Test Engineer

Date June 1, 2017

David Spencer

Laboratory Signatory

Date June 1, 2017



Industry
Canada

Industrie
Canada

Testing Cert #3331.02

US1131

2932M-1

Table of Contents

1	Executive Summary	7
1.1	Scope	7
1.2	Purpose	7
1.3	Summary of Test Results	8
1.4	Special Accessories	8
1.5	Equipment Modifications	8
2	Laboratory Information	9
2.1	Accreditations & Endorsements	9
2.1.1	US Federal Communications Commission	9
2.1.2	NIST/ A2LA	9
2.1.3	Canada – Industry Canada	9
2.1.4	Japan – VCCI	9
2.1.5	Acceptance by Mutual Recognition Arrangement	10
2.2	Test Facilities	10
2.2.1	Emission Test Facility	10
2.2.2	Immunity Test Facility	10
2.3	Measurement Uncertainty	10
2.3.1	Sample Calculation – radiated & conducted emissions	11
2.3.2	Measurement Uncertainty	11
2.3.3	Measurement Uncertainty Immunity	12
2.4	Calibration Traceability	12
3	Product Information	13
3.1	Product Description	13
3.2	Equipment Configuration	13
3.3	Operating Mode	13
3.4	Unique Antenna Connector	14
3.4.1	Results	14
4	Emissions	16
4.1	Output Power Requirements	16
4.1.1	Test Method	16
4.1.2	Results	17
4.2	Occupied Bandwidth	20
4.2.1	Test Method	20
4.2.2	Results	20
4.3	Peak Power Spectral Density	25
4.3.1	Test Method	25
4.3.2	Results	25
4.4	Out of Band Emissions	29
4.4.1	Test Method	29
4.4.2	Results	30

Table of Contents

4.5	Maximum Permissible Exposure	34
4.5.1	Test Methodology	34
4.5.2	FCC KDB 447498 D01 – General SAR Test Exclusion Guidance	34
4.5.3	EUT Operating Condition	35
4.5.4	Classification	35
4.5.5	SAR Test Exclusion Threshold	35
4.6	Transmit Spurious Emissions	36
4.6.1	Test Methodology	36
4.6.2	Transmitter Spurious Emission Limit	37
4.6.3	Test Results	37
4.6.4	Sample Calculation	49
4.7	AC Conducted Emissions	50
4.7.1	Test Methodology	50
4.7.2	Test Results	50
5	Test Equipment List	55
5.1	Equipment List	55
6	EMC Test Plan	56
6.1	Introduction	56
6.2	Customer	56
6.3	Equipment Under Test (EUT)	57
6.4	Test Specifications	60

Index of Tables

Table 1: Summary of Test Results	8
Table 2: RF Output Power at the Antenna Port – Test Results	16
Table 3: Occupied Bandwidth – Test Results.....	20
Table 4: Peak Power Spectral Density – Test Results	25
Table 5: Out of Band Emissions – Test Results.....	29
Table 6: Transmit Spurious Emission at Band-Edge Requirements.....	37
Table 7: Customer Information	51
Table 8: Technical Contact Information.....	51
Table 9: EUT Specifications	52
Table 10: Interface Specifications	53
Table 11: Supported Equipment.....	53
Table 12: Description of Sample used for Testing.....	53
Table 13: Description of Test Configuration used for Radiated Measurement.....	53
Table 14: Final Test Mode for 2403.35 MHz to 2477.35MHz Band	54
Table 15: Test Specifications	55

1 Executive Summary

1.1 Scope

This report is intended to document the status of conformance with the requirements of the CFR 47 Part 15.247: 2017 and RSS 247 Issue 2, 2017 based on the results of testing performed on May 3, 2017 to May 10, 2017 on the USB Wireless Audio Transmitter Model Ear Force Stealth 600P TX manufactured by Voyetra Turtle Beach, Inc. This report only applies to the specific samples tested under the stated test conditions. It is the responsibility of the manufacturer to assure that additional production units of this model are manufactured with identical or EMI equivalent electrical and mechanical components. This report is further intended to document changes and modifications to the EUT throughout its life cycle. All documentation will be included as a supplement.

1.2 Purpose

Testing was performed to evaluate the EMC performance of the EUT in accordance with the applicable requirements, procedures, and criteria defined in the application of regulations and application of standards listed in this report. The 2403.35 MHz to 2477.35 MHz frequency band is covered in this document.

1.3 Summary of Test Results

Table 1: Summary of Test Results

Test	Test Method ANSI C63.4	Test Parameters	Measured Value	Result
Spurious Emission in Transmitted Mode	CFR47 15.209, CFR47 15.247 (d) RSS-GEN Sect.8.9, RSS 247 Sect. 6.2.1.2	Class B	-5.16 dB (Margin)	Complied
Restricted Bands of Operation	CFR47 15.205, RSS GEN Sect.8.10	Class B		Complied
AC Power Conducted Emission	CFR47 15.207, RSS-GEN Sect.8.8	Class B	-9.45 dB (Margin)	Complied
Occupied Bandwidth	CFR47 15.247 (a1), RSS GEN Sect.6.6	≥ 500 kHz	1.573 MHz (DTS) 1.917 MHz (99%)	Complied
Maximum Output Power	CFR47 15.247 (b), RSS 247 Sect. 5.4.4, 6.2.4.1	30 dBm w/ 6 dBi antenna	+1.47 dBm	Complied
Peak Power Spectral Density	CFR47 15.247 (e), RSS 247 Sect. 5.2.2	8 dBm/ 3 kHz	-23.86 dBm	Complied
Out of Band Emission	CFR47 15.247 (d), RSS 247 Sect.5.5	-30 dB	-18.87 dB (Margin)	Complied
RF Exposure	CFR47 15.247 (i), 2.1093 RSS-102 Issue 5	General Population	Excluded	Complied

Note: Since EUT is a portable device where the end user will have the direct contact as head wear device, RF Exposure/SAR requirements are calculated for human head and body, and EUT met FCC KDB 447498 SAR exclusion. See Section 4.5 of this report.

1.4 Special Accessories

No special accessories were necessary in order to achieve compliance.

1.5 Equipment Modifications

None

2 Laboratory Information

2.1 Accreditations & Endorsements

2.1.1 US Federal Communications Commission



TUV Rheinland of North America at 1279 Quarry Ln, Pleasanton, CA 94566 is recognized by the commission for performing testing services for the general public on a fee basis. These laboratory test facilities have been fully described in reports submitted to and accepted by the FCC (US1131). The laboratory scope of accreditation includes: Title 47 CFR Parts 15, 18, and 90. The accreditation is updated every 3 years.

2.1.2 NIST / A2LA



TUV Rheinland of North America is accredited by the National Voluntary Laboratory Accreditation Program, which is administered under the auspices of the National Institute of Standards and Technology. The laboratory has been assessed and accredited in accordance with ISO Guide 17025:1999 and ISO 9002 (Lab Code Testing Cert #3331.02). The scope of laboratory accreditation includes emission and immunity testing. The accreditation is updated annually.

2.1.3 Canada – Industry Canada



TUV Rheinland of North America at the 1279 Quarry Ln, Pleasanton, CA 94566 address is accredited by Industry Canada for performing testing services for the general public on a fee basis. This laboratory test facilities have been fully described in reports submitted to and accepted by Industry Canada (File Number 2932M). This reference number is the indication to the Industry Canada Certification Officers that the site meets the requirements of RSS 212, Issue 1 (Provisional). The accreditation is updated every 3 years.

2.1.4 Japan – VCCI



The Voluntary Control Council for Interference by Information Technology Equipment (VCCI) is a group that consists of Information Technology Equipment (ITE) manufacturers and EMC test laboratories. The purpose of the Council is to take voluntary control measures against electromagnetic interference from Information Technology Equipment, and thereby contribute to the development of a socially beneficial and responsible state of affairs in the realm of Information Technology Equipment in Japan. TUV Rheinland of North America at 1279 Quarry Ln, Pleasanton, CA 94566 has been assessed and approved in accordance with the Regulations for Voluntary Control Measures.

VCCI Registration No. for Pleasanton: A-0261

2.1.5 Acceptance by Mutual Recognition Arrangement



The United States has an established agreement with specific countries under the Asia Pacific Laboratory Accreditation Corporation (APLAC) Mutual Recognition Arrangement. Under this agreement, all TUV Rheinland at 1279 Quarry Ln, Pleasanton, CA 94566 test results and test reports within the scope of the laboratory NIST / A2LA accreditation will be accepted by each member

country.

2.2 Test Facilities

All of the test facilities are located at 1279 Quarry Lane, Pleasanton, California 94566, USA.

2.2.1 Emission Test Facility

The Semi-Anechoic chamber and AC Line Conducted measurement facility used to collect the radiated and conducted data has been constructed in accordance with ANSI C63.7:1992. The site has been measured in accordance with and verified to comply with the theoretical normalized site attenuation requirements of ANSI C63.4-2014, at a test distance of 3 and 5 meters. The site is listed with the FCC and accredited by A2LA (Lab Code Testing Cert #3331.02). The 3/5-meter semi-anechoic chamber used to collect the radiated data has been verified to comply with the theoretical normalized site attenuation requirements of ANSI C63.4-2014, at a test distance of 3 meter and 5 meters. A report detailing this site can be obtained from TUV Rheinland of North America.

2.2.2 Immunity Test Facility

ESD, EFT, Surge, PQF: These tests are performed in an environmentally controlled room with a 3.7 m x 4.8 m x 3.175 mm thick aluminum floor connected to PE ground.

For ESD testing, tabletop equipment is placed on an insulated mat with a surface resistivity of 10^9 Ohms/square on a 1.6 m x 0.8 m x 0.8 m high non-conductive table with a 3.175 mm aluminum top (Horizontal Coupling Plane). The HCP is connected to the main ground plane via a low impedance ground strap through two 470-k Ω resistors. The Vertical Coupling Plane consists of an aluminum plate 50 cm x 50 cm x 3.175 mm thick. The VCP is connected to the main ground plane via a low impedance ground strap through two 470-k Ω resistors.

For EFT, Surge, PQF, the HCP and VCP are removed.

RF Field Immunity testing is performed in a 7.3m x 4.3m x 4.1m anechoic chamber.

RF Conducted and Magnetic Field Immunity testing is performed on a 4.8m x 3.7m x 3.175mm thick aluminum ground plane.

All test areas allow a minimum distance of 1 meter from the EUT to walls or conducting objects.

2.3 Measurement Uncertainty

Two types of measurement uncertainty are expressed in this report, per *ISO Guide To The Expression Of Uncertainty In Measurement*, 1st Edition, 1995.

The *Combined Standard Uncertainty* is the standard uncertainty of the result of a measurement when that result is obtained from the values of a number of other quantities; it is equal to the positive square root of the sum of the variances or co-variances of these other quantities, weighted according to how the measurement result varies with changes in these quantities. The term *standard uncertainty* is the result of a measurement expressed as a standard deviation.

2.3.1 Sample Calculation – radiated & conducted emissions

The field strength is calculated by subtracting the Amplifier Gain and adding the Cable Loss and Antenna Correction Factor to the measured reading. The basic equation is as follows:

$$\text{Field Strength (dB}\mu\text{V/m)} = \text{RAW} - \text{AMP} + \text{CBL} + \text{ACF}$$

Where: RAW = Measured level before correction (dBμV)

AMP = Amplifier Gain (dB)

CBL = Cable Loss (dB)

ACF = Antenna Correction Factor (dB/m)

$$\mu\text{V/m} = 10^{\frac{\text{dB}\mu\text{V/m}}{20}}$$

Sample radiated emissions calculation @ 30 MHz

Measurement +Antenna Factor–Amplifier Gain+Cable loss=Radiated Emissions (dBuV/m)

$$25 \text{ dBuV/m} + 17.5 \text{ dB} - 20 \text{ dB} + 1.0 \text{ dB} = 23.5 \text{ dBuV/m}$$

2.3.2 Measurement Uncertainty

Per CISPR 16-4-2	U _{lab}	U _{cispr}
Radiated Disturbance @ 10 meters		
30 – 1,000 MHz	2.25 dB	4.51 dB
Radiated Disturbance @ 3 meters		
30 – 1,000 MHz	2.26 dB	4.52 dB
1 – 6 GHz	2.12 dB	4.25 dB
6 – 18 GHz	2.47 dB	4.93 dB
Conducted Disturbance @ Mains Terminals		
150 kHz – 30 MHz	1.09 dB	2.18 dB
Disturbance Power		
30 MHz – 300 MHz	3.92 dB	4.3 dB

Voltech PM6000A

The estimated combined standard uncertainty for harmonic current and flicker measurements is $\pm 5.0\%$.	Per CISPR 16-4-2 Methods
--	--------------------------

2.3.3 Measurement Uncertainty Immunity

The estimated combined standard uncertainty for ESD immunity measurements is $\pm 8.2\%$.	Per IEC 61000-4-2
The estimated combined standard uncertainty for radiated immunity measurements is ± 4.10 dB.	Per IEC 61000-4-3
The estimated combined standard uncertainty for conducted immunity measurements with CDN is ± 3.66 dB	Per IEC 61000-4-6
The estimated combined standard uncertainty for power frequency magnetic field immunity is $\pm 2.9\%$.	Per IEC 61000-4-8

Thermo KeyTek EMC Pro

The estimated combined standard uncertainty for EFT fast transient immunity measurements is $\pm 2.6\%$.
The estimated combined standard uncertainty for surge immunity measurements is $\pm 2.6\%$.
The estimated combined standard uncertainty for voltage variation and interruption measurements is $\pm 1.74\%$.

The expanded uncertainty at a level of 95% confidence is obtained by multiplying the combined standard uncertainty by a coverage factor of 2. Compliance criteria are not based on measurement uncertainty.

2.4 Calibration Traceability

All measurement instrumentation is traceable to the National Institute of Standards and Technology (NIST). Measurement method complies with ANSI/NCSL Z540-1-1994 and ISO Standard 17025:2005. Equipment calibration records are kept on file at the test facility.

3 Product Information

3.1 Product Description

The Ear Force Stealth 600P Wireless Gaming System consists of two main communication modules, the Stealth 600P RX (“Headset”) and the Stealth 600P TX (“Transmitter”). These two modules comprise a closed-loop wireless audio gaming system that utilize a proprietary 2.4 GHz communication technology to offer wireless streaming audio and chat/talkback capabilities.

3.2 Equipment Configuration

A description of the equipment configuration is given in the Test Plan Section. The EUT was tested as called for in the test standard and was configured and operated in a manner consistent with its intended use. The EUT was connected to rated power and allowed to reach intended operating conditions. The placement of the EUT system components was guided by the test standard and selected to represent typical installation conditions.

In the case of an EUT that can operate in more than one configuration, preliminary testing was performed to determine the configuration that produced maximum radiation.

The final configuration was selected to produce the worst case radiation for emissions testing and to place the EUT in the most susceptible state for immunity testing.

3.3 Operating Mode

A description of the operation mode is given in the Test Plan Section. In the case of an EUT that can operate in more than one state, preliminary testing was performed to determine the operating mode that produced maximum radiation.

The final operating mode was selected to produce the worst case radiation for emissions testing and to place the EUT in the most susceptible state for immunity testing.

3.4 Unique Antenna Connector

An intentional radiator shall be designed to ensure that no antenna other than that furnished by the responsible party shall be used with the device. The use of a permanently attached antenna or of an antenna that uses a unique coupling to the intentional radiator shall be considered sufficient to comply with the provisions of this Section. The manufacturer may design the unit so that a broken antenna can be replaced by the user, but the use of a standard antenna jack or electrical connector is prohibited. This requirement does not apply to carrier current devices or to devices operated under the provisions of CFR47 Parts 15.211, 15.213, 15.217, 15.219, or 15.221.

3.4.1 Results

The Ear Force Stealth 600P TX uses the permanently attached PCB trace antennas inside the device. See EUT Photo for details.

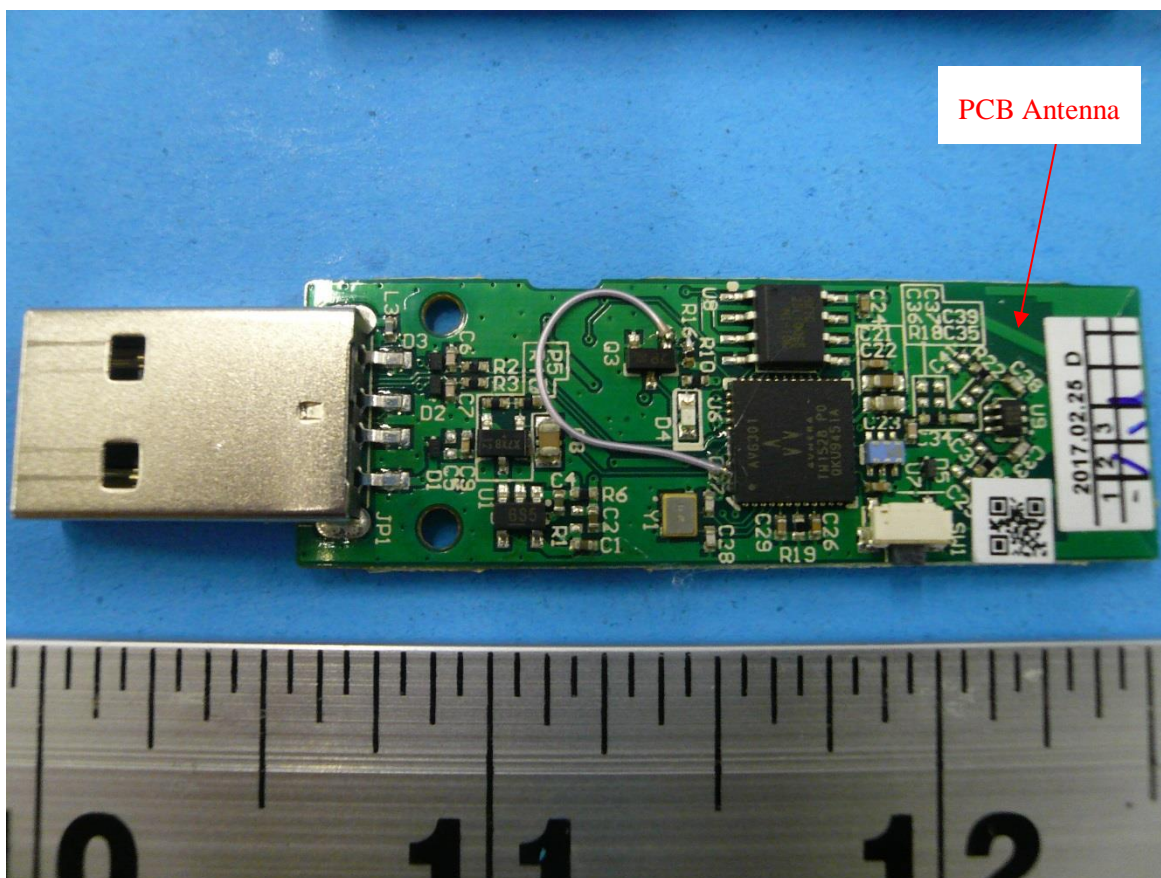

3.5 Duty Cycle

The Ear Force Stealth 600P TX, SN: PP1 was measured.

3.5.1 Results

Mode	On Time (ms)	Period (ms)	Duty Cycle (%)	Duty Factor (dB)
Standard	100	0	100	0

Notes: EUT configured and measured for the duty cycle. All measurements use 100% duty cycle.

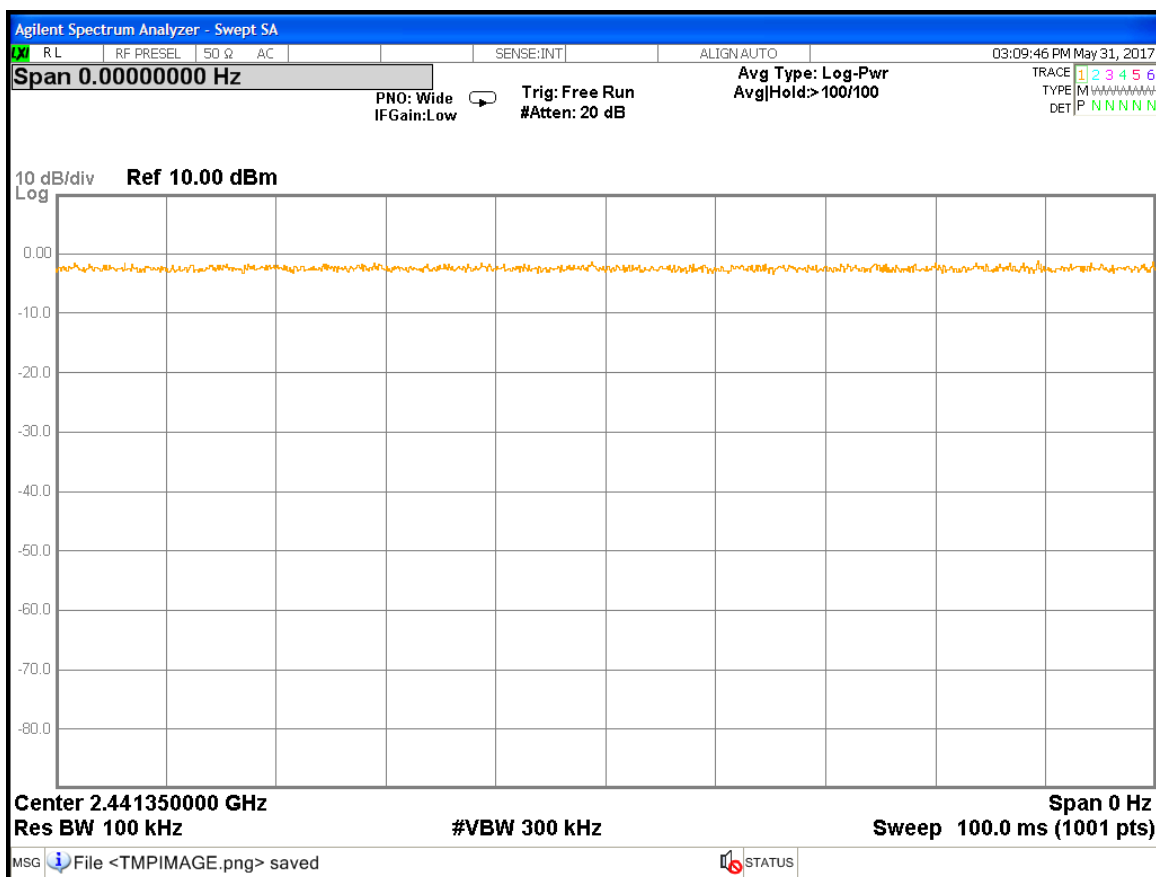

Figure 1: Duty Cycle

4 Emissions

Testing was performed in accordance with CFR 47 Part 15.247: 2017 and RSS 247 Issue 2, 2017. These test methods are listed under the laboratory's A2LA Scope of Accreditation. This test measures the levels emanating from the EUT, thus evaluating the potential for the EUT to cause radio frequency interference to other electronic devices. Procedures described in section 8 of the standard were used.

4.1 Output Power Requirements

The maximum output power requirement is the maximum equivalent isotropic radiated power delivering at the transmitting antenna under specified conditions of measurements in the presence of modulation.

The maximum output power and harmonics shall not exceed CFR47 Part 15.247 (b):2015 and RSS 247: 2017 Sect. 5.4.4, and Sect. 6.2.4.

The maximum transmitted powers are

Band 2400-2483.5 MHz: 1 W

4.1.1 Test Method

The ANSI C63.10-2013 Section 11.9.2.2.2. conducted method was used to measure the channel power output. The preliminary investigation was performed at different data rate/ chain to determine the highest power output for each mode. The worst findings were conducted on 3 channels in each operating range per CFR47 Part 15.247(b): 2017 and RSS 247 Sect. 5.4.4. This test was conducted on 3 channels of Sample, S/N PP #1. The worst mode result indicated below.

Test Setup:

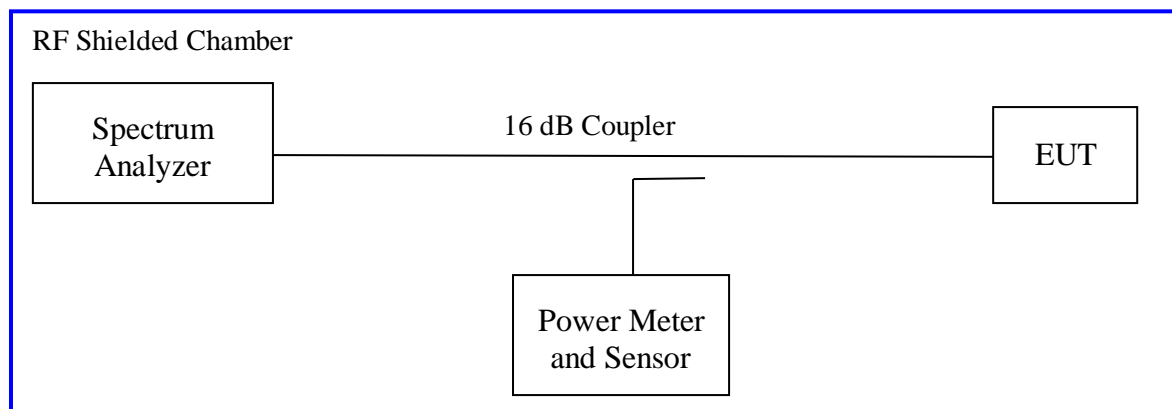

Method AVGSA-1 of "KDB 558074 – DTS Measurement Guidance v04" applies since the EUT continuously transmits with duty cycle greater than 98%. Sample detector was used.

4.1.2 Results

As originally tested, the EUT was found to be compliant to the requirements of the test standard(s).

Table 2: RF Output Power at the Antenna Port – Test Results

Test Conditions: Conducted Measurement		Date: May 2, 2017			
Antenna Type: Integrated		Power Setting: 0 dBm			
Antenna Gain: -0.5 dBi		Signal State: Modulated at 100%			
Ambient Temp.: 23 °C		Relative Humidity: 33%			
USB Wireless Audio Transmitter					
Frequenc y (MHz)	Limit [dBm]	Output [dBm]	Duty Cycle [dB]	∑ Power [dBm]	Margin [dB]
2403.35	+30.00	1.47			-28.53
2441.35	+30.00	1.25			-28.75
2477.35	+30.00	0.55			-29.45
Note: The headset transmitted at 100% duty cycle.					

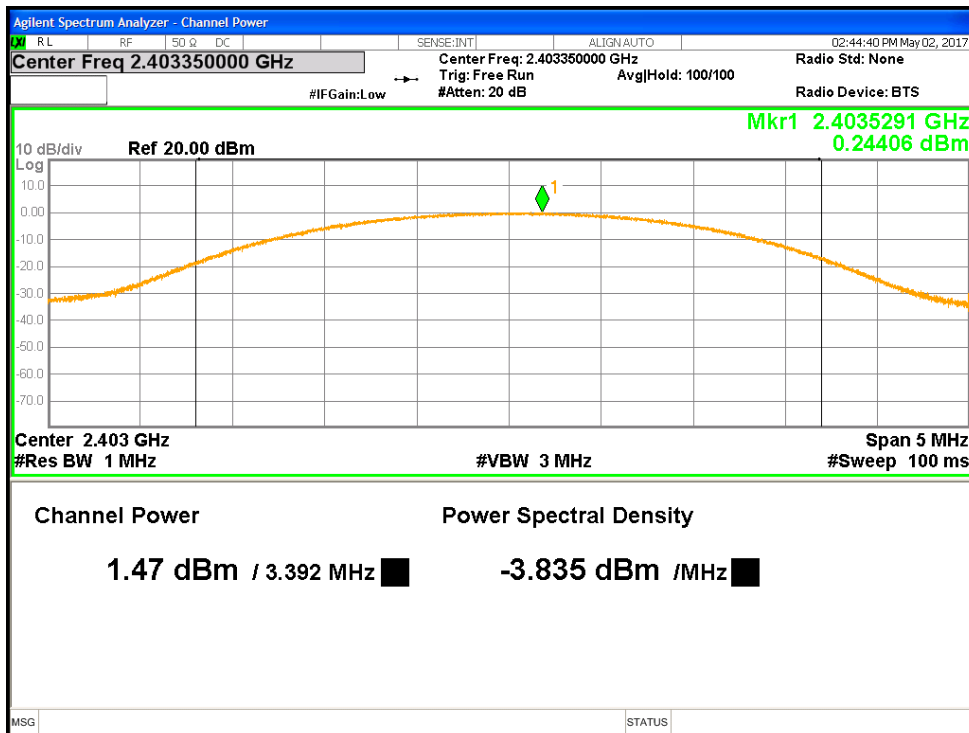

Figure 2: Maximum Transmitted Power, 2403.35 MHz- USB Transmitter

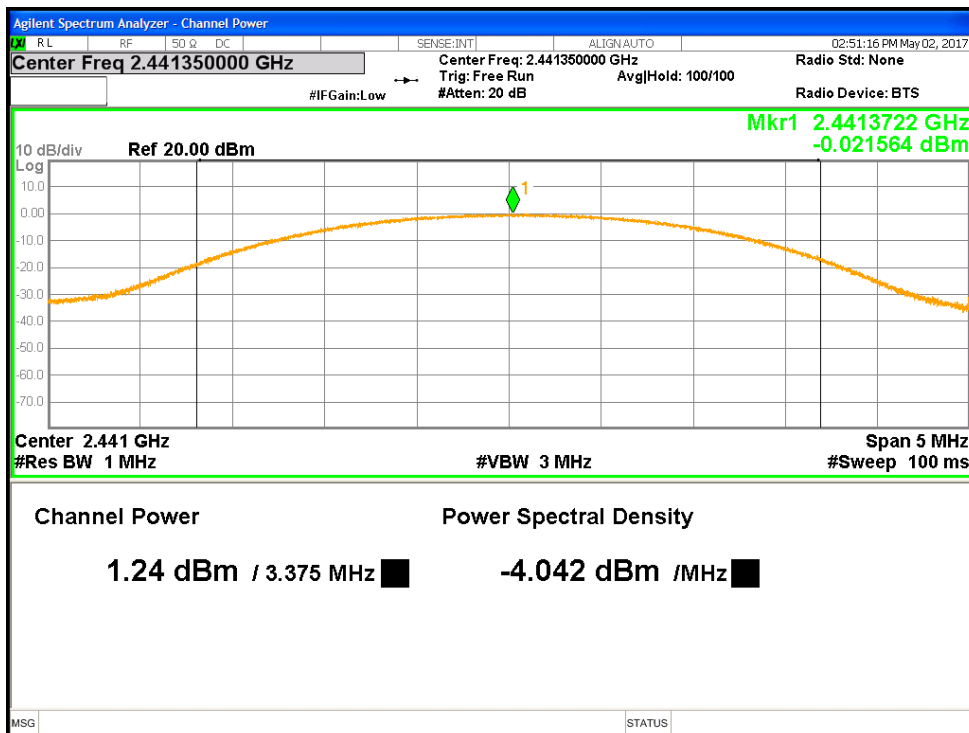

Figure 3: Maximum Conducted Output Power at 2441.35 MHz - USB Transmitter

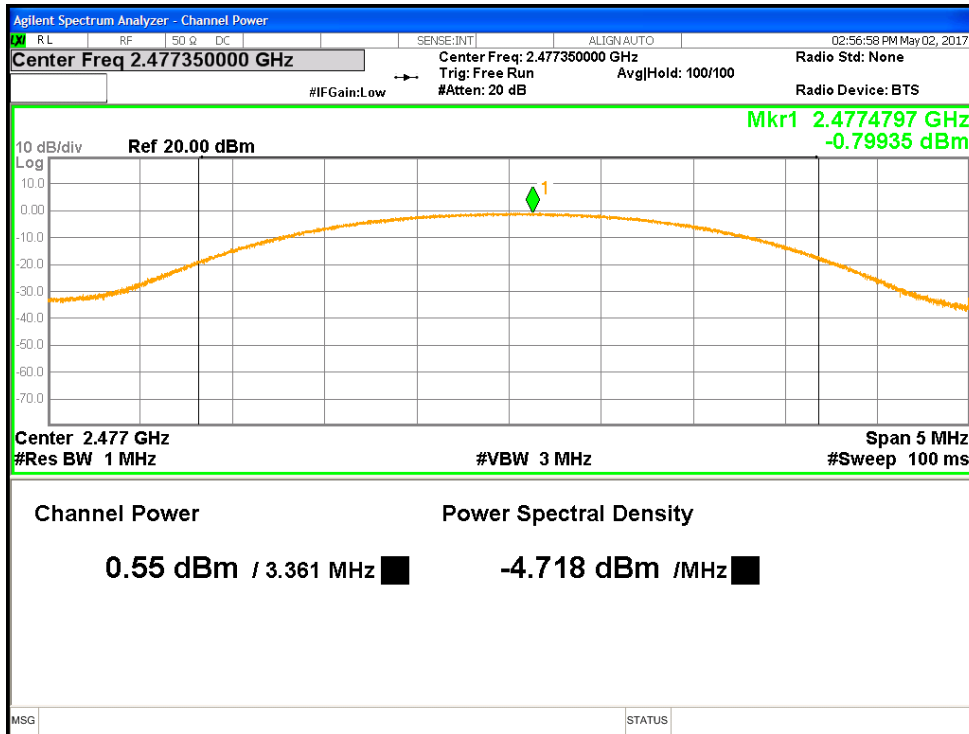

Figure 4: Maximum Conducted Output Power at 2477.35 MHz - USB Transmitter

4.2 Occupied Bandwidth

The occupied bandwidth is measured at an amplitude level reduced from the reference level by a specified ratio. The reference level is the level of the highest amplitude signal observed from the transmitter at the fundamental frequency.

The 99% bandwidth is the bandwidth in which 99% of the transmitted power occupied.

The minimum 6 dB bandwidth shall be at least 500 kHz.

The bandwidth shall be at least 500 kHz per Section CFR47 15.247(a2) 2017 and RSS 247 Sect.5.2.1: 2017

4.2.1 Test Method

The conducted method was used to measure the occupied bandwidth according to ANSI C63.10:2013 Section 11.8.1. The measurement was performed with modulation per CFR47 15.247(a) (2) 2017 and RSS Gen Sect. 6.6 2014. The preliminary investigation was performed to find the narrowest 6 dB bandwidth for each operational mode at different data rates. This worst finding was performed on 3 channels in each operating frequency range; 2400 MHz to 2483.5 MHz. This test was conducted on 3 channels in each mode of Sample S/N PP #1. The worst sample result indicated below.

Test Setup:

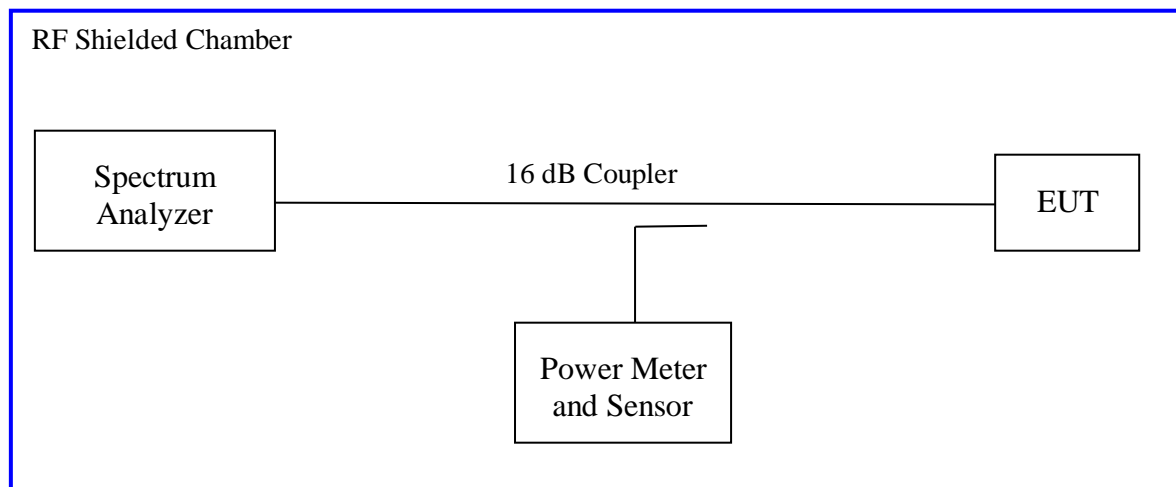

4.2.2 Results

As originally tested, the EUT was found to be compliant to the requirements of the test standard(s).

Table 3: Occupied Bandwidth – Test Results

Test Conditions: Conducted Measurement		Date: May 2, 2017		
Antenna Type: Integrated		Power Setting: 0 dBm		
Antenna Gain: -0.5 dBi		Signal State: Modulated at 100%		
Ambient Temp.: 23 °C		Relative Humidity: 33%		
Bandwidth (MHz) for USB Wireless Audio Transmitter				
Frequency (MHz)	Limit (kHz)	99% Bandwidth	6 dB Bandwidth	Results
2403.35	500	1.919	1.578	Pass
2441.35	500	1.917	1.634	Pass
2477.35	500	1.917	1.573	Pass
Note: The bandwidth was measured at 100% duty cycle				

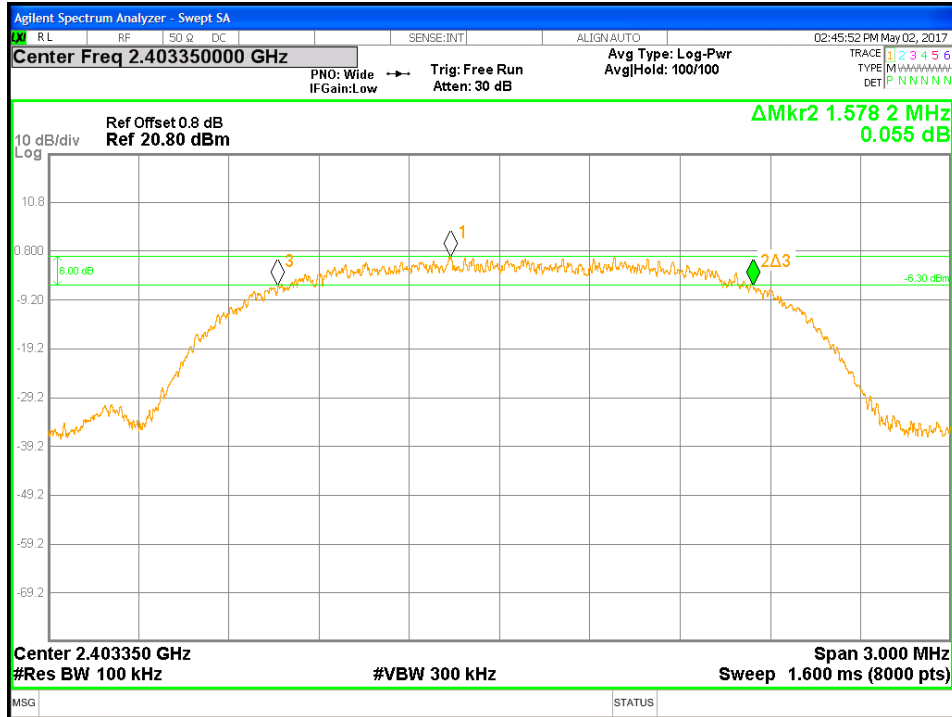

Figure 5: DTS Bandwidth-Transmitter -2403.35 MHz



Figure 6: DTS Bandwidth-Transmitter -2441.35 MHz

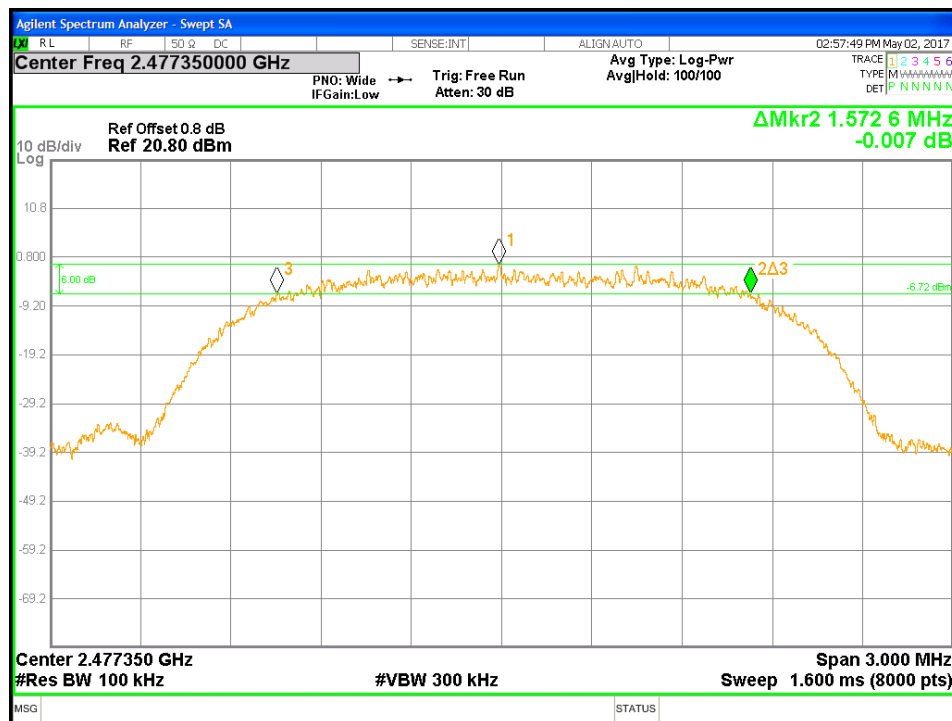

Figure 7: DTS Bandwidth-Transmitter -2477.35 MHz

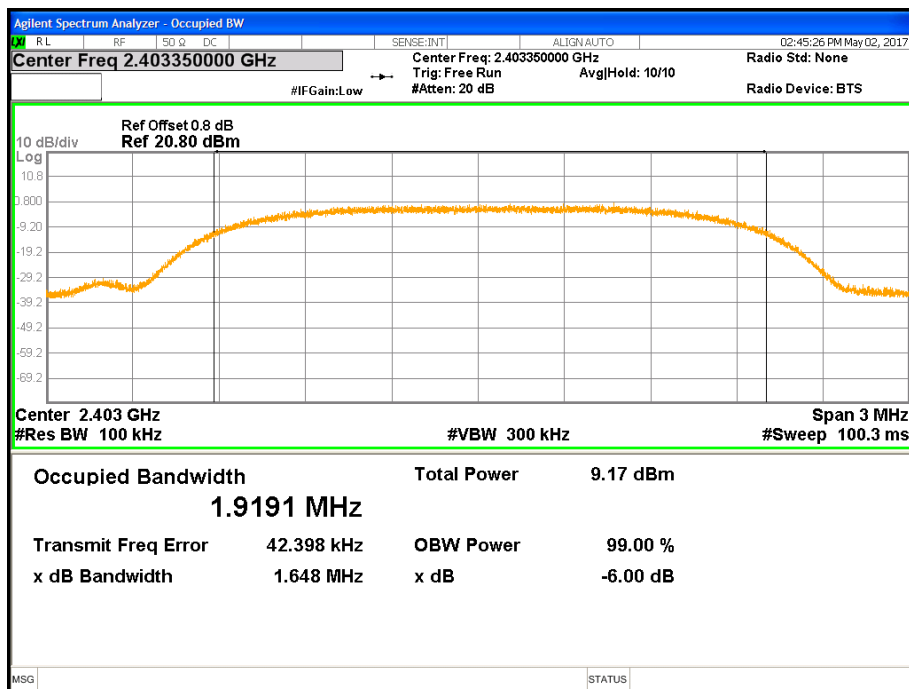

Figure 8: 99% Bandwidth-Transmitter -2403.35 MHz

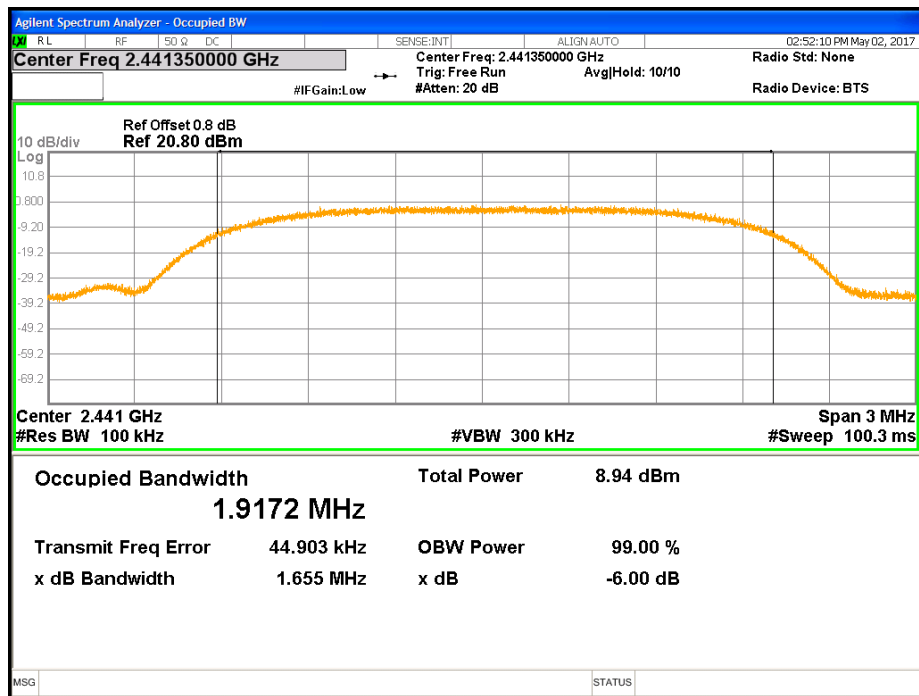

Figure 9: 99% Bandwidth-Transmitter -2441.35 MHz

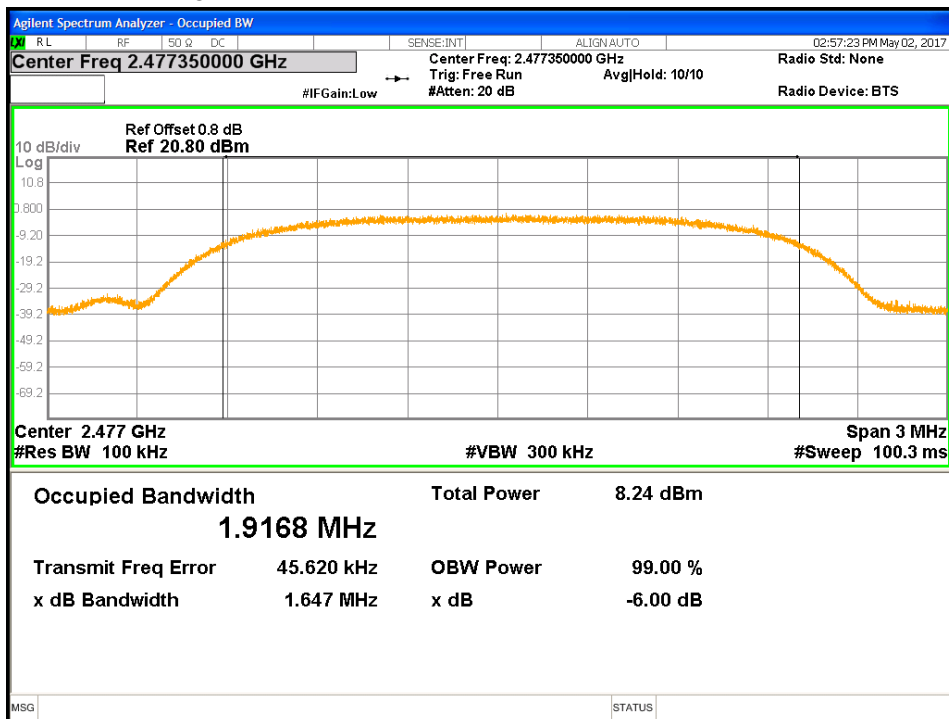

Figure 10: 99% Bandwidth-Transmitter -2477.35 MHz

4.3 Peak Power Spectral Density

According to the CFR47 Part 15.247 (e) and RSS 247 Sect.5.2.2, the power spectral density conducted from the intentional radiator to the antenna shall not be greater than 8 dBm in any 3 kHz band during any time interval of continuous transmission.

4.3.1 Test Method

The conducted method was used to measure the channel power output per ANSI C63.10-2013 Section 11.10.3. The measurement was performed with modulation per CFR47 Part 15.247 (e) and RSS 247 Sect.5.2.2. The pre-evaluation was performed to find the worst modes. The worst findings were conducted on 3 channels in each operating frequency range of 2400 MHz to 2483.5 MHz. This test was conducted on 3 channels of Sample SN PP #1. The worst sample result indicated below.

Test Setup:

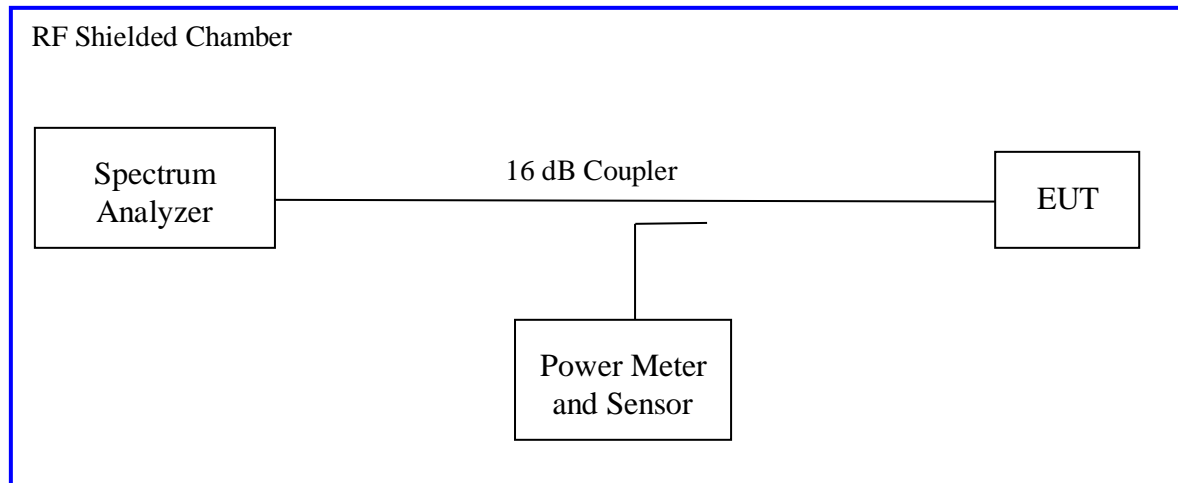

4.3.2 Results

As originally tested, the EUT was found to be compliant to the requirements of the test standard(s).

Table 4: Peak Power Spectral Density – Test Results

Test Conditions: Conducted Measurement			Date: May 2, 2017			
Antenna Type: Integrated			Power Setting: 0 dBm			
Antenna Gain: -0.5 dBi			Signal State: Modulated at 100%			
Ambient Temp.: 23 °C			Relative Humidity: 33%			
Peak Power Spectral Density						
Freq. (MHz)	Config.	Output [dBm]	CF [dB]	Max. PPSD [dBm]	Limit [dBm]	Margin [dB]
2403.35	Transmitter	-8.63	-15.23	-23.86	8.00	-31.86
2441.35	Transmitter	-8.94	-15.23	-24.17	8.00	-32.17
2477.35	Transmitter	-9.71	-15.23	-24.94	8.00	-32.94
Note: CF accounted for the measured RBW. The bandwidth ratio is $10 \cdot \log(3\text{kHz}/100\text{kHz})$ or -15.23 dB. Transmitter transmitted at 100% duty cycle.						

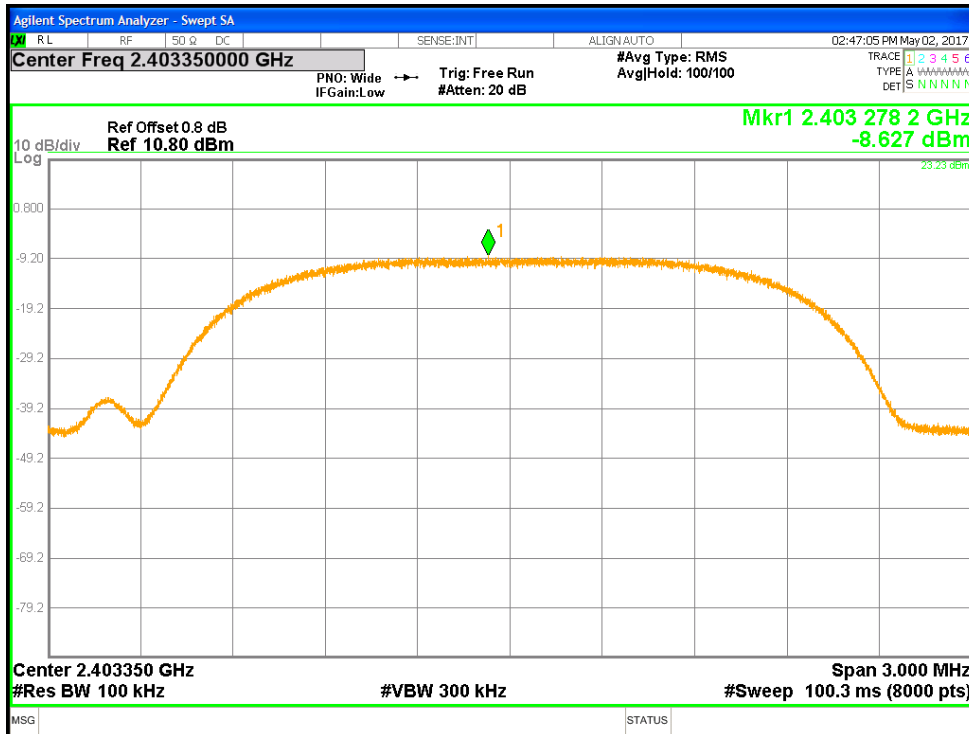

Figure 11: Maximum Power Spectral Density-2403.35 MHz-Transmitter

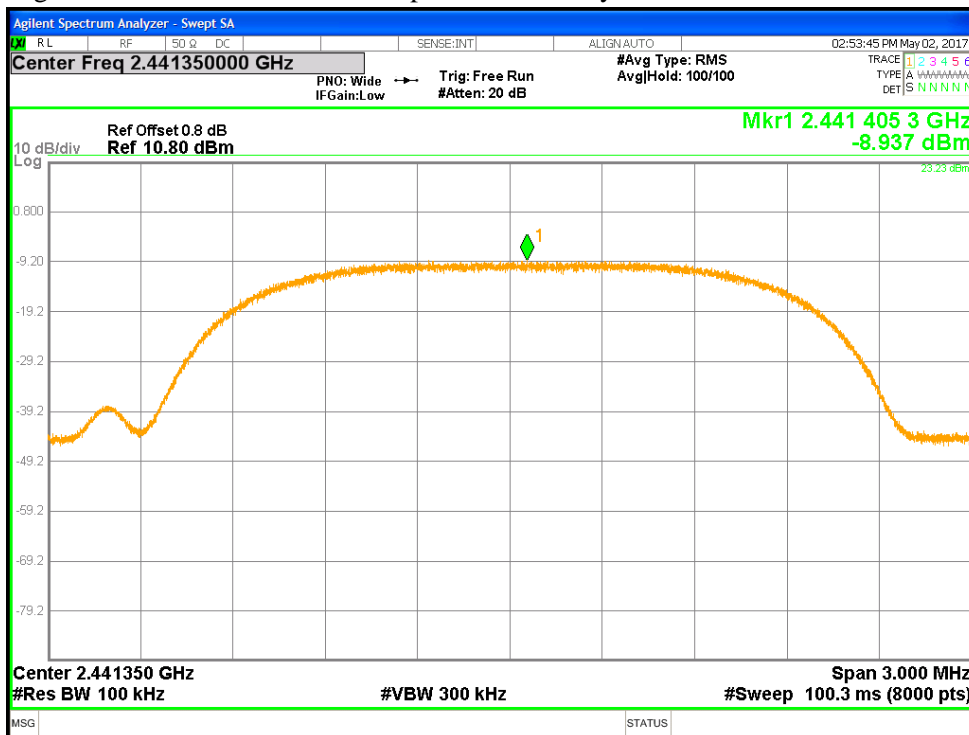

Figure 12: Maximum Power Spectral Density-2441.35 MHz-Transmitter

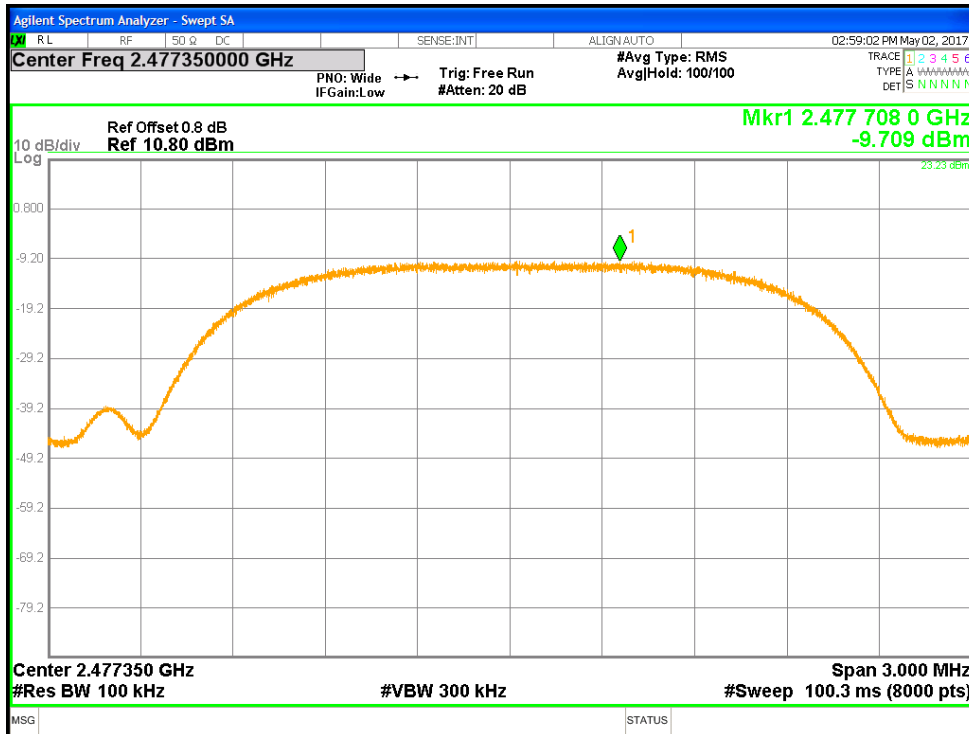

Figure 13: Maximum Power Spectral Density-2477.35 MHz-Transmitter

4.4 Out of Band Emissions

The setup was identical to RF output power measurement. Intentional radiators operating under the alternative provisions to the general emission limits, must be designed to ensure that the 20 dB or 30 dB bandwidth of the emission, or whatever bandwidth may otherwise be specified in the specific rule section under which the equipment operates, is contained within the frequency band designated in the rule section under which the equipment is operated. The requirement to contain the designated bandwidth of the emission within the specified frequency band includes the effects from frequency sweeping, frequency hopping and other modulation techniques that may be employed as well as the frequency stability of the transmitter over expected variations in temperature and supply voltage. If the frequency stability is not specified in the regulations, it is recommended that the fundamental emission be kept within at least the central 80% of the permitted band in order to minimize the possibility of out-of-band operation.

Since the transmitter complies with the conducted power limits base on the use of RMS averaging per CFR47 Part 15.247(b)(3), any frequency outside the band of 2400MHz to 2483.5MHz, the power output level must be below 30db from the in-band transmitting signal; CFR 47 Part 15.215, 15.247(d) and RSS-247 Sect.5.5..

4.4.1 Test Method

The conducted method was used to measure the out-of-band emission requirement. The measurement was performed with modulation per CFR47 15.247(4) (d) 2017 and RSS-247 Sect.5.5: 2017. This test was conducted on 3 channels of Sample S/N PP #1. The worst sample result indicated below.

Test Setup:

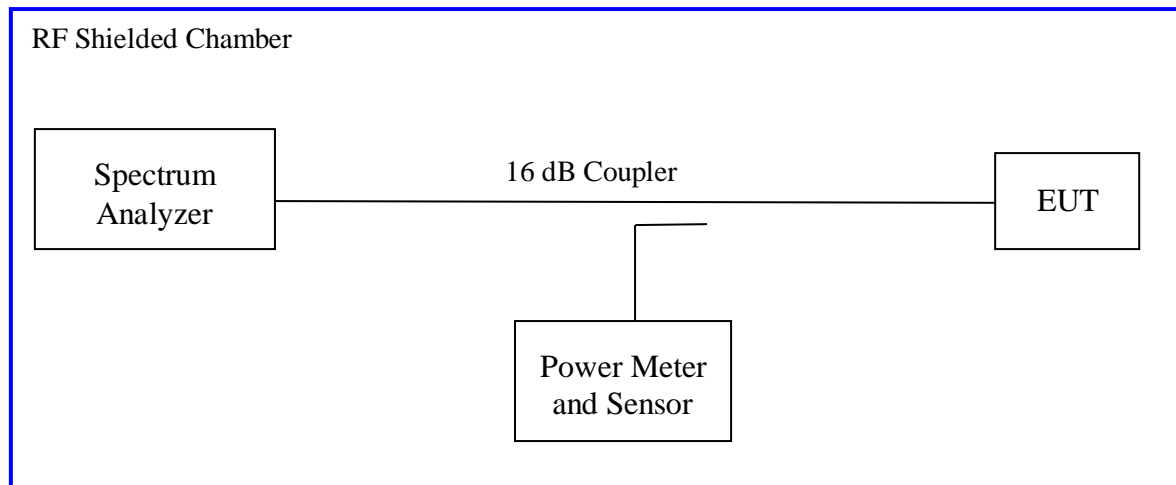

4.4.2 Results

As originally tested, the EUT was found to be compliant to the requirements of the test standard(s).

Table 5: Out of Band Emissions – Test Results

Test Conditions: Conducted Measurement		Date: May 2, 2017	
Antenna Type: Integrated		Power Setting: 0 dBm	
Antenna Gain: -0.5 dBi		Signal State: Modulated at 100%	
Ambient Temp.: 23 °C		Relative Humidity: 33%	
Out of Band Results for USB Wireless Audio Transmitter			
Operating Channel	Out of Band Level (dBm)	30 dBc Level (dBm)	Margin (dB)
2403.35 MHz	-51.94	-30.97	-20.97
2441.35 MHz	-51.45	-31.24	-20.21
2477.35 MHz	-50.38	-31.51	-18.87
<p>Note: dBc is defined as the level below the main carrier. The band-edge level must lower than the 30dBc level. The maximum out of band emission on each individual output put is at least 30 dB below the maximum in-band PSD on that output. (*) The band-edge is compared to the highest -30dBc level of the test mode.</p>			

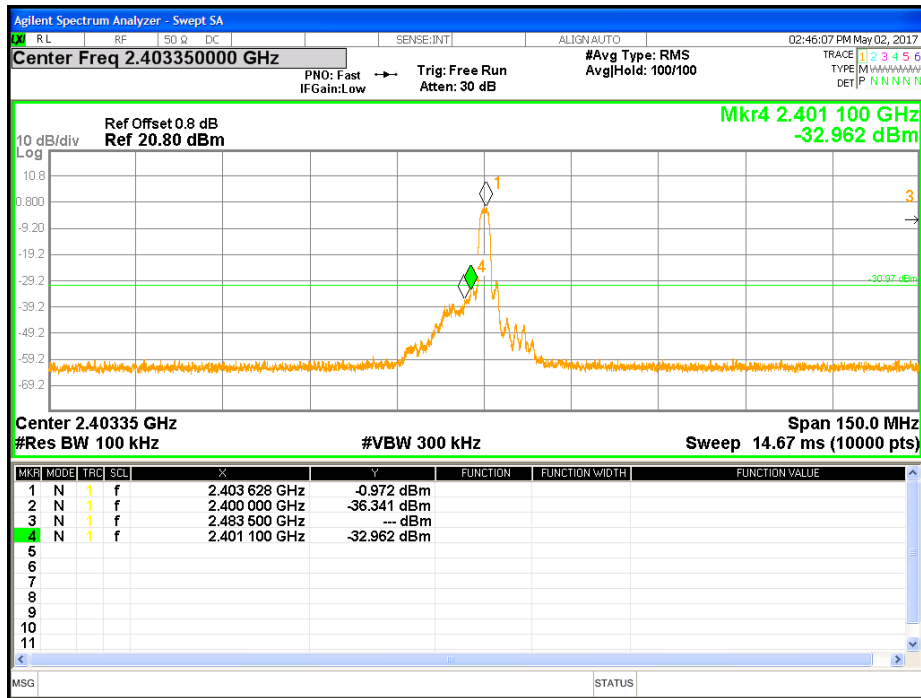

Figure 14: Conducted Band Edge at 2403.35 MHz-Transmitter

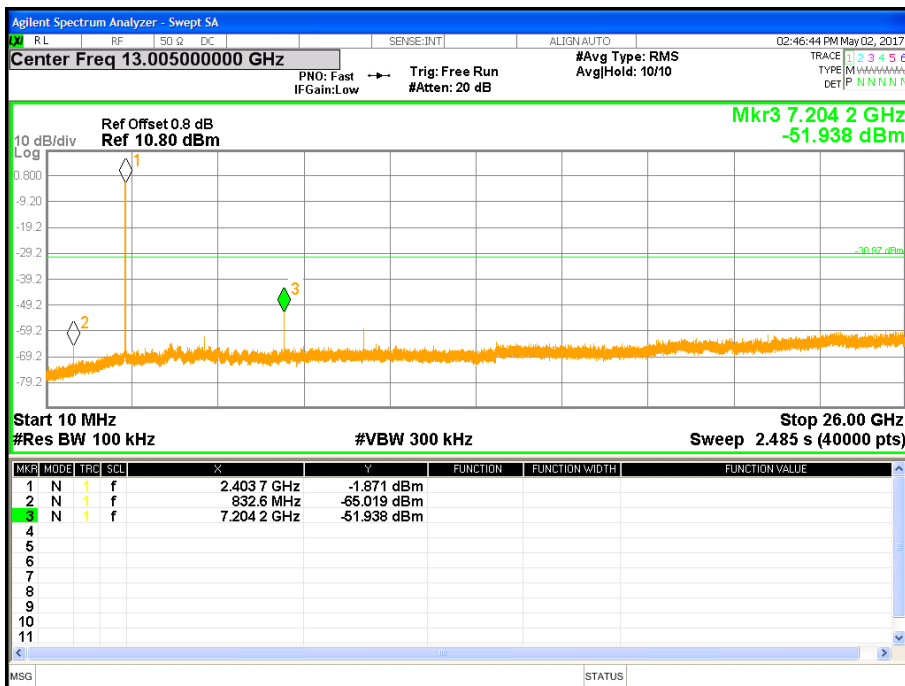

Figure 15: Out of band Emission-2403.35 MHz-Transmitter

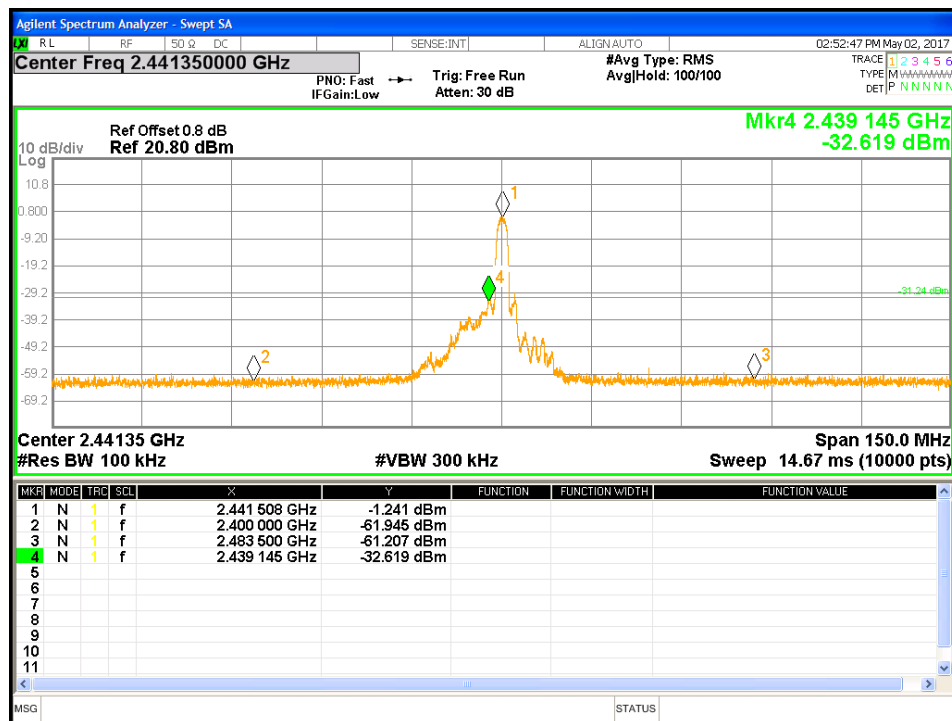

Figure 16: Conducted Band Edge-2441.35 MHz-Transmitter

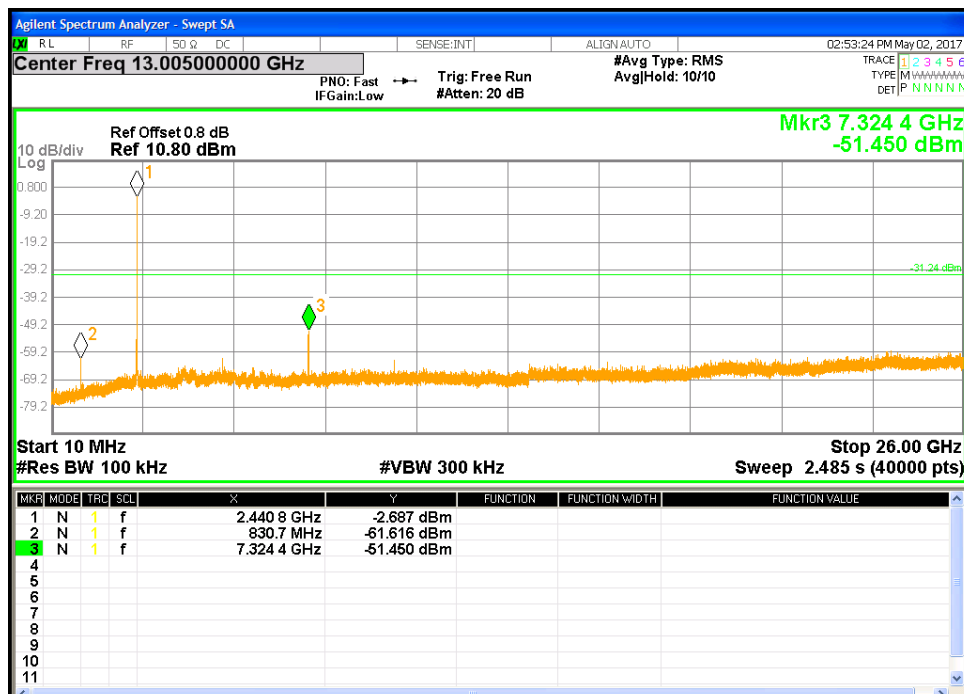

Figure 17: Out of band Emission-2441.35 MHz-Transmitter

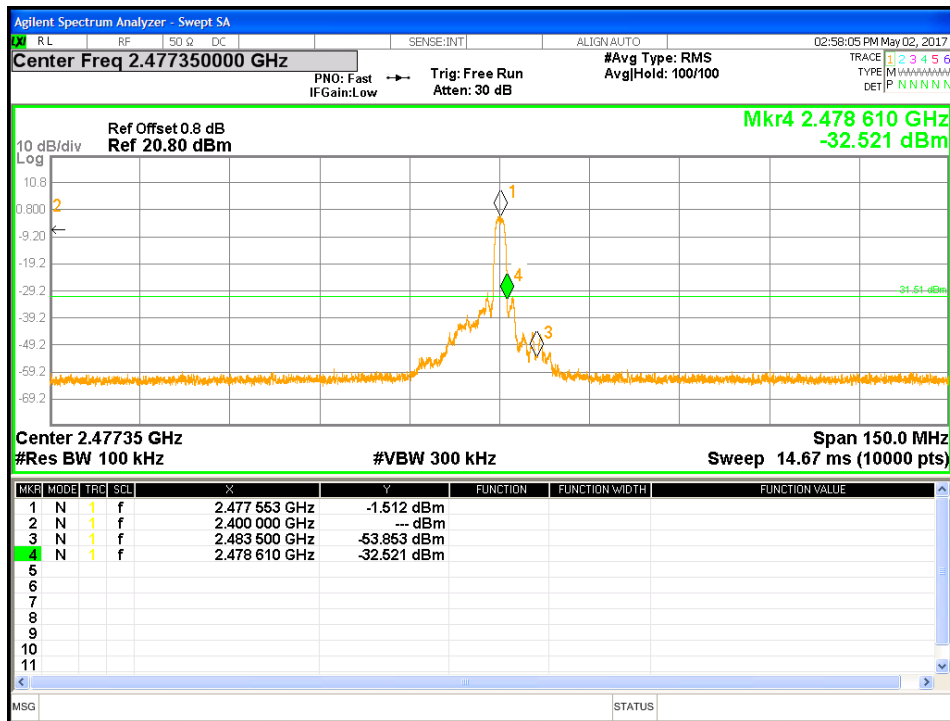

Figure 18: Conducted Band Edge-2477.35 MHz-Transmitter

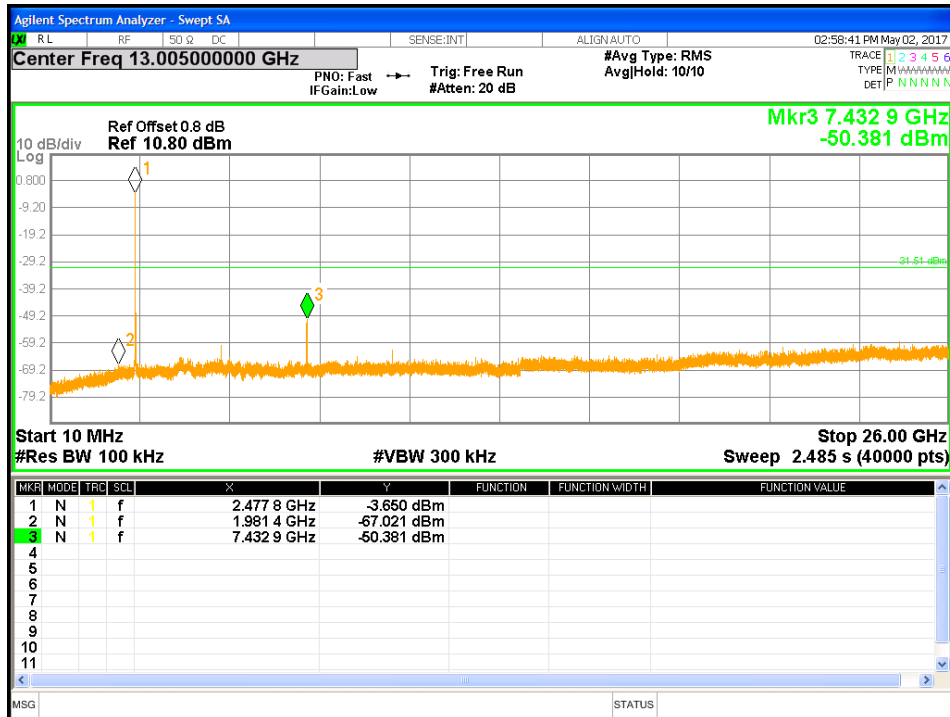

Figure 19: Out of band Emission-2477.35 MHz-Transmitter

4.5 Maximum Permissible Exposure

4.5.1 Test Methodology

In this section, we try to prove the safety of radiation harmfulness to the human body for our product. The KDB 447498 D01 General RF Exposure Guidance is followed. The Gain of the antenna used in this calculation is declared by the manufacturer, and the maximum average power input to the antenna is measured. Using the general SAR test exclusion guidance in Section 4.3 of KDB 447498, we show the device meeting the SAR exclusion threshold.

4.5.2 FCC KDB 447498 D01 – General SAR Test Exclusion Guidance

The SAR exclusion threshold conditions are listed:

1) The 1-g and 10-g SAR test exclusion thresholds for 100 MHz to 6 GHz at test separation distances ≤ 50 mm are determined by:

$[(\text{max. power of channel, including tune-up tolerance, mW}) / (\text{min. test separation distance, mm})] \cdot [\sqrt{f(\text{GHz})}] \leq 3.0$ for 1-g SAR and ≤ 7.5 for 10-g extremity SAR, 16 where

- $f(\text{GHz})$ is the RF channel transmit frequency in GHz
- Power and distance are rounded to the nearest mW and mm before calculation¹⁷
- The result is rounded to one decimal place for comparison

The test exclusions are applicable only when the minimum test separation distance is ≤ 50 mm and for transmission frequencies between 100 MHz and 6 GHz. When the minimum test separation distance is < 5 mm, a distance of 5 mm is applied to determine SAR test exclusion.

2) At 100 MHz to 6 GHz and for test separation distances > 50 mm, the SAR test exclusion threshold is determined according to the following, and as illustrated in Appendix B: 18

- a) $[\text{Threshold at 50 mm in step 1}) + (\text{test separation distance} - 50 \text{ mm}) \cdot (f(\text{MHz})/150)]$ mW, at 100 MHz to 1500 MHz
- b) $[\text{Threshold at 50 mm in step 1}) + (\text{test separation distance} - 50 \text{ mm}) \cdot 10]$ mW at > 1500 MHz and ≤ 6 GHz

3) At frequencies below 100 MHz, the following may be considered for SAR test exclusion, and as illustrated in Appendix C: 19

- a) The threshold at the corresponding test separation distance at 100 MHz in step 2) is multiplied by $[1 + \log(100/f(\text{MHz}))]$ for test separation distances > 50 mm and < 200 mm
- b) The threshold determined by the equation in a) for 50 mm and 100 MHz is multiplied by $1/2$ for test separation distances ≤ 50 mm
- c) SAR measurement procedures are not established below 100 MHz. When SAR test exclusion cannot be applied, a KDB inquiry is required to determine SAR evaluation requirements for any test results to be acceptable.

4.5.3 EUT Operating Condition

The software provided by Manufacturer enabled the EUT to transmit data at lowest, middle and highest channel individually.

4.5.4 Classification

The antenna of the product, under normal use condition, is less than 2cm away from the body of the user. This device is classified as a **Portable Device**. It is intended to be used with head wear device; extremity SAR limit is applied.

4.5.5 SAR Test Exclusion Threshold

4.5.5.1 Antenna Gain

The transmitting antenna was integrated. The omni-directional antenna gain was -0.5 dBi or 0.89 (numeric).

4.5.5.2 SAR Exclusion Threshold Calculation

Mode	Max. Power (dBm)	EIRP (dBm)	Min. Separation Distance (mm)	Cal. Excl. Threshold	1-g SAR Limit	10-g extremity SAR Limit	Result
Modulated	1.47	0.97	5	0.39406	≤3.0	≤7.5	Exempted *

Note:

1. Since EUT can operate at distance less than 50 mm, the minimum distance, 5 mm, was used for calculation per condition #1 of SAR Exclusion Threshold.
2. The maximum output power was taken from Sect. 4.1
3. (*)The calculated threshold is less than 3.0; therefore, EUT is SAR exempted for head and body usage.

4.6 Transmit Spurious Emissions

Transmitter spurious emissions are emissions outside the frequency range of the equipment when the equipment is in transmit mode; per requirement of CFR47 15.205, 15.209, 15.247(d), RSS-Gen Sect. 8.9.

4.6.1 Test Methodology

4.6.1.1 Preliminary Test

A test program that controls instrumentation and data logging was used to automate the preliminary RF emission test procedure. The frequency range of interest was divided into sub-ranges to yield a frequency resolution of approximately 120 kHz and provide a reading at each frequency for no more than 12° of turntable rotation. For each frequency sub-range the turntable was rotated 360° while peak emission data was recorded and plotted over the frequency range of interest in horizontal and vertical antenna polarization's.

Preliminary emission profile testing was performed inside the anechoic chamber. The EUT was placed on a 1.0m x 1.5m non-conductive table 80cm (<1 GHz) and 150cm (>1 GHz) above the floor. The EUT was positioned as shown in the setup photographs. The receiving antenna was placed at a distance of 3m at a fixed height of 1m. Measurement equipment was located outside of the chamber. A video camera was placed inside the chamber to view the EUT.

Pres-scans were performed to determine the worst case configuration for data rate.

4.6.1.2 Final Test

For each frequency measured, the peak emission was maximized by manipulating the receiving antenna from 1 to 4 meters above the ground plane and placing it at the position that produced the maximum signal strength reading. The turntable was then rotated through 360° while observing the peak signal and placing the EUT at the position that produced maximum radiation. The six highest emissions relative to the limit were measured unless such emissions were more than 20 dB below the limit. If less than six emissions are within 20 dB of the limit, than the noise level of the receiver is measured at frequencies where emissions are expected. Multiples of all oscillator and microprocessor frequencies were also checked.

Final testing was performed on an NSA compliant test site. The EUT was placed on a 1.0m x 1.5m non-conductive table 80cm (<1 GHz) and 150cm (>1 GHz) above the ground plane. The placement of EUT and cables were the same as for preliminary testing and is shown in the setup photographs.

The final scans performed on the worst axis, Y-Axis, for three operating channels in each operating mode;

2403.35 MHz, 2441.35 MHz, and 2477.35 MHz

4.6.1.3 Deviations

None.

Test Setup:

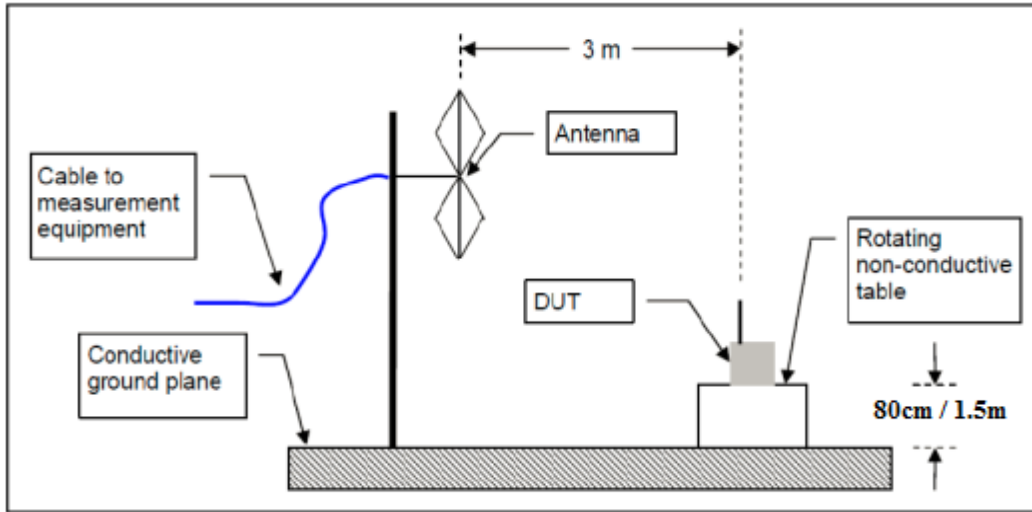

4.6.2 Transmitter Spurious Emission Limit

The spurious emissions of the transmitter shall not exceed the values in CFR47 Part 15.205, 15.209: 2017 and RSS Gen Sect. 8.10: 2014.

Frequency (MHz)	Field strength (microvolts/meter)	Measurement distance (meters)
0.009-0.490	2400/F (kHz)	300
0.490-1.705	24000/F (kHz)	30
1.705-30.0	30	30
30-88	100 **	3
88-216	150 **	3
216-960	200 **	3
Above 960	500	3

All harmonics and spurious emission which are outside of the restricted band shall be 20dB below the in-band emission.

4.6.3 Test Results

The final measurement data was taken under the worst case operating modes, configurations, and/or cable positions. It also reflects the results including any modifications and/or special accessories listed in Sections 1.4 and test plan.

As originally tested, the EUT was found to be compliant to the requirements of the test standard(s).

Table 6: Transmit Spurious Emission at Band-Edge Requirements

Test Conditions: Radiated Measurement, Normal Temperature and Voltage only					Date: May 2, 2017				
Antenna Type: Integrated					Power Setting: 0 dBm				
Max. Antenna Gain: -0.5 dBi					Signal State: Modulated at 100%				
Ambient Temp.: 23 °C					Relative Humidity: 33%				
Band-Edge Results									
Center Freq.	Position	Edge Freq.	Pol	Ant.	Table	Det.	Level	Limit	Margin
MHz		MHz	V/ H	cm	Deg.	Pk/A vg	dBuV/ m	dBuV/ m	dB
2403.35	Up Right	2390.0	V	151	159	Pk	59.57	74.00	-14.43
2403.35	Up Right	2390.0	V	151	159	Ave	48.84	54.00	-5.16
2403.35	Up Right	2390.0	V	157	195	Pk	57.65	74.00	-16.35
2403.35	Up Right	2390.0	H	157	195	Ave	47.16	54.00	-6.84
2477.35	Up Right	2483.5	V	40	204	Pk	57.80	74.00	-16.20
2477.35	Up Right	2483.5	V	40	204	Ave	46.51	54.00	-7.49
2477.35	Up Right	2483.5	H	170	179	Pk	58.10	74.00	-15.90
2477.35	Up Right	2483.5	H	170	179	Ave	47.16	54.00	-6.84
Note: The emissions were measured at the adjacent restricted band of the fundamental signal. All the band-edge measurements met the restricted band requirements of CFR47 15.205									

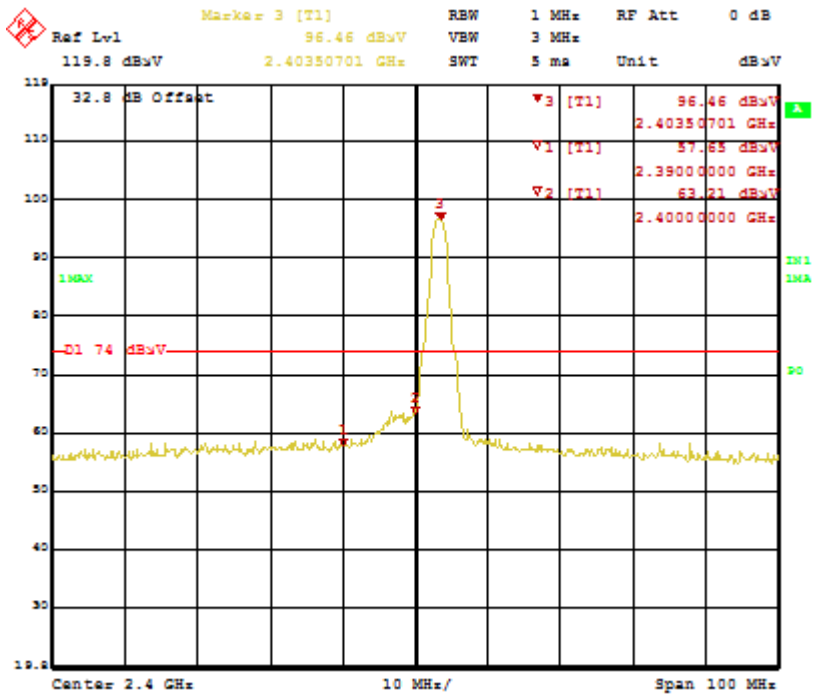

Figure 20: Bandedge-2403.35 MHz-H-Pk

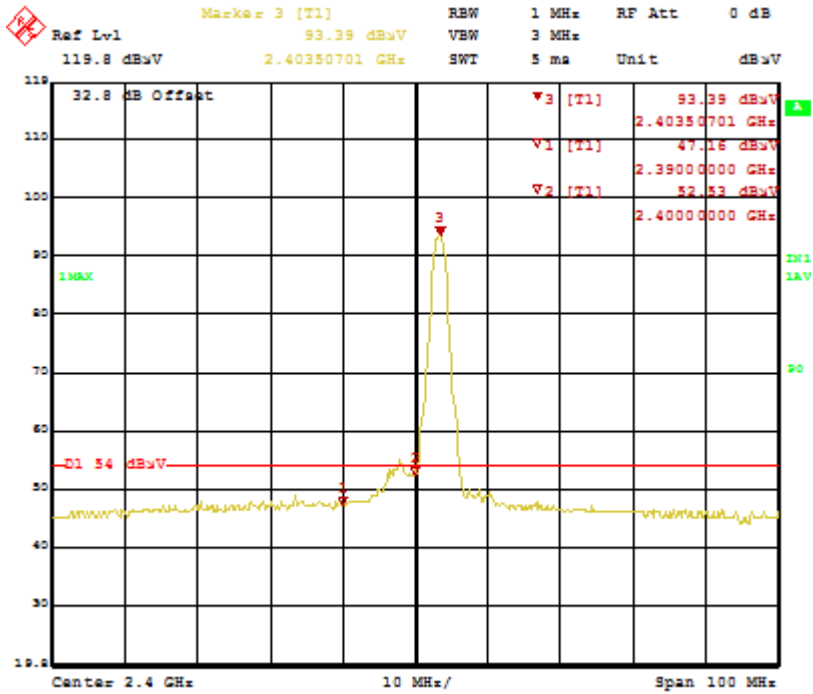

Figure 21: Bandedge-2403.35 MHz-H-Ave

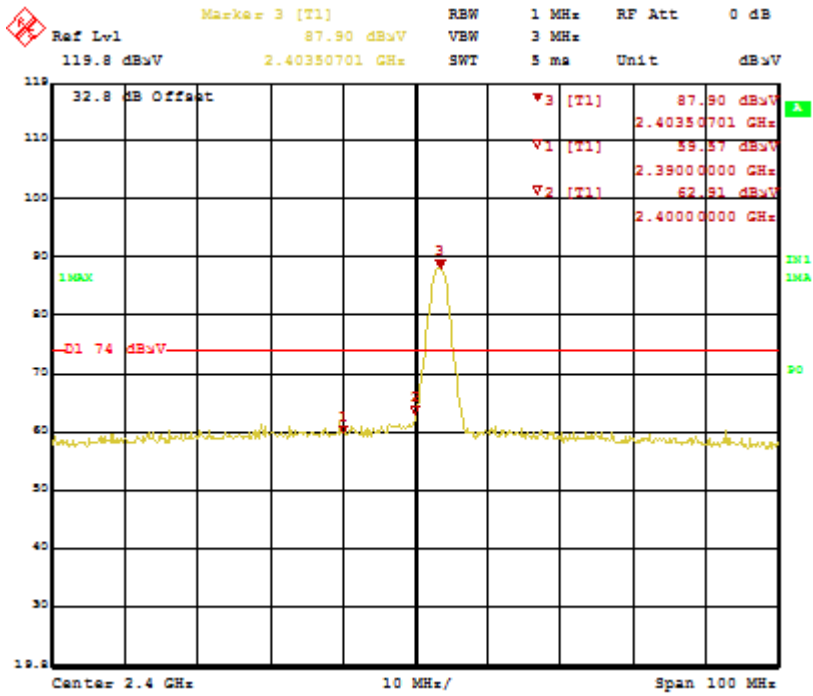

Figure 22: Bandedge-2403.35 MHz-V-Pk

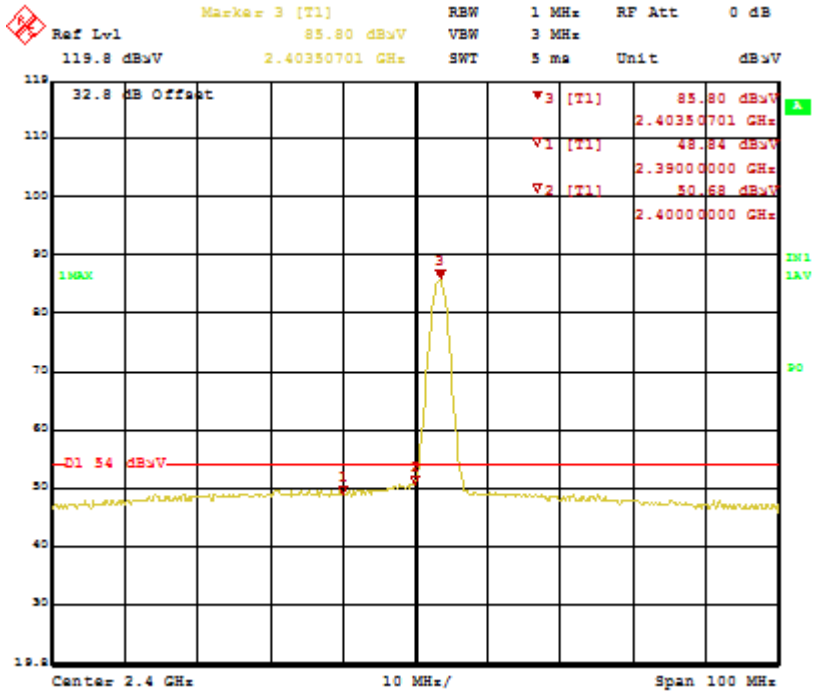

Figure 23: Bandedge-2403.35 MHz-V-Ave

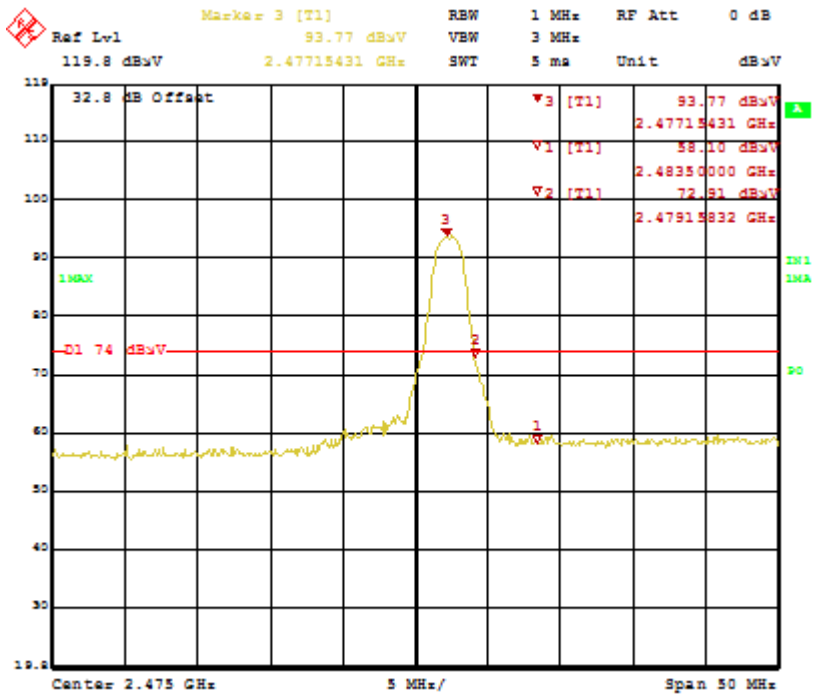

Figure 24: Bandedge-2477.35 MHz-H-Pk

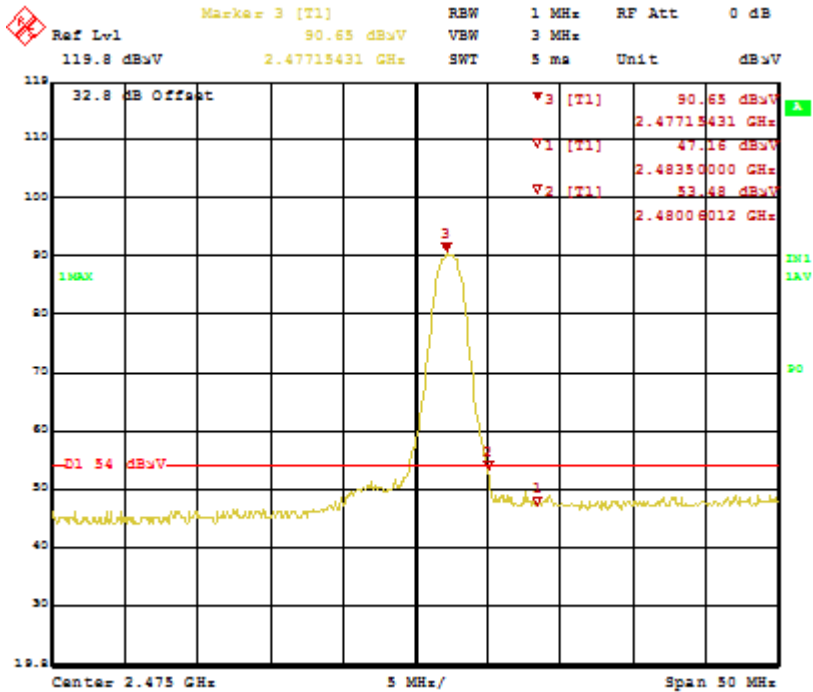

Figure 25: Bandedge-2477.35 MHz-H-Ave

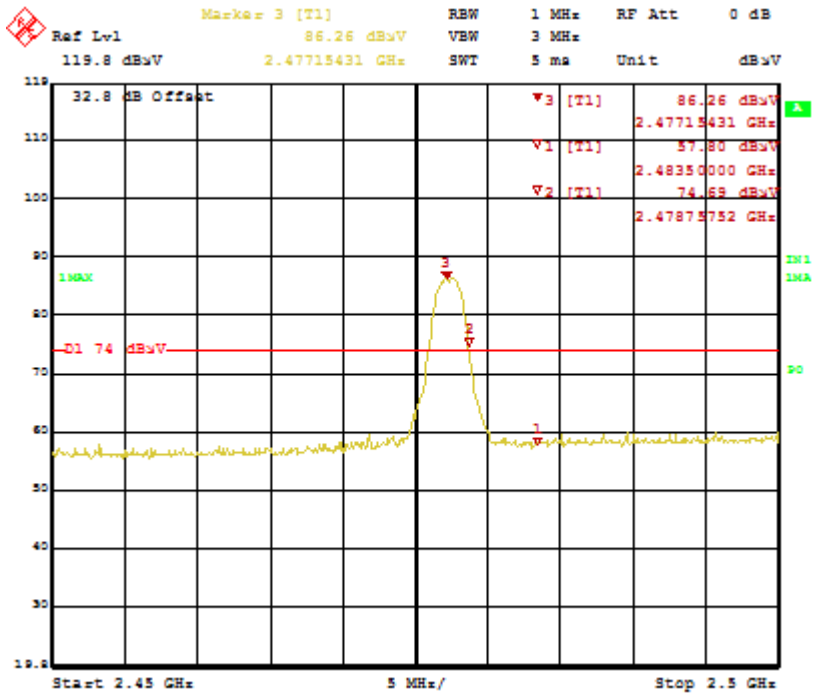

Figure 26: Bandedge-2477.35 MHz-V-Pk

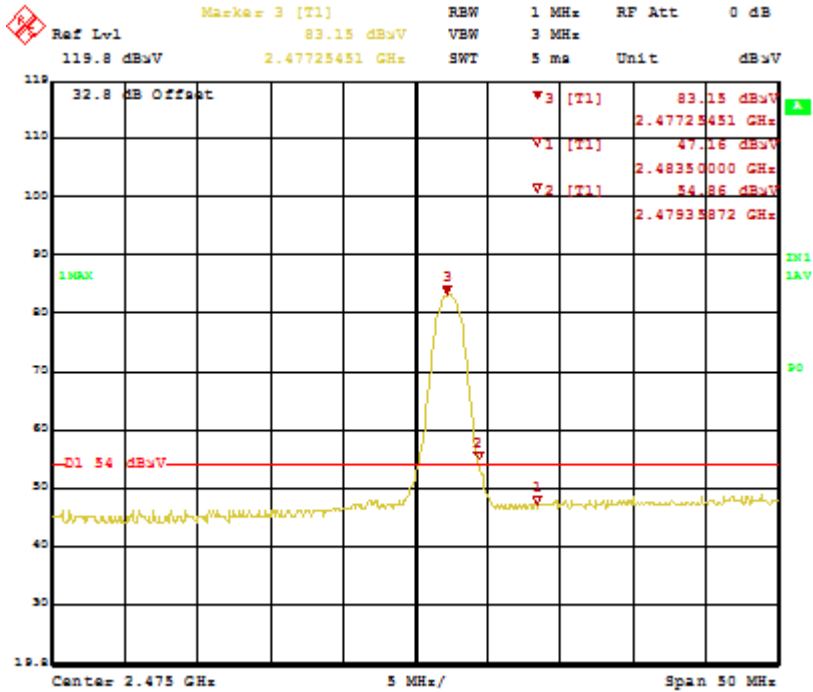

Figure 27: Bandedge-2477.35 MHz-V-Ave

SOP 1 Radiated Emissions											Tracking # 31761757.001 Page 1 of 6	
EUT Name		USB Wireless Audio Transmitter					Date		May 4, 2017			
EUT Model		Ear Force Stealth 600P TX					Temp / Hum in		23°C / 33%rh			
EUT Serial		PP #2					Temp / Hum out		N/A			
EUT Config.		X-Axis					Line AC / Freq		5.0 VDC			
Standard		CFR47 Part 15 Subpart C					RBW / VBW		120 kHz/ 300 kHz			
Dist/Ant Used		3m / JB3					Performed by		Jeremy Luong			
Freq.	Raw	Cbl	AF	Level	Det.	Pol.	Hght.	Azt	Limit	Margin	Result	
MHz	dBuV/m	dB	dB	dBuV/m		H/V	cm	deg	dBuV/m	dB		
9 kHz to 1 GHz, Transmitted Data at 2403.35 MHz												
32.63	28.18	2.59	-9.12	21.64	QP	V	127	261	40.00	-18.36	Pass	
41.84	26.78	2.67	-15.22	14.22	QP	V	196	138	40.00	-25.78	Pass	
43.96	25.62	2.69	-16.60	11.71	QP	V	152	246	40.00	-28.30	Pass	
60.12	39.15	2.81	-20.71	21.25	QP	V	200	320	40.00	-18.75	Pass	
60.90	31.85	2.82	-20.63	14.04	QP	V	108	272	40.00	-25.96	Pass	
494.62	22.27	4.52	-10.21	16.58	QP	V	161	360	46.00	-29.42	Pass	
Spec Margin = Level - Limit, Level = Raw+ Cbl+ CF ± Uncertainty												
CF= Amp Gain + ANT Factor												
Combined Standard Uncertainty $u_c(y) = \pm 3.2$ dB Expanded Uncertainty $U = ku_c(y)$ $k = 2$ for 95% confidence												
Note: The worst case emission was observed on Channel 2403.35 MHz.												
No significant emission was observed below 30 MHz.												

SOP 1 Radiated Emissions											Tracking # 31761757.001 Page 2 of 6	
EUT Name		USB Wireless Audio Transmitter					Date		May 4, 2017			
EUT Model		Ear Force Stealth 600P TX					Temp / Hum in		23°C / 33%rh			
EUT Serial		PP #2					Temp / Hum out		N/A			
EUT Config.		Transmitter					Line AC / Freq		5.0 VDC			
Standard		CFR47 Part 15 Subpart C					RBW / VBW		1 MHz / 3 MHz			
Dist/Ant Used		3m / DRH-118, 1m / RA42-K-F-4B-C					Performed by		Jeremy Luong			
Freq	Raw	Cbl	AF	Level	Det	Pol	Hght	Azt	Limit	Margin	Comment	
MHz	dBuV/m	dB	dB	dBuV/m		H/V	cm	deg	dBuV/m	dB		
Transmitted Data at 2403.35 MHz												
1107.14	45.43	0.80	-28.34	17.89	Ave	H	189	188	54.00	-36.11	Spurious	
4807.44	44.20	1.75	-20.11	25.84	Ave	H	174	74	54.00	-28.16	Harmonics	
15401.38	40.80	3.50	-11.94	32.35	Ave	H	138	64	54.00	-21.65	Spurious	
14462.78	40.10	3.23	-8.56	34.77	Ave	V	222	292	54.00	-19.23	Spurious	
Transmitted Data at 2441.35 MHz												
2079.26	44.78	1.11	-25.07	20.83	Ave	H	210	276	54.00	-33.17	Spurious	
4613.58	44.21	1.70	-20.76	25.15	Ave	H	194	320	54.00	-28.85	Spurious	
17754.57	39.85	3.68	-4.33	39.21	Ave	H	131	14	54.00	-14.79	Spurious	
4883.11	47.99	1.77	-20.14	29.62	Ave	V	103	360	54.00	-24.39	Harmonics	
14084.25	40.26	3.22	-8.58	34.90	Ave	V	189	0	54.00	-19.10	Spurious	
Transmitted Data at 2477.35 MHz												
2632.12	45.74	1.27	-24.15	22.86	Ave	H	242	116	54.00	-31.14	Spurious	
3885.94	43.56	1.56	-20.39	24.73	Ave	H	117	83	54.00	-29.27	Spurious	
14075.92	40.19	3.22	-8.61	34.80	Ave	H	150	258	54.00	-19.20	Spurious	
17844.40	40.55	3.71	-3.68	40.58	Ave	H	197	290	54.00	-13.42	Spurious	
4954.41	48.68	1.79	-20.18	30.29	Ave	V	232	360	54.00	-23.71	Harmonics	
15363.05	41.01	3.42	-11.77	32.66	Ave	V	235	278	54.00	-21.34	Spurious	
Spec Margin = Level - Limit, Level = Raw+ Cbl+ CF ± Uncertainty												
CF= Amp Gain + ANT Factor												
Combined Standard Uncertainty $u_c(y) = \pm 3.2\text{dB}$ Expanded Uncertainty $U = k u_c(y)$ $k = 2$ for 95% confidence												
Notes: All emissions passed the spurious emission limit.												

SOP 1 Radiated Emissions

Tracking # 31761757.001 Page 3 of 6

EUT Name	USB Wireless Audio Transmitter	Date	May 4, 2017
EUT Model	Ear Force Stealth 600P TX	Temp / Hum in	23°C / 33%rh
EUT Serial	PP #2	Temp / Hum out	N/A
EUT Config.	Transmitter	Line AC / Freq	5.0 VDC
Standard	CFR47 Part 15 Subpart C	RBW / VBW	120 kHz/ 300 kHz
Dist/Ant Used	3m / JB3	Date	Jeremy Luong

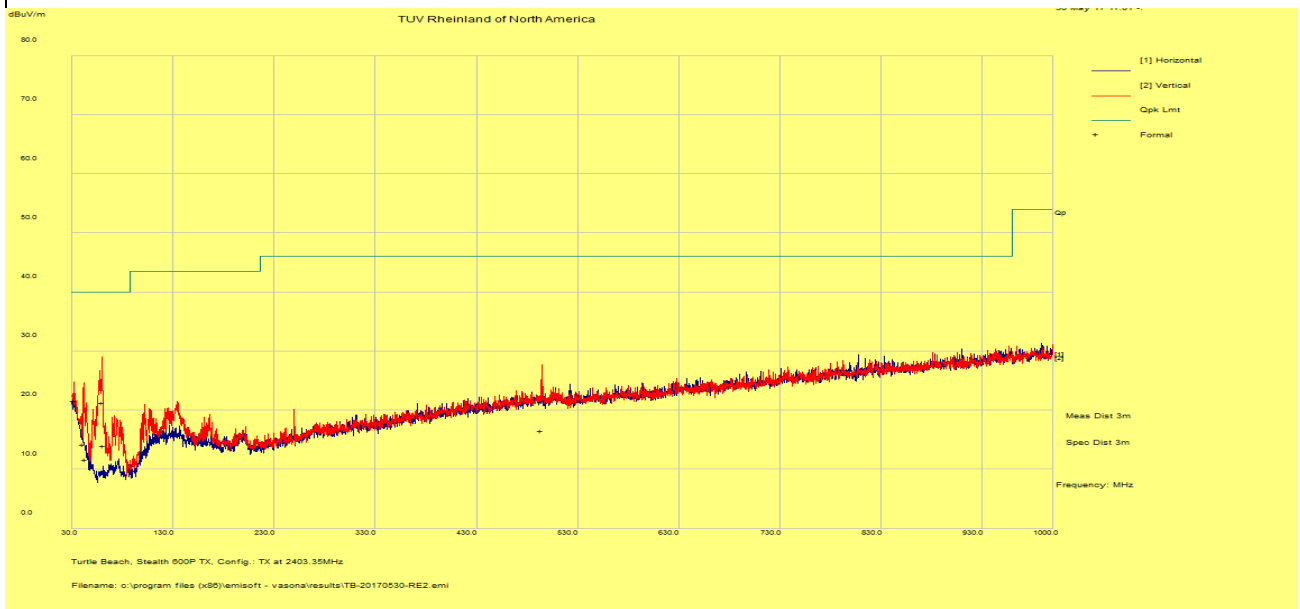
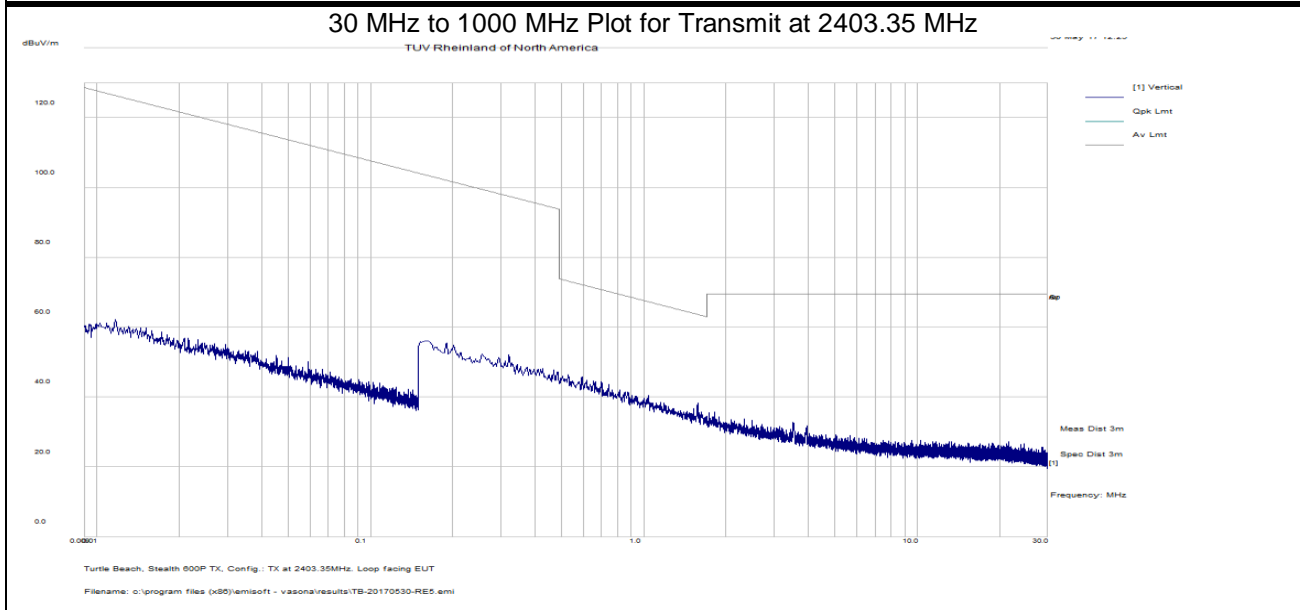

Notes: None.

SOP 1 Radiated Emissions

Tracking # 31761757.001 Page 4 of 6

EUT Name	USB Wireless Audio Transmitter	Date	May 4, 2017
EUT Model	Ear Force Stealth 600P TX	Temp / Hum in	23°C / 33%rh
EUT Serial	PP #2	Temp / Hum out	N/A
EUT Config.	Transmitter	Line AC / Freq	5.0 VDC
Standard	CFR47 Part 15 Subpart C	RBW / VBW	1 MHz / 3 MHz
Dist/Ant Used	3m / DRH-118, 1m / RA42-K-F-4B-C	Performed by	Jeremy Luong

Above 1 GHz Plots for Transmit Mode at 2403.35 MHz

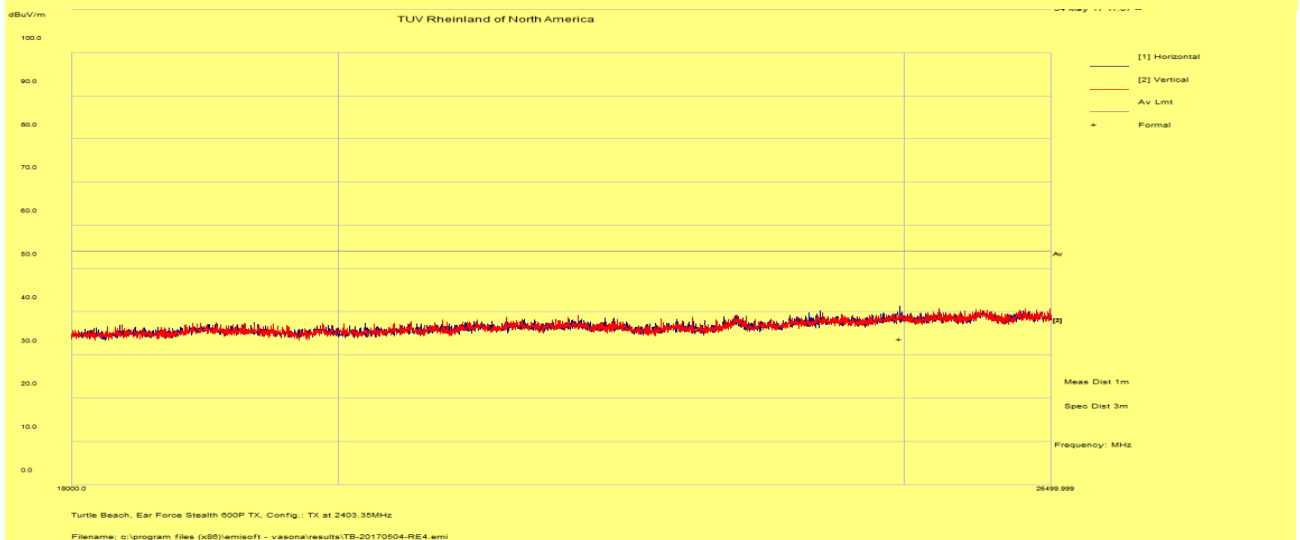
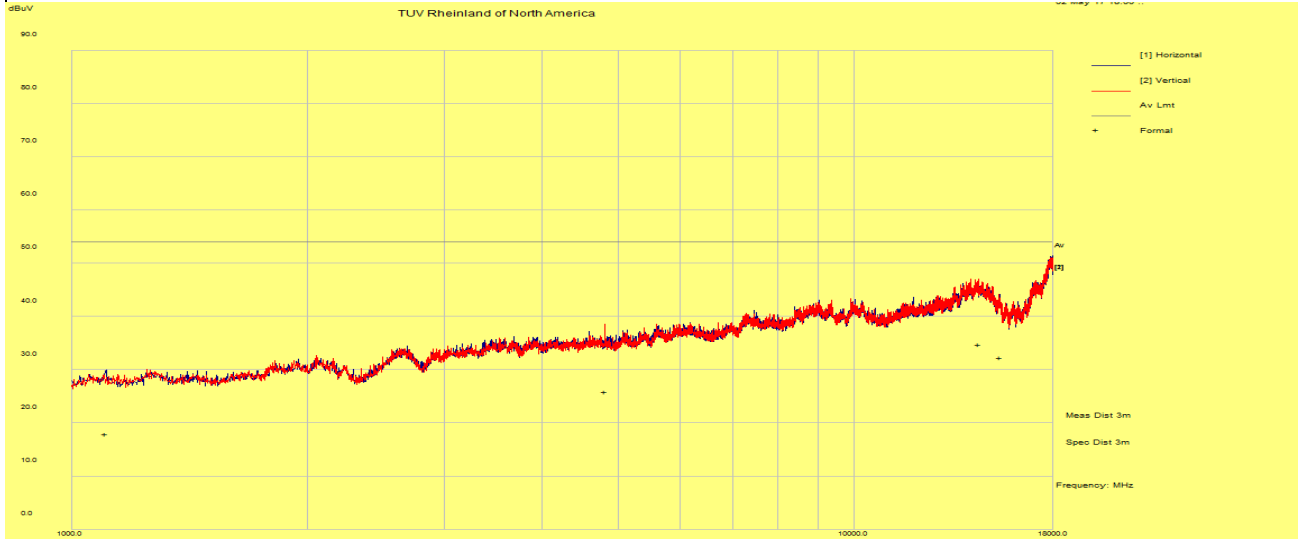

Notes: No emission was observed from 18 to 26 GHz.

SOP 1 Radiated Emissions

Tracking # 31761757.001 Page 5 of 6

EUT Name	USB Wireless Audio Transmitter	Date	May 4, 2017
EUT Model	Ear Force Stealth 600P TX	Temp / Hum in	23°C / 33%rh
EUT Serial	PP #2	Temp / Hum out	N/A
EUT Config.	Transmitter	Line AC / Freq	5.0 VDC
Standard	CFR47 Part 15 Subpart C	RBW / VBW	1 MHz / 3 MHz
Dist/Ant Used	3m / DRH-118, 1m / RA42-K-F-4B-C	Performed by	Jeremy Luong

Above 1 GHz Plots for Transmit Mode at 2441.35 MHz

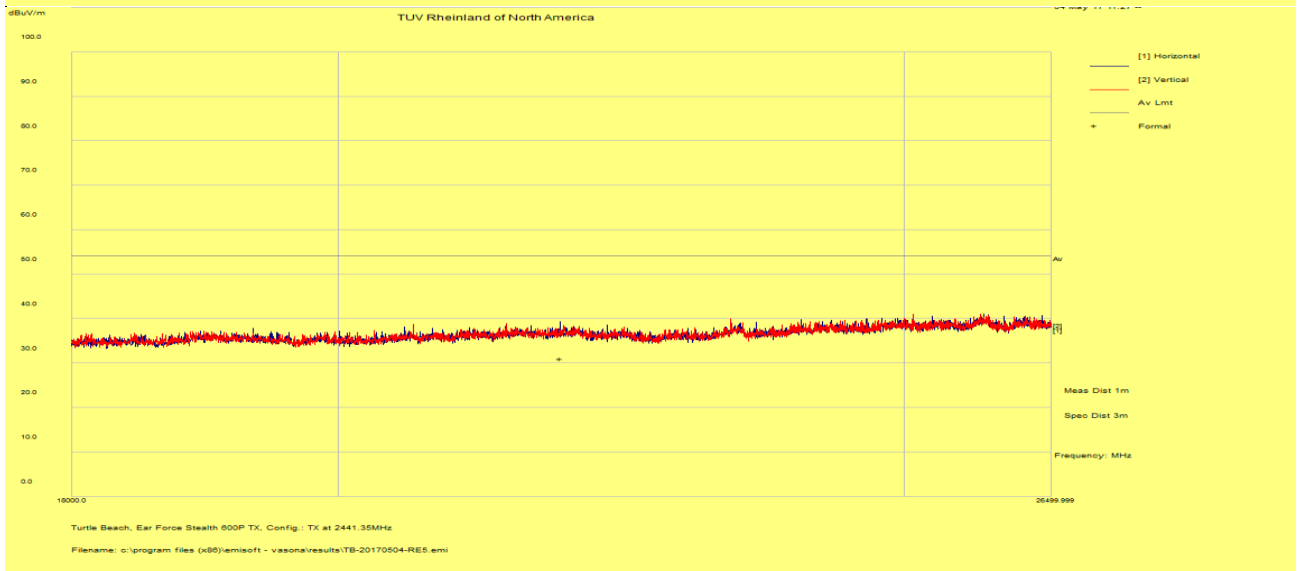
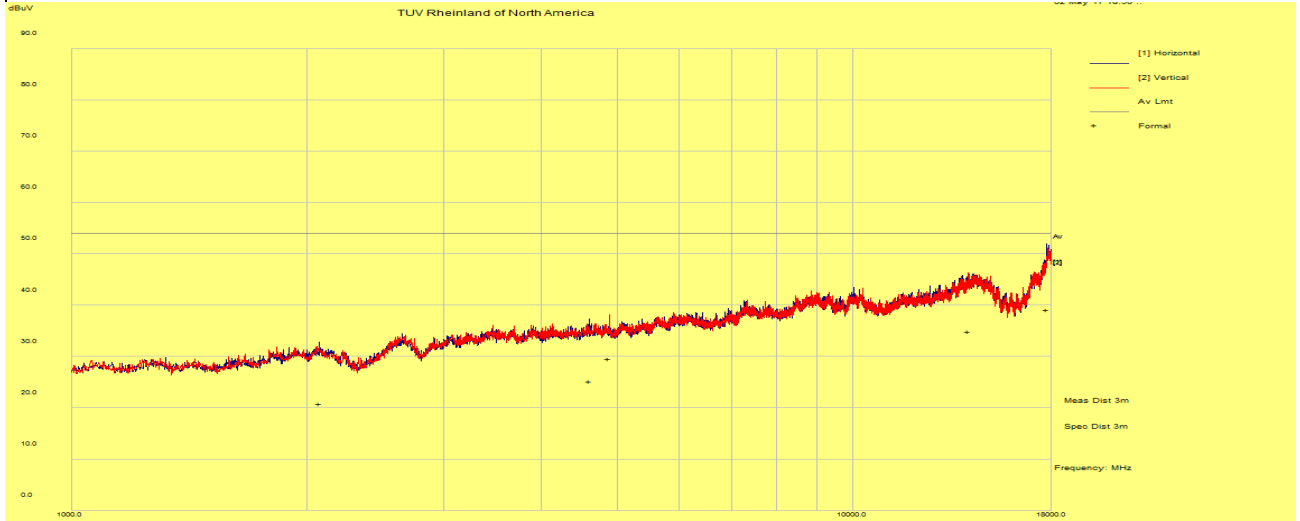

Notes: No emission was observed from 18 to 26 GHz.

SOP 1 Radiated Emissions

Tracking # 31761757.001 Page 6 of 6

EUT Name	USB Wireless Audio Transmitter	Date	May 4, 2017
EUT Model	Ear Force Stealth 600P TX	Temp / Hum in	23°C / 33%rh
EUT Serial	PP #2	Temp / Hum out	N/A
EUT Config.	Transmitter	Line AC / Freq	5.0 VDC
Standard	CFR47 Part 15 Subpart C	RBW / VBW	1 MHz / 3 MHz
Dist/Ant Used	3m / DRH-118, 1m / RA42-K-F-4B-C	Performed by	Jeremy Luong

Above 1 GHz Plots for Transmit Mode at 2477.35 MHz

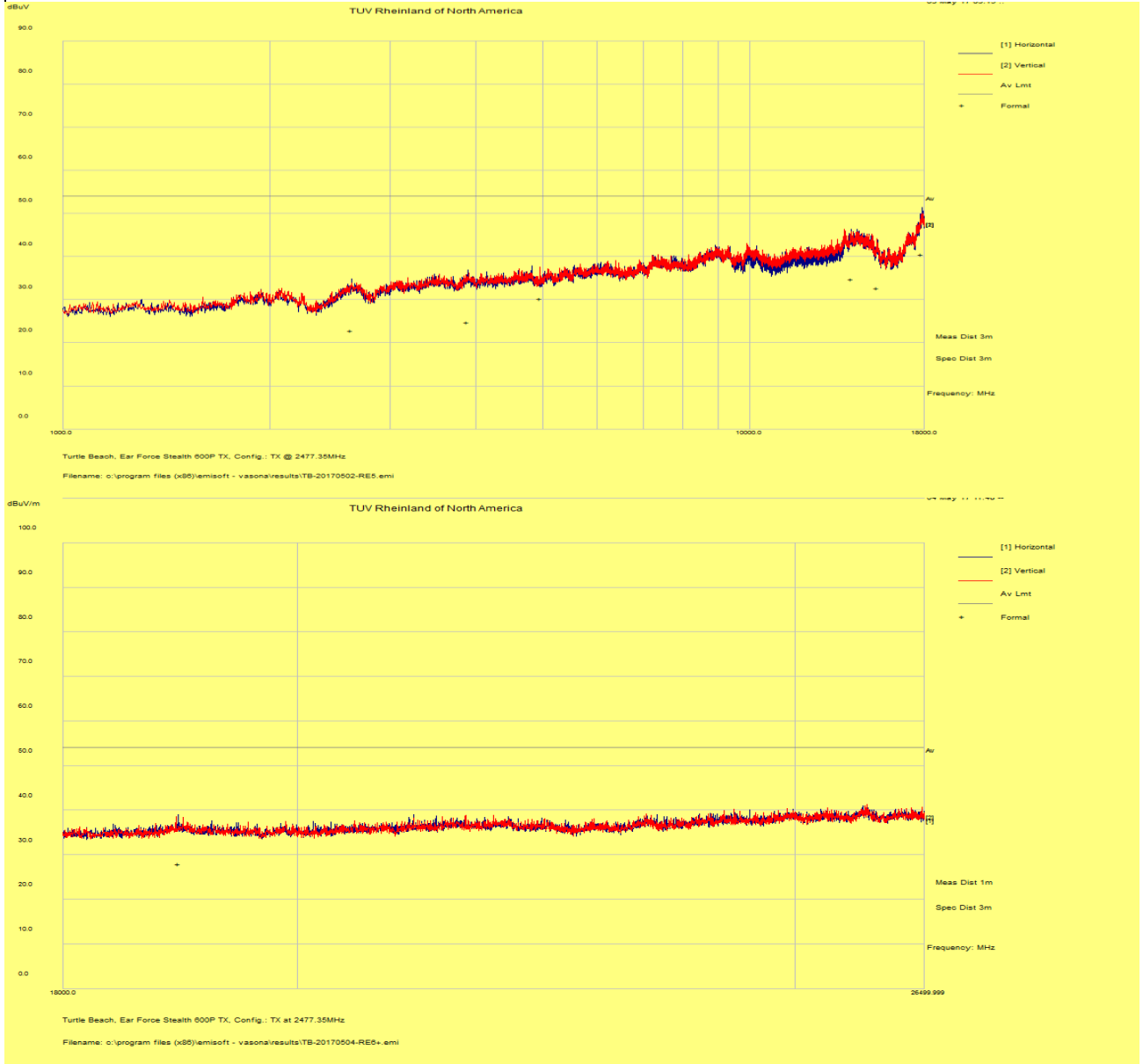

Notes: No emission was observed from 18 to 26 GHz.

4.6.4 Sample Calculation

The field strength is calculated by subtracting the Amplifier Gain and adding the Cable Loss and Antenna Correction Factor to the measured reading. The basic equation is as follows:

$$\text{Field Strength (dB}\mu\text{V/m)} = \text{FIM} - \text{AMP} + \text{CBL} + \text{ACF}$$

Where: FIM = Field Intensity Meter (dB μ V)

AMP = Amplifier Gain (dB)

CBL = Cable Loss (dB)

ACF = Antenna Correction Factor (dB/m)

$$\mu\text{V/m} = 10^{\frac{\text{dB}\mu\text{V/m}}{20}}$$

4.7 AC Conducted Emissions

Testing was performed in accordance with ANSI C63.10: 2013. These test methods are listed under the laboratory's A2LA Scope of Accreditation.

This test measures the levels emanating from the EUT's AC input port, thus evaluating the potential for the EUT to cause radio frequency interference to other electronic devices.

The AC conducted emissions of equipment under test shall not exceed the values in CFR47 Part 15.207: 2017 and RSS Gen: 2017 Sect. 8.8.

4.7.1 Test Methodology

A test program that controls instrumentation and data logging was used to automate the AC Power Line Conducted emission test procedure. The frequency range of interest was divided into sub-ranges such as to yield a frequency resolution of 9 kHz. Each phase and neutral of the AC power line were measured with respect to ground. Measurements were performed using a set of 50µH / 50Ω LISNs.

Testing is performed in Lab 5. The setup photographs clearly identify which site was used. The vertical ground plane used in the semi-anechoic chamber is a 2m x 2m solid aluminum frame and panel, and it is bonded to the horizontal ground plane.

In the case of tabletop equipment, the EUT is placed on a 1.0m x 1.5m non-conductive table 80cm above the ground plane and 40cm from a vertical ground reference plane. The rear of the EUT was positioned flush with the backside of the table and directly over the LISNs. The power and I/O cables were routed over the edge of the table and bundled approximately 40cm from the ground plane. Support equipment was powered from a separate LISN.

4.7.1.1 Deviations

There were no deviations from this test methodology.

4.7.2 Test Results

As originally tested, the EUT was found to be compliant to the requirements of the test standard(s).

Table 7: AC Conducted Emissions – Test Results

Test Conditions: Conducted Measurement		Test Date: May 5, 2017
Antenna Type: Integrated		Power Level: See Test Plan
AC Power: USB Host Computer		Configuration: Tabletop
Ambient Temperature: 23° C		Relative Humidity: 34% RH
Configuration	Frequency Range	Test Result
Line 1 (Hot)	0.15 to 30 MHz	Pass
Line 2 (Neutral)	0.15 to 30 MHz	Pass

SOP 2 Conducted Emissions						Tracking # 31761757.001 Page 1 of 4				
EUT Name	USB Wireless Audio Transmitter					Date	May 5, 2017			
EUT Model	Ear Force Stealth 600P TX					Temp / Hum in	23° C / 35% rh			
EUT Serial	PP #2					Temp / Hum out	N/A			
EUT Config.	Integrated Antenna					Line AC / Freq	120 Vac/60 Hz @ host PC			
Standard	CFR47 Part 15.207					RBW / VBW	9 kHz / 30 kHz			
Lab/LISN	Lab #2 /Com-Power, Line 1					Performed by	Jeremy Luong			
Frequency	Raw	Limiter	Ins. Loss	Level	Detector	Line	Limit	Margin	Result	
MHz	dBuV	dB	dB	dBuV		Line	dBuV	dB		
0.150	41.02	9.82	0.06	50.90	QP	Live	66.00	-15.10	Pass	
0.150	27.60	9.82	0.06	37.48	Ave	Live	56.00	-18.52	Pass	
0.165	38.04	9.82	0.05	47.91	QP	Live	65.21	-17.30	Pass	
0.165	22.32	9.82	0.05	32.19	Ave	Live	55.21	-23.02	Pass	
0.225	32.35	9.83	0.04	42.22	QP	Live	62.64	-20.42	Pass	
0.225	21.66	9.83	0.04	31.53	Ave	Live	52.64	-21.11	Pass	
0.468	22.39	9.84	0.03	32.26	QP	Live	56.55	-24.29	Pass	
0.468	9.88	9.84	0.03	19.75	Ave	Live	46.55	-26.80	Pass	
0.573	30.97	9.85	0.03	40.84	QP	Live	56.00	-15.16	Pass	
0.573	26.67	9.85	0.03	36.55	Ave	Live	46.00	-9.45	Pass	
0.857	23.09	9.87	0.03	32.99	QP	Live	56.00	-23.01	Pass	
0.857	18.35	9.87	0.03	28.25	Ave	Live	46.00	-17.75	Pass	
Spec Margin = QP./Ave. - Limit, ± Uncertainty										
Combined Standard Uncertainty $u_c(y) = \pm 2.18$ dB Expanded Uncertainty $U = ku_c(y)$ $k = 2$ for 95% confidence										
Notes: EUT was setup as table top equipment and transmitted at 2403.35 MHz										

SOP 2 Conducted Emissions

Tracking # 31761757.001 Page 2 of 4

EUT Name	USB Wireless Audio Transmitter	Date	May 5, 2017
EUT Model	Ear Force Stealth 600P TX	Temp / Hum in	23° C / 35% rh
EUT Serial	PP #2	Temp / Hum out	N/A
EUT Config.	Integrated Antenna	Line AC	120 Vac/60 Hz @ PC
Standard	CFR47 Part 15.207	RBW / VBW	9 kHz / 30 kHz
Lab/LISN	Lab #2 /Com-Power, Line 1	Performed by	Jeremy Luong

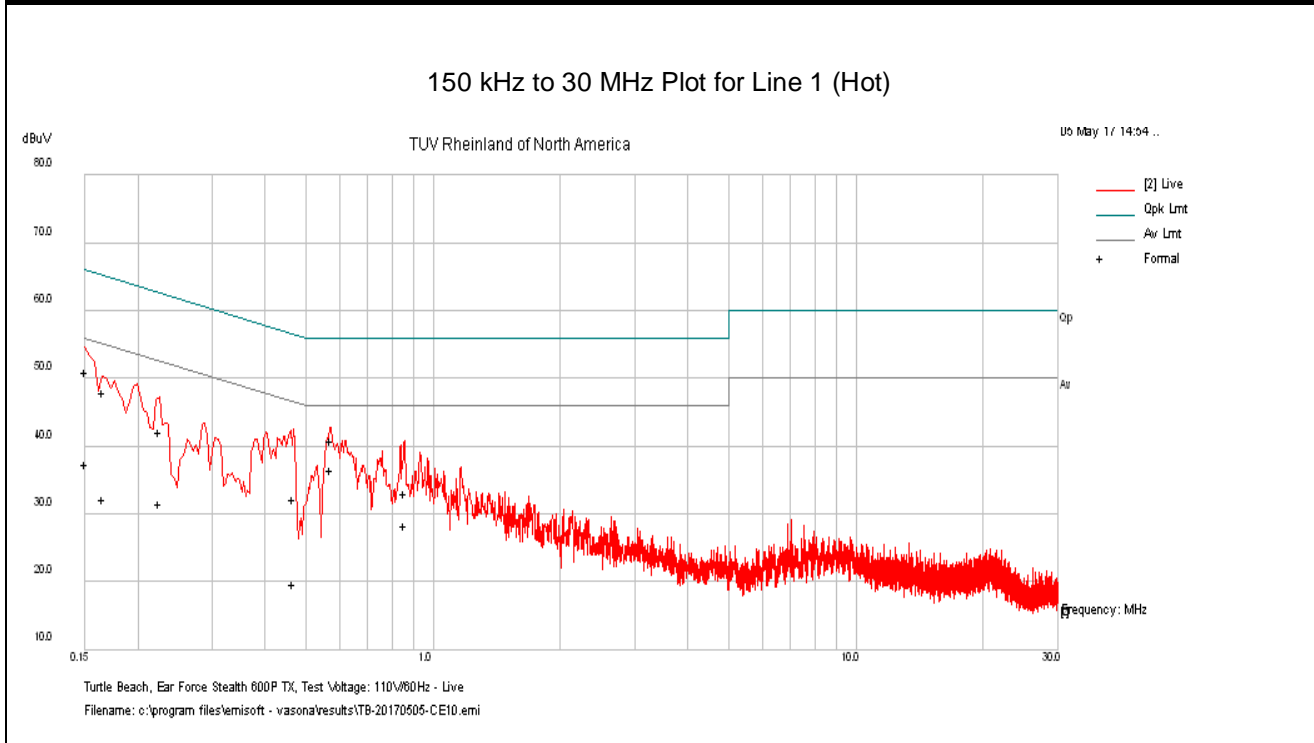

Notes: Meets FCC Class B limit.

SOP 2 Conducted Emissions						Tracking # 31761757.001 Page 3 of 4			
EUT Name	USB Wireless Audio Transmitter				Date	May 5, 2017			
EUT Model	Ear Force Stealth 600P TX				Temp / Hum in	23° C / 35% rh			
EUT Serial	PP #2				Temp / Hum out	N/A			
EUT Config.	Integrated Antenna				Line AC / Freq	120 Vac/60 Hz @ host PC			
Standard	CFR47 Part 15.207				RBW / VBW	9 kHz / 30 kHz			
Lab/LISN	Lab #2 /Com-Power, Line 2				Performed by	Jeremy Luong			
Frequency	Raw	Limiter	Ins. Loss	Level	Detector	Line	Limit	Margin	Result
MHz	dBuV	dB	dB	dBuV		Line	dBuV	dB	
0.154	41.10	9.82	0.06	50.98	QP	Neutral	65.80	-14.82	Pass
0.154	29.65	9.82	0.06	39.53	Ave	Neutral	55.80	-16.27	Pass
0.195	42.33	9.82	0.04	52.20	QP	Neutral	63.83	-11.63	Pass
0.195	29.84	9.82	0.04	39.71	Ave	Neutral	53.83	-14.12	Pass
0.374	31.91	9.84	0.03	41.78	QP	Neutral	58.40	-16.63	Pass
0.374	19.43	9.84	0.03	29.29	Ave	Neutral	48.40	-19.11	Pass
0.404	29.87	9.84	0.03	39.74	QP	Neutral	57.76	-18.03	Pass
0.404	17.26	9.84	0.03	27.13	Ave	Neutral	47.76	-20.63	Pass
0.561	30.29	9.85	0.03	40.17	QP	Neutral	56.00	-15.83	Pass
0.561	17.57	9.85	0.03	27.44	Ave	Neutral	46.00	-18.56	Pass
0.748	27.25	9.86	0.03	37.14	QP	Neutral	56.00	-18.86	Pass
0.748	18.58	9.86	0.03	28.47	Ave	Neutral	46.00	-17.53	Pass
Spec Margin = QP./Ave. - Limit, ± Uncertainty									
Combined Standard Uncertainty $u_c(y) = \pm 2.18$ dB Expanded Uncertainty $U = ku_c(y)$ $k = 2$ for 95% confidence									
Notes: EUT was setup as table top equipment and transmitted at 2403.35 MHz									

SOP 2 Conducted Emissions

Tracking # 31761757.001 Page 4 of 4

EUT Name	USB Wireless Audio Transmitter	Date	May 5, 2017
EUT Model	Ear Force Stealth 600P TX	Temp / Hum in	23° C / 35% rh
EUT Serial	PP #2	Temp / Hum out	N/A
EUT Config.	Integrated Antenna	Line AC / Freq	120 Vac/60 Hz @ PC
Standard	CFR47 Part 15.207	RBW / VBW	9 kHz / 30 kHz
Lab/LISN	Lab #2 /Com-Power, Line 2	Performed by	Jeremy Luong

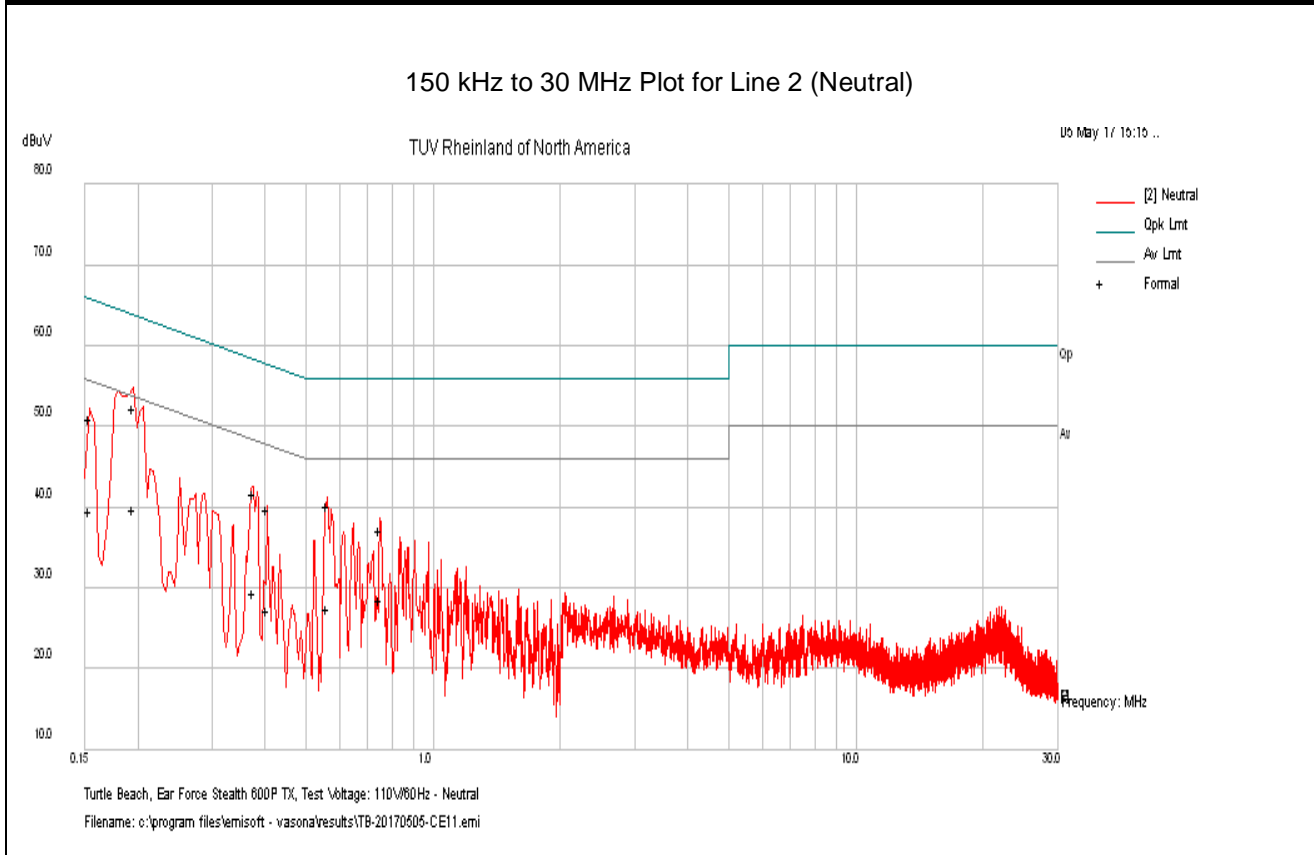

Note: Meets FCC Class B Limit.

5 Test Equipment List

5.1 Equipment List

Equipment	Manufacturer	Model #	Serial/Inst #	Last Cal mm/dd/yyyy	Next Cal mm/dd/yyyy
LISN	Com-Power	LI-215	12111	01/16/2017	01/16/2018
Loop Antenna	EMCO	6502	62531	06/08/2016	06/08/2018
Bilog Antenna	Sunol Sciences	JB3	A102606	06/15/2016	06/15/2018
Horn Antenna	Sunol Sciences	3115	9710-5301	10/08/2015	10/08/2017
Antenna w/ Amplifier	Rohde & Schwarz	TS-PR26	100011	07/11/2017	07/11/2018
Spectrum Analyzer	Rohde & Schwarz	FSL6	100169	01/13/2017	01/13/2018
Spectrum Analyzer	Agilent	N9038A	MY552260210	01/16/2017	01/16/2018
Spectrum Analyzer	Rohde Schwarz	ESIB	832427/002	01/16/2017	01/16/2018
Spectrum Analyzer	Rohde Schwarz	FSV40	1321.3008K40	08/30/2016	08/30/2017
Amplifier	Sonoma Instruments	310	165516	01/19/2017	01/19/2018
Amplifier	Miteq	TTA1800-30-HG	2020728	11/12/2016	11/12/2017
Power Meter	Agilent	E4418B	MY45103902	01/11/2017	01/11/2018
Power Sensor	Hewlett Packard	8482A	1925A04647	01/01/2017	01/01/2018
Thermometer	Fluke	52II	88650033	11/04/2016	11/04/2017
Thermo Chamber	Espec	BTZ-133	0613436	NCR	NCR
DC Power Supply	Agilent	E3634A	MY400004331	01/12/2017	01/12/2018
Notch Filter	Micro-Tronics	BRM50702	37	07/29/2016	07/29/2017
Signal Generator	Anritsu	MG3694A	42803	01/13/2017	01/13/2018
Signal Generator	Rohde & Schwarz	SMF100A	1167.0000K02	09/16/2016	09/16/2017
Signal Generator	Rohde & Schwarz	SMBV100A	1407.6004K02	09/16/2016	09/16/2017
Power Sensors	Rohde & Schwarz	OSP120	1520.9010.02	09/16/2016	09/16/2017

* Calibration of equipment past due for re-calibration will be performed expeditiously. If any equipment is found to be out of tolerance at that time, affected customers will be notified accordingly.

6 EMC Test Plan

6.1 Introduction

This section provides a description of the Equipment Under Test (EUT), configurations, operating conditions, and performance acceptance criteria. It is an overview of information provided by the manufacturer so that the test laboratory may perform the requested testing.

6.2 Customer

Table 7: Customer Information

Company Name	Voyetra Turtle Beach, Inc.
Address	100 Summit Lake Drive, Suite 100
City, State, Zip	Valhalla, New York 10595 USA
Country	USA

Table 8: Technical Contact Information

Name	Tim Blaney
E-mail	tim@commcepts.net
Phone	(530) 277-3482

6.3 Equipment Under Test (EUT)

Table 10: EUT Specifications

EUT Specification	
Package Dimensions	69.85mm (2.75”) x 25.4mm (1.0”) x 9.5mm (0.375”)
Power Input	Transmitter Input Voltage: 5.0 Vdc (Host Computer)
Environment	Indoor
Operating Temperature Range:	0 to 50 degrees C
Multiple Feeds:	<input type="checkbox"/> Yes and how many <input checked="" type="checkbox"/> No
Product Marketing Name (PMN)	Ear Force Stealth 600P TX
Hardware Version Identification Number (HVIN)	Stealth 600P TX
Firmware Version Identification Number (FVIN)	0.2.1
Operating Mode	VMI RF Protocol
Transmitter Frequency Band	2403.35 MHz to 2477.35 MHz
Max. Measured Power Output	1.47 dBm
Power Setting @ Operating Channel	0 dBm
Antenna Type	PCB Attached on board (-0.5 dBi)
Modulation Type	<input type="checkbox"/> AM <input type="checkbox"/> FM <input checked="" type="checkbox"/> DSSS <input type="checkbox"/> OFDM <input type="checkbox"/> Other describe:
Date Rate	11 kbps
TX/RX Chain (s)	1
Directional Gain Type	<input checked="" type="checkbox"/> Uncorrelated <input checked="" type="checkbox"/> No Beam-Forming <input type="checkbox"/> Other describe:
Type of Equipment	<input type="checkbox"/> Table Top <input type="checkbox"/> Wall-mount <input type="checkbox"/> Floor standing cabinet <input checked="" type="checkbox"/> Other describe: <i>Table Top Device's accessory.</i>
Note: None.	

Table 11: Interface Specifications

Interface Type	Cabled with what type of cable?	Is the cable shielded?	Maximum potential length of the cable?	Metallic (M), Coax (C), Fiber (F), or Not Applicable?
USB	Terminated to Host USB	<input checked="" type="checkbox"/> Yes	<input checked="" type="checkbox"/> Metric:3m	<input checked="" type="checkbox"/> M

Table 12: Supported Equipment

Equipment	Manufacturer	Model	Serial	Used for
Laptop	Dell Computer	Latitude E6420	28353268189	Set test mode

Table 13: Description of Sample used for Testing

Device	Serial Number	Configuration	Used For
Ear Force Stealth 600P TX	PP #2	Radiated Sample	Radiated Emissions. Conducted Emission
Ear Force Stealth 600P TX	PP #1	Conducted Sample	Output Power, Occupied Bandwidth, Conducted Spurious Emissions, Peak Power Spectral Density
Note: None			

Table 14: Description of Test Configuration used for Radiated Measurement.

Device	Antenna	Mode	Setup Description
Ear Force Stealth 600P TX	Integrated	Transmit & Receive	Ear Force Stealth 600P TX positioned upright.
Note: This is the final setup configuration used for testing.			

Table 15: Final Test Mode for 2403.35 MHz to 2477.35MHz Band

Test	Ear Force Stealth 520 RX
Occupied Bandwidth	2403.35, 2441.35, 2477.35 MHz @ 11 kbps
Output Power	2403.35, 2441.35, 2477.35 MHz @ 11 kbps
Peak Power Spectral Density	2403.35, 2441.35, 2477.35 MHz @ 11 kbps
Out-of-Band (-30 dBr)	2403.35, 2441.35, 2477.35 MHz @ 11 kbps
Band-Edge (Radiated)	2403.35, 2477.35 MHz @ 11 kbps
Transmitted Spurious Emission	2403.35, 2441.35, 2477.35 MHz @ 11 kbps
AC Conducted Emission	2403.35 MHz @ 11 kbps
Note: EUT transmits at 100% duty cycle.	

6.4 Test Specifications

Table 16: Test Specifications

Emissions and Immunity	
Standard	Requirement
CFR 47 Part 15.247: 2017	All
RSS 247 Issue 2, 2017	All

END OF REPORT