

Emissions Test Report

EUT Name: Wireless Audio Headset

Model No.: Elite 800X RX

CFR 47 Part 15.247:2014 and RSS-210:2010

Prepared for:

Voyetra Turtle Beach, Inc.
100 Summit Lake Drive, Suite 100
Valhalla, New York, 10595 USA

Prepared by:

TUV Rheinland of North America, Inc.
1279 Quarry Lane, Ste. A
Pleasanton, CA 94566 U.S.A.
Tel: (925) 249-9123
Fax: (925) 249-9124
<http://www.tuv.com/>

Report/Issue Date: May 11, 2015
Report Number: 31560640.001
Project Number: 0000126478
Revision Number: 1

Revisions

Revision No.	Date MM/DD/YYYY	Reason for Change	Author
0	04/02/2015	Original Document	N/A
1	05/11/2015	Update Typo on Page 21	Jluong

Note: Latest revision report will replace all previous reports.

Statement of Compliance

Manufacturer: Voyetra Turtle Beach, Inc.
100 Summit Lake Drive, Suite 100
Valhalla, New York, 10595 USA

Requester / Applicant: Tim Blaney

Name of Equipment: Wireless Audio Headset
Model No. Elite 800X RX (TB300-2390-01)
Type of Equipment: Intentional Radiator
Application of Regulations: CFR 47 Part 15.247:2014 and RSS-210:2010
Test Dates: 26 February 2015 to 22 March 2015

Guidance Documents:

Emissions: ANSI C63.10-2009, KDB 558074 D01 DTS Measurement Guidance v03r01

Test Methods:

Emissions: ANSI C63.10-2009, KDB 558074 D01 DTS Measurement Guidance v03r01

The electromagnetic compatibility test and documented data described in this report has been performed and recorded by TUV Rheinland, in accordance with the standards and procedures listed herein. As the responsible authorized agent of the EMC laboratory, I hereby declare that the equipment described above has been shown to be compliant with the EMC requirements of the stated regulations and standards based on these results. If any special accessories and/or modifications were required for compliance, they are listed in the Executive Summary of this report.

This report must not be used to claim product endorsement by A2LA or any agency of the U.S. Government. This report contains data that are not covered by A2LA accreditation. This report shall not be reproduced except in full, without the written authorization of TUV Rheinland of North America.

<u>Jeremy Luong</u>	<u>May 11, 2015</u>	<u>David Spencer</u>	<u>May 11, 2015</u>
Test Engineer	Date	Laboratory Signature	Date



Testing Cert #3331.02



US5254



2932M-1

Table of Contents

1	Executive Summary	7
1.1	Scope	7
1.2	Purpose	7
1.3	Summary of Test Results	8
1.4	Special Accessories	8
1.5	Equipment Modifications	8
2	Laboratory Information	9
2.1	Accreditations & Endorsements	9
2.1.1	US Federal Communications Commission	9
2.1.2	NIST / A2LA	9
2.1.3	Canada – Industry Canada	9
2.1.4	Japan – VCCI	9
2.1.5	Acceptance by Mutual Recognition Arrangement	9
2.2	Test Facilities	10
2.2.1	Emission Test Facility	10
2.2.2	Immunity Test Facility	10
2.3	Measurement Uncertainty	11
2.3.1	Sample Calculation – radiated & conducted emissions	11
2.3.2	Measurement Uncertainty Emissions	11
2.3.3	Measurement Uncertainty Immunity	12
2.4	Calibration Traceability	12
3	Product Information	13
3.1	Product Description	13
3.2	Equipment Configuration	13
3.3	Operating Mode	13
3.4	Unique Antenna Connector	14
3.4.1	Results	14
4	Emission Requirements – 2400 MHz to 2483.5 MHz Band	15
4.1	Output Power Requirements	15
4.1.1	Test Method	15
4.1.2	Results	16
4.2	Occupied Bandwidth	21
4.2.1	Test Method	21
4.2.2	Results	22
4.3	Hopping Frequency Requirements	27
4.3.1	Results	27
4.4	Out of Band Emission requirements	32
4.4.1	Results	32
4.5	Transmitter Spurious Emissions	37
4.6.1	Test Methodology	37

Table of Contents

4.6.2	Transmitter Spurious Emission Limit	38
4.6.3	Test Results	38
4.6.4	Sample Calculation	54
4.2	AC Conducted Emissions	55
4.2.1	Test Methodology	55
4.2.2	Test Results	55
4.3	Maximum Permissible Exposure	56
4.3.1	Test Methodology	56
4.3.2	FCC KDB 447498 D01 – General SAR Test Exclusion Guidance	56
4.3.3	EUT Operating Condition	56
4.3.4	Classification	57
4.3.5	SAR Test Exclusion Threshold	57
6	Test Equipment Use List	58
6.1	Equipment List	58
7	EMC Test Plan	59
7.1	Introduction	59
7.2	Customer	59
7.3	Equipment Under Test (EUT)	60
7.4	Test Specifications	63

Index of Tables

Table 1: Summary of Test Results 8
Table 2: RF Output Power at the Antenna Port – Test Results 16
Table 3: Occupied Bandwidth – Test Results 22
Table 4: Frequency Hopping Requirements 27
Table 5: Band Edge Requirements – Test Results 32
Table 6: Transmit Spurious Emission at Restricted Band Edge Requirements 39
Table 7: Customer Information 59
Table 8: Technical Contact Information 59
Table 9: EUT Specifications 60
Table 10: Interface Specifications 60
Table 11: Supported Equipment 61
Table 12: Description of Sample used for Testing 61
Table 13: Description of Test Configuration used for Radiated Measurement. 61
Table 14: Final Test Mode for 2402 MHz to 2480MHz Channels 62
Table 15: Test Specifications 63

1 Executive Summary

1.1 Scope

This report is intended to document the status of conformance with the requirements of the CFR 47 Part 15.247:2014 and RSS-210:2010 based on the results of testing performed on 26 February 2015 to 22 March 2015 on the Wireless Audio Headset Model Elite 800X RX manufactured by Voyetra Turtle Beach, Inc. This report only applies to the specific samples tested under the stated test conditions. It is the responsibility of the manufacturer to assure that additional production units of this model are manufactured with identical or EMI equivalent electrical and mechanical components. This report is further intended to document changes and modifications to the EUT throughout its life cycle. All documentation will be included as a supplement.

1.2 Purpose

Testing was performed to evaluate the EMC performance of the EUT in accordance with the applicable requirements, procedures, and criteria defined in the application of regulations and application of standards listed in this report.

The report documents the 2.4GHz radio characteristics for the Elite 800X RX.

1.3 Summary of Test Results

Table 1: Summary of Test Results

Test	Test Method ANSI C63.4:2003/ ANSI C63.10:2009	Test Parameters	Measured Value	Result
2402 MHz to 2480 MHz Band				
Spurious Emission in Transmitted Mode	CFR47 15.209, RSS-GEN Sect.7.2.3	Class B	-2.07 dB (Margin)	Complied
Restricted Bands of Operation	CFR47 15.205, RSS 210 Sect.2.6	Class B		Complied
AC Power Conducted Emission	CFR47 15.207, RSS-GEN Sect.7.2.2	N/A	Na.	N/A
Occupied Bandwidth	CFR 47 15.247(a1), RSS Gen Sect. 4.4.1	N/A	20dB BW = 774 kHz 99% BW = 838 kHz	Complied
Channel Separation	CFR47 15.247 (a1), RSS 210 Sect. A.8.1	> 828 kHz	1012 kHz	Complied
Number of Hopping Channels	CFR47 15.247 (a1), RSS 210 Sect. A.8.1	>15	79 Channels	Complied
Average time occupancy of Channel	CFR47 15.247 (a1), RSS 210 Sect. A.8.1	< 0.4 sec	320.76 mS	Complied
Maximum Transmitted Power	CFR47 15.247 (b1), RSS 210 Sect. A.8.1	< 1Watt	2.84 mW	Complied
Out of Band Emission	CFR47 15.247 (d), RSS 210 Sect. A.8.5	< -20 dBr	- 17.95 dBr (-47.74 dBm at 4960 MHz)	Complied
Maximum Permissible Exposure	CFR47 15.247 (i), 2.1093 / KDB 447498 D01	≤ 3.0 for 1-g	0.427 for 1-g (SAR Exempted)	Complied

Note: 1. Meet restricted band emission requirements.
 2. This report is only documented for 2402 – 2480MHz.

1.4 Special Accessories

No special accessories were necessary in order to achieve compliance.

1.5 Equipment Modifications

None

2 Laboratory Information

2.1 Accreditations & Endorsements

2.1.1 US Federal Communications Commission



TUV Rheinland of North America at 1279 Quarry Ln, Pleasanton, CA 94566 is recognized by the commission for performing testing services for the general public on a fee basis. These laboratory test facilities have been fully described in reports submitted to and accepted by the FCC (US5254). The laboratory scope of accreditation includes: Title 47 CFR Parts 15, 18, and 90. The accreditation is updated every 3 years.

2.1.2 NIST / A2LA



TUV Rheinland of North America is accredited by the National Voluntary Laboratory Accreditation Program, which is administered under the auspices of the National Institute of Standards and Technology. The laboratory has been assessed and accredited in accordance with ISO Guide 17025:2005 and ISO 9002 (Lab Code 3331.02). The scope of laboratory accreditation includes emission and immunity testing. The accreditation is updated annually.

2.1.3 Canada – Industry Canada



TUV Rheinland of North America at the 1279 Quarry Ln, Pleasanton, CA 94566 address is accredited by Industry Canada for performing testing services for the general public on a fee basis. This laboratory test facilities have been fully described in reports submitted to and accepted by Industry Canada (File Number 2932M). This reference number is the indication to the Industry Canada Certification Officers that the site meets the requirements of RSS 212, Issue 1 (Provisional). The accreditation is updated every 3 years.

2.1.4 Japan – VCCI



The Voluntary Control Council for Interference by Information Technology Equipment (VCCI) is a group that consists of Information Technology Equipment (ITE) manufacturers and EMC test laboratories. The purpose of the Council is to take voluntary control measures against electromagnetic interference from Information Technology Equipment, and thereby contribute to the development of a socially beneficial and responsible state of affairs in the realm of Information Technology Equipment in Japan. TUV Rheinland of North America at 1279 Quarry Ln, Pleasanton, CA 94566 has been assessed and approved in accordance with the Regulations for Voluntary Control Measures.

VCCI Registration No. for Pleasanton: A-0031

VCCI Registration No. for Santa Clara: A-0032

2.1.5 Acceptance by Mutual Recognition Arrangement

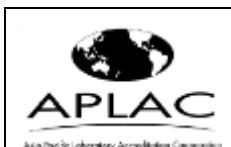

The United States has an established agreement with specific countries under the Asia Pacific Laboratory Accreditation Corporation (APLAC) Mutual Recognition Arrangement. Under this agreement, all TUV Rheinland at 1279 Quarry Ln, Pleasanton, CA 94566 test results and test reports within the scope of the laboratory NIST / A2LA accreditation will be accepted by each member country.

2.2 Test Facilities

All of the test facilities are located at 1279 Quarry Lane, Pleasanton, California 94566, USA. The 2305 Mission College, Santa Clara, 95054, USA location is considered a Pleasanton annex.

2.2.1 Emission Test Facility

The Semi-Anechoic chamber and AC Line Conducted measurement facility used to collect the radiated and conducted data has been constructed in accordance with ANSI C63.7:1992. The site has been measured in accordance with and verified to comply with the theoretical normalized site attenuation requirements of ANSI C63.4-2009, at a test distance of 3 and 5 meters. The site is listed with the FCC and accredited by A2LA (Lab Code 3331.02). The 3/5-meter semi-anechoic chamber used to collect the radiated data has been verified to comply with the theoretical normalized site attenuation requirements of ANSI C63.4-2009, at a test distance of 3 meter and 5 meters. A report detailing this site can be obtained from TUV Rheinland of North America.

2.2.2 Immunity Test Facility

ESD, EFT, Surge, PQF: These tests are performed in an environmentally controlled room with a 3.7 m x 4.8 m x 3.175 mm thick aluminum floor connected to PE ground.

For ESD testing, tabletop equipment is placed on an insulated mat with a surface resistivity of 10^9 Ohms/square on a 1.6 m x 0.8 m x 0.8 m high non-conductive table with a 3.175 mm aluminum top (Horizontal Coupling Plane). The HCP is connected to the main ground plane via a low impedance ground strap through two 470-k Ω resistors. The Vertical Coupling Plane consists of an aluminum plate 50 cm x 50 cm x 3.175 mm thick. The VCP is connected to the main ground plane via a low impedance ground strap through two 470-k Ω resistors.

For EFT, Surge, PQF, the HCP and VCP are removed.

RF Field Immunity testing is performed in a 7.3m x 4.3m x 4.1m anechoic chamber.

RF Conducted and Magnetic Field Immunity testing is performed on a 4.8m x 3.7m x 3.175mm thick aluminum ground plane.

All test areas allow a minimum distance of 1 meter from the EUT to walls or conducting objects.

2.3 Measurement Uncertainty

Two types of measurement uncertainty are expressed in this report, per *ISO Guide To The Expression Of Uncertainty In Measurement*, 1st Edition, 1995.

The Combined Standard Uncertainty is the standard uncertainty of the result of a measurement when that result is obtained from the values of a number of other quantities; it is equal to the positive square root of the sum of the variances or co-variances of these other quantities, weighted according to how the measurement result varies with changes in these quantities. The term *standard uncertainty* is the result of a measurement expressed as a standard deviation.

2.3.1 Sample Calculation – radiated & conducted emissions

The field strength is calculated by subtracting the Amplifier Gain and adding the Cable Loss and Antenna Correction Factor to the measured reading. The basic equation is as follows:

$$\text{Field Strength (dB}\mu\text{V/m)} = \text{RAW} - \text{AMP} + \text{CBL} + \text{ACF}$$

Where: RAW = Measured level before correction (dB μ V)

AMP = Amplifier Gain (dB)

CBL = Cable Loss (dB)

ACF = Antenna Correction Factor (dB/m)

$$\mu\text{V/m} = 10^{\frac{\text{dB}\mu\text{V/m}}{20}}$$

Sample radiated emissions calculation @ 30 MHz

Measurement +Antenna Factor–Amplifier Gain+Cable loss=Radiated Emissions (dBuV/m)

$$25 \text{ dBuV/m} + 17.5 \text{ dB} - 20 \text{ dB} + 1.0 \text{ dB} = 23.5 \text{ dBuV/m}$$

2.3.2 Measurement Uncertainty Emissions

Per CISPR 16-4-2	U _{lab}	U _{cispr}
Radiated Disturbance @ 10 meters		
30 – 1,000 MHz	2.25 dB	4.51 dB
Radiated Disturbance @ 3 meters		
30 – 1,000 MHz	2.26 dB	4.52 dB
1 – 6 GHz	2.12 dB	4.25 dB
6 – 18 GHz	2.47 dB	4.93 dB
Conducted Disturbance @ Mains Terminals		
150 kHz – 30 MHz	1.09 dB	2.18 dB
Disturbance Power		
30 MHz – 300 MHz	3.92 dB	4.3 dB

Voltech PM6000A

The estimated combined standard uncertainty for harmonic current and flicker measurements is $\pm 5.0\%$.	Per CISPR 16-4-2 Methods
--	--------------------------

2.3.3 Measurement Uncertainty Immunity

The estimated combined standard uncertainty for ESD immunity measurements is $\pm 8.2\%$.	Per IEC 61000-4-2
The estimated combined standard uncertainty for radiated immunity measurements is ± 4.10 dB.	Per IEC 61000-4-3
The estimated combined standard uncertainty for conducted immunity measurements with CDN is ± 3.66 dB	Per IEC 61000-4-6
The estimated combined standard uncertainty for power frequency magnetic field immunity is $\pm 11.6\%$.	Per IEC 61000-4-8

Thermo KeyTek EMC Pro

The estimated combined standard uncertainty for EFT fast transient immunity measurements is $\pm 5.84\%$.
The estimated combined standard uncertainty for surge immunity measurements is $\pm 5.84\%$.
The estimated combined standard uncertainty for voltage variation and interruption measurements is $\pm 3.48\%$.

The expanded uncertainty at a level of 95% confidence is obtained by multiplying the combined standard uncertainty by a coverage factor of 2. Compliance criteria are not based on measurement uncertainty.

Measurement Uncertainty – Radio Testing

The estimated combined standard uncertainty for frequency error measurements is ± 3.88 Hz
The estimated combined standard uncertainty for carrier power measurements is ± 1.59 dB.
The estimated combined standard uncertainty for adjacent channel power measurements is ± 1.47 dB.
The estimated combined standard uncertainty for modulation frequency response measurements is ± 0.46 dB.
The estimated combined standard uncertainty for transmitter conducted emission measurements is ± 4.01 dB

The expanded uncertainty at a level of 95% confidence is obtained by multiplying the combined standard uncertainty by a coverage factor of 2. Compliance criteria are not based on measurement uncertainty.

2.4 Calibration Traceability

All measurement instrumentation is traceable to the National Institute of Standards and Technology (NIST). Measurement method complies with ANSI/NCSL Z540-1-1994 and ISO Standard 17025:2005.

3 Product Information

3.1 Product Description

The Elite 800X Wireless Gaming System consists of two main communication modules, the Elite 800X RX (“Headset”) and the Elite 800X TX (“Transmitter”). These two modules comprise a closed-loop wireless audio gaming system that utilize a Wi-Fi communication technology to offer wireless streaming audio and chat/talkback capabilities. The Elite 800X RX (“Headset”) has an additional Bluetooth feature supporting the mobile configuration.

3.2 Equipment Configuration

A description of the equipment configuration is given in the Test Plan Section. The EUT was tested as called for in the test standard and was configured and operated in a manner consistent with its intended use. The EUT was connected to rated power and allowed to reach intended operating conditions. The placement of the EUT system components was guided by the test standard and selected to represent typical installation conditions.

In the case of a EUT that can operate in more than one configuration, preliminary testing was performed to determine the configuration that produced maximum radiation.

The final configuration was selected to produce the worst case radiation for emissions testing and to place the EUT in the most susceptible state for immunity testing.

3.3 Operating Mode

A description of the operation mode is given in the Test Plan Section. In the case of a EUT that can operate in more than one state, preliminary testing was performed to determine the operating mode that produced maximum radiation.

The final operating mode was selected to produce the worst case radiation for emissions testing and to place the EUT in the most susceptible state for immunity testing.

3.4 Unique Antenna Connector

An intentional radiator shall be designed to ensure that no antenna other than that furnished by the responsible party shall be used with the device. The use of a permanently attached antenna or of an antenna that uses a unique coupling to the intentional radiator shall be considered sufficient to comply with the provisions of this Section. The manufacturer may design the unit so that a broken antenna can be replaced by the user, but the use of a standard antenna jack or electrical connector is prohibited. This requirement does not apply to carrier current devices or to devices operated under the provisions of CFR47 Parts 15.211, 15.213, 15.217, 15.219, or 15.221.

3.4.1 Results

The Elite 800X RX uses the permanently attached PCB trace antennas inside the device. See EUT Photo for details. There is no external antenna connection available.

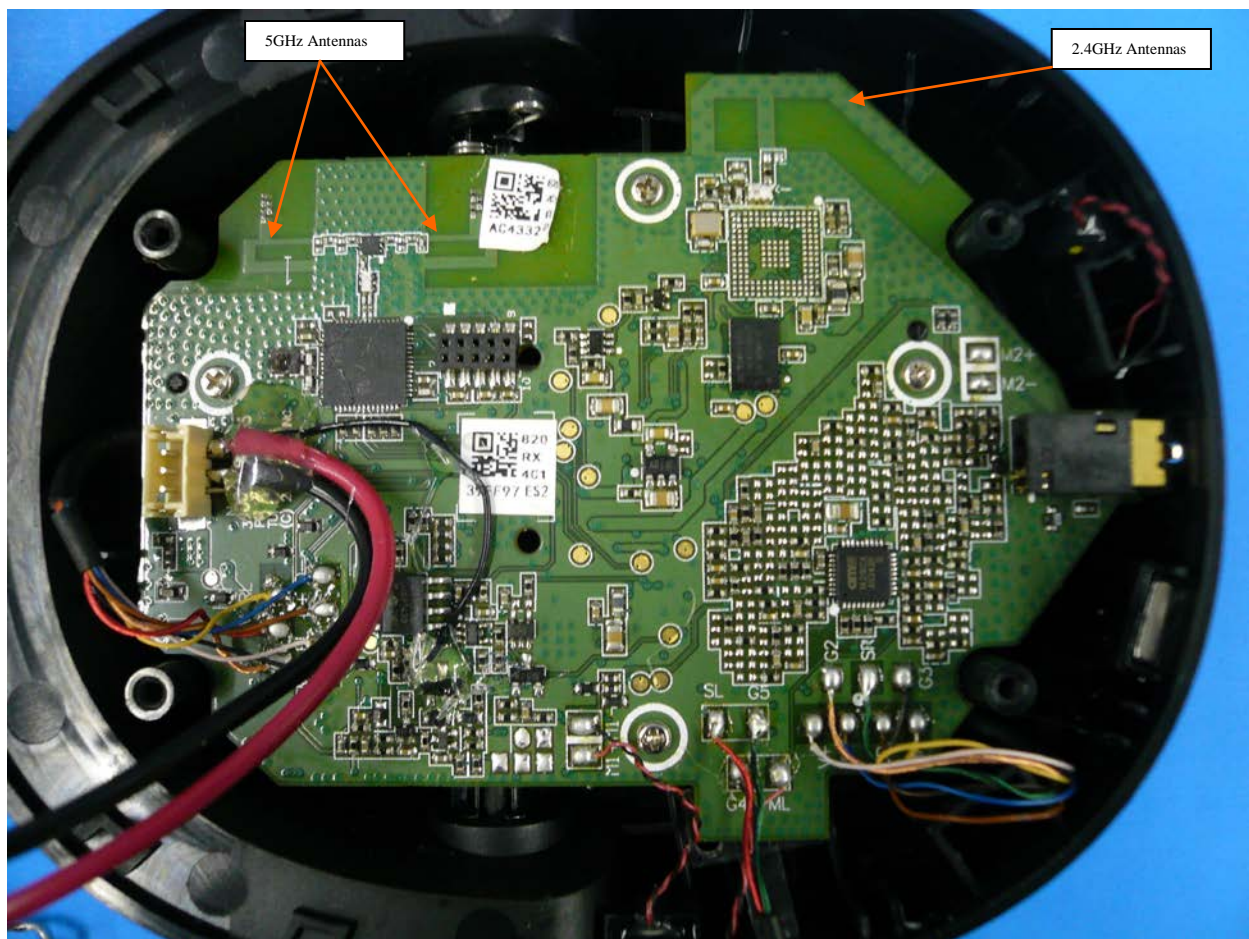

4 Emission Requirements – 2400 MHz to 2483.5 MHz Band

Testing was performed in accordance with CFR 47 Part 15.247: 2014 and RSS 210 Annex 8: 2010. These test methods are listed under the laboratory's A2LA Scope of Accreditation. This test measures the levels emanating from the EUT, thus evaluating the potential for the EUT to cause radio frequency interference to other electronic devices. Procedures described in Section 8 of the standard were used.

4.1 Output Power Requirements

The maximum output power requirement is the maximum equivalent isotropic radiated power delivering at the transmitting antenna under specified conditions of measurements in the presence of modulation.

The maximum output power and harmonics shall not exceed CFR47 Part 15.247 (b1) and RSS 210 A.8.1: 2010

Frequency hopping systems in the 2400-2483.5 MHz band: 1 watts.

4.1.1 Test Method

The conducted method was used to measure the channel power output according to ANSI C63.10:2009 Section 6.10.3.1. The measurement was performed with modulation per CFR47 Part 15.247 (b 1):2014 and RSS 210 A.8.1. This test was conducted on 3 channels on Elite 800X RX, SN: PP #1. The worst mode result indicated below.

Test Setup:

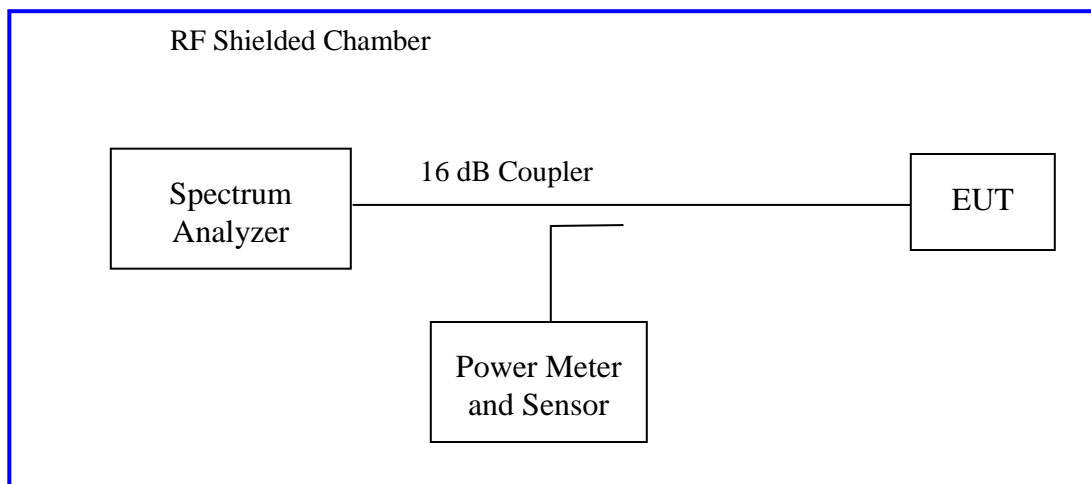

4.1.2 Results

As originally tested, the EUT was found to be compliant to the requirements of the test standard(s).

Table 2: RF Output Power at the Antenna Port – Test Results

Test Conditions: Conducted Measurement, Normal Temperature		Date: January 27, 2015		
Antenna Type: Integrated Antenna		Power Setting: 46/ 48		
Max. Antenna Gain: 2.8 dBi		Signal State: Modulated		
Duty Cycle: 100 %		Data Rate: BDR and EDR		
Ambient Temp.: 23° C		Relative Humidity: 28 %RH		
802.15.1 Mode				
Package/ Power	Operating Channel	Limit [dBm]	Power [dBm]	Margin [dB]
DH1/ 46	2402 MHz	+30.00	3.84	-26.16
	2442 MHz	+30.00	3.53	-26.47
	2480 MHz	+30.00	2.42	-25.46
DH3/ 48	2402 MHz	+30.00	2.93	-27.07
	2442 MHz	+30.00	2.64	-27.36
	2480 MHz	+30.00	3.28	-25.85
DH5/ 48	2402 MHz	+30.00	4.54	-25.46
	2442 MHz	+30.00	3.28	-26.72
	2480 MHz	+30.00	3.25	-26.75
2-DH1/ 46	2402 MHz	+30.00	3.15	-26.85
	2442 MHz	+30.00	2.60	-27.4
	2480 MHz	+30.00	1.47	-28.53
2-DH3/ 48	2402 MHz	+30.00	3.95	-26.05
	2442 MHz	+30.00	3.40	-26.6
	2480 MHz	+30.00	2.21	-27.79
2-DH5/ 48	2402 MHz	+30.00	3.96	-26.04
	2442 MHz	+30.00	3.39	-26.61
	2480 MHz	+30.00	2.26	-27.74

3-DH1/ 46	2402 MHz	+30.00	3.36	-26.64
	2442 MHz	+30.00	3.47	-26.53
	2480 MHz	+30.00	1.63	-28.37
3-DH3/ 48	2402 MHz	+30.00	4.04	-25.96
	2442 MHz	+30.00	3.47	-26.53
	2480 MHz	+30.00	2.32	-27.68
3-DH5/ 48	2402 MHz	+30.00	3.97	-26.03
	2442 MHz	+30.00	3.43	-26.57
	2480 MHz	+30.00	2.31	-27.69
<p>Note: The headset is capable to transmit at both BDR and EDR. The worst case at low, middle, and high frequencies are showed below.</p>				

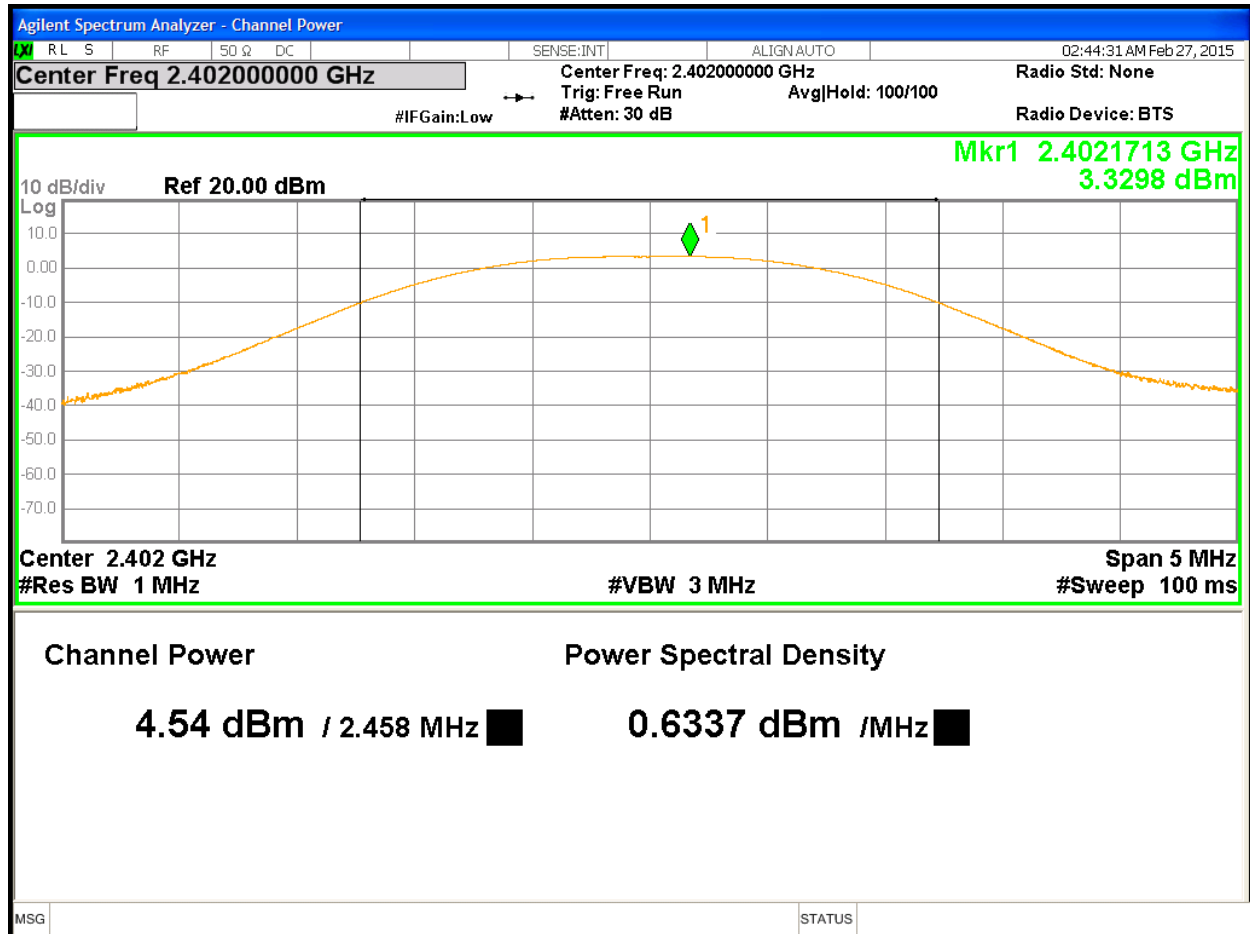

Figure 1: Maximum Transmitted Power, 2402 MHz

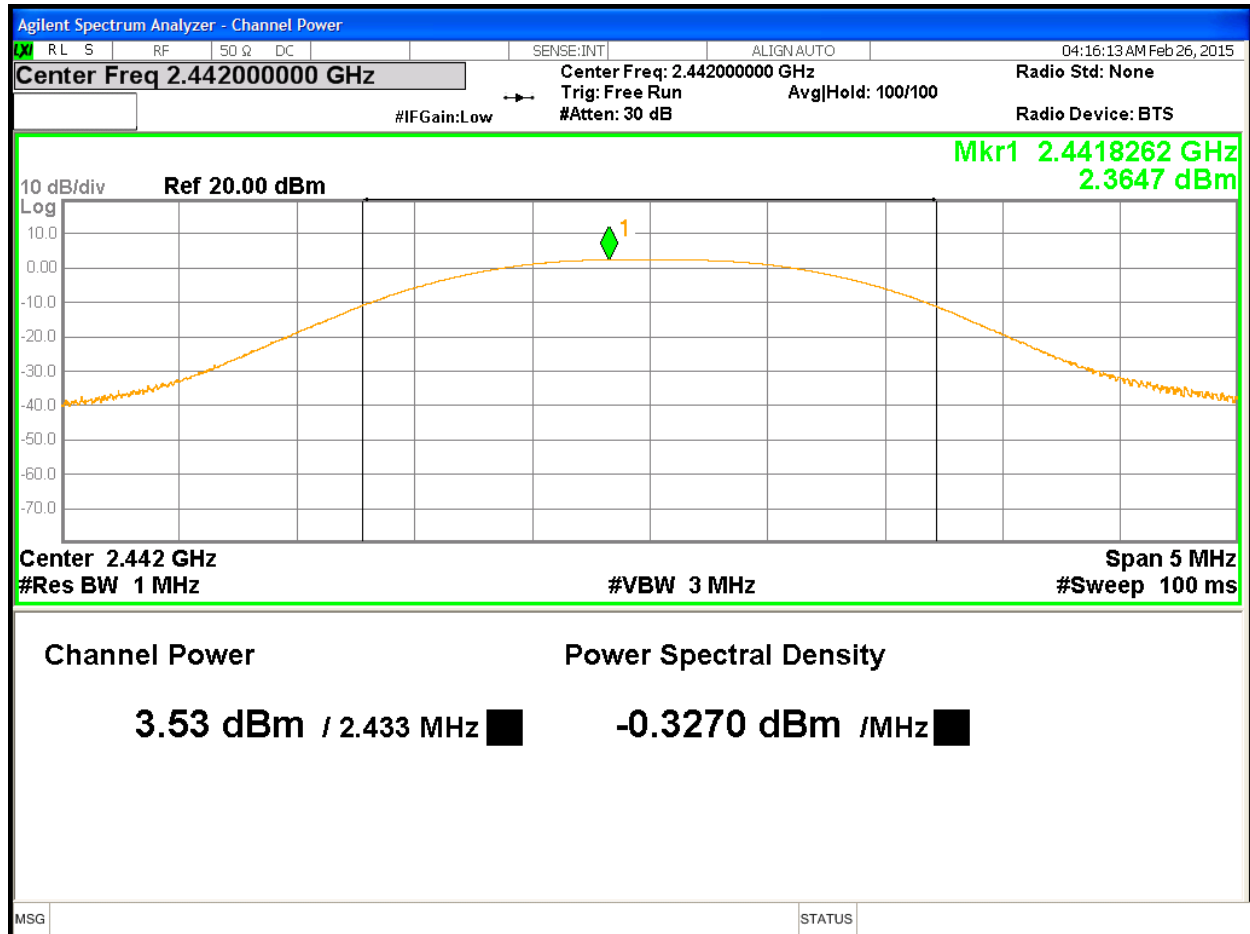

Figure 2: Maximum Transmitted Power, 2442 MHz

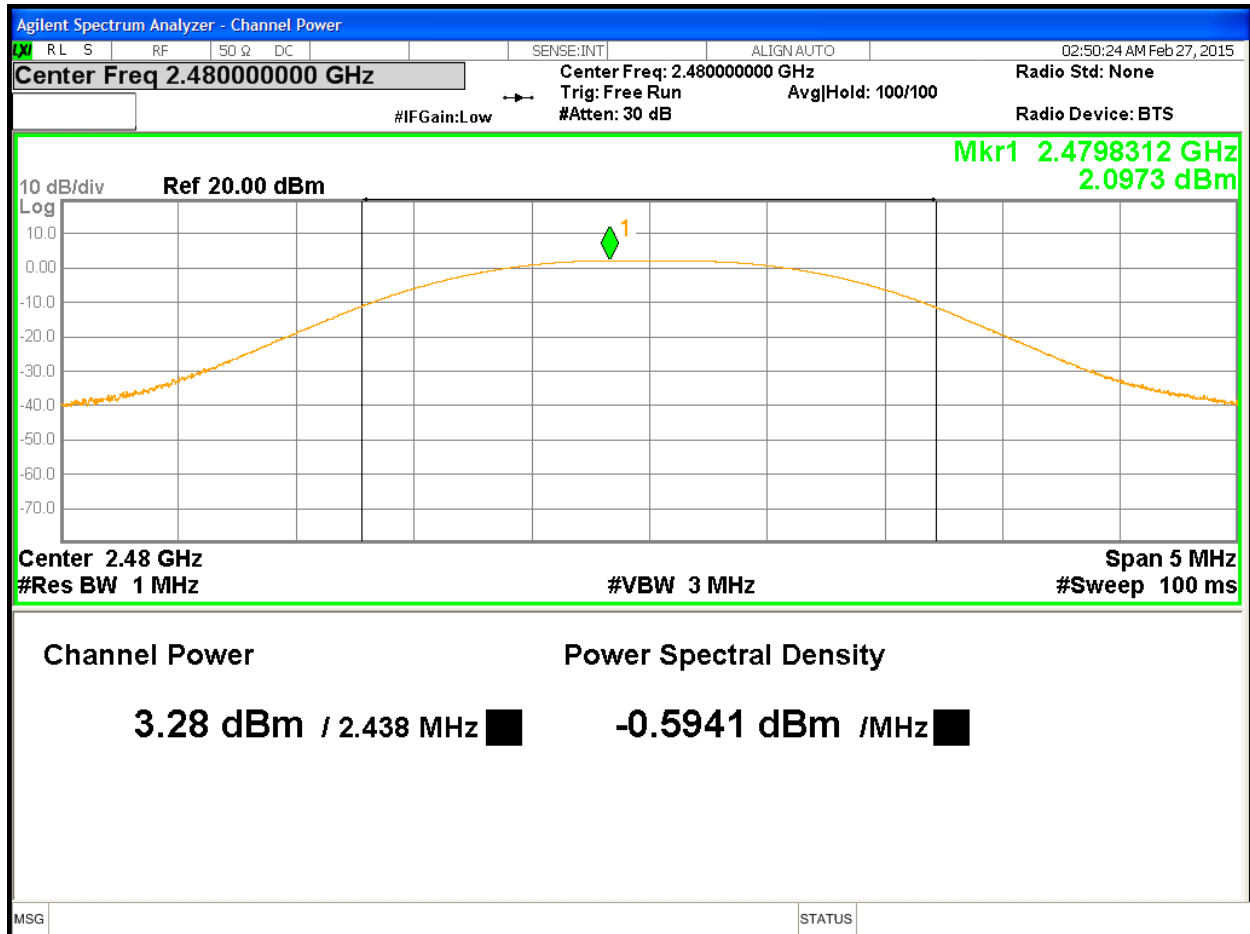

Figure 3: Maximum Transmitted Power, 2480 MHz

4.2 Occupied Bandwidth

The occupied bandwidth is measured at an amplitude level reduced from the reference level by a specified ratio. The reference level is the level of the highest amplitude signal observed from the transmitter at the fundamental frequency.

The 99% bandwidth is the bandwidth in which 99% of the transmitted power occupied.

20 dB bandwidth was performed by coupling the output of the EUT to the input of a spectrum analyzer.

4.2.1 Test Method

The conducted method was used to measure the occupied bandwidth. The measurement was performed with modulation per CFR47 15.247(a) (1) 2014 and RSS Gen Sect. 4.4.1:2010. This test was conducted on 3 channels on Elite 800X RX, SN: PP #1. The worst sample result indicated below.

Test Setup:

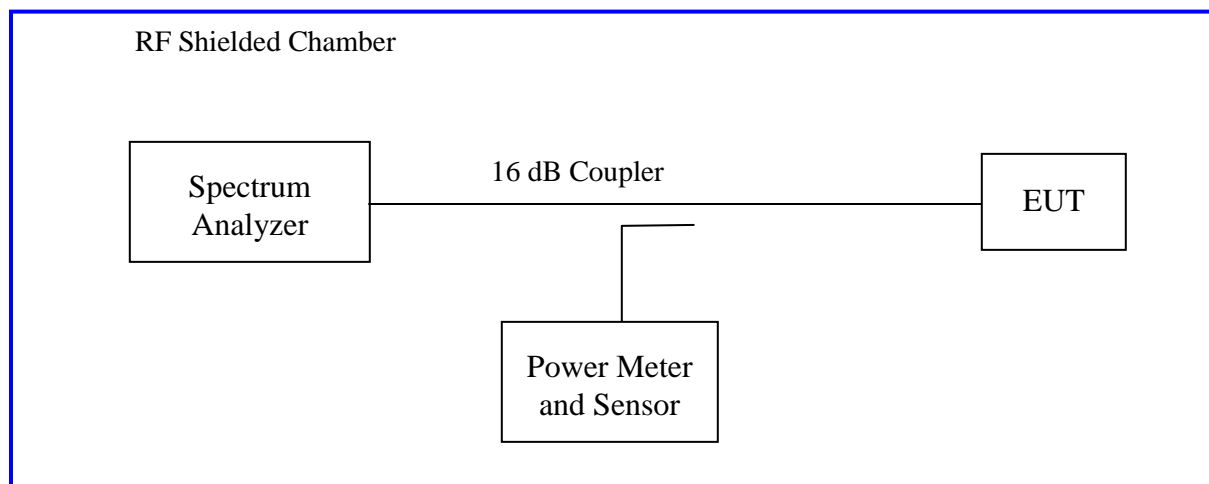

4.2.2 Results

These measurements were used for information only

Table 3: Occupied Bandwidth – Test Results

Test Conditions: Conducted Measurement, Normal Temperature and Voltage only		Date: February 26, 2015	
Antenna Type: Integrated Antenna		Power Setting: Fixed.	
Max. Antenna Gain: +2.8 dBi		Signal State: Modulated	
Duty Cycle: 100 %		Data Rate: see below	
Ambient Temp.: 23° C		Relative Humidity: 28 %RH	
Bandwidth (MHz)			
Package/ Power	Freq. (MHz)	20dB Bandwidth MHz	99% Bandwidth MHz
DH1/ 46	2402	0.774	0.838
	2442	0.778	0.838
	2480	0.778	0.837
DH3/ 48	2402	0.845	0.844
	2442	0.856	0.845
	2480	0.854	0.844
DH5/ 48	2402	0.855	0.859
	2442	0.855	0.857
	2480	0.856	0.854
2-DH1/ 46	2402	1.185	1.163
	2442	1.191	1.164
	2480	1.190	1.163
2-DH3/ 48	2402	1.216	1.184
	2442	1.219	1.179
	2480	1.221	1.174
2-DH5/ 48	2402	1.207	1.184

	2442	1.228	1.178
	2480	1.220	1.173
3-DH1/ 46	2402	1.192	1.150
	2442	1.191	1.150
	2480	1.192	1.148
3-DH3/ 48	2402	1.242	1.181
	2442	1.244	1.185
	2480	1.244	1.183
3-DH5/ 48	2402	1.242	1.180
	2442	1.245	1.185
	2480	1.245	1.178
Note: Worst case for frequency range is plotted below.			

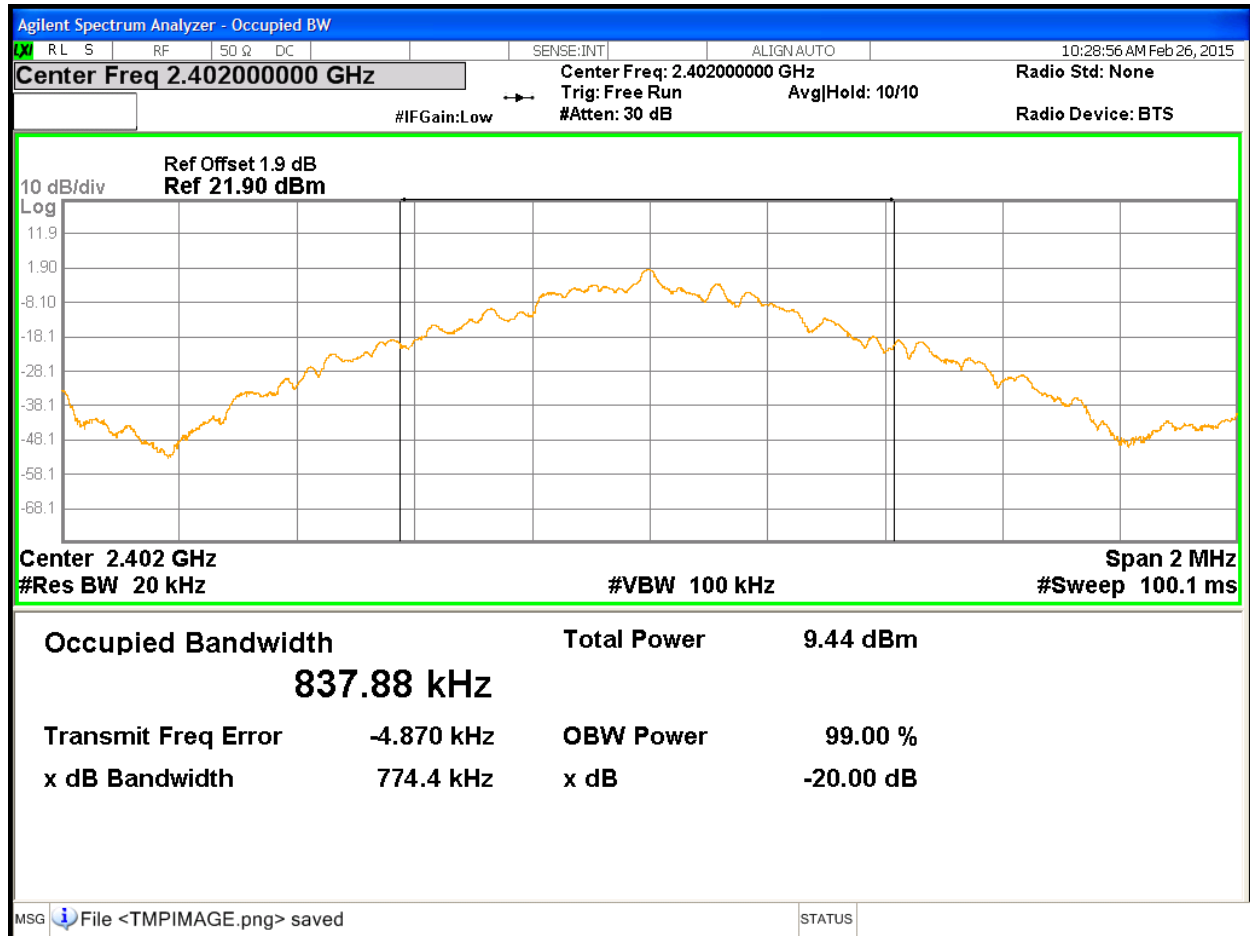

Figure 4: Occupied Bandwidth at 2402 MHz

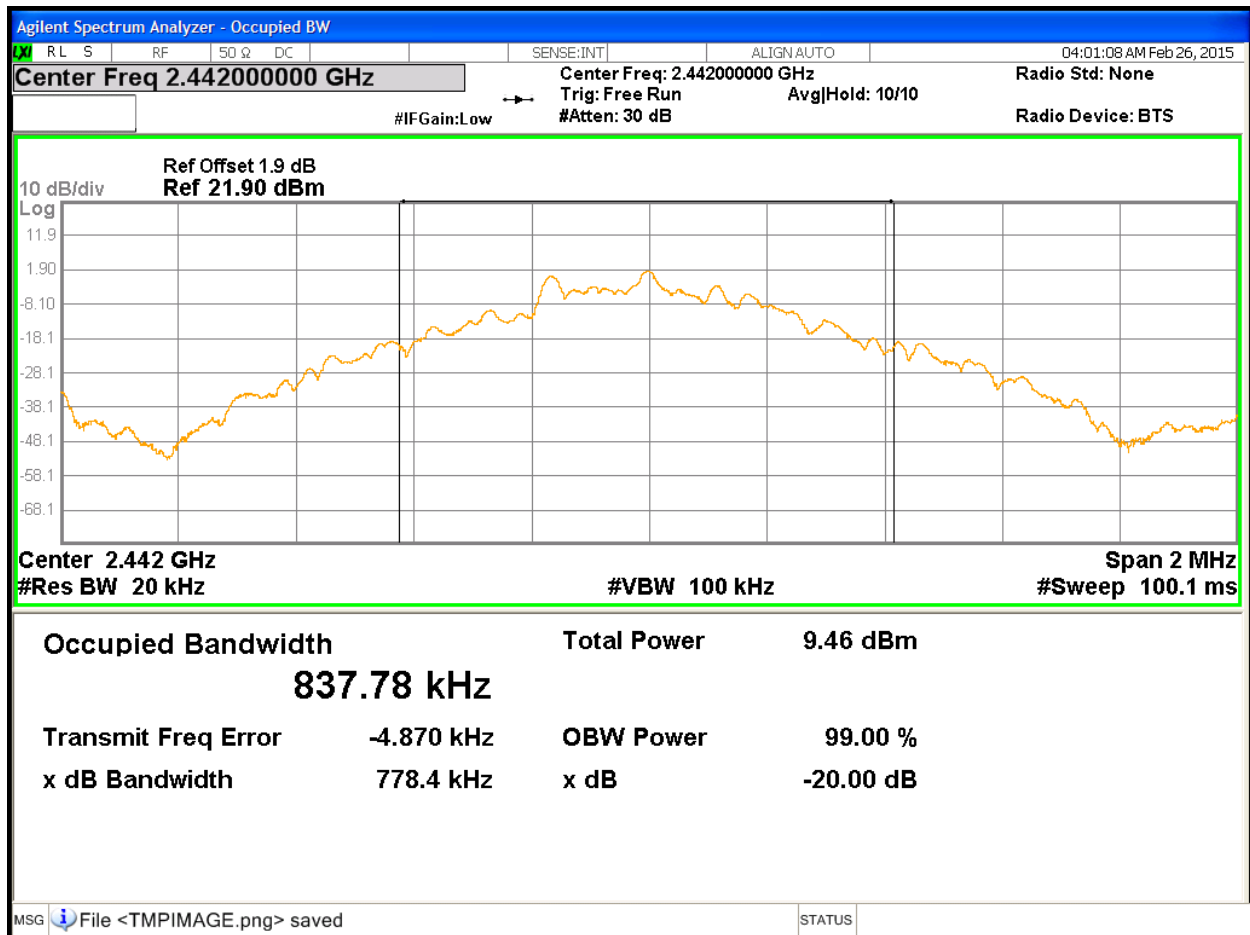

Figure 5: Occupied Bandwidth at 2441 MHz



Figure 6: Occupied Bandwidth at 2480 MHz

4.3 Hopping Frequency Requirements

The Frequency Hopping Requirements are applicable to the equipment using Frequency Hopping Spread Spectrum (FHSS) modulation.

Per CFR47 15.247 (a1), RSS 210 Sect.A.8.1.2, frequency hopping systems in the 2400–2483.5 MHz band shall use at least 15 channels. The average time of occupancy on any channel shall not be greater than 0.4 seconds within a period of 0.4 seconds multiplied by the number of hopping channels employed.

Frequency hopping systems shall have hopping channel carrier frequencies separated by a minimum of 25 kHz or the 20 dB bandwidth of the hopping channel, whichever is greater. Alternatively, frequency hopping systems operating in the 2400-2483.5 MHz band may have hopping channel carrier frequencies that are separated by 25 kHz or two-thirds of the 20 dB bandwidth of the hopping channel, whichever is greater, provided the systems operate with an output power no greater than 125 mW.

The setup was identical to RF output power measurement.

4.3.1 Results

As originally tested, the EUT was found to be compliant to the requirements of the test standard(s).

Table 4: Frequency Hopping Requirements

Test Conditions: Conducted Measurement, Normal Temperature and Voltage only			Date: March 22, 2015		
Antenna Type: Integrated Antenna			Power Setting: 46/ 48		
Max. Antenna Gain: +2.8 dBi			Signal State: Modulated		
Duty Cycle: 100 %			Data Rate: BDR and EDR		
Ambient Temp.: 23° C			Relative Humidity: 33 %RH		
Average Occupancy Time					
Package/ Power	Pulse Width (ms)	# of Pulses (3.2s)	Ave. Time (ms)	Limit (s)	Result
DH1/ 46	0.396	32	126.72	< 0.4	Pass
DH3/ 48	1.653	16	264.48	< 0.4	Pass
DH5/ 38	2.899	11	318.89	< 0.4	Pass
2-DH1/ 46	0.410	32	131.30	< 0.4	Pass

2-DH3/ 48	1.662	16	265.92	< 0.4	Pass
2-DH5/ 38	2.911	11	320.21	< 0.4	Pass
3-DH1/ 46	0.412	32	131.94	< 0.4	Pass
3-DH3/ 48	1.661	16	265.76	< 0.4	Pass
3-DH5/ 38	2.916	11	320.76	< 0.4	Pass

Note: Since the dwell time in each channel must less than 0.4 seconds. The total time for dwell all 79 channels is 31.6 seconds. To determine the average dwell time, the frequency 2441MHz was sample in 3.2 second, 1/10th of the total 79 channel dwell time.

Minimum Channel Separation

Package/ Power	Hopping Separation (kHz)	Two-Third of 20dB Bandwidth Limit (kHz)	Result
DH1/ 46	1012	> 0.516 kHz	Pass
DH3/ 48	1000	> 0.563 kHz	Pass
DH5/ 38	1000	> 0.570 kHz	Pass
2-DH1/ 46	1000	> 0.790 kHz	Pass
2-DH3/ 48	1000	> 0.811 kHz	Pass
2-DH5/ 38	1000	> 0.805 kHz	Pass
3-DH1/ 46	1000	> 0.794 kHz	Pass
3-DH3/ 48	1000	> 0.828 kHz	Pass
3-DH5/ 38	1000	> 0.828 kHz	Pass

Note: The EUT was hopping randomly all 79 operating channels. The channel separation was measured at the middle channel, 2441 MHz. Two-Third of the highest 20dB bandwidth was used.

Minimum Number of Channels

Range (2402MHz -2480MHz)	Min. Channel Limit	Result
79	15	Pass

Note: Both BDR and EDR used the same number of hopping channels.

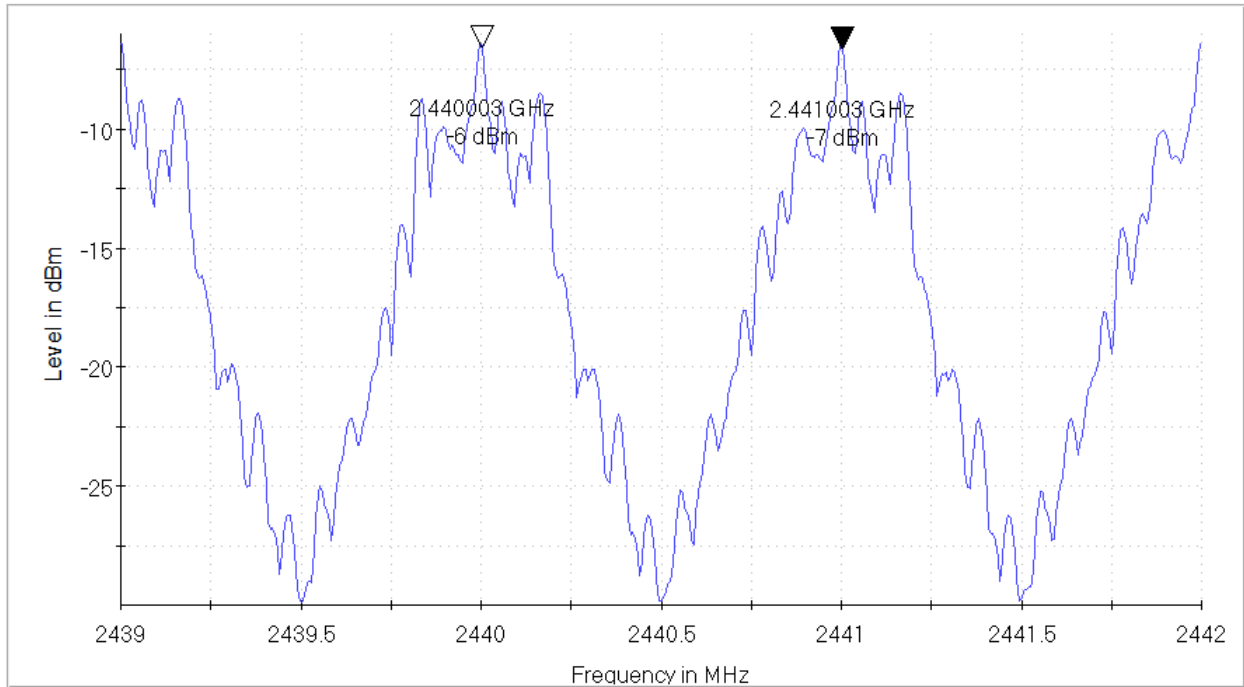

Figure 7: Hopping Separation for DH5

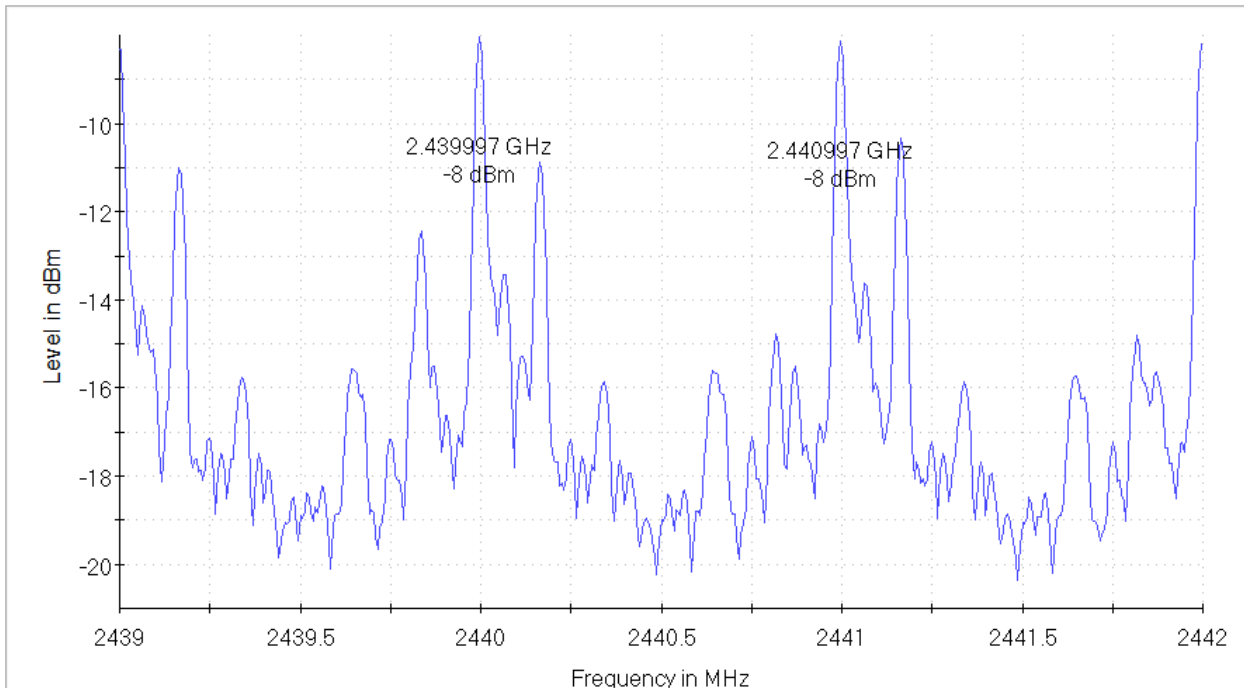

Figure 8: Hopping Separation for 2-DH5

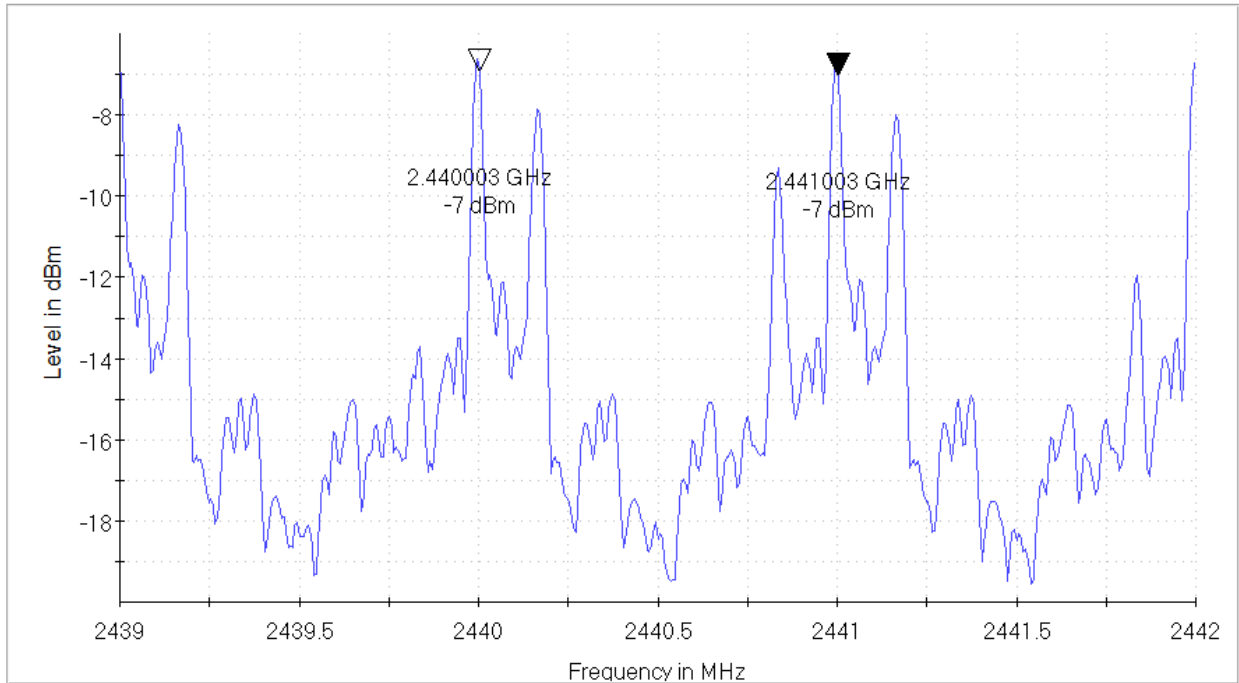
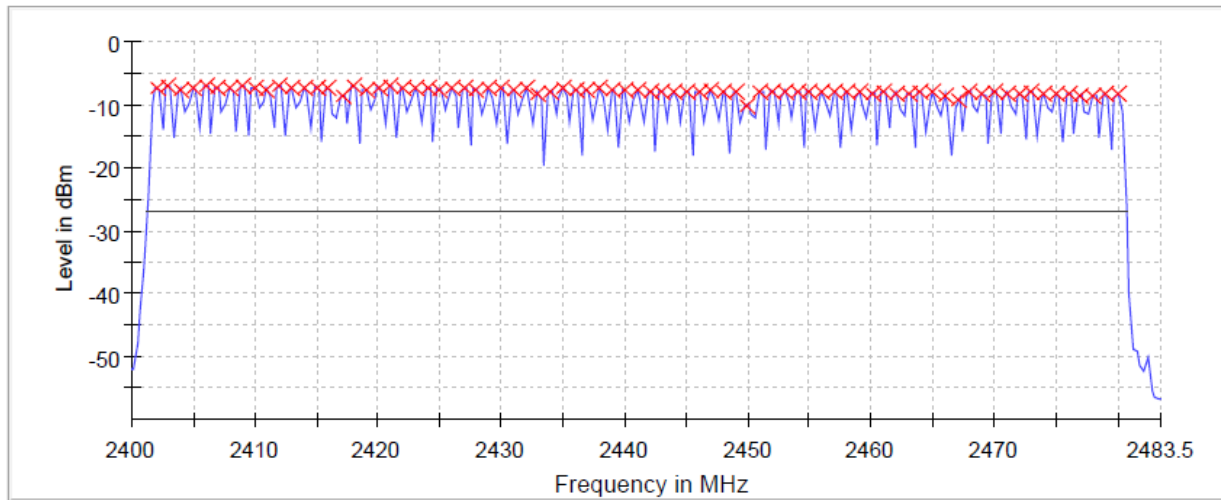

Figure 9: Hopping Separation for 3-DH5



— Hopping Sequence × Hopping Frequencies — Band Allocation

Figure 10: Number of Operating Channels (79)

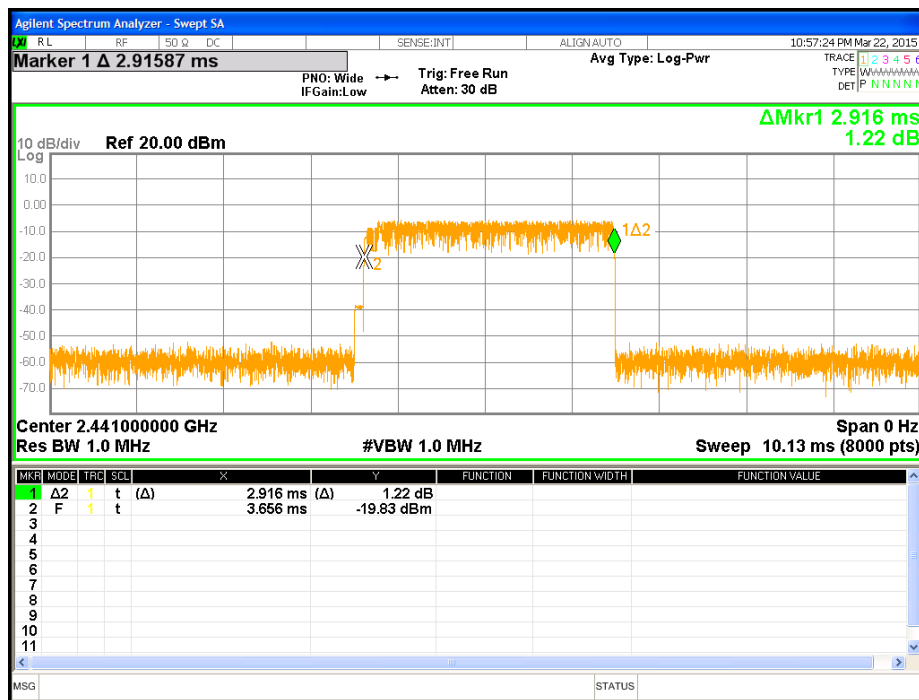

Figure 11: Pulse Width at 2441MHz for 3-DH5

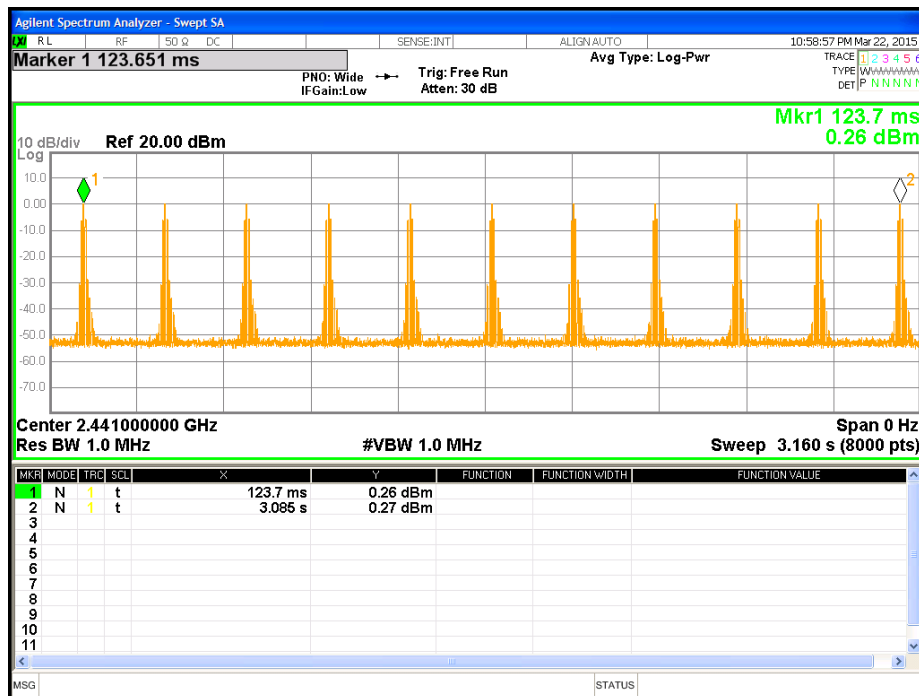

Figure 12: Average Dwell Time for Channel 2441MHz – 11 Pulses

Note: There are 11 pulses in 3.16 seconds.

4.4 Out of Band Emission requirements

The setup was identical to RF output power measurement. Intentional radiators operating under the alternative provisions to the general emission limits, must be designed to ensure that the 20 dB bandwidth of the emission, or whatever bandwidth may otherwise be specified in the specific rule section under which the equipment operates, is contained within the frequency band designated in the rule section under which the equipment is operated. The requirement to contain the designated bandwidth of the emission within the specified frequency band includes the effects from frequency sweeping, frequency hopping and other modulation techniques that may be employed as well as the frequency stability of the transmitter over expected variations in temperature and supply voltage. If the frequency stability is not specified in the regulations, it is recommended that the fundamental emission be kept within at least the central 80% of the permitted band in order to minimize the possibility of out-of-band operation.

Any frequency outside the band of 2400 MHz to 2483.5 MHz, the power output level must be below 20 dB from the in-band transmitting signal; CFR 47 Part 15.215, 15.247(d) and RSS 210 A8.5

The setup was identical to RF output power measurement.

This test was conducted on 3 channels on Elite 800X RX, SN: PP #1.

4.1.1 Results

As originally tested, the EUT was found to be compliant to the requirements of the test standard(s).

Table 5: Band Edge Requirements – Test Results

Test Conditions: Conducted Measurement, Normal Temperature and Voltage only		Date: August 7, 2014		
Antenna Type: Integrated Antenna		Power Setting: 46/ 48		
Max. Antenna Gain: +2.8 dBi		Signal State: Modulated		
Duty Cycle: 100 %		Data Rate: see below		
Ambient Temp.: 23° C		Relative Humidity: 35 %RH		
-20 dBr Band Edge Results				
Package/ Power	Operating Freq.	Limit (dBm)	Measured Value (dBm)	Result
DH5/ 48	2402 MHz	-16.67	-44.53	Pass
	2442 MHz	-17.14	-60.79	Pass
	2480 MHz	-17.95	-58.13	Pass
2-DH5/ 48	2402 MHz	-18.31	-46.62	Pass
	2442 MHz	-18.83	-60.44	Pass

	2480 MHz	-19.91	-55.36	Pass
3-DH3/ 48	2402 MHz	-18.14	-48.10	Pass
	2442 MHz	-18.81	-58.04	Pass
	2480 MHz	-19.94	-55.81	Pass

Note: The stated limits for 20 dBm are relative to each individual output per KDB 662911 Method. The worst case of each data rate is recorded.

Out of Band Emission

Package/ Power	Operating Freq.	Limit (dBm)	Measured Value (dBm)	Result
DH5/ 48	2402 MHz	-16.67	-47.01 dBm (4804.01MHz)	Pass
	2442 MHz	-17.14	-49.73 dBm (24.106GHz)	Pass
	2480 MHz	-17.95	-47.74 dBm (4960.00MHz)	Pass
2-DH5/ 48	2402 MHz	-18.31	-50.10 dBm (25.693GHz)	Pass
	2442 MHz	-18.83	-49.45 dBm (25.544GHz)	Pass
	2480 MHz	-19.91	-49.39 dBm (3305.70MHz)	Pass
3-DH3/ 48	2402 MHz	-18.14	-49.80 dBm (25.974GHz)	Pass
	2442 MHz	-18.81	-48.28 dBm (4883.40 MHz)	Pass
	2480 MHz	-19.94	-48.68 dBm (3305.70MHz)	Pass

Note: The stated limits are relative to each individual output per KDB 662911 Method.

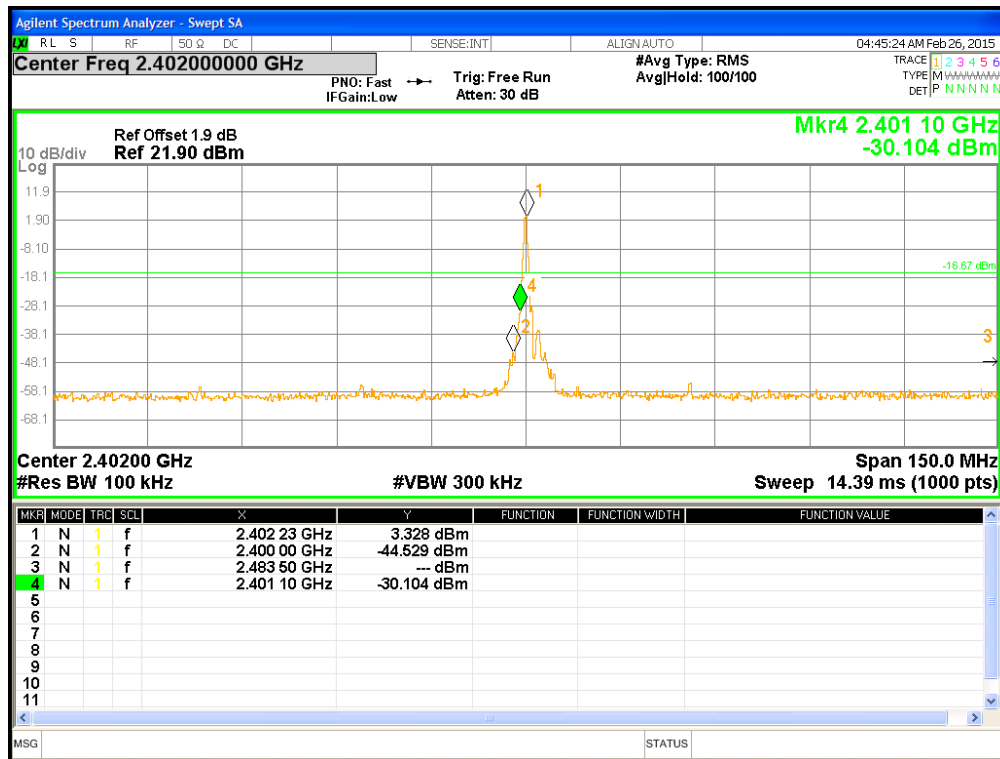

Figure 13: Band Edge Requirements at 2402 MHz – DH5

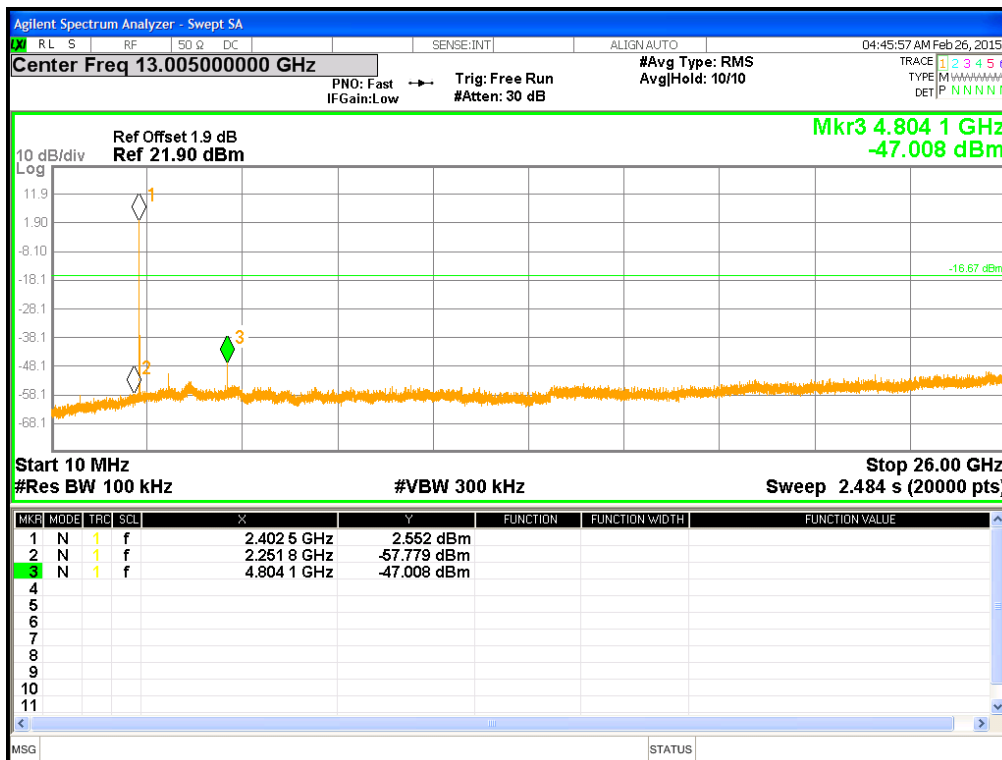

Figure 14: Out of Band Emission Requirements at 2402 MHz – DH5

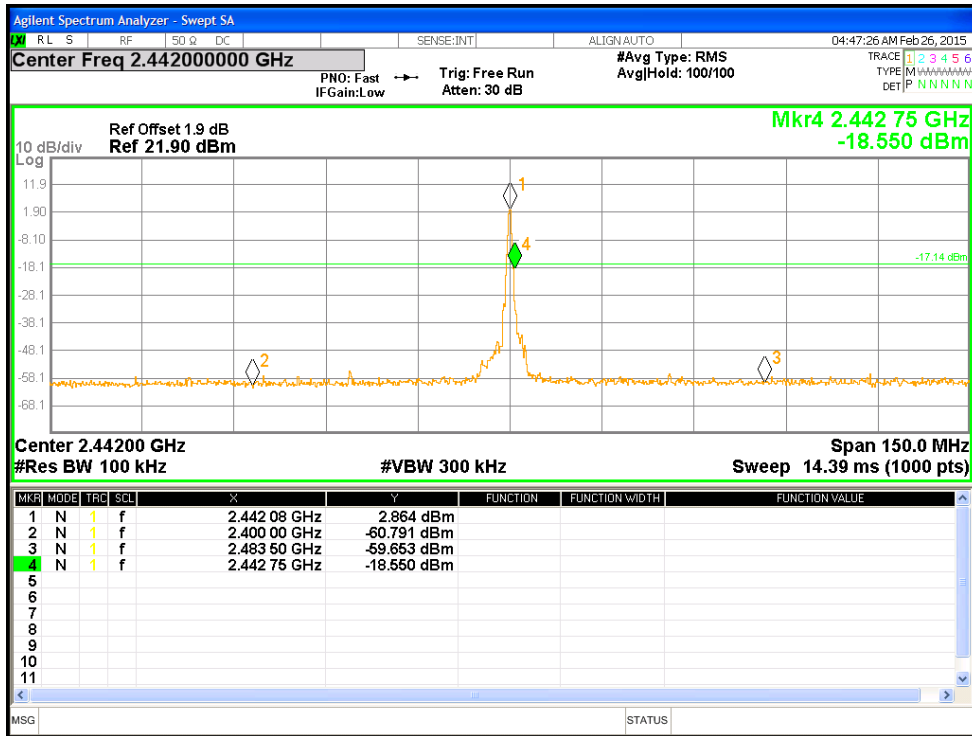

Figure 15: Band Edge Requirements at 2442 MHz – DH5

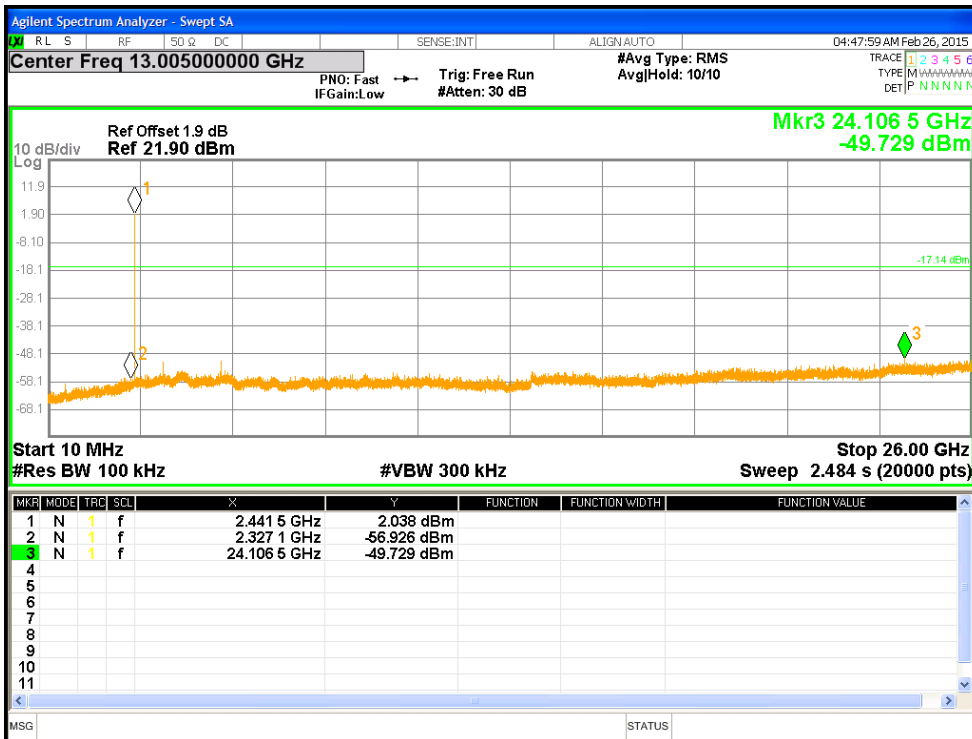

Figure 16: Out of Band Emission Requirements at 2442 MHz – DH5

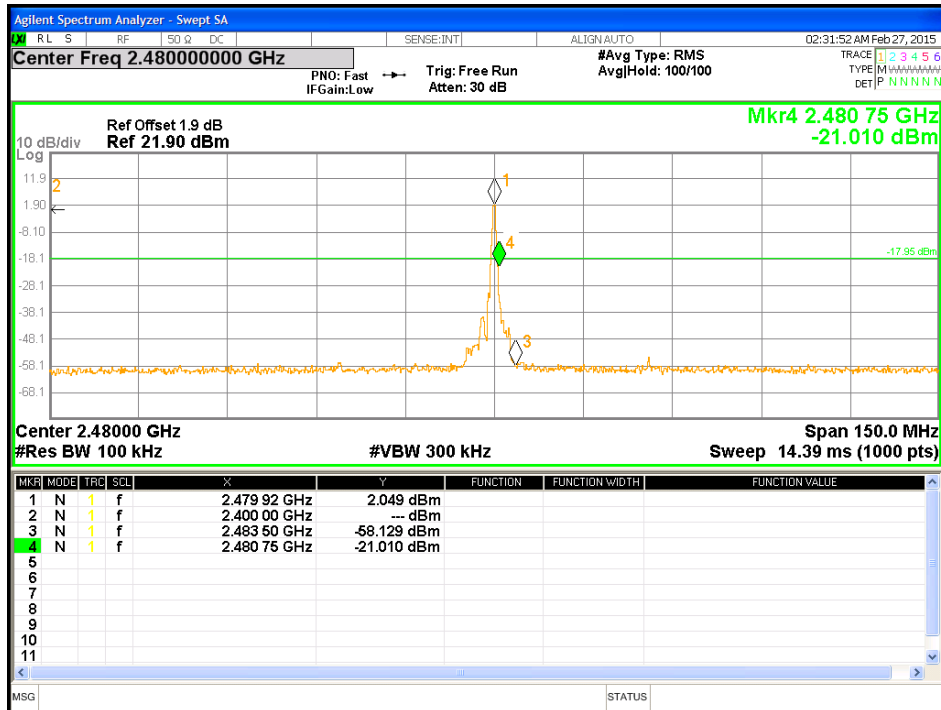

Figure 17: Band Edge Requirements at 2480 MHz – DH5

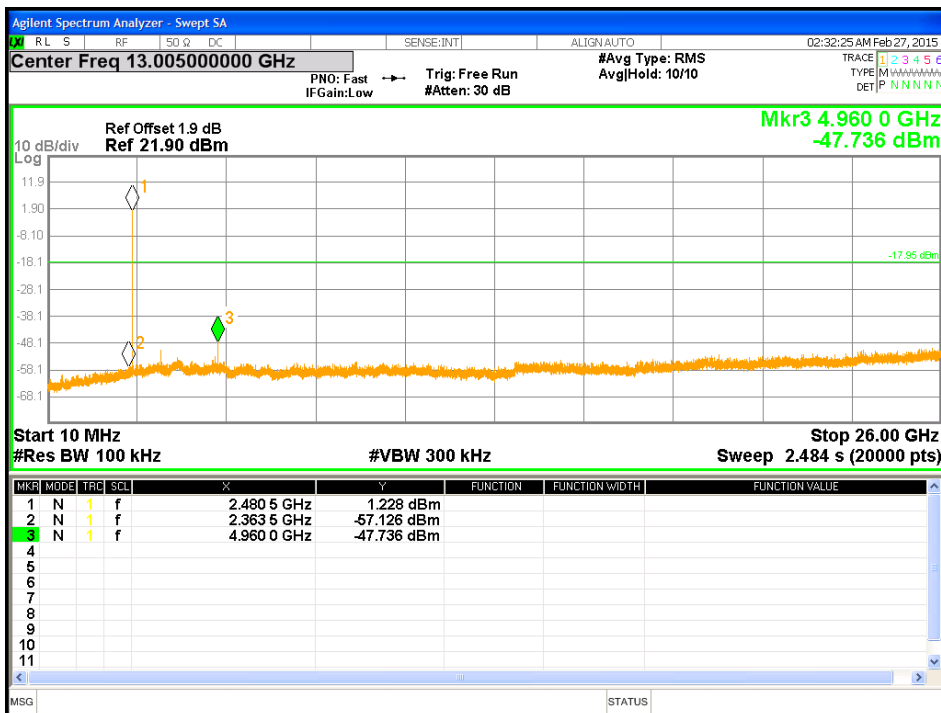

Figure 18: Out of Band Emission Requirements at 2480 MHz – DH5

4.5 Transmitter Spurious Emissions

Transmitter spurious emissions are emissions outside the frequency range of the equipment when the equipment is in transmitting mode; per requirement of CFR47 15.205, 15.209, 15.247(d), RSS 210 Sect. A.8.5

4.6.1 Test Methodology

4.6.1.1 Preliminary Test

A test program that controls instrumentation and data logging was used to automate the preliminary RF emission test procedure. The frequency range of interest was divided into sub-ranges to yield a frequency resolution of approximately 120 kHz and provide a reading at each frequency for no more than 12° of turntable rotation. For each frequency sub-range the turntable was rotated 360° while peak emission data was recorded and plotted over the frequency range of interest in horizontal and vertical antenna polarization's.

Preliminary emission profile testing was performed inside the anechoic chamber. The EUT was placed on a 1.0m x 1.5m non-conductive table 80cm above the floor. The EUT was positioned as shown in the setup photographs. The receiving antenna was placed at a distance of 3m at a fixed height of 1m. Measurement equipment was located outside of the chamber. A video camera was placed inside the chamber to view the EUT.

4.6.1.2 Final Test

For each frequency measured, the peak emission was maximized by manipulating the receiving antenna from 1 to 4 meters above the ground plane and placing it at the position that produced the maximum signal strength reading. The turntable was then rotated through 360° while observing the peak signal and placing the EUT at the position that produced maximum radiation. The six highest emissions relative to the limit were measured unless such emissions were more than 20 dB below the limit. If less than six emissions are within 20 dB of the limit, than the noise level of the receiver is measured at frequencies where emissions are expected. Multiples of all oscillator and microprocessor frequencies were also checked.

Final testing was performed on an NSA compliant test site. The EUT was placed on a 1.0m x 1.5m non-conductive table 80cm above the ground plane. The placement of EUT and cables were the same as for preliminary testing and is shown in the setup photographs.

The final scans performed on the worst axis, Y-Axis, for three operating channels: 2402 MHz, 2441 MHz, and 2480 MHz at DH5 / 48.

4.6.1.3 Deviations

None.

4.6.2 Transmitter Spurious Emission Limit

The spurious emissions of the transmitter shall not exceed the values in CFR47 Part 15.205, 15.209: 2013 and RSS 210 A1.1.2 2010.

Frequency (MHz)	Field strength (microvolts/meter)	Measurement distance (meters)
0.009-0.490	2400/F (kHz)	300
0.490-1.705	24000/F (kHz)	30
1.705-30.0	30	30
30-88	100 **	3
88-216	150 **	3
216-960	200 **	3
Above 960	500	3

All harmonics and spurious emission which are outside of the restricted band shall be 20 dB below the in-band emission.

4.6.3 Test Results

The final measurement data was taken under the worst case operating modes, configurations, and/or cable positions. It also reflects the results including any modifications and/or special accessories listed in Sections 1.4 and Test Plan.

As originally tested, the EUT was found to be compliant to the requirements of the test standard(s).

Table 6: Transmit Spurious Emission at Restricted Band Edge Requirements

Test Conditions: Radiated Measurement at 3 meters					Date: March 2, 2015			
Antenna Type: Integrated Antenna					Power Setting: Fixed.			
Max. Antenna Gain: +2.8 dBi					Signal State: Modulated			
Duty Cycle: 100 %					Data Rate: see below			
Ambient Temp.: 23° C					Relative Humidity: 30 %RH			
Band Edge Results								
Freq. MHz	Level dBuV/m	Pol. V/H	15.209/15.247 Limit	Margin	Detector Pk/QP/Avg	Azimuth degrees	Height meters	Comments
2390	45.46	V	74.00	-28.54	Pk	87	167	TX at 2402 MHz, DH5
2390	35.28	V	54.00	-18.72	Ave	87	167	TX at 2402 MHz, DH5
2390	45.13	H	74.00	-28.87	Pk	253	150	TX at 2402 MHz, DH5
2390	36.79	H	54.00	-17.21	Ave	253	150	TX at 2402 MHz, DH5
2483.5	50.14	V	74.00	-23.86	Pk	92	154	TX at 2480 MHz, DH5
2483.5	39.96	V	54.00	-14.04	Ave	92	154	TX at 2480 MHz, DH5
2483.5	50.55	H	74.00	-23.45	Pk	136	217	TX at 2480 MHz, DH5
2483.5	40.43	H	54.00	-13.57	Ave	136	217	TX at 2480 MHz, DH5

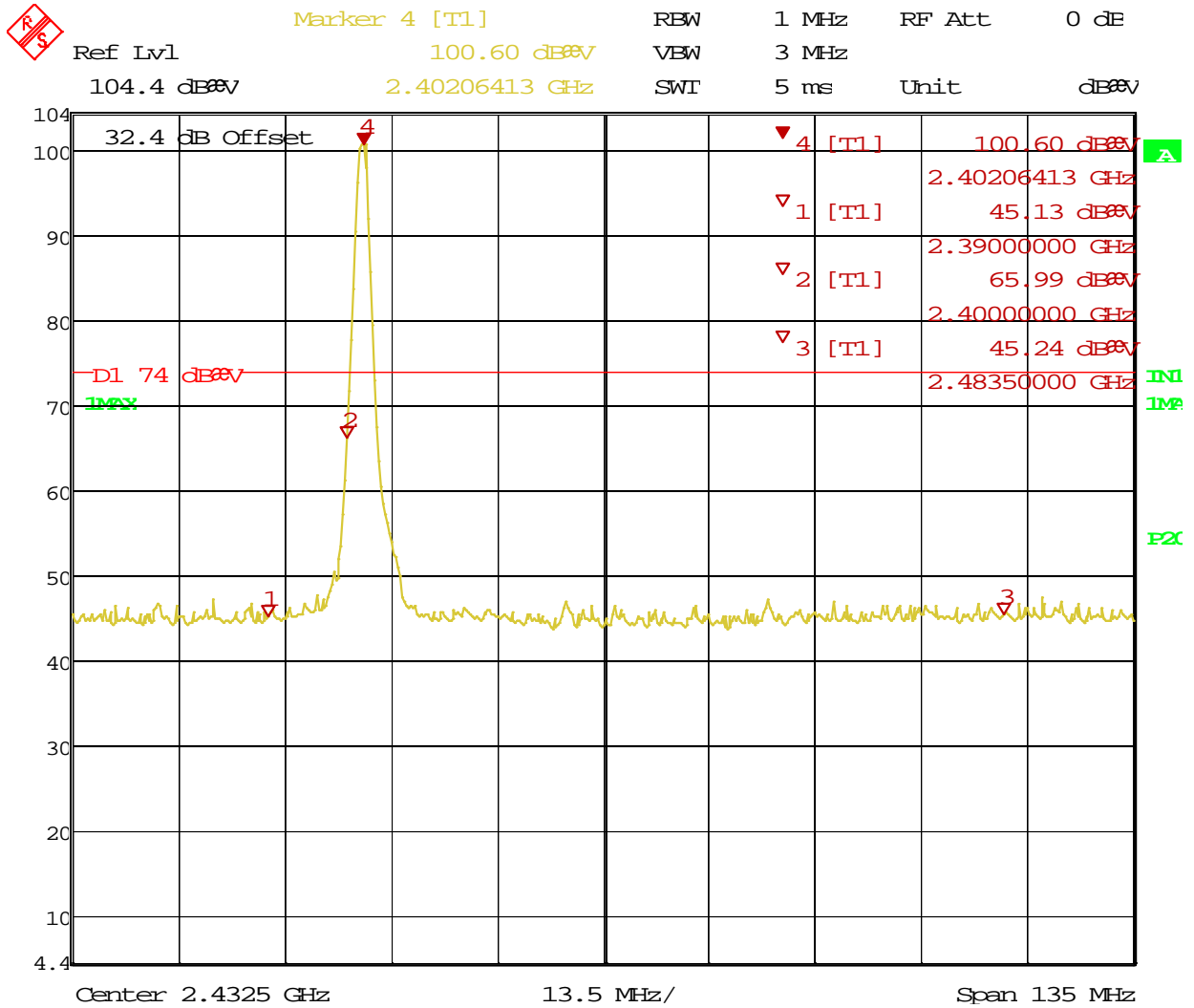

Date: 2.MAR.2015 15:34:08

Figure 19: Radiated Emission at the Edge for Channel 2402 MHz at DH5 – Horizontal (Peak)

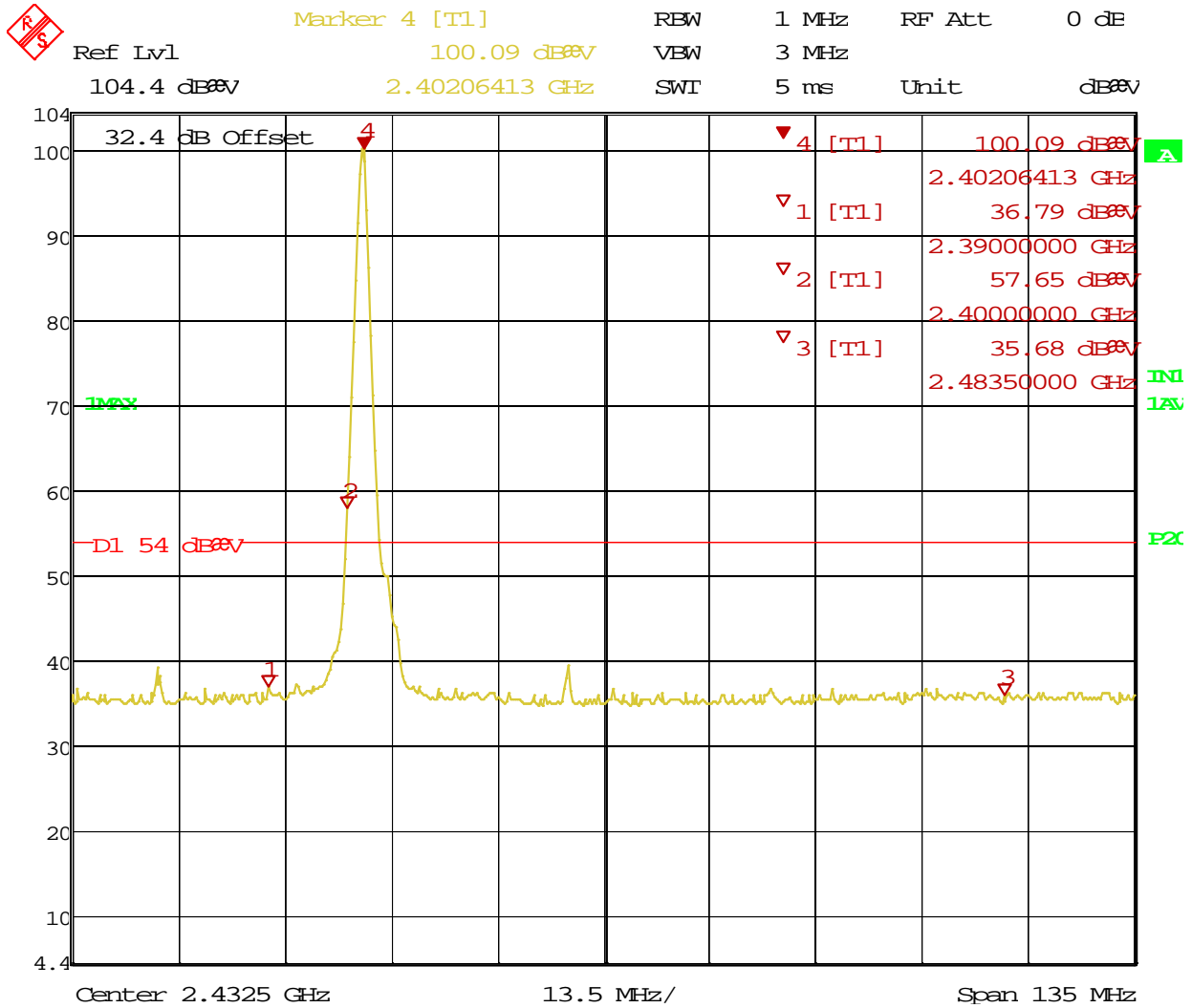

Date: 2.MAR.2015 15:34:33

Figure 20: Radiated Emission at the Edge for Channel 2402 MHz at DH5 – Horizontal (Avg)

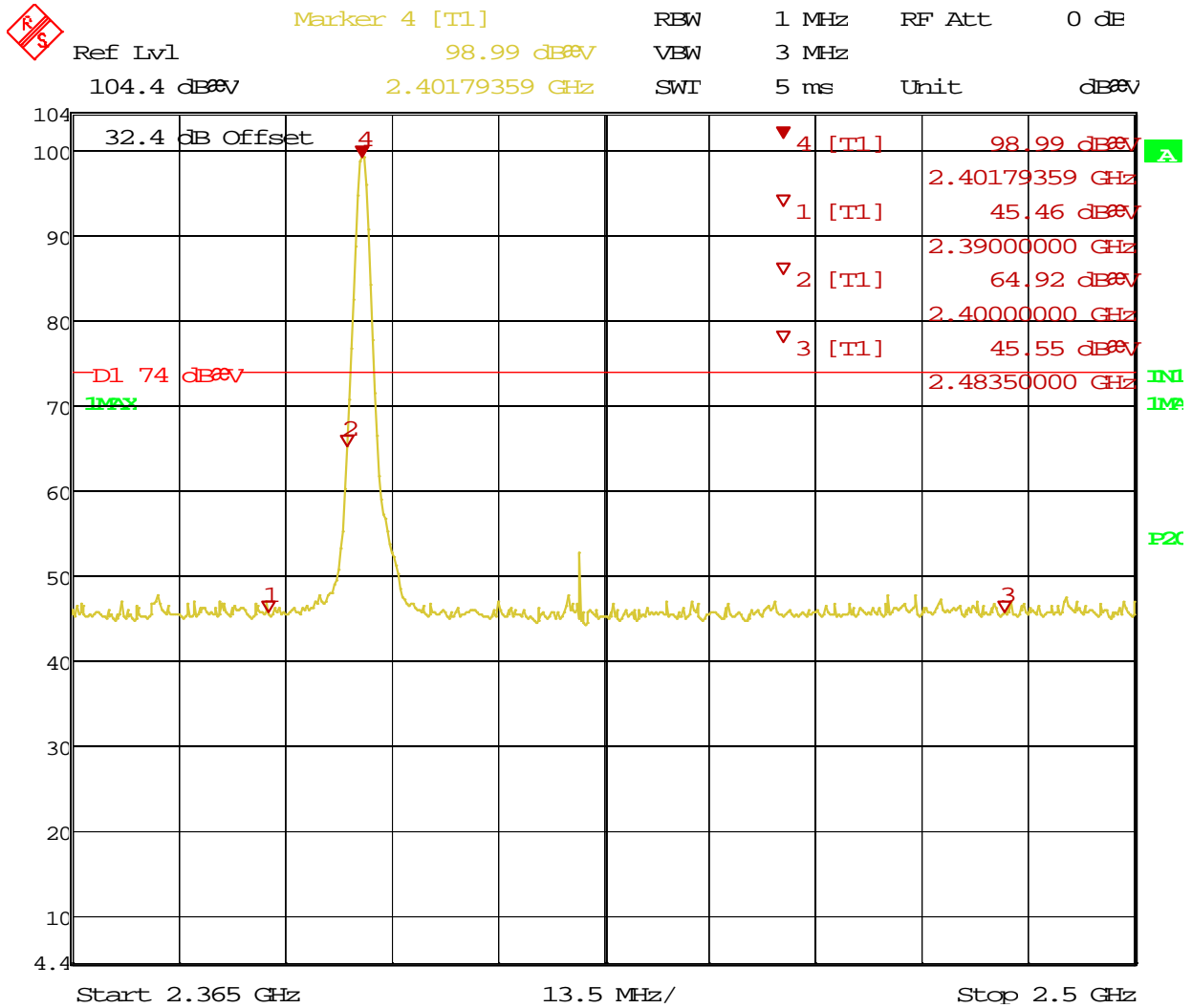

Date: 2.MAR.2015 15:29:29

Figure 21: Radiated Emission at the Edge for Channel 2402 MHz at DH5 – Vertical (Pk)

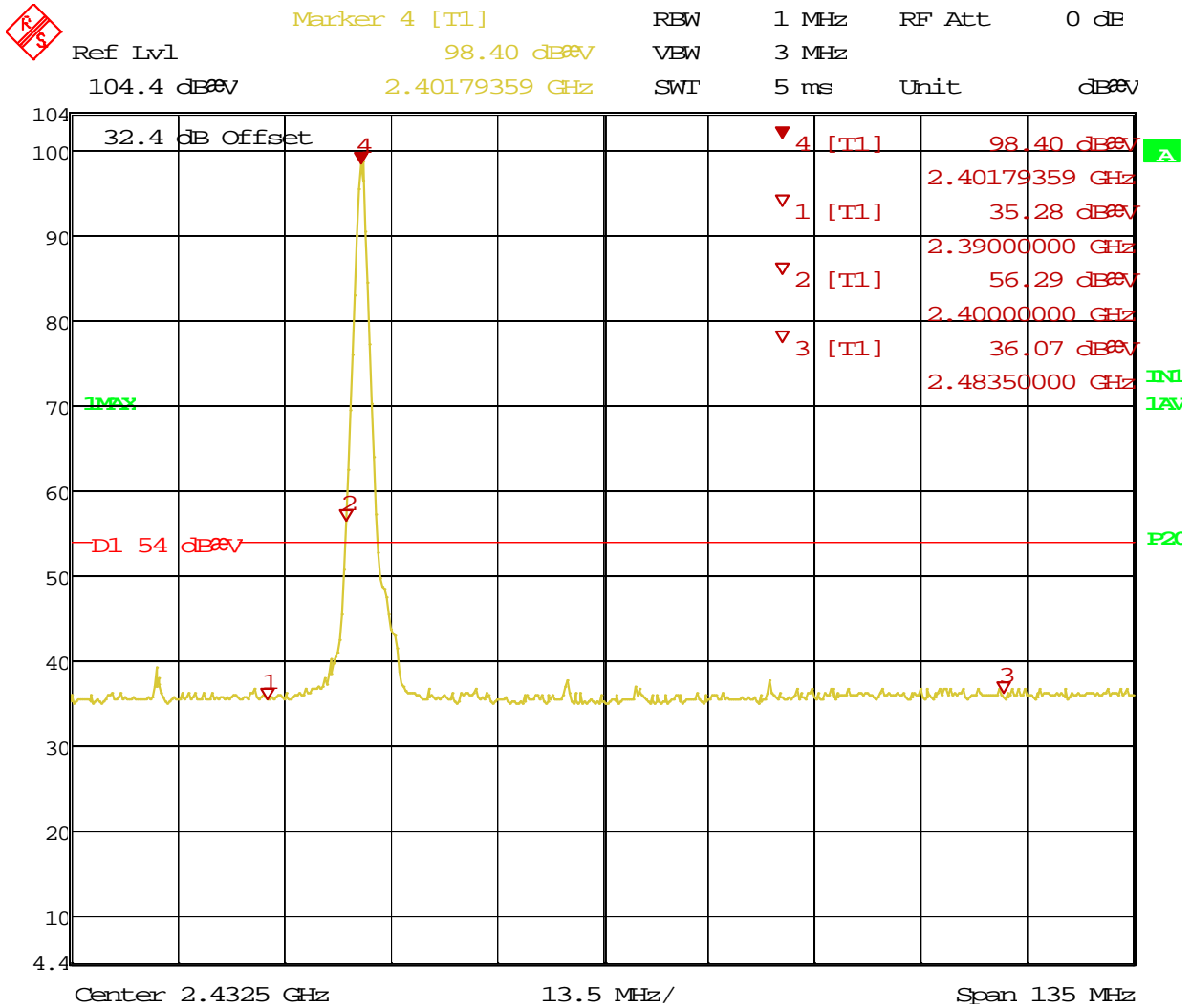

Date: 2.MAR.2015 15:30:36

Figure 22: Radiated Emission at the Edge for Channel 2402 MHz at DH5 – Vertical (avg)

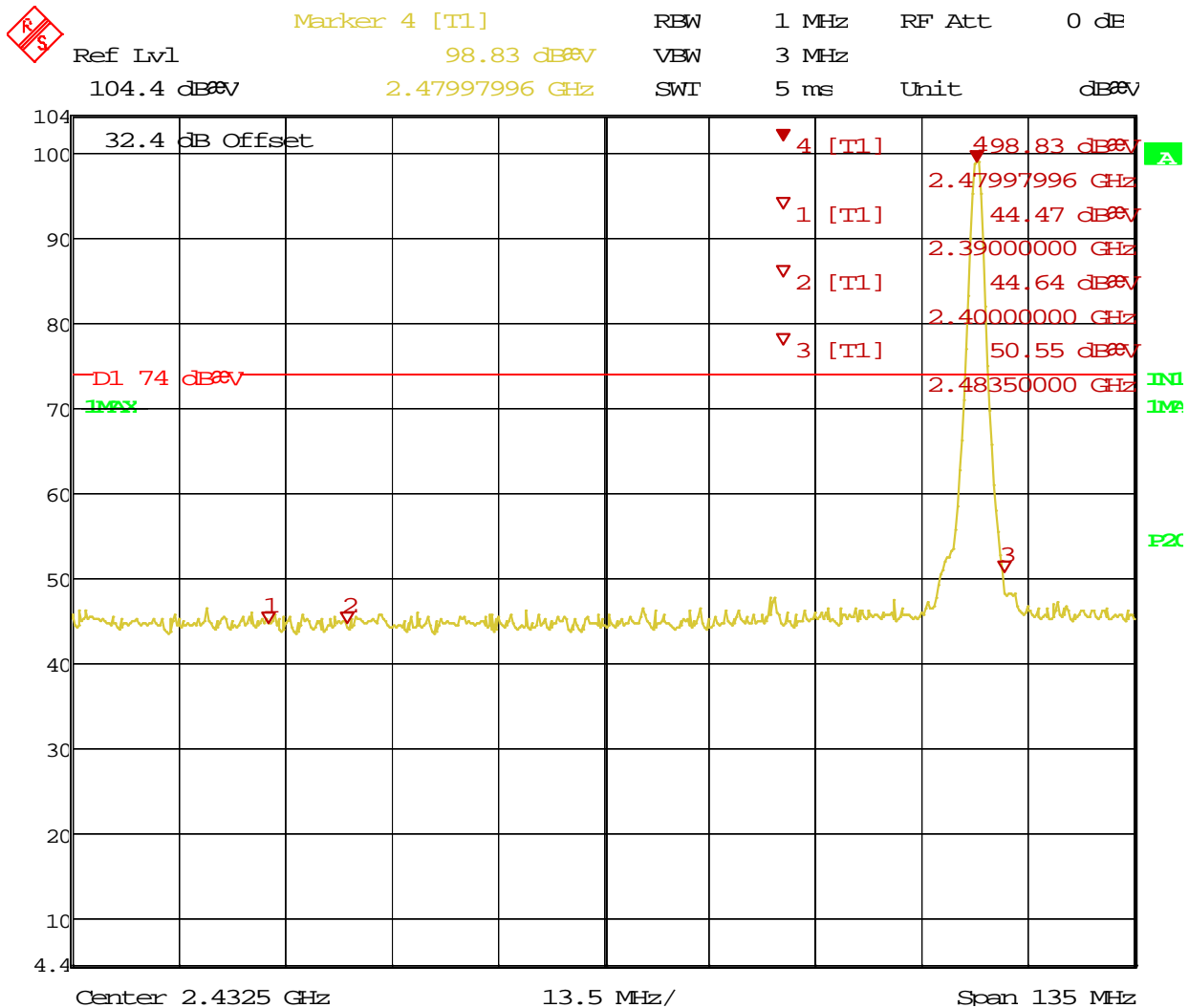

Date: 2.MAR.2015 15:42:07

Figure 23: Radiated Emission at the Edge for Channel 2480 MHz at DH5 – Horizontal (Pk)

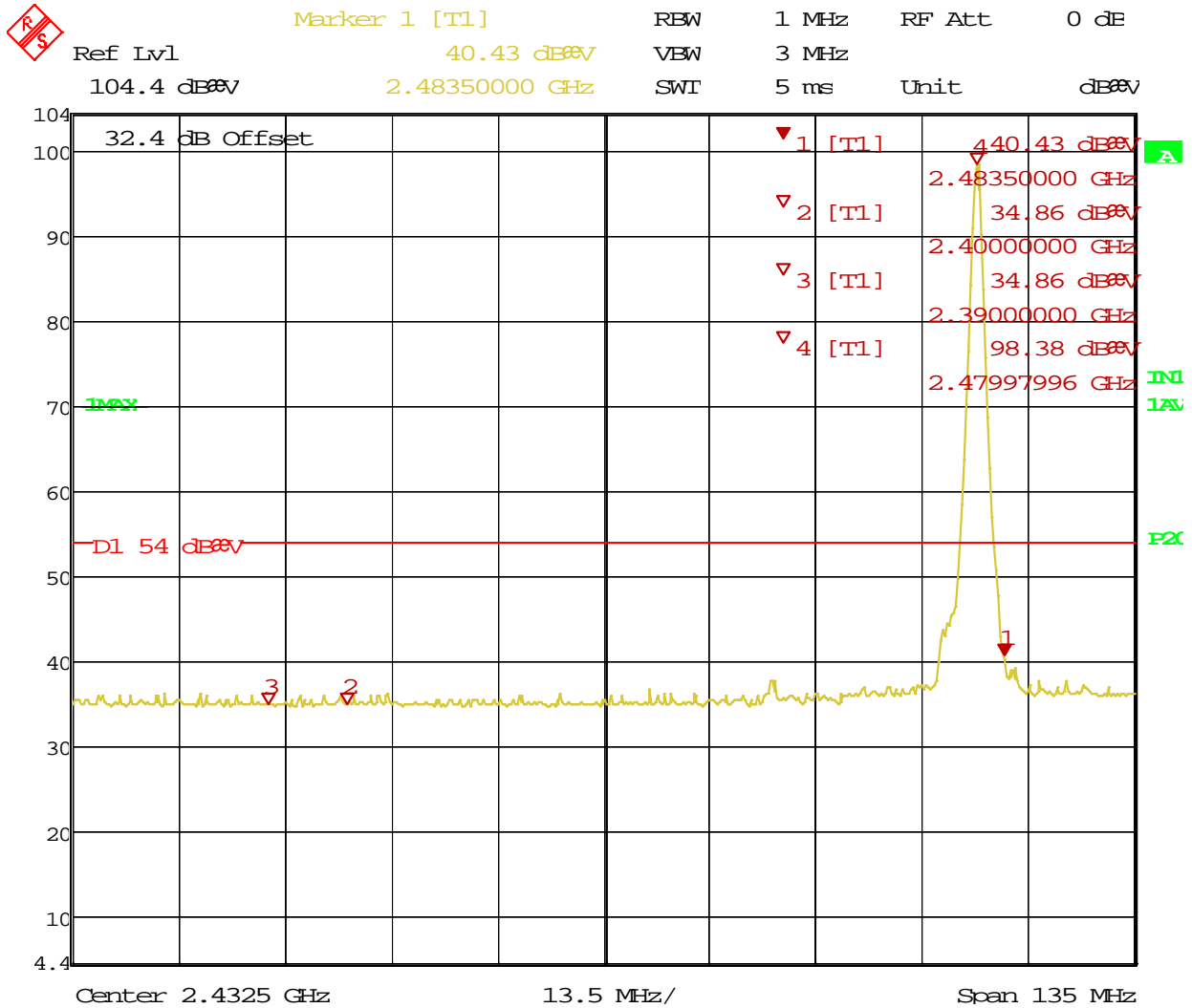

Date: 2.MAR.2015 15:44:07

Figure 24: Radiated Emission at the Edge for Channel 2480 MHz at DH5 – Horizontal (Avg)

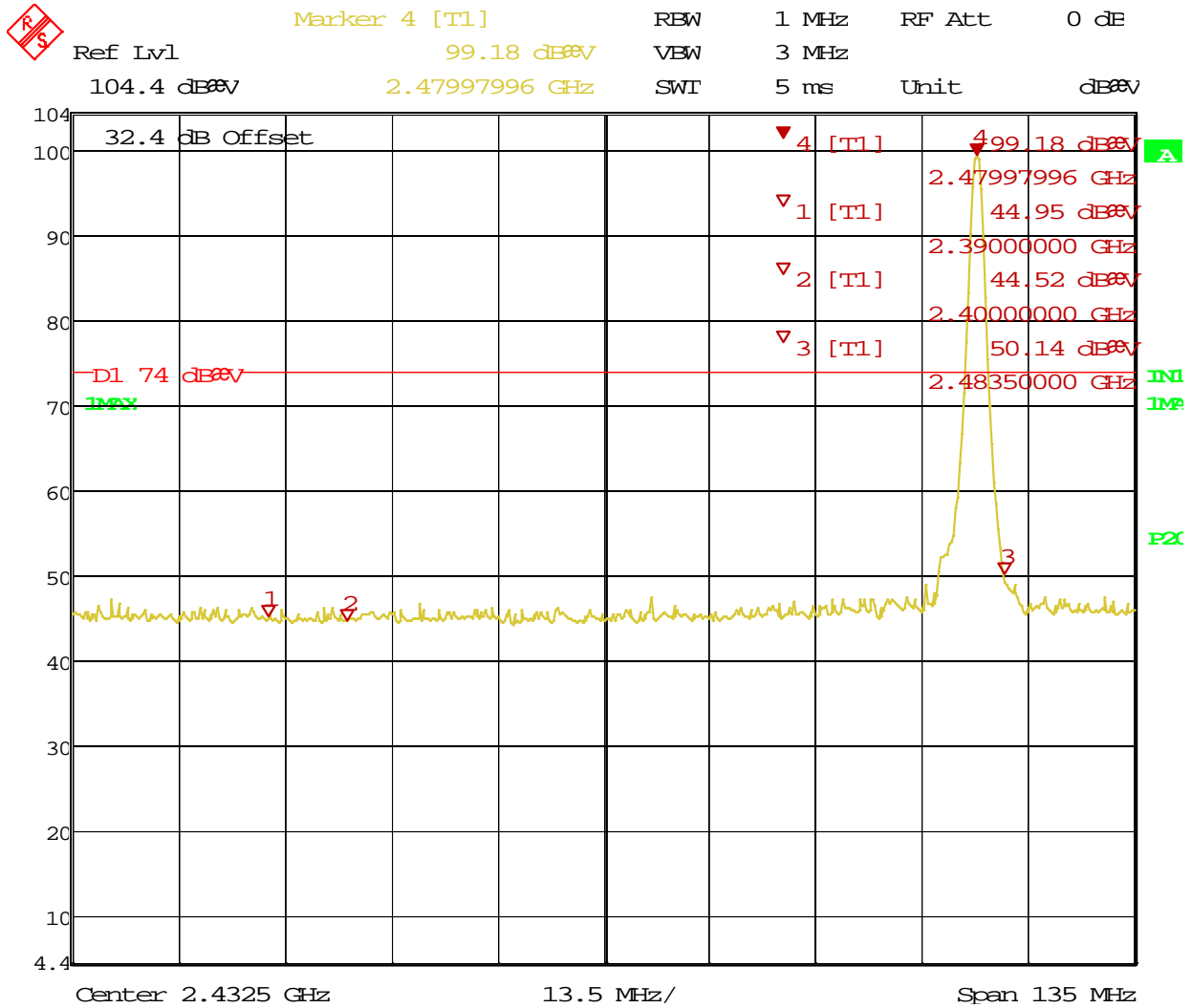

Date: 2.MAR.2015 15:39:15

Figure 25: Radiated Emission at the Edge for Channel 2480 MHz at DH5 – Vertical (Pk)

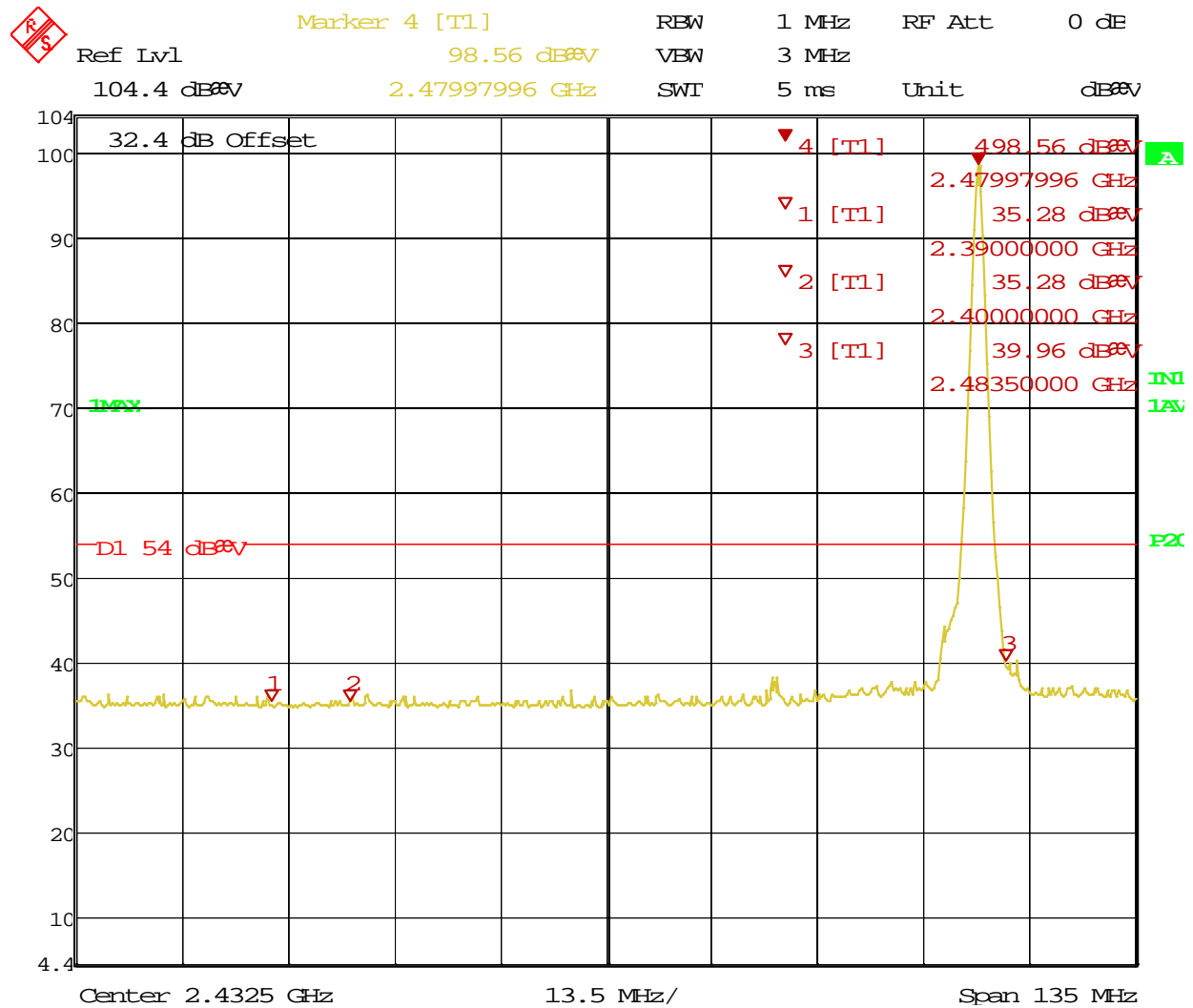

Date: 2.MAR.2015 15:39:34

Figure 26: Radiated Emission at the Edge for Channel 2480 MHz at DH5 – Vertical (Avg)

SOP 1 Radiated Emissions						Tracking # 31560604.001 Page 1 of 6					
EUT Name	Wireless Audio Headset					Date	January 23, 2015				
EUT Model	Elite 800X RX					Temp / Hum in	23°C / 35%rh				
EUT Serial	PP #2					Temp / Hum out	N/A				
EUT Comfit.	Integrated Antenna on Y-Axis					Line AC / Freq	3.7 VDC				
Standard	CFR47 Part 15 Subpart C					RBW / VBW	120KHz/300KHz				
Dist/Ant Used	3m /JB3					Performed by	Jeremy Luong				
30 -1000 MHz radiated emission at 2441 MHz											
Freq	Raw	Cable	AF	Level	Detector	Pol	Hgt	Azt	Limit	Margin	Result
MHz	dBuV/m	dB	dB	dBuV/m	Peak	-	cm	Deg	dBuV	dB	
38.13	64.83	1.31	-28.21	37.93	Pk	H	121	368	40.00	-2.07	Pass
69.41	45.63	1.43	-24.46	22.60	Pk	H	154	278	40.00	-17.40	Pass
48.04	49.09	1.35	-23.23	27.21	Pk	V	101	16	40.00	-12.79	Pass
51.52	44.33	1.37	-24.46	21.24	Pk	V	171	279	40.00	-18.76	Pass
58.65	54.13	1.39	-25.14	30.38	Pk	V	144	310	40.00	-9.62	Pass
59.55	48.22	1.39	-25.14	24.47	Pk	V	129	281	40.00	-15.53	Pass
Spec Margin = Level – Limit, Level = Raw + Cable + AF ± Uncertainty AF= Amp Gain + ANT Factor											
Combined Standard Uncertainty $u_c(y) = \pm 4.52$ dB Expanded Uncertainty $U = ku_c(y)$ $k = 2$ for 95% confidence											
Note : None.											

SOP 1 Radiated Emissions

Tracking # 31560604.001 Page 2 of 6

EUT Name	Wireless Audio Headset	Date	January 27, 2015
EUT Model	Elite 800X RX	Temp / Hum in	23°C / 35%rh
EUT Serial	PP #2	Temp / Hum out	N/A
EUT Comfit.	Integrated Antenna on Y-Axis	Line AC / Freq	3.7 VDC
Standard	CFR47 Part 15 Subpart C	RBW / VBW	120KHz/300KHz
Dist/Ant Used	3m /JB3	Performed by	Jeremy Luong

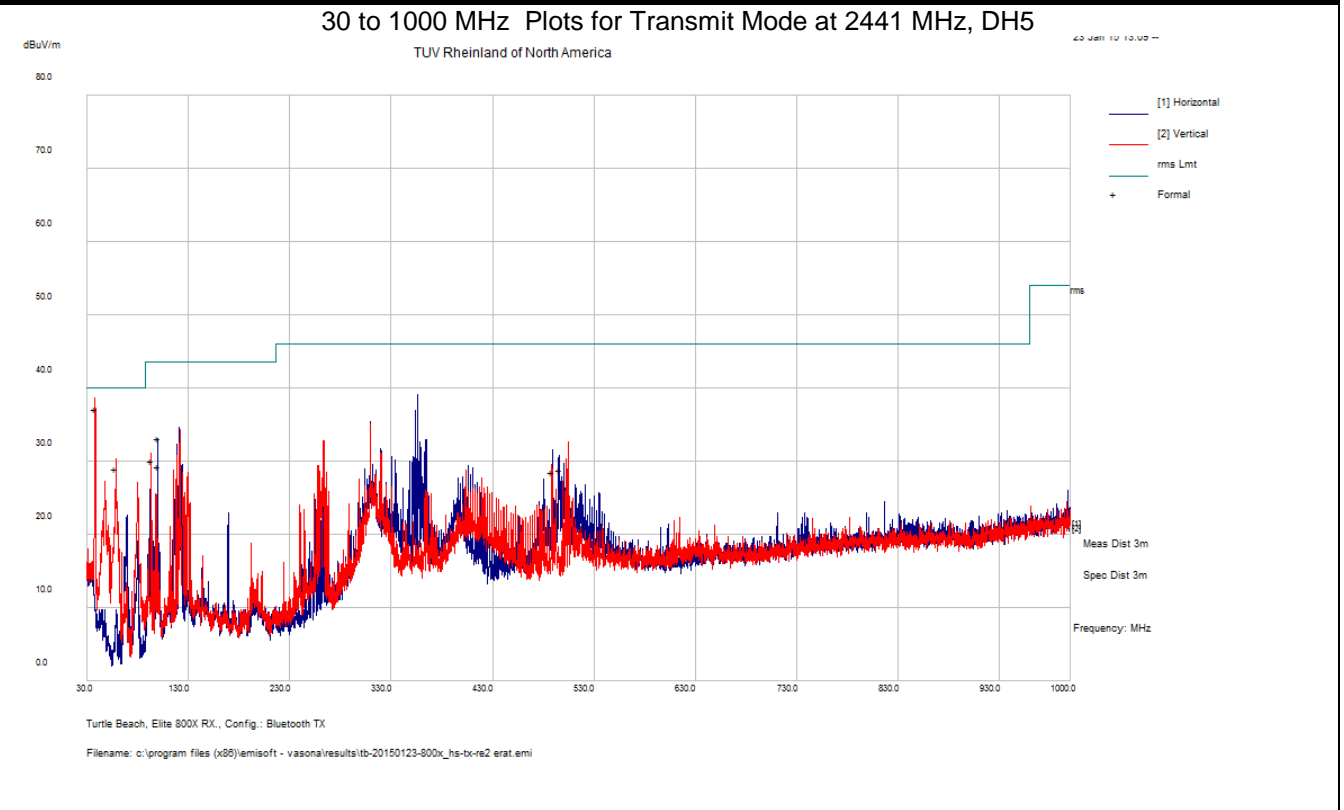

Note: Plot was scanned in the peak mode.

SOP 1 Radiated Emissions											Tracking # 31560604.001 Page 3 of 6	
EUT Name		Wireless Audio Headset					Date		January 27, 2015			
EUT Model		Elite 800X RX					Temp / Hum in		23°C / 31%rh			
EUT Serial		PP #2					Temp / Hum out		N/A			
EUT Comfit.		Integrated Antenna on Y-Axis					Line AC / Freq		3.7 VDC			
Standard		CFR47 Part 15 Subpart C					RBW / VBW		120KHz/300KHz			
Dist/Ant Used		3m – DRH-118 / 1m - RA42-K-F-4B-C					Performed by		Jeremy Luong			
Freq.	Raw	Cbl	AF	Level	Det.	Pol.	Hght.	Azt	Limit	Margin	Result	
MHz	dBuV/m	dB	dB	dBuV/m		H/V	cm	deg	dBuV/m	dB		
Above 1GHz Radiated Emission at 2402 MHz, DH5												
1602.09	69.69	0.93	-25.49	45.13	Ave	H	157	112	54.00	-8.87	Pass	
4804.16	62.39	1.65	-16.37	47.67	Ave	H	191	222	54.00	-6.33	Pass	
3203.93	59.25	1.33	-19.71	40.87	Ave	V	191	342	54.00	-13.13	Pass	
Above 1GHz Radiated Emission at 2441 MHz, DH5												
1626.71	69.76	0.94	-25.23	45.47	Ave	H	148	114	54.00	-8.53	Pass	
4882.15	63.35	1.67	-16.32	48.70	Ave	H	236	216	54.00	-5.30	Pass	
1852.10	40.96	1.01	-23.82	18.15	Ave	V	225	282	54.00	-35.85	Pass	
3253.34	55.70	1.34	-19.63	37.41	Ave	V	157	334	54.00	-16.59	Pass	
Above 1GHz Radiated Emission at 2480 MHz, DH5												
1652.64	68.66	0.95	-24.94	44.68	Ave	H	105	102	54.00	-9.32	Pass	
4959.99	62.92	1.68	-16.38	48.22	Ave	H	205	226	54.00	-5.78	Pass	
3305.36	55.00	1.35	-19.44	36.91	Ave	V	147	84	54.00	-17.09	Pass	
Spec Margin = Level – Limit, Level = Raw + Cable + AF ± Uncertainty												
AF= Amp Gain + ANT Factor												
Combined Standard Uncertainty $u_c(y) = \pm 4.52$ dB Expanded Uncertainty $U = ku_c(y)$ $k = 2$ for 95% confidence												
Note All emissions met restricted band limit.												

SOP 1 Radiated Emissions

Tracking # 31560604.001 Page 4 of 6

EUT Name	Wireless Audio Headset	Date	January 27, 2015
EUT Model	Elite 800X RX	Temp / Hum in	23°C / 31%rh
EUT Serial	PP #2	Temp / Hum out	N/A
EUT Config.	Integrated Antenna on Y-Axis	Line AC	3.7 VDC
Standard	CFR47 Part 15 Subpart C	RBW / VBW	1 MHz/ 3 MHz
Dist/Ant Used	3m – DRH-118 / 1m - RA42-K-F-4B-C	Performed by	Jeremy Luong

Above 1 GHz Radiated Emission Plot for Transmit Mode at 2402 MHz, DH5

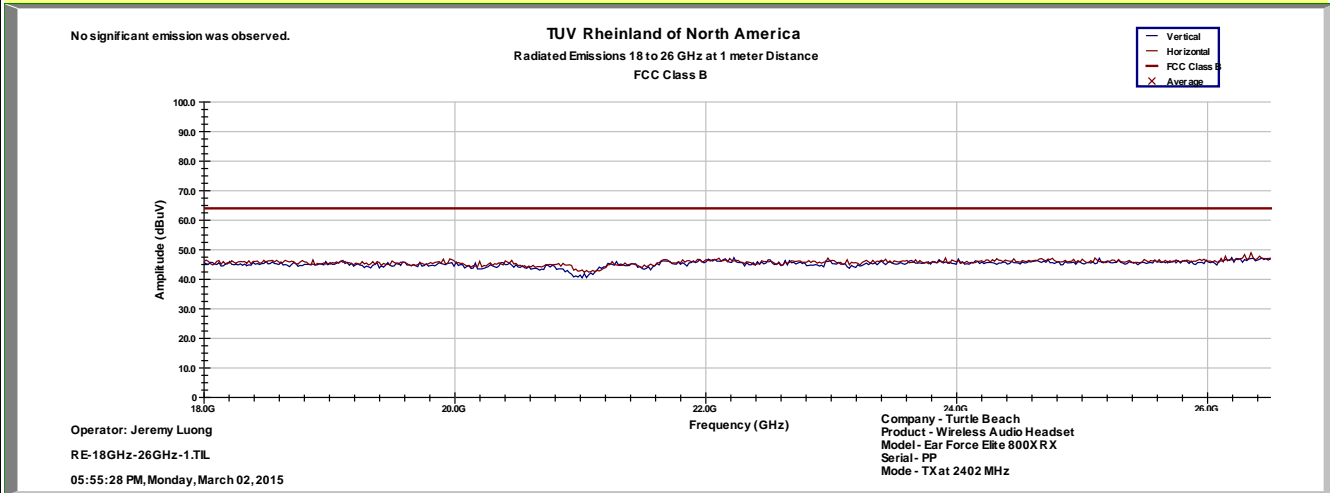
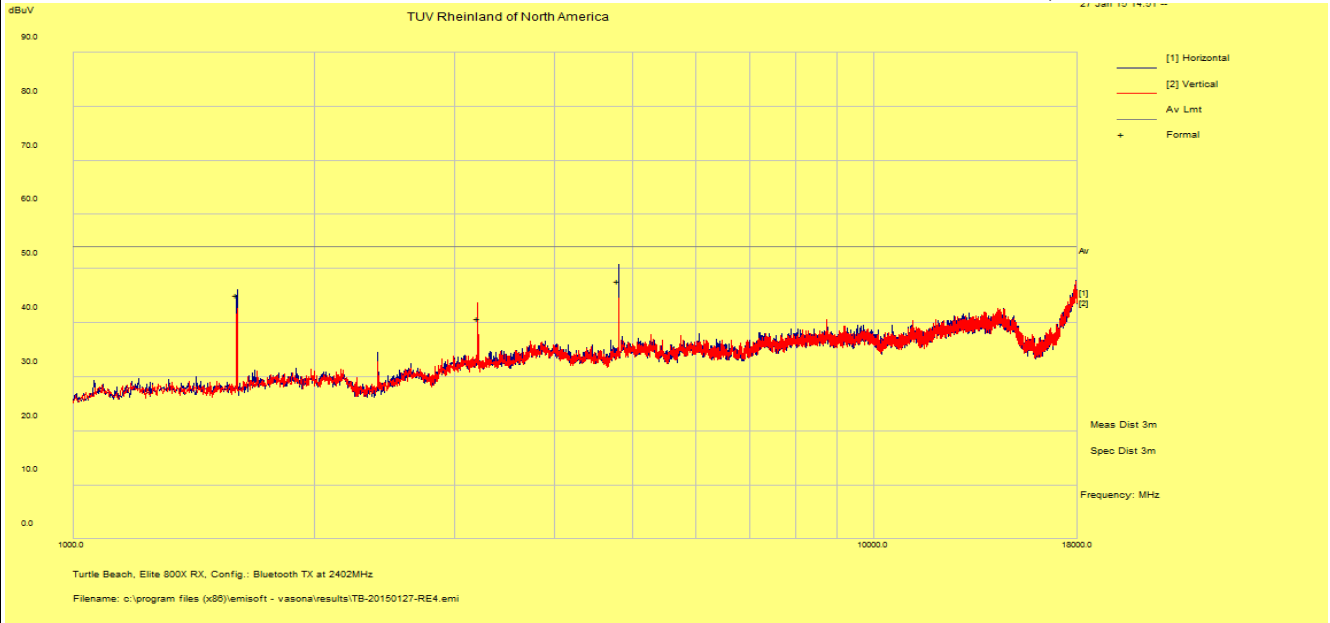

Notes: 1 GHz – 25 GHz was scanned at 1m distance.

SOP 1 Radiated Emissions

Tracking # 31560604.001 Page 5 of 6

EUT Name	Wireless Audio Headset	Date	January 27, 2015
EUT Model	Elite 800X RX	Temp / Hum in	23°C / 31%rh
EUT Serial	PP #2	Temp / Hum out	N/A
EUT Config.	Integrated Antenna on Y-Axis	Line AC	3.7 VDC
Standard	CFR47 Part 15 Subpart C	RBW / VBW	1 MHz/ 3 MHz
Dist/Ant Used	3m – DRH-118 / 1m - RA42-K-F-4B-C	Performed by	Jeremy Luong

Above 1 GHz Radiated Emission Plot for Transmit Mode at 2441 MHz, DH5

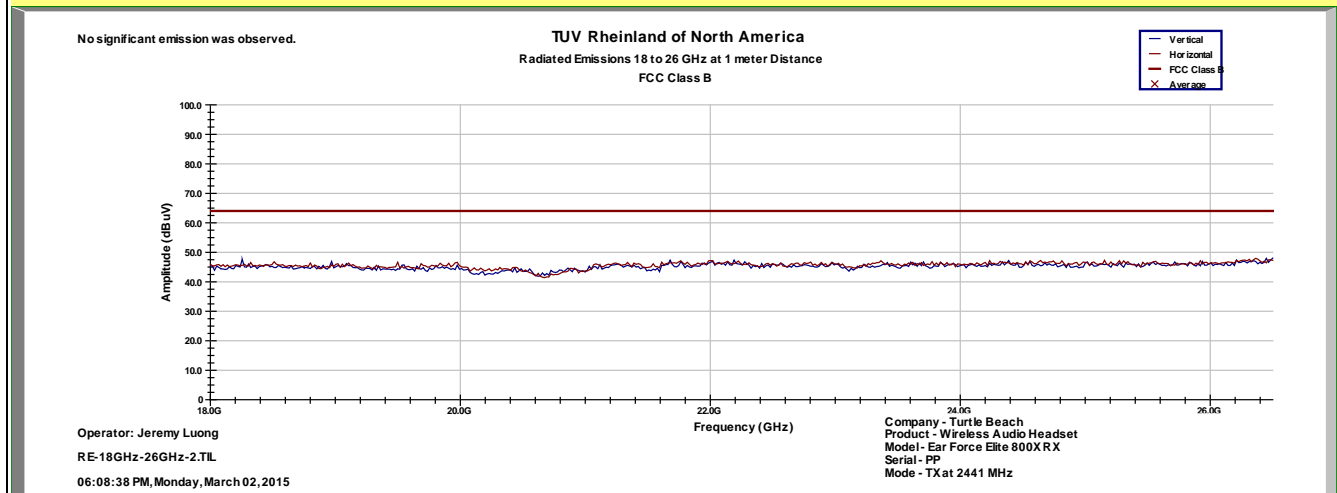
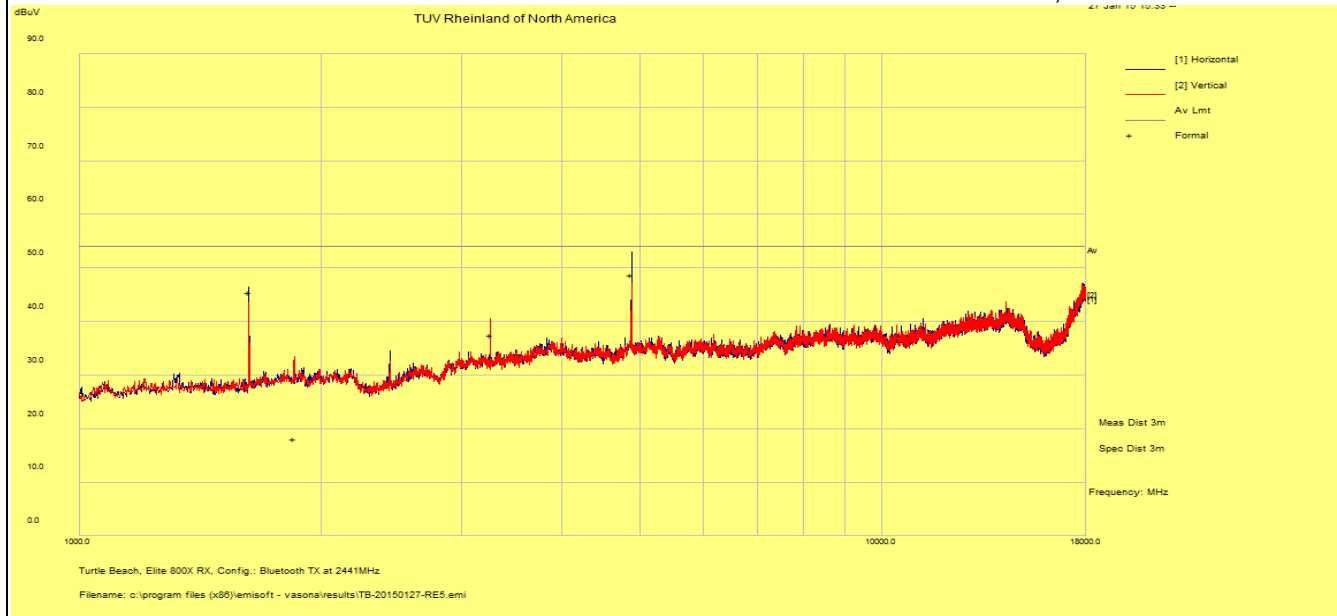

Notes: 1 GHz – 25 GHz was scanned at 1m distance.

SOP 1 Radiated Emissions

Tracking # 31560604.001 Page 6 of 6

EUT Name	Wireless Audio Headset	Date	January 27, 2015
EUT Model	Elite 800X RX	Temp / Hum in	23°C / 31%rh
EUT Serial	PP #2	Temp / Hum out	N/A
EUT Config.	Integrated Antenna on Y-Axis	Line AC	3.7 VDC
Standard	CFR47 Part 15 Subpart C	RBW / VBW	1 MHz/ 3 MHz
Dist/Ant Used	3m – DRH-118 / 1m - RA42-K-F-4B-C	Performed by	Jeremy Luong

Above 1 GHz Plots for Transmit Mode at 2480 MHz DH5

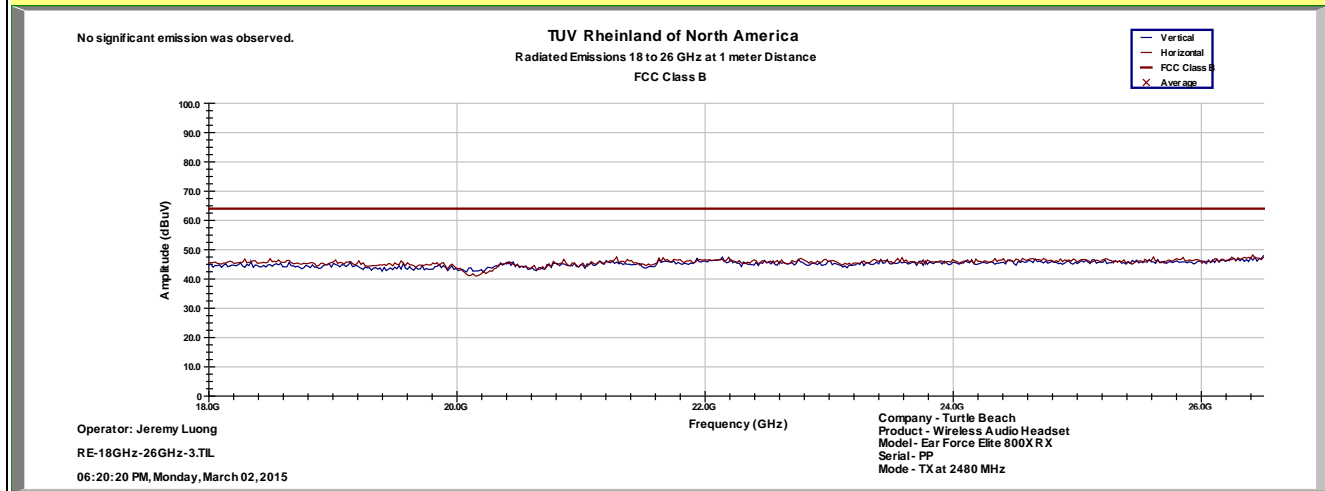
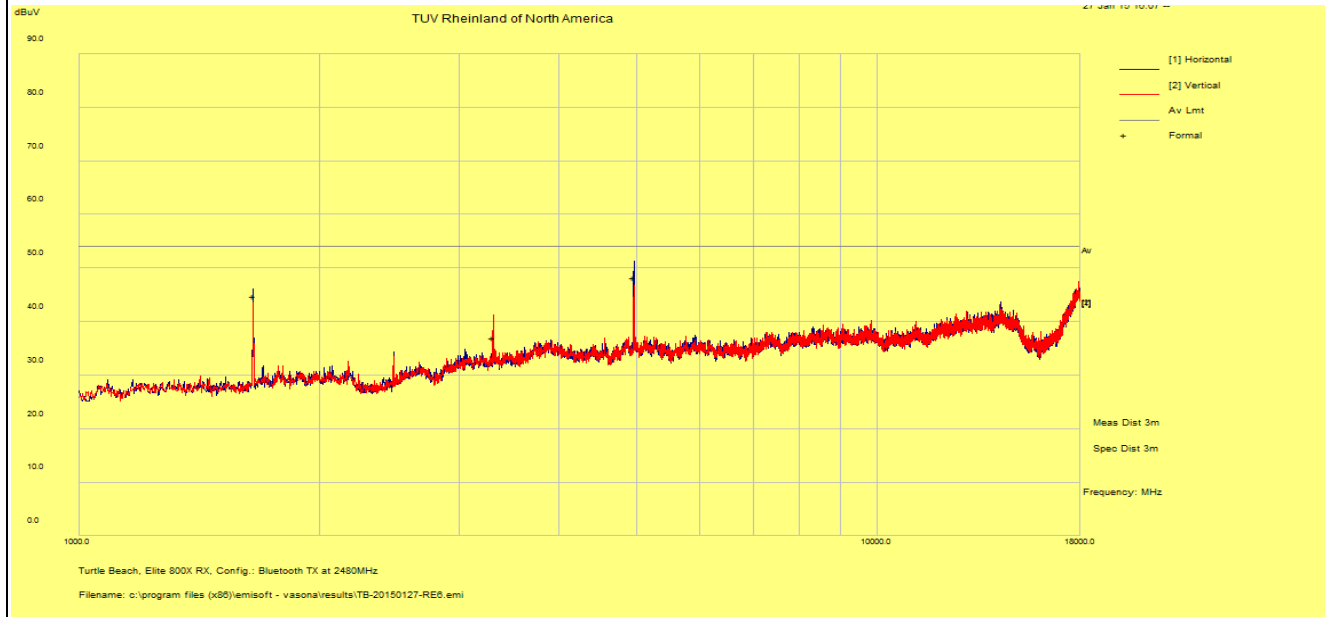

Notes: 1 GHz – 25 GHz was scanned at 1m distance.

4.6.4 Sample Calculation

The field strength is calculated by subtracting the Amplifier Gain and adding the Cable Loss and Antenna Correction Factor to the measured reading. The basic equation is as follows:

$$\text{Field Strength (dB}\mu\text{V/m)} = \text{FIM} - \text{AMP} + \text{CBL} + \text{ACF}$$

Where:

FIM = Field Intensity Meter (dB μ V)

AMP = Amplifier Gain (dB)

CBL = Cable Loss (dB)

ACF = Antenna Correction Factor (dB/m)

$$\mu\text{V/m} = 10^{\frac{\text{dB}\mu\text{V} / \text{m}}{20}}$$

4.2 AC Conducted Emissions

Testing was performed in accordance with ANSI C63.4: 2010. These test methods are listed under the laboratory's A2LA Scope of Accreditation.

This test measures the levels emanating from the EUT's AC input port, thus evaluating the potential for the EUT to cause radio frequency interference to other electronic devices.

The AC conducted emissions of equipment under test shall not exceed the values in CFR47 Part 15.207: 2013 and RSS-210: 2010.

4.2.1 Test Methodology

A test program that controls instrumentation and data logging was used to automate the AC Power Line Conducted emission test procedure. The frequency range of interest was divided into sub-ranges such as to yield a frequency resolution of 9 kHz. Each phase and neutral of the AC power line were measured with respect to ground. Measurements were performed using a set of 50 μ H / 50 Ω LISNs.

Testing is either performed in Lab 2. The setup photographs clearly identify which site was used. The vertical ground plane used in the semi-anechoic chamber is a 2m x 2m solid aluminum frame and panel, and it is bonded to the horizontal ground plane.

In the case of tabletop equipment, the EUT is placed on a 1.0m x 1.5m non-conductive table 80cm above the ground plane and 40cm from a vertical ground reference plane. The rear of the EUT was positioned flush with the backside of the table and directly over the LISNs. The power and I/O cables were routed over the edge of the table and bundled approximately 40cm from the ground plane. Support equipment was powered from a separate LISN.

4.2.1.1 Deviations

There were no deviations from this test methodology.

4.2.2 Test Results

The Elite 800X RX is powered by a 3.7 VDC battery. The AC conducted emission is not required.

4.3 Maximum Permissible Exposure

4.3.1 Test Methodology

In this section, we try to prove the safety of radiation harmfulness to the human body for our product. The KDB 447498 D01 General RF Exposure Guidance is followed. The Gain of the antenna used in this calculation is declared by the manufacturer, and the maximum average power input to the antenna is measured. Using the general SAR test exclusion guidance in Section 4.3 of KDB 447498, we show the device meeting the SAR exclusion threshold.

4.3.2 FCC KDB 447498 D01 – General SAR Test Exclusion Guidance

The SAR exclusion threshold conditions are listed:

- 1) The 1-g and 10-g SAR test exclusion thresholds for 100 MHz to 6 GHz at test separation distances ≤ 50 mm are determined by:
[(max. power of channel, including tune-up tolerance, mW)/(min. test separation distance, mm)] · $[\sqrt{f(\text{GHz})}] \leq 3.0$ for 1-g SAR and ≤ 7.5 for 10-g extremity SAR,¹⁶ where
 - f(GHz) is the RF channel transmit frequency in GHz
 - Power and distance are rounded to the nearest mW and mm before calculation¹⁷
 - The result is rounded to one decimal place for comparison

The test exclusions are applicable only when the minimum test separation distance is ≤ 50 mm and for transmission frequencies between 100 MHz and 6 GHz. When the minimum test separation distance is < 5 mm, a distance of 5 mm is applied to determine SAR test exclusion.

- 2) At 100 MHz to 6 GHz and for test separation distances > 50 mm, the SAR test exclusion threshold is determined according to the following, and as illustrated in Appendix B:
 - a) [Threshold at 50 mm in step 1) + (test separation distance - 50 mm) · (f(MHz)/150)] mW, at 100 MHz to 1500 MHz
 - b) [Threshold at 50 mm in step 1) + (test separation distance - 50 mm) · 10] mW at > 1500 MHz and ≤ 6 GHz
- 3) At frequencies below 100 MHz, the following may be considered for SAR test exclusion, and as illustrated in Appendix C:
 - a) The threshold at the corresponding test separation distance at 100 MHz in step 2) is multiplied by $[1 + \log(100/f(\text{MHz}))]$ for test separation distances > 50 mm and < 200 mm
 - b) The threshold determined by the equation in a) for 50 mm and 100 MHz is multiplied by $\frac{1}{2}$ for test separation distances ≤ 50 mm
 - c) SAR measurement procedures are not established below 100 MHz. When SAR test exclusion cannot be applied, a KDB inquiry is required to determine SAR evaluation requirements for any test results to be acceptable.

4.3.3 EUT Operating Condition

The software provided by Manufacturer enabled the EUT to transmit data at lowest, middle and highest channel individually.

4.3.4 Classification

The antenna of the product, under normal use condition, is less than 2cm away from the body of the user. This device is classified as a **Portable Device**. It is intended to be with head wear device; extremity SAR limit is applied.

4.3.5 SAR Test Exclusion Threshold

4.3.5.1 Antenna Gain

The transmitting antennas were integrated. The 2.4GHz antenna gain was +2.8 dBi or 1.91 (numeric), and the 5GHz antenna gain was +1.3 dBi or 1.35 (numeric).

4.3.5.2 SAR Exclusion Threshold Calculation

Mode	Max. Power (dBm)	EIRP (dBm)	Min. Separation Distance (mm)	Cal. Excl. Threshold	1-g SAR Limit	10-g extremity SAR Limit	Result
Bluetooth (2.4GHz)	4.54	7.34	20	0.427073	≤3.0	≤7.5	Exempted *
802.11A (5GHz)	6.98	8.28	20	0.770257	≤3.0	≤7.5	Exempted *

Note:

- Per manufacture the separation between the transmitter antenna and user is greater than 2cm. This separation distance was used for calculation per condition #1 of SAR Exclusion Threshold.
- The maximum output power was taken from Table 2.
- (*) The calculated threshold is less than 3.0; therefore, EUT is SAR exempted for head and body usage.

6 Test Equipment Use List

6.1 Equipment List

Equipment	Manufacturer	Model #	Serial/Inst #	Last Cal mm/dd/yyyy	Next Cal mm/dd/yyyy
Bilog Antenna	Sunol Sciences	JB3	A102606	07/08/2014	07/08/2016
Bilog Antenna	Sunol Sciences	JB3	A020502	04/12/2013	04/12/2015
Horn Antenna	EMCO	3115	9211-3969	03/18/2013	04/18/2015
Antenna (18-26GHz)	CMT	RA42-K-F-4B-C	020131-004	07/24/2014	07/24/2015
Spectrum Analyzer	Rohde & Schwarz	FSL6	100169	01/13/2015	01/13/2016
Spectrum Analyzer	Agilent	N9038A	MY51210195	01/12/2015	01/12/2016
Spectrum Analyzer	Agilent	N9030A	MY51380689	01/19/2015	01/19/2016
Spectrum Analyzer	Rohde Schwarz	ESIB	832427/002	01/13/2015	01/13/2016
Spectrum Analyzer	Rohde Schwarz	FSV40	1321.3008K40	11/01/2015	11/01/2016
Amplifier	Sonoma Instruments	310	213221	09/30/2014	09/30/2015
Amplifier	Miteq	TTA1800-30-4G	1842452	01/13/2015	01/13/2016
Amplifier	Rohde & Schwarz	TS-PR26	100011	07/24/2014	07/24/2016
Amplifier	Rohde & Schwarz	TS-PR40	100012	02/21/2015	02/21/2016
Power Meter	Agilent	E4418B	MY45103902	01/15/2015	01/15/2016
Power Sensor	Hewlett Packard	8482A	US37295801	01/15/2015	01/15/2016
Thermometer	Fluke	52II	96480032	06/28/2014	06/28/2015
Thermo Chamber	Espec	BTZ-133	0613436	03/16/2015	03/16/2016
DC Power Supply	Agilent	E3634A	MY400004331	01/12/2015	01/12/2016
Notch Filter	Micro-Tronics	BRM50702	37	07/18/2014	07/18/2015
Signal Generator	Anritsu	MG3694A	42803	01/13/2015	01/13/2016
Signal Generator	Rohde & Schwarz	SMF100A	1167.0000K02	10/14/2014	10/14/2015
Signal Generator	Rohde & Schwarz	SMBV100A	1407.6004K02	12/04/2014	12/04/2015
Power Sensors	Rohde & Schwarz	OSP120	1520.9010.02	12/19/2014	12/14/2015

* Calibration of equipment past due for re-calibration will be performed expeditiously. If any equipment is found to be out of tolerance at that time, affected customers will be notified accordingly.

7 EMC Test Plan

7.1 Introduction

This section provides a description of the Equipment Under Test (EUT), configurations, operating conditions, and performance acceptance criteria. It is an overview of information provided by the manufacturer so that the test laboratory may perform the requested testing.

7.2 Customer

Table 7: Customer Information

Company Name	Voyetra Turtle Beach, Inc.
Address	100 Summit Lake Drive, Suite 100
City, State, Zip	Valhalla, New York 10595
Country	U.S.A.

Table 8: Technical Contact Information

Name	Tim Blaney
E-mail	tim@commcepts.net
Phone	(530) 277-3482

7.3 Equipment Under Test (EUT)

Table 9: EUT Specifications

EUT Specifications	
Package Dimensions	252mm (9.9") x 268mm (10.5") x 134mm (5.2")
Input Voltage	Headset Input Voltage: 3.7 Vdc (battery)
Environment	Indoor
Operating Temperature Range:	0 to 50 degrees C
Multiple Feeds:	<input type="checkbox"/> Yes and how many <input checked="" type="checkbox"/> No
Hardware Version	PP V4.1
Part Number	AC4343 ES2
RF Software Version	NA
Bluetooth Radio	
Operating Mode	BDR and EDR
Transmitter Frequency Band	2402 MHz to 2480 MHz
Operating Bandwidth	1 MHz
Max. Power Output	4.54 dBm
Power Setting @ Operating Channel	BDR = 255/ 46 EDR = 255/48
Antenna Type	1 integrated PCB antenna
Antenna Gain	2.8 dBi
Modulation Type	GFSK, $\pi/4$ -DQPSK and 8DPSK
Data Rate	1 Mbps, 2Mbps, and 3Mbps
Note: This report only documents the radio characteristics for 2402 - 2480 MHz bands.	

Table 10: Interface Specifications

Interface Type	Cabled with what type of cable?	Is the cable shielded?	Maximum potential length of the cable?	Metallic (M), Coax (C), Fiber (F), or Not Applicable?
USB	USB	<input checked="" type="checkbox"/> No	<input checked="" type="checkbox"/> Metric: 1 m	<input checked="" type="checkbox"/> M

Table 11: Supported Equipment

Equipment	Manufacturer	Model	Serial	Used for
Laptop	Dell	PP23LB	9271001233	Setup EUT operating channel
Interface Board	Turtle Beach	N.A	N.A	Access 2.4GHz radio chipset
Note: None.				

Table 12: Description of Sample used for Testing

Device	Serial	RF Connection	CFR47 Part 15.247
Elite 800X RX	PP #2	Integrated Antenna	TX Emissions, Rad. Band-edge.
	PP #1	Direct via SMA Connection	Transmit Power, Occupied Bandwidth, Out of Band Emission, Hopping Requirement

Table 13: Description of Test Configuration used for Radiated Measurement.

Device	Antenna	Mode	Setup Photo (X-Axis)	Setup Photo (Y-Axis)	Setup Photo (Z-Axis)
Elite 800X RX	Integrated	Transmit	N/A	EUT upright	N/A
Note: The Elite 800X RX is designed and intended to be worn upright. All emission scans performed on the Y-Axis; worst case.					

Table 14: Final Test Mode for 2402 MHz to 2480MHz Channels

Test	802.11a
Occupied Bandwidth CFR 47 15.247(a1), RSS Gen Sect. 4.4.	2402, 2441, 2480 MHz at BDR and EDR
Output Power CFR47 15.247 (b1), RSS 210 Sect. A.8.1	2402, 2441, 2480 MHz at BDR and EDR
Out of Band Emission CFR47 15.247 (d), RSS 210 Sect. A.8.5	2402, 2441, 2480 MHz at BDR and EDR
Hopping Requirements CFR47 15.247 (a1), RSS 210 Sect. A.8.1	2402, 2441, 2480 MHz at BDR and EDR
Band-Edge (Radiated) FCC Part 15.205, 15.209	2402, 2480 MHz at BDR and EDR
Transmitted Spurious Emission (30 MHz – 1GHz) FCC Part 15.205, 15.209	2441 MHz at DH5
Transmitted Spurious Emission (Above 1GHz) FCC Part 15.205, 15.209	2402, 2441, 2480 MHz at DH5
AC Conducted Emission FCC Part 15.207	EUT is powered by a 3.7 VDC battery. Test Not required.
Note: 1. Pretest showed DH5 was the worst case.. 2. All radiated emission performed on Y-Axis. 3. All tests were pre-scanned for worst case before final testing.	

7.4 Test Specifications

Testing requirements

Table 15: Test Specifications

Emissions and Immunity	
Standard	Requirement
CFR 47 Part 15.247: 2014	All
RSS-210 Issue 8, 2010	All

END OF REPORT