

<b>Prüfbericht-Nr.:</b> <i>Test report no.:</i>	CN210K6S (P15C-2.4G) 001	<b>Auftrags-Nr.:</b> <i>Order no.:</i>	238514203	Seite 1 von 27 Page 1 of 27
<b>Kunden-Referenz-Nr.:</b> <i>Client reference no.:</i>	N/A	<b>Auftragsdatum:</b> <i>Order date:</i>	2021-04-27	
<b>Auftraggeber:</b> <i>Client:</i>	Voyetra Turtle Beach, Inc. 44 South Broadway, 4th Floor, White Plains, New York 10601, U.S.A.			
<b>Prüfgegenstand:</b> <i>Test item:</i>	Wireless gaming headset			
<b>Bezeichnung / Typ-Nr.:</b> <i>Identification / Type no.:</i>	SYN Max Air			
<b>Auftrags-Inhalt:</b> <i>Order content:</i>	FCC Part 15C Test report (2.4GHz)			
<b>Prüfgrundlage:</b> <i>Test specification:</i>	FCC 47CFR Part 15: Subpart C Section 15.247			
<b>Wareneingangsdatum:</b> <i>Date of sample receipt:</i>	2021-07-01			
<b>Prüfmuster-Nr.:</b> <i>Test sample no.:</i>	A003083728-083 A003083728-002			
<b>Prüfzeitraum:</b> <i>Testing period:</i>	2021-07-13 - 2021-07-16			
<b>Ort der Prüfung:</b> <i>Place of testing:</i>	EMC/RF Taipei Testing Site			
<b>Prüflaboratorium:</b> <i>Testing laboratory:</i>	Taipei Testing Laboratories			
<b>Prüfergebnis*:</b> <i>Test result*:</i>	Pass			
<b>überprüft von:</b> <i>compiled by:</i>		<b>genehmigt von:</b> <i>authorized by:</i>		
<b>Datum:</b> <i>Date:</i>	2021-11-04	<b>Ausstellungsdatum:</b> <i>Issue date:</i>	2021-11-04	
<b>Stellung / Position:</b>	Assistant Project Engineer	<b>Stellung / Position:</b>	Senior Project Manager	
<b>Sonstiges / Other:</b>				
<b>Zustand des Prüfgegenstandes bei Anlieferung:</b> <i>Condition of the test item at delivery:</i>	Prüfmuster vollständig und unbeschädigt <i>Test item complete and undamaged</i>			
* Legende:	1 = sehr gut P(ass) = entspricht o.g. Prüfgrundlage(n)	2 = gut F(ail) = entspricht nicht o.g. Prüfgrundlage(n)	3 = befriedigend N/A = nicht anwendbar	4 = ausreichend N/T = nicht getestet
* Legend:	1 = very good P(ass) = passed a.m. test specification(s)	2 = good F(ail) = failed a.m. test specification(s)	3 = satisfactory N/A = not applicable	4 = sufficient N/T = not tested
<b>Dieser Prüfbericht bezieht sich nur auf das o.g. Prüfmuster und darf ohne Genehmigung der Prüfstelle nicht auszugsweise vervielfältigt werden. Dieser Bericht berechtigt nicht zur Verwendung eines Prüfzeichens.</b> <i>This test report only relates to the a. m. test sample. Without permission of the test center this test report is not permitted to be duplicated in extracts. This test report does not entitle to carry any test mark.</i>				

## TEST SUMMARY

Report Section	FCC Clause	Test Item	Result
5.1.1	15.247(b) & 15.203	Antenna Requirement	Pass
5.1.2	15.247(b)(3)	Peak Output Power	Pass
5.1.3	15.247(a)(2)	6 dB Bandwidth	Pass
5.1.3	2.1049	99% Occupied Bandwidth	Pass
5.1.4	15.247(e)	Power Spectral Density	Pass
5.1.5	15.247(d)	Conducted Spurious Emissions and Band Edges	Pass
5.1.6	15.247(d) & 15.205 & 15.209	Radiated Spurious Emissions and Band Edges	Pass
5.2.1	15.207	Mains Conducted Emission	Pass

**Note:** Determining compliance based on the results of the compliance measurement, not taking into account measurement instrumentation uncertainty.

## Contents

<b>HISTORY OF THIS TEST REPORT .....</b>	<b>5</b>
<b>1. GENERAL REMARKS .....</b>	<b>6</b>
<b>1.1 COMPLEMENTARY MATERIALS.....</b>	<b>6</b>
<b>1.2 DECISION RULE OF CONFORMITY .....</b>	<b>6</b>
<b>2. TEST SITES .....</b>	<b>7</b>
<b>2.1 TEST LABORATORY .....</b>	<b>7</b>
<b>2.2 TEST FACILITY.....</b>	<b>7</b>
<b>2.3 TRACEABILITY .....</b>	<b>8</b>
<b>2.4 CALIBRATION .....</b>	<b>8</b>
<b>2.5 MEASUREMENT UNCERTAINTY .....</b>	<b>8</b>
<b>3. GENERAL PRODUCT INFORMATION.....</b>	<b>9</b>
<b>3.1 PRODUCT FUNCTION AND INTENDED USE .....</b>	<b>9</b>
<b>3.2 SYSTEM DETAILS AND RATINGS.....</b>	<b>9</b>
<b>3.3 NOISE GENERATING AND NOISE SUPPRESSING PARTS .....</b>	<b>10</b>
<b>3.4 SUBMITTED DOCUMENTS.....</b>	<b>10</b>
<b>4. TEST SET-UP AND OPERATION MODES.....</b>	<b>11</b>
<b>4.1 PRINCIPLE OF CONFIGURATION SELECTION .....</b>	<b>11</b>
<b>4.2 CARRIER FREQUENCY AND CHANNEL.....</b>	<b>11</b>
<b>4.3 TEST OPERATION AND TEST SOFTWARE.....</b>	<b>12</b>
<b>4.4 SPECIAL ACCESSORIES AND AUXILIARY EQUIPMENT .....</b>	<b>13</b>
<b>4.5 TEST SETUP DIAGRAM .....</b>	<b>14</b>
<b>5. TEST RESULTS .....</b>	<b>15</b>
<b>5.1 TRANSMITTER REQUIREMENT &amp; TEST SUITES .....</b>	<b>15</b>
5.1.1 <i>Antenna Requirement .....</i>	<i>15</i>
5.1.2 <i>Peak Output Power .....</i>	<i>16</i>
5.1.3 <i>6 dB Bandwidth and 99% Occupied Bandwidth.....</i>	<i>18</i>
5.1.4 <i>Power Spectral Density.....</i>	<i>19</i>
5.1.5 <i>Conducted Spurious Emissions and Frequency Band Edges Measured in 100kHz Bandwidth.....</i>	<i>20</i>
5.1.6 <i>Radiated Spurious Emissions and Band Edges .....</i>	<i>21</i>
<b>5.2 MAINS EMISSION .....</b>	<b>26</b>
5.2.1 <i>Mains Conducted Emission.....</i>	<i>26</i>

**Prüfbericht - Nr.: CN210K6S (P15C-2.4G) 001**  
Test Report No.

Seite 4 von 27  
Page 4 of 27

**APPENDIX A - TEST RESULT OF CONDUCTED**

**APPENDIX B - TEST RESULT OF RADIATED EMISSIONS & MAINS CONDUCTED EMISSION**

**APPENDIX SP - PHOTOGRAPHS OF TEST SETUP**

**APPENDIX EP - PHOTOGRAPHS OF EUT**

**Prüfbericht - Nr.: CN210K6S (P15C-2.4G) 001**  
Test Report No.

**Seite 5 von 27**  
Page 5 of 27

### HISTORY OF THIS TEST REPORT

Report No.	Description	Date Issued
CN210K6S (P15C-2.4G) 001	Original Release	2021-11-04

## 1. General Remarks

### 1.1 Complementary Materials

All attachments are integral parts of this test report. This applies especially to the following appendix:

**Appendix A - Test Result of Conducted**

**Appendix B - Test Result of Radiated Emissions & Mains Conducted Emission**

**Appendix SP - Photographs of Test Setup**

**Appendix EP - Photographs of EUT**

### Applied Standard and Test Levels

Radio
FCC 47CFR Part 15: Subpart C Section 15.247
FCC 47CFR Part 2: Subpart J Section 2.1049
ANSI C63.10:2013
KDB 558074 D01 15.247 Meas Guidance v05r02

### 1.2 Decision Rule of Conformity

The decision rule of conformity of this test report is following the requirements of the requested standard in the quotation, and agreed among testing laboratory and manufacturer (applicant) to exclude the consideration of Measurement Uncertainty, unless it is required by the specific standard.

## 2. Test Sites

### 2.1 Test Laboratory

Taipei Testing Laboratories

11F. No.758, Sec. 4, Bade Rd., Songshan Dist.  
Taipei City 105  
Taiwan (R.O.C.)

### 2.2 Test Facility

Taipei Testing Laboratories

No.458-18, Sec. 2, Fenliao Rd., Linkou Dist.,  
New Taipei City 244  
Taiwan (R.O.C.)  
FCC Registration No.: 226631  
ISED Registration No.: 25563

## 2.3 Traceability

All measurement equipment calibrations are traceable to NML(Taiwan)/NIST(USA) or where calibration is performed outside Taiwan, to equivalent nationally recognized standards organizations.

## 2.4 Calibration

Equipment requiring calibration is calibrated periodically in a suitably accredited Calibration Lab. Additionally all equipment is verified for proper performance on a regular basis using in house standards or comparisons.

## 2.5 Measurement Uncertainty

All measurement uncertainty values are shown with a coverage factor of  $k=2$  to indicate a 95% level of confidence.

### Emission Measurement Uncertainty

Parameter	Uncertainty
Radiated Emission (9 kHz ~ 30 MHz)	$\pm 1.15$ dB
Radiated Emission (30 MHz ~ 200 MHz)	$\pm 1.30$ dB
Radiated Emission (200 MHz ~ 1 GHz)	$\pm 1.30$ dB
Radiated Emission (1 GHz ~ 18 GHz)	$\pm 1.54$ dB
Radiated Emission (18 GHz ~ 40 GHz)	$\pm 2.52$ dB
Mains Conducted Emission	$\pm 1.65$ dB



### 3. General Product Information

#### 3.1 Product Function and Intended Use

The EUT is a Wireless gaming headset. It contains a 2.4GHz compatible module enabling the user to communicate data through a Wireless interface.

For details refer to the User Guide, Data Sheet and Circuit Diagram.

#### 3.2 System Details and Ratings

##### Basic Information of EUT

Item	EUT Information
Kind of Equipment/Test Item	Wireless gaming headset
Type Identification	SYN Max Air
FCC ID	XGB-14155

##### Technical Specification of EUT

Item	EUT Information
Operating Frequency	2402 MHz ~ 2480 MHz
Channel Number	40
Data Rate	1Mbps, 2Mbps
Operation Voltage	3.7 Vdc (Battery) 5 Vdc (USB)
Modulation	GFSK
Maximum Output Power (mW)	2.27
Antenna Information	Refer to 5.1.1
Accessory Device	Refer to 4.4

### **3.3 Noise Generating and Noise Suppressing Parts**

Refer to the Circuit Diagram.

### **3.4 Submitted Documents**

- Circuit Diagram
- Instruction Manual
- Rating Label
- Technical Description

## 4. Test Set-up and Operation Modes

### 4.1 Principle of Configuration Selection

The test modes were adapted accordingly in reference to the instructions for use.

During testing, Channel and Power Controlling Software provided by the customer was used to control the operating channel as well as the output power level. The RF output power selection is for the setting of RF output expected by the customer and is going to be fixed on the firmware of the final end product.

**Table for Parameters of Test Software Setting**

Frequency (MHz)	Power Setting	
	1Mbps	2Mbps
2402	2	4
2440	4	4
2480	4	4

### 4.2 Carrier Frequency and Channel

Channel	Freq. (MHz)	Channel	Freq. (MHz)	Channel	Freq. (MHz)	Channel	Freq. (MHz)
0	2402	10	2422	20	2442	30	2462
1	2404	11	2424	21	2444	31	2464
2	2406	12	2426	22	2446	32	2466
3	2408	13	2428	23	2448	33	2468
4	2410	14	2430	24	2450	34	2470
5	2412	15	2432	25	2452	35	2472
6	2414	16	2434	26	2454	36	2474
7	2416	17	2436	27	2456	37	2476
8	2418	18	2438	28	2458	38	2478
9	2420	19	2440	29	2460	39	2480

### 4.3 Test Operation and Test Software

Setup for testing: Test samples are provided with an USB interface which makes it possible to control them through a test software installed on a notebook computer.

This software was running on the laptop computer connected to the EUT. It was used to enable the operation modes listed as below.

Test Software	TestCommonUT
---------------	--------------

The samples were used as follows:

A003083728-083

A003083728-002

Full test was applied on all test modes, but only worst case was shown.

EUT Configure Mode	Applicable To			Mains Conducted Emission	Description
	Antenna Port Conducted Measurement	Radiated Spurious Emissions above 1 GHz	Radiated Spurious Emissions below 1 GHz		
-	√	√	√	√	-

Note:

1. The EUT had been pre-tested on the positioned of each 3 axis. The worst case was found when position on **Y-plane**.
2. "-" means no effect.

#### Antenna Port Conducted Measurement

Pre-Scan full test was applied on all test modes, but only worst case was shown.

Following channel(s) was (were) selected for the final test as listed below.

EUT Configure Mode	Available Frequency (MHz)	Tested Frequency (MHz)	Date Rate (Mbps)
-	2402 to 2480	2402, 2440, 2480	1
-	2402 to 2480	2402, 2440, 2480	2

#### Radiated Spurious Emissions (Above 1 GHz)

Pre-Scan full test was applied on all test modes, but only worst case was shown.

Following channel(s) was (were) selected for the final test as listed below.

EUT Configure Mode	Available Frequency (MHz)	Tested Frequency (MHz)	Date Rate (Mbps)
-	2402 to 2480	2402, 2440, 2480	1
-	2402 to 2480	2402, 2440, 2480	2

#### Radiated Spurious Emissions (Below 1 GHz)

Pre-Scan full test was applied on all test modes, but only worst case was shown.

Following channel(s) was (were) selected for the final test as listed below.

EUT Configure Mode	Available Frequency (MHz)	Tested Frequency (MHz)	Date Rate (Mbps)
-	2402 to 2480	2402	1

#### Mains Conducted Emission

Pre-Scan full test was applied on all test modes, but only worst case was shown.

Following channel(s) was (were) selected for the final test as listed below.

EUT Configure Mode	Available Frequency (MHz)	Tested Frequency (MHz)	Date Rate (Mbps)
-	2402 to 2480	2402	1

**Test Condition**

Test Item	Ambient Temperature	Relative Humidity	Tested by
Conducted Measurement	18-23 °C	58-69 %	Nick Hsu
Radiated Spurious Emissions above 1 GHz	24.5-26.5 °C	57-62 %	Eagle Tsai
Radiated Spurious Emissions below 1 GHz	24.5-26.5 °C	57-62 %	Eagle Tsai
Mains Conducted Emission	19.5 °C	61 %	Temo Chen

## 4.4 Special Accessories and Auxiliary Equipment

The product has been tested together with the following additional accessories:

**Accessory of EUT**

No.	Product	Brand	Model	Description
A	USB Cable 1 (A to C)	ROCCAT	SYN Max Air	150 cm shielded cable w/o core
-	USB Cable 2 (C to C)	ROCCAT	SYN Max Air	150 cm shielded cable w/o core
-	USB C to USB A Adapter	ROCCAT	SYN Max Air	--
-	Battery	FUTURE POWER	FT593545P	3.7 Vdc

**Support Unit**

Support Unit								
No	Description	Brand	Model	S/N	Shielded	Ferrite Core (Qty)	Length (cm)	Remark
1	Notebook	HP	15s-du0007TX	CND93662VF	-	-	-	--
2	Adapter	HP	TPN-CA16	N/A	NO	NO	180	--

## 4.5 Test Setup Diagram

<Radiated Spurious Emissions mode>

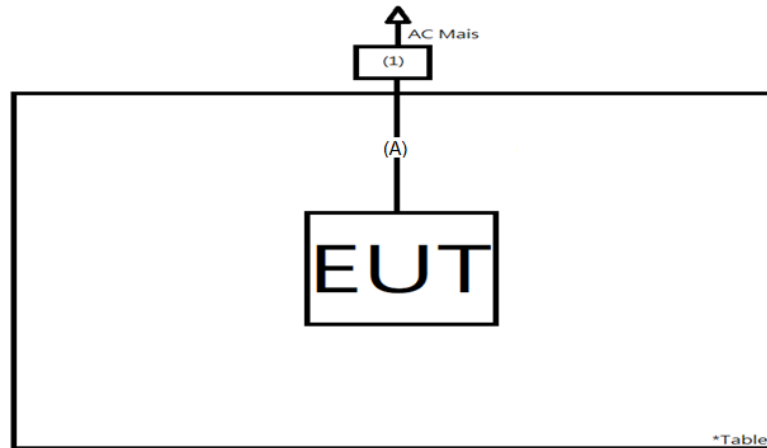

<Mains Conducted Emission mode>

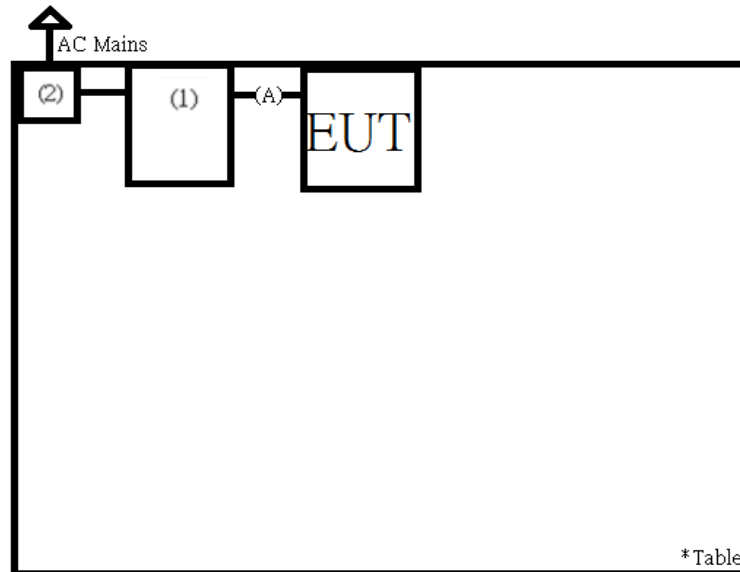

## 5. Test Results

### 5.1 Transmitter Requirement & Test Suites

#### 5.1.1 Antenna Requirement

**Requirement** Use of approved antennas only

According to the manufacturer declaration, the EUT has an antenna with a directional gain of 4.5 dBi. The antenna is FPCB antenna with no possibility of replacement with a non-approved antenna by the end-user. Therefore, the EUT is considered to comply with this provision.

Refer to EUT photo for details.

### 5.1.2 Peak Output Power

**Limit** 1 watt (30 dBm)

**Kind of Test Site** Shielded room

**Test Setup**

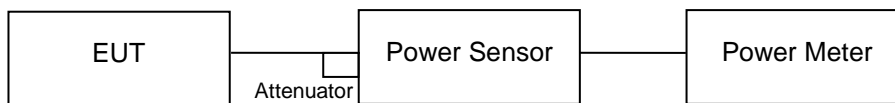

**Test Instruments**

Kind of Equipment	Manufacturer	Type	S/N	Calibration Date	Calibration Due Date	Test Date	
						From	Until
Power Meter	Anritsu	ML2495A	1901008	2021/3/24	2022/3/23	2021/7/13	2021/7/16
Power Sensor	Anritsu	MA2411B	1725269	2021/3/24	2022/3/23	2021/7/13	2021/7/16

**Test Procedures**

A peak power sensor was used on the output port of the EUT. A power meter was used to read the response of the peak power sensor. Record the power level.

Average power sensor was used to perform output power measurement, trigger and gating function of wide band power meter is enabled to measure max output power of TX on burst. Duty factor is not added to measured value.



**Test Result**
**Peak Output Power**
**<1Mbps>**

Channel	Channel Frequency	Peak Output Power		Limit (dBm)
	(MHz)	(dBm)	(mW)	
Low Channel	2402	2.43	1.75	30
Middle Channel	2440	3.39	2.18	30
High Channel	2480	3.25	2.11	30

**<2Mbps>**

Channel	Channel Frequency	Peak Output Power		Limit (dBm)
	(MHz)	(dBm)	(mW)	
Low Channel	2402	3.56	2.27	30
Middle Channel	2440	3.41	2.19	30
High Channel	2480	3.26	2.12	30

**Average Power**
**<1Mbps>**

Channel	Channel Frequency	Average Power	
	(MHz)	(dBm)	(mW)
Low Channel	2402	2.40	1.74
Middle Channel	2440	3.37	2.17
High Channel	2480	3.23	2.10

**<2Mbps>**

Channel	Channel Frequency	Average Power	
	(MHz)	(dBm)	(mW)
Low Channel	2402	3.53	2.25
Middle Channel	2440	3.37	2.17
High Channel	2480	3.23	2.10

### 5.1.3 6 dB Bandwidth and 99% Occupied Bandwidth

**Limit** The minimum 6 dB bandwidth shall be at least 500 kHz.

**Kind of Test Site** Shielded room

#### Test Setup

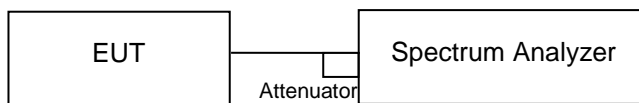

#### Test Instruments

Kind of Equipment	Manufacturer	Type	S/N	Calibration Date	Calibration Due Date	Test Date	
						From	Until
Spectrum Analyzer	R&S	FSV40	101512	2021/1/29	2022/1/28	2021/7/13	2021/7/16

#### Test Procedure

- Set resolution bandwidth (RBW) = 100 kHz
- Set the video bandwidth (VBW)  $\geq 3 \times$  RBW, Detector = Peak.
- Trace mode = max hold.
- Sweep = auto couple.
- Measure the maximum width of the emission that is constrained by the frequencies associated with the two amplitude points (upper and lower) that are attenuated by 6 dB relative to the maximum level measured in the fundamental emission.
- For 99% occupied bandwidth measurement, the transmitter output was connected to the spectrum analyzer through an attenuator. The bandwidth of the fundamental frequency was measured by spectrum analyzer with resolution bandwidth in the range of 1% to 5% of the anticipated emission bandwidth, and a video bandwidth at least 3x the resolution bandwidth and set the detector to PEAK. The width of a frequency band such that, below the lower and above the upper frequency limits, the mean powers emitted are each equal to a specified percentage 0.5% of the total mean power of a given emission.

#### Test Results

Please refer to Appendix A.

### 5.1.4 Power Spectral Density

#### Limit

The power spectral density shall not be greater than 8 dBm in any 3 kHz band.

**Kind of Test Site**                      Shielded room

#### Test Setup

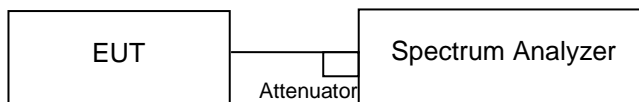

#### Test Instruments

Kind of Equipment	Manufacturer	Type	S/N	Calibration Date	Calibration Due Date	Test Date	
						From	Until
Spectrum Analyzer	R&S	FSV40	101512	2021/1/29	2022/1/28	2021/7/13	2021/7/16

#### Test Procedure

- a. Set analyzer center frequency to DTS channel center frequency.
- b. Set the span to 1.5 times the DTS bandwidth.
- c. Set the RBW to:  $3 \text{ kHz} \leq \text{RBW} \leq 100 \text{ kHz}$ .
- d. Set the VBW  $\geq 3 \times \text{RBW}$ .
- e. Detector = peak.
- f. Sweep time = auto couple.
- g. Trace mode = max hold.
- h. Allow trace to fully stabilize.
- i. Use the peak marker function to determine the maximum amplitude level within the RBW.

#### Test Results

Please refer to Appendix A.

## 5.1.5 Conducted Spurious Emissions and Frequency Band Edges Measured in 100kHz Bandwidth

### Limit

20dB (below that in the 100 kHz bandwidth within the band that contains the highest level of the desired power.)

**Kind of Test Site**                      Shielded room

### Test Setup

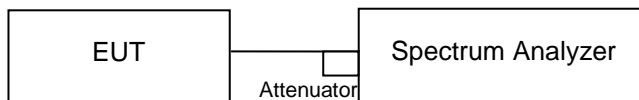

### Test Instruments

Kind of Equipment	Manufacturer	Type	S/N	Calibration Date	Calibration Due Date	Test Date	
						From	Until
Spectrum Analyzer	R&S	FSV40	101512	2021/1/29	2022/1/28	2021/7/13	2021/7/16

### Test Procedure

Measurement procedure REF

1. Set the RBW = 100 kHz.
2. Set the VBW  $\geq$  300 kHz.
3. Detector = peak.
4. Sweep time = auto couple.
5. Trace mode = max hold.
6. Allow trace to fully stabilize.
7. Use the peak marker function to determine the maximum power level in any 100 kHz band segment within the fundamental EBW.

Measurement procedure OOBE

1. Set RBW = 100 kHz.
2. Set VBW  $\geq$  300 kHz.
3. Detector = peak.
4. Sweep = auto couple.
5. Trace Mode = max hold.
6. Allow trace to fully stabilize.
7. Use the peak marker function to determine the maximum amplitude level.

### Test Results

Please refer to Appendix A.

## 5.1.6 Radiated Spurious Emissions and Band Edges

### Limit

Radiated emissions which fall in the restricted bands, as defined in §15.205(a), must comply with the radiated emission limits specified in §15.209(a).

Emissions radiated outside the restricted and authorized frequency bands must either comply with the radiated emission limits specified for the restricted bands or in §15.247(d).

**Kind of Test Site**                      3m Semi-Anechoic Chamber

### Test Setup

<Radiated Emissions below 30 MHz>

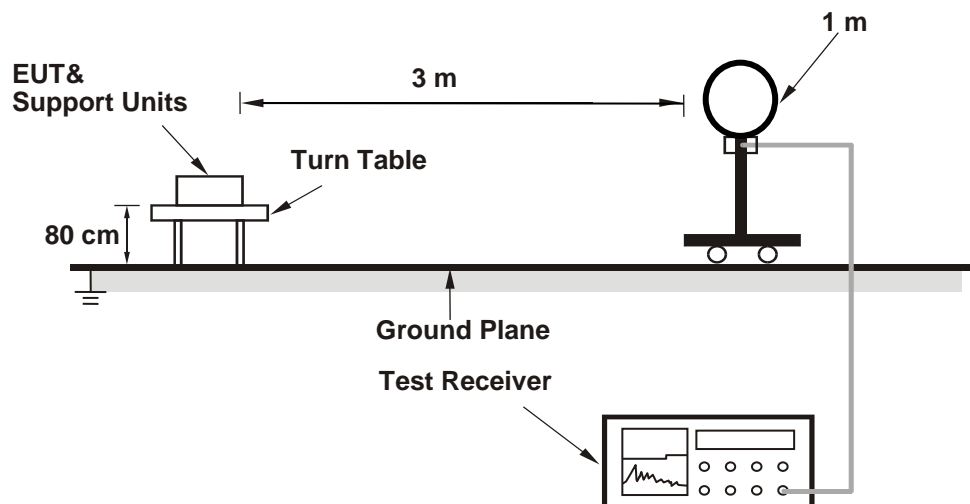

<Radiated Emissions 30 MHz to 1 GHz>

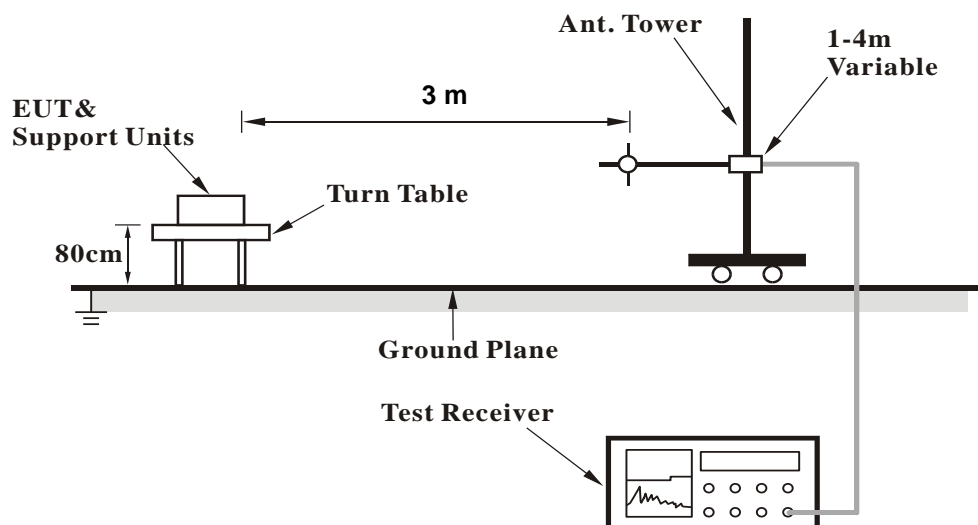

## &lt;Radiated Emissions above 1 GHz&gt;

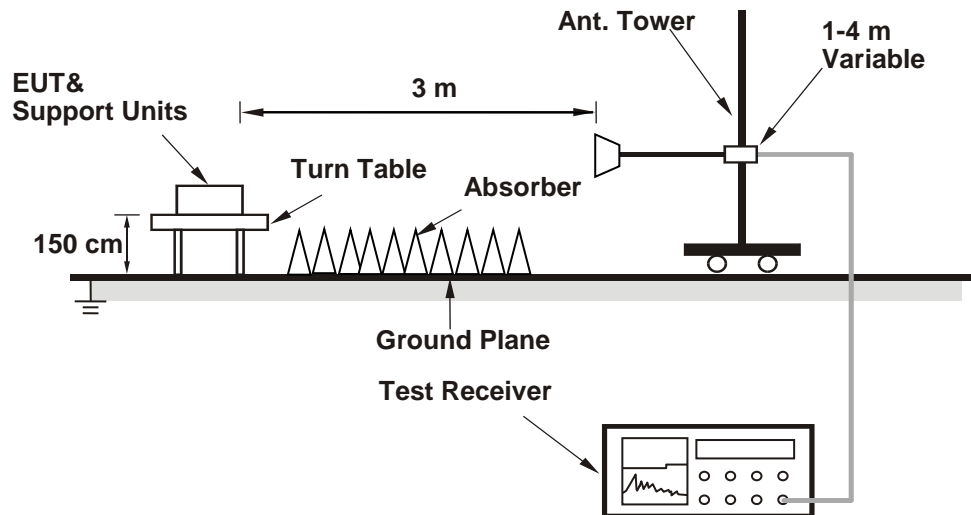

For the actual test configuration, please refer to the attached file (Test Setup Photo).

**Test Instruments**

Kind of Equipment	Manufacturer	Type	S/N	Calibration Date	Calibration Due Date
Signal Analyzer	R&S	FSV40	101508	2021/3/16	2022/3/15
Receiver	R&S	ESR7	102109	2021/3/16	2022/3/15
Bilog Antenna	SCHWARZBECK	VULB-9168	00951	2021/2/18	2022/2/17
Horn Antenna	ETS-Lindgren	3117	00218930	2020/12/1	2021/11/30
LF-AMP	Agilent	8447D	2944A10772	2021/2/18	2022/2/17
HF-AMP + AC source	EMCI	EMC051845SE	980633	2021/2/9	2022/2/8
HF-AMP + AC source	EMCI	EMC184045SE	980657	2021/2/1	2022/1/31
Horn Antenna	SCHWARZBECK	BBHA 9170	00887	2021/4/8	2022/4/7
Microwave Cable	HUBER+SUHNER	SUCOFLEX 104EA	800056/4EA	2021/3/17	2022/3/16
Microwave Cable	HUBER+SUHNER	SUCOFLEX 104	804680/4	2021/3/17	2022/3/16
Microwave Cable	HUBER+SUHNER	SUCOFLEX 104	MY37202/4	2021/3/17	2022/3/16
Microwave Cable	HUBER+SUHNER	SUCOFLEX 102EA	800898/2EA	2021/4/16	2022/4/15
Microwave Cable	HUBER+SUHNER	SUCOFLEX 102EA	800901/2EA	2021/4/16	2022/4/15
Microwave Cable	HUBER+SUHNER	SUCOFLEX 102EA	801027/2EA	2021/4/16	2022/4/15
Loop Antenna	Chance Most	EMCILPA600 +calibration	287	2021/1/15	2022/1/14

**Test Procedures****For Radiated Emissions below 30 MHz**

- a. The EUT was placed on the top of a rotating table 0.8 meters above the ground at a 3 meter chamber room. The table was rotated 360 degrees to determine the position of the highest radiation.
- b. The EUT was set 3 meters away from the interference-receiving antenna, which was mounted on the top of a variable-height antenna tower.
- c. Parallel (OPEN), perpendicular (CLOSE), and ground-parallel (GROUND) orientations of the antenna are set to make the measurement.
- d. For each suspected emission, the EUT was arranged to its worst case and the rotatable table was turned from 0 degrees to 360 degrees to find the maximum reading.
- e. The test-receiver system was set to Quasi-Peak Detect Function and Specified Bandwidth with Maximum Hold Mode.

## Note:

1. The resolution bandwidth and video bandwidth of test receiver/spectrum analyzer is 9 kHz at frequency below 30 MHz.
2. All modes of operation were investigated and the worst-case emissions are reported.

**For Radiated Emissions above 30 MHz**

- a. The EUT was placed on the top of a rotating table 0.8 meters (for 30 MHz ~ 1 GHz) / 1.5 meters (for above 1 GHz) above the ground at 3 meter chamber room for test. The table was rotated 360 degrees to determine the position of the highest radiation.
- b. The EUT was set 3 meters away from the interference-receiving antenna, which was mounted on the top of a variable-height antenna tower.
- c. The height of antenna is varied from one meter to four meters above the ground to determine the maximum value of the field strength. Both horizontal and vertical polarizations of the antenna are set to make the measurement.
- d. For each suspected emission, the EUT was arranged to its worst case and then the antenna was tuned to heights from 1 meter to 4 meters and the rotatable table was turned from 0 degrees to 360 degrees to find the maximum reading.
- e. The test-receiver system was set to quasi-peak detect function and specified bandwidth with maximum hold mode when the test frequency is below 1 GHz.
- f. The test-receiver system was set to peak and average detected function and specified bandwidth with maximum hold mode when the test frequency is above 1 GHz. If the peak reading value also meets average limit, measurement with the average detector is unnecessary.

## Note:

1. The resolution bandwidth and video bandwidth of test receiver/spectrum analyzer is 120 kHz for Quasi-peak detection (QP) or Peak detection (PK) at frequency below 1 GHz.
2. The resolution bandwidth of test receiver/spectrum analyzer is 1 MHz and the video bandwidth is 3 MHz for Peak detection (PK) at frequency above 1 GHz.
3. The resolution bandwidth of test receiver/spectrum analyzer is 1 MHz and the video bandwidth is  $\geq 1/T$  (Duty cycle < 98 %) or 10 Hz (Duty cycle  $\geq 98$  %) for Average detection (AV) at frequency above 1 GHz.
4. All modes of operation were investigated and the worst-case emissions are reported.
5. The Radiated Emissions testing was performed in the X(E1), Y(H) and Z(E2) axis orientation. The worst-case Axis orientation is recorded in this test report.



**Prüfbericht - Nr.: CN210K6S (P15C-2.4G) 001**  
*Test Report No.*

**Seite 25 von 27**  
*Page 25 of 27*

**Test Results**

Factor (dB/m) = Antenna Factor (dB/m) + Cable Loss (dB)  
Level (dBuV/m) = Reading (dBuV) + Factor (dB/m)

Please refer to Appendix B.

## 5.2 Mains Emission

### 5.2.1 Mains Conducted Emission

#### Limit

Mains Conducted Emission as defined in §15.207 must comply with the mains conducted emission limits.

**Kind of Test Site**                      Shielded room

#### Test Setup

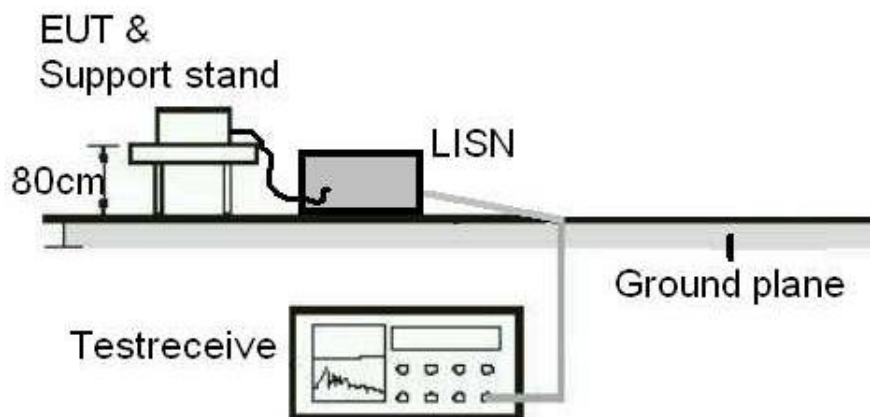

#### Test Instruments

Kind of Equipment	Manufacturer	Type	S/N	Calibration Date	Calibration Due Date
TWO-LINE V-NETWORK	R&S	ENV216	1816064	2020/9/10	2021/9/9
EMI Test Receiver	R&S	ESCI	1816063	2020/11/17	2021/11/16
RF Cable	N/A	N/A	EMC-003	2020/11/15	2021/11/14

#### **Test Procedures**

- a. The EUT was placed 0.4 meters from the conducting wall of the shielded room with EUT being connected to the power mains through a line impedance stabilization network (LISN). Other support units were connected to the power mains through another LISN. The two LISNs provide 50 ohm/50 uH of coupling impedance for the measuring instrument.
- b. Both lines of the power mains connected to the EUT were checked for maximum conducted interference.
- c. The frequency range from 150 kHz to 30 MHz was searched. Emission levels under (Limit – 20 dB) was not recorded.

Note: The resolution bandwidth and video bandwidth of test receiver is 9 kHz for quasi-peak detection (QP) and average detection (AV) at frequency 0.15 MHz – 30 MHz.

#### **Test Results**

Please refer to Appendix B.

# Appendix A: Test Results of Conducted Test

## Test Result of 6 dB Bandwidth

### 1Mbps

Channel	Channel Frequency (MHz)	6 dB Bandwidth (kHz)	Limit (kHz)	Result
Low Channel	2402	731.27	> 500	Pass
Middle Channel	2440	725.27	> 500	Pass
High Channel	2480	746.25	> 500	Pass

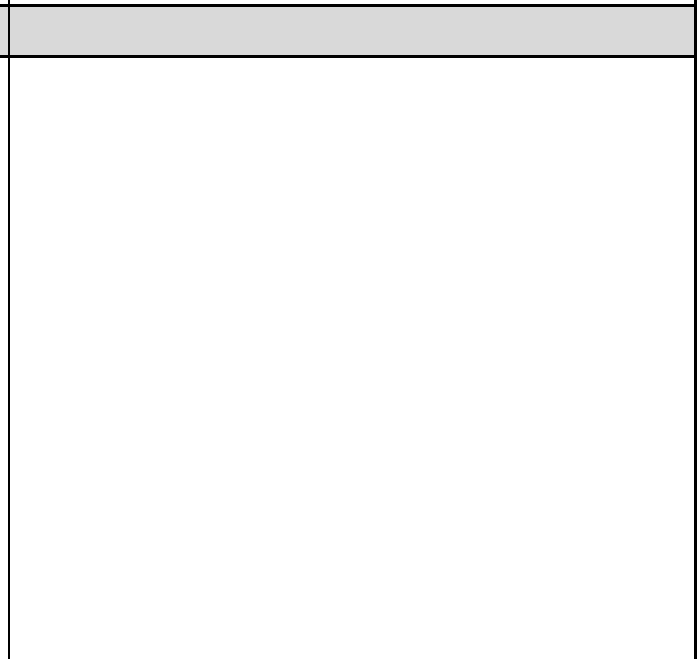
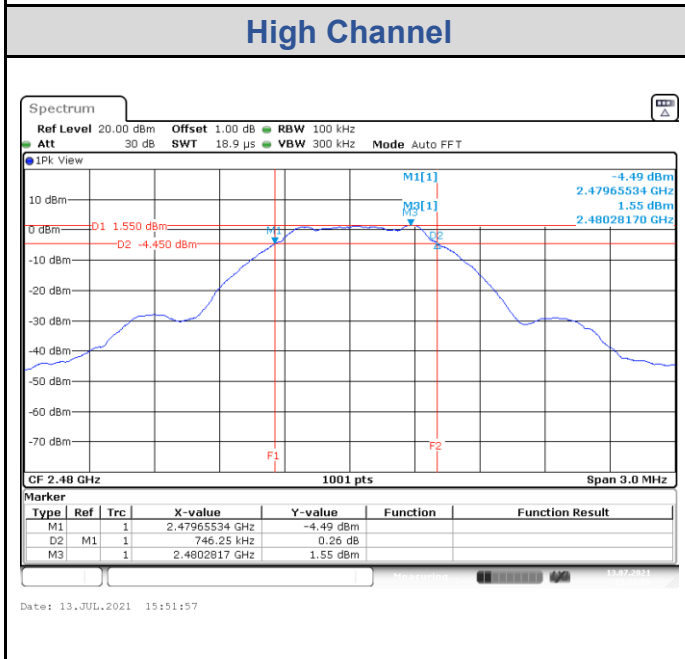
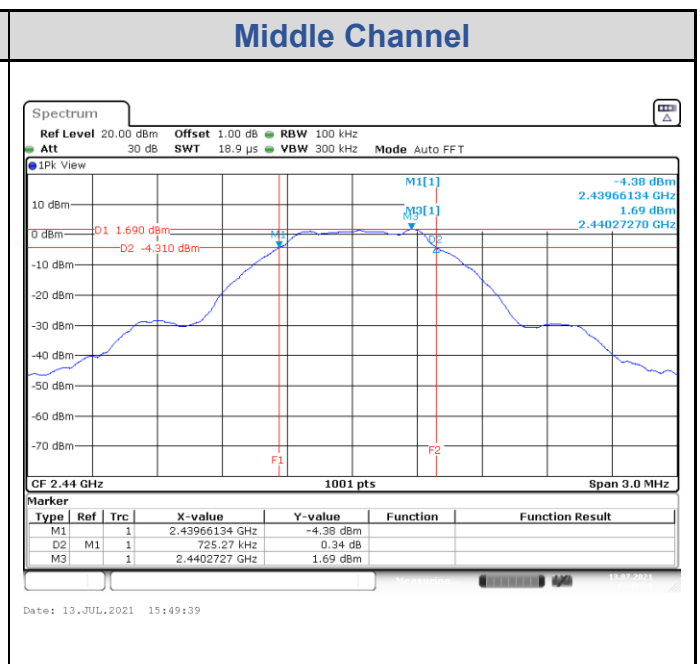
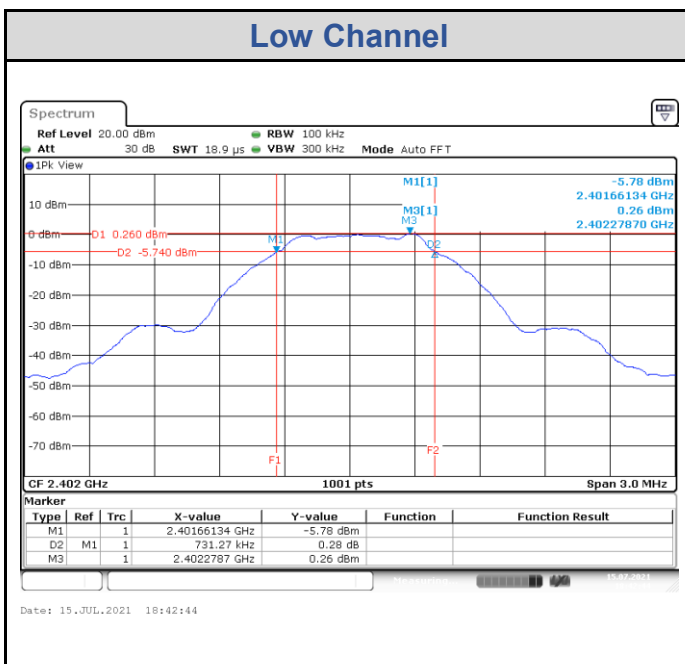

**2Mbps**

Channel	Channel Frequency (MHz)	6 dB Bandwidth (kHz)	Limit (kHz)	Result
Low Channel	2402	1388.61	> 500	Pass
Middle Channel	2440	1383.62	> 500	Pass
High Channel	2480	1393.61	> 500	Pass

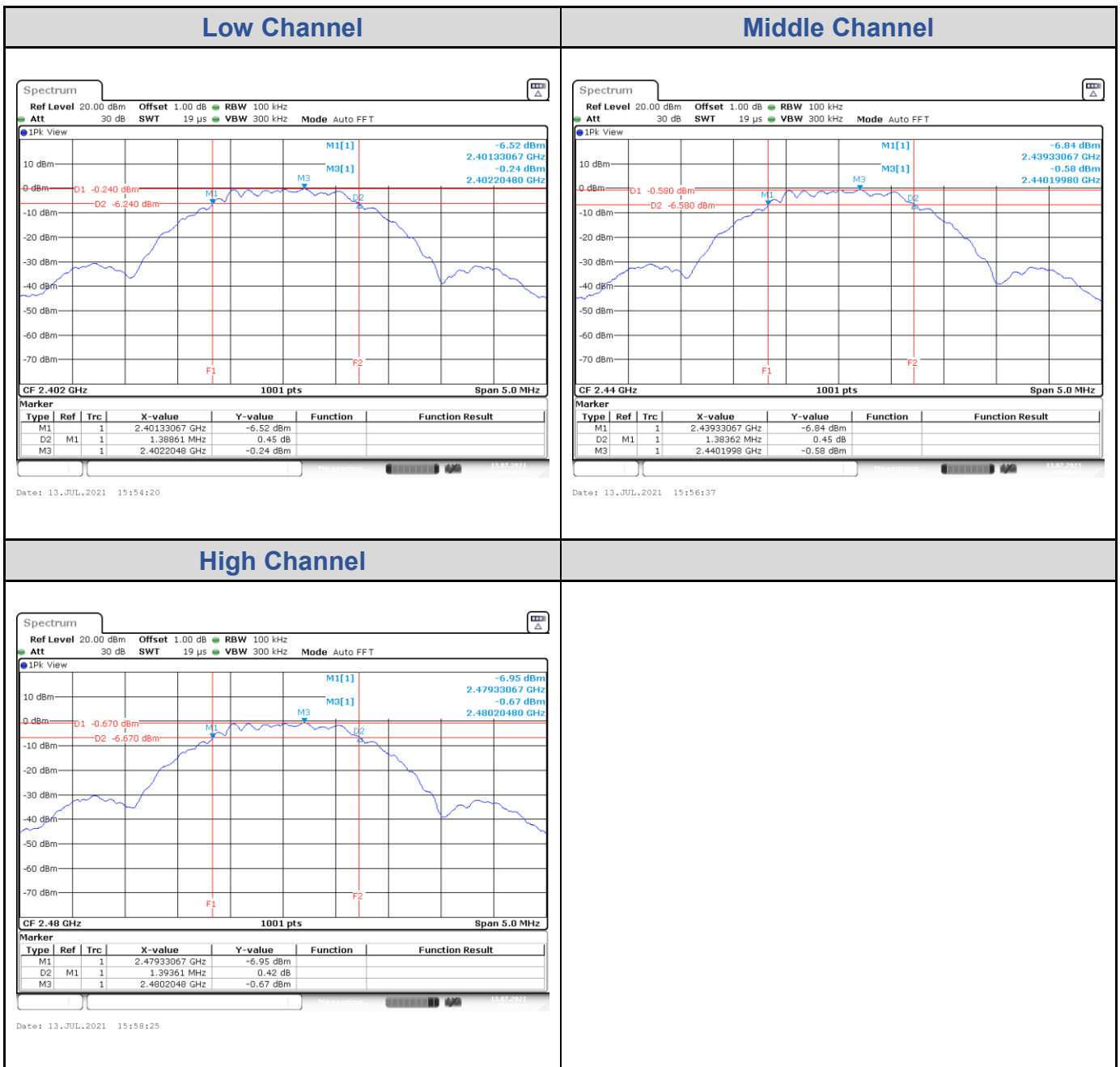

## Test Result of 99% Occupied Bandwidth

### 1Mbps

Channel	Channel Frequency (MHz)	99% Bandwidth (MHz)
Low Channel	2402	1.034
Middle Channel	2440	1.034
High Channel	2480	1.040

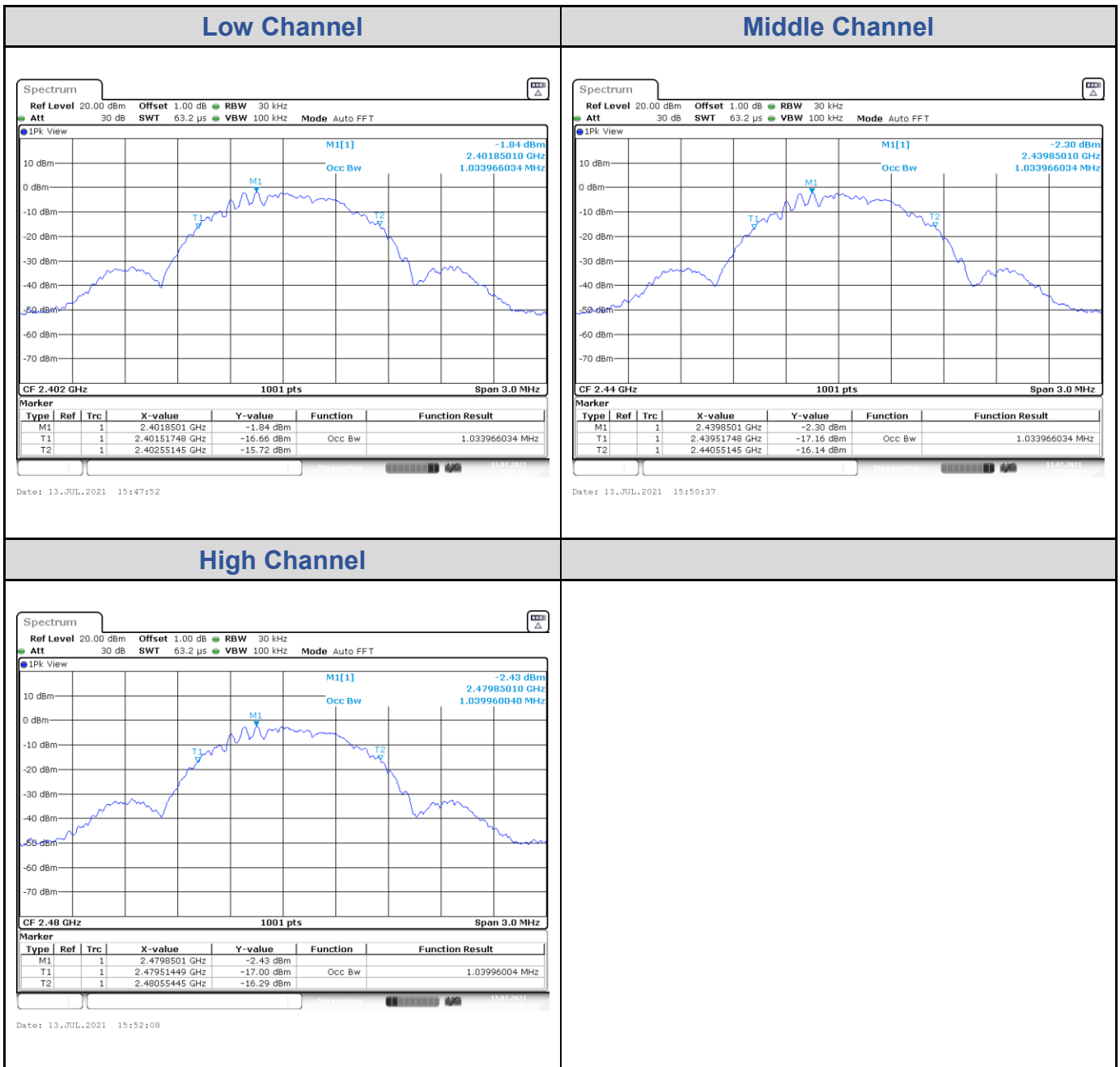

**2Mbps**

Channel	Channel Frequency (MHz)	99% Bandwidth (MHz)
Low Channel	2402	2.038
Middle Channel	2440	2.038
High Channel	2480	2.053

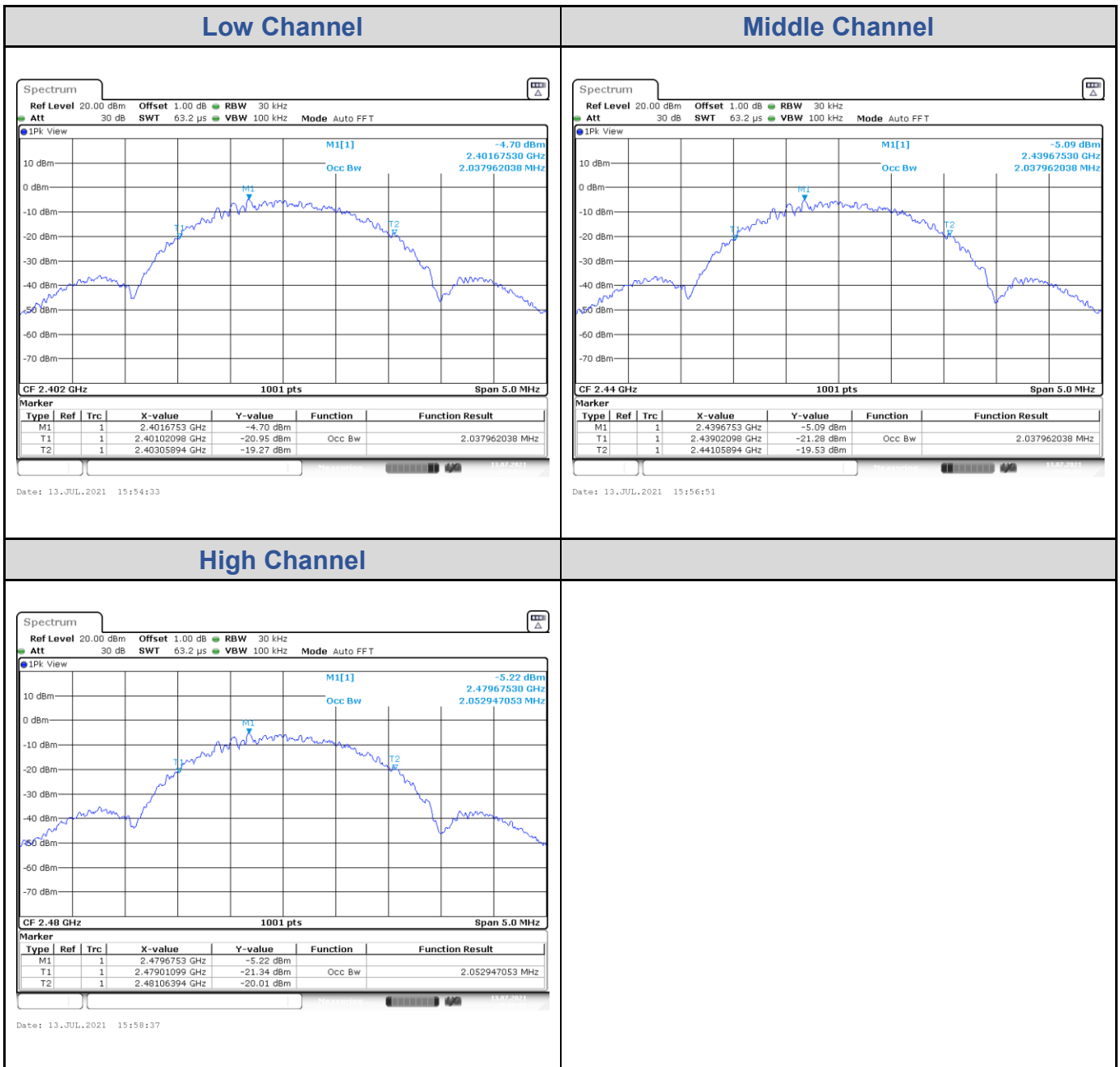

## Test Result of Power Spectral Density

**1Mbps**

Channel	Channel Frequency (MHz)	Power Density (dBm/3kHz)	Limit (dBm/3kHz)	Result
Low Channel	2402	-13.37	8	Pass
Middle Channel	2440	-13.57	8	Pass
High Channel	2480	-13.74	8	Pass

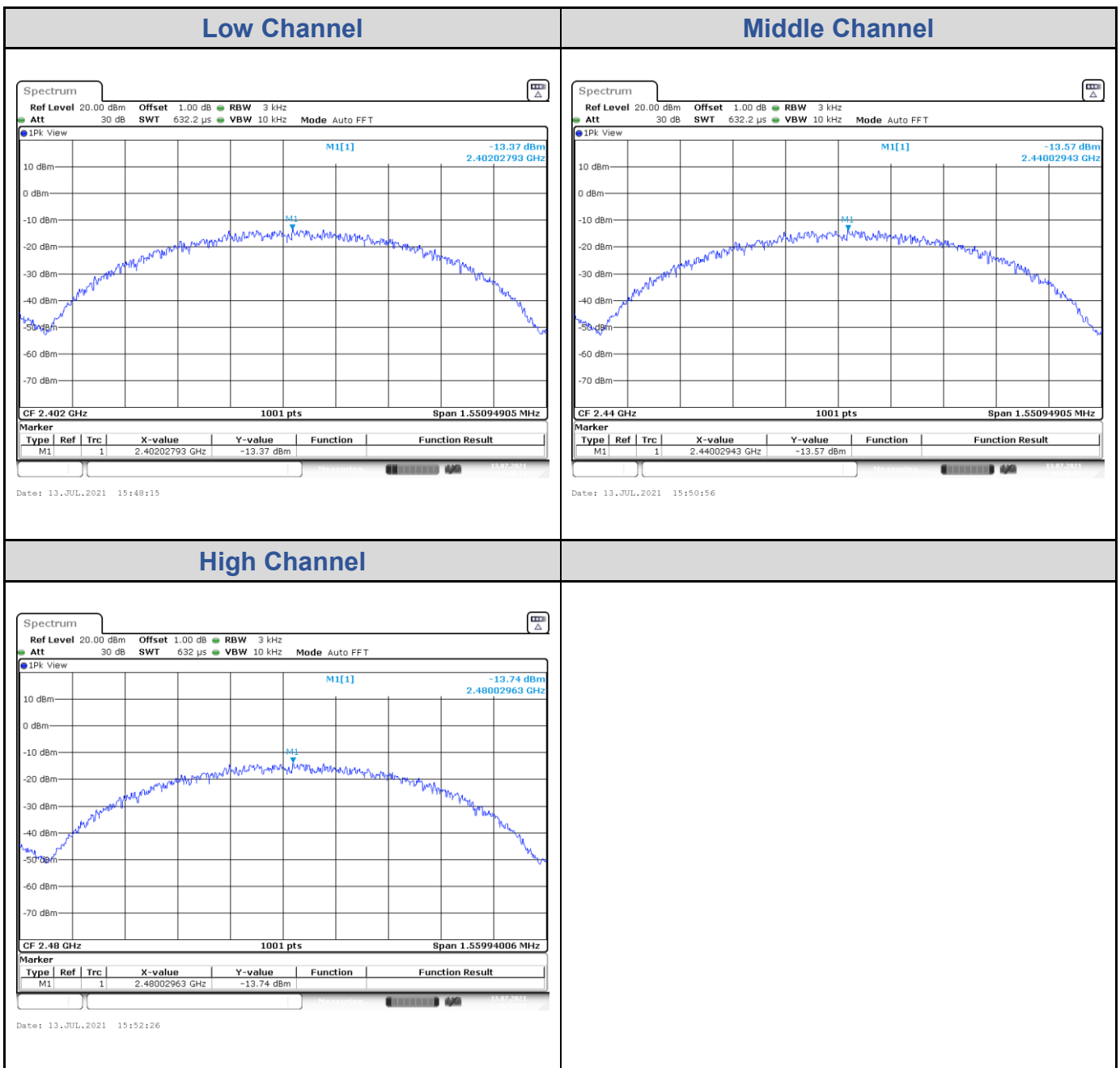



**2Mbps**

Channel	Channel Frequency (MHz)	Power Density (dBm/3kHz)	Limit (dBm/3kHz)	Result
Low Channel	2402	-18.31	8	Pass
Middle Channel	2440	-18.43	8	Pass
High Channel	2480	-18.61	8	Pass

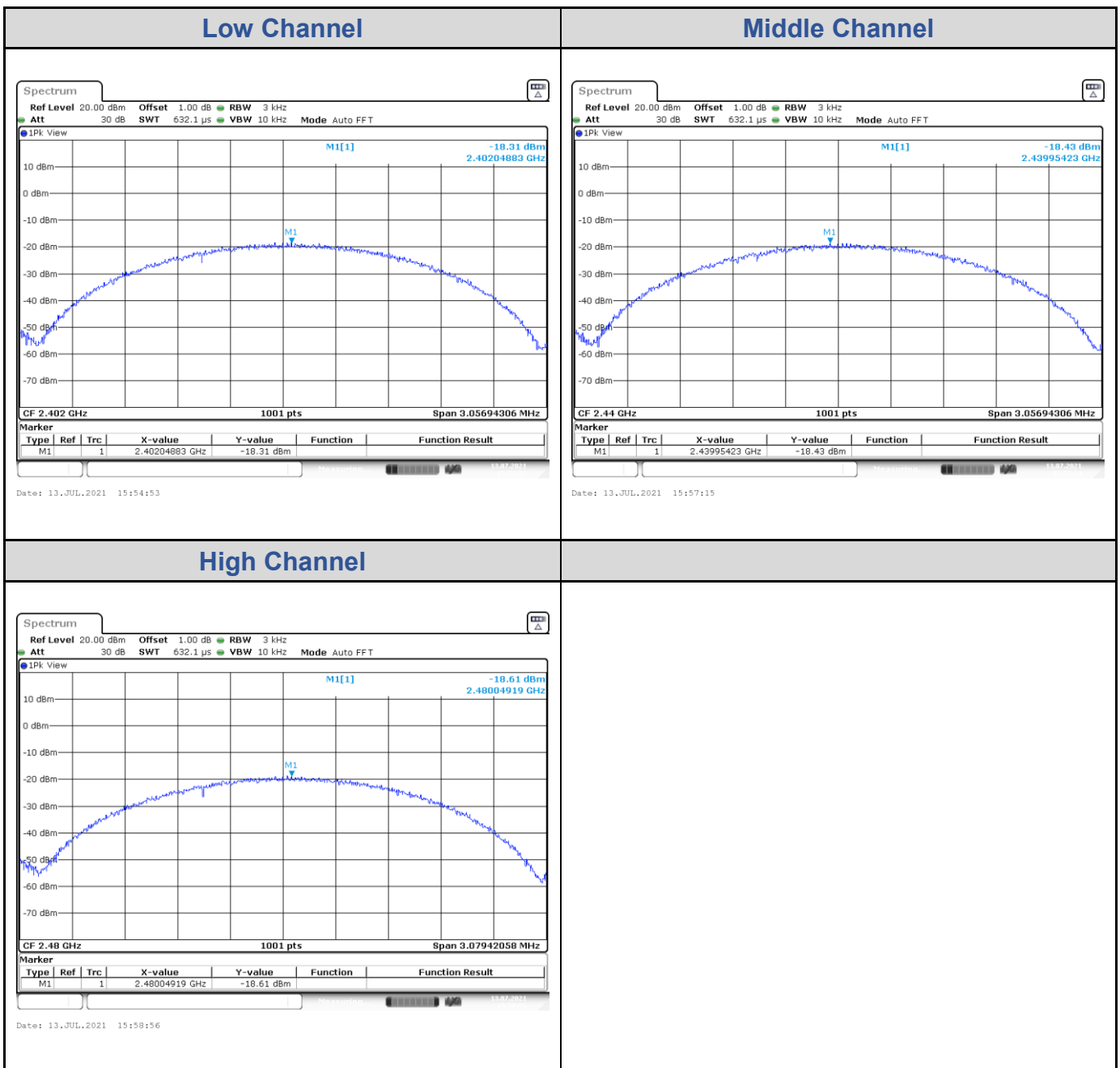

Test Result of Conducted Spurious Emissions, Tx Mode  
1Mbps

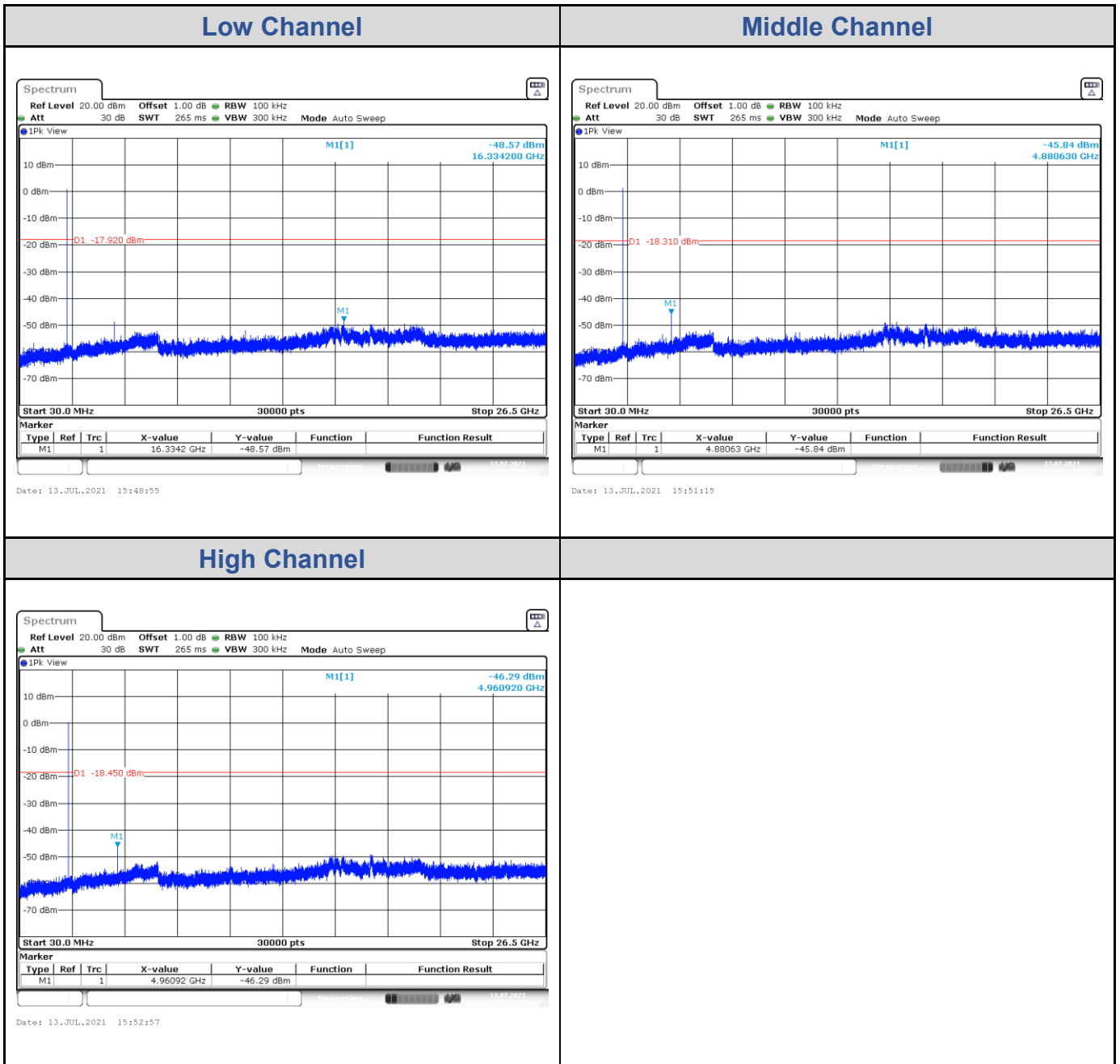

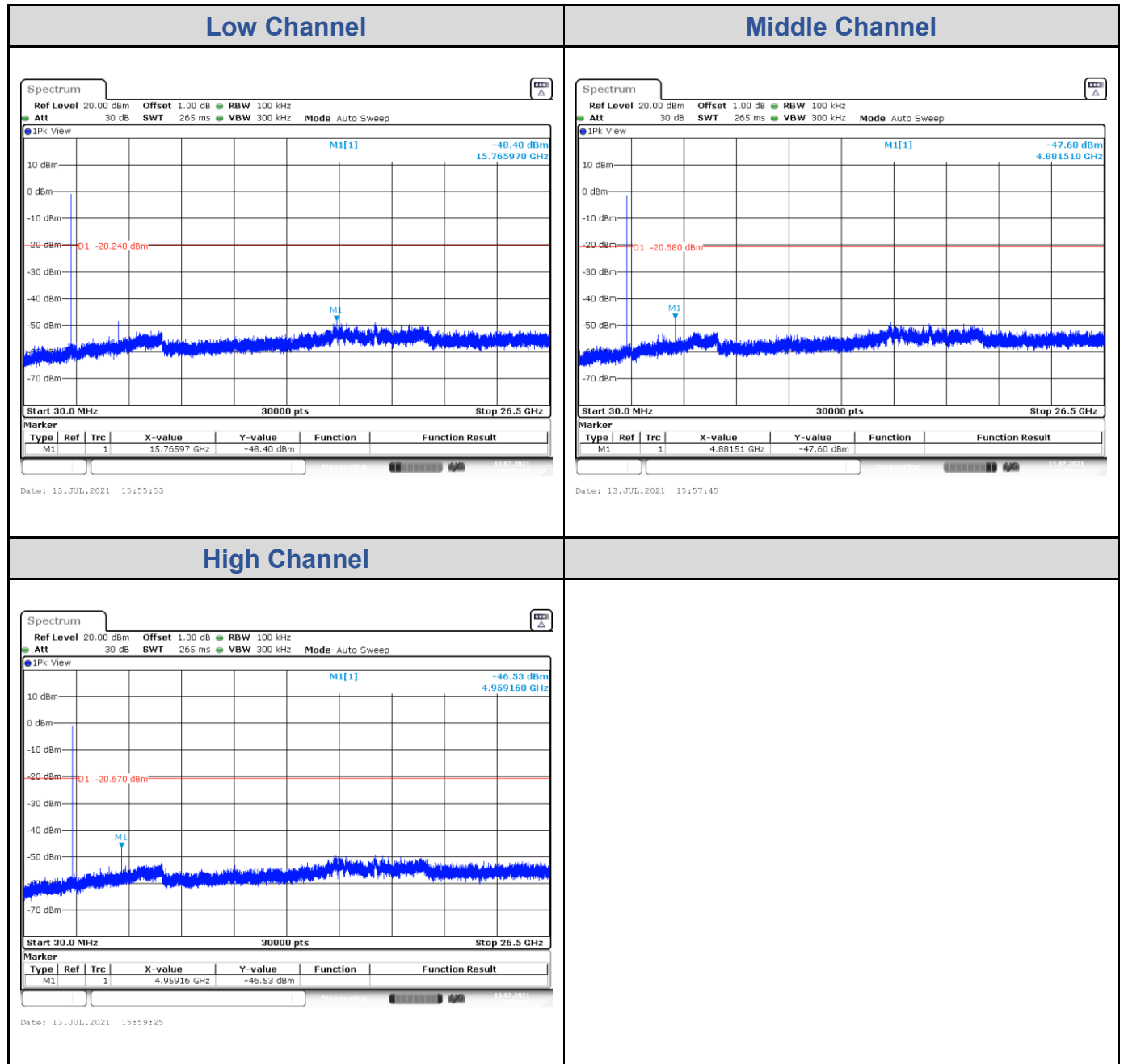
**2Mbps**

## Test Result of Conducted Band Edge, Tx Mode

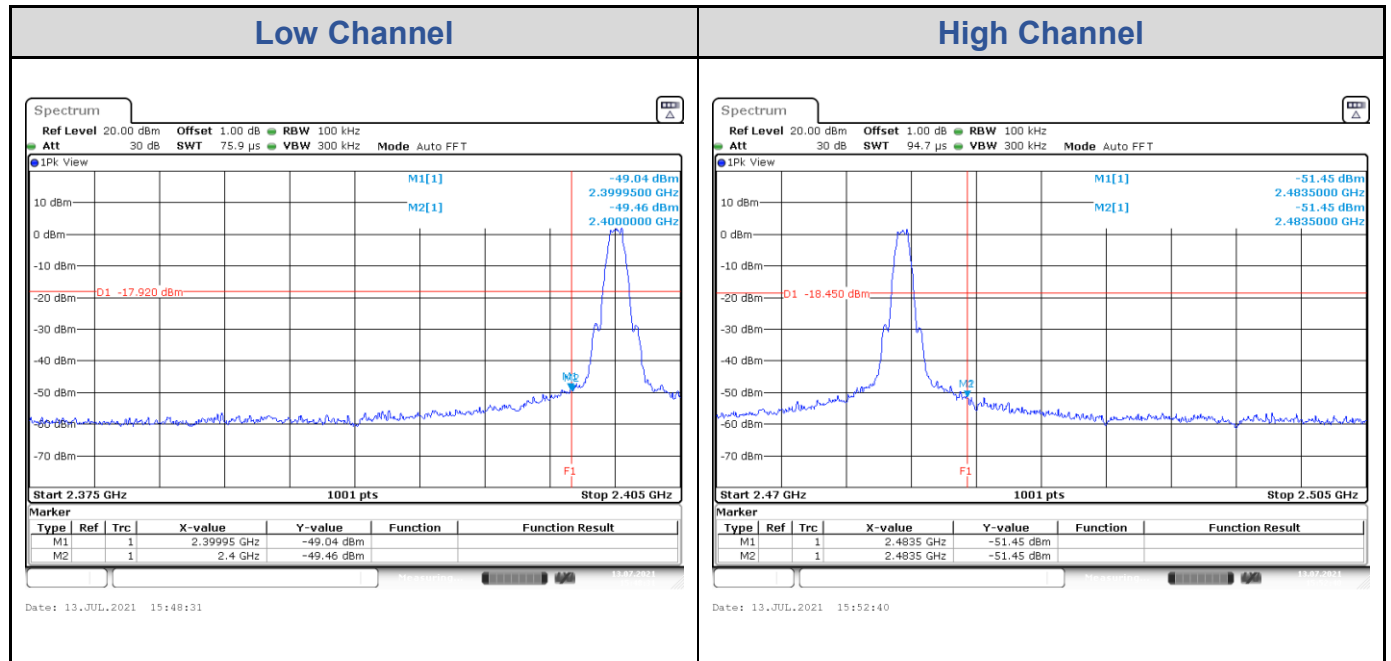
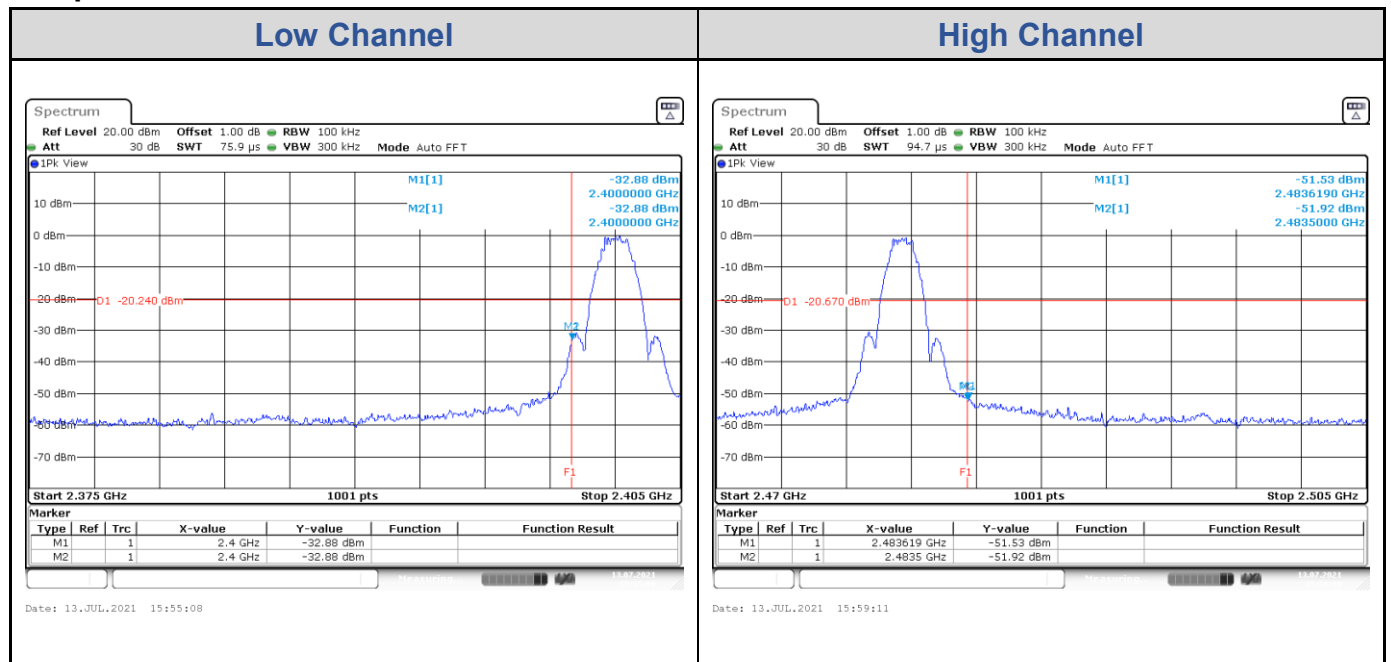
**1Mbps**

**2Mbps**

# Appendix B: Test Results of Radiated Emissions & Mains Conducted Emission Test

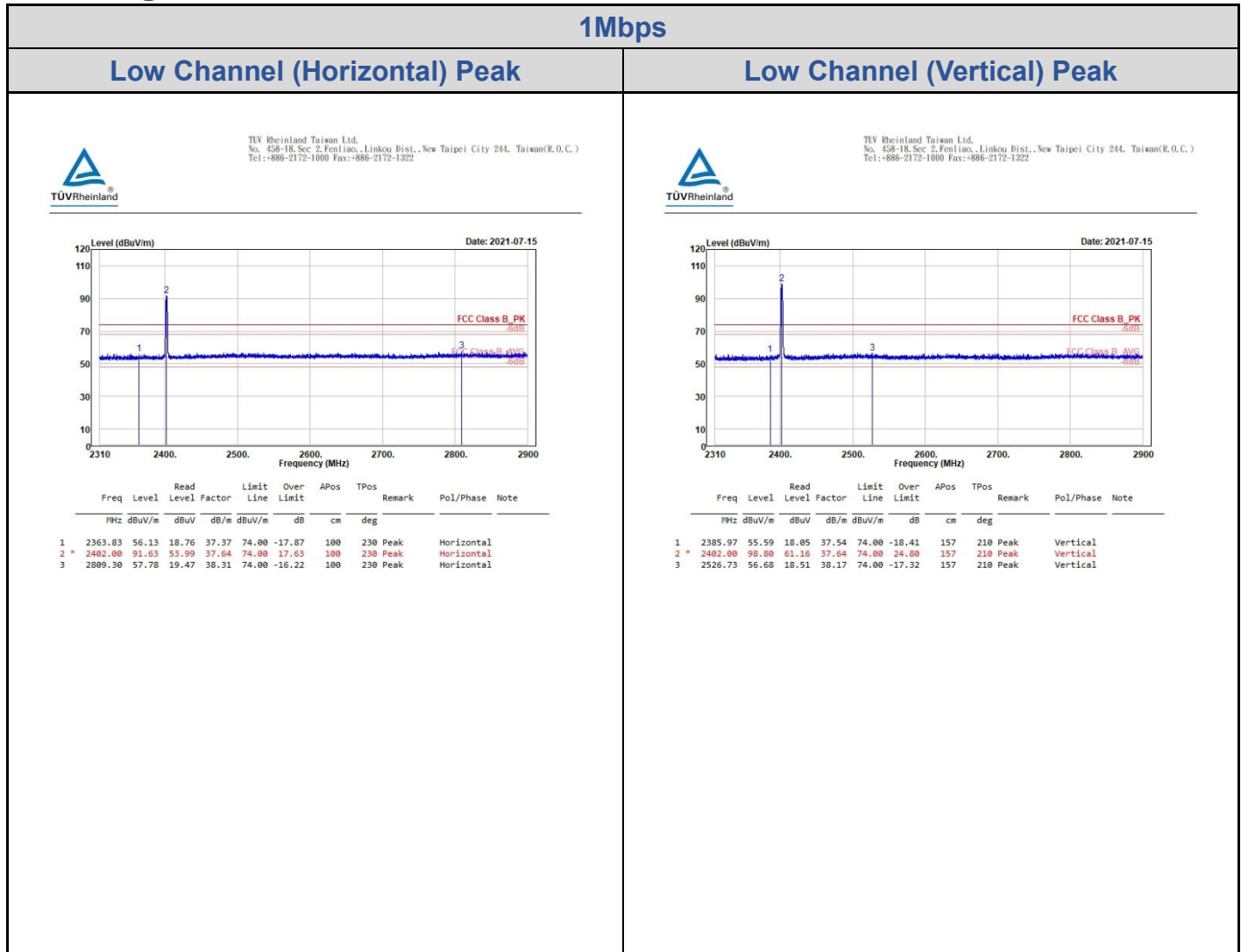
## Band Edges, 2.31GHz ~ 2.9GHz



1Mbps

Low Channel (Horizontal) Average

Low Channel (Vertical) Average



TUV Rheinland Taiwan Ltd.  
No. 458-18, Sec. 2, Fenhiao, Linkou Dist., New Taipei City 244, Taiwan(R.O.C.)  
Tel: +886-2172-1000 Fax: +886-2172-1322

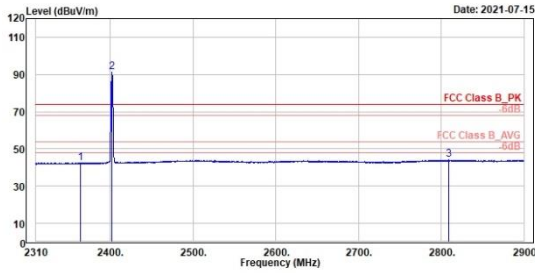

Freq	Level	Read	Level	Factor	Limit	Over	APos	TPos	Remark	Pol/Phase	Note
MHz	dBuV/m	dBuV	dB/m	dBuV/m	dB	cm	deg				
1	2363.83	42.64	5.27	37.37	54.00	-11.36	100	230	Average	Horizontal	
2 *	2482.00	91.06	53.42	37.64	54.00	37.06	100	230	Average	Horizontal	
3	2809.30	44.05	5.74	38.31	54.00	-9.95	100	230	Average	Horizontal	



TUV Rheinland Taiwan Ltd.  
No. 458-18, Sec. 2, Fenhiao, Linkou Dist., New Taipei City 244, Taiwan(R.O.C.)  
Tel: +886-2172-1000 Fax: +886-2172-1322

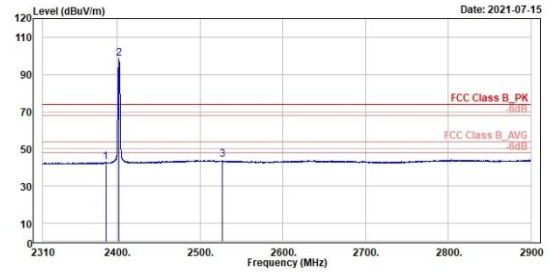

Freq	Level	Read	Level	Factor	Limit	Over	APos	TPos	Remark	Pol/Phase	Note
MHz	dBuV/m	dBuV	dB/m	dBuV/m	dB	cm	deg				
1	2385.97	42.77	5.23	37.54	54.00	-11.23	157	210	Average	Vertical	
2 *	2482.00	98.35	60.71	37.64	54.00	44.35	157	210	Average	Vertical	
3	2526.73	44.05	5.88	38.17	54.00	-9.95	157	210	Average	Vertical	

1Mbps

High Channel (Horizontal) Peak

High Channel (Vertical) Peak

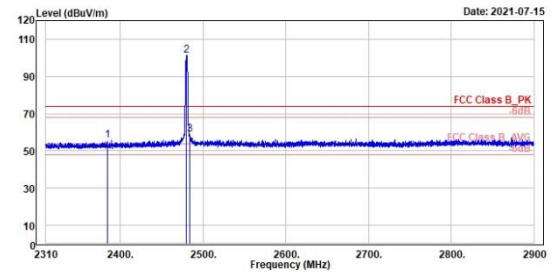
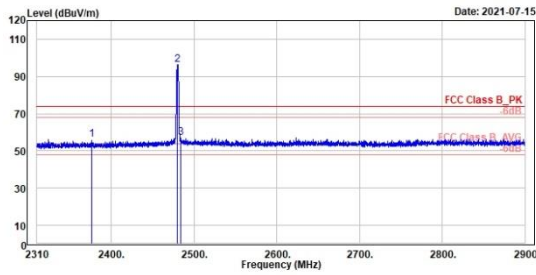

Peak	Freq	Level	Read	Level	Factor	Limit	Over	APos	TPos	Remark	Pol/Phase	Note
	MHz	dBuV/m	dBuV	dB/m	dBuV/m	dB	dB	cm	deg			
1	2375.73	56.03	18.50	37.45	74.00	-17.97	100	226	Peak	Horizontal		
2 *	2480.00	96.48	50.33	38.15	74.00	22.48	100	226	Peak	Horizontal		
3	2483.50	56.96	18.80	38.16	74.00	-17.04	100	226	Peak	Horizontal		

Peak	Freq	Level	Read	Level	Factor	Limit	Over	APos	TPos	Remark	Pol/Phase	Note
	MHz	dBuV/m	dBuV	dB/m	dBuV/m	dB	dB	cm	deg			
1	2384.44	55.72	18.20	37.52	74.00	-18.28	155	209	Peak	Vertical		
2 *	2480.00	101.43	63.28	38.15	74.00	27.43	155	209	Peak	Vertical		
3	2483.50	58.69	20.53	38.16	74.00	-15.31	155	209	Peak	Vertical		

1Mbps

High Channel (Horizontal) Average

High Channel (Vertical) Average



TUV Rheinland Taiwan Ltd.  
No. 458-18, Sec. 2, Fenhiao, Linkou Dist., New Taipei City 244, Taiwan(R.O.C.)  
Tel: +886-2172-1000 Fax: +886-2172-1322

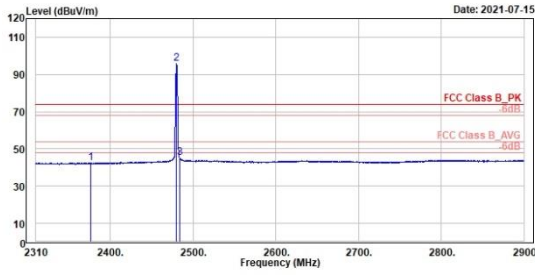

Freq	Level	Read	Level	Factor	Limit	Over	APos	TPos	Remark	Pol/Phase	Note
MHz	dBuV/m	dBuV	dB/m	dBuV/m	dB	dB	cm	deg			
1	2375.73	42.48	5.83	37.45	54.00	-11.52	100	226	Average	Horizontal	
2 *	2480.00	96.02	57.87	38.15	54.00	42.02	100	226	average	Horizontal	
3	2483.50	45.27	7.11	38.16	54.00	-8.73	100	226	Average	Horizontal	



TUV Rheinland Taiwan Ltd.  
No. 458-18, Sec. 2, Fenhiao, Linkou Dist., New Taipei City 244, Taiwan(R.O.C.)  
Tel: +886-2172-1000 Fax: +886-2172-1322

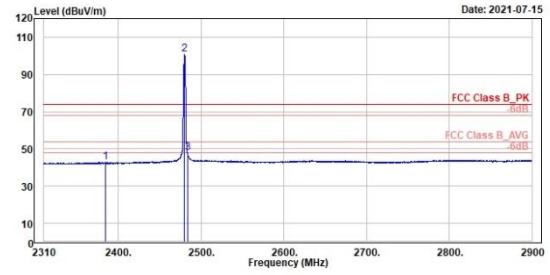

Freq	Level	Read	Level	Factor	Limit	Over	APos	TPos	Remark	Pol/Phase	Note
MHz	dBuV/m	dBuV	dB/m	dBuV/m	dB	dB	cm	deg			
1	2384.44	42.83	5.31	37.52	54.00	-11.17	155	209	Average	Vertical	
2 *	2480.00	101.00	62.85	38.15	54.00	47.00	155	209	Average	Vertical	
3	2483.50	47.77	9.61	38.16	54.00	-6.23	155	209	Average	Vertical	



2Mbps

Low Channel (Horizontal) Peak

Low Channel (Vertical) Peak

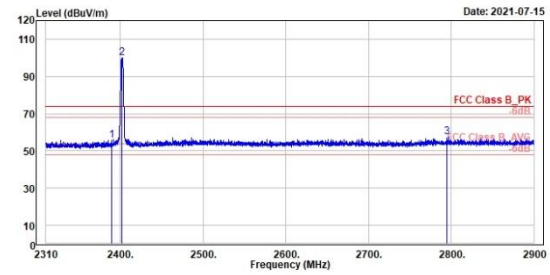
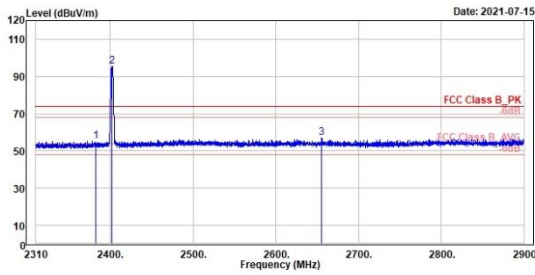

Freq	Level	Read	Limit	Over	APos	TPos	Remark	Pol/Phase	Note
MHz	dBuV/m	dBuV	dB/m	dBuV/m	dB	cm	deg		
1	2382.20	55.28	17.78	37.50	74.00	-18.72	142	208 Peak	Horizontal
2 *	2482.00	95.22	57.58	37.64	74.00	21.22	142	208 Peak	Horizontal
3	2655.47	56.91	18.87	38.04	74.00	-17.09	142	208 Peak	Horizontal

Freq	Level	Read	Limit	Over	APos	TPos	Remark	Pol/Phase	Note
MHz	dBuV/m	dBuV	dB/m	dBuV/m	dB	cm	deg		
1	2389.98	55.85	18.29	37.56	74.00	-18.15	158	211 Peak	Vertical
2 *	2482.00	99.98	62.26	37.64	74.00	25.98	158	211 Peak	Vertical
3	2794.82	57.36	19.87	38.29	74.00	-16.64	158	211 Peak	Vertical

2Mbps

Low Channel (Horizontal) Average

Low Channel (Vertical) Average



TUV Rheinland Taiwan Ltd.  
No. 458-18, Sec. 2, Fenhiao, Linkou Dist., New Taipei City 244, Taiwan(R.O.C.)  
Tel: +886-2172-1000 Fax: +886-2172-1322

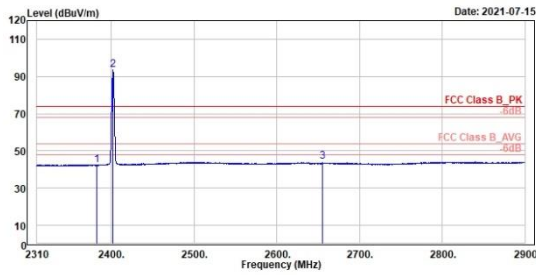

Freq	Level	Read	Level	Factor	Limit	Over	APos	TPos	Remark	Pol/Phase	Note
MHz	dBuV/m	dBuV	dB/m	dBuV/m	dB	dB	cm	deg			
1	2382.20	42.62	5.12	37.50	54.00	-11.38	142	208	Average	Horizontal	
2 *	2482.00	93.67	50.83	37.64	54.00	39.67	142	208	Average	Horizontal	
3	2655.47	44.08	6.04	38.04	54.00	-9.92	142	208	Average	Horizontal	



TUV Rheinland Taiwan Ltd.  
No. 458-18, Sec. 2, Fenhiao, Linkou Dist., New Taipei City 244, Taiwan(R.O.C.)  
Tel: +886-2172-1000 Fax: +886-2172-1322

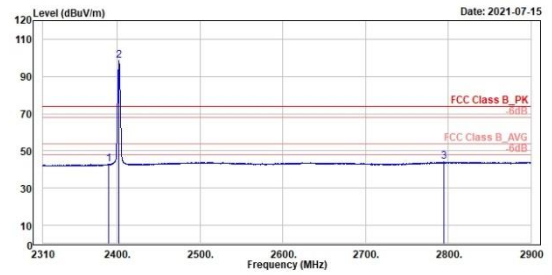

Freq	Level	Read	Level	Factor	Limit	Over	APos	TPos	Remark	Pol/Phase	Note
MHz	dBuV/m	dBuV	dB/m	dBuV/m	dB	dB	cm	deg			
1	2389.90	42.75	5.19	37.56	54.00	-11.25	158	211	Average	Vertical	
2 *	2482.00	98.33	68.69	37.64	54.00	44.33	158	211	Average	Vertical	
3	2794.82	44.05	5.76	38.29	54.00	-9.95	158	211	Average	Vertical	

2Mbps

High Channel (Horizontal) Peak

High Channel (Vertical) Peak

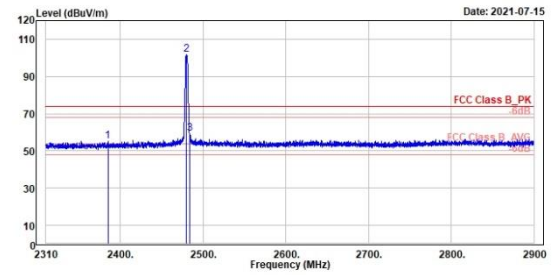
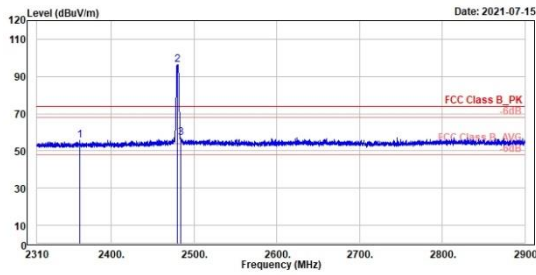

Peak	Freq (MHz)	Level (dBuV/m)	Read Level (dBuV)	Level Factor (dB/m)	Limit Line (dBuV/m)	Over Limit (dB)	APos (cm)	TPos (deg)	Remark	Pol/Phase	Note
1	2361.71	55.45	18.09	37.36	74.00	-18.55	106	227	Peak	Horizontal	
2 *	2480.00	96.42	58.27	38.15	74.00	22.42	106	227	Peak	Horizontal	
3	2483.50	57.21	19.05	38.16	74.00	-16.79	106	227	Peak	Horizontal	

Peak	Freq (MHz)	Level (dBuV/m)	Read Level (dBuV)	Level Factor (dB/m)	Limit Line (dBuV/m)	Over Limit (dB)	APos (cm)	TPos (deg)	Remark	Pol/Phase	Note
1	2384.91	55.34	17.82	37.52	74.00	-18.66	156	209	Peak	Vertical	
2 *	2480.00	101.53	63.38	38.15	74.00	27.53	156	209	Peak	Vertical	
3	2483.50	59.19	21.03	38.16	74.00	-14.81	156	209	Peak	Vertical	

2Mbps

High Channel (Horizontal) Average

High Channel (Vertical) Average

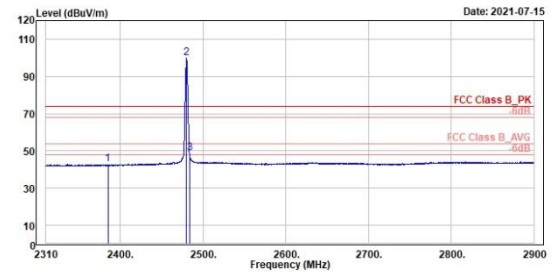
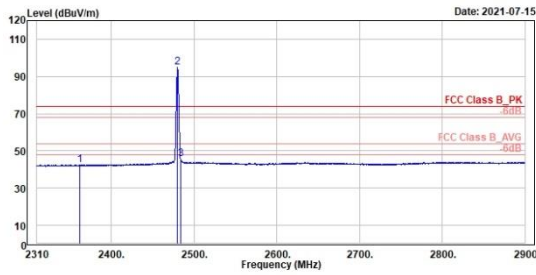

Freq	Level	Read Level	Factor	Limit Line	Over Limit	APos	TPos	Remark	Pol/Phase	Note
MHz	dBuV/m	dBuV	dB/m	dBuV/m	dB	cm	deg			
1	2361.71	42.54	5.18	37.36	54.00	-11.46	186	227 Average	Horizontal	
2 *	2480.00	94.82	56.67	38.15	54.00	40.82	186	227 Average	Horizontal	
3	2483.50	45.84	7.68	38.16	54.00	-8.16	186	227 Average	Horizontal	

Freq	Level	Read Level	Factor	Limit Line	Over Limit	APos	TPos	Remark	Pol/Phase	Note
MHz	dBuV/m	dBuV	dB/m	dBuV/m	dB	cm	deg			
1	2384.91	42.69	5.17	37.52	54.00	-11.31	156	209 Average	Vertical	
2 *	2480.00	99.98	61.83	38.15	54.00	45.98	156	209 Average	Vertical	
3 !	2483.50	48.85	10.69	38.16	54.00	-5.15	156	209 Average	Vertical	

Spurious Emissions, Tx Mode, 9kHz ~ 30MHz

1Mbps

Low Channel (Open) 9kHz~150kHz

Low Channel (Open) 150kHz~30MHz



TUV Rheinland Taiwan Ltd.  
No. 458-18, Sec. 2, Fenliao, Linkou Dist., New Taipei City 244, Taiwan(R.O.C.)  
Tel: +886-2172-1000 Fax: +886-2172-1322

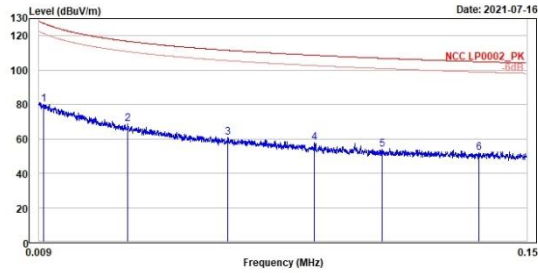

Freq	Level	Read	Limit	Over	Apos	TPos	Remark	Pol/Phase	Note
MHz	dBuV/m	dBuV	dB/m	dBuV/m	dB	cm	deg		
1	80.04	3.44	76.68	127.28	-47.24	100	212	QP	Open
2	68.85	1.23	67.62	116.81	-47.96	100	318	QP	Open
3	60.85	-1.20	62.05	111.52	-50.67	100	236	QP	Open
4	57.62	-1.14	58.76	108.65	-51.03	100	226	QP	Open
5	53.97	-2.94	56.91	106.92	-52.95	100	221	QP	Open
6	52.83	-3.68	55.71	104.92	-52.89	100	168	QP	Open



TUV Rheinland Taiwan Ltd.  
No. 458-18, Sec. 2, Fenliao, Linkou Dist., New Taipei City 244, Taiwan(R.O.C.)  
Tel: +886-2172-1000 Fax: +886-2172-1322

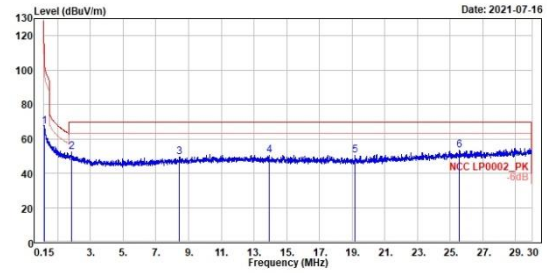

Freq	Level	Read	Limit	Over	Apos	TPos	Remark	Pol/Phase	Note
MHz	dBuV/m	dBuV	dB/m	dBuV/m	dB	cm	deg		
1	67.06	13.74	53.32	101.94	-34.88	100	206	QP	Open
2	52.19	12.83	39.36	69.50	-17.31	100	47	QP	Open
3	49.62	12.01	37.61	69.50	-19.88	100	255	QP	Open
4	50.53	12.63	37.90	69.50	-18.97	100	180	QP	Open
5	50.39	12.87	37.52	69.50	-19.11	100	83	QP	Open
6	53.25	13.20	40.05	69.50	-16.25	100	131	QP	Open

1Mbps

Low Channel (Close) 9kHz~150kHz

Low Channel (Close) 150kHz~30MHz



TUV Rheinland Taiwan Ltd.  
No. 458-18, Sec. 2, Fenliao, Linkou Dist., New Taipei City 244, Taiwan(R.O.C.)  
Tel: +886-2172-1000 Fax: +886-2172-1322

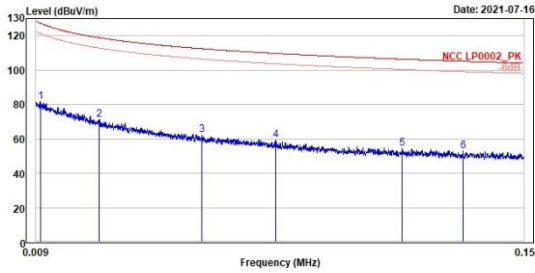

Freq	Level	Read	Limit	Over	Apos	TPos	Remark	Pol/Phase	Note
MHz	dBuV/m	dBuV	dB/m	dBuV/m	dB	cm	deg		
1	81.79	5.16	76.63	127.35	-45.56	100	280 QP	Close	
2	71.16	1.37	69.79	118.84	-47.68	100	265 QP	Close	
3	62.04	-0.89	62.93	112.48	-50.44	100	105 QP	Close	
4	59.12	-1.02	60.14	109.73	-50.61	100	109 QP	Close	
5	54.30	-2.32	56.62	106.39	-52.09	100	236 QP	Close	
6	52.87	-3.00	55.87	105.16	-52.29	100	8 QP	Close	



TUV Rheinland Taiwan Ltd.  
No. 458-18, Sec. 2, Fenliao, Linkou Dist., New Taipei City 244, Taiwan(R.O.C.)  
Tel: +886-2172-1000 Fax: +886-2172-1322

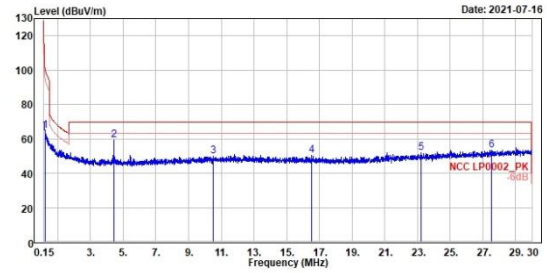

Freq	Level	Read	Limit	Over	Apos	TPos	Remark	Pol/Phase	Note
MHz	dBuV/m	dBuV	dB/m	dBuV/m	dB	cm	deg		
1	64.56	12.26	52.30	100.92	-36.36	100	238 QP	Close	
2	4.44	59.36	22.85	36.51	69.50	-10.14	100	199 QP	Close
3	10.50	49.96	11.82	38.14	69.50	-19.54	100	231 QP	Close
4	16.51	50.25	12.54	37.71	69.50	-19.25	100	27 QP	Close
5	23.21	51.92	12.97	38.95	69.50	-17.58	100	111 QP	Close
6	27.55	53.26	12.28	40.98	69.50	-16.24	100	313 QP	Close

**Spurious Emissions, Tx Mode, 30MHz ~ 1GHz**
**1Mbps**
**Low Channel (Horizontal)**
**Low Channel (Vertical)**

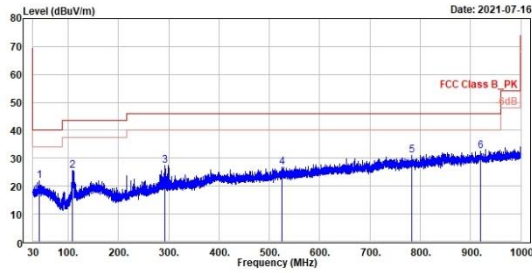
 TÜV Rheinland Taiwan Ltd.  
 No. 458-18, Sec. 2, Fenhiao, Linkou Dist., New Taipei City 244, Taiwan(R.O.C.)  
 Tel: +886-2172-1000 Fax: +886-2172-1322

Freq	Level	Read	Limit	Over	Apos	TPos	Remark	Pol/Phase	Note
MHz	dBuV/m	dBuV	dB/m	dBuV/m	dB	cm	deg		
1	41.93	22.03	29.76	-7.73	40.00	-17.97	100	15 QP	Horizontal
2	189.06	25.54	36.43	-10.89	43.50	-17.96	200	233 QP	Horizontal
3	293.16	27.29	33.91	-6.62	46.00	-18.71	100	308 QP	Horizontal
4	524.41	26.85	29.37	-2.52	46.00	-19.15	300	278 QP	Horizontal
5	783.59	30.88	29.09	1.79	46.00	-15.12	100	9 QP	Horizontal
6	919.39	32.62	28.77	3.85	46.00	-13.30	400	134 QP	Horizontal

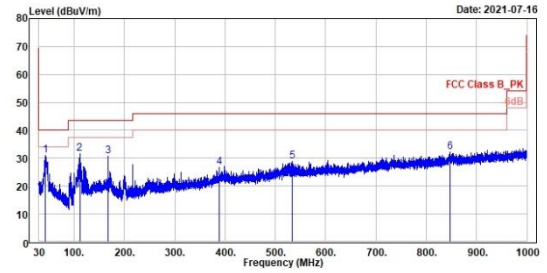
 TÜV Rheinland Taiwan Ltd.  
 No. 458-18, Sec. 2, Fenhiao, Linkou Dist., New Taipei City 244, Taiwan(R.O.C.)  
 Tel: +886-2172-1000 Fax: +886-2172-1322

Freq	Level	Read	Limit	Over	Apos	TPos	Remark	Pol/Phase	Note
MHz	dBuV/m	dBuV	dB/m	dBuV/m	dB	cm	deg		
1	43.19	31.05	38.64	-7.59	40.00	-9.95	100	2 QP	Vertical
2	111.00	31.53	42.52	-10.99	43.50	-11.97	300	4 QP	Vertical
3	167.93	30.65	38.18	-7.33	43.50	-12.65	100	184 QP	Vertical
4	388.80	26.64	30.96	-4.32	46.00	-19.36	200	332 QP	Vertical
5	534.11	28.86	31.37	-2.51	46.00	-17.14	100	326 QP	Vertical
6	847.32	32.29	29.73	2.56	46.00	-13.71	400	230 QP	Vertical

Spurious Emissions, Tx Mode, 1GHz ~ 26.5GHz

1Mbps

Low Channel (Horizontal)

Low Channel (Vertical)



TUV Rheinland Taiwan Ltd.  
No. 458-18, Sec. 2, Fenhiao, Linkou Dist., New Taipei City 244, Taiwan(R.O.C.)  
Tel: +886-2172-1000 Fax: +886-2172-1322

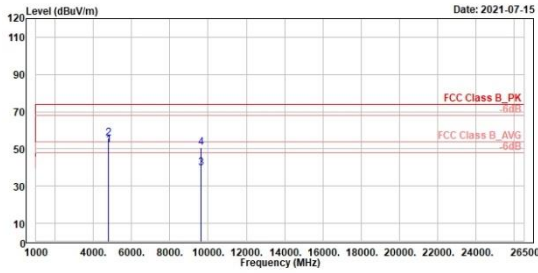

1	2	3	4	5	6	7	8	9	10	11	12	13	14	15	16	17	18	19	20
1	Level	Read	Level	Factor	Limit	Over	Apos	TPos	Remark	Pol/Phase	Note								
1	dBuV/m	MHz	dBuV	dB/m	dBuV/m	dB	cm	deg											
1	51.92	4984.00	61.70	-9.78	54.00	-2.08	349	356	Average	Horizontal									
2	55.60	4984.00	65.38	-9.78	74.00	-18.40	349	356	Peak	Horizontal									
3	39.67	9608.00	44.57	-4.90	71.06	-31.39	100	300	Average	Horizontal									
4	50.81	9608.00	55.71	-4.90	71.63	-20.82	100	300	Peak	Horizontal									



TUV Rheinland Taiwan Ltd.  
No. 458-18, Sec. 2, Fenhiao, Linkou Dist., New Taipei City 244, Taiwan(R.O.C.)  
Tel: +886-2172-1000 Fax: +886-2172-1322

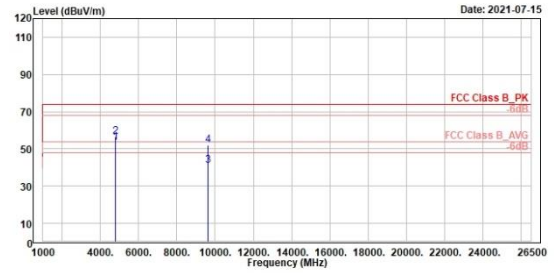

1	2	3	4	5	6	7	8	9	10	11	12	13	14	15	16	17	18	19	20
1	Level	Read	Level	Factor	Limit	Over	Apos	TPos	Remark	Pol/Phase	Note								
1	dBuV/m	MHz	dBuV	dB/m	dBuV/m	dB	cm	deg											
1	53.17	4984.00	62.95	-9.78	54.00	-0.83	182	238	Average	Vertical									
2	56.63	4984.00	66.41	-9.78	74.00	-17.37	182	238	Peak	Vertical									
3	41.18	9608.61	46.08	-4.90	78.35	-37.17	300	261	Average	Vertical									
4	52.16	9608.61	57.06	-4.90	78.00	-26.64	300	261	Peak	Vertical									



1Mbps

Middle Channel (Horizontal)

Middle Channel (Vertical)



TUV Rheinland Taiwan Ltd.  
No. 458-18, Sec. 2, Fenhiao, Linkou Dist., New Taipei City 244, Taiwan(R.O.C.)  
Tel: +886-2172-1000 Fax: +886-2172-1322

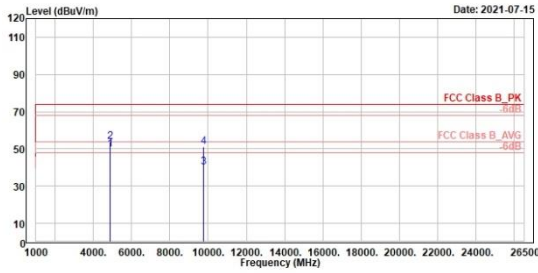

1	2	3	4	5	6	7	8	9	10	11	12	13	14	15	16	17	18	19	20
1	2	3	4	5	6	7	8	9	10	11	12	13	14	15	16	17	18	19	20
MHz	dBuV/m	dBuV	dB/m	dBuV/m	dB	cm	deg												
4888.00	49.57	59.24	-9.67	54.00	-4.43	357	343	Average	Horizontal										
4888.00	54.05	63.72	-9.67	74.00	-19.95	357	343	Peak	Horizontal										
9768.00	40.23	44.83	-4.60	73.69	-33.46	100	302	Average	Horizontal										
9768.00	51.04	55.64	-4.60	74.34	-23.30	100	302	Peak	Horizontal										



TUV Rheinland Taiwan Ltd.  
No. 458-18, Sec. 2, Fenhiao, Linkou Dist., New Taipei City 244, Taiwan(R.O.C.)  
Tel: +886-2172-1000 Fax: +886-2172-1322

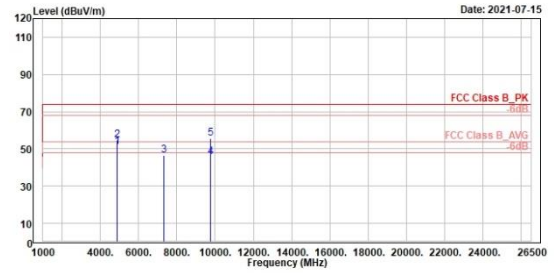

1	2	3	4	5	6	7	8	9	10	11	12	13	14	15	16	17	18	19	20
1	2	3	4	5	6	7	8	9	10	11	12	13	14	15	16	17	18	19	20
MHz	dBuV/m	dBuV	dB/m	dBuV/m	dB	cm	deg												
4888.00	51.05	60.72	-9.67	54.00	-2.95	100	245	Average	Vertical										
4888.00	54.91	64.58	-9.67	74.00	-19.09	100	245	Peak	Vertical										
7328.00	46.72	53.99	-7.27	74.00	-27.28	100	273	Peak	Vertical										
9768.00	45.63	50.23	-4.60	81.09	-35.46	400	252	Average	Vertical										
9768.00	55.88	60.48	-4.60	81.57	-25.69	400	252	Peak	Vertical										

1Mbps

High Channel (Horizontal)

High Channel (Vertical)



TUV Rheinland Taiwan Ltd.  
No. 458-18, Sec. 2, Fenhiao, Linkou Dist., New Taipei City 244, Taiwan(R.O.C.)  
Tel: +886-2172-1000 Fax: +886-2172-1322

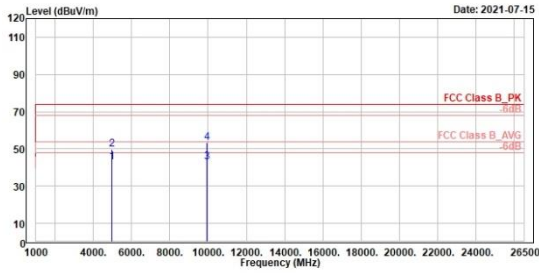

1	2	3	4
Level	Read Level	Factor	Limit
dBuV/m	dBuV	dB/m	dBuV/m
49.76	42.97	-9.46	54.00
42.82	42.82	-4.35	76.02
53.24	53.24	-4.35	76.48



TUV Rheinland Taiwan Ltd.  
No. 458-18, Sec. 2, Fenhiao, Linkou Dist., New Taipei City 244, Taiwan(R.O.C.)  
Tel: +886-2172-1000 Fax: +886-2172-1322

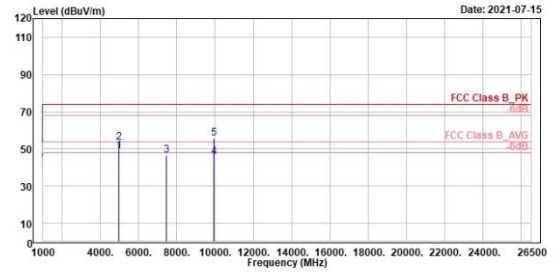

1	2	3	4	5
Level	Read Level	Factor	Limit	Over Limit
dBuV/m	dBuV	dB/m	dBuV/m	dB
50.27	48.81	-9.46	54.00	-5.19
62.85	49.68	-9.46	74.00	-20.61
53.80	46.55	-7.25	74.00	-27.45
35.36	49.28	-4.35	81.00	-35.36
25.58	55.85	-4.35	81.43	-25.58

**2Mbps**

**Low Channel (Horizontal)**

**Low Channel (Vertical)**



TÜV Rheinland Taiwan Ltd.  
No. 458-18, Sec. 2, Fenhiao, Linkou Dist., New Taipei City 244, Taiwan(R.O.C.)  
Tel: +886-2172-1000 Fax: +886-2172-1322

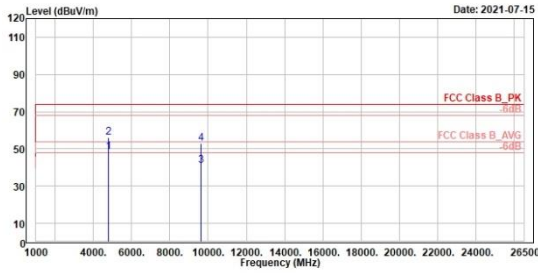

1	2	3	4	5	6	7	8	9	10	11	12	13	14	15	16	17	18	19	20	
1	Level	Read	Level	Factor	Limit	Over	Apos	TPos	Remark	Pol/Phase	Note									
1	MHz	dBuV/m	dBuV	dB/m	dBuV/m	dB	cm	deg												
1	4984.00	48.30	58.00	-9.78	54.00	-5.70	349	344	Average	Horizontal										
2	4984.00	56.17	65.95	-9.78	74.00	-17.83	349	344	Peak	Horizontal										
3	9608.00	40.92	45.82	-4.90	73.67	-32.75	100	301	Average	Horizontal										
4	9608.00	52.80	57.70	-4.90	75.22	-22.42	100	301	Peak	Horizontal										



TÜV Rheinland Taiwan Ltd.  
No. 458-18, Sec. 2, Fenhiao, Linkou Dist., New Taipei City 244, Taiwan(R.O.C.)  
Tel: +886-2172-1000 Fax: +886-2172-1322

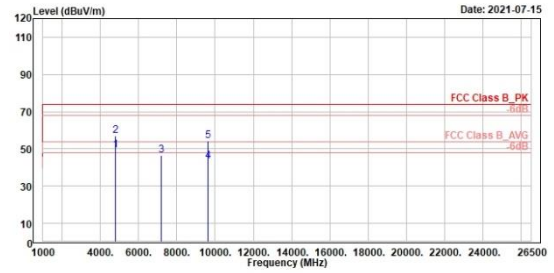

1	2	3	4	5	6	7	8	9	10	11	12	13	14	15	16	17	18	19	20	
1	Level	Read	Level	Factor	Limit	Over	Apos	TPos	Remark	Pol/Phase	Note									
1	MHz	dBuV/m	dBuV	dB/m	dBuV/m	dB	cm	deg												
1	4984.00	49.47	59.25	-9.78	54.00	-4.53	182	239	Average	Vertical										
2	4984.00	57.10	66.88	-9.78	74.00	-16.90	182	239	Peak	Vertical										
3	7206.00	46.75	53.99	-7.24	79.90	-33.15	300	334	Peak	Vertical										
4	9608.00	43.29	48.19	-4.90	78.33	-35.04	300	264	Average	Vertical										
5	9608.00	54.50	59.40	-4.90	79.90	-25.40	300	264	Peak	Vertical										

2Mbps

Middle Channel (Horizontal)

Middle Channel (Vertical)



TUV Rheinland Taiwan Ltd.  
No. 458-18, Sec. 2, Fenhiao, Linkou Dist., New Taipei City 244, Taiwan(R.O.C.)  
Tel: +886-2172-1000 Fax: +886-2172-1322

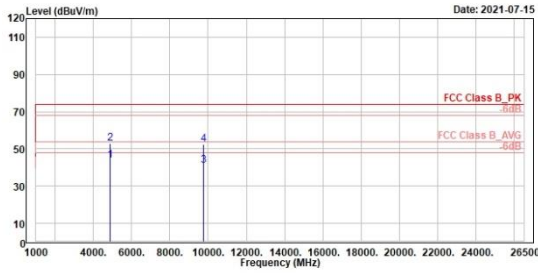

Line	Freq	Level	Read Level	Factor	Limit Line	Over Limit	APos	TPos	Remark	Pol/Phase	Note
	MHz	dBuV/m	dBuV	dB/m	dBuV/m	dB	cm	deg			
1	4880.00	43.97	53.64	-9.67	54.00	-10.03	400	337	Average	Horizontal	
2	4880.00	52.97	62.64	-9.67	74.00	-21.03	400	337	Peak	Horizontal	
3	9760.00	40.85	45.45	-4.60	74.51	-33.66	200	207	Average	Horizontal	
4	9760.00	52.68	57.28	-4.60	76.15	-23.47	200	207	Peak	Horizontal	



TUV Rheinland Taiwan Ltd.  
No. 458-18, Sec. 2, Fenhiao, Linkou Dist., New Taipei City 244, Taiwan(R.O.C.)  
Tel: +886-2172-1000 Fax: +886-2172-1322

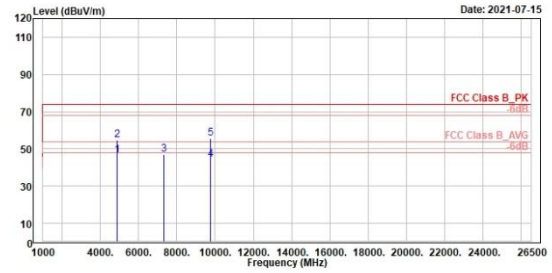

Line	Freq	Level	Read Level	Factor	Limit Line	Over Limit	APos	TPos	Remark	Pol/Phase	Note
	MHz	dBuV/m	dBuV	dB/m	dBuV/m	dB	cm	deg			
1	4880.00	46.35	56.02	-9.67	54.00	-7.65	100	246	Average	Vertical	
2	4880.00	54.73	64.40	-9.67	74.00	-19.27	100	246	Peak	Vertical	
3	7320.00	47.19	54.46	-7.27	74.00	-26.81	100	277	Peak	Vertical	
4	9760.00	44.31	48.91	-4.60	79.61	-35.30	400	252	Average	Vertical	
5	9760.00	55.55	60.15	-4.60	81.22	-25.67	400	252	Peak	Vertical	

2Mbps

High Channel (Horizontal)

High Channel (Vertical)



TUV Rheinland Taiwan Ltd.  
No. 458-18, Sec. 2, Fenhiao, Linkou Dist., New Taipei City 244, Taiwan(R.O.C.)  
Tel: +886-2172-1000 Fax: +886-2172-1322



TUV Rheinland Taiwan Ltd.  
No. 458-18, Sec. 2, Fenhiao, Linkou Dist., New Taipei City 244, Taiwan(R.O.C.)  
Tel: +886-2172-1000 Fax: +886-2172-1322

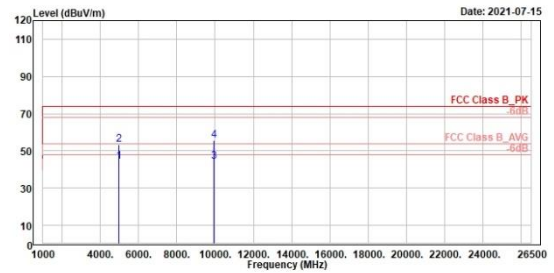
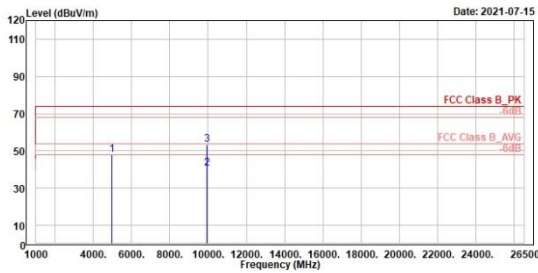

1	2	3								
198	318	318								
Peak	Average	Peak								
Horizontal	Horizontal	Horizontal								
4968.00	47.88	57.34	-9.46	74.00	-26.12	490				
9928.00	40.76	45.11	-4.35	74.82	-34.06	390				
9928.00	53.32	57.67	-4.35	76.42	-23.10	300				

1	2	3	4							
245	245	288	288							
Average	Peak	Average	Peak							
Vertical	Vertical	Vertical	Vertical							
4968.00	44.43	53.89	-9.46	54.00	-9.57	180				
4968.00	53.31	62.77	-9.46	74.00	-20.69	180				
9928.00	44.35	48.70	-4.35	79.98	-35.63	366				
9928.00	55.68	60.03	-4.35	81.53	-25.85	366				

Mains Conducted Emission, 150kHz ~ 30MHz

Worst Band

(Line)

(Neutral)



TUV Rheinland Taiwan Ltd(New Taipei City Branch).  
No. 458-19, Sec. 2, Fenliao Rd., Linkou Dist., New Taipei City 244  
Tel:+886-2172-1000 Fax:+886-2172-1322



TUV Rheinland Taiwan Ltd(New Taipei City Branch).  
No. 458-19, Sec. 2, Fenliao Rd., Linkou Dist., New Taipei City 244  
Tel:+886-2172-1000 Fax:+886-2172-1322

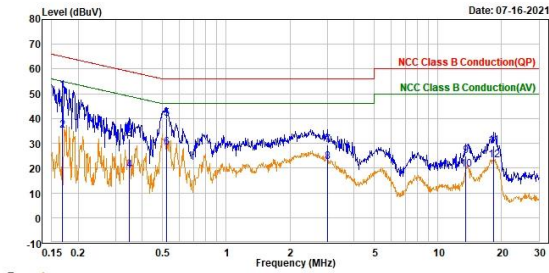

Trace: 1

	Read Freq	Level	Factor	Level	Limit Line	Over Limit	Remark	Pol/Phase	Note
	MHz	dBuV	dB	dBuV	dBuV	dB			
1	0.168	41.49	9.66	51.15	65.05	-13.90	QP	line1	
2	0.168	25.59	9.66	35.25	55.05	-19.80	Average	line1	
3	0.348	22.19	9.64	31.83	59.00	-27.17	QP	line1	
4	0.348	9.29	9.64	18.93	49.00	-30.07	Average	line1	
5	0.522	30.33	9.65	39.98	56.00	-16.02	QP	line1	
6	0.522	18.77	9.65	28.42	46.00	-17.58	Average	line1	
7	3.014	19.48	9.70	29.18	56.00	-26.82	QP	line1	
8	3.014	12.82	9.70	22.52	46.00	-23.48	Average	line1	
9	13.581	15.14	9.76	24.90	60.00	-35.10	QP	line1	
10	13.581	9.52	9.76	19.28	50.00	-30.72	Average	line1	
11	18.316	19.17	9.75	28.92	60.00	-31.08	QP	line1	
12	18.316	13.43	9.75	23.18	50.00	-26.82	Average	line1	

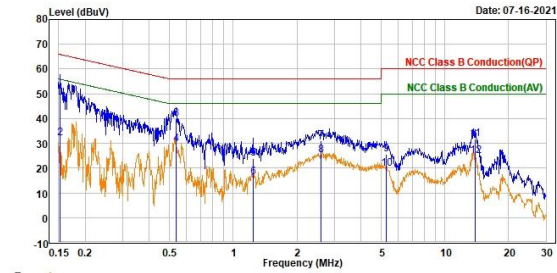

Trace: 1

	Read Freq	Level	Factor	Level	Limit Line	Over Limit	Remark	Pol/Phase	Note
	MHz	dBuV	dB	dBuV	dBuV	dB			
1	0.152	40.64	9.68	50.32	65.92	-15.60	QP	neutral	
2	0.152	22.48	9.68	32.16	55.92	-23.76	Average	neutral	
3	0.537	30.33	9.66	39.99	56.00	-16.01	QP	neutral	
4	0.537	19.96	9.66	29.62	46.00	-16.38	Average	neutral	
5	1.241	14.18	9.68	23.86	56.00	-32.14	QP	neutral	
6	1.241	6.83	9.68	16.51	46.00	-29.49	Average	neutral	
7	2.596	21.22	9.70	30.92	56.00	-25.08	QP	neutral	
8	2.596	15.46	9.70	25.16	46.00	-20.84	Average	neutral	
9	5.268	16.00	9.74	25.74	60.00	-34.26	QP	neutral	
10	5.268	9.97	9.74	19.71	50.00	-30.29	Average	neutral	
11	13.855	21.82	9.82	31.64	60.00	-28.36	QP	neutral	
12	13.855	15.21	9.82	25.03	50.00	-24.97	Average	neutral	