

R 1.0
4 PL

Scale: 1:1
Tolerance: ± 0.25
Units: mm

Material: 0.051 white polyester printed with black ink, then laminated to 0.025 clear polyester on top of print.

IM-155 adhesive applied to backside.

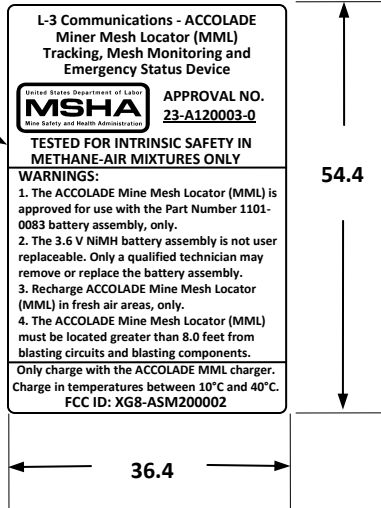

Total Assembly

Label with FCC information located in the 37mm x 65 mm indentation on rear of device

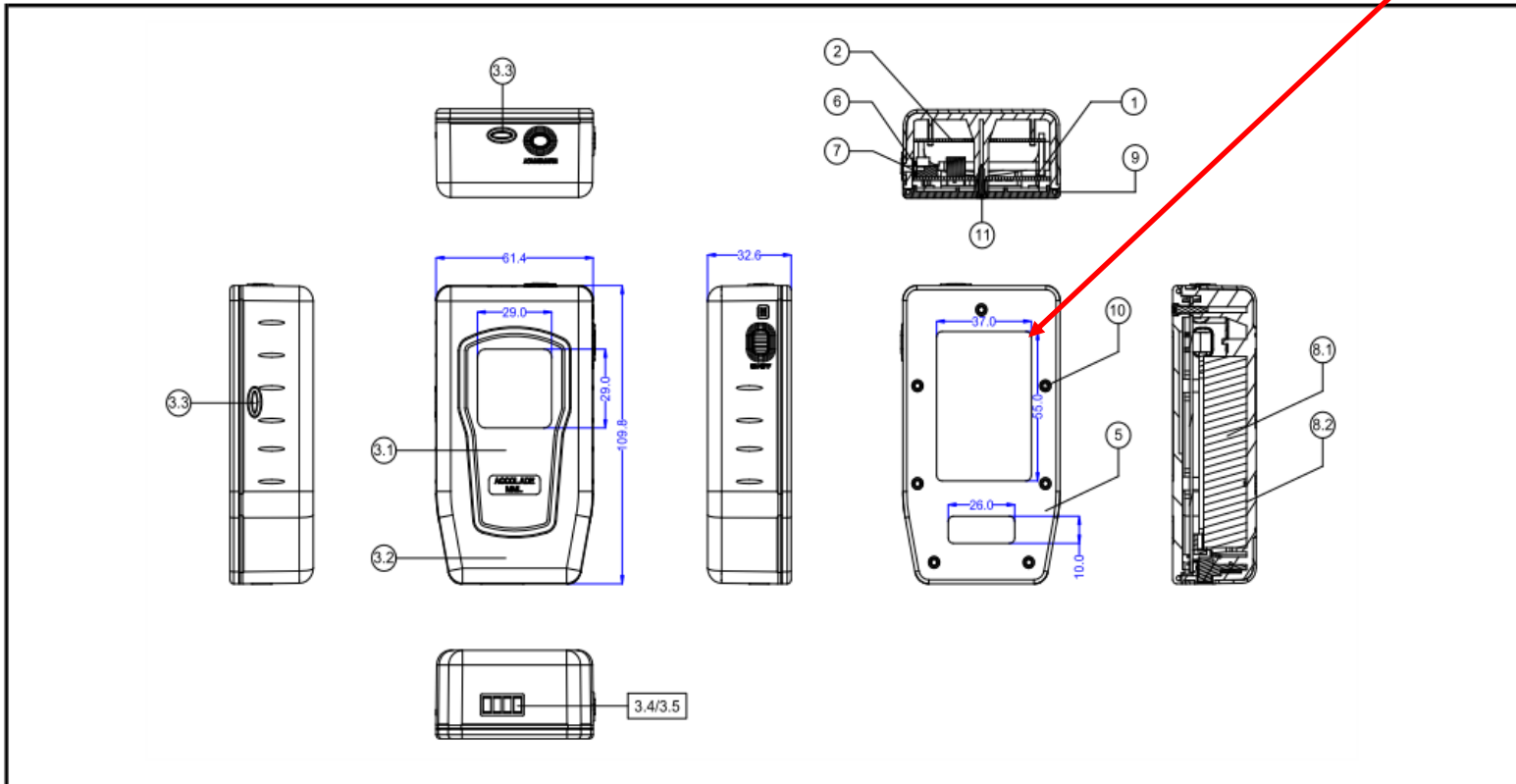

	MML Total Assembly Drawing	REV: 1.0	Page: 2 of 3
	DOCUMENT NUMBER: MML200002	P/N: 1101-0073	DATE: 20 DEC, 2010
DO NOT CHANGE WITOUT APPROVAL OF MSHA. ANY CHANGES IN THE INTRINCIALY SAFE CIRUCUITRY OR COMPONENTS MAY RESULT IN AN UNSAFE CONDITION.		UNLESS OTHERWISE SPECIFIED DIMENSIONS ARE IN MM TOLERANCES: .X=±0.2; .XX=±0.1 ANGLES = ±0.5	

