

The MMB Networks EM357 ZigBee Module is a drop-in ZigBee Smart Energy solution. Preloaded with MMB Research's RapidSE ZigBee Smart Energy application or RapidHA Home Automation application, it offers hardware vendors an easy way to integrate a fully-implemented, automated ZigBee Smart Energy or ZigBee Home Automation platform into their existing devices.

MMB Networks offers a variety of hardware and software development tools to facilitate integration. For more information, please visit <http://www.mmbnetworks.com>

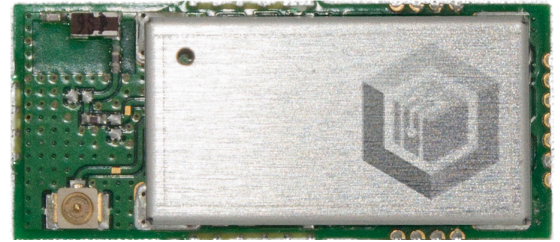

## Contents

1   <b>General Information</b> .....	2
2   <b>Memory</b> .....	2
3   <b>Module Pinout</b> .....	2
3.1   Debug and Programming Interface .....	3
4   <b>Electrical Specifications</b> .....	3
4.1   Absolute Maximum Ratings .....	3
4.2   Recommended Operating Conditions .....	3
4.3   DC Electrical Characteristics.....	4
5   <b>RF Specifications</b> .....	4
5.1   Receive Specifications .....	4
5.2   Transmit Specifications .....	5
6   <b>Functional Specifications</b> .....	5
6.1   Serial Ports.....	5
6.2   GPIO .....	6
6.3   Analog to Digital Converter (ADC) .....	7
7   <b>Mechanical Specifications</b> .....	8
7.1   Physical Dimensions .....	8
7.4   Labelling.....	9
8   <b>Soldering Temperature Time Profile for reflow soldering (Lead-free solder)</b> .....	9
9   <b>Regulatory Approvals</b> .....	10
9.1   FCC.....	10
9.2   Industry Canada (IC) .....	10
10   <b>Ordering Information</b> .....	11

## 1 | General Information

Note that some of the specifications refer to either EM357 or Module. Please note specifications cited as EM357 are taken from the EM357 datasheet (this should also be noted where referred to). Module means measurements taken with our production module.

## 2 | Memory

SKU	RAM (kB)	On-Chip Flash (kB)	Serial Flash (kB)
Z357A.1.0	12	192	512

## 3 | Module Pinout

Module Pad	Function	EM357 GPIO (EM357 Pin Number)
1	VCC (3.3 VDC)	CLK
2	nCTS/SPI Slave	PB3 (19)
3	nRTS/SPI Select	PB4 (20)
4	nReset, active low	(12)
5	PTI_EN	PA4 (26)
6	PTI_DATA	PA5 (27)
7	JTDO	PC2 (33)
8	JTCK	(32)
9	JTDI	PC3 (34)
10	JTMS	PC4 (35)
11	JRST	PCO (40)
12	RXD, SPI Slave In	PB2 (31)
13	Module Controlled Handshake Line	PA6 (29)
14	TXD, SPI Slave Out	PB1 (30)
15	GND	

## 3.1 | Debug and Programming Interface

In order to access the EM357 for programming and debug purposes, it is recommended that the designer incorporate Ember's 10-pin InSight Port connector. This will allow Ember's InSight Adapter (ISA3) to be used. Contact Ember for details regarding the InSight Port connector and ISA3.

The following table shows a pin mapping between Ember's 10-pin InSight Port connector and the module, and the graphic to the right displays the layout of the InSight Port connector.

Ember InSight Port Pin	Module Pin
1	10, 18 (VCC)
2	25 (PC2 / JTDO / SWO)
3	28 (PC0 / JRST)
4	26 (PC3 / JTDI)
5	1, 11, 19, 22, 32 (GND)
6	24 (JTCK)
7	27 (PC4 / JTMS / SWDIO)
8	17, 23 (nReset)
9	7 (PA4/PTI_EN)
10	6 (PA5/PTI_DATA)

VBRD	1	2	PC2 (JTDO/SWO)
PC0 (nJRST)	3	4	PC3 (JTDI)
GND	5	6	JCLK/SWCLK
PC4 (JTMS/SWDIO)	7	8	nRESET
PA4 (PTI_EN)	9	10	PA5 (PTI_DATA)

## 4 | Electrical Specifications

### 4.1 | Absolute Maximum Ratings

Parameter	Minimum	Maximum	Units
Supply Voltage (VCC)	0	3.6	V
Voltage on any GPIO ([PA[0:7], PB[0:7], PC[0:7]], JTCK, nReset)	-0.3	VCC + 0.3	V
Voltage on any GPIO pin (PA4, PA5, PB5, PB6, PB7, PC1) when used as an input to the general purpose ADC with the low voltage range selected	-0.3	2	V
Ambient Operating Temperature	-40	85	°C

### 4.2 | Recommended Operating Conditions

Parameter	Minimum	Typical	Maximum	Units
Supply Voltage (VCC)	2.7	3.3	3.6	V
Temperature Range	-40		85	°C

## 4.3 | DC Electrical Characteristics

Parameter	Test Condition	Minimum	Typical	Maximum	Units
Deep sleep current	At 25 °C, VCC = 3.3v, shutdown mode		0.65	TBD	μA
Idle current	At 25 °C, VCC = 3.3v, sleep mode		13		mA
RX current	At 25 °C, VCC = 3.3v		32		mA
TX current	At 25 °C, VCC = 3.3v, normal mode, 20 dBm		175	235	mA
Low Schmitt switching threshold	Schmitt input threshold going from high to low	0.42 x VCC		0.5 x VCC	V
High Schmitt switching threshold	Schmitt input threshold going from low to high	0.62 x VCC		0.8 x VCC	V
Input current for logic 0				-0.5	μA
Input current for logic 1				0.5	μA
Input pull-up resistor value		24	29	34	kΩ
Input pull-down resistor value		24	29	34	kΩ
Output voltage for logic 0		0		0.18 x VCC	V
Output voltage for logic 1		0.82 x VCC		VCC	V
Output source current (standard current pad)				4	mA
Output sink current (standard current pad)				4	mA
Output source current, high current pad: PA6, PA7, PB6, PB7, PC0				8	mA
Output sink current, high current pad: PA6, PA7, PB6, PB7, PC0				8	mA
Total output current (for I/O Pads)				40	mA

## 5 | RF Specifications

### 5.1 | Receive Specifications

#### Module Receive Characteristics

Parameter	Test Condition	Min	Typical	Max	Units
Receive sensitivity	1% PER as per IEEE 802.15.4	-107	-106	-100	dBm

### EM357 Receive Characteristics

This table lists the key parameters of the integrated IEEE 802.15.4-2003 receiver on the EM357. This information is taken from the Ember EM357 Datasheet. This document is available at:

<http://www.silabs.com/Support%20Documents/TechnicalDocs/EM35x.pdf>

**Note:** Receive measurements were collected with Ember's EM35x Ceramic Balun Reference Design (Version A0) at 2440MHz. The Typical number indicates one standard deviation above the mean, measured at room temperature (25°C). The Min and Max numbers were measured over process corners at room temperature.

Parameter	Test Condition	Min	Typical	Max	Units
Frequency range		2400		2500	MHz
Relative frequency error (2x40 ppm required by IEEE 802.15.4-2003)		-120		120	ppm
Relative timing error (2x40 ppm required by IEEE 802.15.4-2003)		-120		120	ppm
Linear RSSI range	As defined by IEEE 802.15.4-2003	40			dB
RSSI Range		-90		-40	dB

## 5.2 | Transmit Specifications

Parameter	Test Condition	Min	Typical	Max	Units
Output Power at highest power setting		20	21	21.5	dBm
Error vector magnitude as per IEEE 802.15.4			5	15	%
Carrier frequency error		-40		40	ppm
PSD Mask relative	3.5 MHz distance from carrier	-20			dB
PSD Mask absolute	3.5 MHz distance from carrier	-30			dBm

## 6 | Functional Specifications

### 6.1 | Serial Ports

Refer to the EM357 data sheet for functionality and associated GPIO pin outs.

Note: The module pin out table in section 2 of this document provides a cross reference between the MMB PA module pins and the EM357 GPIO.

#### 6.1.1 | SC1 Serial Controller (UART, SPI, TWI)

The SC1 module provides UART, SPI (master or slave), or TWI (master) serial communications.

##### Serial Controller Features

The SPI master controller has the following features: (*\*Note: the SPI master controller data is provided to show the hardware capability. RapidSE is configured as a SPI Slave, not Master*)

- Full duplex operation
- Programmable clock frequency (12 MHz max.)
- Programmable clock polarity and clock phase

- Selectable data shift direction (either LSB or MSB first)
- Receive and transmit FIFOs
- Receive and transmit DMA channels
- The following signals can be made available on the GPIO pins:
  - MOSI (serial data out)
  - MISO (serial data in)
  - MCLK (serial clock out)

The SPI slave controller has the following features:

- Full duplex operation
- Up to 4 Mbps data transfer rate
- Programmable clock polarity and clock phase
- Selectable data shift direction (either LSB or MSB first)
- Slave select input
- The following signals can be made available on the GPIO pins:
  - MOSI (serial data in)
  - MISO (serial data out)
  - SCLK (serial clock in)
  - nSSEL (slave select)

The TWI master controller has the following features:

- Uses only two bidirectional GPIO pins
- Programmable clock frequency (up to 400 kHz)
- Supports 7-bit and 10-bit addressing
- Compatible with Philips I<sup>2</sup>C-bus slave devices
- The following signals can be made available on the GPIO pins:
  - SDA (bidirectional serial data)
  - SCL (bidirectional serial clock)

The SC1 UART supports the following features:

- Baud rate (300 bps up to 921.6 kbps) (*\*Note: these values are provided to show the hardware capability. RapidSE does not provide the ability to modify the baud rate from the default value of 115.2 kbps. However, MMB can adjust it as necessary through a Non-Recurring Engineering engagement*)
- Data bits (7 or 8)
- Parity bits (none, odd, or even)
- Stop bits (1 or 2)
- False start bit and noise filtering
- Receive and transmit FIFOs
- Optional CTS/RTS flow control
- Receiver and transmit DMA channels
- GPIO signals:
  - TXD (serial data out)
  - RXD (serial data in)
  - nRTS (optional)
  - nCTS (optional)

## 6.2 | GPIO

The EM357 has multi-purpose GPIO pins that may be individually configured as:

- General purpose output
- General purpose open-drain output
- Alternate output controlled by a peripheral device
- Alternate open-drain output controlled by a peripheral device
- Analog

- General purpose input
- General purpose input with pull-up or pull-down resistor

### 6.3 | Analog to Digital Converter (ADC)

The ADC is a first-order sigma-delta converter with the following features:

- Resolution of up to 14 bits
- Sample times as fast as 5.33  $\mu$ s (188 kHz)
- Differential and single-ended conversions from six external and four internal sources
- One voltage range (differential): -VREF to +VREF
- Choice of internal or external VREF
- internal VREF may be output to PB0 or external VREF may be derived from PB0
- Digital offset and gain correction
- Dedicated DMA channel with one-shot and continuous operating modes

Parameter	Min	Typical	Max	Units
Conversion time	32		4096	$\mu$ s
VREF	1.17	1.2	1.23	V
VREF output current			1	mA
VREF load capacitance			10	nF
External VREF voltage range	1.1	1.2	1.3	V
External VREF input impedance	1			M Ohm
Minimum input voltage (input buffer disabled)	0			V
Minimum input voltage (input buffer enabled)	0.1			V
Maximum input voltage (input buffer disabled)			VREF	V
Maximum input voltage (input buffer enabled)			VCC – 0.1	V
Single-ended signal range (input buffer disabled)	0		VREF	V
Single-ended signal range (input buffer enabled)	0.1		VCC – 0.1	V
Differential signal range (input buffer disabled)	=-VREF		=+VREF	V
Differential signal range (input buffer enabled)	=- VCC + 0.1		+VCC – 0.1	V
Common mode range (input buffer disabled)	0		VREF	V
Common mode range (input buffer enabled)		VCC/2		V
Input referred ADC offset	-10		10	mV
Input impedance (1 MHz sample clock)	1			M Ohm
Input impedance (6 MHz sample clock)	0.5			M Ohm
Input impedance (Not Sampling)	10			M Ohm

## 7 | Mechanical Specifications

### 7.1 | Physical Dimensions

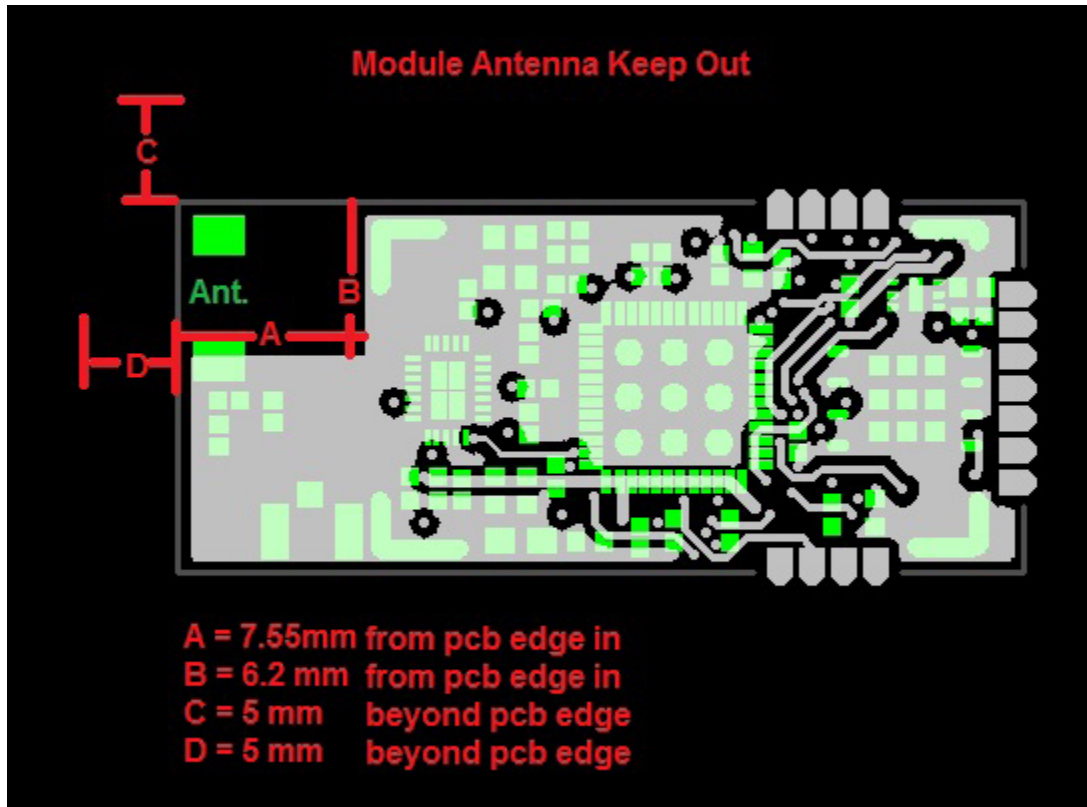

Symbol	Description	Distance
L	Length of the module	34.2 mm
W	Width of the module	15 mm
H	Height of the module	2.88 mm
A1	Pitch	1.27 mm
A2	Distance centre of pad to PCB edge	6 mm
A3	Distance center of pad to PCB edge	3.7 mm
A	Length of keep-out zone	7.55 mm
B	Width of keep-out zone	6.2 mm
C	Keep-out zone from corner of PCB	5 mm (minimum)
D	Keep-out zone from corner of PCB	5 mm (minimum)



## 7.4 | Labelling



## 8 | Soldering Temperature Time Profile for reflow soldering (Lead-free solder)

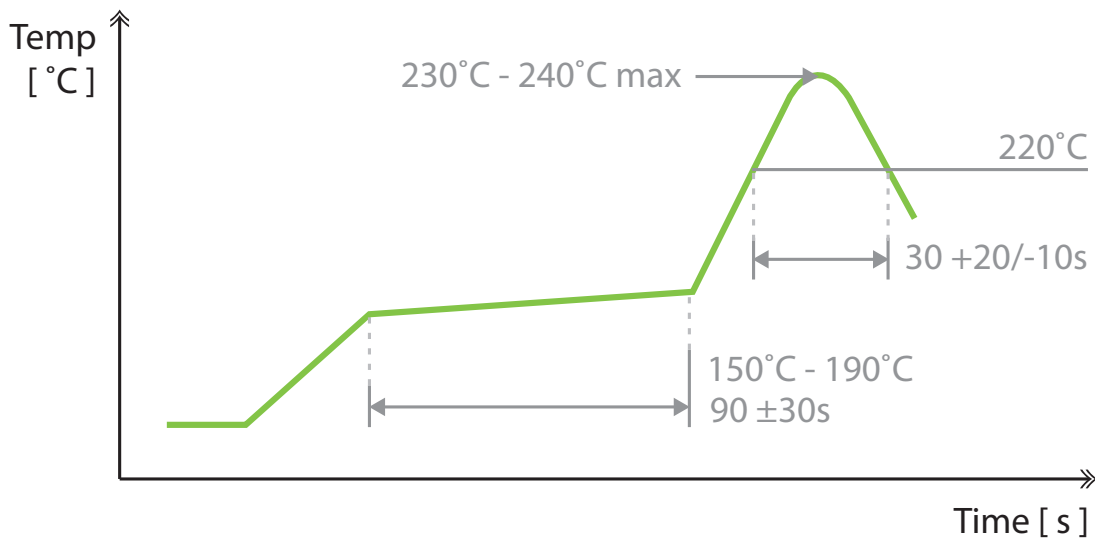

Maximum reflow cycles: 2

Opposite-side reflow is prohibited due to the module weight. You must not place the module on the bottom / underside of your PCB and re-flow.

## 9 | Regulatory Approvals

### 9.1 | FCC

#### 9.1.1 | FCC Notice

This device (Z357PA20-SMT, Z357PA21-SMT) complies with Part 15 of the FCC rules. Operation is subject to the following two conditions:

- (1) This device may not cause harmful interference, and
- (2) This device must accept any interference received, including interference that may cause undesired operation.

To comply with FCC RF Exposure requirements, users of this device must ensure that the module be installed and/or configured to operate with a separation distance of 20cm or more from all persons.

Usage of Channel 26 at full power will result in non-compliance to FCC standards. Manufacturer recommends avoiding use of channel 26 and if necessary only use with a reduced power setting. For further details please contact Manufacturer.

#### 9.1.2 | Modular Approval

This device (Z357PA20-SMT, Z357PA21-SMT) meets the requirements for modular transmitter approval as detailed in the FCC public notice DA 00-1407.

It should be noted that:

"While the applicant for a device into which an authorized module is installed is not required to obtain a new authorization for the module, this does not preclude the possibility that some other form of authorization or testing may be required for the device (e.g., a WLAN into which an authorized module is installed must still be authorized as a PC peripheral, subject to the appropriate equipment authorization)."

-- FCC Public Notice DA 00-1407

#### **Caution:**

Changes or modifications not expressly approved by the party responsible for compliance could void the user's authority to operate the equipment.

#### 9.1.3 | Labeling Requirements

The user of this device is responsible for meeting the FCC labeling requirements. A clearly visible label on the exterior enclosure of an incorporating device must list the MMB Research Inc. FCC ID "XFFZ357PA20" and the FCC Notice above (section 9.1.1).

The exterior label should use the wording "Contains" or "Contains Transmitter Module". For example:

***Contains FCC ID: XFFZ357PA20***

or

***Contains Transmitter Module FCC ID: XFFZ357PA20***

Any similar wording that expresses the same meaning may be used.

## 9.2 | Industry Canada (IC)

### 9.2.1 | IC Notice

This device complies with Industry Canada licence-exempt RSS standard(s).

Operation is subject to the following two conditions:

- (1) this device may not cause interference, and
- (2) this device must accept any interference, including interference that may cause undesired operation of the device.

Le présent appareil est conforme aux CNR d'Industrie Canada applicables aux appareils radio exempts de licence.

L'exploitation est autorisée aux deux conditions suivantes :

- (1) l'appareil ne doit pas produire de brouillage, et
- (2) l'utilisateur de l'appareil doit accepter tout brouillage radioélectrique subi, même si le brouillage est susceptible d'en compromettre le fonctionnement.

### 9.2.2 | Labeling Requirements

The host device shall be properly labelled to identify the modules within the host device. The Industry Canada certification label of a module shall be clearly visible at all times when installed in the host device, otherwise the host device must be labelled to display the Industry Canada certification number of the module, preceded by the words “Contains transmitter module”, or the word “Contains”, or similar wording expressing the same meaning, as follows:

**Contains transmitter module IC: 8365A-Z357PA20**

## 10 | Ordering Information

SKU	Interface Option	Software Option	Security Certificate
Z357PA21-SMT-P-TC	Surface Mount	Pre-Programmed	Test Certificate
Z357PA21-SMT-P-PC	Surface Mount	Pre-Programmed	Production Certificate
Z357PA21-SMT-N	Surface Mount	No Software	N/A

Copyright © 2013 MMB Research Inc. All rights reserved.

The information in this document is subject to change without notice. This document is believed to be accurate and reliable, but the statements contained herein are presented without expressed or implied warranty. MMB Networks is a division of MMB Research Inc.

RapidSE is a trademark of MMB Research Inc.

All other trademarks are the property of their respective holders.



25 Prince Arthur Ave. 416.636.3145  
Toronto, Ontario, Canada info@mmbresearch.com  
M5R1B2 www.mmbresearch.com