

Global EMC Inc. Labs EMC & RF Test Report

As per

RSS 210 Issue 6:2005

&

FCC Part 15 Subpart C:2006

Unlicensed Intentional Radiators

On the

RapidSE Zigbee Smart Energy Module

ZGB.MMB-PA-LNA.1.0 and ZGB.MMB.-PA.1.0



Ashwani Malhotra
Global EMC Inc.
180 Brodie Dr, Unit 2
Richmond Hill, ON L4B 3K8
Canada
Ph: (905) 883-3919

Testing produced for



See Appendix A for full customer & EUT details.



LAB REGISTRATION #6844A-1



FCC REGISTRATION
#612361





Client	MMB Research	
Product	RapidSE Zigbee Smart Energy Module ZGB.MMB-PA-LNA.1.0 and ZGB.MMB.-PA.1.0	
Standard(s)	RSS 210 Issue 6:2005 / FCC Part 15 Subpart C 15:2006	

Table of Contents

Table of Contents	2
Report Scope	3
Summary	4
Test Results Summary	5
Justifications, Descriptions, or Deviations.....	6
Applicable Standards, Specifications and Methods.....	7
Sample calculation(s).....	8
Document Revision Status.....	8
Definitions and Acronyms	9
Testing Facility	10
Calibrations and Accreditations.....	10
Testing Environmental Conditions and Dates	11
Detailed Test Results Section	12
Spurious Radiated Emissions.....	13
6dB Bandwidth of Digitally Modulated Systems	40
Maximum Peak Envelope Conducted Power	45
Antenna Spurious Conducted Emissions (- 20 dbc Requirement).....	50
Power Spectral Density.....	62
Maximum Permissible Exposure	67
Power Line Conducted Emissions	68
Appendix A – EUT Summary.....	74
Appendix B – EUT and Test Setup Photographs.....	75

Client	MMB Research	
Product	RapidSE Zigbee Smart Energy Module ZGB.MMB-PA-LNA.1.0 and ZGB.MMB.-PA.1.0	
Standard(s)	RSS 210 Issue 6:2005 / FCC Part 15 Subpart C 15:2006	

Report Scope

This report addresses the EMC verification testing and test results of the RapidSE Zigbee Smart Energy Module, ZGB.MMB-PA-LNA.1.0 and ZGB.MMB.-PA.1.0 module, herein referred to as EUT (Equipment Under Test) performed at Global EMC Labs.

The EUT was tested for compliance against the following standards:

RSS 210 Issue 6:2005 / FCC Part 15 Subpart C 15:2006

Test procedures, results, justifications, and engineering considerations, if any, follow later in this report.

The results contained in this report relate only to the item(s) tested.

This report does not imply product endorsement by A2LA or any other accreditation agency, any government, or Global EMC Inc.

Opinions/interpretations expressed in this report, if any, are outside the scope of Global EMC Inc accreditation. Any opinions expressed do not necessarily reflect the opinions of Global EMC Inc, unless otherwise stated.

Client	MMB Research	
Product	RapidSE Zigbee Smart Energy Module ZGB.MMB-PA-LNA.1.0 and ZGB.MMB.-PA.1.0	
Standard(s)	RSS 210 Issue 6:2005 / FCC Part 15 Subpart C 15:2006	

Summary

The results contained in this report relate only to the item(s) tested.

EUT FCC Certification #, FCC ID:	XFFMMBPA10
EUT Industry Canada Certification #, IC:	8365A-MMBPA10
EUT Passed all tests performed.	Yes (see test results summary)
Tests conducted by	Ashwani Malhotra

Client	MMB Research	
Product	RapidSE Zigbee Smart Energy Module ZGB.MMB-PA-LNA.1.0 and ZGB.MMB.-PA.1.0	
Standard(s)	RSS 210 Issue 6:2005 / FCC Part 15 Subpart C 15:2006	

Test Results Summary

Standard/Method	Description	Class/Limit	Result
FCC 15.203	Antenna Requirement	Unique	Pass See Justification
FCC 15.205 RSS 210 (Table 1)	Restricted Bands for intentional operation	QuasiPeak Average	Pass
FCC 15.207	Power line conducted emissions	QuasiPeak Average	Pass
FCC 15.209 RSS-210 (Table 2)	Spurious Radiated emissions	QuasiPeak Average	Pass
FCC 15.247(a)2 RSS-210 A8.2(a)	6 dB Bandwidth	> 500 kHz	Pass
FCC 15.247(b)2 RSS-210 A8.4(4)	Max output power	< 1 Watt	Pass
FCC 15.247(b)(4) RSS-210 A8.4(5)	Antenna Gain	< 6 dBi	Pass
FCC 15.247(d) RSS-210 A8.5	Antenna conducted spurious	< 20 dBc	Pass
FCC 15.247(e) RSS-210 A8.2(b)	Spectral Density	< 8 dBm (3 kHz BW)	Pass
FCC 15.247(i) IC Safety code 6	Maximum Permissible Exposure	> 20 cm separation.	Pass See justification and calculations
Overall Result			PASS

All tests were performed by Ashwani Malhotra

If the product as tested or otherwise complies with the specification, the EUT is deemed to comply with the requirement and is deemed a 'PASS' grade. If not 'FAIL' grade will be issued. Note that 'PASS' / 'FAIL' grade is independent of any measurement uncertainties. A 'PASS' / 'FAIL' grade within measurement uncertainty is marked with a '*'.

Client	MMB Research	
Product	RapidSE Zigbee Smart Energy Module ZGB.MMB-PA-LNA.1.0 and ZGB.MMB.-PA.1.0	
Standard(s)	RSS 210 Issue 6:2005 / FCC Part 15 Subpart C 15:2006	

Justifications, Descriptions, or Deviations

The following justifications for tests not performed or deviations from the above listed specifications apply:

For the Antenna requirement specified in FCC 15.203 (RSS 210 section 5.5), the unit uses a PCB antenna, gain of this antenna is less than 6 dbi.

There are two product variants for this device (ZGB.MMB-PA-LNA.1.0 and ZGB.MMB.-PA.1.0). ZGB.MMB-PA-LNA.1.0 has a low noise amplifier while the ZGB.MMB.-PA.1.0 variant does not. All tests were performed with the unit that has the low noise amplifier, spurious emissions were verified on the unit that has no low noise amplifier.

The EUT is duty cycled during the course of operation. As per the manufacturer of the chip, the maximum duty cycle the unit can operate on is 27%. Actual measured duty cycle was 460 usec with a repetition rate of 1s(duty cycle = 0.046 %).

For the Restricted Bands of operation, the EUT is designed to only operate between 2400 – 2480.0MHz.

For the scope of this testing the EUT was mounted horizontally and vertically to maximize emissions.

For maximum permissible exposure, this device operates at less than 1 Watt at 2400 – 2480.0 MHz and is designed to operate greater than 20 cm from personnel during normal operation. No testing is required, however worst case calculated exposure compliance follows later in this report.

The EUT is not a hybrid system and FCC 15.247 (f) does not apply to it. However the 15.247 (d) requirement of power density were met and are detailed later in this test report.

Client	MMB Research	
Product	RapidSE Zigbee Smart Energy Module ZGB.MMB-PA-LNA.1.0 and ZGB.MMB.-PA.1.0	
Standard(s)	RSS 210 Issue 6:2005 / FCC Part 15 Subpart C 15:2006	

Applicable Standards, Specifications and Methods

- ANSI C63.4:2003 - Methods of Measurement of Radio-Noise Emissions from Low-Voltage Electrical and Electronic Equipment in the Range of 9 kHz to 40 GHz
- CFR 47 FCC 15 - Code of Federal Regulations – Radio Frequency Devices
- CISPR 22:1997 - Information technology equipment – Radio disturbance characteristics – Limits and methods of measurement
- ICES-003:2004 - Digital Apparatus - Spectrum Management and Telecommunications Policy Interference-Causing Equipment Standard
- ISO 17025:2005 - General Requirements for the competence of testing and calibration laboratories
- RSS 210:2005 - Issue 6: Spectrum Management and Telecommunications Policy. Radio Standards Specification Low Power Licence-Exempt Radiocommunication Devices

Client	MMB Research	
Product	RapidSE Zigbee Smart Energy Module ZGB.MMB-PA-LNA.1.0 and ZGB.MMB.-PA.1.0	
Standard(s)	RSS 210 Issue 6:2005 / FCC Part 15 Subpart C 15:2006	

Sample calculation(s)

Margin = limit – (received signal + antenna factor + cable loss – pre-amp gain)

Margin = 50.5dBuV/m – (50dBuV + 10dB + 2.5dB – 20dB)

Margin = 8.5 dB

Document Revision Status

Revision 1 - Sept 16th, 2009

Client	MMB Research	
Product	RapidSE Zigbee Smart Energy Module ZGB.MMB-PA-LNA.1.0 and ZGB.MMB.-PA.1.0	
Standard(s)	RSS 210 Issue 6:2005 / FCC Part 15 Subpart C 15:2006	

Definitions and Acronyms

The following definitions and acronyms are applicable in this report.
See also ANSI C63.14.

AE – Auxillary Equipment.

BW – Bandwidth. Unless otherwise stated, this is refers to the 6 dB bandwidth.

EMC – Electro-Magnetic Compatibility

EMI – Electro-Magnetic Immunity

EUT – Equipment Under Test

ITE – Information Technology Equipment with a primary function(s) of entry, storage, display, retrieval, transmission, processing, switching, or control, of data.

LISN – Line impedance stabilization network

NCR – No Calibration Required

RF – Radio Frequency

Client	MMB Research	
Product	RapidSE Zigbee Smart Energy Module ZGB.MMB-PA-LNA.1.0 and ZGB.MMB.-PA.1.0	
Standard(s)	RSS 210 Issue 6:2005 / FCC Part 15 Subpart C 15:2006	

Testing Facility

Testing for EMC on the EUT was carried out at Global EMC labs in Toronto, Ontario, Canada. The testing lab consists of a 3m semi-anechoic chamber calibrated to be able to allow measurements on an EUT with a maximum width or length of up to 2m and height up to 3m. The chamber is equipped with a turn table that is capable of testing devices up to 3300lb in weight. This facility is capable of testing products that are rated for 120 Vac and 240Vac single phase, or 208 Vac 3 phase input. DC capability is also available. The chamber is equipped with an antenna mast that controls polarization and height from the control room adjoining the shielded chamber. Radiated emissions measurements are performed using a Bilog, and Horn antenna where applicable. Conducted emissions, unless otherwise stated, are performed using a LISN.

Calibrations and Accreditations

The measurement site used is registered with Federal Communications Commission (FCC) and Industry Canada (IC). This site is calibrated for Normalized Site Attenuation (NSA) using test procedures outlined in ANSI C63.4 “Methods of Measurement of Radio-Noise Emissions from Low-Voltage Electrical and Electronic Equipment in the Range of 9 kHz to 40 GHz”. The semi-anechoic chamber is lined with ferrite tiles and absorption cones to minimize any undesired reflections. All measuring equipment is calibrated on an annual or bi-annual basis as listed for each respective test.

Client	MMB Research	
Product	RapidSE Zigbee Smart Energy Module ZGB.MMB-PA-LNA.1.0 and ZGB.MMB.-PA.1.0	
Standard(s)	RSS 210 Issue 6:2005 / FCC Part 15 Subpart C 15:2006	

Testing Environmental Conditions and Dates

Following were the environmental conditions in the facility during time of testing –

Date	Test	Init.	Temperature (°C)	Humidity (%)	Pressure (kPa)
Sept 9 - 13, 2008	All	AM	23.5-24.1°C	39-42%	99.8 -100.5 kPa

Client	MMB Research	
Product	RapidSE Zigbee Smart Energy Module ZGB.MMB-PA-LNA.1.0 and ZGB.MMB.-PA.1.0	
Standard(s)	RSS 210 Issue 6:2005 / FCC Part 15 Subpart C 15:2006	

Detailed Test Results Section

Client	MMB Research	
Product	RapidSE Zigbee Smart Energy Module ZGB.MMB-PA-LNA.1.0 and ZGB.MMB.-PA.1.0	
Standard(s)	RSS 210 Issue 6:2005 / FCC Part 15 Subpart C 15:2006	

Spurious Radiated Emissions

Purpose

The purpose of this test is to ensure that the RF energy unintentionally emitted from the EUT does not exceed the limits listed below as defined in the applicable test standard, as measured from a receiving antenna. This helps protect broadcast radio services such as television, FM radio, pagers, cellular telephones, emergency services, and so on, from unwanted interference.

Limit(s) and Method

The method is as defined in ANSI C63.4:2003.

The limits, as defined in 15.247(d) for unintentional radiated emissions apply for those emissions that fall in the restricted bands, as defined in Section 15.205(a). These emissions must comply with the radiated emission limits specified in Section 15.209(a).

All unintentional emissions must also meet the ‘Spurious Conducted Emissions’ requirements of -20 dBc or greater. See also ‘Spurious Conducted Emissions’ for further details.

30 MHz – 88 MHz, 100 uV/m (40.0 dBuV/m¹) at 3 m
88 MHz – 216 MHz, 150 uV/m (43.5 dBuV/m¹) at 3 m
216 MHz – 960 MHz, 200 uV/m (46.4 dBuV/m¹) at 3 m
Above 960 MHz, 500 uV/m (54.0 dBuV/m¹) at 3 m
Above 1000 MHz, 500 uV/m (54.0 dBuV/m²) at 3m

¹Limit is with 120 kHz measurement bandwidth and a using a Quasi Peak detector.

²Limit is with 1 MHz measurement bandwidth and using an Average detector, scanned in accordance with 15.33 to above the 10th harmonic.

Client	MMB Research	
Product	RapidSE Zigbee Smart Energy Module ZGB.MMB-PA-LNA.1.0 and ZGB.MMB.-PA.1.0	
Standard(s)	RSS 210 Issue 6:2005 / FCC Part 15 Subpart C 15:2006	

Typical Radiated Emissions Setup

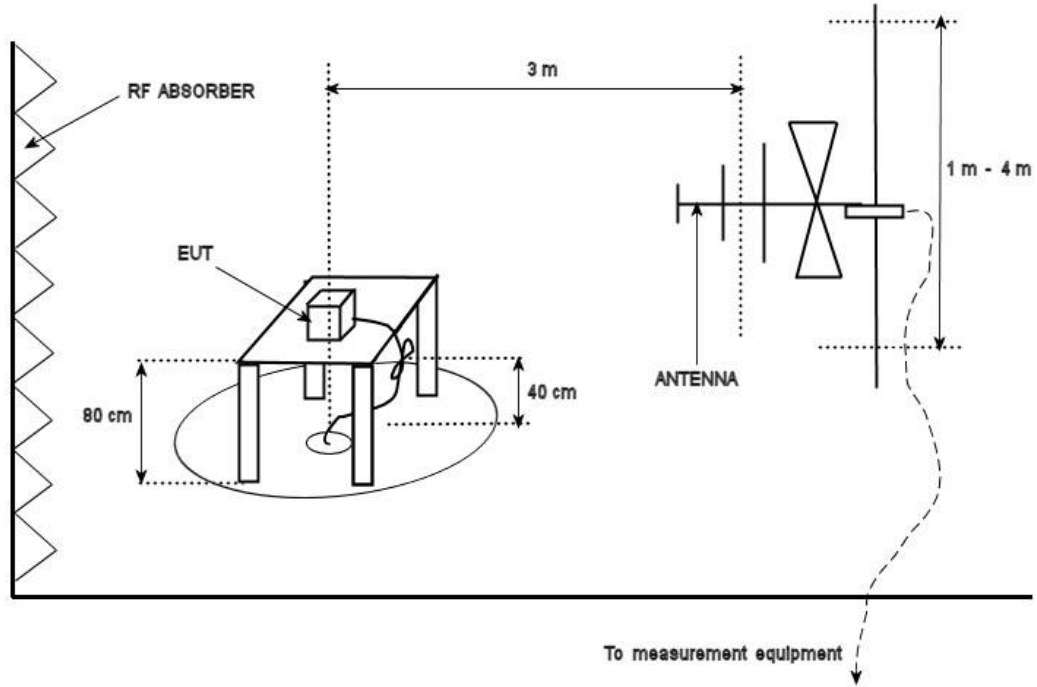

Client	MMB Research	
Product	RapidSE Zigbee Smart Energy Module ZGB.MMB-PA-LNA.1.0 and ZGB.MMB.-PA.1.0	
Standard(s)	RSS 210 Issue 6:2005 / FCC Part 15 Subpart C 15:2006	

Measurement Uncertainty

The expanded measurement uncertainty is calculated in accordance with CISPR 16-4-2 and is +/-4.4 dB with a 'k=2' coverage factor and a %95 confidence level.

Preliminary Graphs

Note the graphs shown below are for graphical illustration only. For final measurements with the appropriate detector, please refer to the final measurement table where applicable. The graph shown below is a maximized peak measurement graph, measured with a resolution bandwidth greater than the final required detector and over a full 0-360 rotation. This peaking process is done as a worst case measurement. This process enables the detection of frequencies of concern for final measurement, and provides considerable time savings.

In accordance with FCC Part 15, Subpart A, Section 15.33, the device was scanned to a minimum of a 25 GHz.

Client	MMB Research	
Product	RapidSE Zigbee Smart Energy Module ZGB.MMB-PA-LNA.1.0 and ZGB.MMB.-PA.1.0	
Standard(s)	RSS 210 Issue 6:2005 / FCC Part 15 Subpart C 15:2006	

Hi Channel – 30MHz – 1 GHz
Vertical – Peak Emissions Graph

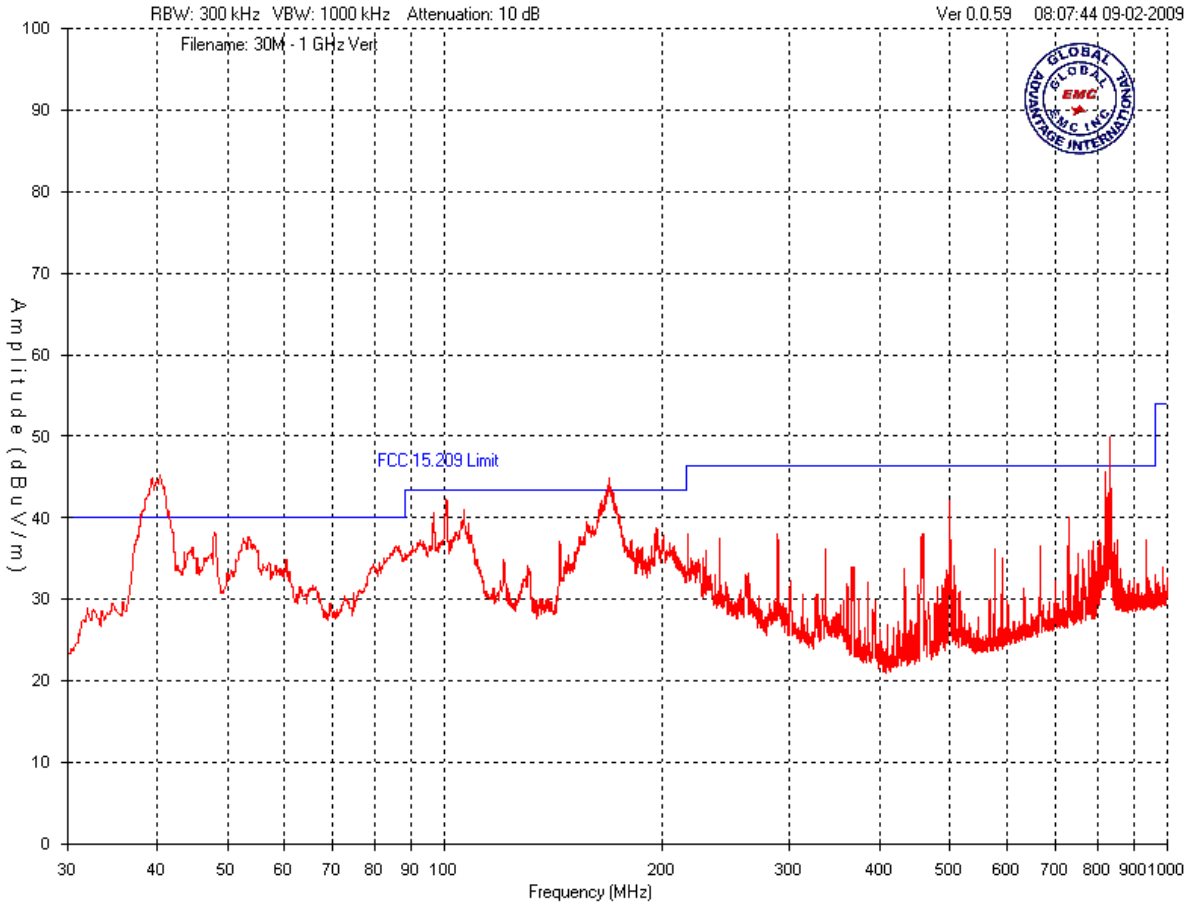

Client	MMB Research
Product	RapidSE Zigbee Smart Energy Module ZGB.MMB-PA-LNA.1.0 and ZGB.MMB.-PA.1.0
Standard(s)	RSS 210 Issue 6:2005 / FCC Part 15 Subpart C 15:2006



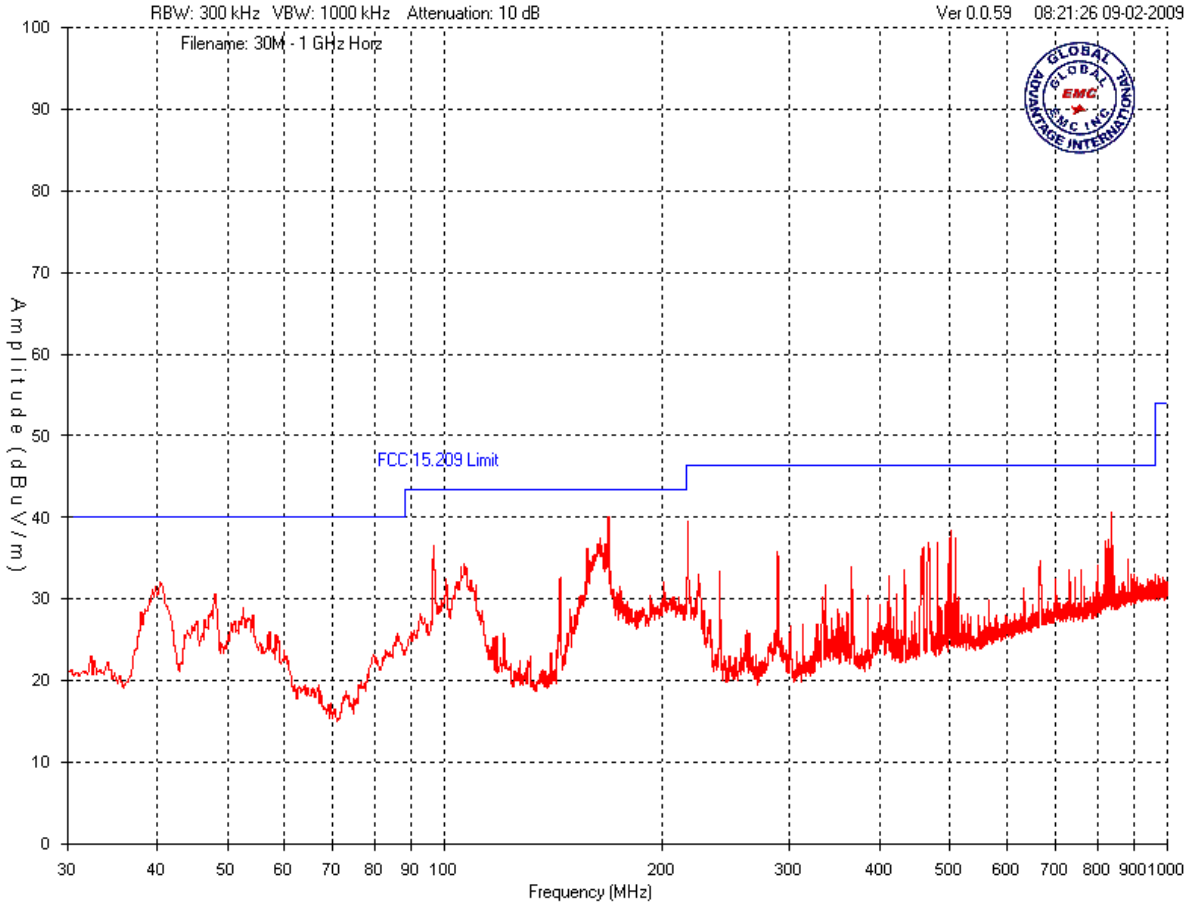

Hi Channel – 30MHz – 1 GHz
Horizontal – Peak Emissions Graph

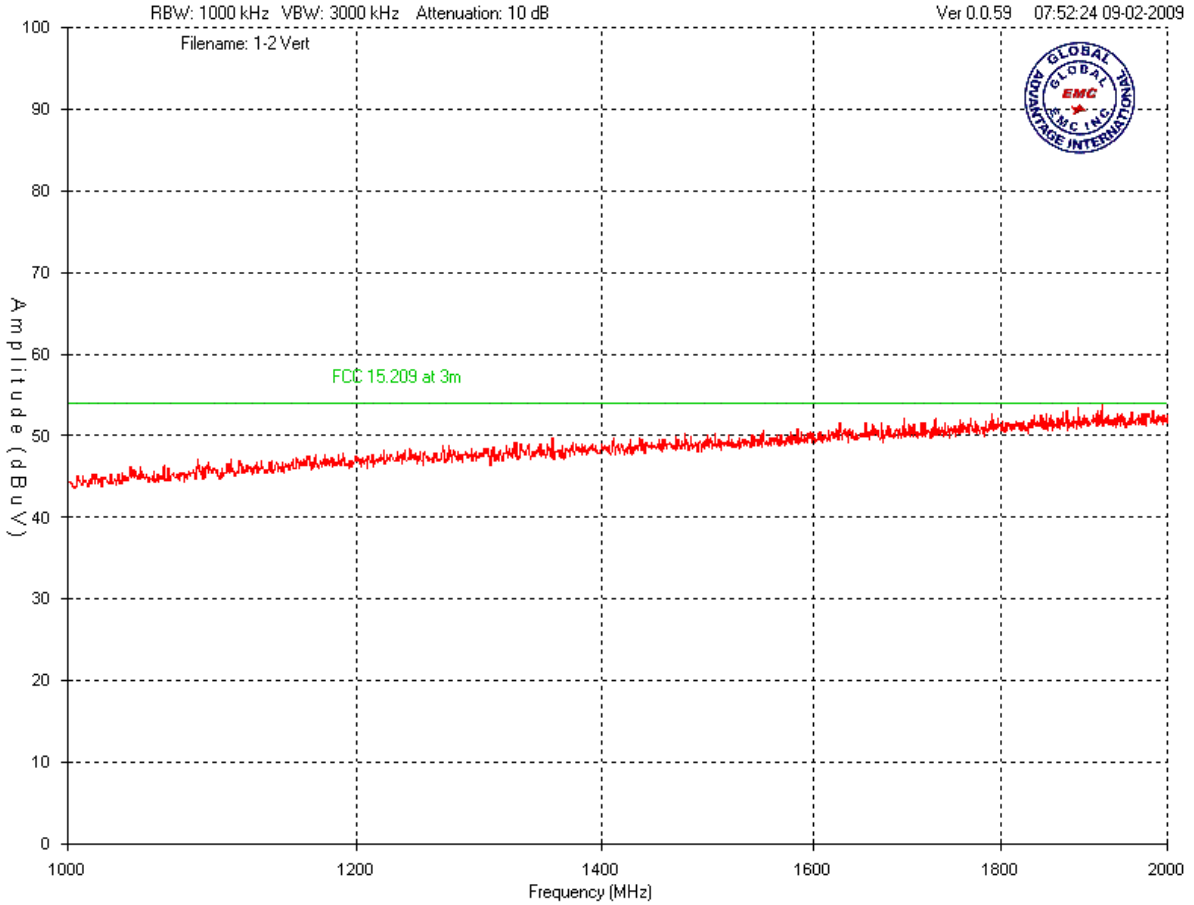

Client	MMB Research	
Product	RapidSE Zigbee Smart Energy Module ZGB.MMB-PA-LNA.1.0 and ZGB.MMB.-PA.1.0	
Standard(s)	RSS 210 Issue 6:2005 / FCC Part 15 Subpart C 15:2006	

Hi Channel – 1 – 2GHz
Vertical – Peak Emissions Graph



Client	MMB Research	
Product	RapidSE Zigbee Smart Energy Module ZGB.MMB-PA-LNA.1.0 and ZGB.MMB.-PA.1.0	
Standard(s)	RSS 210 Issue 6:2005 / FCC Part 15 Subpart C 15:2006	

Hi Channel – 1 – 2GHz
Horizontal – Peak Emissions Graph

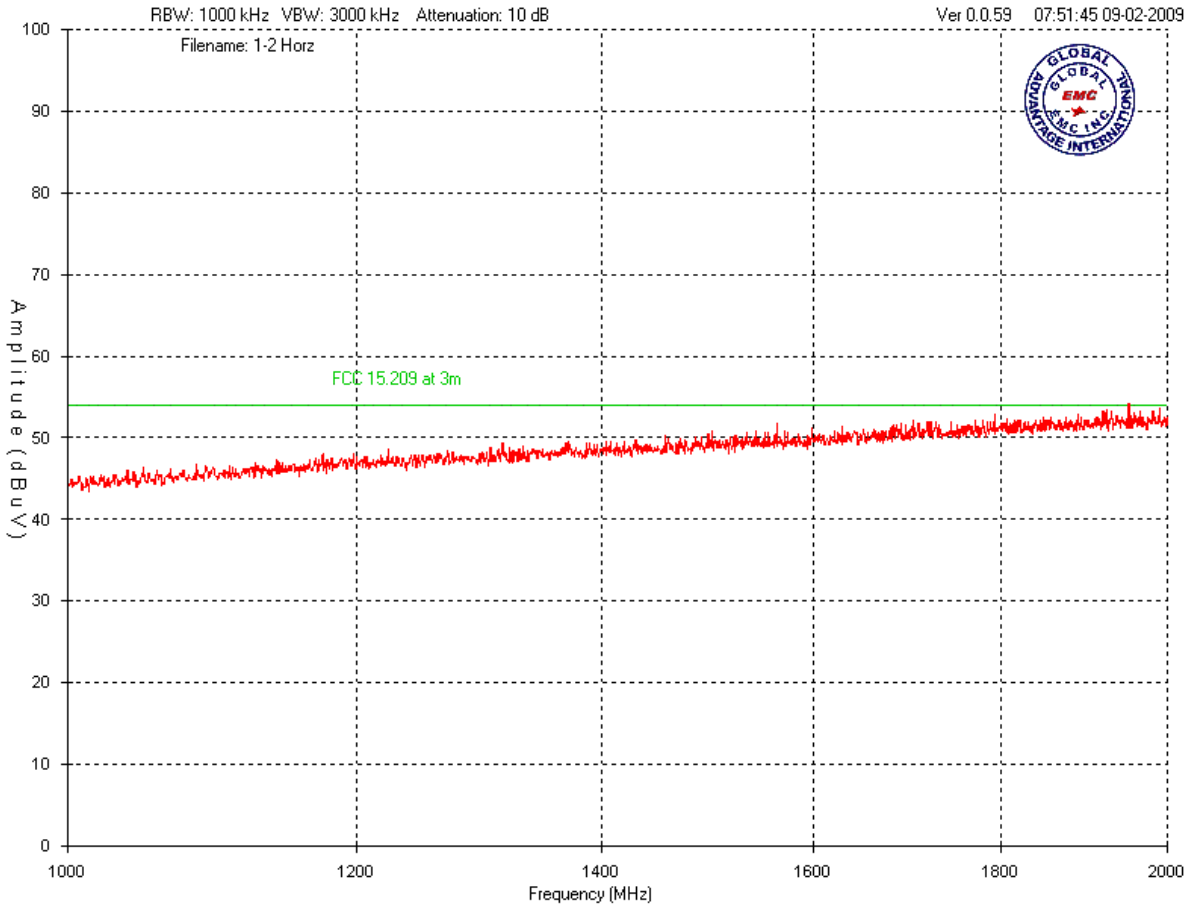

Client	MMB Research	
Product	RapidSE Zigbee Smart Energy Module ZGB.MMB-PA-LNA.1.0 and ZGB.MMB.-PA.1.0	
Standard(s)	RSS 210 Issue 6:2005 / FCC Part 15 Subpart C 15:2006	

Hi Channel – 2-5.5 GHz
Vertical – Peak Emissions Graph

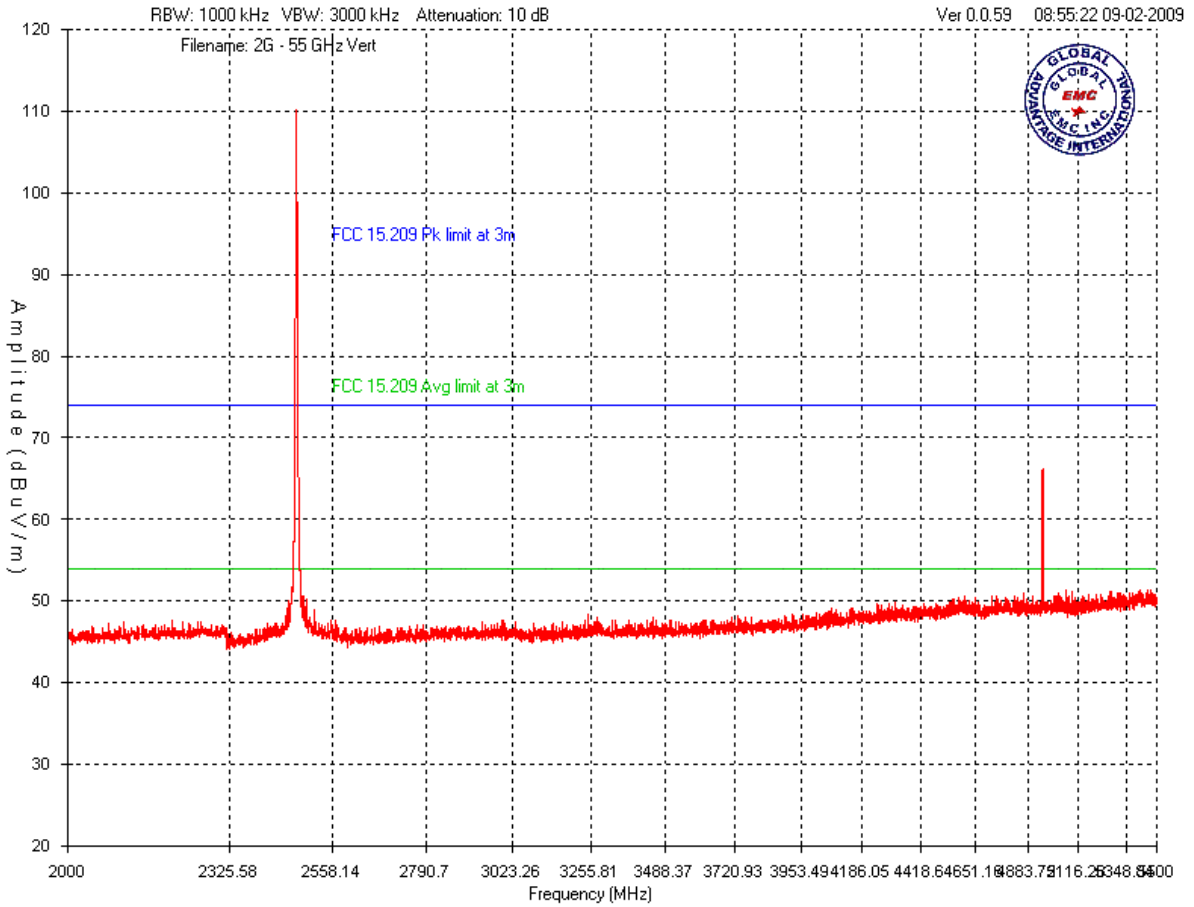

Client	MMB Research
Product	RapidSE Zigbee Smart Energy Module ZGB.MMB-PA-LNA.1.0 and ZGB.MMB.-PA.1.0
Standard(s)	RSS 210 Issue 6:2005 / FCC Part 15 Subpart C 15:2006



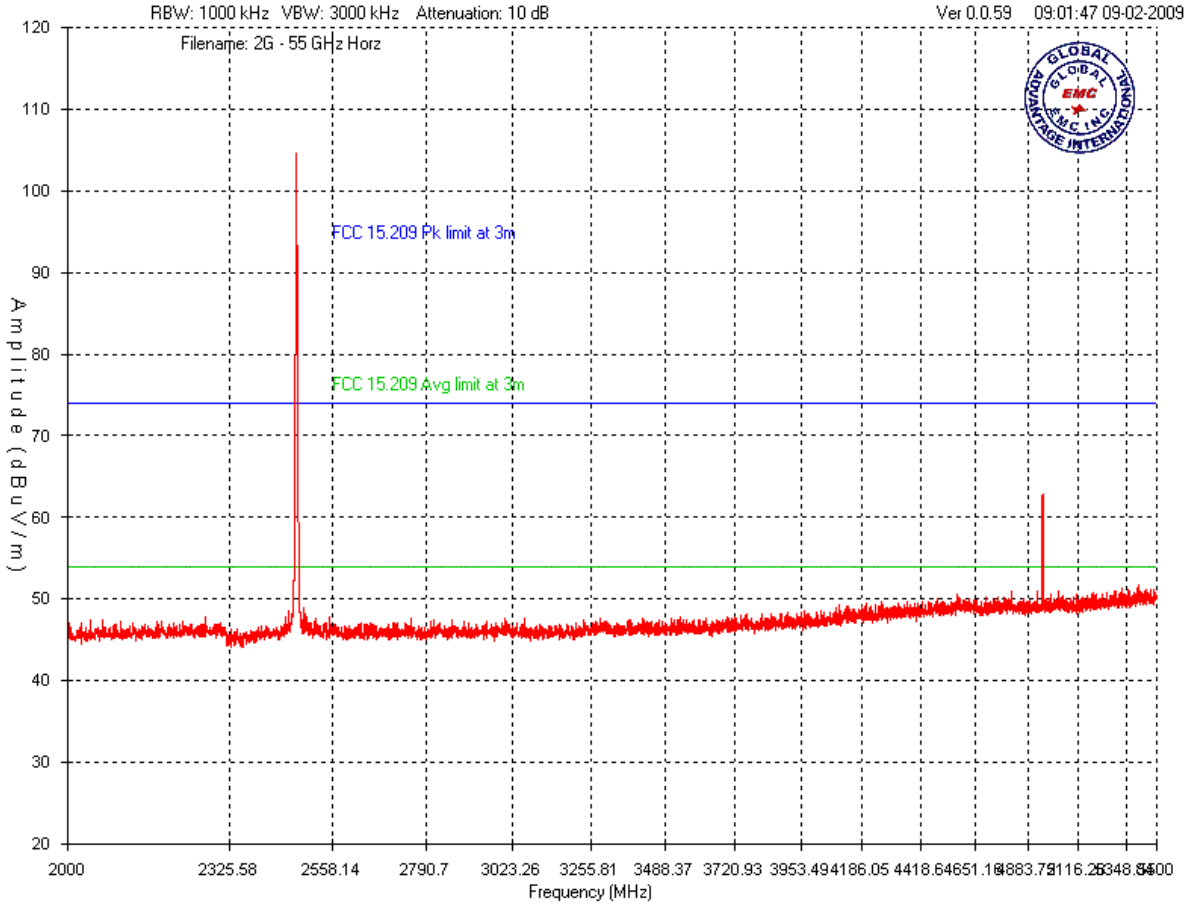

Hi Channel – 2-5.5 GHz
Horizontal – Peak Emissions Graph

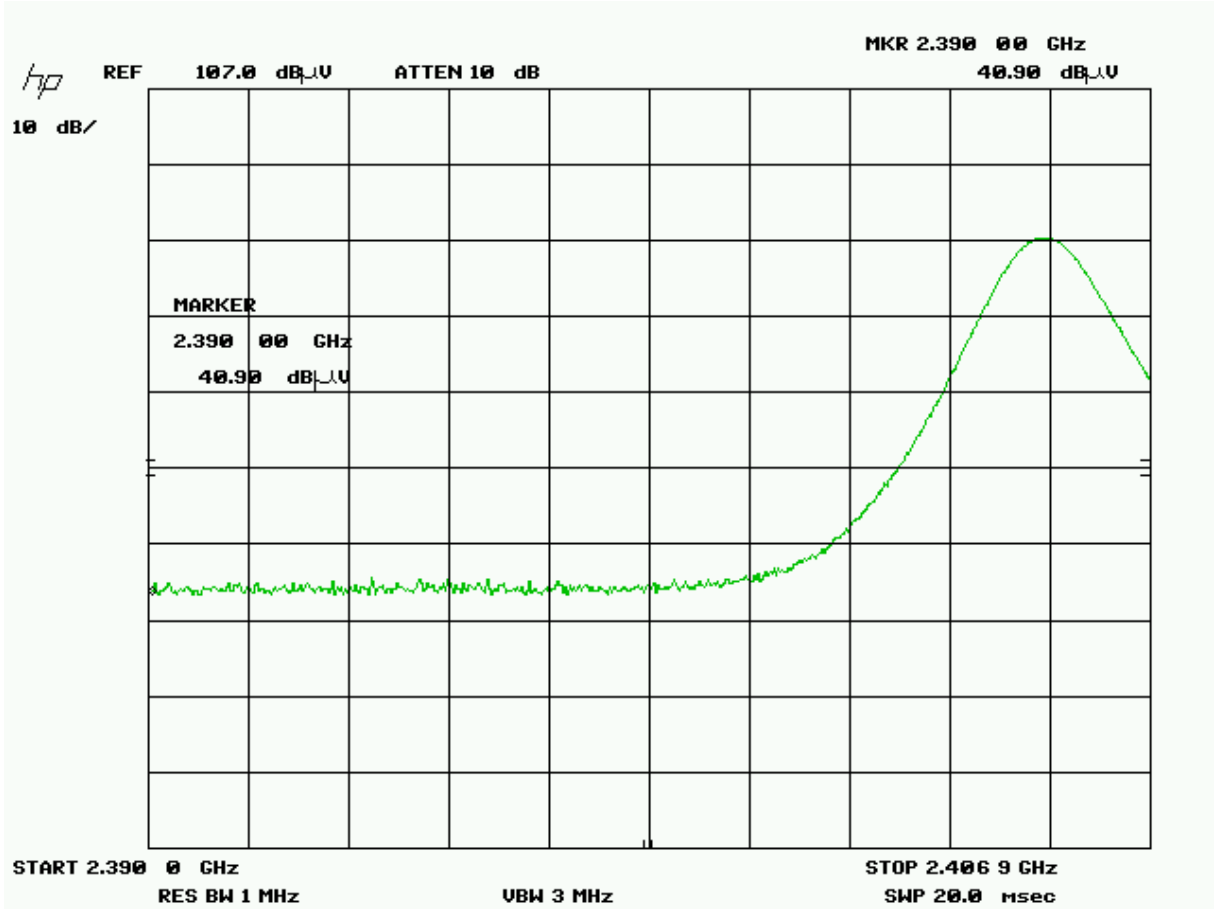

Client	MMB Research	
Product	RapidSE Zigbee Smart Energy Module ZGB.MMB-PA-LNA.1.0 and ZGB.MMB.-PA.1.0	
Standard(s)	RSS 210 Issue 6:2005 / FCC Part 15 Subpart C 15:2006	

Band Edge – Low channel
Vertical peak emissions



Client	MMB Research	
Product	RapidSE Zigbee Smart Energy Module ZGB.MMB-PA-LNA.1.0 and ZGB.MMB.-PA.1.0	
Standard(s)	RSS 210 Issue 6:2005 / FCC Part 15 Subpart C 15:2006	

Band Edge – Low channel
Horizontal peak emissions

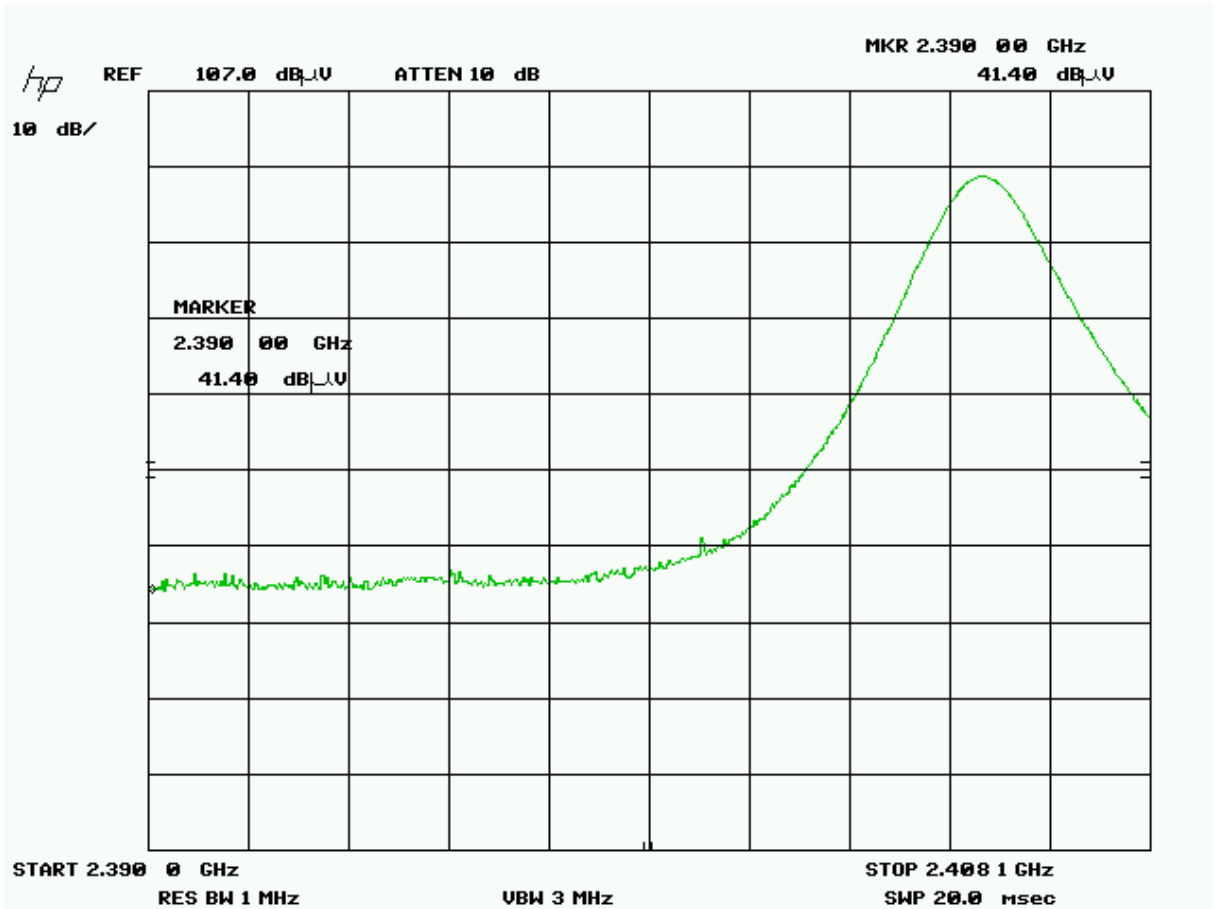

Client	MMB Research	
Product	RapidSE Zigbee Smart Energy Module ZGB.MMB-PA-LNA.1.0 and ZGB.MMB.-PA.1.0	
Standard(s)	RSS 210 Issue 6:2005 / FCC Part 15 Subpart C 15:2006	

Band Edge – Low channel
Vertical Average emissions



Client	MMB Research	
Product	RapidSE Zigbee Smart Energy Module ZGB.MMB-PA-LNA.1.0 and ZGB.MMB.-PA.1.0	
Standard(s)	RSS 210 Issue 6:2005 / FCC Part 15 Subpart C 15:2006	

Band Edge – Low channel
Horizontal Average emissions

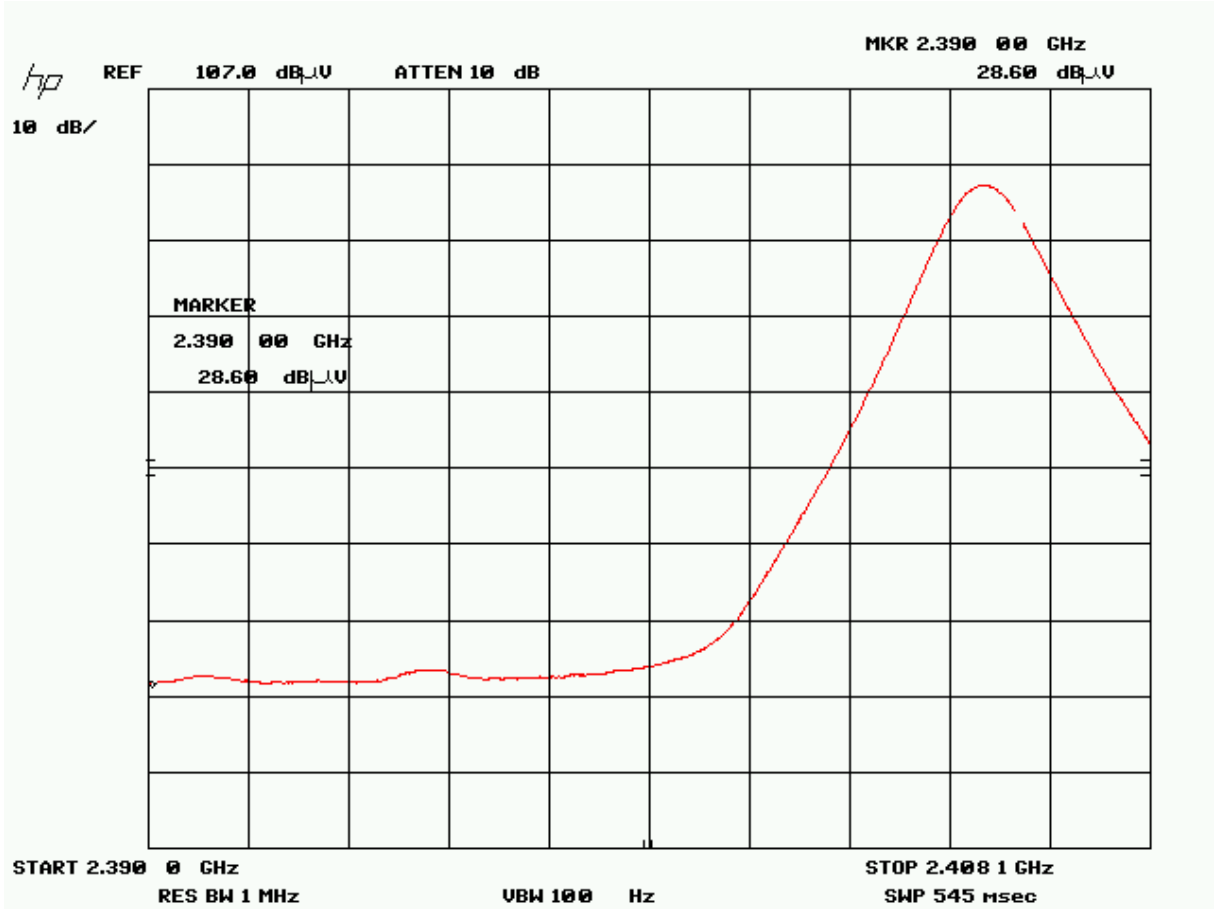

Client	MMB Research	
Product	RapidSE Zigbee Smart Energy Module ZGB.MMB-PA-LNA.1.0 and ZGB.MMB.-PA.1.0	
Standard(s)	RSS 210 Issue 6:2005 / FCC Part 15 Subpart C 15:2006	

Band Edge – Hi channel
Vertical peak emissions

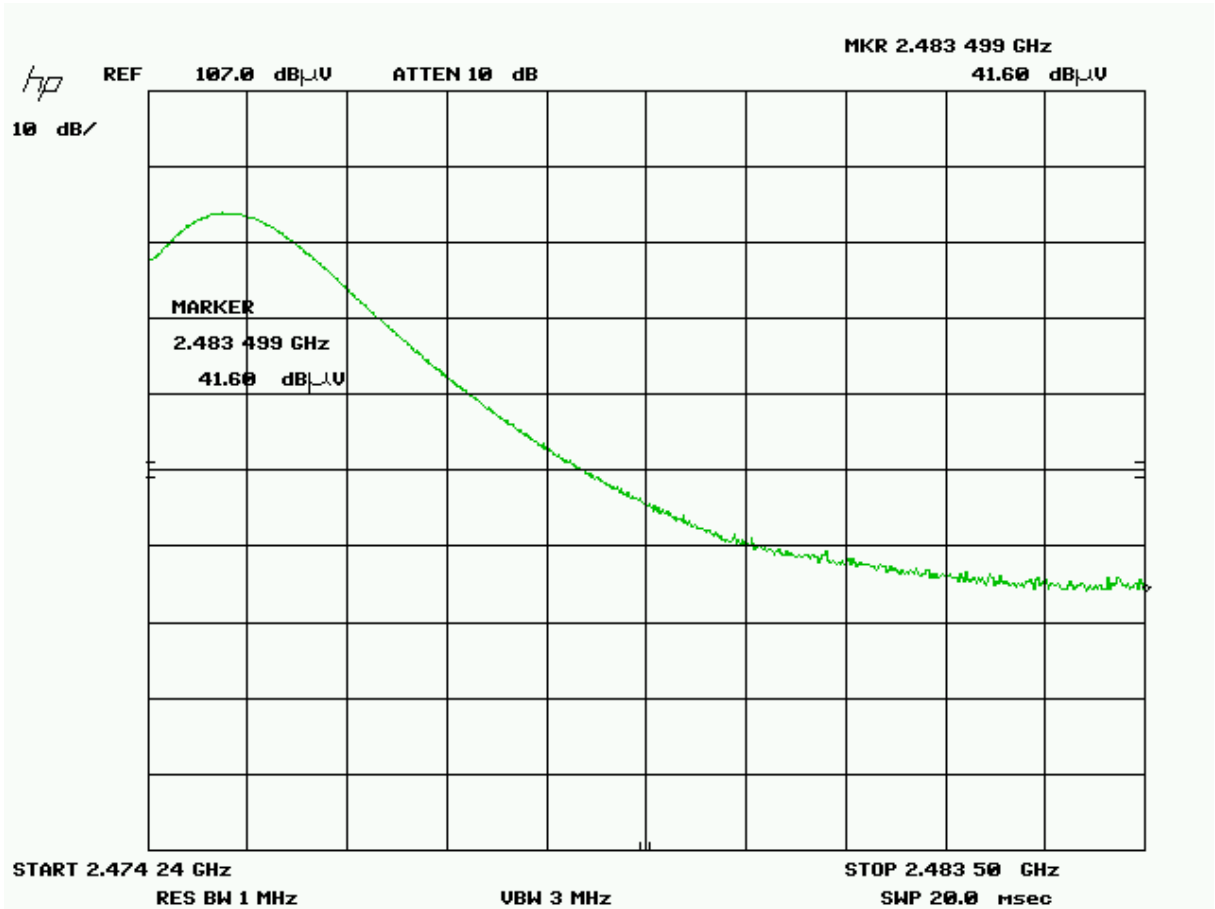

Client	MMB Research	
Product	RapidSE Zigbee Smart Energy Module ZGB.MMB-PA-LNA.1.0 and ZGB.MMB.-PA.1.0	
Standard(s)	RSS 210 Issue 6:2005 / FCC Part 15 Subpart C 15:2006	

Band Edge – Hi channel
Horizontal peak emissions



Client	MMB Research	
Product	RapidSE Zigbee Smart Energy Module ZGB.MMB-PA-LNA.1.0 and ZGB.MMB.-PA.1.0	
Standard(s)	RSS 210 Issue 6:2005 / FCC Part 15 Subpart C 15:2006	

Band Edge – Hi channel
Vertical Average emissions

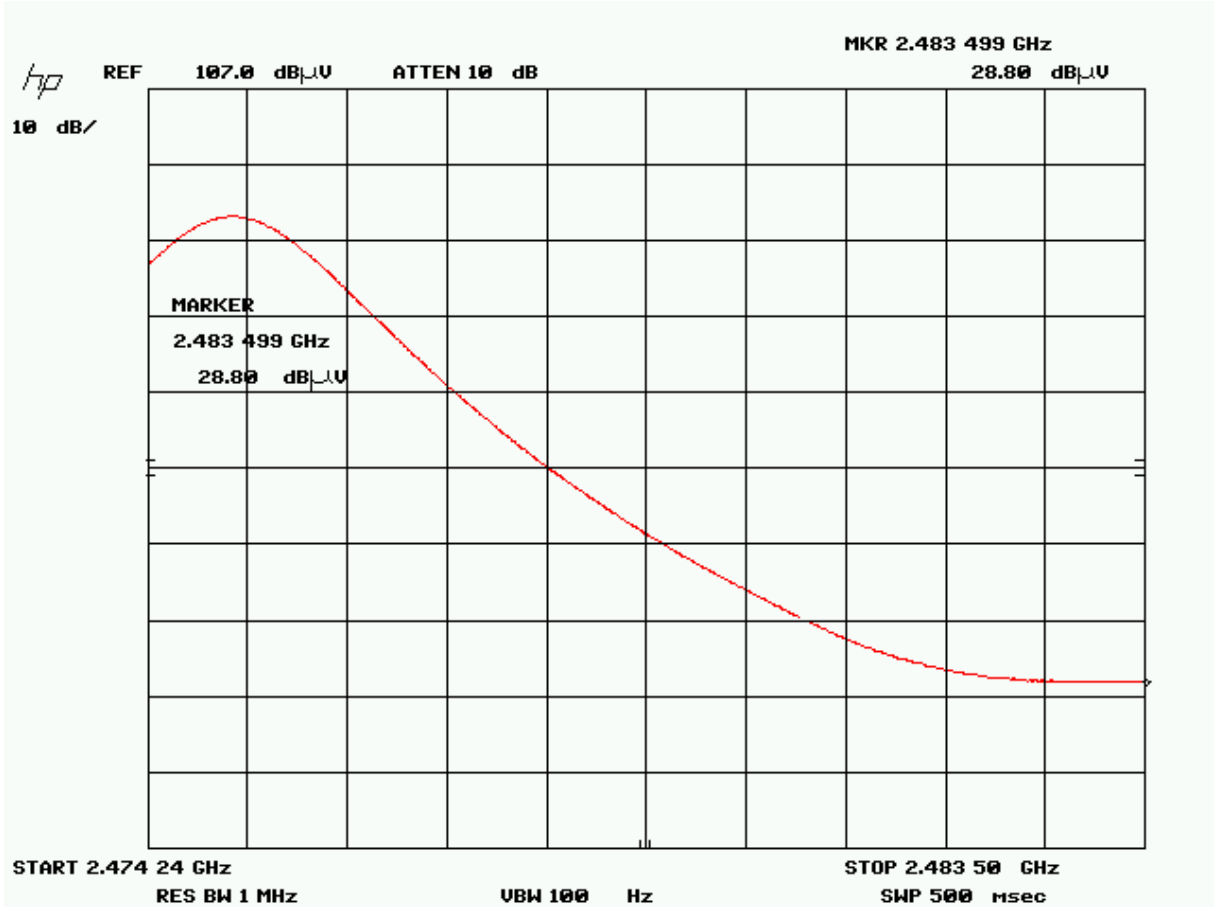

Client	MMB Research	
Product	RapidSE Zigbee Smart Energy Module ZGB.MMB-PA-LNA.1.0 and ZGB.MMB.-PA.1.0	
Standard(s)	RSS 210 Issue 6:2005 / FCC Part 15 Subpart C 15:2006	

Band Edge – Hi channel
Horizontal Average emissions

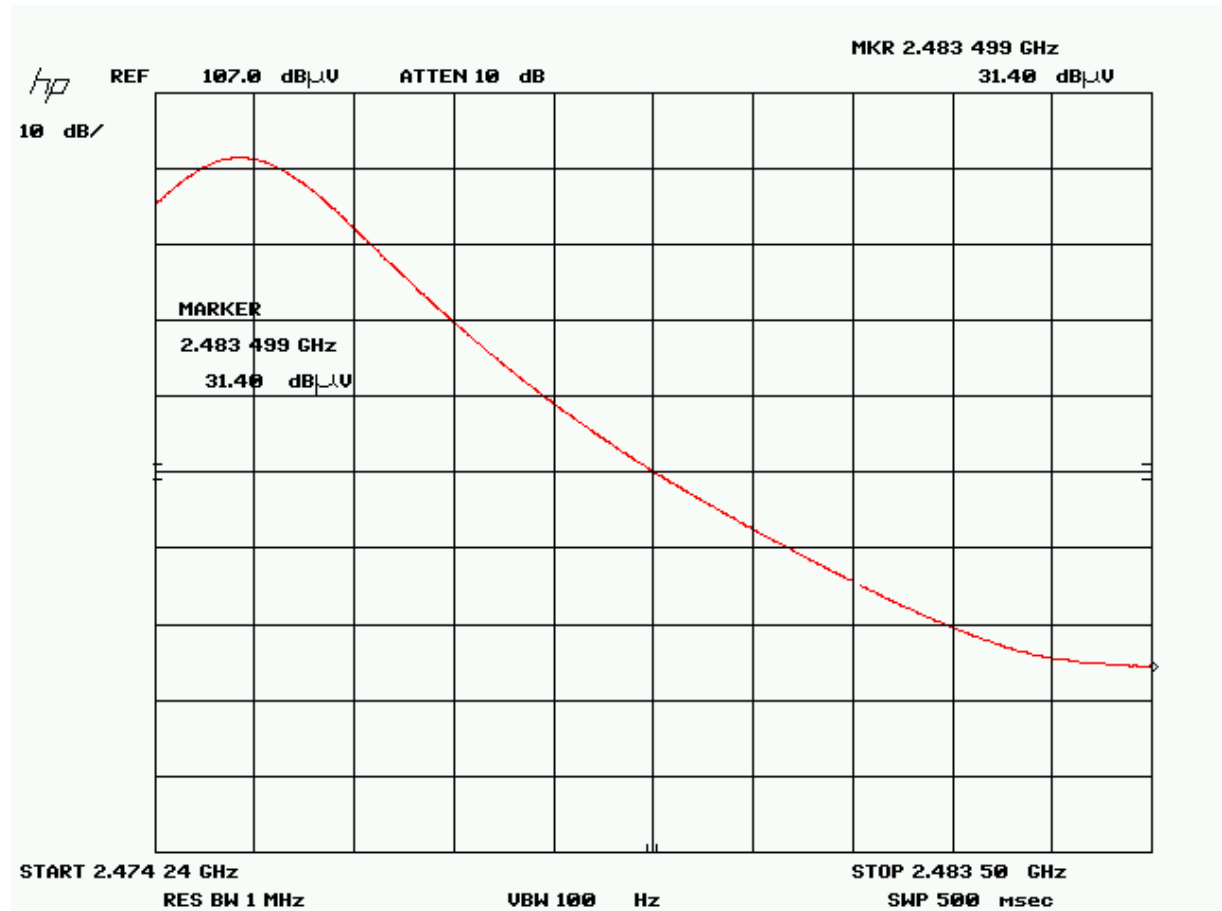

Client	MMB Research	
Product	RapidSE Zigbee Smart Energy Module ZGB.MMB-PA-LNA.1.0 and ZGB.MMB.-PA.1.0	
Standard(s)	RSS 210 Issue 6:2005 / FCC Part 15 Subpart C 15:2006	

On time for duty cycle

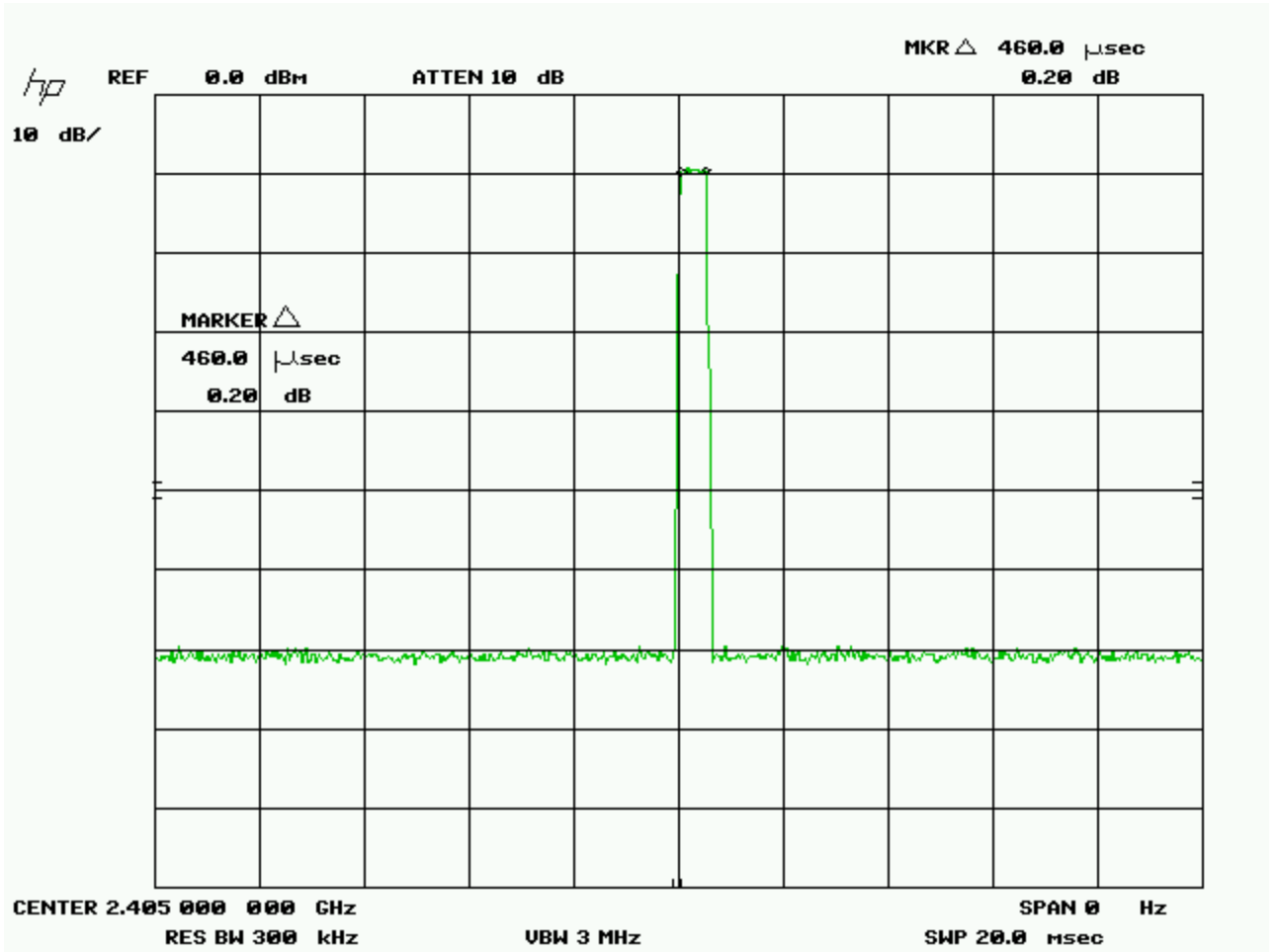

Client	MMB Research	
Product	RapidSE Zigbee Smart Energy Module ZGB.MMB-PA-LNA.1.0 and ZGB.MMB.-PA.1.0	
Standard(s)	RSS 210 Issue 6:2005 / FCC Part 15 Subpart C 15:2006	

Delta between transmission pulses

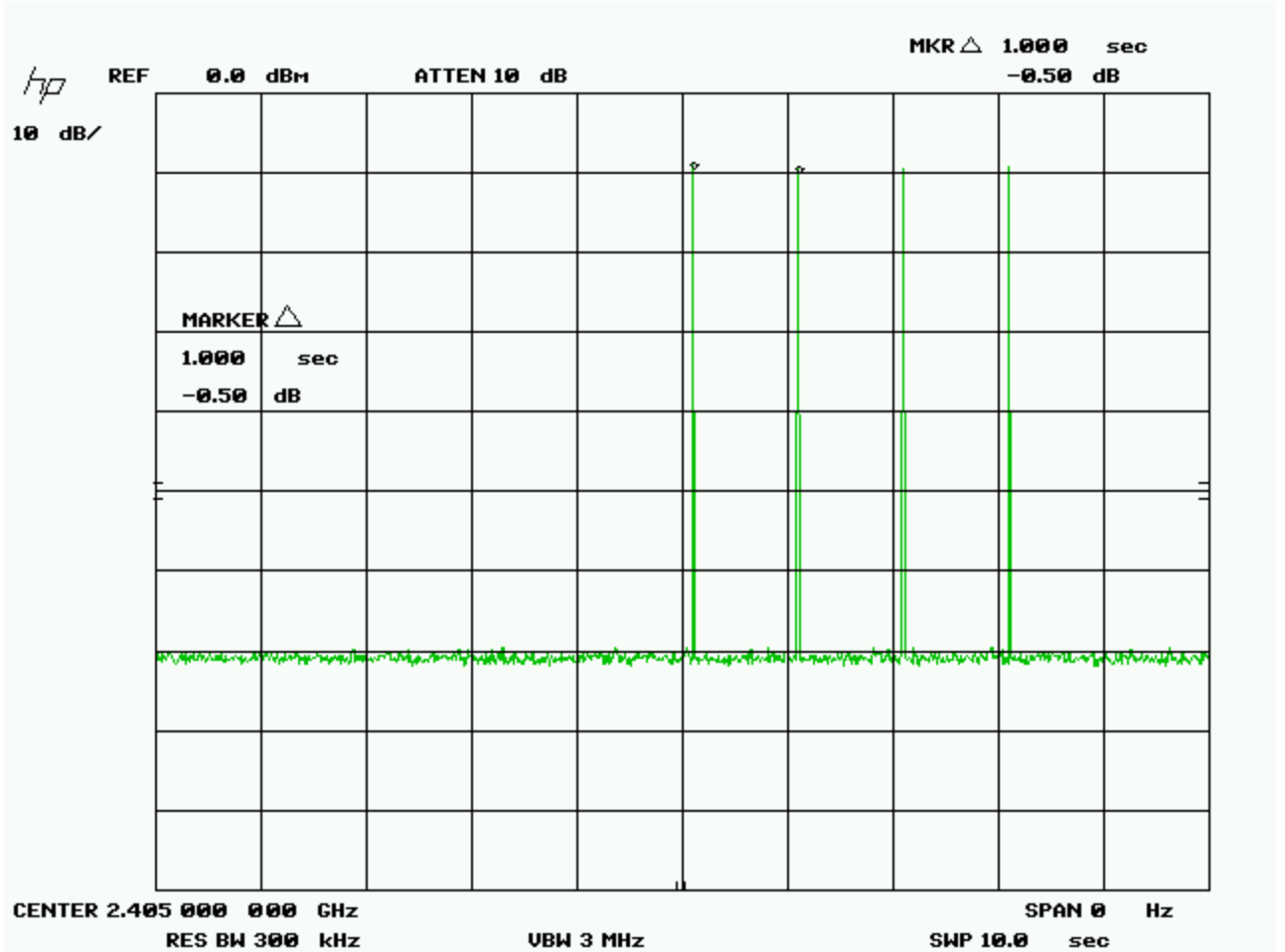

Client	MMB Research	
Product	RapidSE Zigbee Smart Energy Module ZGB.MMB-PA-LNA.1.0 and ZGB.MMB.-PA.1.0	
Standard(s)	RSS 210 Issue 6:2005 / FCC Part 15 Subpart C 15:2006	

Final Measurements

Note:

1. In accordance with 15.247(d), only radiated emissions exceeding the 15.209 limit that occur within the bands listed in 15.205, need to be verified with a quasi-peak detector or an average detector.
2. Hi channel had the worst case emissions and results are documented below in the test report.
3. Equipment uses a duty cycle and this factor was used for AVG measurements above 1 GHz. The maximum duty cycle the unit can theoretically operate on is 27%. Measure duty cycle was 0.046% (on time = 460 us and delta between spikes is 1s). $20 \log (0.27) = -11.3 \text{ db}$.

The requirement of -20dBc is verified by the conducted method; please see ‘Spurious Antenna Conducted Emissions’ section of this report.

Some of the frequencies shown on the peak graph do not fall within a restricted band as listed in FCC 15.205 and does not need to be verified.

For information purposes, the fundamental was measured to be 115.3 dBuV/m at 3 meters, and none of the unintentional radiated emissions that fall outside of the restricted bands exceeded the -20dBc (or 95.3 dBuV/m) requirement.

The following measurements were made at the harmonics shown in the above graphs.

See ‘Spurious Antenna Conducted Emissions’ measurements for -20 dBc requirements. No other emissions above the 2nd harmonic were detected.

Client	MMB Research	
Product	RapidSE Zigbee Smart Energy Module ZGB.MMB-PA-LNA.1.0 and ZGB.MMB.-PA.1.0	
Standard(s)	RSS 210 Issue 6:2005 / FCC Part 15 Subpart C 15:2006	

Radiated Emissions Measurements

Product category	FCC 15.247 Spurious Radiated Emissions										
Project Name / Number	RF Module										
Test Frequency (MHz)	Detection mode (Q-Peak)	Antenna polarity (Horz/Vert)	Raw signal dB(µV)	Antenna factor dB	Cable loss dB + Preselector	Attenuator dB	Pre-Amp Gain dB	Received signal dB(µV/m)	Emission limit dB(µV/m)	Margin dB(µV)	Result
Low Channel - Board Vertical (w LNA)											
2404	Peak	Vert	88.2	31.5	1.0	20.0	36.0	104.7			PASS
2404	Avg	Vert	87.5	31.5	1.0	20.0	36.0	104.0			PASS
2404	Peak	Horz	95.7	31.5	1.0	20.0	36.0	112.2			PASS
2404	Avg	Horz	94.3	31.5	1.0	20.0	36.0	110.8			PASS
2390	Peak	Horz	41.4	31.5	1.0	20.0	36.0	57.9	74.0	16.1	PASS
2390	Avg	Horz	30.0	31.5	1.0	20.0	36.0	46.5	54.0	7.5	PASS
2390	Peak	Vert	40.9	31.5	1.0	20.0	36.0	57.4	74.0	16.6	PASS
2390	Avg	Vert	29.5	31.5	1.0	20.0	36.0	46.0	54.0	8.0	PASS
4810	Peak	Horz	56.6	32.4	1.5	10.0	36.0	64.5	74.0	9.5	PASS
4810	Avg	Horz	45.2	32.4	1.5	10.0	36.0	53.1	54.0	0.9	PASS
4810	Peak	Vert	51.0	32.4	1.5	10.0	36.0	58.9	74.0	15.1	PASS

Client	MMB Research	
Product	RapidSE Zigbee Smart Energy Module ZGB.MMB-PA-LNA.1.0 and ZGB.MMB.-PA.1.0	
Standard(s)	RSS 210 Issue 6:2005 / FCC Part 15 Subpart C 15:2006	

4810	Avg	Vert	39.6	32.4	1.5	10.0	36.0	47.5	54.0	6.5	PASS
7212	Peak	Vert	50.1	38.0	1.7	10.0	35.8	64.0	74.0	10.0	PASS
7212	Avg	Vert	38.7	38.0	1.7	10.0	35.8	52.6	54.0	1.4	PASS
7212	Peak	Horz	49.9	38.0	1.7	10.0	35.8	63.8	74.0	10.2	PASS
7212	Avg	Horz	38.5	38.0	1.7	10.0	35.8	52.4	54.0	1.6	PASS
9616	Peak	Horz	48.5	39.0	1.7	10.0	35.8	63.4	74.0	10.6	PASS
9616	Avg	Horz	37.1	39.0	1.7	10.0	35.8	52.0	54.0	2.0	PASS
9616	Peak	Vert	47.2	39.0	1.7	10.0	35.8	62.1	74.0	11.9	PASS
9616	Avg	Vert	35.8	39.0	1.7	10.0	35.8	50.7	54.0	3.3	PASS
Mid Channel - Board Vertical (w LNA)											
2445	Peak	Vert	87.0	31.5	1.0	20.0	36.0	103.5			PASS
2445	Avg	Vert	86.9	31.5	1.0	20.0	36.0	103.4			PASS
2445	Peak	Horz	97.0	31.5	1.0	20.0	36.0	113.5			PASS
2445	Avg	Horz	96.0	31.5	1.0	20.0	36.0	112.5			PASS
4890	Peak	Horz	56.4	32.4	1.5	10.0	36.0	64.3	74.0	9.7	PASS
4890	Avg	Horz	45.0	32.4	1.5	10.0	36.0	52.9	54.0	1.1	PASS
4890	Peak	Vert	53.9	32.4	1.5	10.0	36.0	61.8	74.0	12.2	PASS
4890	Avg	Vert	42.5	32.4	1.5	10.0	36.0	50.4	54.0	3.6	PASS
7335	Peak	Vert	50.1	38.0	1.7	10.0	35.8	64.0	74.0	10.0	PASS
7335	Avg	Vert	38.7	38.0	1.7	10.0	35.8	52.6	54.0	1.4	PASS
7335	Peak	Horz	50.5	38.0	1.7	10.0	35.8	64.4	74.0	9.6	PASS

Client	MMB Research	
Product	RapidSE Zigbee Smart Energy Module ZGB.MMB-PA-LNA.1.0 and ZGB.MMB.-PA.1.0	
Standard(s)	RSS 210 Issue 6:2005 / FCC Part 15 Subpart C 15:2006	

7335	Avg	Horz	39.1	38.0	1.7	10.0	35.8	53.0	54.0	1.0	PASS
9780	Peak	Horz	49.2	39.0	1.7	10.0	35.8	64.1	74.0	9.9	PASS
9780	Avg	Horz	37.8	39.0	1.7	10.0	35.8	52.7	54.0	1.3	PASS
9780	Peak	Vert	49.0	39.0	1.7	10.0	35.8	63.9	74.0	10.1	PASS
9780	Avg	Vert	37.6	39.0	1.7	10.0	35.8	52.5	54.0	1.5	PASS
Hi Channel - Board Vertical (w LNA)											
2475	Peak	Horz	98.8	31.5	1.0	20.0	36.0	115.3			PASS
2475	Avg	Horz	98.6	31.5	1.0	20.0	36.0	115.1			PASS
2475	Peak	Vert	91.0	31.5	1.0	20.0	36.0	107.5			PASS
2475	Avg	Vert	90.2	31.5	1.0	20.0	36.0	106.7			PASS
2483.5	Peak	Horz	44.0	31.5	1.0	20.0	36.0	60.5	74.0	13.5	PASS
2483.5	Avg	Horz	32.6	31.5	1.0	20.0	36.0	49.1	54.0	4.9	PASS
2483.5	Peak	Vert	41.6	31.5	1.0	20.0	36.0	58.1	74.0	15.9	PASS
2483.5	Avg	Vert	30.2	31.5	1.0	20.0	36.0	46.7	54.0	7.3	PASS
4948	Peak	Horz	52.7	32.4	1.5	10.0	36.0	60.6	74.0	13.4	PASS
4848	Avg	Horz	41.3	32.4	1.5	10.0	36.0	49.2	54.0	4.8	PASS
4848	Peak	Vert	56.7	32.4	1.5	10.0	36.0	64.6	74.0	9.4	PASS
4948	Avg	Vert	45.3	32.4	1.5	10.0	36.0	53.2	54.0	0.8	PASS
7425	Peak	Vert	50.4	38.0	1.7	10.0	35.8	64.3	74.0	9.7	PASS
7425	Avg	Vert	39.0	38.0	1.7	10.0	35.8	52.9	54.0	1.1	PASS
7425	Peak	Horz	50.2	38.0	1.7	10.0	35.8	64.1	74.0	9.9	PASS

Client	MMB Research	
Product	RapidSE Zigbee Smart Energy Module ZGB.MMB-PA-LNA.1.0 and ZGB.MMB.-PA.1.0	
Standard(s)	RSS 210 Issue 6:2005 / FCC Part 15 Subpart C 15:2006	

7425	Avg	Horz	38.8	38.0	1.7	10.0	35.8	52.7	54.0	1.3	PASS
Low Channel - Board Vertical (w/o LNA)											
2404	Peak	Vert	87.1	31.5	1.0	20.0	36.0	103.6			PASS
2404	Avg	Vert	87.0	31.5	1.0	20.0	36.0	103.5			PASS
2404	Peak	Horz	93.7	31.5	1.0	20.0	36.0	110.2			PASS
2404	Avg	Horz	93.6	31.5	1.0	20.0	36.0	110.1			PASS
2390	Peak	Horz	39.7	31.5	1.0	20.0	36.0	56.2	74.0	17.8	PASS
2390	Avg	Horz	28.3	31.5	1.0	20.0	36.0	44.8	54.0	9.2	PASS
2390	Peak	Vert	40.0	31.5	1.0	20.0	36.0	56.5	74.0	17.5	PASS
2390	Avg	Vert	28.6	31.5	1.0	20.0	36.0	45.1	54.0	8.9	PASS
4810	Peak	Horz	53.3	32.4	1.5	10.0	36.0	61.2	74.0	12.8	PASS
4810	Avg	Horz	41.9	32.4	1.5	10.0	36.0	49.8	54.0	4.2	PASS
4810	Peak	Vert	53.1	32.4	1.5	10.0	36.0	61.0	74.0	13.0	PASS
4810	Avg	Vert	41.7	32.4	1.5	10.0	36.0	49.6	54.0	4.4	PASS
7212	Peak	Vert	45.0	38.0	1.7	10.0	35.8	58.9	74.0	15.1	PASS
7212	Avg	Vert	33.6	38.0	1.7	10.0	35.8	47.5	54.0	6.5	PASS
7212	Peak	Horz	50.3	38.0	1.7	10.0	35.8	64.2	74.0	9.8	PASS
7212	Avg	Horz	38.9	38.0	1.7	10.0	35.8	52.8	54.0	1.2	PASS
9616	Peak	Horz	47.4	39.0	1.7	10.0	35.8	62.3	74.0	11.7	PASS
9616	Avg	Horz	36.0	39.0	1.7	10.0	35.8	50.9	54.0	3.1	PASS
9616	Peak	Vert	47.2	39.0	1.7	10.0	35.8	62.1	74.0	11.9	PASS

Client	MMB Research	
Product	RapidSE Zigbee Smart Energy Module ZGB.MMB-PA-LNA.1.0 and ZGB.MMB.-PA.1.0	
Standard(s)	RSS 210 Issue 6:2005 / FCC Part 15 Subpart C 15:2006	

9616	Avg	Vert	35.8	39.0	1.7	10.0	35.8	50.7	54.0	3.3	PASS
Mid Channel - Board Vertical (w/o LNA)											
2445	Peak	Vert	88.9	31.5	1.0	20.0	36.0	105.4			PASS
2445	Avg	Vert	88.8	31.5	1.0	20.0	36.0	105.3			PASS
2445	Peak	Horz	95.1	31.5	1.0	20.0	36.0	111.6			PASS
2445	Avg	Horz	93.7	31.5	1.0	20.0	36.0	110.2			PASS
4890	Peak	Horz	52.3	32.4	1.5	10.0	36.0	60.2	74.0	13.8	PASS
4890	Avg	Horz	40.9	32.4	1.5	10.0	36.0	48.8	54.0	5.2	PASS
4890	Peak	Vert	53.0	32.4	1.5	10.0	36.0	60.9	74.0	13.1	PASS
4890	Avg	Vert	41.6	32.4	1.5	10.0	36.0	49.5	54.0	4.5	PASS
7335	Peak	Vert	46.9	38.0	1.7	10.0	35.8	60.8	74.0	13.2	PASS
7335	Avg	Vert	35.5	38.0	1.7	10.0	35.8	49.4	54.0	4.6	PASS
7335	Peak	Horz	49.2	38.0	1.7	10.0	35.8	63.1	74.0	10.9	PASS
7335	Avg	Horz	37.8	38.0	1.7	10.0	35.8	51.7	54.0	2.3	PASS
9780	Peak	Horz	47.6	39.0	1.7	10.0	35.8	62.5	74.0	11.5	PASS
9780	Avg	Horz	36.2	39.0	1.7	10.0	35.8	51.1	54.0	2.9	PASS
9780	Peak	Vert	46.7	39.0	1.7	10.0	35.8	61.6	74.0	12.4	PASS
9780	Avg	Vert	35.3	39.0	1.7	10.0	35.8	50.2	54.0	3.8	PASS
Hi Channel - Board Vertical (w/o LNA)											
2475	Peak	Horz	95.9	31.5	1.0	20.0	36.0	112.4			PASS
2475	Avg	Horz	95.2	31.5	1.0	20.0	36.0	111.7			PASS

Client	MMB Research	
Product	RapidSE Zigbee Smart Energy Module ZGB.MMB-PA-LNA.1.0 and ZGB.MMB.-PA.1.0	
Standard(s)	RSS 210 Issue 6:2005 / FCC Part 15 Subpart C 15:2006	

2475	Peak	Vert	89.6	31.5	1.0	20.0	36.0	106.1			PASS
2475	Avg	Vert	89.5	31.5	1.0	20.0	36.0	106.0			PASS
2483.5	Peak	Horz	43.0	31.5	1.0	20.0	36.0	59.5	74.0	14.5	PASS
2483.5	Avg	Horz	31.6	31.5	1.0	20.0	36.0	48.1	54.0	5.9	PASS
2483.5	Peak	Vert	40.8	31.5	1.0	20.0	36.0	57.3	74.0	16.7	PASS
2483.5	Avg	Vert	29.4	31.5	1.0	20.0	36.0	45.9	54.0	8.1	PASS
4948	Peak	Horz	53.2	32.4	1.5	10.0	36.0	61.1	74.0	12.9	PASS
4848	Avg	Horz	41.8	32.4	1.5	10.0	36.0	49.7	54.0	4.3	PASS
4848	Peak	Vert	51.6	32.4	1.5	10.0	36.0	59.5	74.0	14.5	PASS
4948	Avg	Vert	40.2	32.4	1.5	10.0	36.0	48.1	54.0	5.9	PASS
7425	Peak	Vert	50.7	38.0	1.7	10.0	35.8	64.6	74.0	9.4	PASS
7425	Avg	Vert	39.3	38.0	1.7	10.0	35.8	53.2	54.0	0.8	PASS
7425	Peak	Horz	50.4	38.0	1.7	10.0	35.8	64.3	74.0	9.7	PASS
7425	Avg	Horz	39.0	38.0	1.7	10.0	35.8	52.9	54.0	1.1	PASS

Client	MMB Research	
Product	RapidSE Zigbee Smart Energy Module ZGB.MMB-PA-LNA.1.0 and ZGB.MMB.-PA.1.0	
Standard(s)	RSS 210 Issue 6:2005 / FCC Part 15 Subpart C 15:2006	

Test Equipment List

Equipment	Model #	Manufacturer	Cal date	Due Date	Equipment ID#
Spectrum Analyzer	8566B	HP	2008-02-28	2010-02-28	GEMC 6
Quasi Peak Adapter	85650A	HP	2008-02-28	2010-02-28	GEMC 7
BiLog Antenna	3142-C	ETS	2009-02-12	2011-02-12	GEMC 8
RF Cable 7m	LMR-400-7M-50OHM-MN-MN	LexTec	NCR	NCR	GEMC 28
RF Cable 1m	LMR-400-1M-50OHM-MN-MN	LexTec	NCR	NCR	GEMC 29
RF Cable 1m	LMR-400-1M-50OHM-MN-MN	LexTec	NCR	NCR	GEMC 30
RF Cable 0.5M	LMR-400-0.5M-50OHM-MN-MN	LexTec	NCR	NCR	GEMC 31
Attenuator 3 dB	FP-50-3	Trilithic	NCR	NCR	GEMC 40
IFR Spectrum Analyzer	AN940	IFR	NCR	NCR	GEMC 6350
A.H. Systems Horn Antenna 18 GHz - 26.5 GHz	SAS-572	AH	NCR	NCR	GEMC 6371
Schaffner Preamp 9kHz - 2 GHz	CPA9231A	Schaffner	8/26/2008	8/26/2010	GEMC 116
Q-Par 1.5-18 GHz Horn	6878/24	Q-par	8/25/2008	8/25/2010	GEMC 6365
HP Preamp	HP-8449B	HP	8/25/2008	8/25/2010	GEMC 6351

This report module is based on GEMC template "FCC - 15.209 - Radiated Emissions_Rev2.doc"

Client	MMB Research	
Product	RapidSE Zigbee Smart Energy Module ZGB.MMB-PA-LNA.1.0 and ZGB.MMB.-PA.1.0	
Standard(s)	RSS 210 Issue 6:2005 / FCC Part 15 Subpart C 15:2006	

6dB Bandwidth of Digitally Modulated Systems

Purpose

The purpose of this test is to ensure that the bandwidth occupied exceeds a stated minimum. This helps ensure the utilization of the frequency allocation is sufficiently wide. This also helps prevent corruption of data by ensuring adequate data separation to distinguish the reception of the intended information.

Limits

Systems using digital modulation techniques may operate in the 902 - 928 MHz, 2400 - 2483.5 MHz, and 5725 - 5850 MHz bands. The minimum 6 dB bandwidth shall be at least 500 kHz. This should be measured with a 100 kHz RBW and a 300 kHz VBW.

Results

The EUT passed. The 6 dB BW measured was 1.55 MHz.

Client	MMB Research	
Product	RapidSE Zigbee Smart Energy Module ZGB.MMB-PA-LNA.1.0 and ZGB.MMB.-PA.1.0	
Standard(s)	RSS 210 Issue 6:2005 / FCC Part 15 Subpart C 15:2006	

Graph(s)

The graphs shown below show the channel spacing during the operation of the device. This is measured by a max hold on the spectrum analyzer. This measurement is a peak measurement. Max hold is performed for a duration of not less than 1 minute.

Low Channel

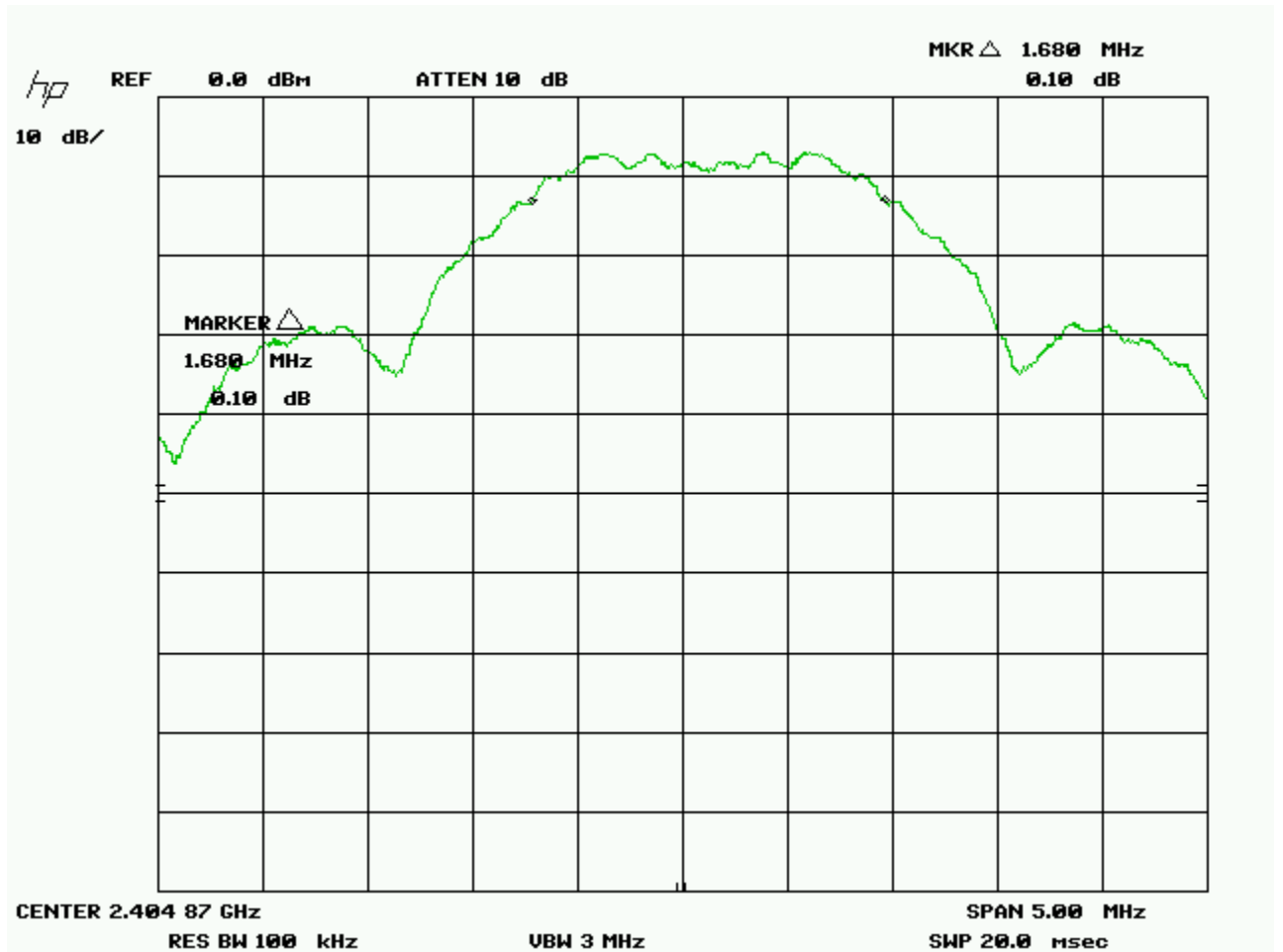

Client	MMB Research	
Product	RapidSE Zigbee Smart Energy Module ZGB.MMB-PA-LNA.1.0 and ZGB.MMB.-PA.1.0	
Standard(s)	RSS 210 Issue 6:2005 / FCC Part 15 Subpart C 15:2006	

Medium Channel

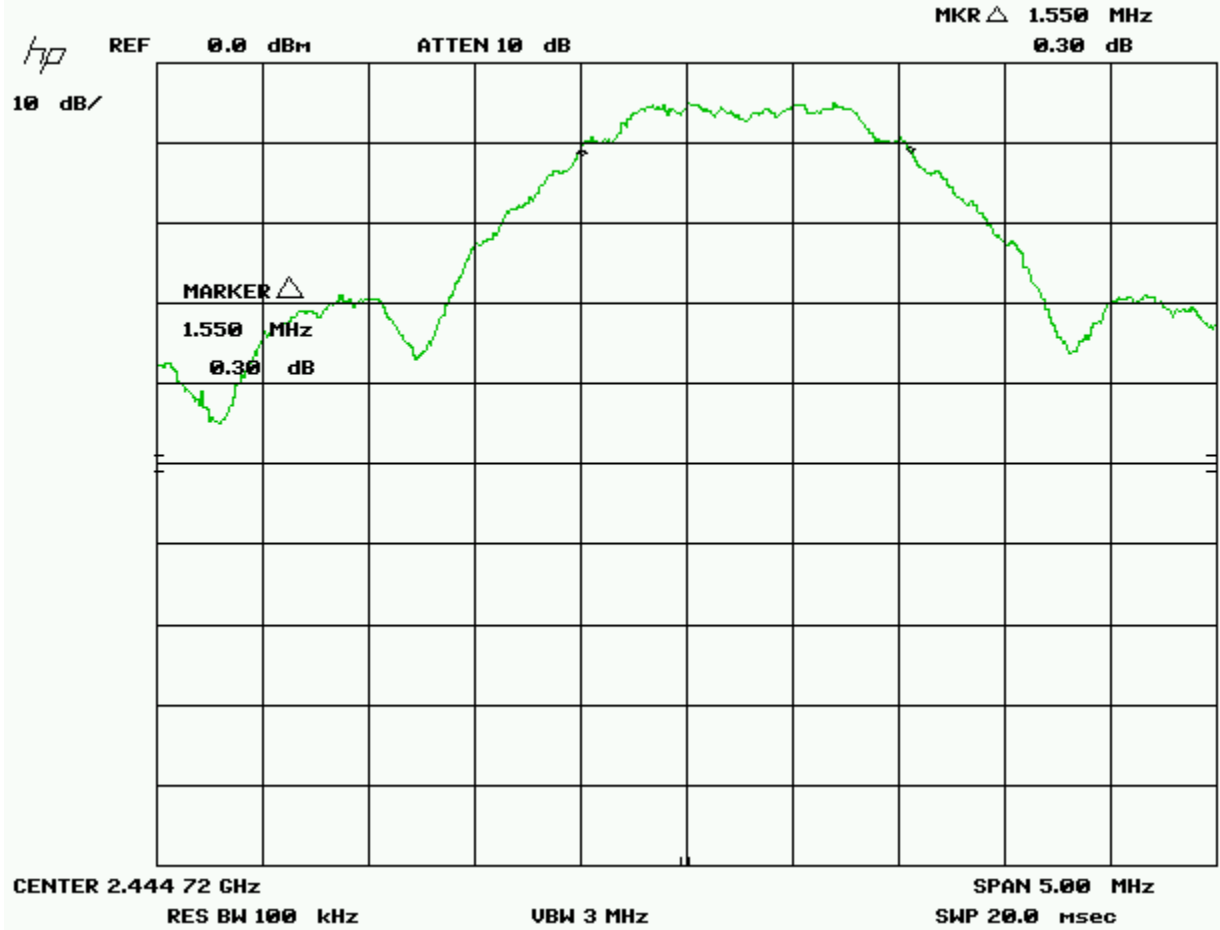

Client	MMB Research	
Product	RapidSE Zigbee Smart Energy Module ZGB.MMB-PA-LNA.1.0 and ZGB.MMB.-PA.1.0	
Standard(s)	RSS 210 Issue 6:2005 / FCC Part 15 Subpart C 15:2006	

High Channel

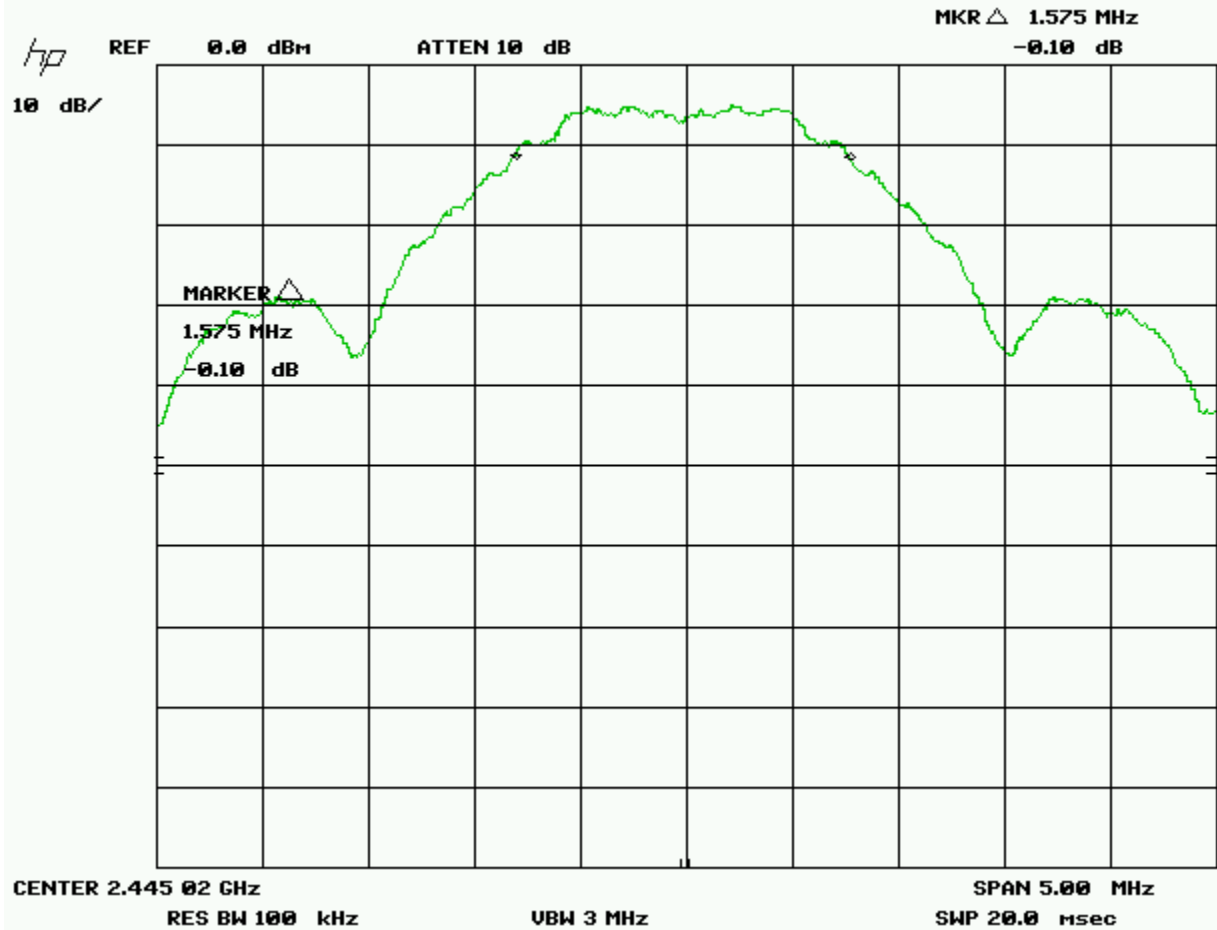

Note: See 'Appendix B – EUT & Test Setup Photographs' for photos showing the test set-up.

Client	MMB Research	
Product	RapidSE Zigbee Smart Energy Module ZGB.MMB-PA-LNA.1.0 and ZGB.MMB.-PA.1.0	
Standard(s)	RSS 210 Issue 6:2005 / FCC Part 15 Subpart C 15:2006	

Test Equipment List

Equipment	Model No.	Manufacturer	Last calibration date	Next calibration due date	Asset #
Attenuator 20 dB	FP-50-20	Trilithic	NCR	NCR	GEMC 43
Spectrum Analyzer	8566B	HP	2008-02-28	2010-02-28	GEMC 6
RF Cable 0.5M	LMR-400-0.5M-50OHM-MN-MN	LexTec	NCR	NCR	GEMC 31
RF Cable 1m	LMR-400-1M-50OHM-MN-MN	LexTec	NCR	NCR	GEMC 29
Power Attenuator 20 dB	25-A-FFN-20	Bird / Hutton	NCR	NCR	GEMC 49

This report module is based on GEMC template "FCC – Power Line Conducted Emissions Class B_Rev1"

Client	MMB Research	
Product	RapidSE Zigbee Smart Energy Module ZGB.MMB-PA-LNA.1.0 and ZGB.MMB.-PA.1.0	
Standard(s)	RSS 210 Issue 6:2005 / FCC Part 15 Subpart C 15:2006	

Maximum Peak Envelope Conducted Power

Purpose

The purpose of this test is to ensure that the maximum power conducted to the radiating element does not exceed the limits specified. This ensures that if the end-user replaces the antenna, that the maximum power does not exceed an amount which may create an excessive power level.

Limits

The limits are defined in 15.247(b).

For systems using digital modulation in the 902-928 MHz, 2400-2483.5 MHz, and 5725-5850 MHz bands, the peak limit is 1 watt.

Results

The EUT passed. The peak power measured was 17.5 dBm (56.23 mW).

Client	MMB Research	
Product	RapidSE Zigbee Smart Energy Module ZGB.MMB-PA-LNA.1.0 and ZGB.MMB.-PA.1.0	
Standard(s)	RSS 210 Issue 6:2005 / FCC Part 15 Subpart C 15:2006	

Table(s)

The tables shown below shows the peak power output of the device during the antenna conducted measurement during transmit operation of the EUT. Note there was 20 dB of external attenuation taken during this measurement.

Low channel



Client	MMB Research	
Product	RapidSE Zigbee Smart Energy Module ZGB.MMB-PA-LNA.1.0 and ZGB.MMB.-PA.1.0	
Standard(s)	RSS 210 Issue 6:2005 / FCC Part 15 Subpart C 15:2006	

Medium channel



Client	MMB Research	
Product	RapidSE Zigbee Smart Energy Module ZGB.MMB-PA-LNA.1.0 and ZGB.MMB.-PA.1.0	
Standard(s)	RSS 210 Issue 6:2005 / FCC Part 15 Subpart C 15:2006	

High channel

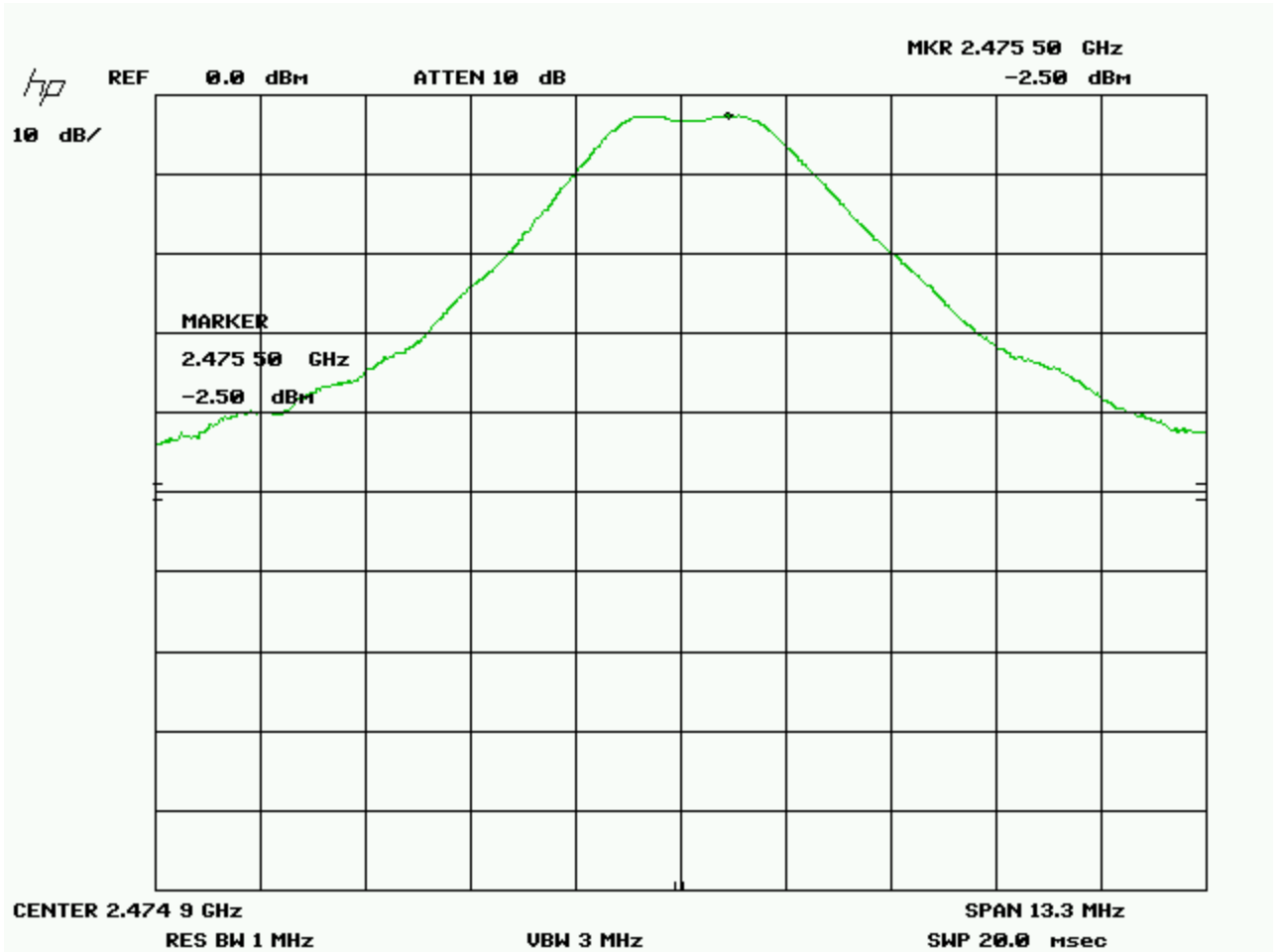

The calculated value is:
 $-2.5 \text{ dBm} + 20 \text{ dB (attenuator)}$
 $= 17.5 \text{ dbm}$

Note: See ‘Appendix B – EUT & Test Setup Photographs’ for photos showing the test set-up.

Client	MMB Research	
Product	RapidSE Zigbee Smart Energy Module ZGB.MMB-PA-LNA.1.0 and ZGB.MMB.-PA.1.0	
Standard(s)	RSS 210 Issue 6:2005 / FCC Part 15 Subpart C 15:2006	

Test Equipment List

Equipment	Model No.	Manufacturer	Last calibration date	Next calibration due date	Asset #
Spectrum Analyzer	8566B	HP	2008-02-28	2010-02-28	GEMC 6
Power meter	PM 2002	AR	2008-07-17	2010-07-19	GEMC 16
RF Cable 1m	LMR-400-1M-50OHM-MN-MN	LexTec	NCR	NCR	GEMC 29
Power Attenuator 20 dB	25-A-FFN-20	Bird / Hutton	NCR	NCR	GEMC 49

This report module is based on GEMC template "FCC – Power Line Conducted Emissions Class B_Rev1"

Client	MMB Research	
Product	RapidSE Zigbee Smart Energy Module ZGB.MMB-PA-LNA.1.0 and ZGB.MMB.-PA.1.0	
Standard(s)	RSS 210 Issue 6:2005 / FCC Part 15 Subpart C 15:2006	

Antenna Spurious Conducted Emissions (- 20 dbc Requirement)

Purpose

The purpose of this test is to ensure that the maximum power conducted to the radiating element at frequencies outside of the authorized spectrum does not exceed the limits specified. This ensures that the only the intended signal is delivered to the radiating element.

Limits

The limits are defined in 15.247(d). In any 100 kHz band, the peak spurious harmonics emissions must be at least 20 dB below the fundamental. Spurious Conducted emissions are to be evaluated up to the 10th harmonic. This -20 dBc requirement also applies at the 'band edge' or 2.4 GHz and 2.4835 GHz.

Results

The EUT passed the limits. Low, middle and high band was measured. The worst case for each mode is presented as a graph for the spectrum. The -20 dBc requirement is shown for the lower band edge at 2.4 GHz in the low band. The -20 dBc requirement is also shown for the higher band edge at 2.4835 GHz in the high band.

Graph(s)

The graphs shown below shows the peak power output of the device during the antenna conducted measurement during transmit operation of the EUT. Note there was 20 dB of external attenuation taken during this measurement.

Client	MMB Research	
Product	RapidSE Zigbee Smart Energy Module ZGB.MMB-PA-LNA.1.0 and ZGB.MMB.-PA.1.0	
Standard(s)	RSS 210 Issue 6:2005 / FCC Part 15 Subpart C 15:2006	

9 kHz – 2.5 GHz Lo

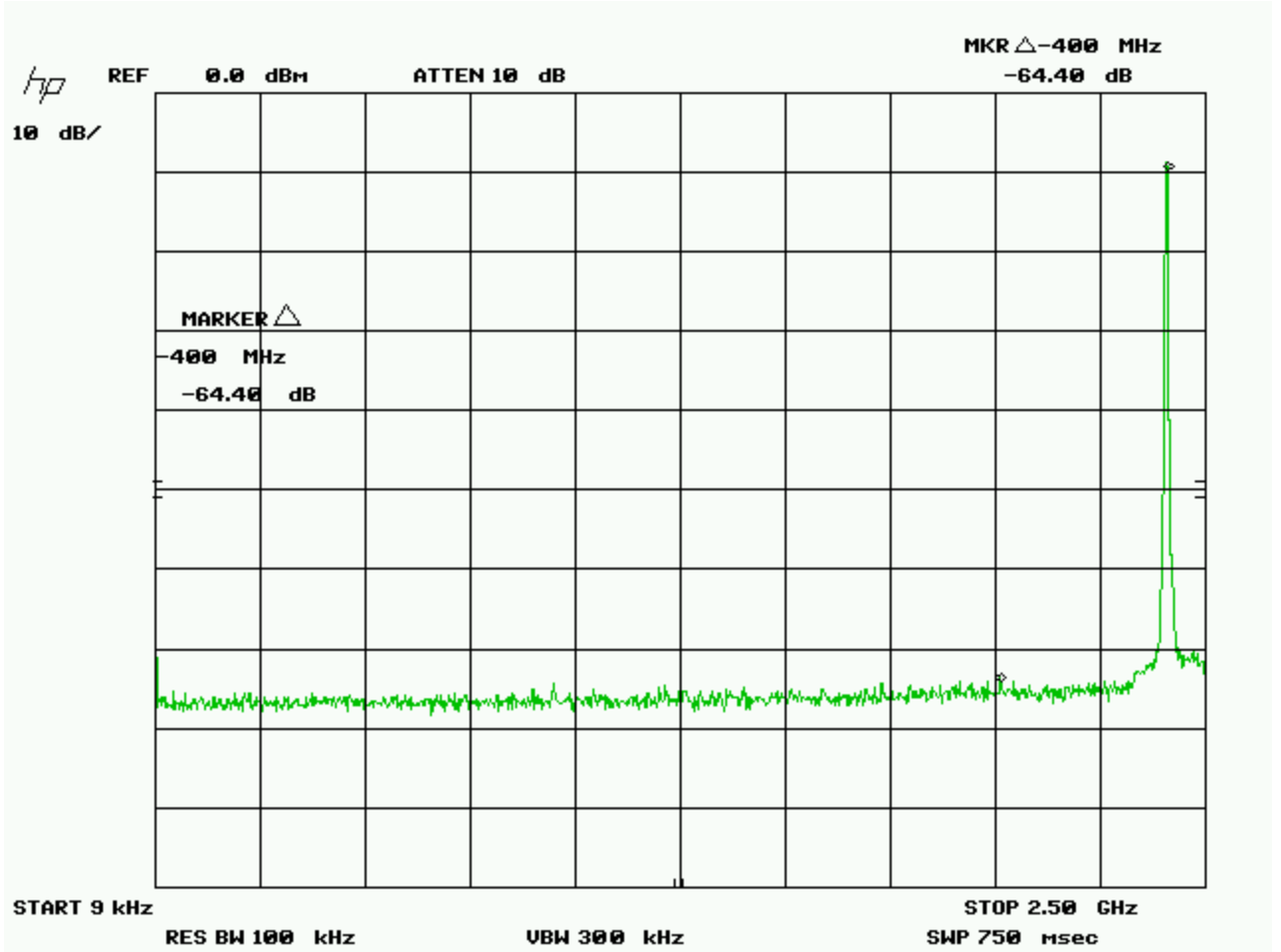

Client	MMB Research	
Product	RapidSE Zigbee Smart Energy Module ZGB.MMB-PA-LNA.1.0 and ZGB.MMB.-PA.1.0	
Standard(s)	RSS 210 Issue 6:2005 / FCC Part 15 Subpart C 15:2006	

9 kHz – 2.5 GHz Med

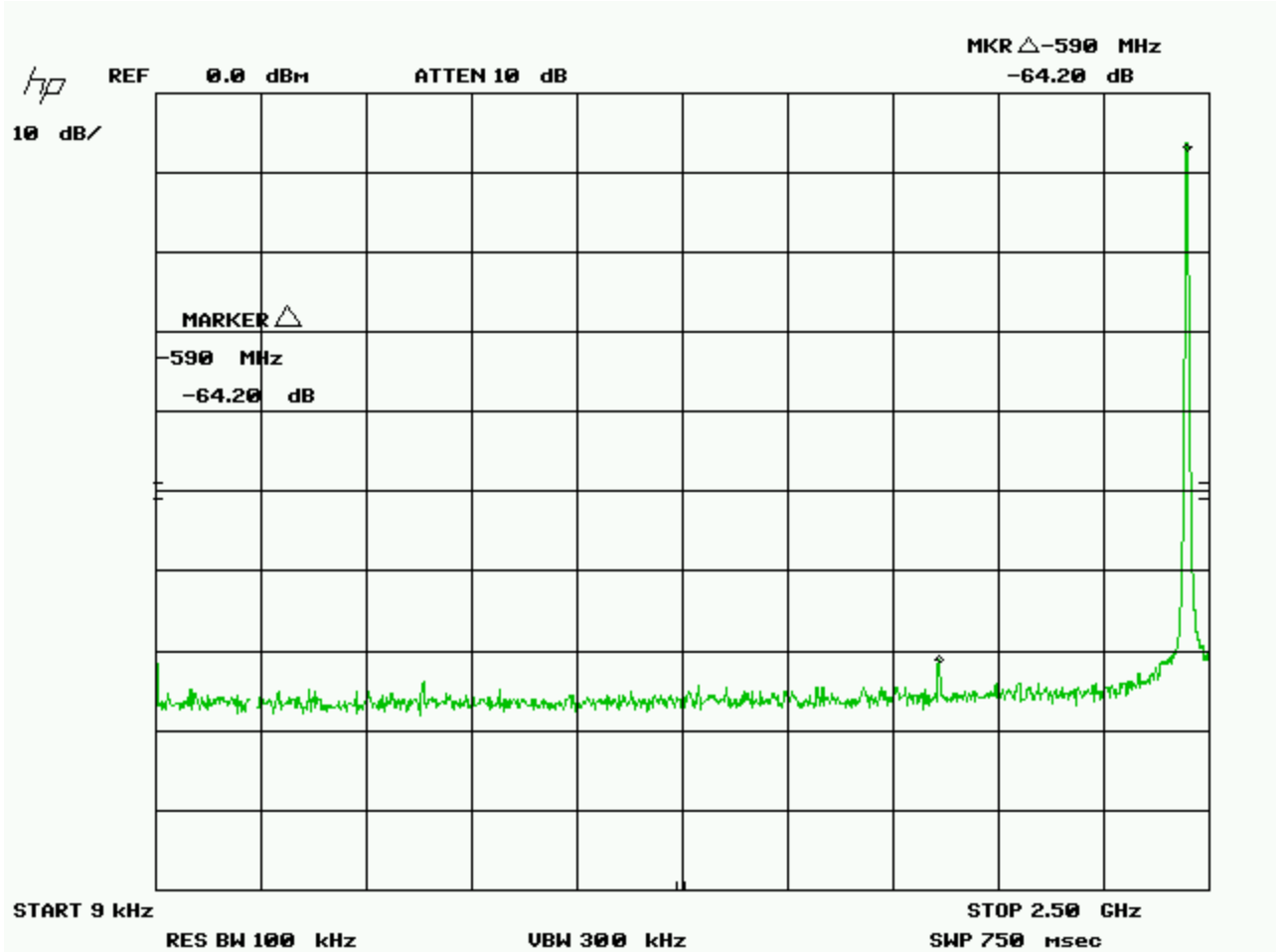

Client	MMB Research	
Product	RapidSE Zigbee Smart Energy Module ZGB.MMB-PA-LNA.1.0 and ZGB.MMB.-PA.1.0	
Standard(s)	RSS 210 Issue 6:2005 / FCC Part 15 Subpart C 15:2006	

9 kHz – 2.5 GHz Hi

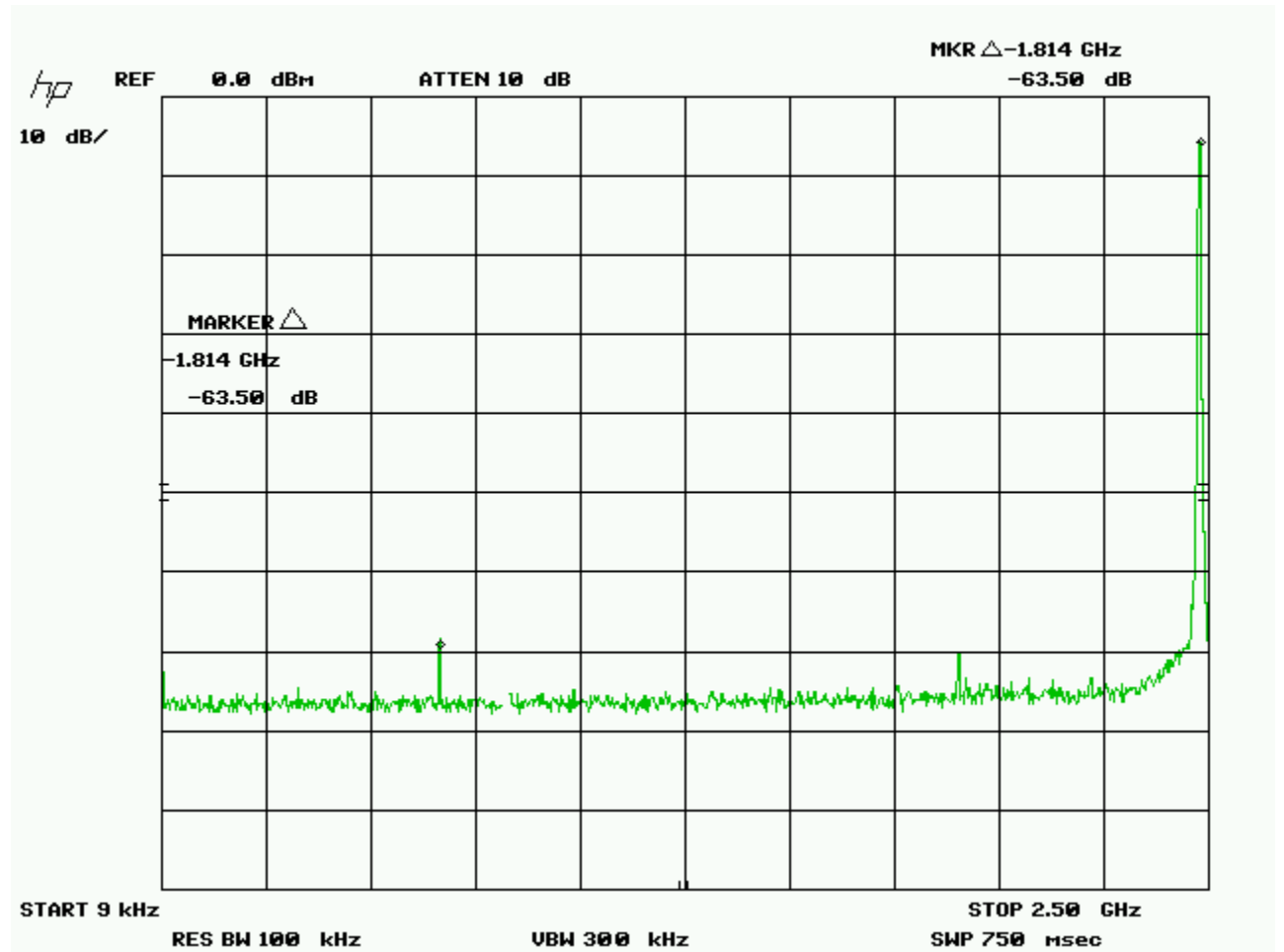

Client	MMB Research	
Product	RapidSE Zigbee Smart Energy Module ZGB.MMB-PA-LNA.1.0 and ZGB.MMB.-PA.1.0	
Standard(s)	RSS 210 Issue 6:2005 / FCC Part 15 Subpart C 15:2006	

2 GHz – 22.5 GHz Lo

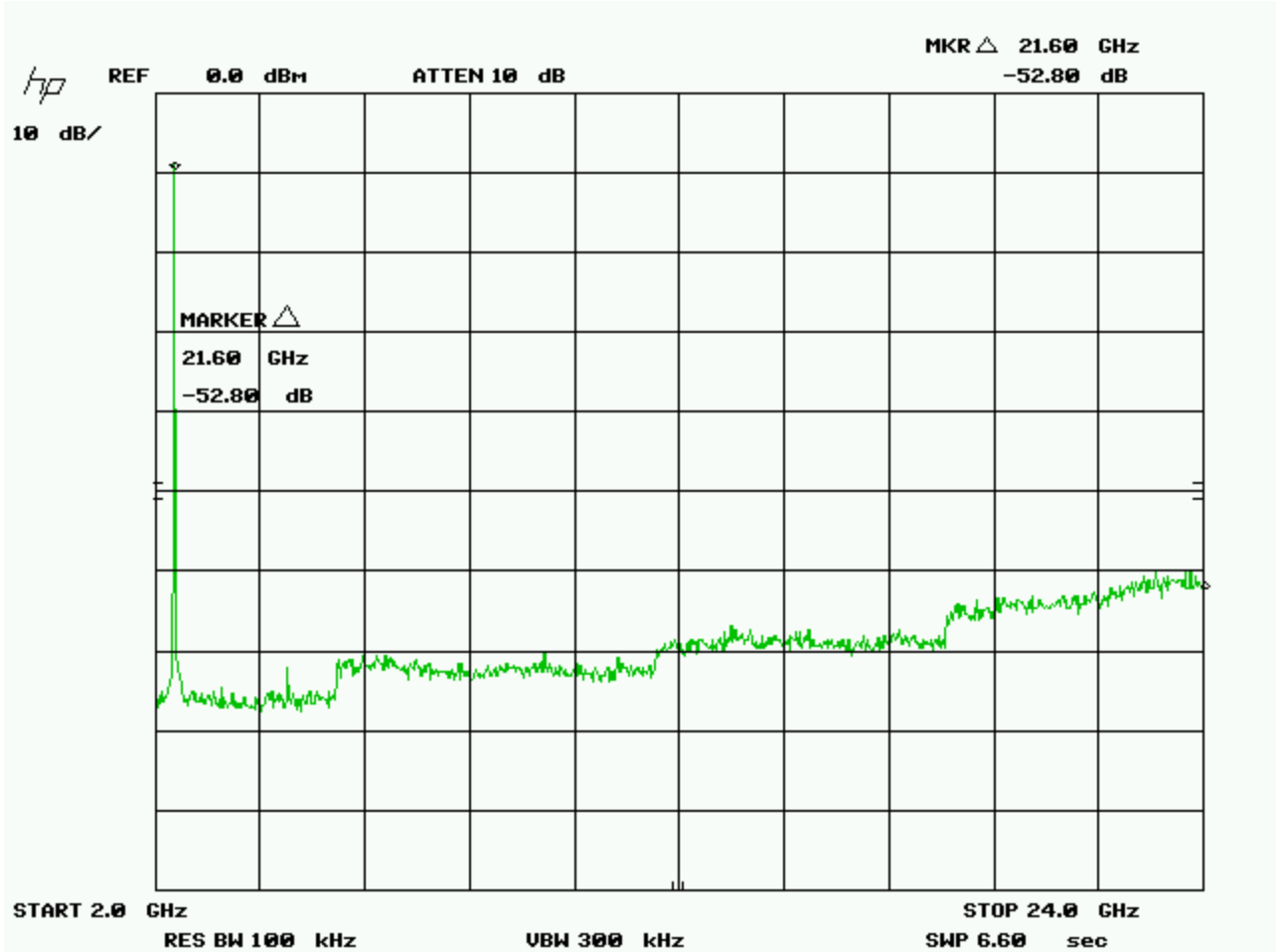

Client	MMB Research	
Product	RapidSE Zigbee Smart Energy Module ZGB.MMB-PA-LNA.1.0 and ZGB.MMB.-PA.1.0	
Standard(s)	RSS 210 Issue 6:2005 / FCC Part 15 Subpart C 15:2006	

2 GHz – 22.5 GHz Med

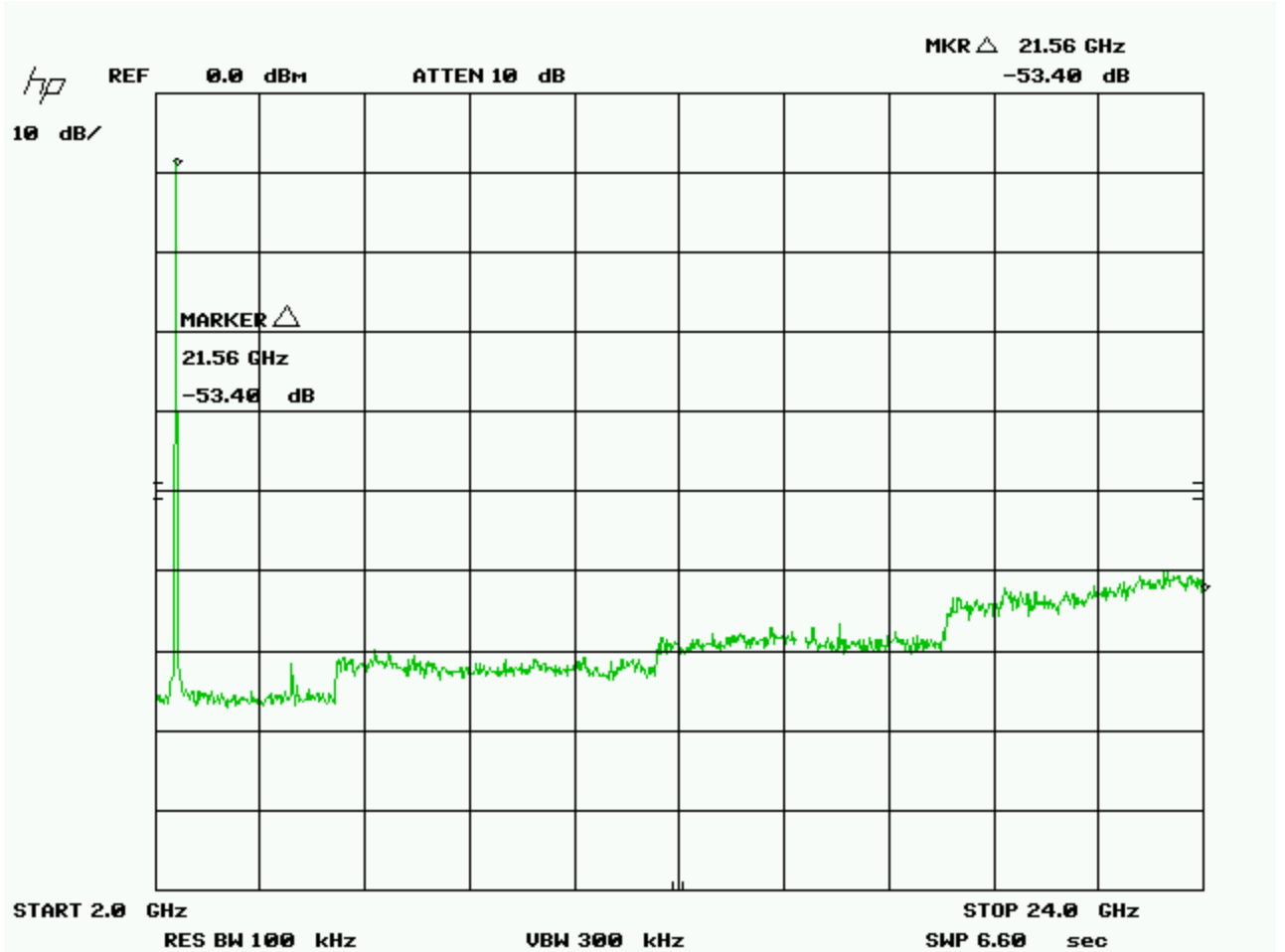

Client	MMB Research	
Product	RapidSE Zigbee Smart Energy Module ZGB.MMB-PA-LNA.1.0 and ZGB.MMB.-PA.1.0	
Standard(s)	RSS 210 Issue 6:2005 / FCC Part 15 Subpart C 15:2006	

2 GHz – 22.5 GHz Hi

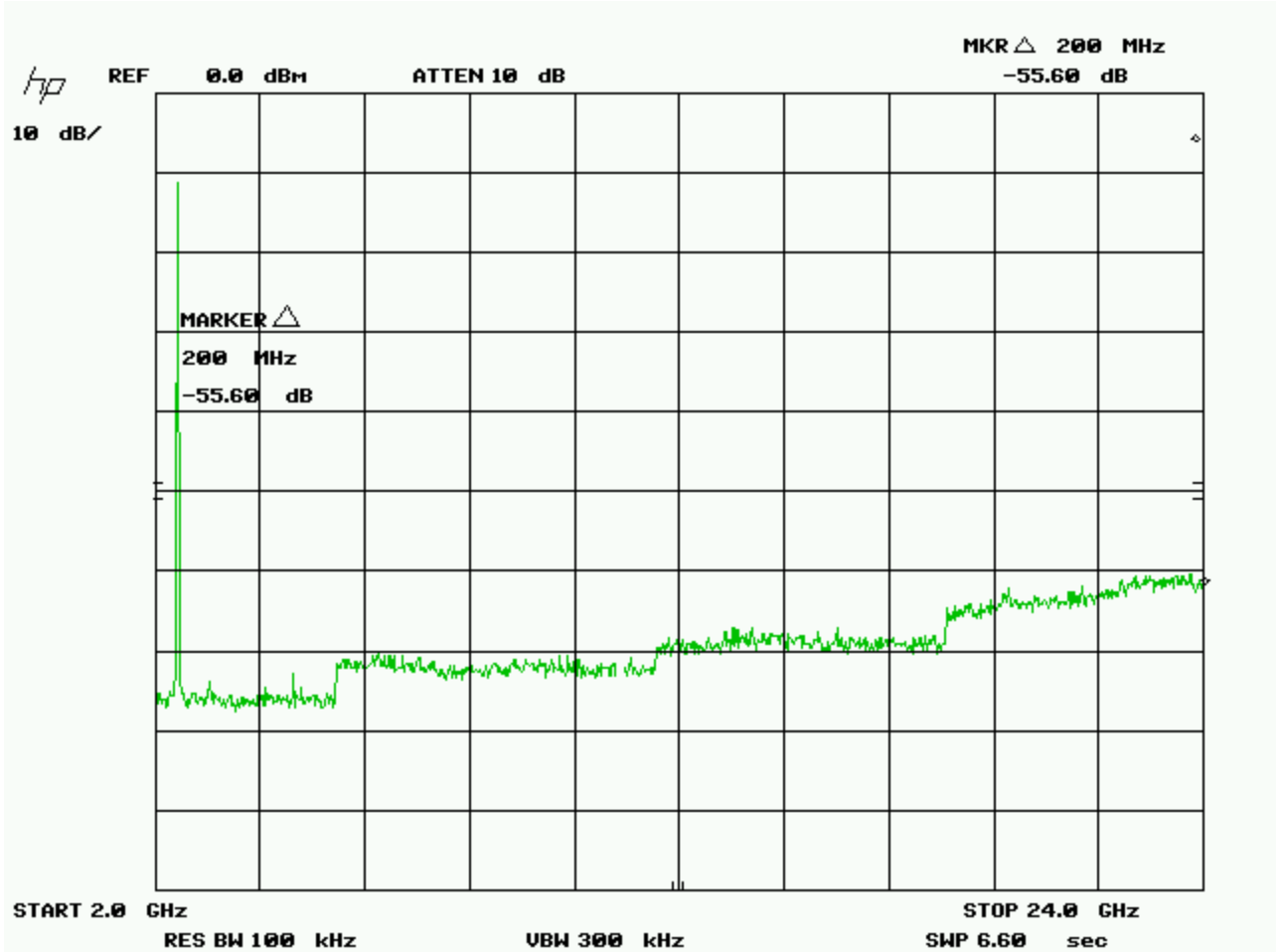

Client	MMB Research	
Product	RapidSE Zigbee Smart Energy Module ZGB.MMB-PA-LNA.1.0 and ZGB.MMB.-PA.1.0	
Standard(s)	RSS 210 Issue 6:2005 / FCC Part 15 Subpart C 15:2006	

2483.5 MHz Band edge
Vertical peak emissions

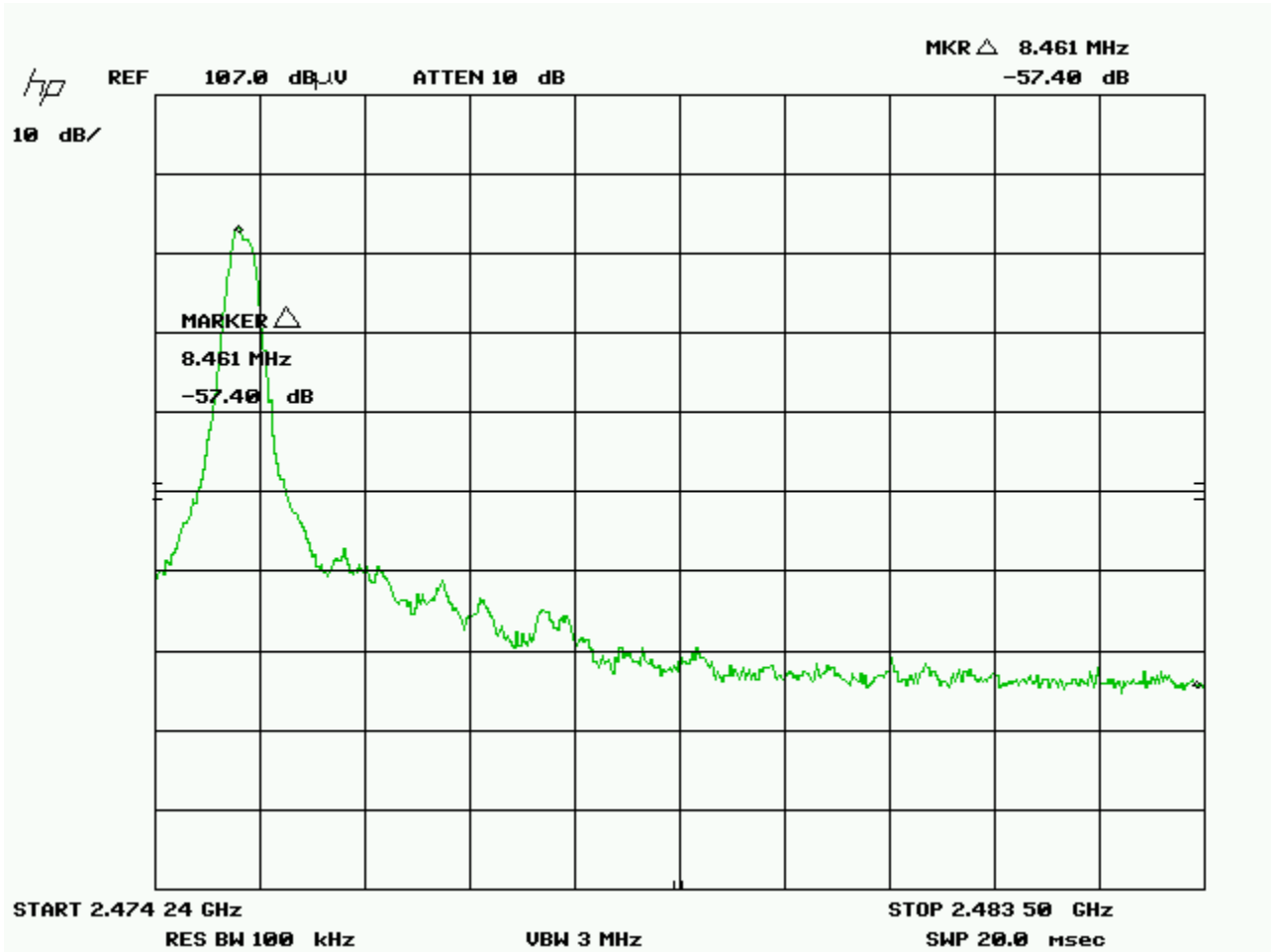

Client	MMB Research	
Product	RapidSE Zigbee Smart Energy Module ZGB.MMB-PA-LNA.1.0 and ZGB.MMB.-PA.1.0	
Standard(s)	RSS 210 Issue 6:2005 / FCC Part 15 Subpart C 15:2006	

2483.5 MHz Band edge
Horizontal peak emissions

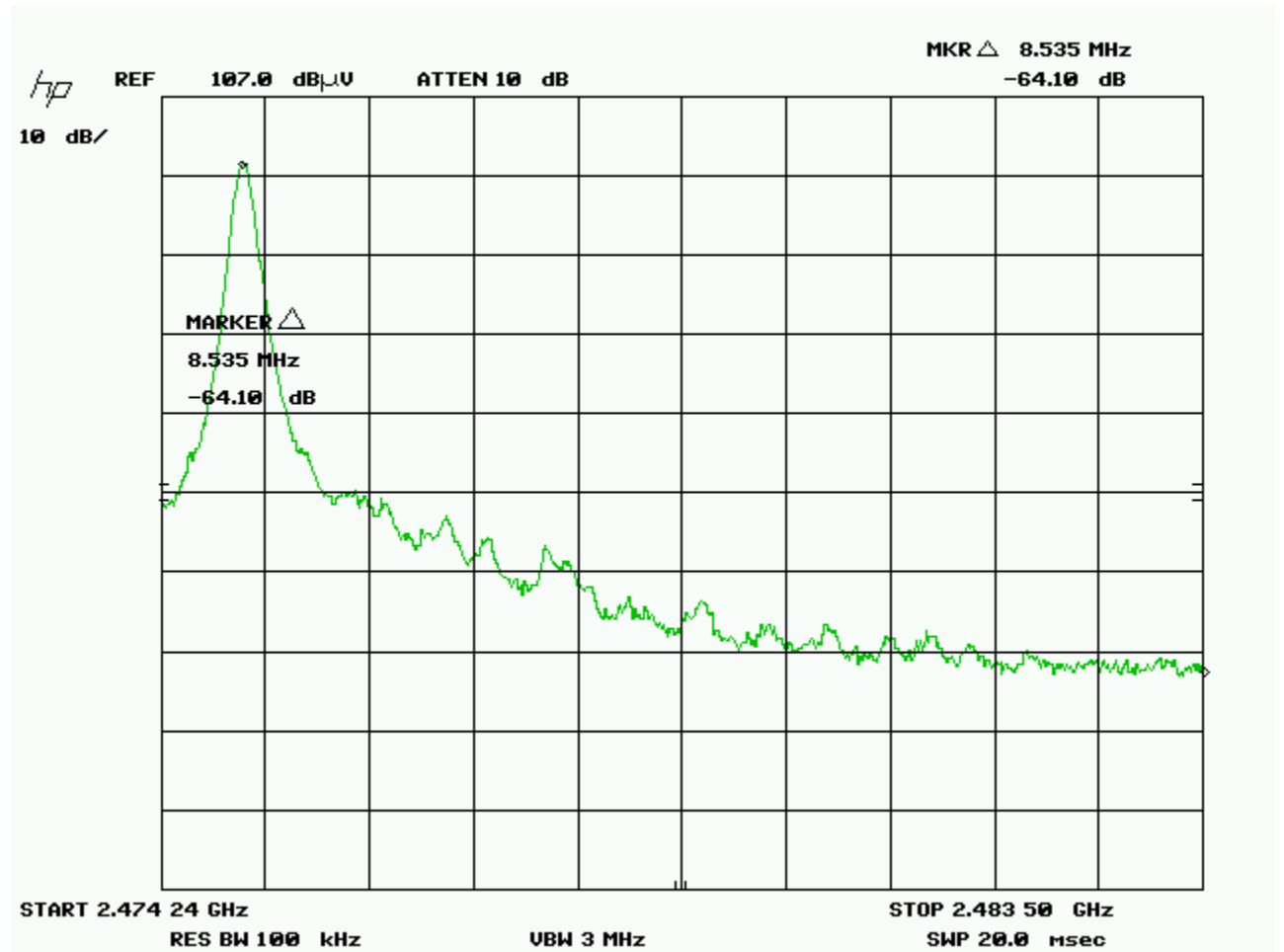

Client	MMB Research	
Product	RapidSE Zigbee Smart Energy Module ZGB.MMB-PA-LNA.1.0 and ZGB.MMB.-PA.1.0	
Standard(s)	RSS 210 Issue 6:2005 / FCC Part 15 Subpart C 15:2006	

2390 MHz Band edge
Vertical peak emissions

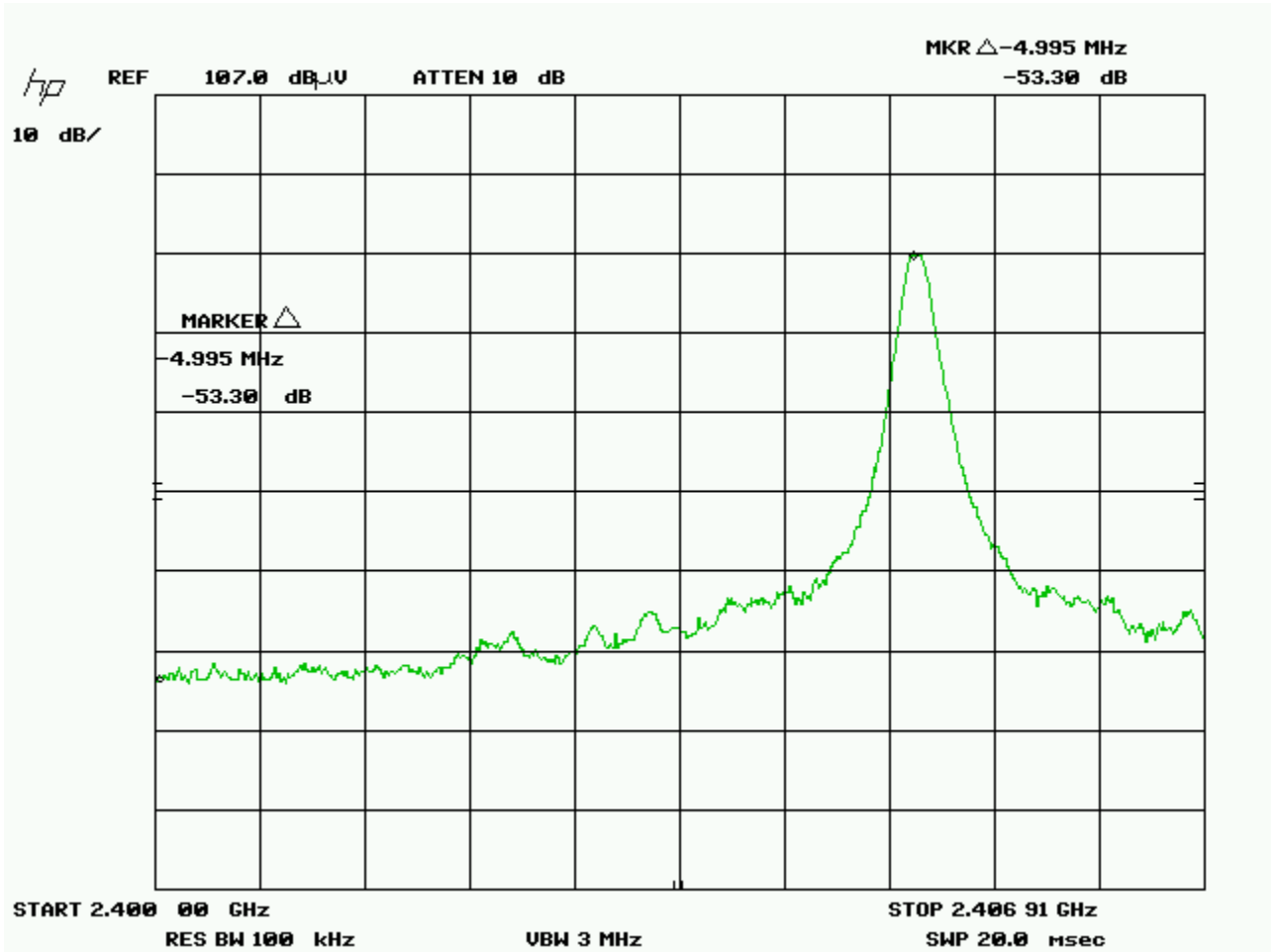

Client	MMB Research	
Product	RapidSE Zigbee Smart Energy Module ZGB.MMB-PA-LNA.1.0 and ZGB.MMB.-PA.1.0	
Standard(s)	RSS 210 Issue 6:2005 / FCC Part 15 Subpart C 15:2006	

2390 MHz Band edge
Horizontal peak emissions

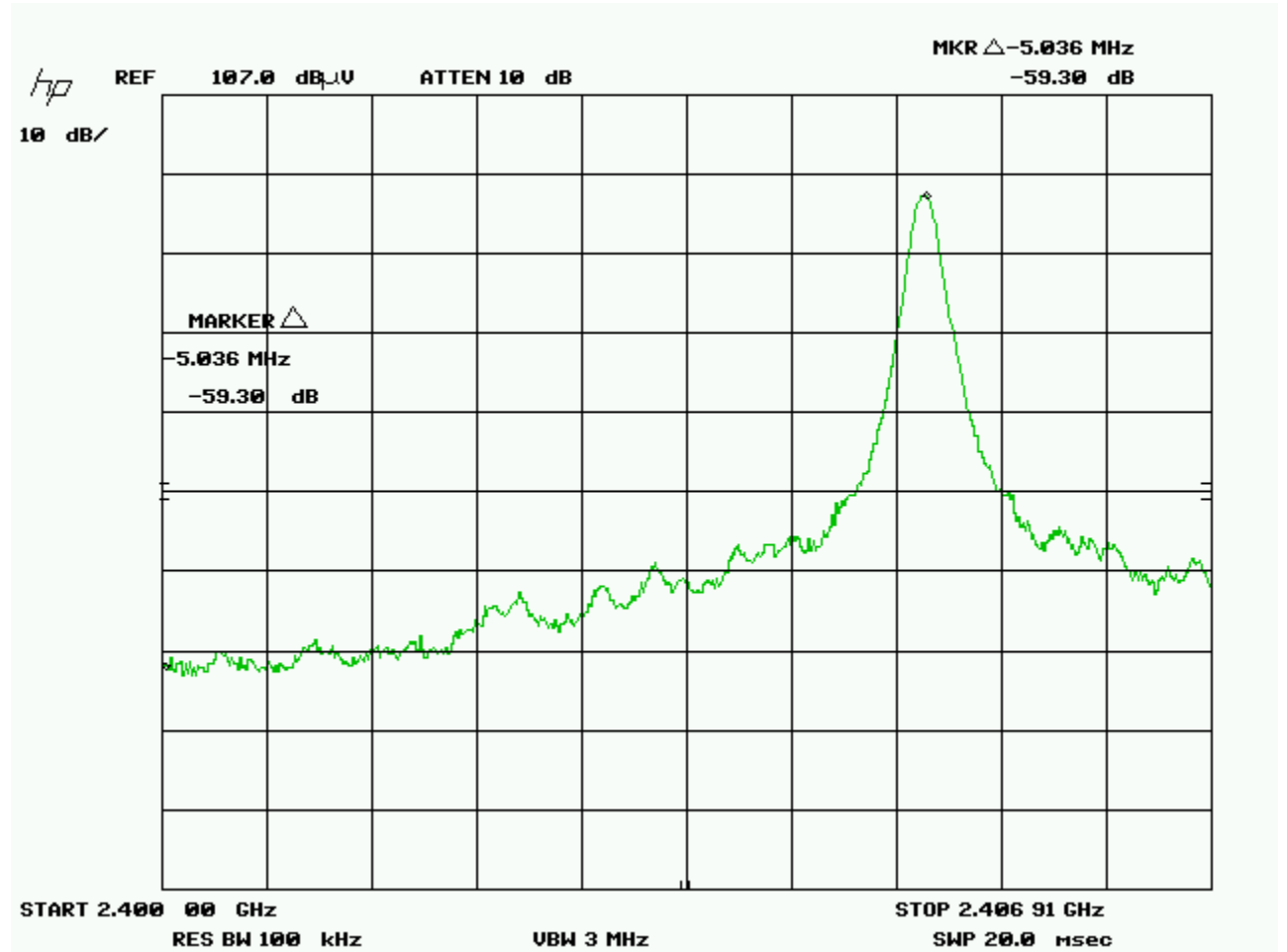

Client	MMB Research	
Product	RapidSE Zigbee Smart Energy Module ZGB.MMB-PA-LNA.1.0 and ZGB.MMB.-PA.1.0	
Standard(s)	RSS 210 Issue 6:2005 / FCC Part 15 Subpart C 15:2006	

The frequency range of 22.5 – 25 GHz, the 10th harmonic and 9th harmonic where applicable, was additionally scanned using an alternate spectrum analyzer, in low, middle and high band for each mode. No emissions were detected at the 9th and 10th harmonic.

The plots show raw data and no correction factors are applied. They simply show a 20dbc differential between the peak and the band edge

Note: See ‘Appendix B – EUT & Test Setup Photographs’ for photos showing the test set-up.

Test Equipment List

Equipment	Model No.	Manufacturer	Last calibration date	Next calibration due date	Asset #
Attenuator 1 dB	FP-50-1	Trilithic	NCR	NCR	GEMC 38
Attenuator 3 dB	FP-50-3	Trilithic	NCR	NCR	GEMC 40
Attenuator 6 dB	FP-50-6	Trilithic	NCR	NCR	GEMC 41
Attenuator 10 dB	FP-50-10	Trilithic	NCR	NCR	GEMC 42
Attenuator 20 dB	FP-50-20	Trilithic	NCR	NCR	GEMC 43
Spectrum Analyzer	8566B	HP	2008-02-28	2010-02-28	GEMC 6
Quasi Peak Adapter	85650A	HP	2008-02-28	2010-02-28	GEMC 7
RF Cable 1m	LMR-400-1M-50OHM-MN-MN	LexTec	NCR	NCR	GEMC 29
Power Attenuator 20 dB	25-A-FFN-20	Bird / Hutton	NCR	NCR	GEMC 49

This report module is based on GEMC template “FCC – Power Line Conducted Emissions Class B_Rev1”

Client	MMB Research	
Product	RapidSE Zigbee Smart Energy Module ZGB.MMB-PA-LNA.1.0 and ZGB.MMB.-PA.1.0	
Standard(s)	RSS 210 Issue 6:2005 / FCC Part 15 Subpart C 15:2006	

Power Spectral Density

Purpose

The purpose of this test is to ensure that the maximum power spectral density to the radiating element does not exceed the limits specified. This ensures that the modulation is significantly wide enough, or low enough in power that it will allow for co-operation of other wireless devices operating within this frequency allocation.

Limits

The limits are defined in 15.247(e).

For digitally modulated systems, the power spectral density conducted from the intentional radiator to the antenna shall not be greater than 8 dBm in any 3 kHz band during any time interval of continuous transmission.

Results

The EUT passed. Each mode was tested at low, medium, and high band. The worst case value is 1.4 dbm $\{-18.6 + 20 \text{ db (attenuator)} = 1.4 \text{ dbm}\}$.

Graph(s)

The graphs shown below show the power spectral density of the device during the conducted measurement operation of the EUT. Low, middle, and high channel was investigated in each mode.

Client	MMB Research	
Product	RapidSE Zigbee Smart Energy Module ZGB.MMB-PA-LNA.1.0 and ZGB.MMB.-PA.1.0	
Standard(s)	RSS 210 Issue 6:2005 / FCC Part 15 Subpart C 15:2006	

Low channel

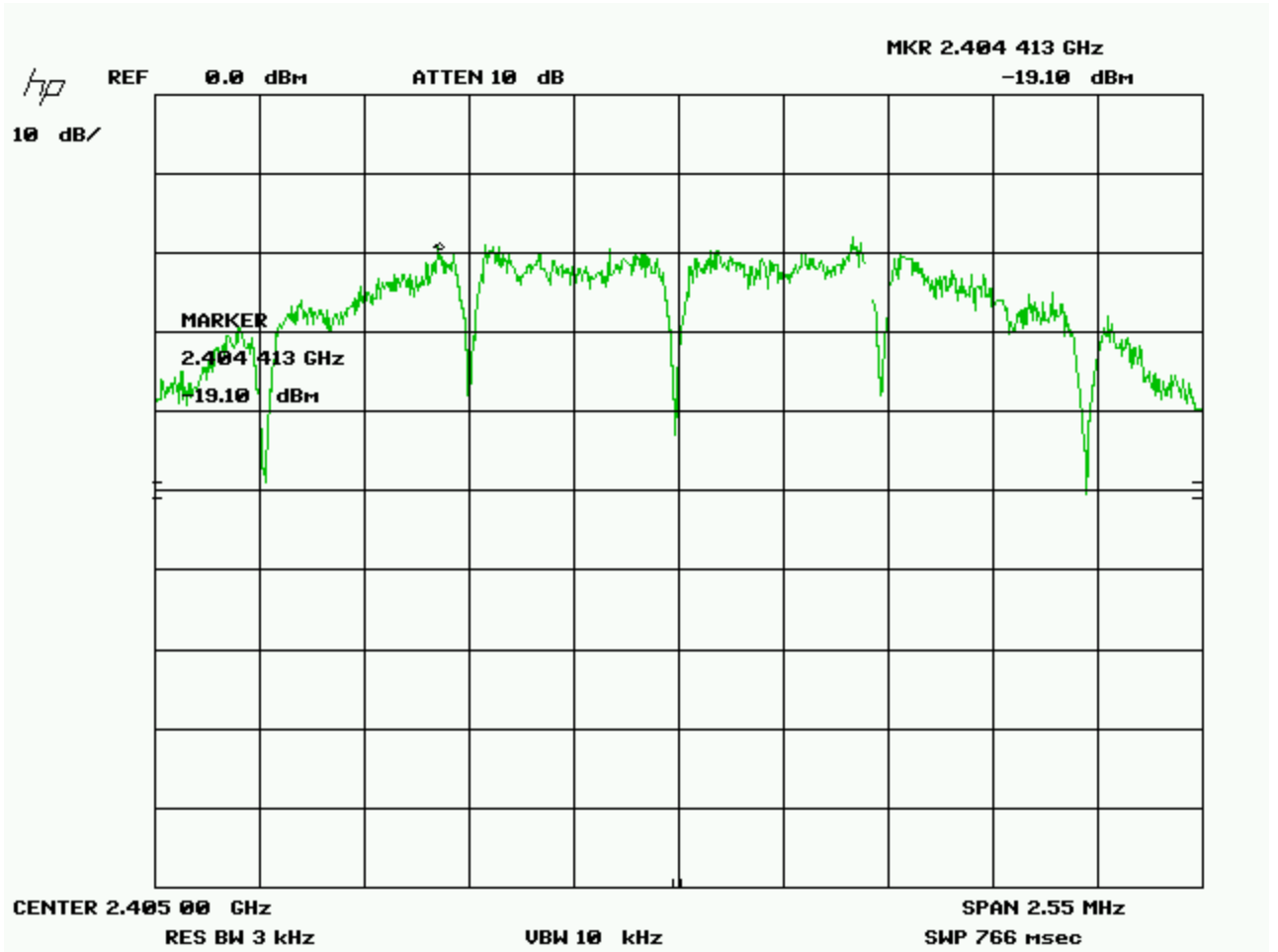

Client	MMB Research	
Product	RapidSE Zigbee Smart Energy Module ZGB.MMB-PA-LNA.1.0 and ZGB.MMB.-PA.1.0	
Standard(s)	RSS 210 Issue 6:2005 / FCC Part 15 Subpart C 15:2006	

Med channel

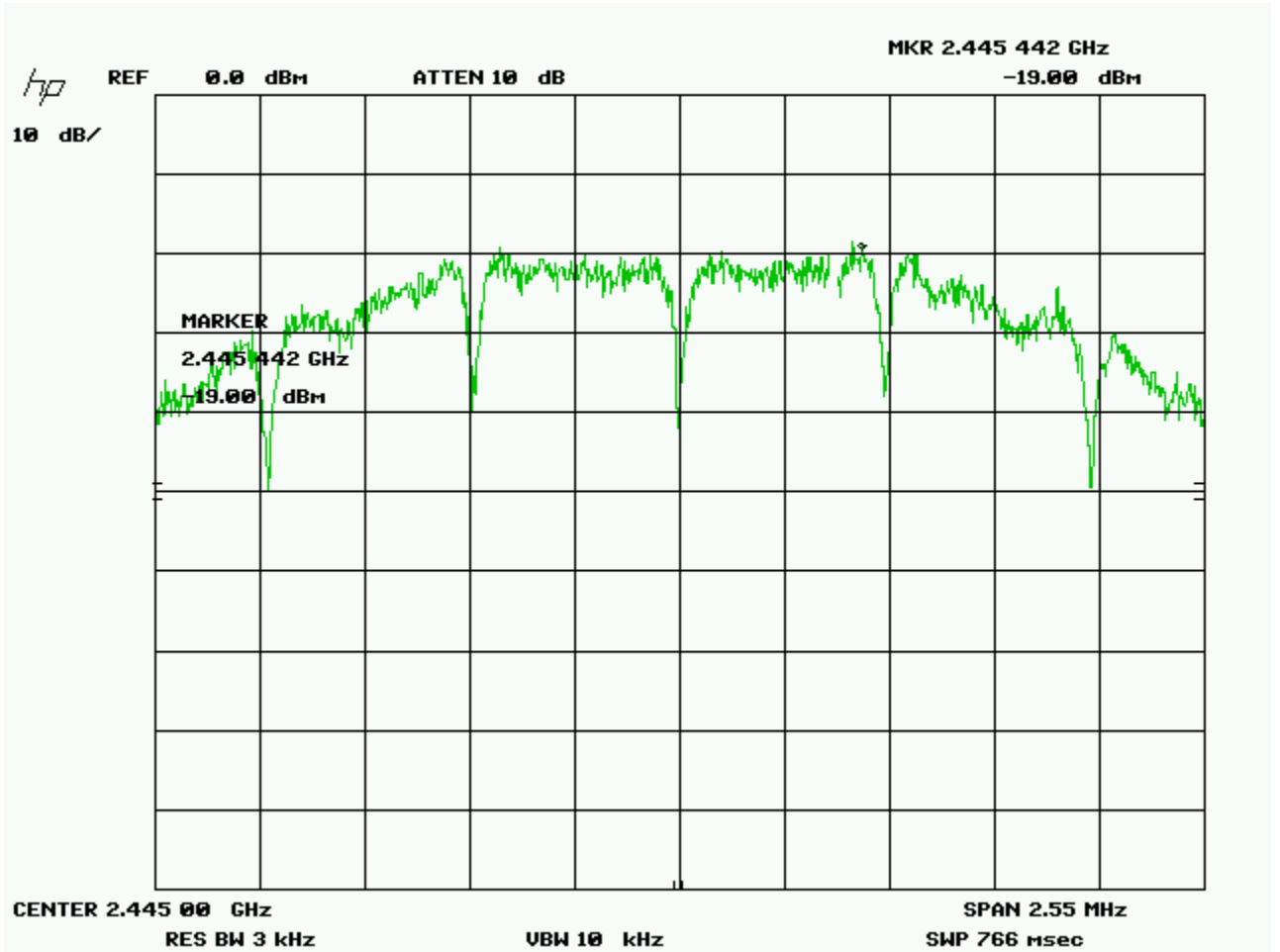

Client	MMB Research	
Product	RapidSE Zigbee Smart Energy Module ZGB.MMB-PA-LNA.1.0 and ZGB.MMB.-PA.1.0	
Standard(s)	RSS 210 Issue 6:2005 / FCC Part 15 Subpart C 15:2006	

High channel

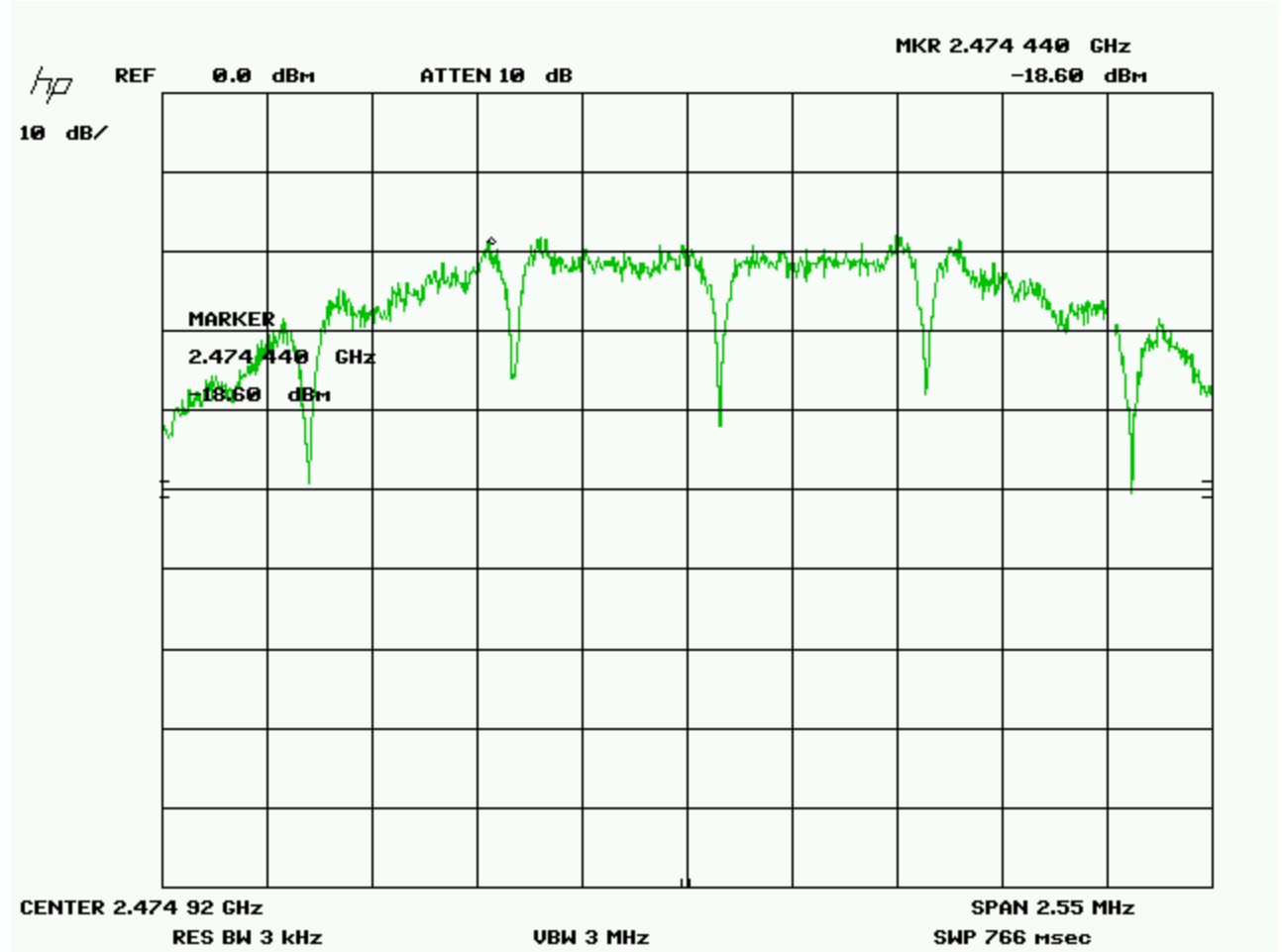

Note: See 'Appendix B – EUT & Test Setup Photographs' for photos showing the test set-up.

Client	MMB Research	
Product	RapidSE Zigbee Smart Energy Module ZGB.MMB-PA-LNA.1.0 and ZGB.MMB.-PA.1.0	
Standard(s)	RSS 210 Issue 6:2005 / FCC Part 15 Subpart C 15:2006	

Test Equipment List

Equipment	Model No.	Manufacturer	Last calibration date	Next calibration due date	Asset #
Spectrum Analyzer	8566B	HP	2008-02-28	2010-02-28	GEMC 6
RF Cable 1m	LMR-400-1M-50OHM-MN-MN	LexTec	NCR	NCR	GEMC 29
Power Attenuator 20 dB	25-A-FFN-20	Bird / Hutton	NCR	NCR	GEMC 49

This report module is based on GEMC template "FCC – Power Line Conducted Emissions Class B_Rev1"

Client	MMB Research	
Product	RapidSE Zigbee Smart Energy Module ZGB.MMB-PA-LNA.1.0 and ZGB.MMB.-PA.1.0	
Standard(s)	RSS 210 Issue 6:2005 / FCC Part 15 Subpart C 15:2006	

Maximum Permissible Exposure

Purpose

The purpose of this test is to ensure that the RF energy intentionally transmitted, in terms of power density emitted from the EUT at a stated operating distance does not exceed the limits listed below as defined in the applicable test standard, as calculated based upon readings obtained during testing. This helps protect human exposure to excessive RF fields.

Limit(s) and Method

The limits, as defined in FCC 15.247(i) and FCC 1.1310 Table 1 (B) limits for general public exposure was applied. The limit for the frequency range of 1.5 GHz to 100 GHz was applied. This is a limit of 1.0 mW/cm². The distance used for calculations was 20cm, as this is the minimum distance an operator will be from the EUT during normal operation, as stated by the manufacturer.

Results

The EUT passed the requirements. The worst case calculated power density was 0.022 mW/cm², this is significantly under the 1.0 mW/cm² requirement.

Calculations

Method 1 (conducted power)

$$P_d = (P_t * G) / (4 * \pi * R^2)$$

Where $P_t = 17.5$ dbm or 56.23mW as per Peak power conducted output

Where $G = 3.0$ dBi, or numerically 2.0

Where $R = 20$ cm

$$P_d = (56.23 \times 2.0) / (4 \times \pi \times 20\text{cm}^2)$$

$$P_d = 112.2 \text{ mW} / 5026 \text{ cm}^2$$

$$P_d = 0.022 \text{ mW/cm}^2$$

Client	MMB Research	
Product	RapidSE Zigbee Smart Energy Module ZGB.MMB-PA-LNA.1.0 and ZGB.MMB.-PA.1.0	
Standard(s)	RSS 210 Issue 6:2005 / FCC Part 15 Subpart C 15:2006	

Power Line Conducted Emissions

Purpose

The purpose of this test is to ensure that the RF energy unintentionally emitted from the EUT's power line does not exceed the limits listed below as defined in the applicable test standard, as measured from a LISN. This helps protect lower frequency radio services such as AM radio, shortwave radio, amateur radio operators, maritime radio, CB radio, and so on, from unwanted interference.

Limits & Method

The limits are as defined in 47 CFR FCC Part 15 Section 15.207

Method is as defined in ANSI C64:2003

Average Limits		QuasiPeak Limits	
150 kHz – 500 kHz	56 to 46 dBuV	150 kHz – 500 kHz	66 to 56 dBuV
500 kHz – 5 MHz	46 dBuV	500 kHz – 5 MHz	56 dBuV
5 MHz – 30 MHz	50 dBuV	500 kHz – 30 MHz	60 dBuV

The limit decreases linearly with the logarithm of the frequency in the range 0.15 MHz to 0.50 MHz.

Note: If the Peak or Quasi Peak detector measurements do not exceed the Average limits, then the EUT is deemed to have passed the requirements.

Both limits are applicable, and each is specified as being measured with a 9 kHz measurement bandwidth.

Client	MMB Research	
Product	RapidSE Zigbee Smart Energy Module ZGB.MMB-PA-LNA.1.0 and ZGB.MMB.-PA.1.0	
Standard(s)	RSS 210 Issue 6:2005 / FCC Part 15 Subpart C 15:2006	

Typical Setup Diagram

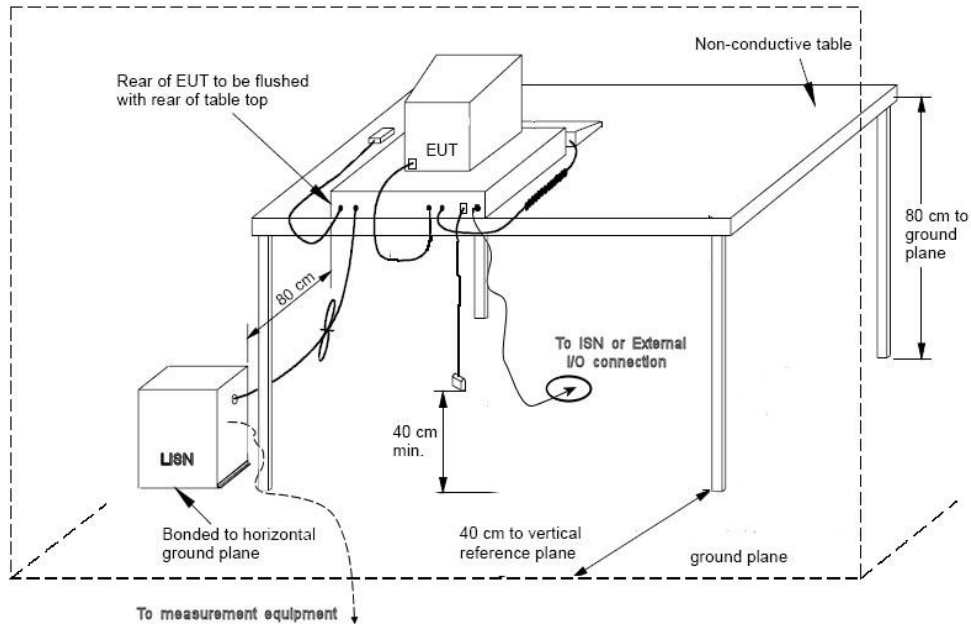

Note: The vertical reference plane is optional as per ANSI C63.4 section 5.2.2

Measurement Uncertainty

The expanded measurement uncertainty is calculated in accordance with CISPR 16-4-2 and is ± 3.6 dB with a 'k=2' coverage factor and a %95 confidence level.

Preliminary Graphs

Note the graphs shown below are for graphical illustration only. For final measurements with the appropriate detector where applicable, please refer to the table. The graph shown below is a peak measurement graph, measured with a resolution bandwidth greater than or equal to the final required detector. These graphs are performed as a worst case measurement to enable the detection of frequencies of concern and for considerable time savings.

Client	MMB Research	
Product	RapidSE Zigbee Smart Energy Module ZGB.MMB-PA-LNA.1.0 and ZGB.MMB.-PA.1.0	
Standard(s)	RSS 210 Issue 6:2005 / FCC Part 15 Subpart C 15:2006	

120V Line
Peak emissions

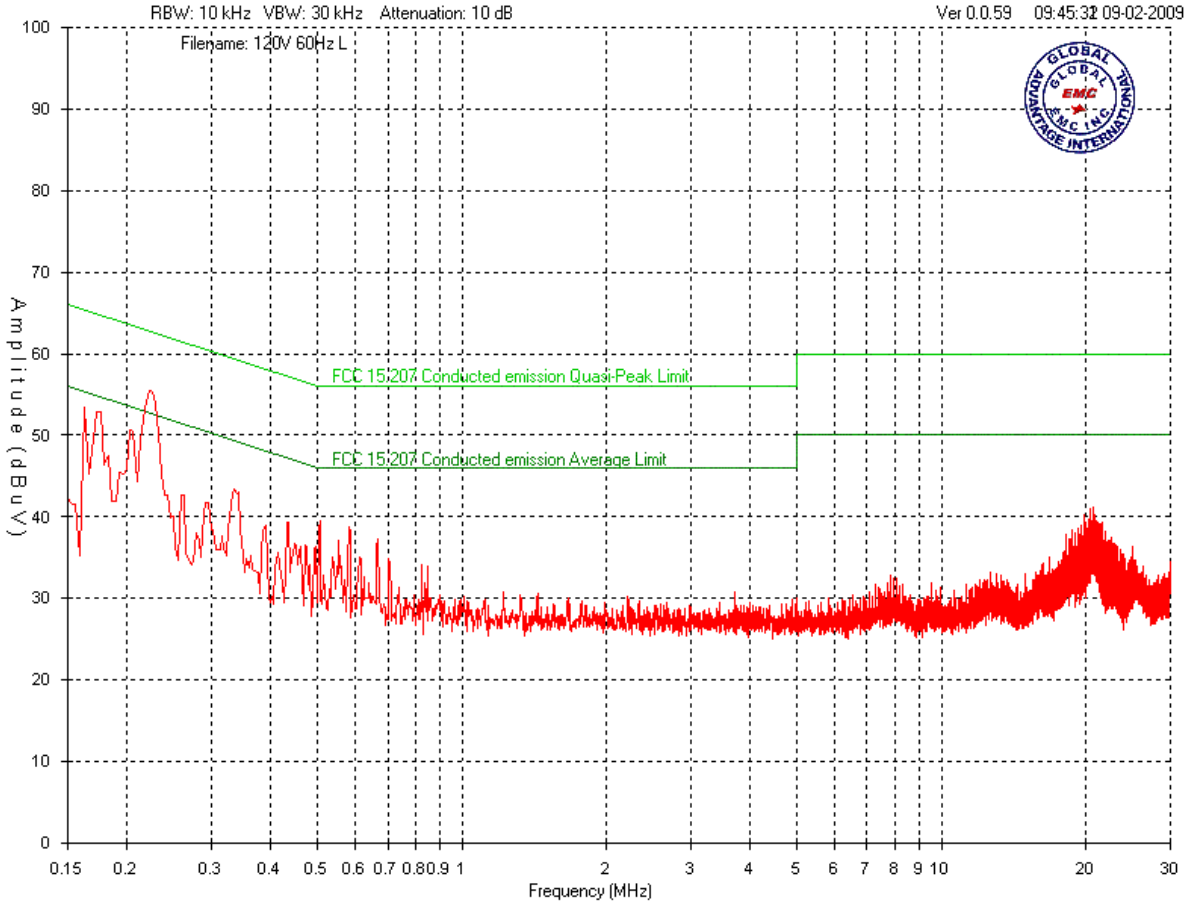

Client	MMB Research	
Product	RapidSE Zigbee Smart Energy Module ZGB.MMB-PA-LNA.1.0 and ZGB.MMB.-PA.1.0	
Standard(s)	RSS 210 Issue 6:2005 / FCC Part 15 Subpart C 15:2006	

120V Neutral Peak emissions

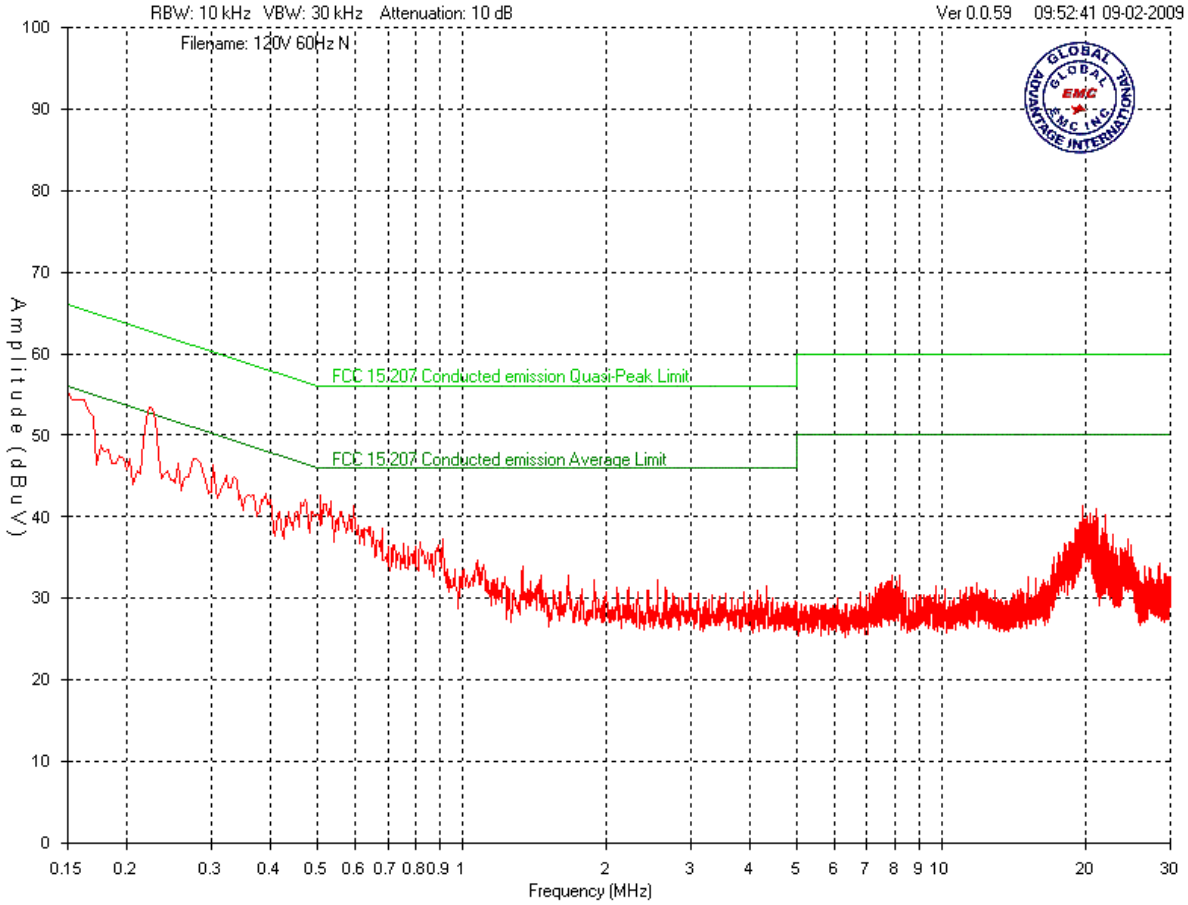

Client	MMB Research	
Product	RapidSE Zigbee Smart Energy Module ZGB.MMB-PA-LNA.1.0 and ZGB.MMB.-PA.1.0	
Standard(s)	RSS 210 Issue 6:2005 / FCC Part 15 Subpart C 15:2006	

Final Measurements

Average Emissions Table

Product category	Class B Avg								
Project	Wireless module								
Test Frequency (MHz)	Detection mode (Q-Peak / Avg)	Raw signal (dBuV)	Cable loss (dB)	Attenuator (dB)	LISN factor (dB)	Received signal (dBuV)	Emission limit (dBuV)	Margin (dBuV)	Result
120V 60Hz L									
0.22	QP	40.2	0.2	10	0.03	50.43	54	3.57	PASS
0.15	QP	31.2	0.2	10	0.05	41.45	56	14.55	PASS
0.33	QP	28.3	0.2	10	0.03	38.53	51	12.47	PASS
120V 60Hz N									
0.22	QP	40.5	0.2	10	0.03	50.73	54	3.27	PASS
0.15	QP	32.3	0.2	10	0.05	42.55	56	13.45	PASS
0.33	QP	29.5	0.2	10	0.03	39.73	51	11.27	PASS

Note:

1. All readings were recorded using QP detector and compared against Average limits.
2. See 'Appendix B – EUT & Test Setup Photographs' for photos showing the test set-up for the highest line conducted emission

Client	MMB Research	
Product	RapidSE Zigbee Smart Energy Module ZGB.MMB-PA-LNA.1.0 and ZGB.MMB.-PA.1.0	
Standard(s)	RSS 210 Issue 6:2005 / FCC Part 15 Subpart C 15:2006	

Test Equipment List

Equipment	Model No.	Manufacturer	Last calibration date	Next calibration due date	Asset #
Spectrum Analyzer	8566B	HP	2008-02-28	2010-02-28	GEMC 6
Quasi Peak Adapter	85650A	HP	2008-02-28	2010-02-28	GEMC 7
LISN	FCC-LISN-50/250-16-2-01	FCC	2009-02-11	2011-02-11	GEMC 65
RF Cable 7m	LMR-400-7M-50OHM-MN-MN	LexTec	NCR	NCR	GEMC 28
RF Cable 1m	LMR-400-1M-50OHM-MN-MN	LexTec	NCR	NCR	GEMC 29
Attenuator 10 dB	FP-50-10	Trilithic	NCR	NCR	GEMC 42

This report module is based on GEMC template "FCC – Power Line Conducted Emissions Class B_Rev1"

Client	MMB Research	
Product	RapidSE Zigbee Smart Energy Module ZGB.MMB-PA-LNA.1.0 and ZGB.MMB.-PA.1.0	
Standard(s)	RSS 210 Issue 6:2005 / FCC Part 15 Subpart C 15:2006	

Appendix A – EUT Summary

General EUT Description

Client	
Organization	MMB Research Inc.
Contact	Mark Borins
Phone	416.636.3145
Email	mark.borins@mmbresearch.com
EUT Details	
EUT Model number	ZGB.MMB-PA-LNA.1.0 and ZGB.MMB.-PA.1.0
Equipment Category	Wireless module for energy management applications.
Basic EUT Functionality	RapidSE™ is an embedded software package preloaded onto a ZigBee module. Integrated with your hardware, RapidSE acts as a gateway between your device and the local HAN. RapidSE maps ZigBee Smart Energy and Home Automation functions to a simple serial protocol, allowing you to issue and receive commands using your existing microcontroller.
Input Voltage and Frequency	5 Vdc
Connectors available on EUT	None.
Peripherals Required for Test	None.
Release type	Final
Intentional Radiator Frequency	2400 – 2480.0 MHz for Zigbee applications as described above.

Note the EUT is considered to have been received the date of the commencement of the first test, unless otherwise stated. For a close-up picture of the EUT, see ‘Appendix B – EUT & Test Setup Photographs’.

Client	MMB Research	
Product	RapidSE Zigbee Smart Energy Module ZGB.MMB-PA-LNA.1.0 and ZGB.MMB.-PA.1.0	
Standard(s)	RSS 210 Issue 6:2005 / FCC Part 15 Subpart C 15:2006	

Appendix B – EUT and Test Setup Photographs

Client	MMB Research	
Product	RapidSE Zigbee Smart Energy Module ZGB.MMB-PA-LNA.1.0 and ZGB.MMB.-PA.1.0	
Standard(s)	RSS 210 Issue 6:2005 / FCC Part 15 Subpart C 15:2006	

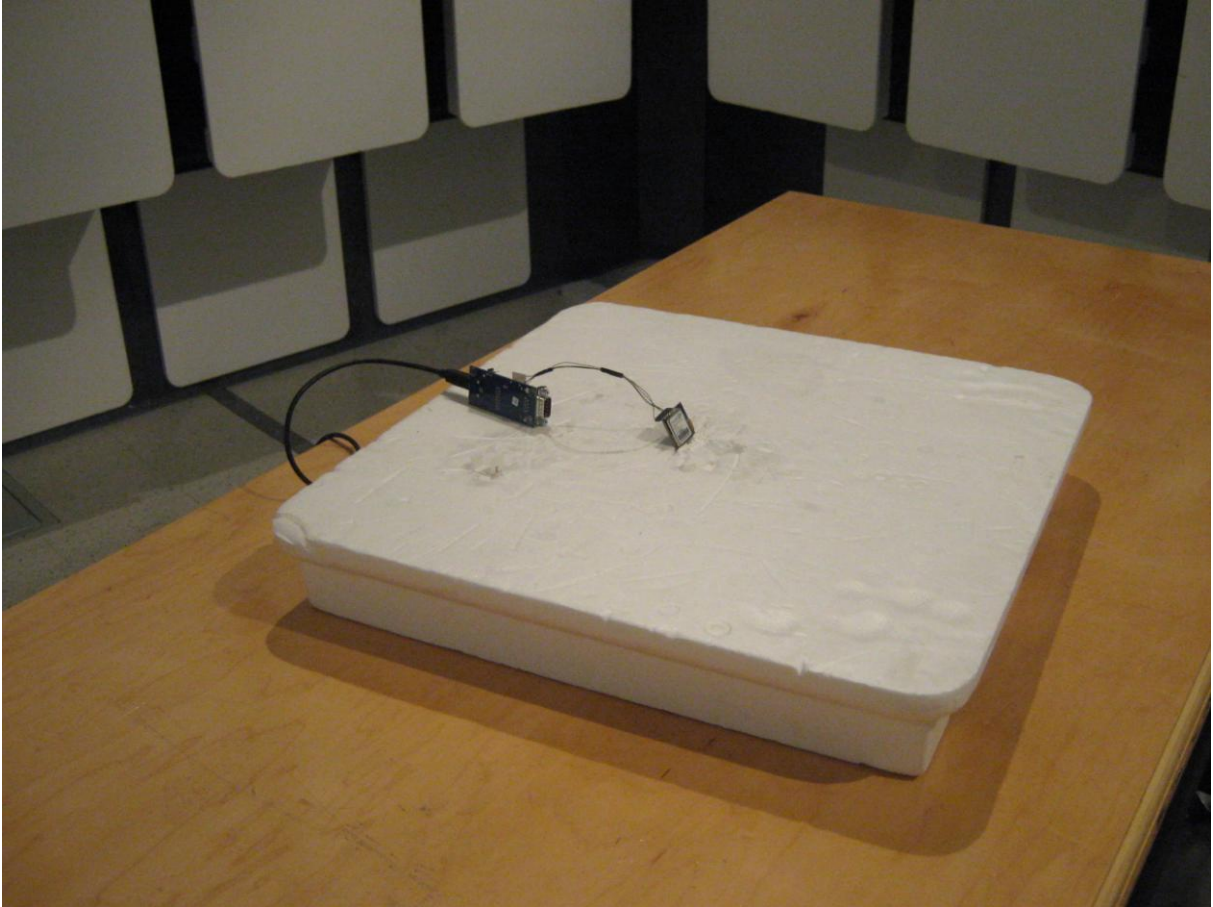



Figure 1 – EUT

Client	MMB Research	
Product	RapidSE Zigbee Smart Energy Module ZGB.MMB-PA-LNA.1.0 and ZGB.MMB.-PA.1.0	
Standard(s)	RSS 210 Issue 6:2005 / FCC Part 15 Subpart C 15:2006	

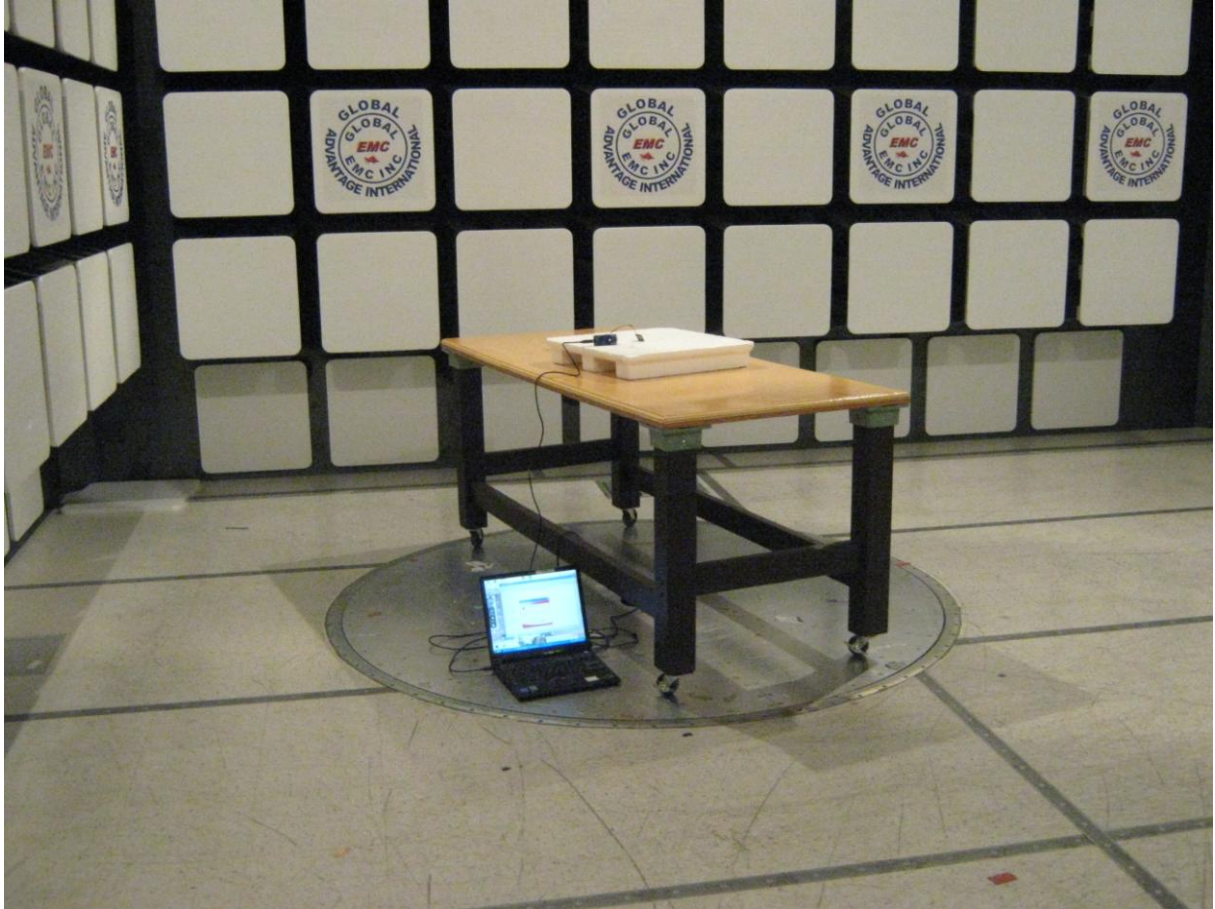

Figure 2 – Radiated emission setup

Client	MMB Research	
Product	RapidSE Zigbee Smart Energy Module ZGB.MMB-PA-LNA.1.0 and ZGB.MMB.-PA.1.0	
Standard(s)	RSS 210 Issue 6:2005 / FCC Part 15 Subpart C 15:2006	



Figure 3 – Power line conducted emissions

Client	MMB Research	
Product	RapidSE Zigbee Smart Energy Module ZGB.MMB-PA-LNA.1.0 and ZGB.MMB.-PA.1.0	
Standard(s)	RSS 210 Issue 6:2005 / FCC Part 15 Subpart C 15:2006	



Figure 4 – Conducted power emissions

Note: These photos are for information purposes only. Also refer to PDF files that are separate from this test report.