

RF Test Report

Applicant : Redpine Signals, Inc
Product Type : Single Band 802.11 b/g/n, Bluetooth 5.0, ZigBee Module
Trade Name : Redpine Signals Inc
Model Number : M15SB
Applicable Standard : FCC 47 CFR PART 15 SUBPART C
ANSI C63.10:2013
Receive Date : Oct. 24, 2018
Test Period : Nov. 06 ~ Nov. 25, 2018
Issue Date : Dec. 17, 2018

Issue by

A Test Lab Techno Corp.
No. 140-1, Changan Street, Bade District,
Taoyuan City 33465, Taiwan (R.O.C)
Tel : +886-3-2710188 / Fax : +886-3-2710190



Taiwan Accreditation Foundation accreditation number: 1330

Test Firm MRA designation number: TW0010

Note: This report shall not be reproduced except in full, without the written approval of A Test Lab Techno Corp. This document may be altered or revised by A Test Lab Techno Corp. personnel only, and shall be noted in the revision section of the document. The client should not use it to claim product endorsement by TAF, or any government agencies. The test results in the report only apply to the tested sample.



Revision History

Rev.	Issue Date	Revisions	Revised By
00	Dec. 05, 2018	Initial Issue	Janet Chao
01	Dec. 17, 2018	Revised Report Information	Janet Chao

Verification of Compliance

Issued Date: Dec. 17, 2018

Applicant : Redpine Signals, Inc

Product Type : Single Band 802.11 b/g/n, Bluetooth 5.0, ZigBee Module

Trade Name : Redpine Signals Inc

Model Number : M15SB

FCC ID : XF6-M15SB

EUT Rated Voltage : DC 1.8 V 0.4 A / DC 3.3 V 0.4 A

Test Voltage : DC 3.3 V

Applicable Standard : FCC 47 CFR PART 15 SUBPART C
ANSI C63.10:2013

Test Result : Complied

Performing Lab. : A Test Lab Techno Corp.
No. 140-1, Changan Street, Bade District,
Taoyuan City 33465, Taiwan (R.O.C)
Tel : +886-3-2710188 / Fax : +886-3-2710190
Taiwan Accreditation Foundation accreditation number: 1330
<http://www.atl-lab.com.tw/e-index.htm>



A Test Lab Techno Corp. tested the above equipment in accordance with the requirements set forth in the above standards. All indications of Pass/Fail in this report are opinions expressed by A Test Lab Techno Corp. based on interpretations and/or observations of test results. The test results show that the equipment tested is capable of demonstrating compliance with the requirements as documented in this report.

Approved By : Fly Lu (Manager) (Fly Lu) Reviewed By : Eric Ou Yang (Testing Engineer) (Eric Ou Yang)



TABLE OF CONTENTS

1	General Information	5
2	EUT Description	7
3	Test Methodology	8
	3.1. Mode of Operation	8
	3.2. EUT Test Step	15
	3.3. Configuration of Test System Details	16
	3.4. Test Instruments	17
	3.5. Test Site Environment	17
4	Measurement Procedure	18
	4.1. Radiated Emission Measurement	18
	4.2. Maximum Conducted Output Power Measurement	23
	4.3. 6 dB RF Bandwidth Measurement	24
	4.4. Maximum Power Spectral Density Measurement.....	25
	4.5. Out of Band Conducted Emissions Measurement	26
	4.6. Antenna Measurement	27
5	Test Results	28
	Annex A. Conducted Test Results	28
	Annex B. Radiated Emission Test Results	76



1 General Information

1.1 Summary of Test Result

Standard	Item	Result	Remark
FCC			
15.207	AC Power Conducted Emission	N/A	The device uses DC power source.
15.247(d)	Transmitter Radiated Emissions	PASS	-----
15.247(b)(3)	Max. Output Power	PASS	-----
15.247(a)(2)	6 dB RF Bandwidth	PASS	-----
15.247(e)	Maximum Power Spectral Density	PASS	-----
15.247(d)	Out of Band Conducted Spurious Emission	PASS	-----
15.203	Antenna Requirement	PASS	-----

The test results of this report relate only to the tested sample(s) identified in this report.

Standard	Description
CFR47, Part 15, Subpart C	Intentional Radiators
ANSI C63. 10: 2013	American National Standard of Procedures for Compliance Testing of Unlicensed Wireless Devices
KDB 558074 D01 v05	GUIDANCE FOR COMPLIANCE MEASUREMENTS ON DIGITAL TRANSMISSION SYSTEM, FREQUENCY HOPPING SPREAD SPECTRUM SYSTEM, AND HYBRID SYSTEM DEVICES OPERATING UNDER SECTION 15.247 OF THE FCC RULES

1.2 Measurement Uncertainty

Test Item	Frequency Range	Uncertainty (dB)
Conducted Emission	9 kHz ~ 150 kHz	2.7
	150 kHz ~ 30 MHz	2.7
Radiated Emission	9 kHz ~ 30 MHz	1.7
	30 MHz ~ 1000 MHz	5.7
	1000 MHz ~ 18000 MHz	5.5
	18000 MHz ~ 26500 MHz	4.8
	26500 MHz ~ 40000 MHz	4.8
Conducted Output Power	+0.27 dB / -0.28 dB	
RF Bandwidth	4.96 %	
Power Spectral Density	+0.71 dB / -0.77 dB	



2 EUT Description

Applicant	Redpine Signals, Inc 2107 N.First Street, Suite 680, San Jose, California, 95131-2019, United States			
Manufacturer	Redpine Signals, Inc 2107 N.First Street, Suite 680, San Jose, California, 95131-2019, United States			
Product Type	Single Band 802.11 b/g/n, Bluetooth 5.0, ZigBee Module			
Trade Name	Redpine Signals Inc			
Model Number	M15SB			
FCC ID	XF6-M15SB			
Operate Freq. Band	Frequency Range (MHz)	Modulation	Channel Bandwidth	Data Rate 400 GI (ns)
IEEE 802.11b	2412 ~ 2462	DSSS	20 MHz	Up to 11 Mbps
IEEE 802.11g	2412 ~ 2462	OFDM	20 MHz	Up to 54 Mbps
IEEE 802.11n 2.4 GHz 20 MHz	2412 ~ 2462	OFDM	20 MHz	Up to 72.2 Mbps
IEEE 802.11n 2.4 GHz 40 MHz	2422 ~ 2452	OFDM	40 MHz	Up to 150 Mbps
Antenna information	Model	Type	Connector	Max. Gain (dBi)
	RSIA15	PCB Trace Antenna	Internal	0.99
	WS.01.B.305151	Heavy Duty Screw Mount Antenna	SMA Reverse	4.1
Antenna Delivery	See section 3.1			
Operate Temp. Range	-40 ~ +85 °C			

Frequency Band	Max. RF Output Power (W)
Power setting 1_Antenna Type: PCB Trace Antenna	
IEEE 802.11b	0.075
IEEE 802.11g	0.146
IEEE 802.11n 2.4 GHz 20 MHz	0.160
IEEE 802.11n 2.4 GHz 40 MHz	0.063
Power setting 2_Antenna Type: Heavy Duty Screw Mount Antenna	
IEEE 802.11b	0.068
IEEE 802.11g	0.146
IEEE 802.11n 2.4 GHz 20 MHz	0.160
IEEE 802.11n 2.4 GHz 40 MHz	0.030

3 Test Methodology

3.1. Mode of Operation

Decision of Test ATL has verified the construction and function in typical operation. All the test modes were carried out with the EUT in normal operation, which was shown in this test report and defined as:

Test Mode
Mode 1: Transmit mode
Mode 2: IEEE 802.11b Continuous TX mode
Mode 3: IEEE 802.11g Continuous TX mode
Mode 4: IEEE 802.11n 2.4 GHz 20 MHz Continuous TX mode
Mode 5: IEEE 802.11n 2.4 GHz 40 MHz Continuous TX mode

Software used to control the EUT for staying in continuous transmitting mode was programmed.

After verification, all tests were carried out with the worst case test modes.

By preliminary testing and verifying three axis (X, Y and Z) position of EUT transmitted status, it was found that "X axis" position was the worst, then the final test was executed the worst condition and test data were recorded in this report.

RF Power setting	Antenna Type	Antenna Max. Gain (dBi)	Test Mode	Antenna Delivery	Data Rate	Test Channel
1	PCB Trace Antenna	0.99	Mode 2	1TX	1 M	1, 6, 11
			Mode 3	1TX	6 M	1, 6, 11
			Mode 4	1TX	6.5 M	1, 6, 11
			Mode 5	1TX	13.5 M	3, 6, 9
2	Heavy Duty Screw Mount Antenna	4.1	Mode 2	1TX	1 M	1, 6, 11
			Mode 3	1TX	6 M	1, 6, 11
			Mode 4	1TX	6.5 M	1, 6, 11
			Mode 5	1TX	13.5 M	3, 6, 9

Note: Redpine software has antenna selection parameter which enables the user to select the antenna and it internally adjusts the gain parameters. Default antenna type will be Redpine PCB antenna.



Duty cycle

Power setting 1_Antenna Type: PCB Trace Antenna

Test Mode	Frequency (MHz)	on time (ms)	on+off time (ms)	Duty cycle	Duty Factor (dB)	1/T Minimum VBW (kHz)
Mode 2	2412	30.000	30.000	1.000	0.000	0.010
Mode 3	2412	30.000	30.000	1.000	0.000	0.010
Mode 4	2412	30.000	30.000	1.000	0.000	0.010
Mode 5	2422	30.000	30.000	1.000	0.000	0.010

Duty Cycle Graphs

Mode 2: IEEE 802.11b Continuous TX mode

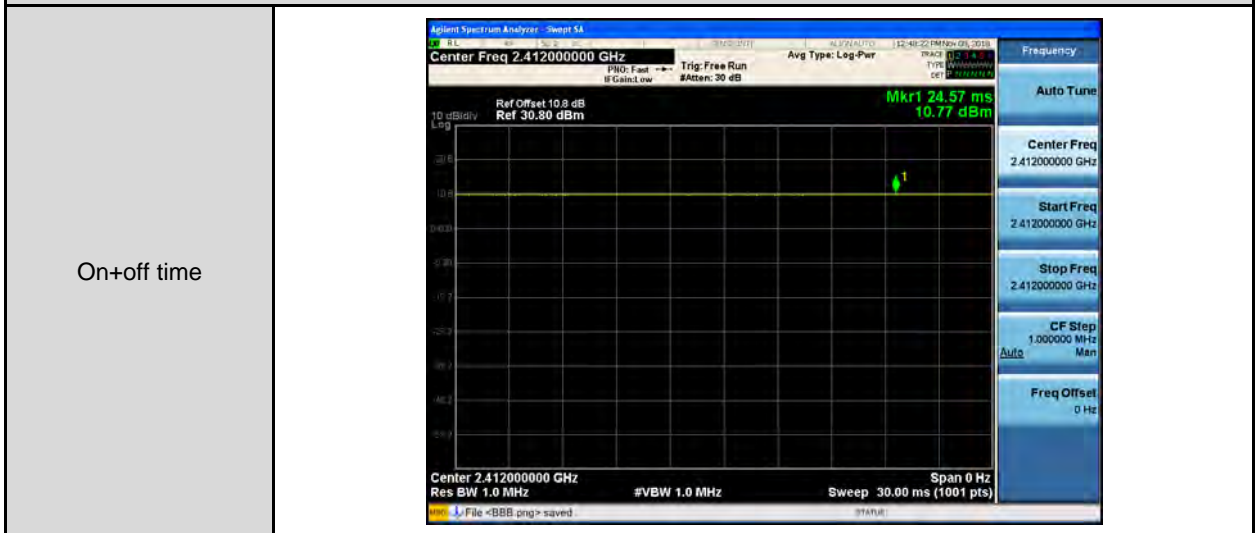

Mode 3: IEEE 802.11g Continuous TX mode

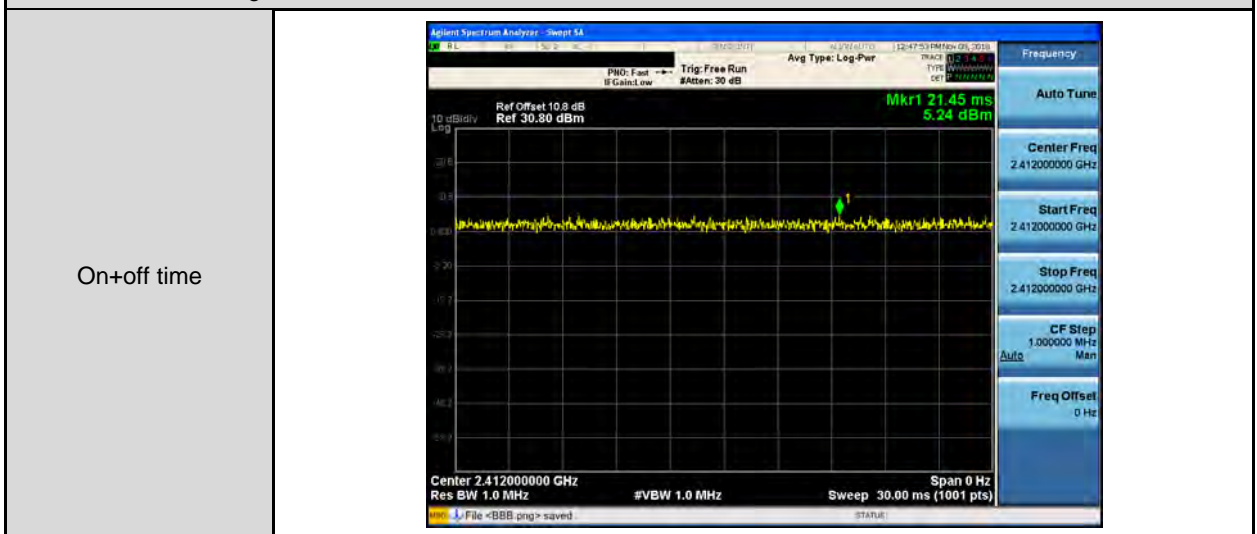

Mode 4: IEEE 802.11n 2.4 GHz 20 MHz Continuous TX mode

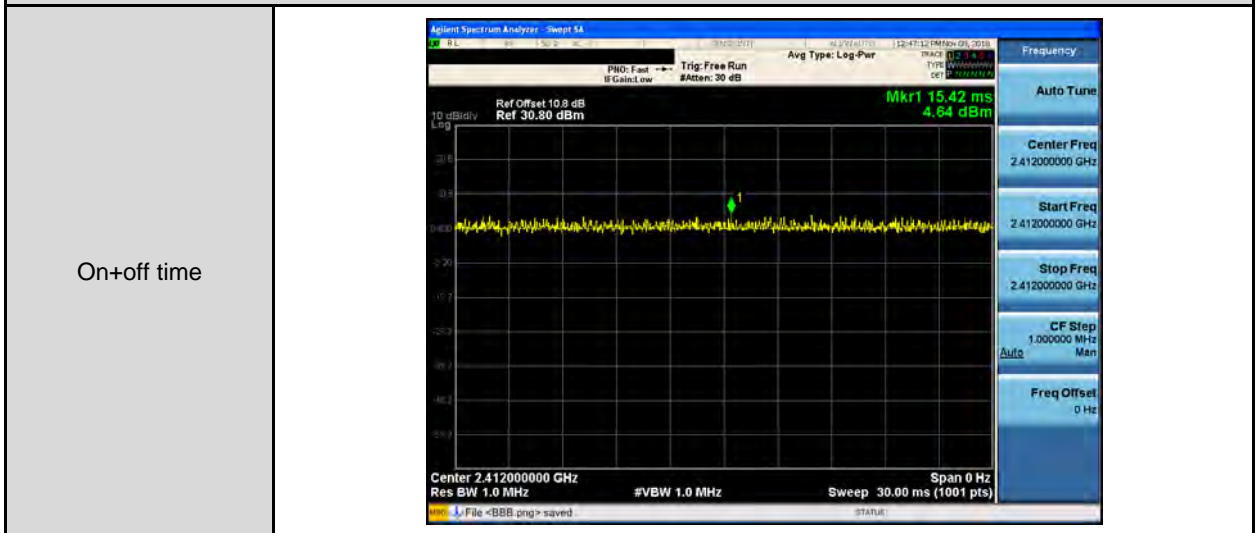

Mode 5: IEEE 802.11n 2.4 GHz 40 MHz Continuous TX mode

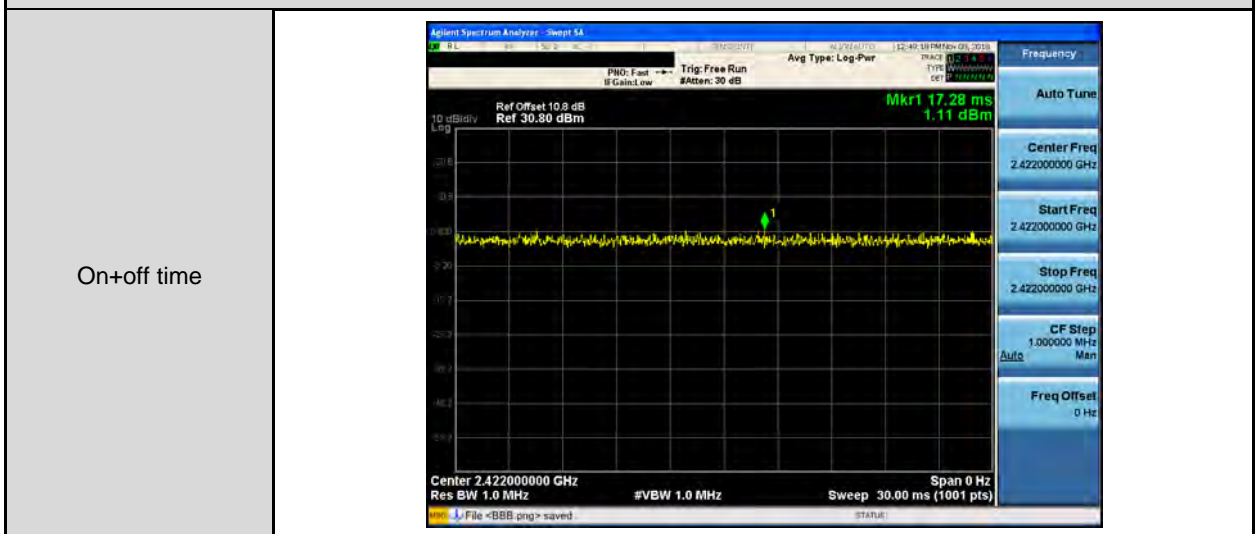



Duty Cycle

Power setting 2_Antenna Type: Heavy Duty Screw Mount Antenna

Test Mode	Frequency (MHz)	on time (ms)	on+off time (ms)	Duty cycle	Duty Factor (dB)	1/T Minimum VBW (kHz)
Mode 2	2412	30.000	30.000	1.000	0.000	0.010
Mode 3	2412	30.000	30.000	1.000	0.000	0.010
Mode 4	2412	30.000	30.000	1.000	0.000	0.010
Mode 5	2422	30.000	30.000	1.000	0.000	0.010

Duty Cycle Graphs

Mode 2: IEEE 802.11b Continuous TX mode



Mode 3: IEEE 802.11g Continuous TX mode

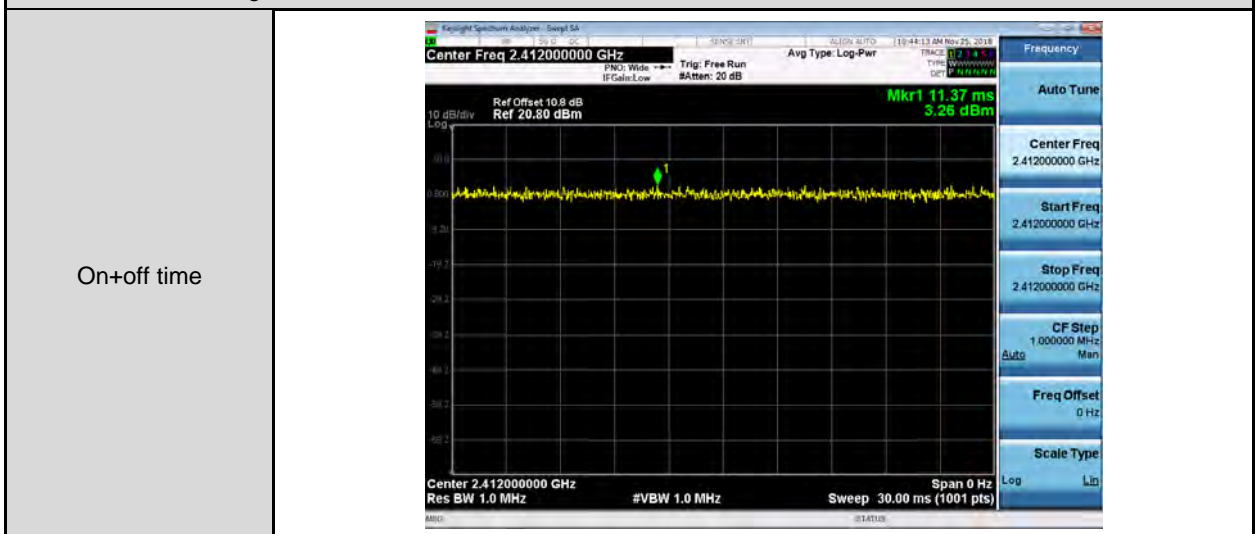

Mode 4: IEEE 802.11n 2.4 GHz 20 MHz Continuous TX mode

On+off time

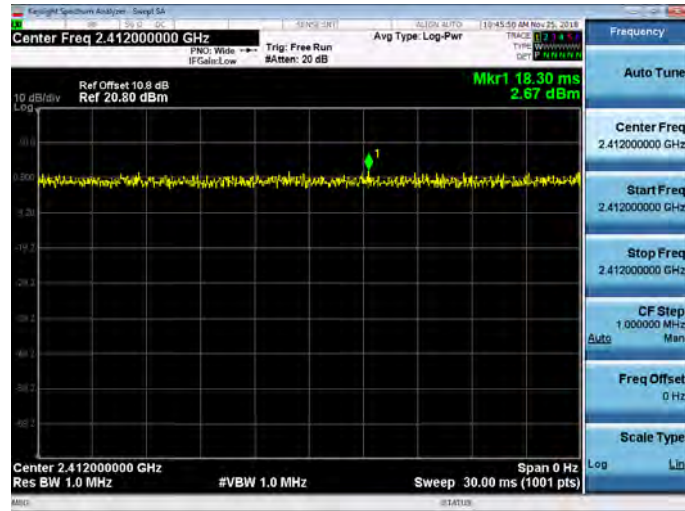

Mode 5: IEEE 802.11n 2.4 GHz 40 MHz Continuous TX mode

On+off time

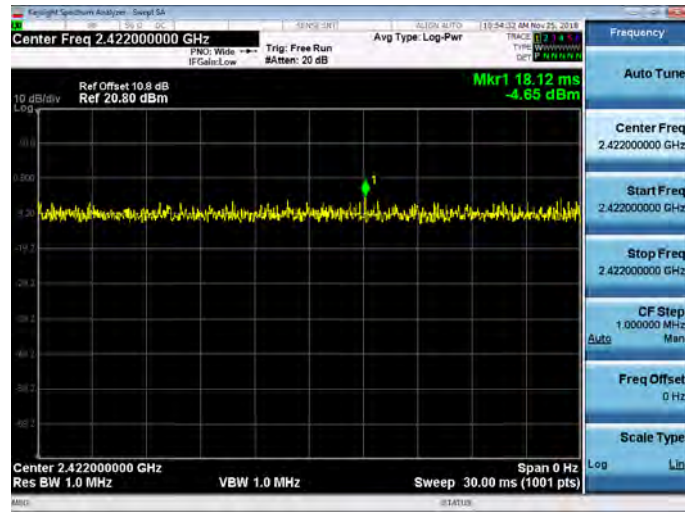



3.2. EUT Test Step

1.	Setup the EUT shown on "Configuration of Test System Details".
2.	Turn on the power of all equipment.
3.	Turn on TX function
4.	EUT run test program.

Measurement Software			
No.	Description	Software	Version
1	Radiated Emission	EZ EMC	1.1.4.4

3.3. Configuration of Test System Details

Radiated Emissions_ PCB Trace Antenna

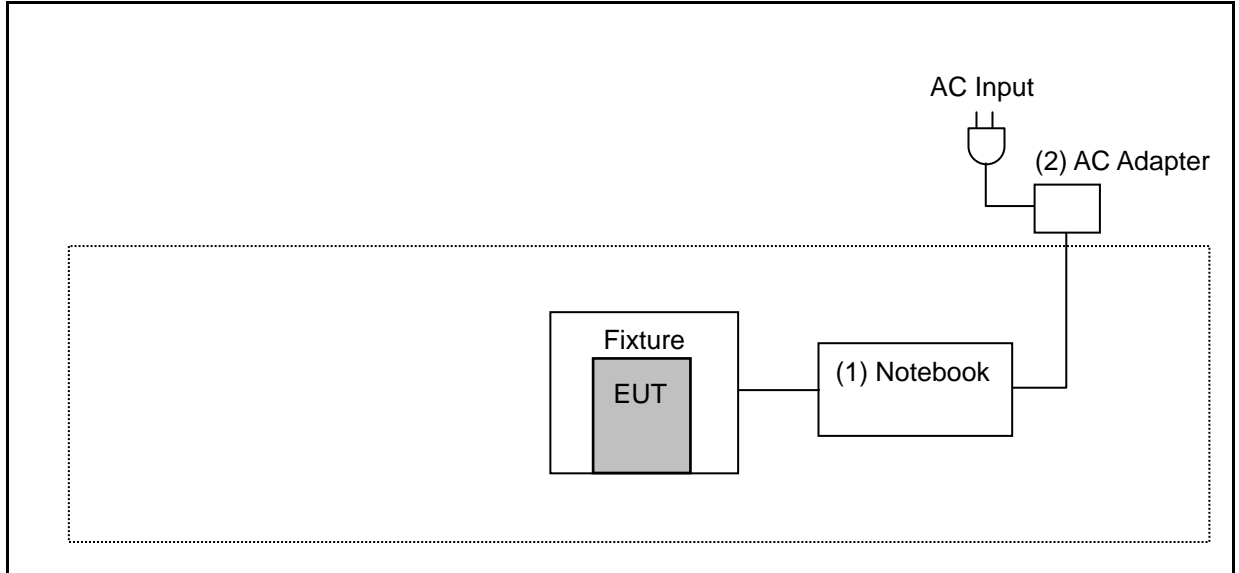

Radiated Emissions_ Heavy Duty Screw Mount Antenna

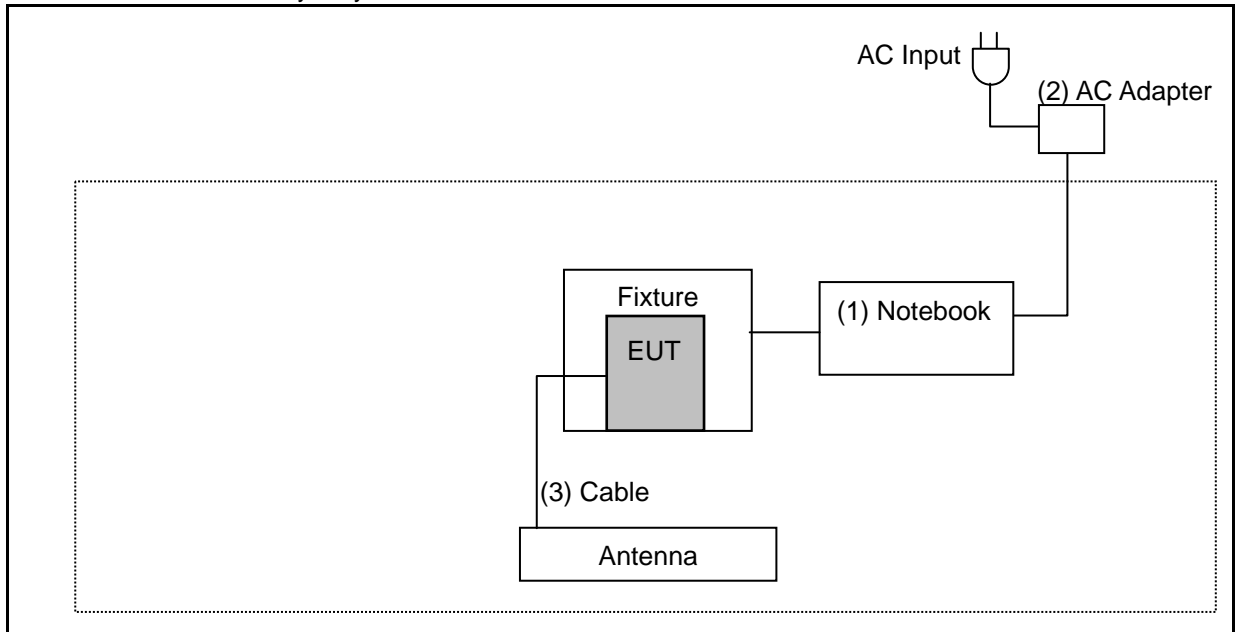

Devices Description						
	Product	Manufacturer	Model Number	Serial Number	Power Cord	Loss
(1)	Notebook	DELL	Inspiron 15	726RWN2	---	---
(2)	AC Adapter	DELL	LA65NS2-01	---	Non-Shielded, 0.8 m	---
(3)	Cable	Amphenol RF	336314-12-0100	---	---	0.38 dB



3.4. Test Instruments

For Radiated Emissions

Test Period: Nov. 06~Nov. 23, 2018

Equipment	Manufacturer	Model Number	Serial Number	Cal. Date	Cal. Period
Spectrum Analyzer (10 Hz~44 GHz)	Keysight	N9010A	MY52221312	01/15/2018	1 year
Pre Amplifier (1~26.5 GHz)	Agilent	8449B	3008A02237	10/19/2018	1 year
Pre Amplifier (100kHz~1.3GHz)	Agilent	8447D	2944A11119	01/10/2018	1 year
Trilog Broadband Antenna	SCHWARZBECK MESS-ELEKTRONIK	SB AC VULB	9168-0841	03/02/2018	1 year
Horn Antenna (1~18 GHz)	SCHWARZBECK MESS-ELEKTRONIK	BBHA9120D	9120D-550	08/23/2018	1 year
Loop Antenna	COM-POWER CORPORATION	AL-130	121014	03/13/2018	1 year
RF Cable	EMCI	EMC104-N-N-6000	TE01-1	02/20/2018	1 year
Microwave Cable	EMCI	EMC102-KM-KM-14000	151001	02/20/2018	1 year
Broadband Horn Antenna	SCHWARZBECK MESS-ELEKTRONIK	9170	9170-320	08/07/2018	1 year

Note: N.C.R. = No Calibration Request.

For Conducted

Test Period: Nov. 08~Nov. 25, 2018

Equipment	Manufacturer	Model Number	Serial Number	Cal. Date	Cal. Period
Power Sensor	Anritsu	MA2411B	1126022	08/29/2018	1 year
Power Meter	Anritsu	ML2495A	1135009	08/29/2018	1 year
EXA Signal Analyzer	Keysight	N9010A	MY52221312	01/15/2018	1 year
Microwave Cable	EMCI	EMC102-SM-SM1500	001	11/22/2017	1 year
				11/21/2018	

Note: N.C.R. = No Calibration Request.

3.5. Test Site Environment

Items	Required (IEC 60068-1)	Actual
Temperature (°C)	15-35	26
Humidity (%RH)	25-75	60
Barometric pressure (mbar)	860-1060	990



4 Measurement Procedure

4.1. Radiated Emission Measurement

■ Limit

According to §15.209(a), except as provided elsewhere in this subpart, the emissions from an intentional radiator shall not exceed the field strength levels specified in the following table:

Frequency (MHz)	Field Strength ($\mu\text{V}/\text{m}$ at meter)	Measurement Distance (meters)
0.009 – 0.490	2400 / F (kHz)	300
0.490 – 1.705	24000 / F (kHz)	30
1.705 – 30.0	30	30
30 - 88	100**	3
88-216	150**	3
216-960	200**	3
Above 960	500	3

** Except as provided in paragraph (g), fundamental emissions from intentional radiators operating under this Section shall not be located in the frequency bands 54-72 MHz, 76-88 MHz, 174-216 MHz or 470-806 MHz. However, operation within these frequency bands is permitted under other sections of this Part, e.g., Sections 15.231 and 15.241.

■ Setup

9 kHz ~ 30 MHz

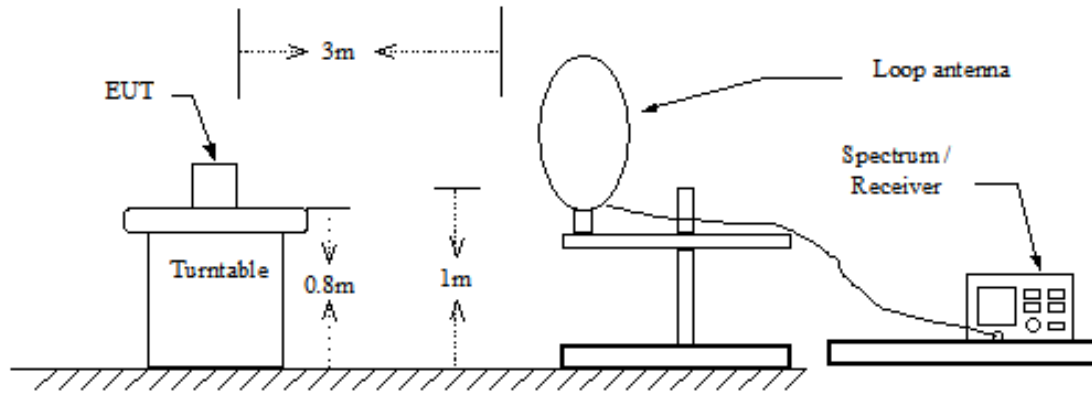

Below 1 GHz

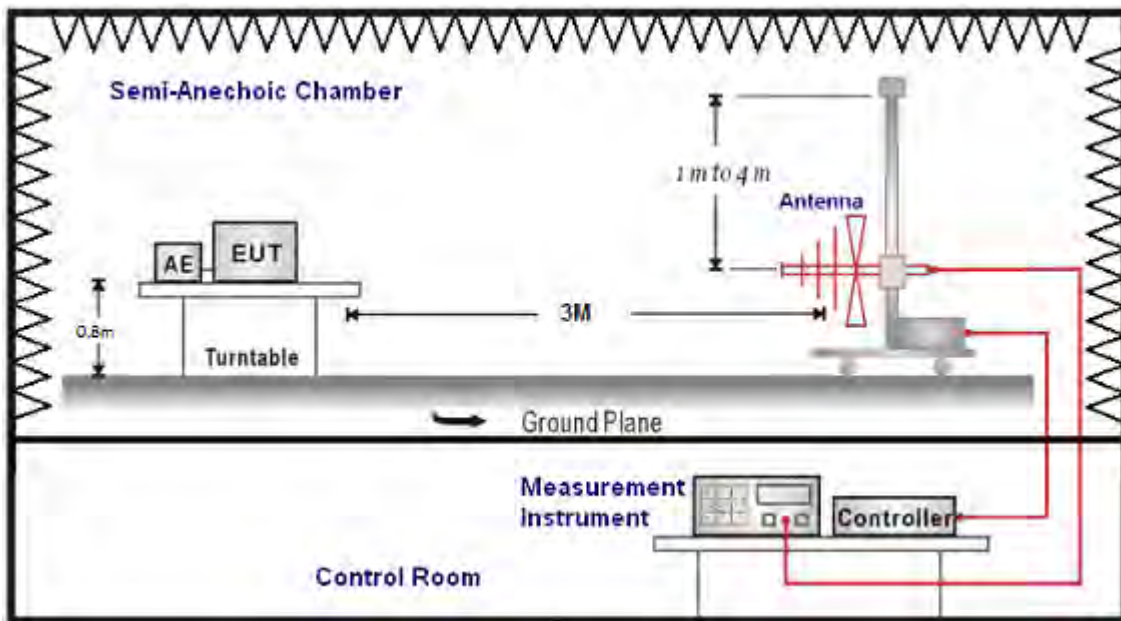

Above 1 GHz

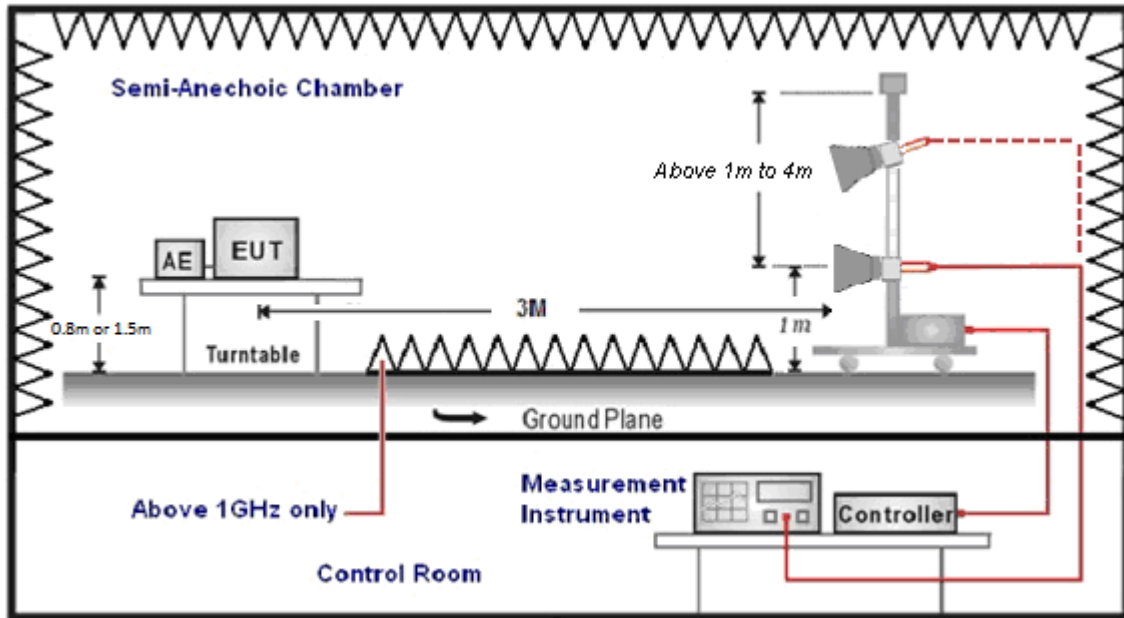



■ Test Procedure

Final radiation measurements were made on a three-meter, Semi Anechoic Chamber. The EUT system was placed on a nonconductive turntable which is 0.8 or 1.5 meters height, top surface 1.0 x 1.5 meter. The spectrum was examined from 250 MHz to 2.5 GHz in order to cover the whole spectrum below 10th harmonic which could generate from the EUT. During the test, EUT was set to transmit continuously & Measurements spectrum range from 9 kHz to 26.5 GHz is investigated.

For measurements below 1 GHz the resolution bandwidth is set to 100 kHz for peak detection measurements or 120 kHz for quasi-peak detection measurements. Peak detection is used unless otherwise noted as quasi-peak.

For measurements above 1 GHz the resolution bandwidth is set to 1 MHz, and then the video bandwidth is set to 3 MHz for peak measurements and 10 Hz for average measurements when Duty cycle >0.98 / $1/T$ for average measurements when Duty cycle <0.98 . A nonconductive material surrounded the EUT to supporting the EUT for standing on three orthogonal planes. At each condition, the EUT was rotated 360 degrees, and the antenna was raised and lowered from one to four meters to find the maximum emission levels. Measurements were taken using both horizontal and vertical antenna polarization.

SCHWARZBECK MESS-ELEKTRONIK Biconilog Antenna at 3 Meter and the SCHWARZBECK Double Ridged Guide Antenna was used in frequencies 1 –26.5 GHz at a distance of 3 meter. The antenna at an angle toward the source of the emission. All test results were extrapolated to equivalent signal at 3 meters utilizing an inverse linear distance extrapolation Factor (20 dB/decade).

For testing above 1 GHz, the emission level of the EUT in peak mode was 20 dB lower than average limit (that means the emission level in peak mode also complies with the limit in average mode), then testing will be stopped and peak values of EUT will be reported, otherwise, the emissions will be measured in average mode again and reported.

Appropriate preamplifiers were used for improving sensitivity and precautions were taken to avoid overloading or desensitizing the spectrum analyzer. No post – detector video filters were used in the test.

The spectrum analyzer's 6 dB bandwidth was set to 1 MHz, and the analyzer was operated in the peak detection mode, for frequencies both below and up 1 GHz. The average levels were obtained by subtracting the duty cycle correction factor from the peak readings.

The following procedures were used to convert the emission levels measured in decibels referenced to 1 microvolt (dBuV) into field intensity in micro volts pre meter (uV/m).

The actual field intensity in decibels referenced to 1 microvolt in to field intensity in micro volts per meter (dBuV/m).



The actual field intensity in referenced to 1 microvolt per meter (dBuV/m) is determined by algebraically adding the measured reading in dBuV, the antenna factor (dB), and cable loss (dB) and Subtracting the gain of preamplifier (dB) is auto calculate in spectrum analyzer.

(1) $\text{Amplitude (dBuV/m)} = \text{FI (dBuV)} + \text{AF (dBuV)} + \text{CL (dBuV)} - \text{Gain (dB)}$

FI= Reading of the field intensity.

AF= Antenna factor.

CL= Cable loss.

P.S Amplitude is auto calculate in spectrum analyzer.

(2) $\text{Actual Amplitude (dBuV/m)} = \text{Amplitude (dBuV)} - \text{Dis(dB)}$

The FCC specified emission limits were calculated according the EUT operating frequency and by following linear interpolation equations:

(a) For fundamental frequency : Transmitter Output < +30 dBm

(b) For spurious frequency : Spurious emission limits = fundamental emission limit /10

Data of measurement within this frequency range without mark in the table above means the reading of emissions are attenuated more than 20 dB below the permissible limits or the field strength is too small to be measured.

4.2. Maximum Conducted Output Power Measurement

■ Limit

For systems using digital modulation in the 2400-2483.5 MHz, the limit for maximum output power is 30 dBm.

And According to 15.247 (b), if transmitting antennas of directional gain greater than 6 dBi are used, the power shall be reduced by the amount in dB that the directional gain of the antenna exceeds 6 dBi.

■ Test Setup

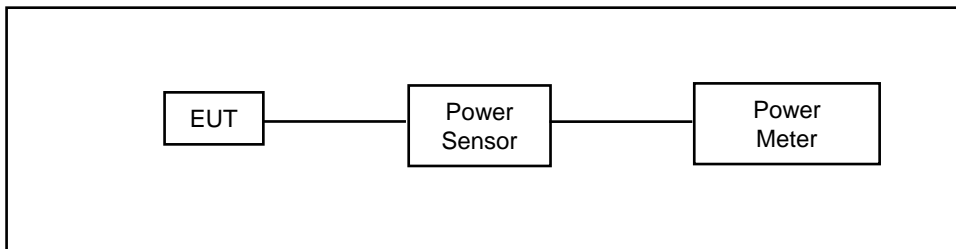

■ Test Procedure

The testing follows the Measurement Procedure of ANSI C63.10-2013 section 11.9.2.3 Method AVGPM.

The tests below are run with the EUT's transmitter set at high power in TX mode. The EUT is needed to force selection of output power level and channel number. While testing, EUT was set to transmit continuously. Remove the Subjective device's antenna and connect the RF output port to power sensor.

4.3. 6 dB RF Bandwidth Measurement

■ Limit

6 dB RF Bandwidth: Systems using digital modulation techniques may operate in the 2400–2483.5 MHz bands. The minimum 6 dB band-width shall be at least 500 kHz.

■ Test Setup

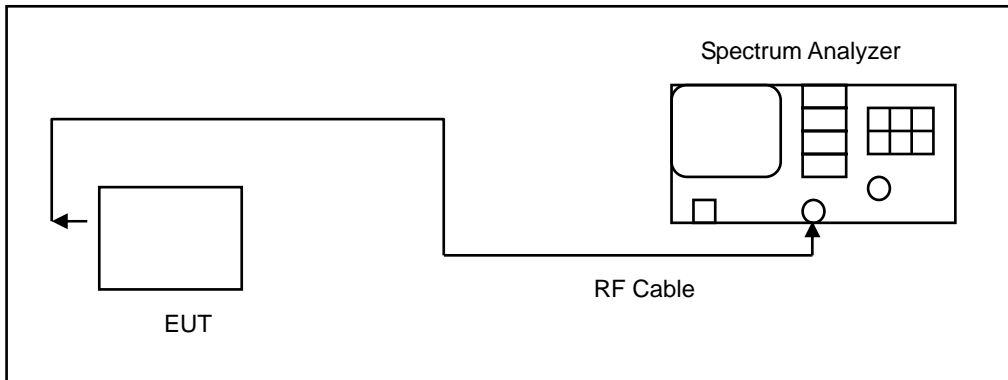

■ Test Procedure

The EUT tested to DTS test procedure of KDB 558074 D01 for compliance to FCC 47CFR 15.247 requirements.

6 dB RF Bandwidth: The antenna port of the EUT was connected to the input of a spectrum analyzer. Analyzer RBW was set to 100 kHz. For each RF output channel investigated, the spectrum analyzer center frequency was set to the channel carrier. A peak output reading was taken, a DISPLAY line was drawn 6 dB lower than peak level. The 6 dB bandwidth was determined from where the channel output spectrum intersected the display line.

The test was performed at 3 channels (Channel low, middle, high)

4.4. Maximum Power Spectral Density Measurement

■ Limit

For digitally modulated systems, the power spectral density conducted from the intentional radiator to the antenna shall not be greater than 8 dBm in any 3 kHz band during any time interval of continuous transmission.

■ Test Setup

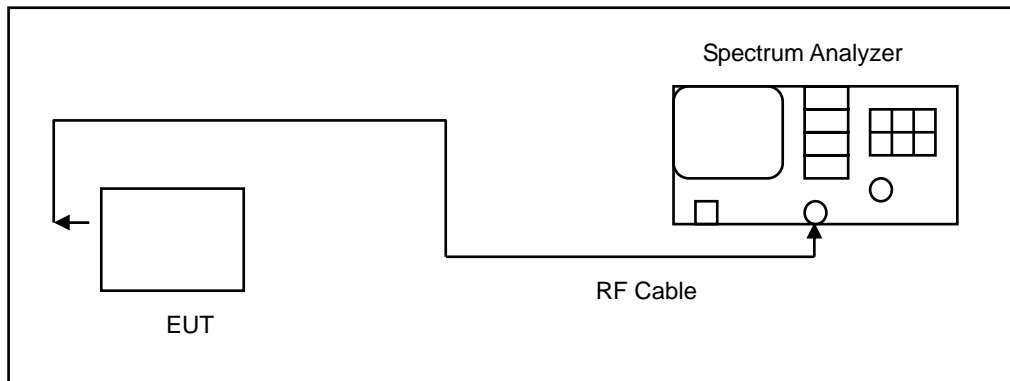

■ Test Procedure

The EUT tested to DTS test procedure of KDB 558074 D01 section 10.2 Method PKPSD for compliance to FCC 47CFR 15.247 requirements.

1. Set analyzer center frequency to DTS channel center frequency.
2. Set the span to 1.5 times the DTS bandwidth.
3. Set the RBW to: $3 \text{ kHz} \leq \text{RBW} \leq 100 \text{ kHz}$.
4. Set the VBW $\geq 3 \times \text{RBW}$.
5. Detector = peak.
6. Sweep time = auto couple.
7. Trace mode = max hold.
8. Allow trace to fully stabilize.
9. Use the peak marker function to determine the maximum amplitude level within the RBW.
10. If measured value exceeds limit, reduce RBW (no less than 3 kHz) and repeat.

4.5. Out of Band Conducted Emissions Measurement

■ **Limit**

In any 100 kHz bandwidth outside the frequency band in which the spread spectrum or digitally modulated intentional radiator is operating, the radio frequency power that is produced by the intentional radiator shall be at least 20 dB below that in the 100 kHz bandwidth within the band that contains the highest level of the desired power

■ **Test Setup**

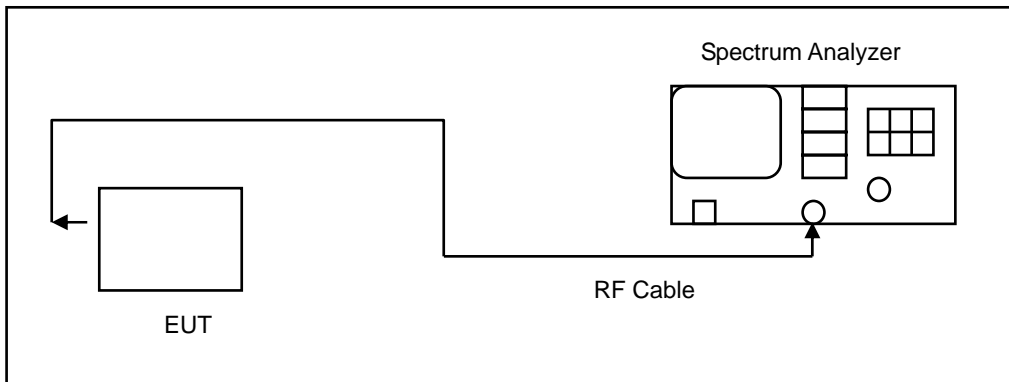

■ **Test Procedure**

In any 100 kHz bandwidth outside the EUT pass band, the RF power produced by the modulation products of the spreading sequence, the information sequence, and the carrier frequency shall be at least 20 dB below that of the maximum in-band 100 kHz emission, antenna output of the EUT was coupled directly to spectrum analyzer; if an external attenuator and/or cable was used, these losses are compensated for with the analyzer OFFSET function. All other types of emissions from the EUT shall meet the general limits for radiated frequencies outside the pass band. The test was performed at 3 channels.



4.6. Antenna Measurement

■ Limit

For intentional device, according to 15.203, an intentional radiator shall be designed to ensure that no antenna other than that furnished by the responsible party shall be used with the device.

And According to 15.247 (b), if transmitting antennas of directional gain greater than 6 dBi are used, the power shall be reduced by the amount in dB that the directional gain of the antenna exceeds 6 dBi.

■ Antenna Description

See section 2 – antenna information.



5 Test Results

Annex A. Conducted Test Results

Power setting 1_Antenna Type: PCB Trace Antenna

Maximum Conducted Output Power Measurement

Test Mode	Frequency (MHz)	RF Power setting in Test Software	Test Software Version
Mode 2	2412	20.0	Terminal
	2437	18.0	
	2462	18.0	
Mode 3	2412	12.0	
	2437	22.0	
	2462	13.0	
Mode 4	2412	11.0	
	2437	22.0	
	2462	12.0	
Mode 5	2422	8.0	
	2437	11.0	
	2452	8.0	

Test Mode	Data Rate (Mbps)	Frequency (MHz)	Average Output Power		Peak Output Power		
			Measurement Results		Measurement Results		Limit
			dBm	W	dBm	W	dBm
Mode 2	1	2412	16.36	0.043	18.58	0.072	≤ 30
		2437	16.17	0.041	18.30	0.068	≤ 30
		2462	16.53	0.045	18.75	0.075	≤ 30
	2	2437	16.16	0.041	18.28	0.067	≤ 30
	5.5	2437	16.15	0.041	18.27	0.067	≤ 30
	11	2437	16.12	0.041	18.26	0.067	≤ 30
Mode 3	6	2412	9.46	0.009	15.59	0.036	≤ 30
		2437	17.04	0.051	21.65	0.146	≤ 30
		2462	11.52	0.014	17.81	0.060	≤ 30
	9	2437	17.03	0.050	21.58	0.144	≤ 30
	12	2437	17.01	0.050	21.56	0.143	≤ 30
	18	2437	17.00	0.050	21.54	0.143	≤ 30
	24	2437	16.99	0.050	21.53	0.142	≤ 30
	36	2437	16.97	0.050	21.52	0.142	≤ 30
	48	2437	16.96	0.050	21.50	0.141	≤ 30
	54	2437	16.94	0.049	21.49	0.141	≤ 30

Note: The relevant measured result has the offset with cable loss already.



Test Mode	Data Rate (Mbps)	Frequency (MHz)	Average Output Power		Peak Output Power		
			Measurement Results		Measurement Results		Limit
			dBm	W	dBm	W	dBm
Mode 4	6.5M	2412	8.91	0.008	15.48	0.035	≤ 30
		2437	17.38	0.055	22.04	0.160	≤ 30
		2462	10.86	0.012	17.63	0.058	≤ 30
	14.4M	2437	17.36	0.054	21.96	0.157	≤ 30
	21.7M	2437	17.34	0.054	21.95	0.157	≤ 30
	28.9M	2437	17.33	0.054	21.93	0.156	≤ 30
	43.3M	2437	17.32	0.054	21.92	0.156	≤ 30
	57.8M	2437	17.30	0.054	21.90	0.155	≤ 30
	65M	2437	17.29	0.054	21.89	0.155	≤ 30
	72.2M	2437	17.28	0.053	21.88	0.154	≤ 30
Mode 5	13.5M	2422	6.95	0.005	14.07	0.026	≤ 30
		2437	10.50	0.011	17.99	0.063	≤ 30
		2452	7.72	0.006	14.76	0.030	≤ 30
	30M	2437	10.48	0.011	17.91	0.062	≤ 30
	45M	2437	10.47	0.011	17.89	0.062	≤ 30
	60M	2437	10.45	0.011	17.88	0.061	≤ 30
	90M	2437	10.44	0.011	17.86	0.061	≤ 30
	120M	2437	10.43	0.011	17.85	0.061	≤ 30
	135M	2437	10.42	0.011	17.83	0.061	≤ 30
	150M	2437	10.41	0.011	17.81	0.060	≤ 30

Note: The relevant measured result has the offset with cable loss already.

**6 dB RF Bandwidth Measurement**

Test Mode	Frequency (MHz)	Measurement (kHz)	Limit (kHz)
Mode 2	2412	9086	≥ 500
	2437	9079	≥ 500
	2462	8588	≥ 500
Mode 3	2412	16560	≥ 500
	2437	16590	≥ 500
	2462	16570	≥ 500
Mode 4	2412	17760	≥ 500
	2437	17730	≥ 500
	2462	17760	≥ 500
Mode 5	2422	36470	≥ 500
	2437	36460	≥ 500
	2452	36420	≥ 500

■ Test Graphs

Mode 2: IEEE 802.11b Continuous TX mode

<p>2412 MHz</p>	<p>Center Freq: 2.412000000 GHz #Res BW: 100 kHz #VBW: 300 kHz Span: 30 MHz Sweep: 2.933 ms</p> <p>Occupied Bandwidth: 14.361 MHz Total Power: 23.5 dBm Transmit Freq Error: 37.803 kHz OBW Power: 99.00 % x dB Bandwidth: 9.086 MHz x dB: -6.00 dB</p>
<p>2437 MHz</p>	<p>Center Freq: 2.437000000 GHz #Res BW: 100 kHz #VBW: 300 kHz Span: 30 MHz Sweep: 2.933 ms</p> <p>Occupied Bandwidth: 14.175 MHz Total Power: 23.1 dBm Transmit Freq Error: 20.616 kHz OBW Power: 99.00 % x dB Bandwidth: 9.079 MHz x dB: -6.00 dB</p>
<p>2462 MHz</p>	<p>Center Freq: 2.462000000 GHz #Res BW: 100 kHz #VBW: 300 kHz Span: 30 MHz Sweep: 2.933 ms</p> <p>Occupied Bandwidth: 14.145 MHz Total Power: 23.6 dBm Transmit Freq Error: 17.438 kHz OBW Power: 99.00 % x dB Bandwidth: 8.588 MHz x dB: -6.00 dB</p>



Mode 3: IEEE 802.11g Continuous TX mode

2412 MHz

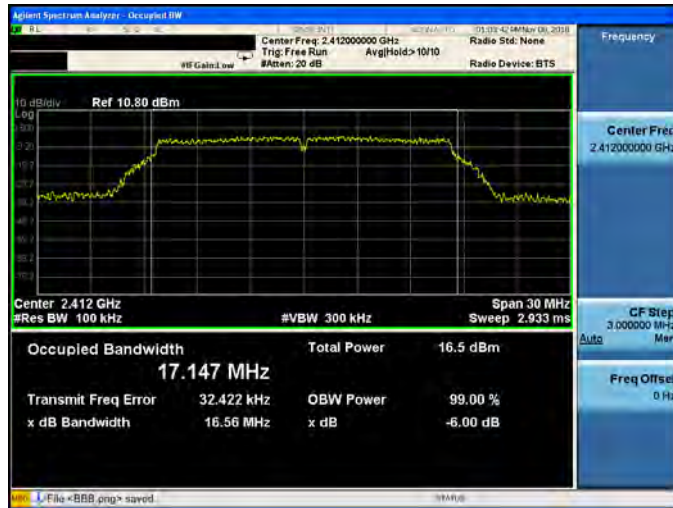

2437 MHz

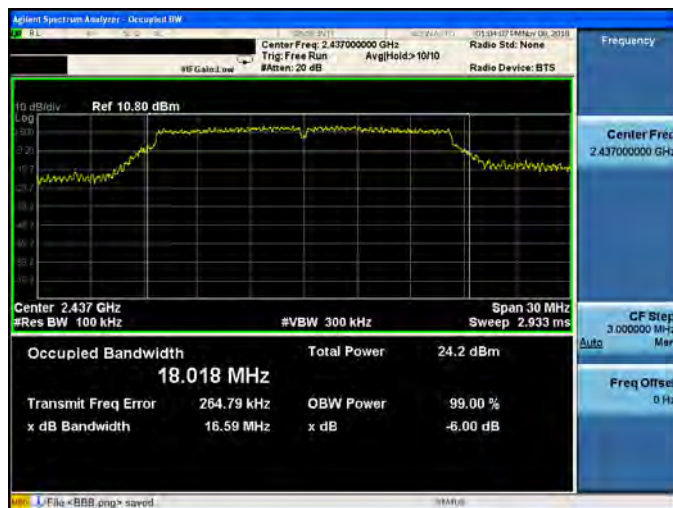

2462 MHz

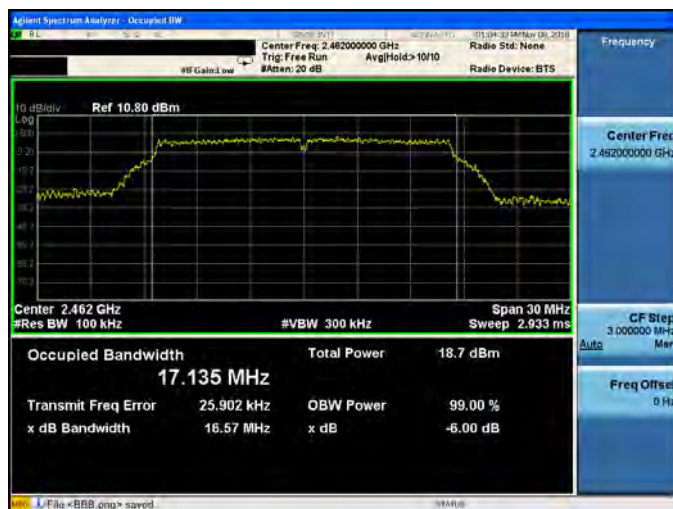



Mode 4: IEEE 802.11n 2.4 GHz 20 MHz Continuous TX mode

2412 MHz

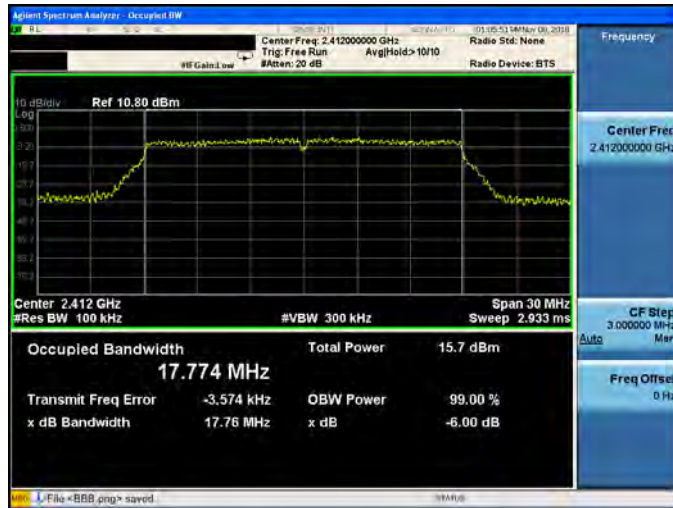

2437 MHz

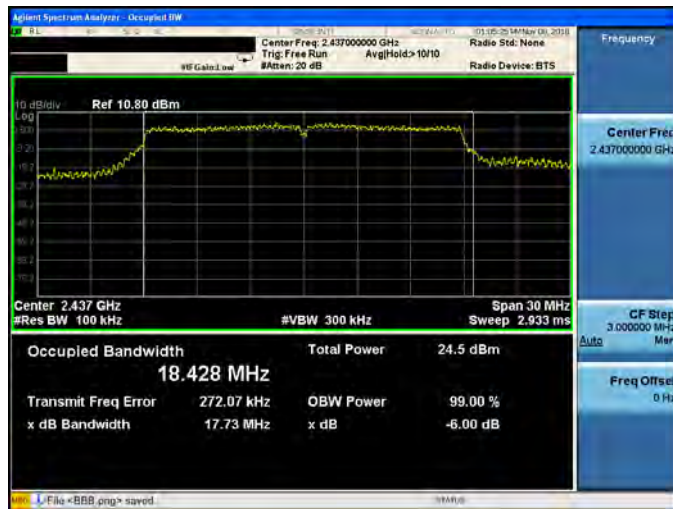

2462 MHz





Mode 5: IEEE 802.11n 2.4 GHz 40 MHz Continuous TX mode

2422 MHz

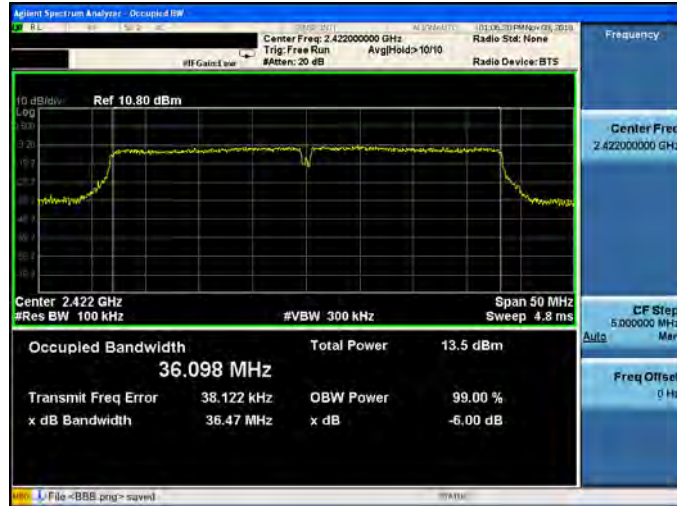

2437 MHz

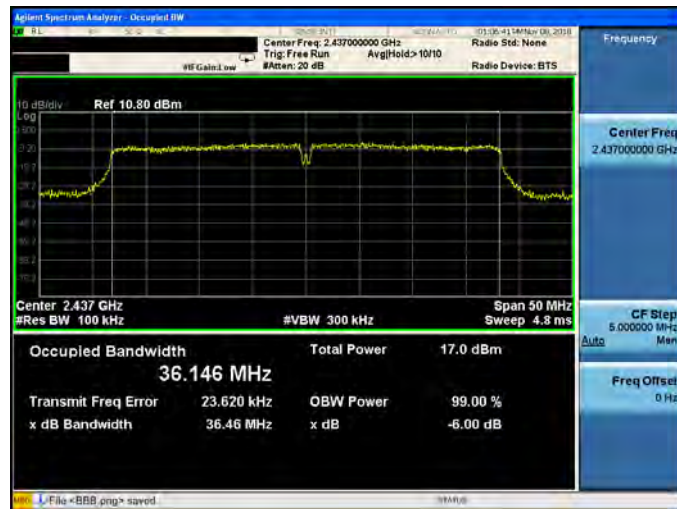

2452 MHz

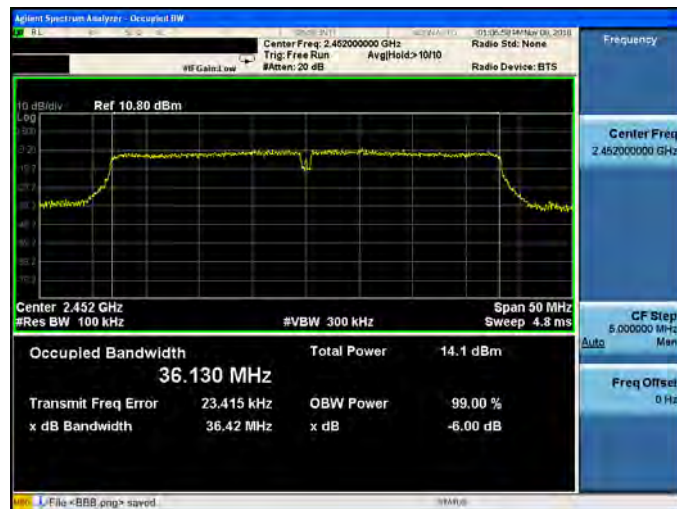

**Maximum Power Spectral Density Measurement**

Test Mode	Frequency (MHz)	Measurement (dBm/3 kHz)	Limit (dBm/3 kHz)
Mode 2	2412	-8.066	≤ 8
	2437	-8.584	≤ 8
	2462	-7.957	≤ 8
Mode 3	2412	-15.680	≤ 8
	2437	-7.640	≤ 8
	2462	-13.408	≤ 8
Mode 4	2412	-16.417	≤ 8
	2437	-7.680	≤ 8
	2462	-13.624	≤ 8
Mode 5	2422	-19.750	≤ 8
	2437	-14.775	≤ 8
	2452	-18.916	≤ 8



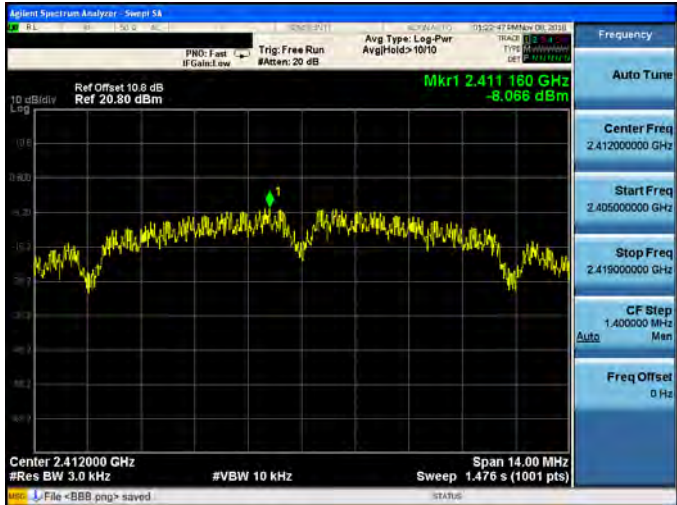
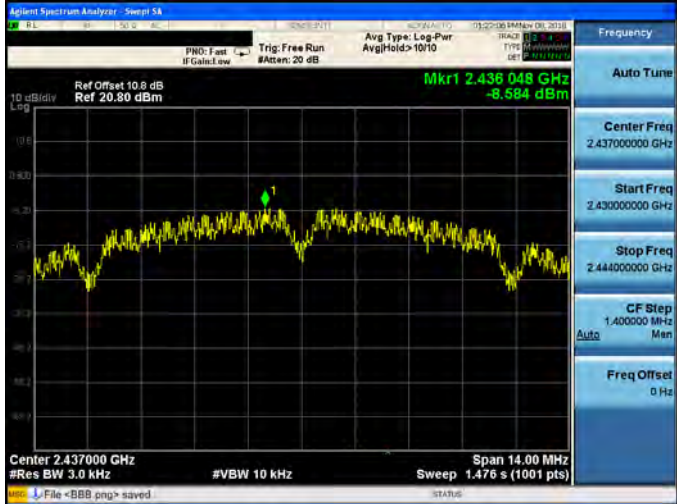
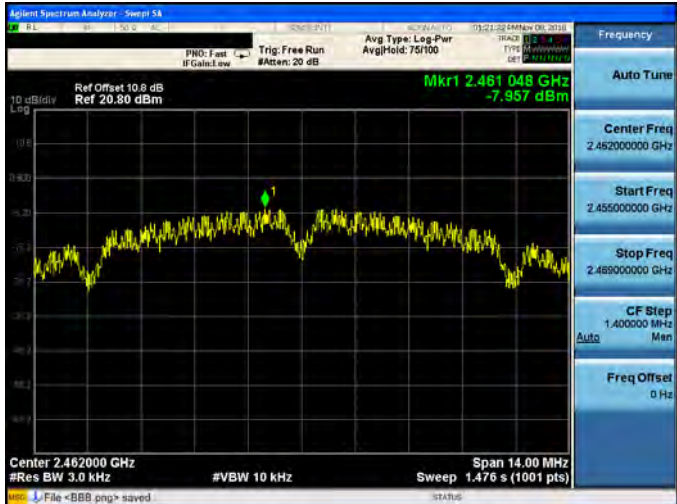

■ Test Graphs

Mode 2: IEEE 802.11b Continuous TX mode

2412 MHz	
2437 MHz	
2462 MHz	

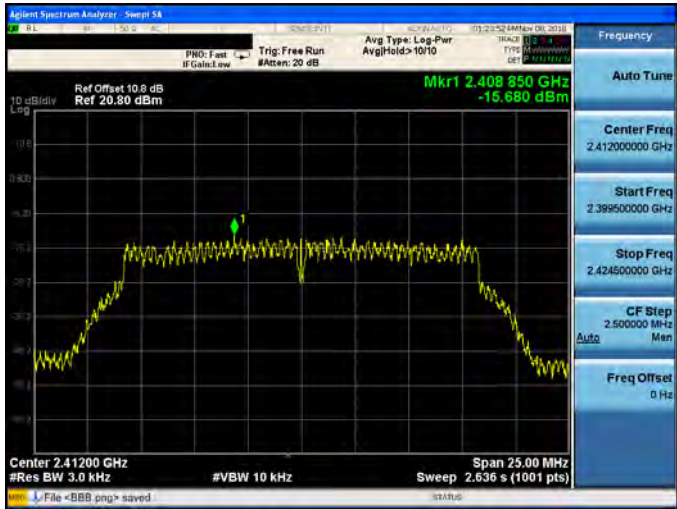
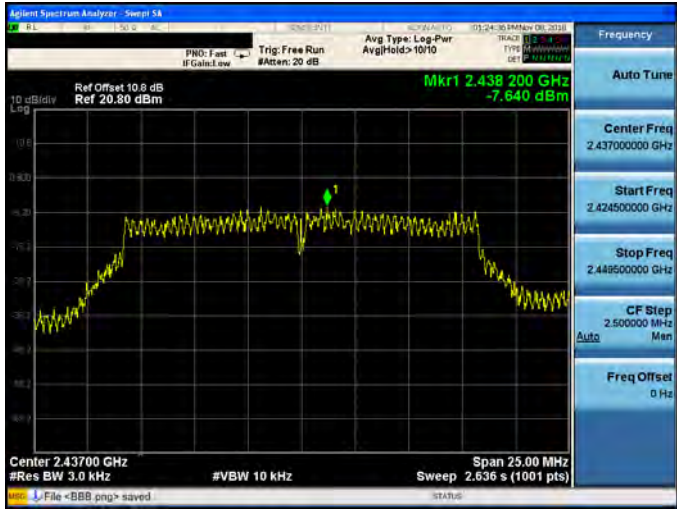

Mode 3: IEEE 802.11g Continuous TX mode

<p>2412 MHz</p>	
<p>2437 MHz</p>	
<p>2462 MHz</p>	



Mode 4: IEEE 802.11n 2.4 GHz 20 MHz Continuous TX mode

2412 MHz



2437 MHz

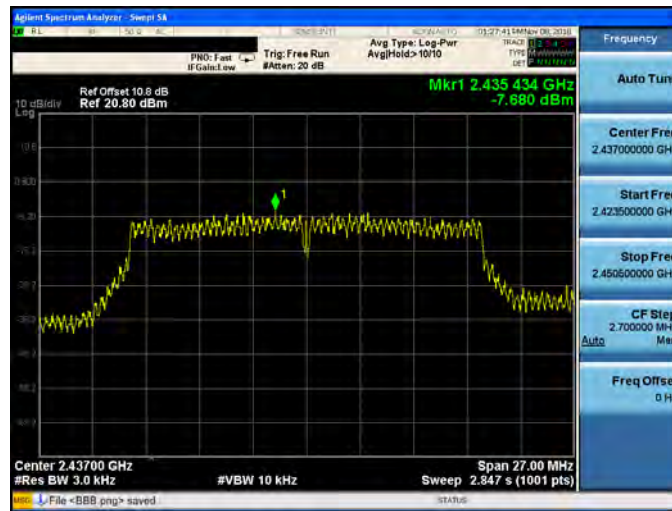

2462 MHz





Mode 5: IEEE 802.11n 2.4 GHz 40 MHz Continuous TX mode

2422 MHz

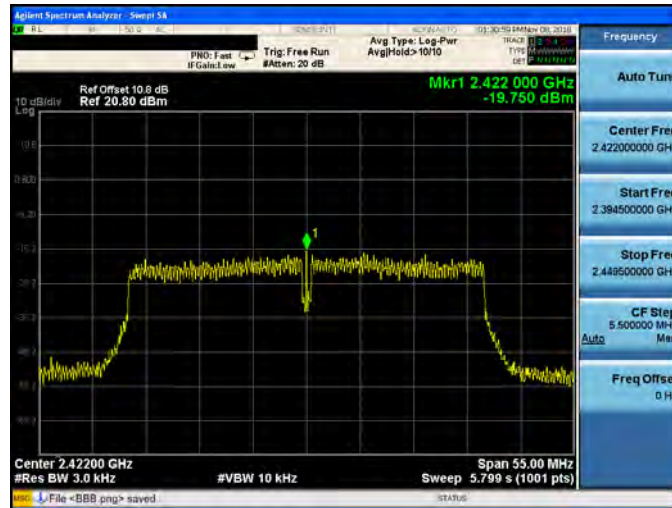

2437 MHz

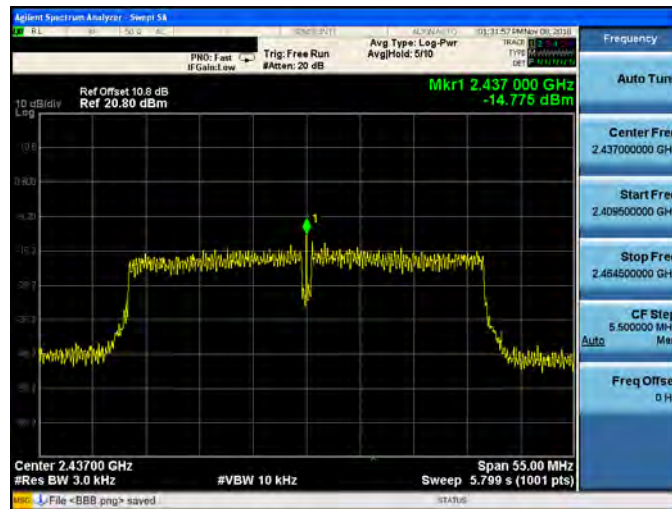

2452 MHz

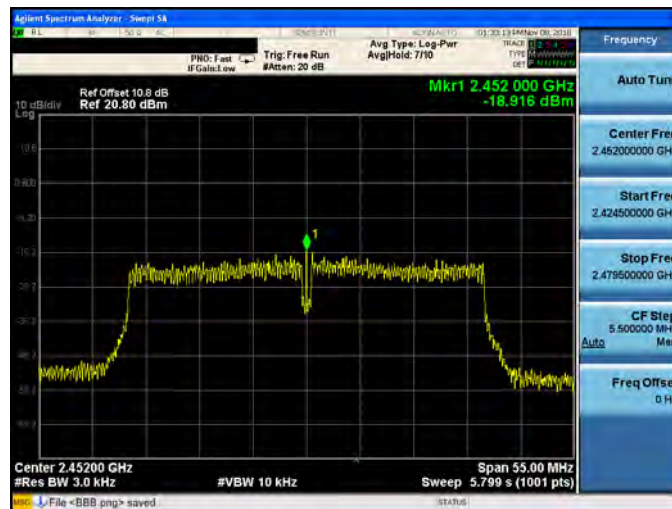

Out of Band Conducted Emissions Measurement

■ Test Graphs

Reference level

Mode 2: IEEE 802.11b Continuous TX mode	
2412 MHz	
2437 MHz	
2462 MHz	

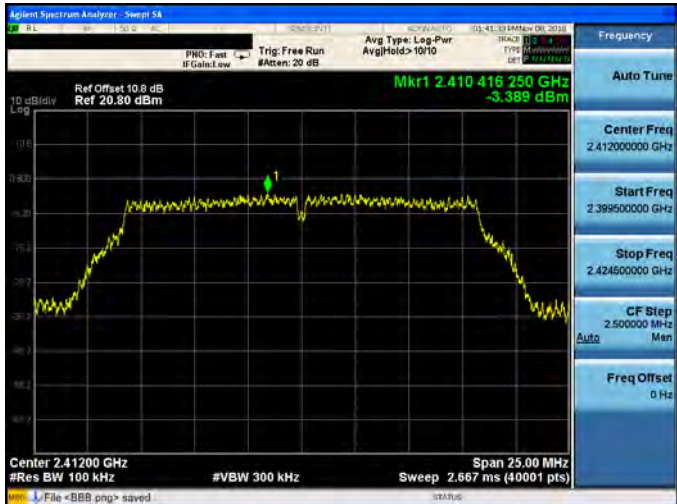
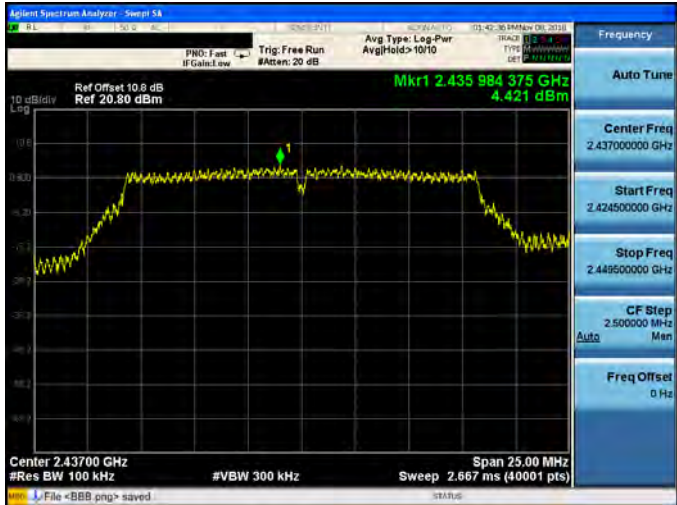
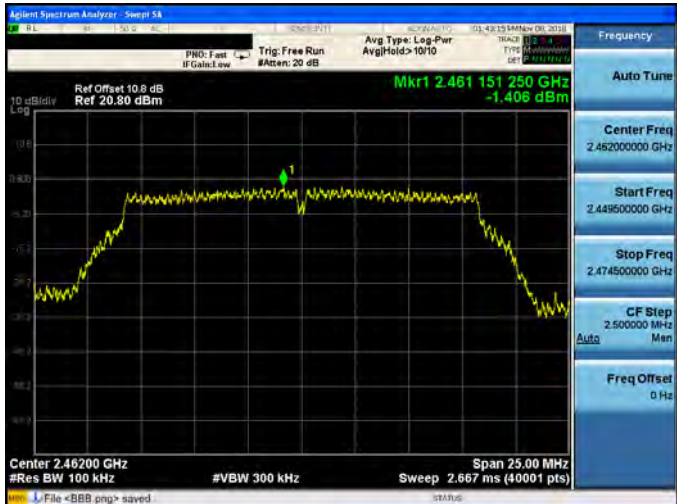

Mode 3: IEEE 802.11g Continuous TX mode

2412 MHz	
2437 MHz	
2462 MHz	



Mode 4: IEEE 802.11n 2.4 GHz 20 MHz Continuous TX mode

2412 MHz



2437 MHz



2462 MHz

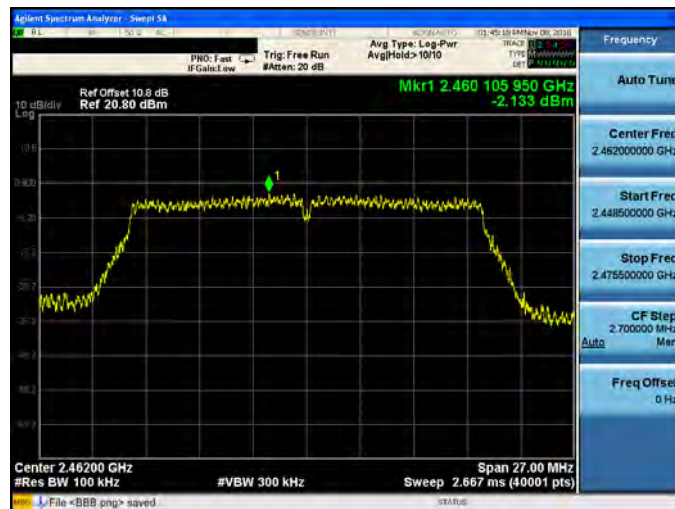



Mode 5: IEEE 802.11n 2.4 GHz 40 MHz Continuous TX mode

2422 MHz



2437 MHz



2452 MHz



Out of Band Conducted Emissions

Mode 2: IEEE 802.11b Continuous TX mode

<p>2412 MHz</p>	
<p>2437 MHz</p>	
<p>2462 MHz</p>	



Mode 3: IEEE 802.11g Continuous TX mode

2412 MHz

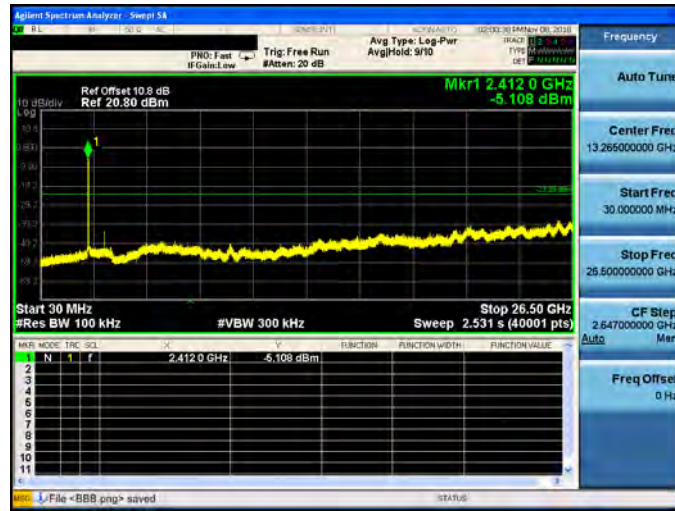

2437 MHz

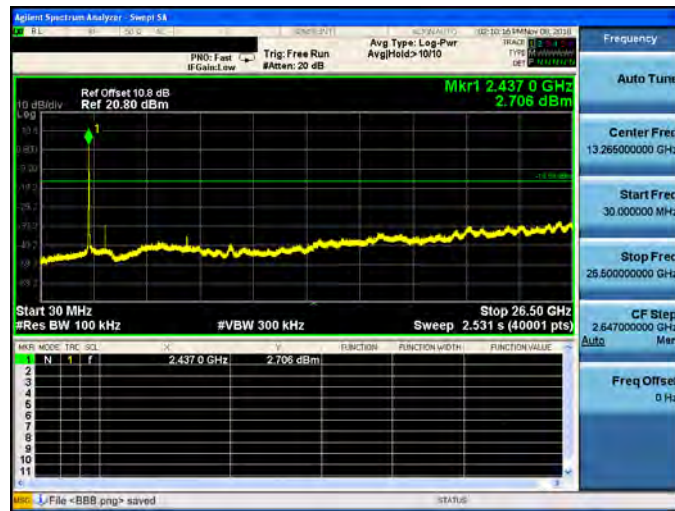

2462 MHz

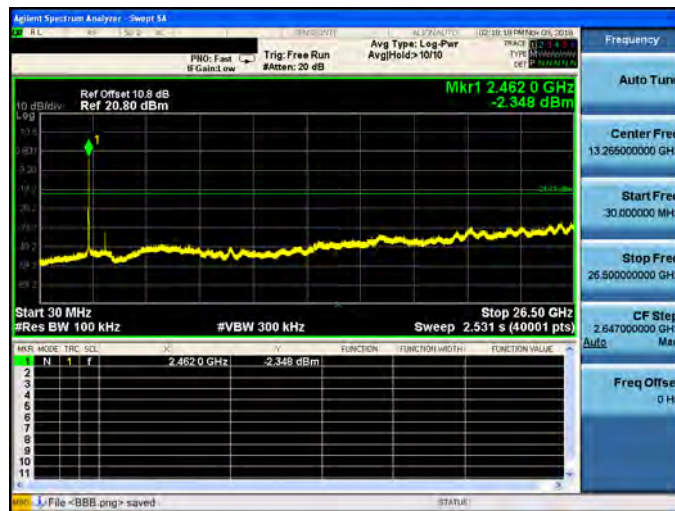



Mode 4: IEEE 802.11n 2.4 GHz 20 MHz Continuous TX mode

2412 MHz

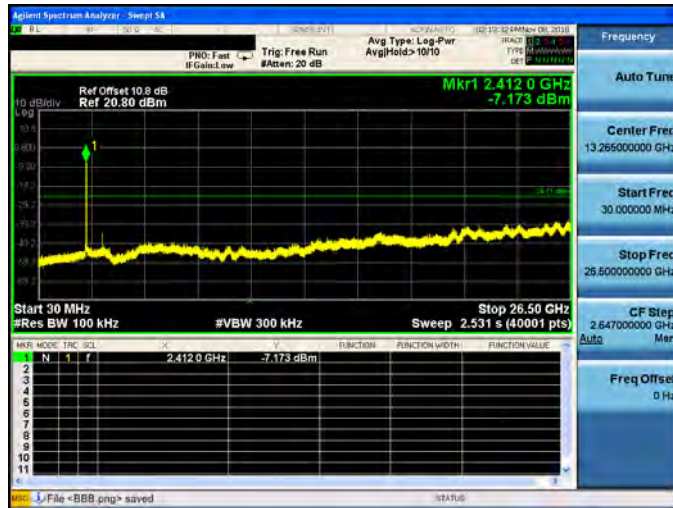

2437 MHz

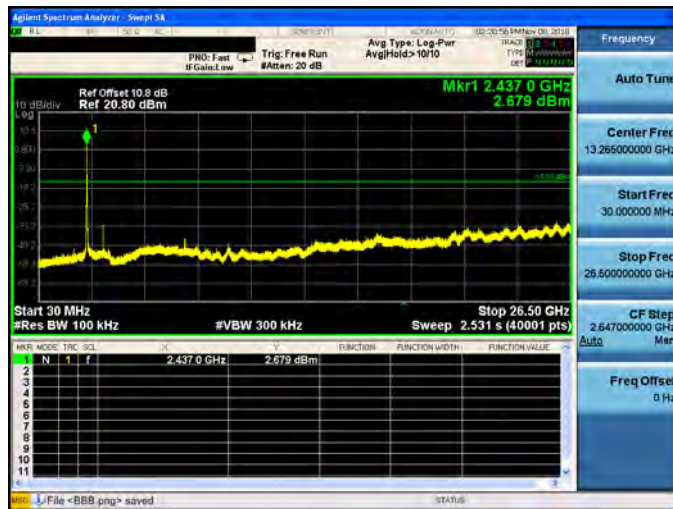

2462 MHz

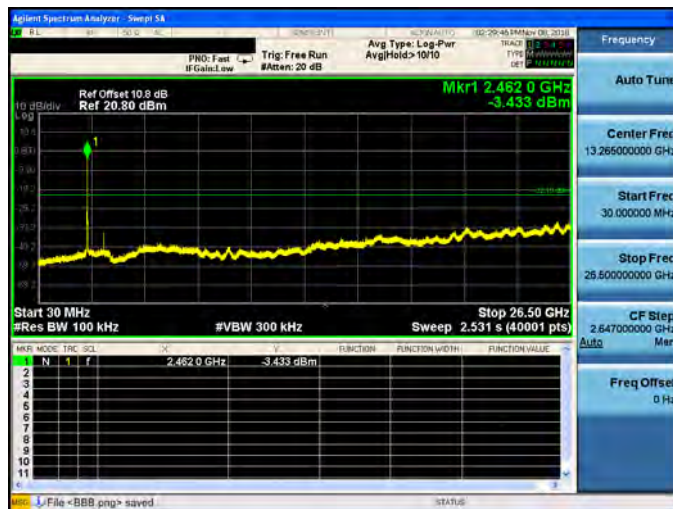



Mode 5: IEEE 802.11n 2.4 GHz 40 MHz Continuous TX mode

2422 MHz

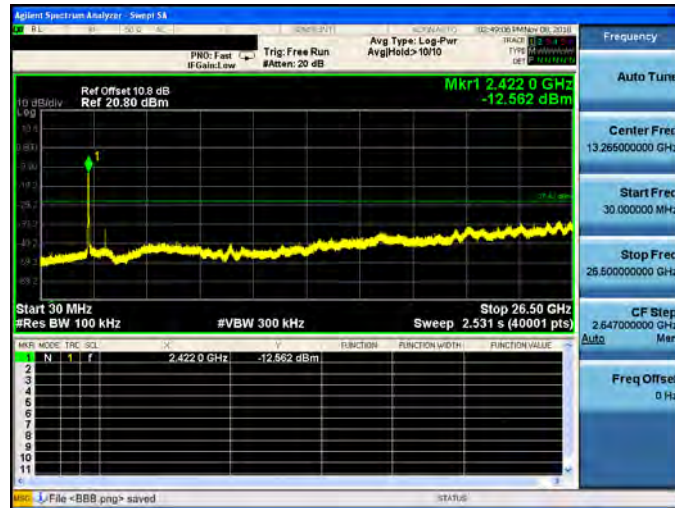

2437 MHz

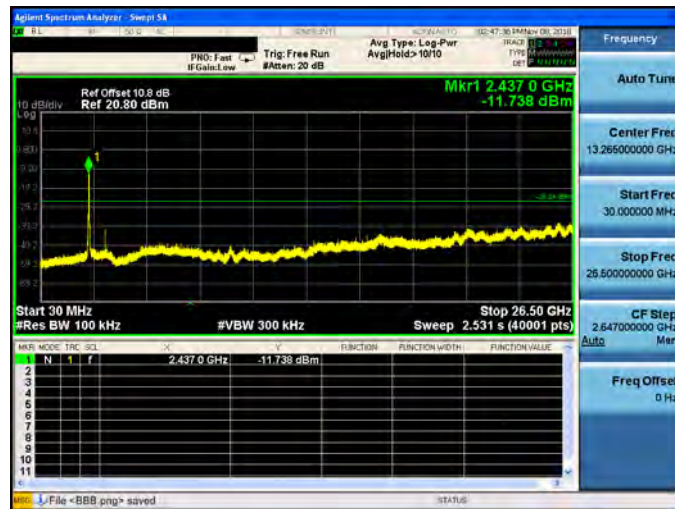

2452 MHz

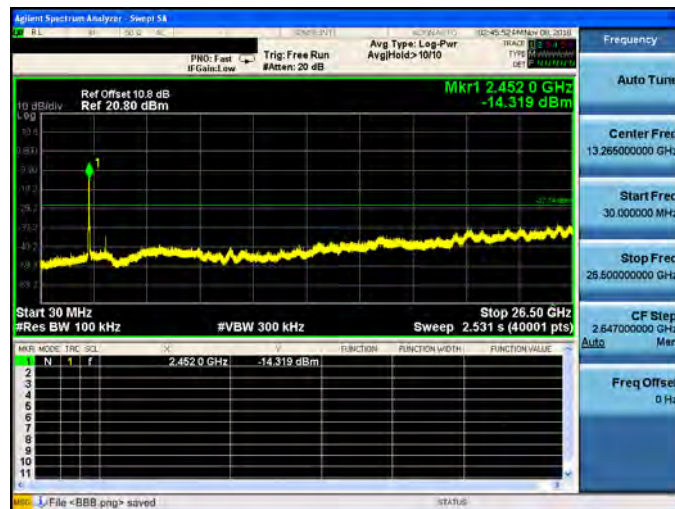

Conducted Band Edge

Mode 2: IEEE 802.11b Continuous TX mode

2412 MHz

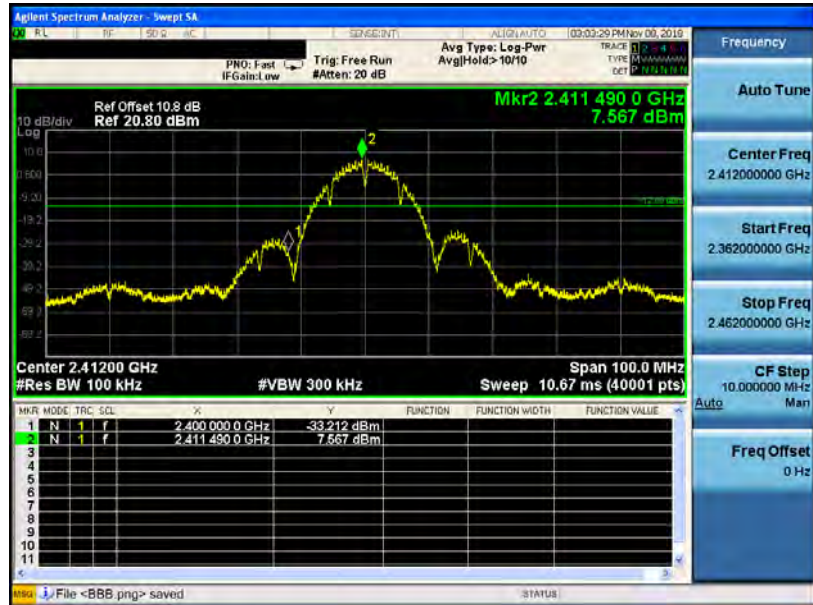

2462 MHz

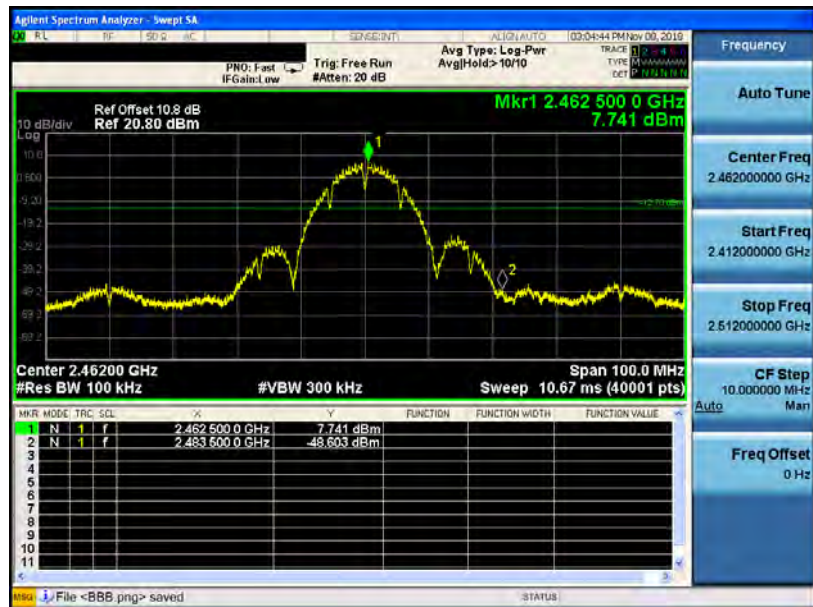

Mode 3: IEEE 802.11g Continuous TX mode

2412 MHz

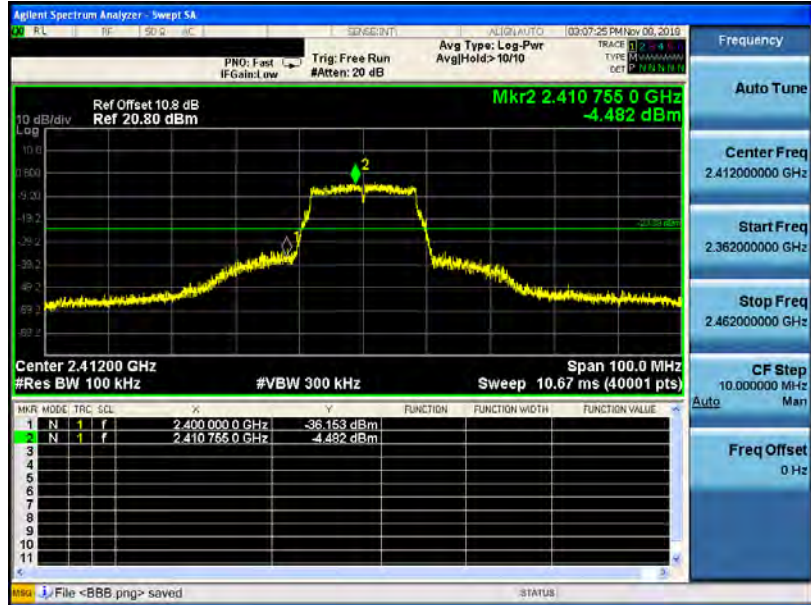

2462 MHz

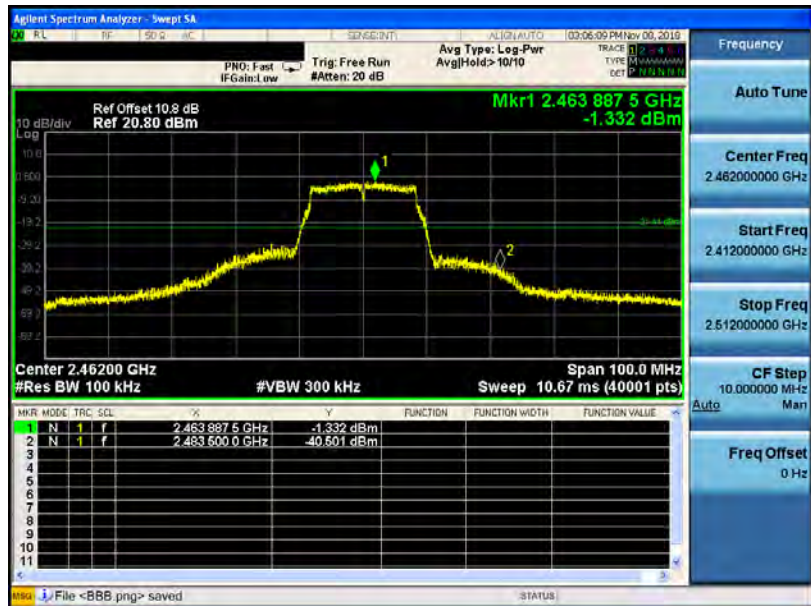

Mode 4: IEEE 802.11n 2.4 GHz 20 MHz Continuous TX mode

2412 MHz

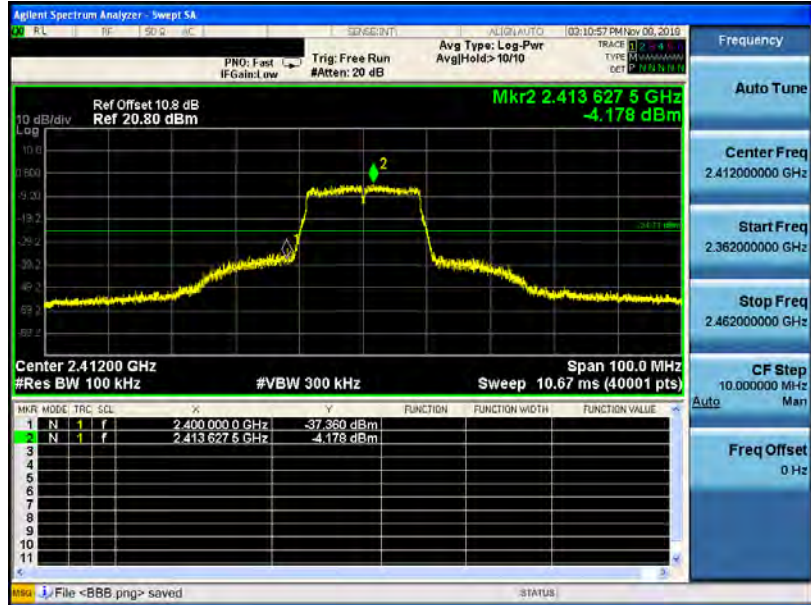

2462 MHz

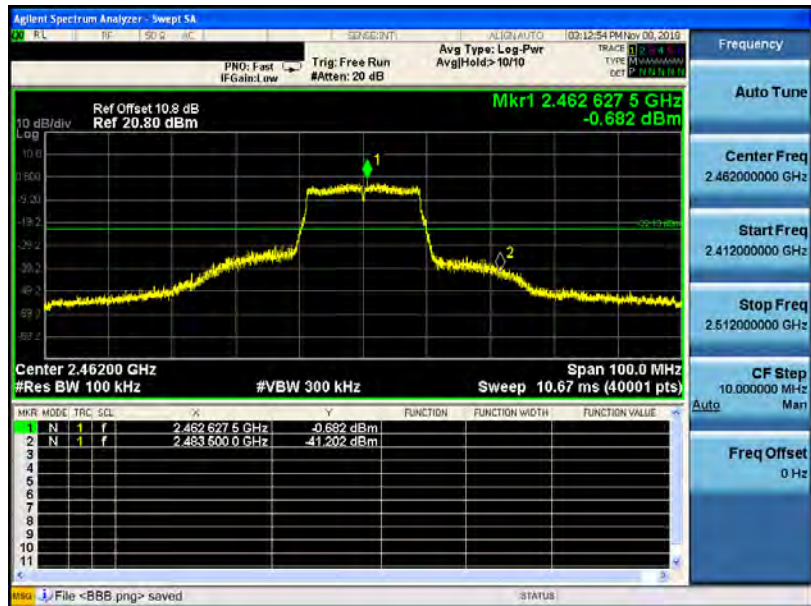

Mode 5: IEEE 802.11n 2.4 GHz 40 MHz Continuous TX mode

2422 MHz

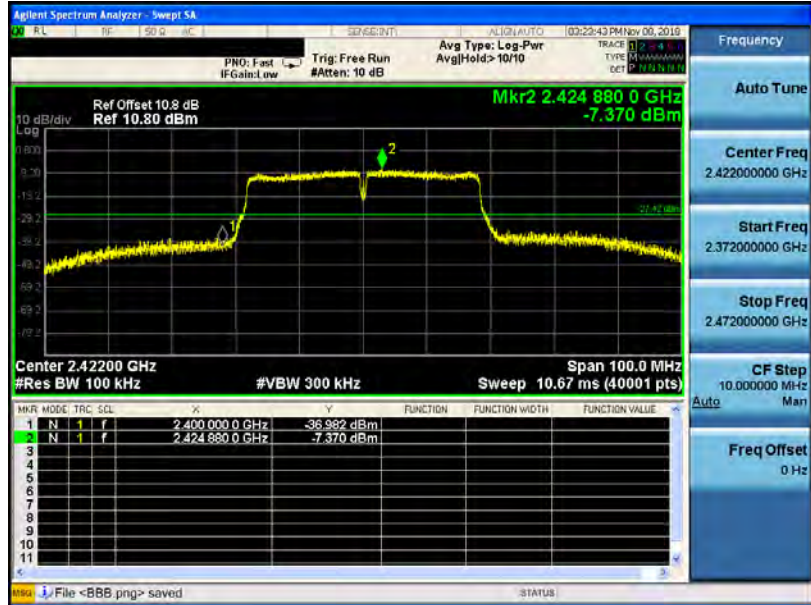

2452 MHz

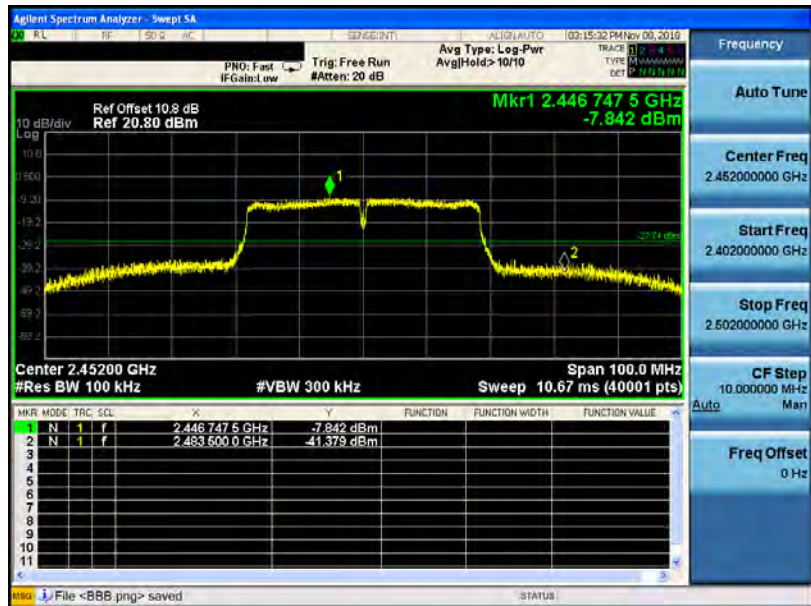



Power setting 2_Antenna Type: Heavy Duty Screw Mount Antenna

Maximum Conducted Output Power Measurement

Test Mode	Frequency (MHz)	RF Power setting in Test Software	Test Software Version
Mode 2	2412	18.0	Terminal
	2437	18.0	
	2462	17.0	
Mode 3	2412	11.0	
	2437	22.0	
	2462	9.0	
Mode 4	2412	10.0	
	2437	22.0	
	2462	8.0	
Mode 5	2422	6.0	
	2437	9.0	
	2452	6.0	

Test Mode	Data Rate (Mbps)	Frequency (MHz)	Average Output Power		Peak Output Power		
			Measurement Results		Measurement Results		Limit
			dBm	W	dBm	W	dBm
Mode 2	1	2412	14.39	0.027	16.99	0.050	≤ 30
		2437	16.17	0.041	18.30	0.068	≤ 30
		2462	15.57	0.036	17.63	0.058	≤ 30
	2	2437	16.16	0.041	18.28	0.067	≤ 30
	5.5	2437	16.15	0.041	18.27	0.067	≤ 30
	11	2437	16.12	0.041	18.26	0.067	≤ 30
Mode 3	6	2412	7.44	0.006	14.18	0.026	≤ 30
		2437	17.04	0.051	21.65	0.146	≤ 30
		2462	7.20	0.005	13.92	0.025	≤ 30
	9	2437	17.03	0.050	21.58	0.144	≤ 30
	12	2437	17.01	0.050	21.56	0.143	≤ 30
	18	2437	17.00	0.050	21.54	0.143	≤ 30
	24	2437	16.99	0.050	21.53	0.142	≤ 30
	36	2437	16.97	0.050	21.52	0.142	≤ 30
	48	2437	16.96	0.050	21.50	0.141	≤ 30
	54	2437	16.94	0.049	21.49	0.141	≤ 30

Note: The relevant measured result has the offset with cable loss already.



Test Mode	Data Rate (Mbps)	Frequency (MHz)	Average Output Power		Peak Output Power		
			Measurement Results		Measurement Results		Limit
			dBm	W	dBm	W	dBm
Mode 4	6.5M	2412	7.56	0.006	14.26	0.027	≤ 30
		2437	17.38	0.055	22.04	0.160	≤ 30
		2462	6.56	0.005	13.26	0.021	≤ 30
	14.4M	2437	17.36	0.054	21.96	0.157	≤ 30
	21.7M	2437	17.34	0.054	21.95	0.157	≤ 30
	28.9M	2437	17.33	0.054	21.93	0.156	≤ 30
	43.3M	2437	17.32	0.054	21.92	0.156	≤ 30
	57.8M	2437	17.30	0.054	21.90	0.155	≤ 30
	65M	2437	17.29	0.054	21.89	0.155	≤ 30
	72.2M	2437	17.28	0.053	21.88	0.154	≤ 30
Mode 5	13.5M	2422	3.73	0.002	10.47	0.011	≤ 30
		2437	8.05	0.006	14.77	0.030	≤ 30
		2452	5.12	0.003	11.86	0.015	≤ 30
	30M	2437	8.02	0.006	14.56	0.029	≤ 30
	45M	2437	8.00	0.006	14.54	0.028	≤ 30
	60M	2437	7.99	0.006	14.51	0.028	≤ 30
	90M	2437	7.98	0.006	14.50	0.028	≤ 30
	120M	2437	7.96	0.006	14.48	0.028	≤ 30
	135M	2437	7.95	0.006	14.47	0.028	≤ 30
	150M	2437	7.94	0.006	14.45	0.028	≤ 30

Note: The relevant measured result has the offset with cable loss already.

**6 dB RF Bandwidth Measurement**

Test Mode	Frequency (MHz)	Measurement (kHz)	Limit (kHz)
Mode 2	2412	9077	≥ 500
	2437	9076	≥ 500
	2462	9069	≥ 500
Mode 3	2412	16560	≥ 500
	2437	16570	≥ 500
	2462	16570	≥ 500
Mode 4	2412	17730	≥ 500
	2437	17660	≥ 500
	2462	17780	≥ 500
Mode 5	2422	36420	≥ 500
	2437	36400	≥ 500
	2452	36420	≥ 500

■ Test Graphs

Mode 2: IEEE 802.11b Continuous TX mode	
2412 MHz	<p>Center Freq 2.41200000 GHz</p> <p>Center Freq: 2.412000000 GHz</p> <p>Trig: Free Run #Attenu: 20 dB</p> <p>Radio Std: None</p> <p>Radio Device: BTS</p> <p>Ref 10.80 dBm</p> <p>Center 2.412 GHz #Res BW 100 kHz #VBW 300 kHz Span 30 MHz Sweep 2.933 ms</p> <p>Occupied Bandwidth 14.372 MHz Total Power 21.5 dBm</p> <p>Transmit Freq Error 126.80 kHz % of OBW Power 99.00 %</p> <p>x dB Bandwidth 9.077 MHz x dB -6.00 dB</p> <p>Center Freq 2.41200000 GHz</p> <p>CF Step 3.000000 MHz</p> <p>Freq Offset 0 Hz</p>
2437 MHz	<p>Center Freq 2.43700000 GHz</p> <p>Center Freq: 2.437000000 GHz</p> <p>Trig: Free Run #Attenu: 20 dB</p> <p>Radio Std: None</p> <p>Radio Device: BTS</p> <p>Ref 10.80 dBm</p> <p>Center 2.437 GHz #Res BW 100 kHz #VBW 300 kHz Span 30 MHz Sweep 2.933 ms</p> <p>Occupied Bandwidth 14.438 MHz Total Power 22.4 dBm</p> <p>Transmit Freq Error 135.21 kHz % of OBW Power 99.00 %</p> <p>x dB Bandwidth 9.076 MHz x dB -6.00 dB</p> <p>Center Freq 2.43700000 GHz</p> <p>CF Step 3.000000 MHz</p> <p>Freq Offset 0 Hz</p>
2462 MHz	<p>Center Freq 2.46200000 GHz</p> <p>Center Freq: 2.462000000 GHz</p> <p>Trig: Free Run #Attenu: 20 dB</p> <p>Radio Std: None</p> <p>Radio Device: BTS</p> <p>Ref 10.80 dBm</p> <p>Center 2.462 GHz #Res BW 100 kHz #VBW 300 kHz Span 30 MHz Sweep 2.933 ms</p> <p>Occupied Bandwidth 14.196 MHz Total Power 22.2 dBm</p> <p>Transmit Freq Error 44.100 kHz % of OBW Power 99.00 %</p> <p>x dB Bandwidth 9.069 MHz x dB -6.00 dB</p> <p>Center Freq 2.46200000 GHz</p> <p>CF Step 3.000000 MHz</p> <p>Freq Offset 0 Hz</p>

Mode 3: IEEE 802.11g Continuous TX mode

<p>2412 MHz</p>	<p>Center Freq 2.412000000 GHz</p> <p>Center Freq 2.412000000 GHz</p> <p>Center Freq 2.412 GHz</p> <p>Res BW 100 kHz</p> <p>VBW 300 kHz</p> <p>Span 30 MHz</p> <p>Sweep 2.933 ms</p> <p>Ref 10.80 dBm</p> <p>Occupied Bandwidth 17.192 MHz</p> <p>Total Power 15.0 dBm</p> <p>Transmit Freq Error 125.26 kHz</p> <p>% of OBW Power 99.00 %</p> <p>x dB Bandwidth 16.56 MHz</p> <p>x dB -6.00 dB</p>
<p>2437 MHz</p>	<p>Center Freq 2.437000000 GHz</p> <p>Center Freq 2.437000000 GHz</p> <p>Center Freq 2.437 GHz</p> <p>Res BW 100 kHz</p> <p>VBW 300 kHz</p> <p>Span 30 MHz</p> <p>Sweep 2.933 ms</p> <p>Ref 10.80 dBm</p> <p>Occupied Bandwidth 20.291 MHz</p> <p>Total Power 24.1 dBm</p> <p>Transmit Freq Error 1.3194 MHz</p> <p>% of OBW Power 99.00 %</p> <p>x dB Bandwidth 16.57 MHz</p> <p>x dB -6.00 dB</p>
<p>2462 MHz</p>	<p>Center Freq 2.462000000 GHz</p> <p>Center Freq 2.462000000 GHz</p> <p>Center Freq 2.462 GHz</p> <p>Res BW 100 kHz</p> <p>VBW 300 kHz</p> <p>Span 30 MHz</p> <p>Sweep 2.933 ms</p> <p>Ref 10.80 dBm</p> <p>Occupied Bandwidth 17.198 MHz</p> <p>Total Power 14.6 dBm</p> <p>Transmit Freq Error 37.171 kHz</p> <p>% of OBW Power 99.00 %</p> <p>x dB Bandwidth 16.57 MHz</p> <p>x dB -6.00 dB</p>

Mode 4: IEEE 802.11n 2.4 GHz 20 MHz Continuous TX mode

<p>2412 MHz</p>	<p>Center Freq 2.41200000 GHz</p> <p>Center Freq 2.412000000 GHz</p> <p>Center Freq 2.412 GHz</p> <p>Res BW 100 kHz</p> <p>Span 30 MHz</p> <p>Sweep 2.933 ms</p> <p>Occupied Bandwidth 17.818 MHz</p> <p>Total Power 14.3 dBm</p> <p>Transmit Freq Error 44.814 kHz</p> <p>% of OBW Power 99.00 %</p> <p>x dB Bandwidth 17.73 MHz</p> <p>x dB -6.00 dB</p>
<p>2437 MHz</p>	<p>Center Freq 2.43700000 GHz</p> <p>Center Freq 2.437000000 GHz</p> <p>Center Freq 2.437 GHz</p> <p>Res BW 100 kHz</p> <p>Span 30 MHz</p> <p>Sweep 2.933 ms</p> <p>Occupied Bandwidth 20.735 MHz</p> <p>Total Power 24.5 dBm</p> <p>Transmit Freq Error 1.3669 MHz</p> <p>% of OBW Power 99.00 %</p> <p>x dB Bandwidth 17.66 MHz</p> <p>x dB -6.00 dB</p>
<p>2462 MHz</p>	<p>Center Freq 2.46200000 GHz</p> <p>Center Freq 2.462000000 GHz</p> <p>Center Freq 2.462 GHz</p> <p>Res BW 100 kHz</p> <p>Span 30 MHz</p> <p>Sweep 2.933 ms</p> <p>Occupied Bandwidth 17.800 MHz</p> <p>Total Power 13.6 dBm</p> <p>Transmit Freq Error 2.364 kHz</p> <p>% of OBW Power 99.00 %</p> <p>x dB Bandwidth 17.76 MHz</p> <p>x dB -6.00 dB</p>



Mode 5: IEEE 802.11n 2.4 GHz 40 MHz Continuous TX mode

2422 MHz



2437 MHz



2452 MHz



**Maximum Power Spectral Density Measurement**

Test Mode	Frequency (MHz)	Measurement (dBm/3 kHz)	Limit (dBm/3 kHz)
Mode 2	2412	-9.576	≤ 8
	2437	-8.436	≤ 8
	2462	-8.641	≤ 8
Mode 3	2412	-17.277	≤ 8
	2437	-7.558	≤ 8
	2462	-17.590	≤ 8
Mode 4	2412	-17.216	≤ 8
	2437	-7.803	≤ 8
	2462	-17.917	≤ 8
Mode 5	2422	-22.355	≤ 8
	2437	-17.360	≤ 8
	2452	-20.908	≤ 8

■ Test Graphs

Mode 2: IEEE 802.11b Continuous TX mode	
2412 MHz	<p>Center Freq 2.41200000 GHz Mkr1 2.412 812 GHz -9.576 dBm Center 2.412000 GHz #Res BW 3.0 kHz #VBW 10 kHz Sweep 31.87 ms (1001 pts)</p>
2437 MHz	<p>Center Freq 2.43700000 GHz Mkr1 2.437 812 GHz -8.436 dBm Center 2.437000 GHz #Res BW 3.0 kHz #VBW 10 kHz Sweep 31.87 ms (1001 pts)</p>
2462 MHz	<p>Center Freq 2.46200000 GHz Mkr1 2.462 812 GHz -8.641 dBm Center 2.462000 GHz #Res BW 3.0 kHz #VBW 10 kHz Sweep 31.87 ms (1001 pts)</p>

Mode 3: IEEE 802.11g Continuous TX mode

2412 MHz

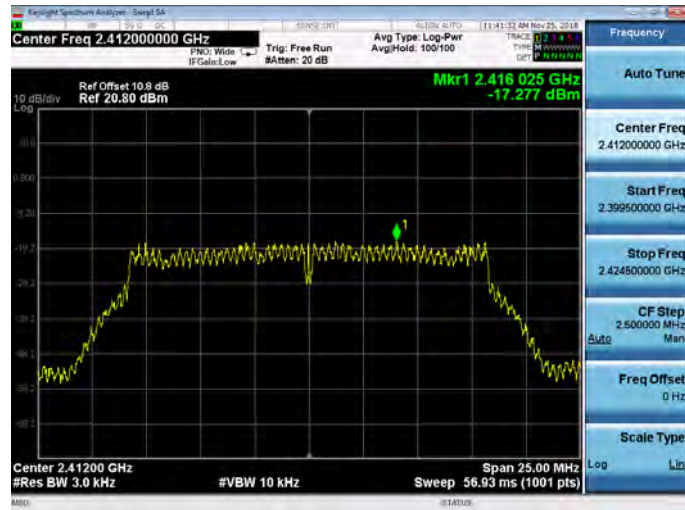

2437 MHz

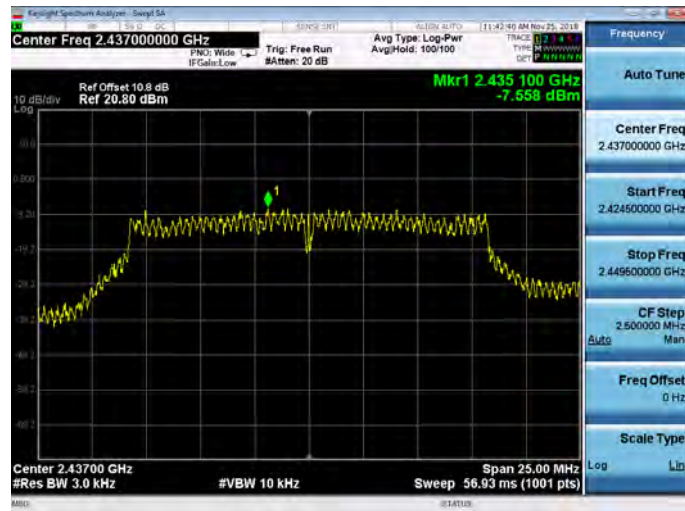

2462 MHz

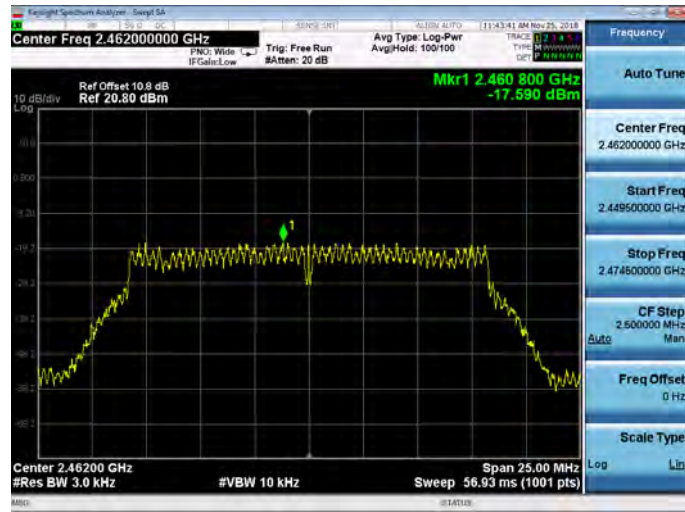

Mode 4: IEEE 802.11n 2.4 GHz 20 MHz Continuous TX mode

2412 MHz

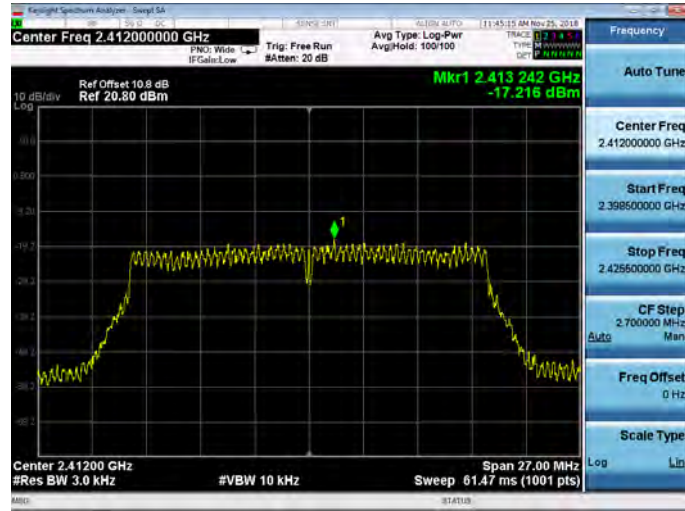

2437 MHz

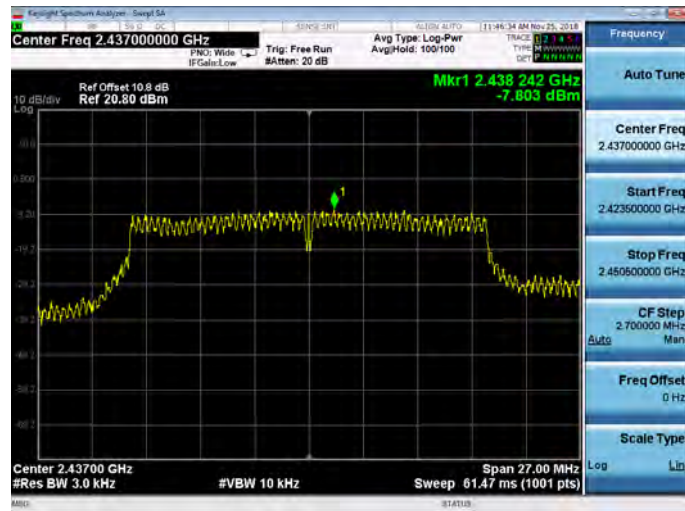

2462 MHz

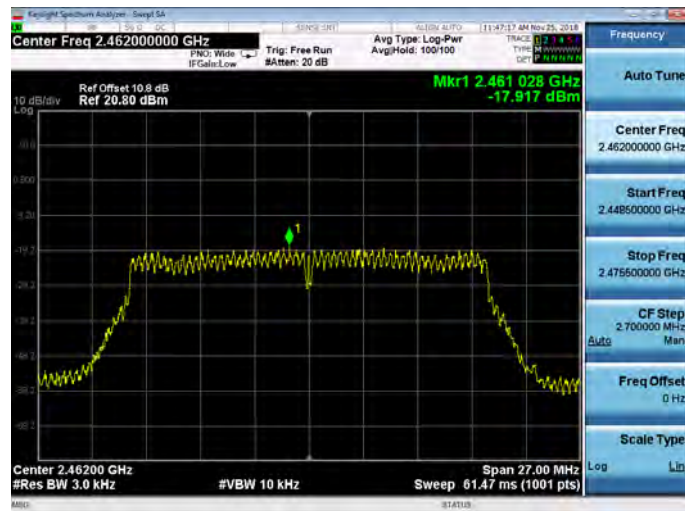

Mode 5: IEEE 802.11n 2.4 GHz 40 MHz Continuous TX mode

2422 MHz

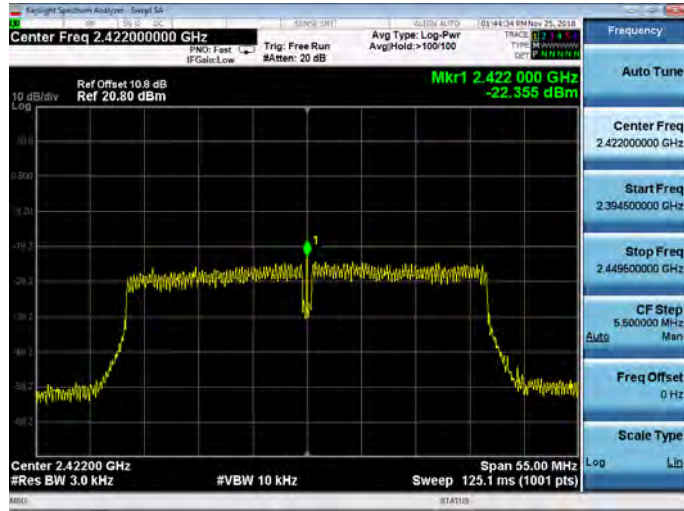

2437 MHz

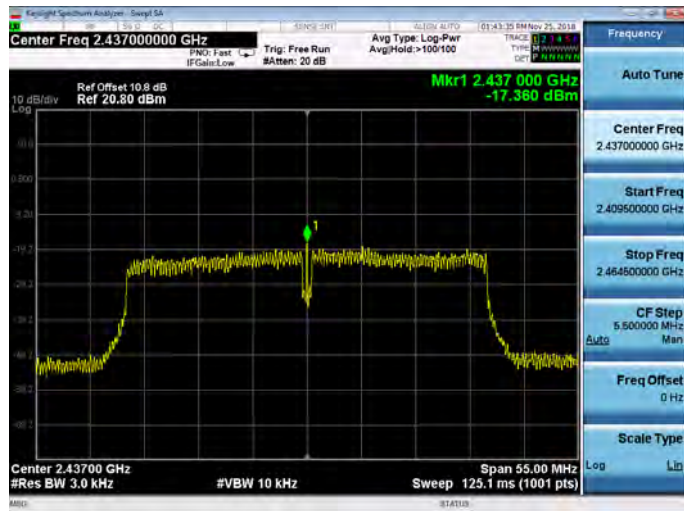

2452 MHz

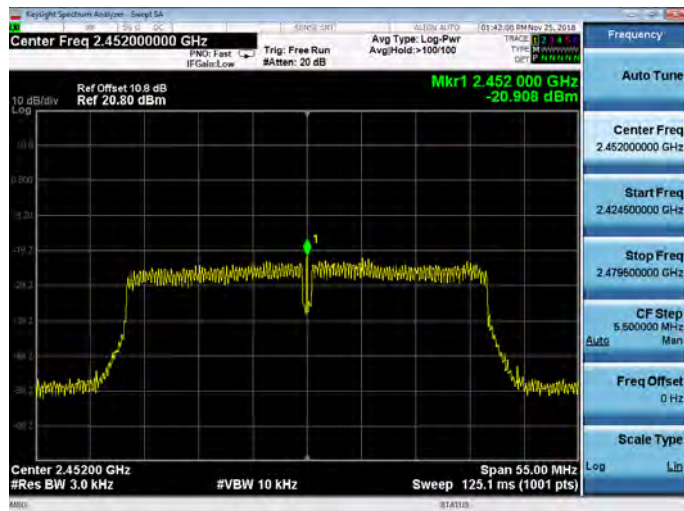

Out of Band Conducted Emissions Measurement

■ Test Graphs

Reference level

Mode 2: IEEE 802.11b Continuous TX mode

<p>2412 MHz</p>	
<p>2437 MHz</p>	
<p>2462 MHz</p>	

Mode 3: IEEE 802.11g Continuous TX mode

2412 MHz

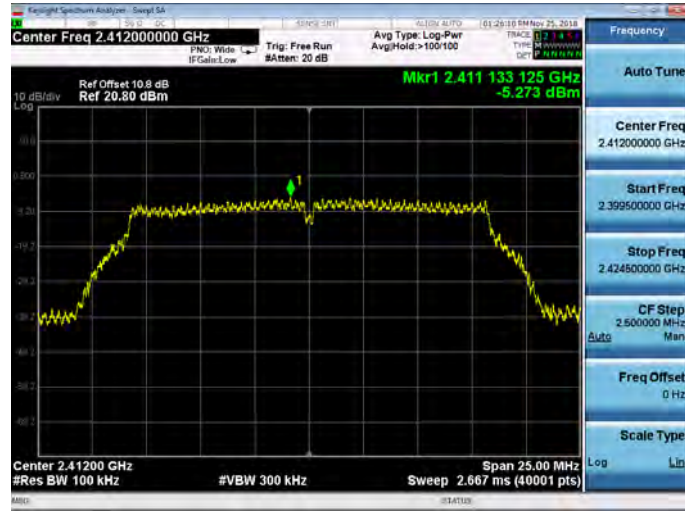

2437 MHz

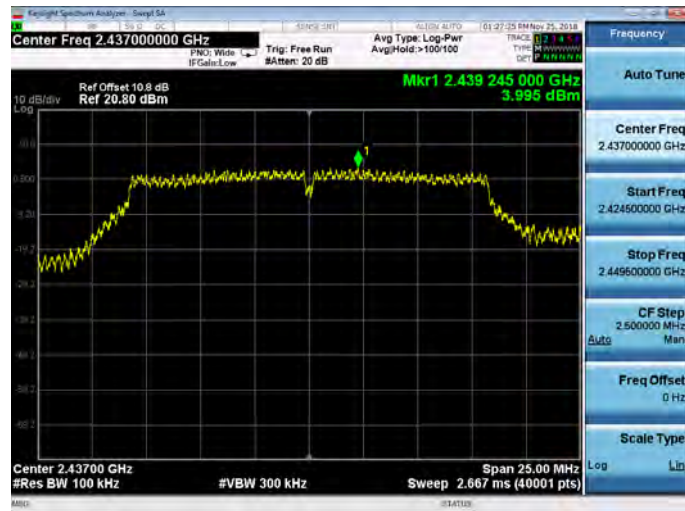

2462 MHz

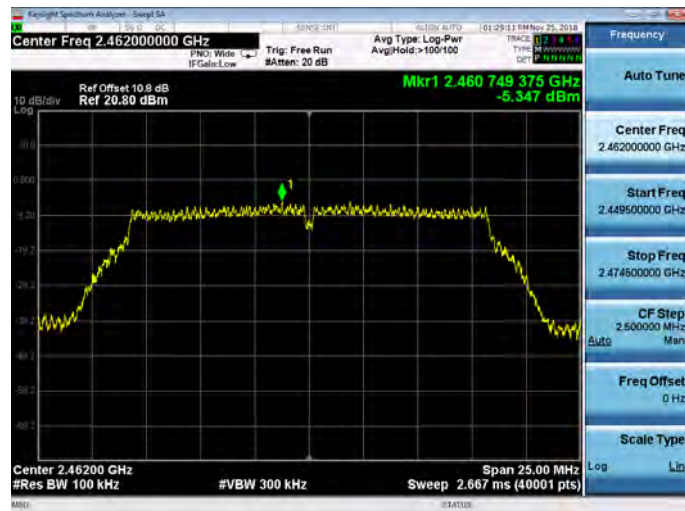



Mode 4: IEEE 802.11n 2.4 GHz 20 MHz Continuous TX mode

2412 MHz

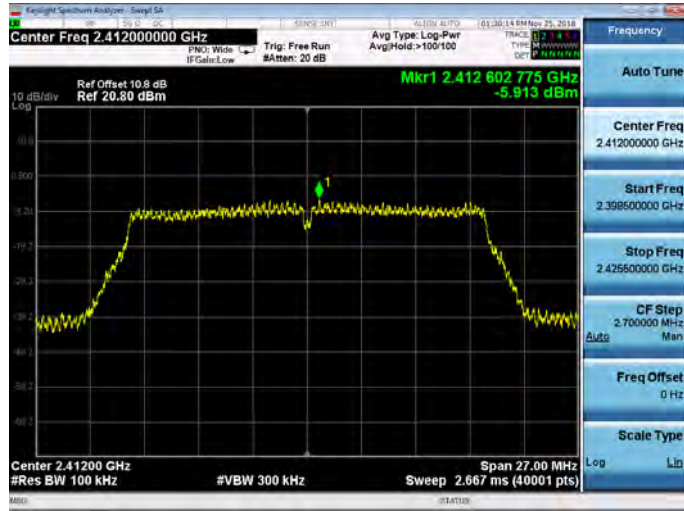

2437 MHz

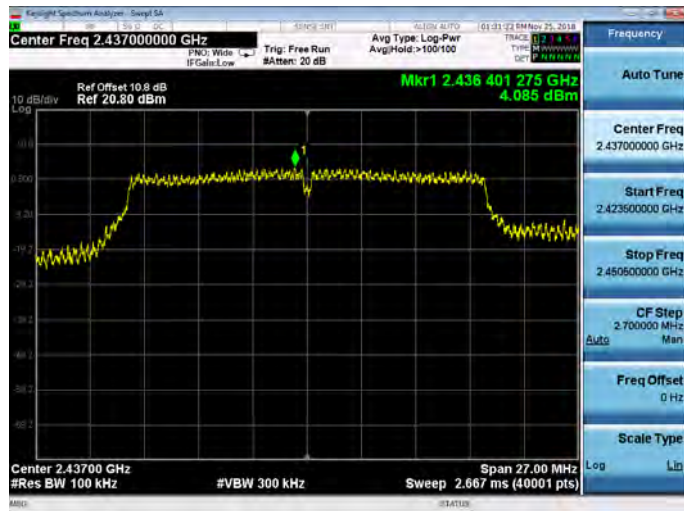

2462 MHz

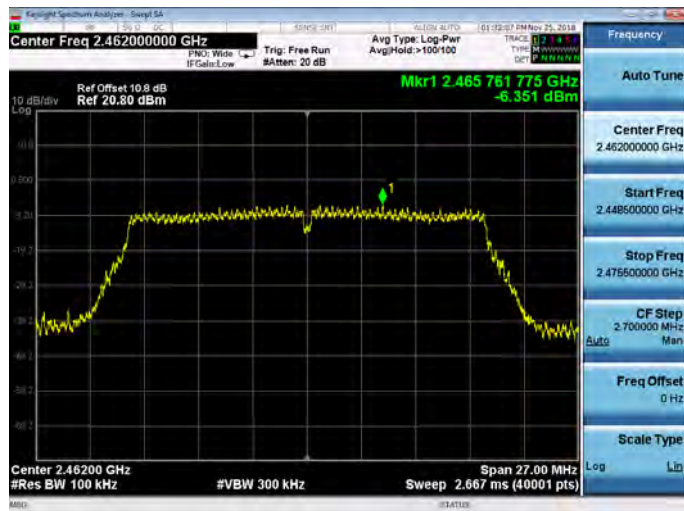

Mode 5: IEEE 802.11n 2.4 GHz 40 MHz Continuous TX mode

2422 MHz

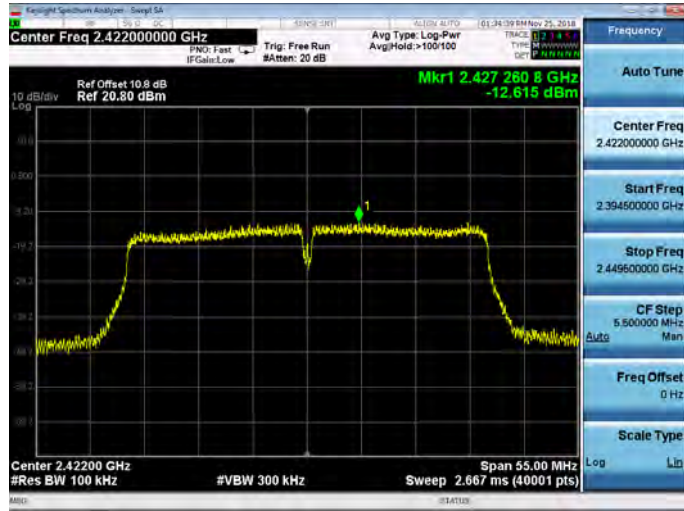

2437 MHz

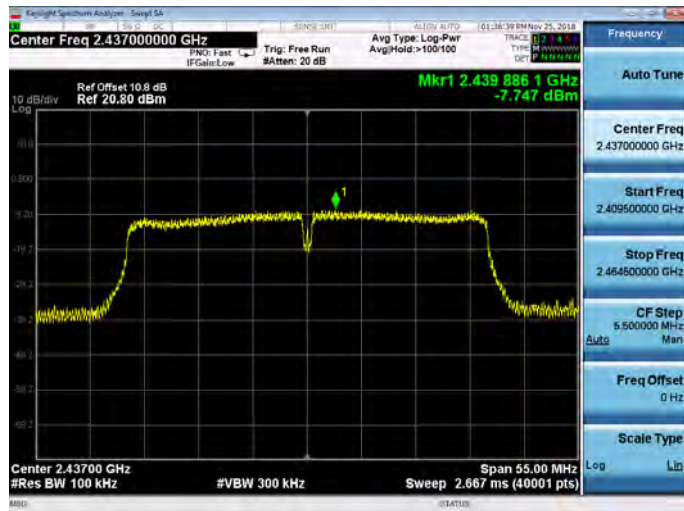

2452 MHz

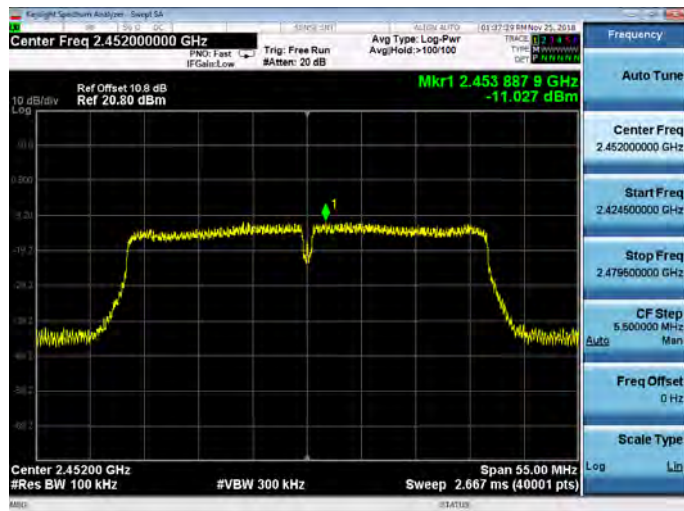



Out of Band Conducted Emissions

Mode 2: IEEE 802.11b Continuous TX mode

<p>2412 MHz</p>	
<p>2437 MHz</p>	
<p>2462 MHz</p>	



Mode 3: IEEE 802.11g Continuous TX mode

2412 MHz



2437 MHz

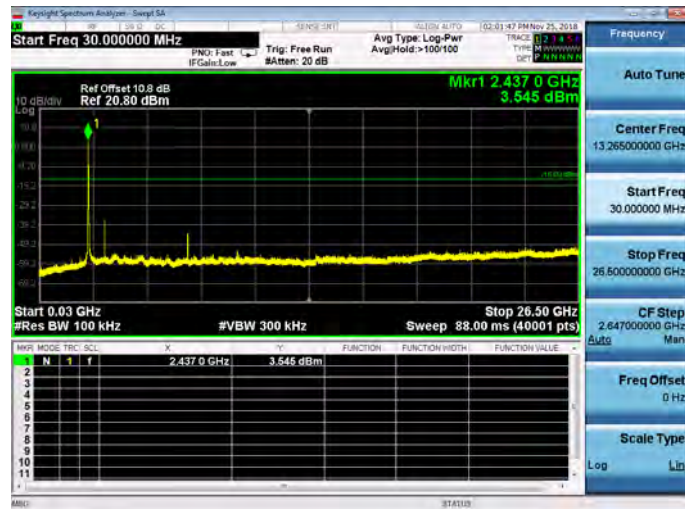

2462 MHz





Mode 4: IEEE 802.11n 2.4 GHz 20 MHz Continuous TX mode

2412 MHz

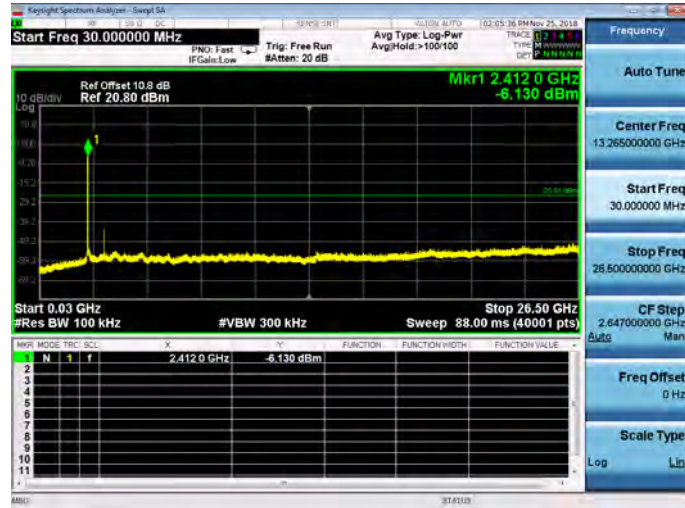

2437 MHz

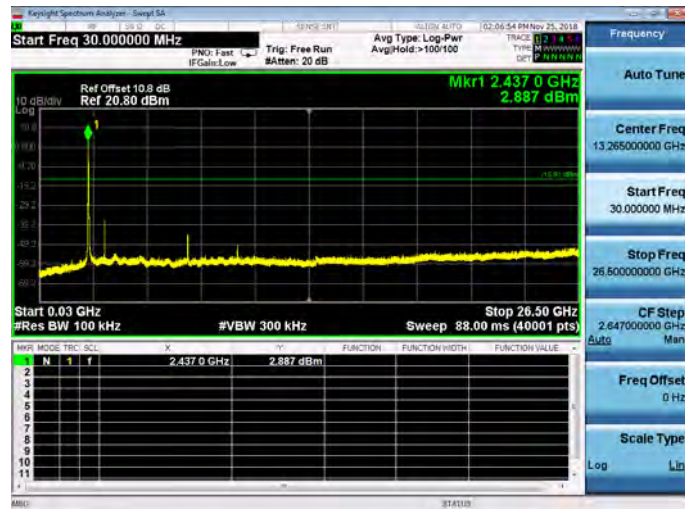

2462 MHz



Mode 5: IEEE 802.11n 2.4 GHz 40 MHz Continuous TX mode

2422 MHz



2437 MHz

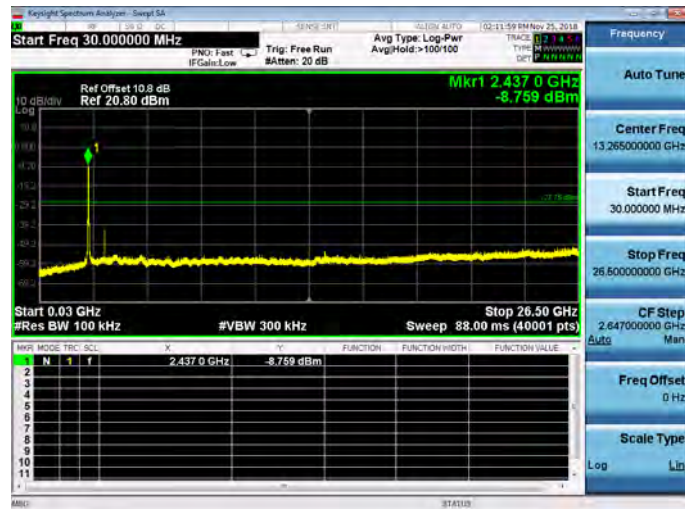

2452 MHz





Conducted Band Edge

Mode 2: IEEE 802.11b Continuous TX mode

2412 MHz



2462 MHz

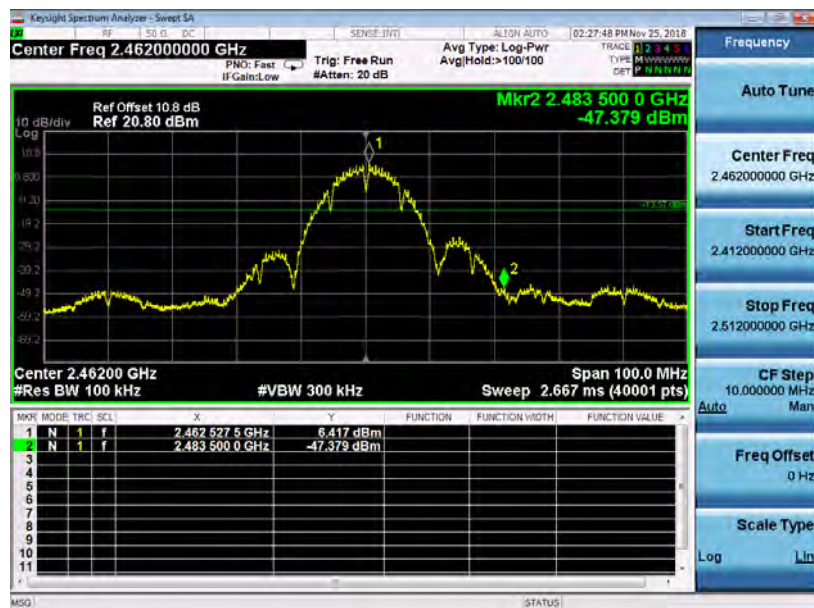

Mode 3: IEEE 802.11g Continuous TX mode

2412 MHz

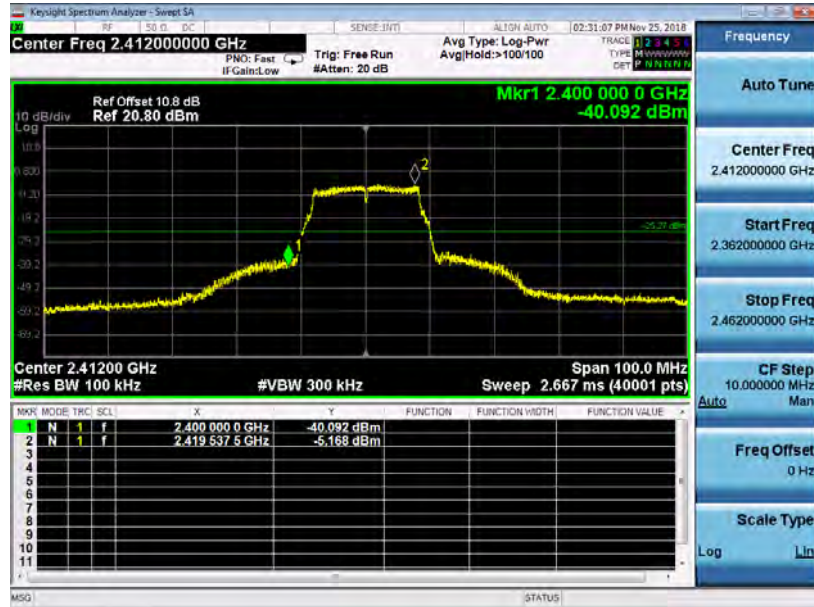

2462 MHz



Mode 4: IEEE 802.11n 2.4 GHz 20 MHz Continuous TX mode

2412 MHz

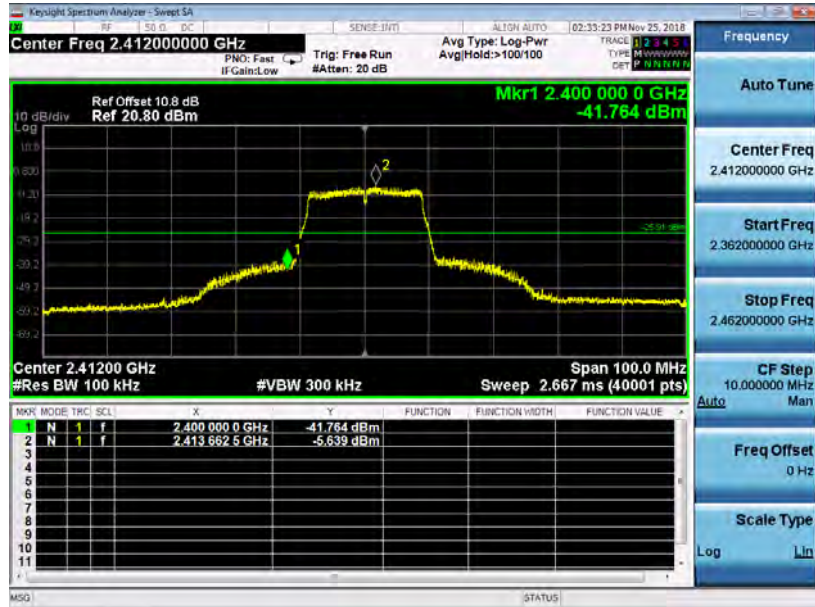

2462 MHz

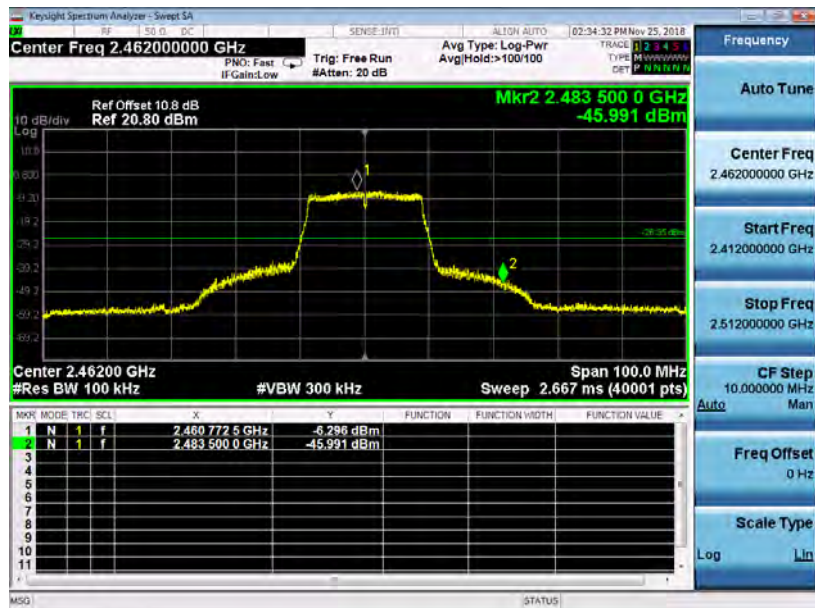

Mode 5: IEEE 802.11n 2.4 GHz 40 MHz Continuous TX mode

2422 MHz

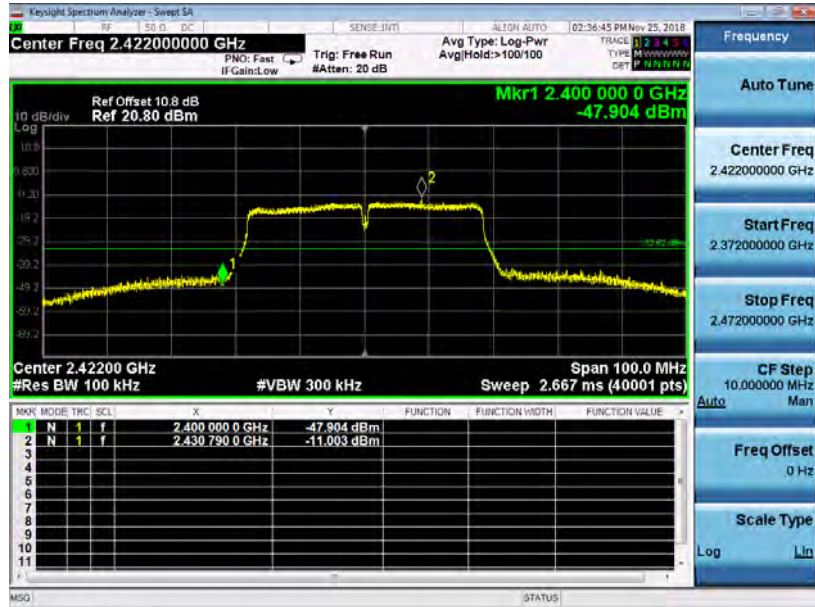

2452 MHz





Annex B. Radiated Emission Test Results

Harmonic

Power setting 1_Antenna Type: PCB Trace Antenna

Below 1 GHz

Standard:	FCC Part 15.247	Test Distance:	3 m				
Test item:	Harmonic	Power:	DC 3.3 V				
Test Mode:	Mode 1	Temp.(°C)/Hum.(%RH):	26(°C)/60 %RH				
Frequency (MHz)	Reading (dBuV)	Correct Factor (dB/m)	Result (dBuV/m)	Limit (dBuV/m)	Margin (dB)	Remark	Ant.Polar. H / V
216.2400	41.52	-8.53	32.99	46.00	-13.01	QP	H
278.3200	39.04	-5.37	33.67	46.00	-12.33	QP	H
346.2200	34.71	-3.98	30.73	46.00	-15.27	QP	H
535.3700	28.90	-0.06	28.84	46.00	-17.16	QP	H
690.5700	28.87	2.97	31.84	46.00	-14.16	QP	H
878.7500	28.73	6.50	35.23	46.00	-10.77	QP	H
165.8000	32.11	-6.50	25.61	43.50	-17.89	QP	V
232.7300	35.73	-7.66	28.07	46.00	-17.93	QP	V
312.2700	33.33	-4.50	28.83	46.00	-17.17	QP	V
452.9200	32.74	-1.44	31.30	46.00	-14.70	QP	V
675.0500	29.49	2.65	32.14	46.00	-13.86	QP	V
892.3300	28.47	6.73	35.20	46.00	-10.80	QP	V

Note:1.Result (dBuV/m) = Correct Factor (dB/m) + Reading(dBuV).

Example: 32.99= -8.53+41.52

2.Correction factor (dB/m) = Antenna Factor (dB/m) + Cable loss (dB) – Pre-Amplifier gain (dB).

3.When the peak results are less than average limit, so not need to evaluate the average.



Above 1 GHz

Standard:	FCC Part 15.247	Test Distance:	3 m
Test item:	Harmonic	Power:	DC 3.3 V
Frequency:	2412 MHz	Temp.(°C)/Hum.(%RH):	26(°C)/60 %RH
Mode:	Mode 2		
Ant.Polar.:	Horizontal		

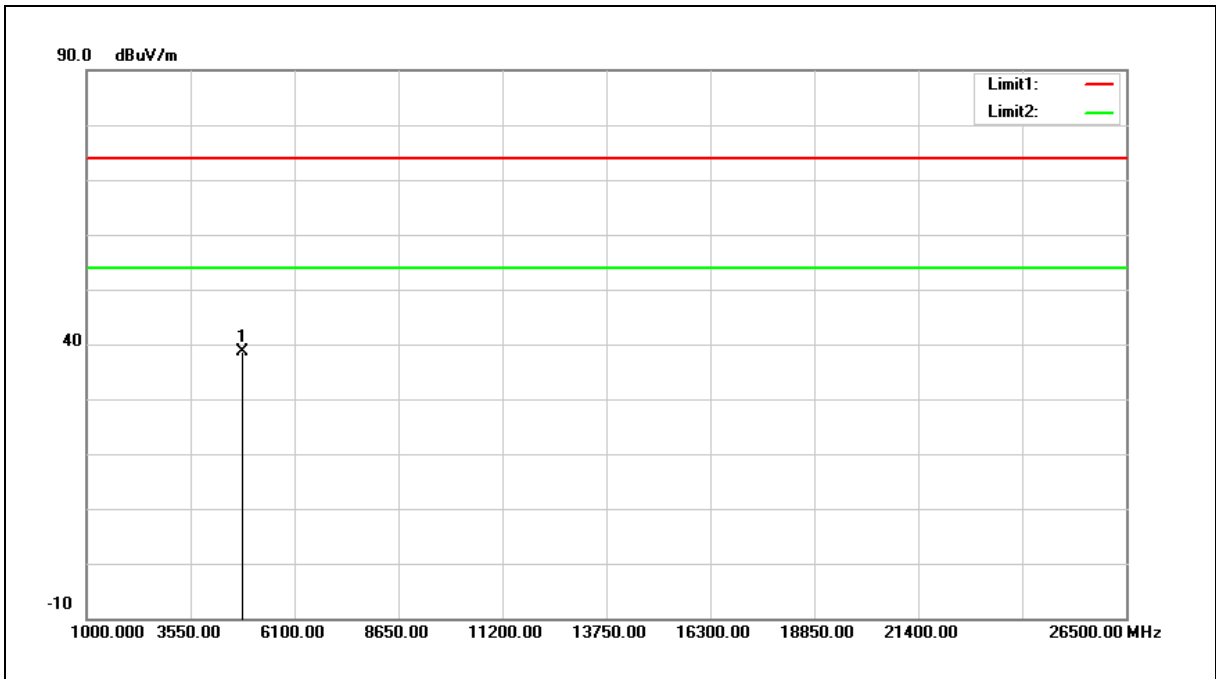

No.	Frequency (MHz)	Reading (dBuV)	Correct Factor (dB/m)	Result (dBuV/m)	Limit (dBuV/m)	Margin (dB)	Remark
1	4824.000	31.28	7.32	38.60	74.00	-35.40	peak

Note:1.Result (dBuV/m) = Correct Factor (dB/m) + Reading(dBuV).

Example: 38.60= 7.32+31.28

2.Correction factor (dB/m) = Antenna Factor (dB/m) + Cable loss (dB) – Pre-Amplifier gain (dB).

3.When the peak results are less than average limit, so not need to evaluate the average.



Standard:	FCC Part 15.247	Test Distance:	3 m
Test item:	Harmonic	Power:	DC 3.3 V
Frequency:	2412 MHz	Temp.(°C)/Hum.(%RH):	26(°C)/60 %RH
Mode:	Mode 2		
Ant.Polar.:	Vertical		

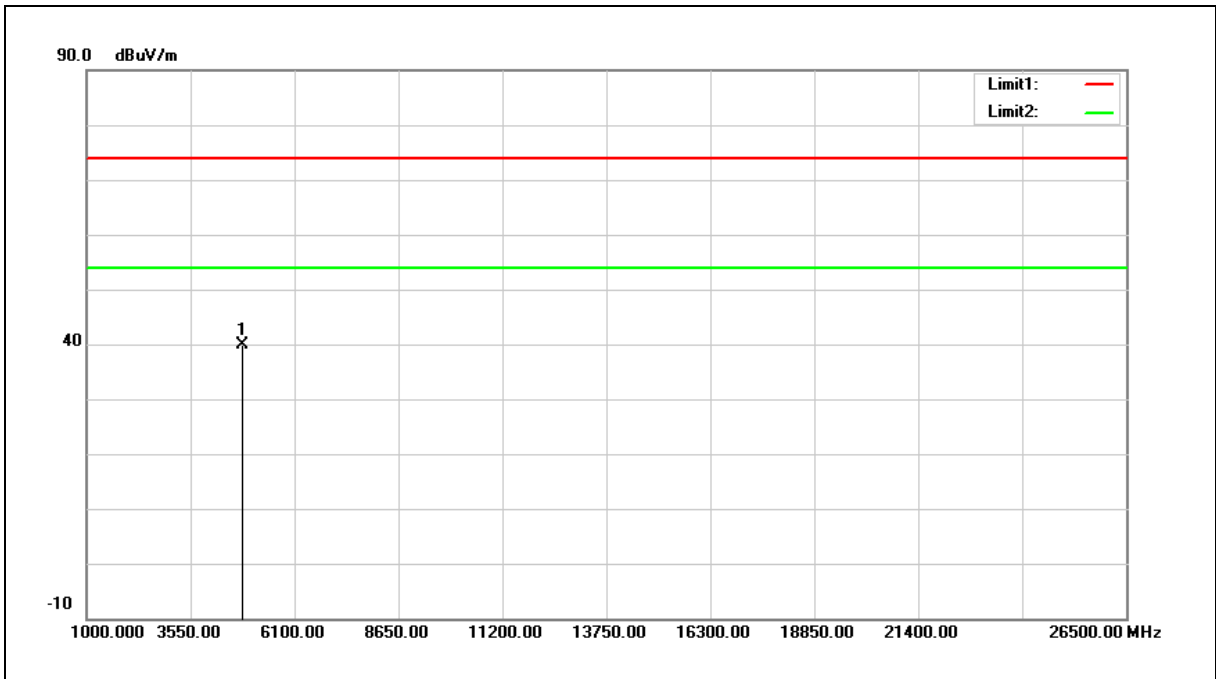

No.	Frequency (MHz)	Reading (dBuV)	Correct Factor (dB/m)	Result (dBuV/m)	Limit (dBuV/m)	Margin (dB)	Remark
1	4824.000	32.63	7.32	39.95	74.00	-34.05	peak

Note:1.Result (dBuV/m) = Correct Factor (dB/m) + Reading(dBuV).

Example: 39.95= 7.32+32.63

2.Correction factor (dB/m) = Antenna Factor (dB/m) + Cable loss (dB) – Pre-Amplifier gain (dB).

3.When the peak results are less than average limit, so not need to evaluate the average.



Standard:	FCC Part 15.247	Test Distance:	3 m
Test item:	Harmonic	Power:	DC 3.3 V
Frequency:	2437 MHz	Temp.(°C)/Hum.(%RH):	26(°C)/60 %RH
Mode:	Mode 2		
Ant.Polar.:	Horizontal		

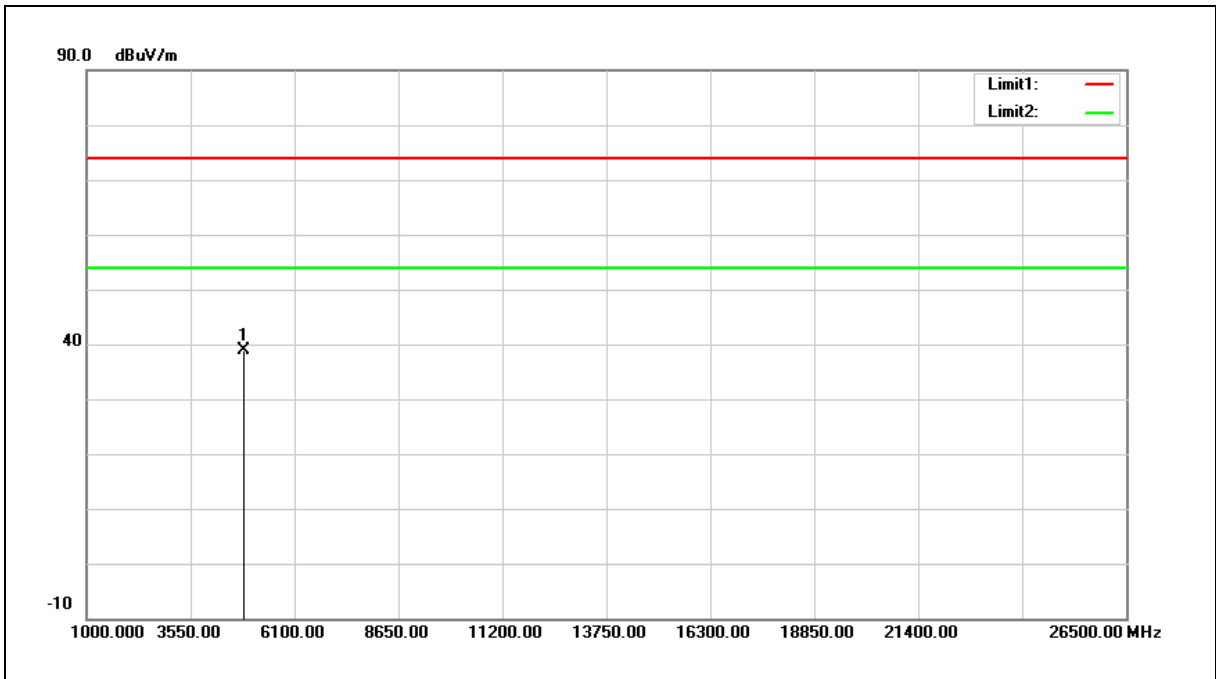

No.	Frequency (MHz)	Reading (dBuV)	Correct Factor (dB/m)	Result (dBuV/m)	Limit (dBuV/m)	Margin (dB)	Remark
1	4874.000	31.47	7.39	38.86	74.00	-35.14	peak

Note:1.Result (dBuV/m) = Correct Factor (dB/m) + Reading(dBuV).

2.Correction factor (dB/m) = Antenna Factor (dB/m) + Cable loss (dB) – Pre-Amplifier gain (dB).

3.When the peak results are less than average limit, so not need to evaluate the average.



Standard:	FCC Part 15.247	Test Distance:	3 m
Test item:	Harmonic	Power:	DC 3.3 V
Frequency:	2437 MHz	Temp.(°C)/Hum.(%RH):	26(°C)/60 %RH
Mode:	Mode 2		
Ant.Polar.:	Vertical		

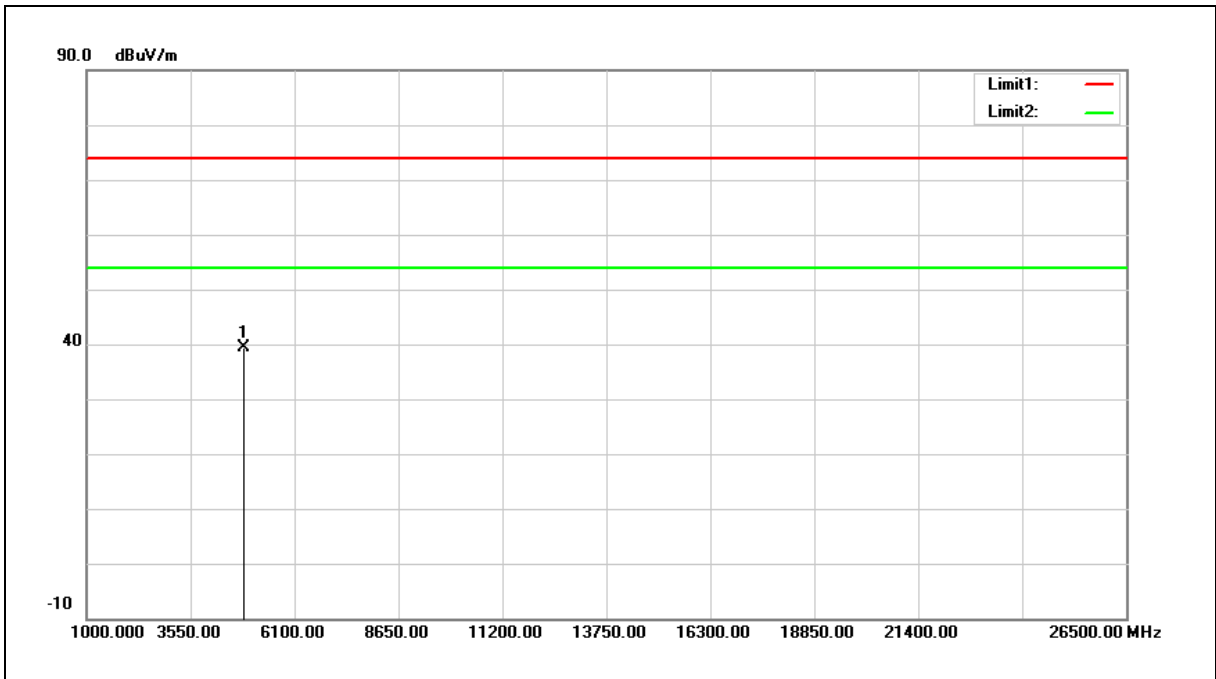

No.	Frequency (MHz)	Reading (dBuV)	Correct Factor (dB/m)	Result (dBuV/m)	Limit (dBuV/m)	Margin (dB)	Remark
1	4874.000	31.92	7.39	39.31	74.00	-34.69	peak

Note:1.Result (dBuV/m) = Correct Factor (dB/m) + Reading(dBuV).

2.Correction factor (dB/m) = Antenna Factor (dB/m) + Cable loss (dB) – Pre-Amplifier gain (dB).

3.When the peak results are less than average limit, so not need to evaluate the average.



Standard:	FCC Part 15.247	Test Distance:	3 m
Test item:	Harmonic	Power:	DC 3.3 V
Frequency:	2462 MHz	Temp.(°C)/Hum.(%RH):	26(°C)/60 %RH
Mode:	Mode 2		
Ant.Polar.:	Horizontal		

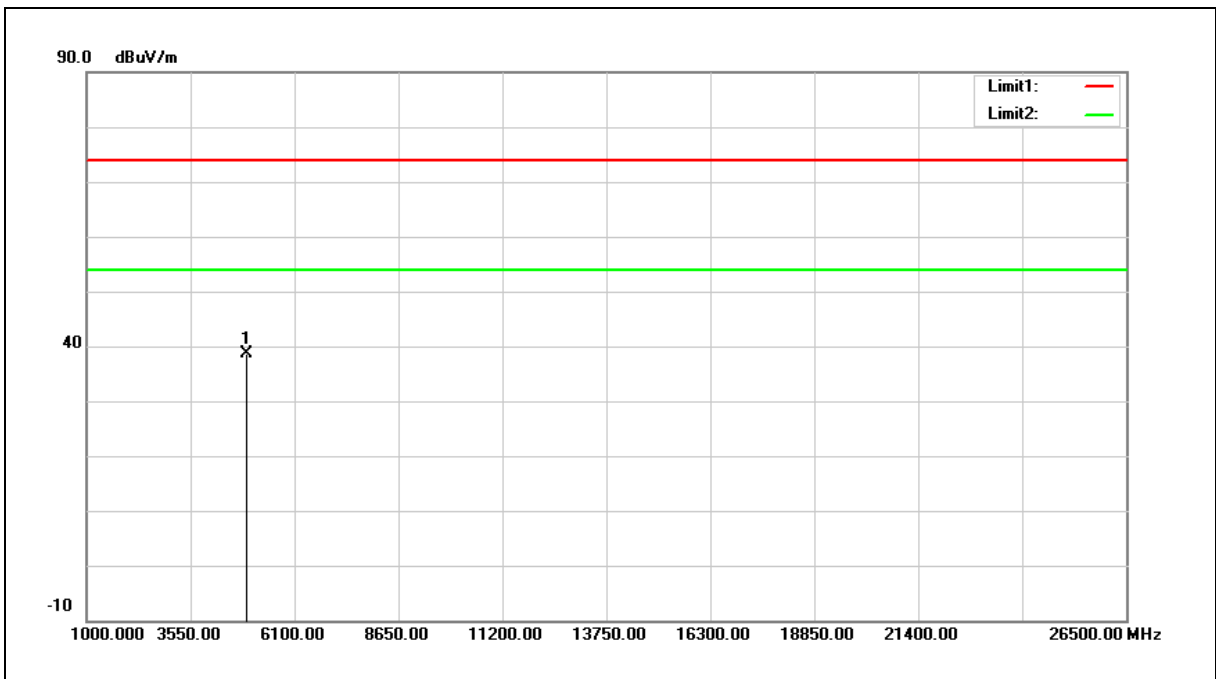

No.	Frequency (MHz)	Reading (dBuV)	Correct Factor (dB/m)	Result (dBuV/m)	Limit (dBuV/m)	Margin (dB)	Remark
1	4924.000	31.19	7.45	38.64	74.00	-35.36	peak

Note:1.Result (dBuV/m) = Correct Factor (dB/m) + Reading(dBuV).

2.Correction factor (dB/m) = Antenna Factor (dB/m) + Cable loss (dB) – Pre-Amplifier gain (dB).

3.When the peak results are less than average limit, so not need to evaluate the average.



Standard:	FCC Part 15.247	Test Distance:	3 m
Test item:	Harmonic	Power:	DC 3.3 V
Frequency:	2462 MHz	Temp.(°C)/Hum.(%RH):	26(°C)/60 %RH
Mode:	Mode 2		
Ant.Polar.:	Vertical		

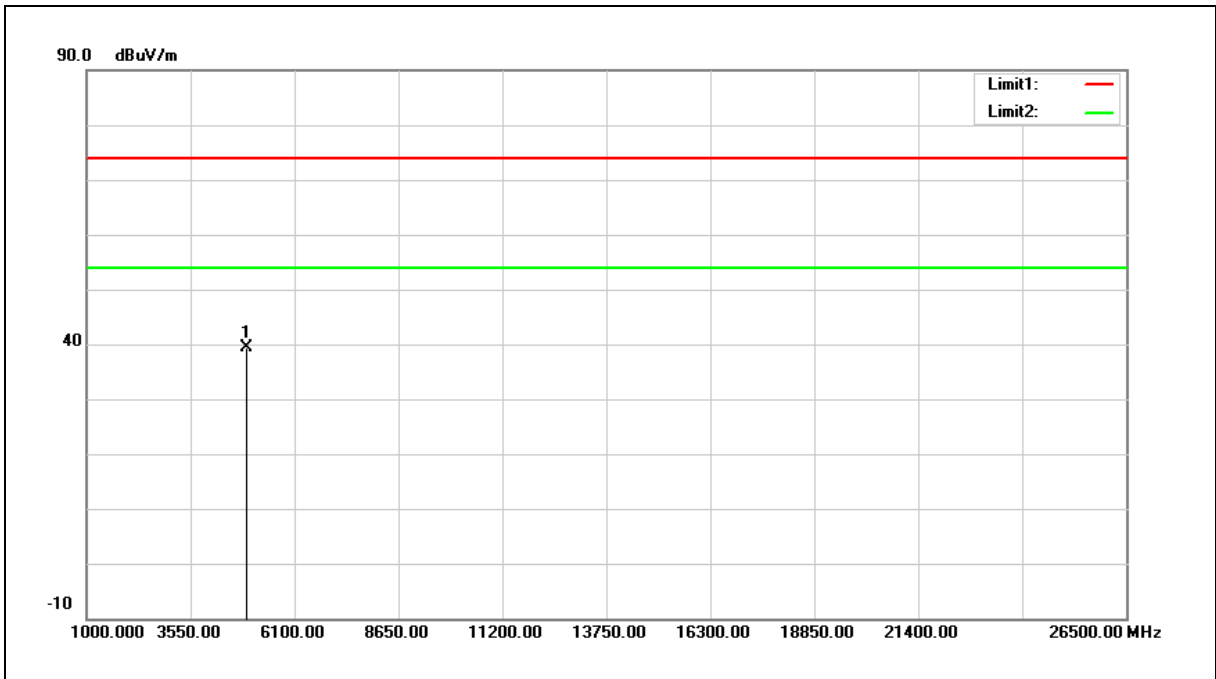

No.	Frequency (MHz)	Reading (dBuV)	Correct Factor (dB/m)	Result (dBuV/m)	Limit (dBuV/m)	Margin (dB)	Remark
1	4924.000	31.92	7.45	39.37	74.00	-34.63	peak

Note:1.Result (dBuV/m) = Correct Factor (dB/m) + Reading(dBuV).

2.Correction factor (dB/m) = Antenna Factor (dB/m) + Cable loss (dB) – Pre-Amplifier gain (dB).

3.When the peak results are less than average limit, so not need to evaluate the average.



Standard:	FCC Part 15.247	Test Distance:	3 m
Test item:	Harmonic	Power:	DC 3.3 V
Frequency:	2412 MHz	Temp.(°C)/Hum.(%RH):	26(°C)/60 %RH
Mode:	Mode 3		
Ant.Polar.:	Horizontal		

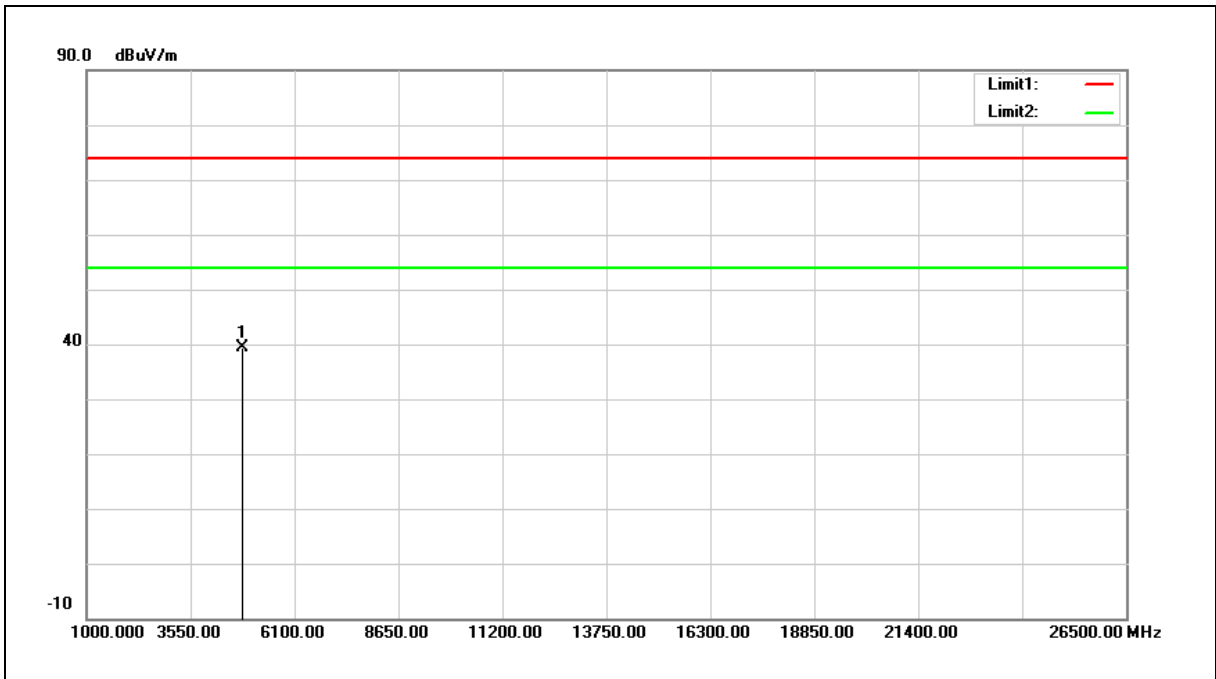

No.	Frequency (MHz)	Reading (dBuV)	Correct Factor (dB/m)	Result (dBuV/m)	Limit (dBuV/m)	Margin (dB)	Remark
1	4824.000	31.98	7.32	39.30	74.00	-34.70	peak

Note:1.Result (dBuV/m) = Correct Factor (dB/m) + Reading(dBuV).

2.Correction factor (dB/m) = Antenna Factor (dB/m) + Cable loss (dB) – Pre-Amplifier gain (dB).

3.When the peak results are less than average limit, so not need to evaluate the average.



Standard:	FCC Part 15.247	Test Distance:	3 m
Test item:	Harmonic	Power:	DC 3.3 V
Frequency:	2412 MHz	Temp.(°C)/Hum.(%RH):	26(°C)/60 %RH
Mode:	Mode 3		
Ant.Polar.:	Vertical		

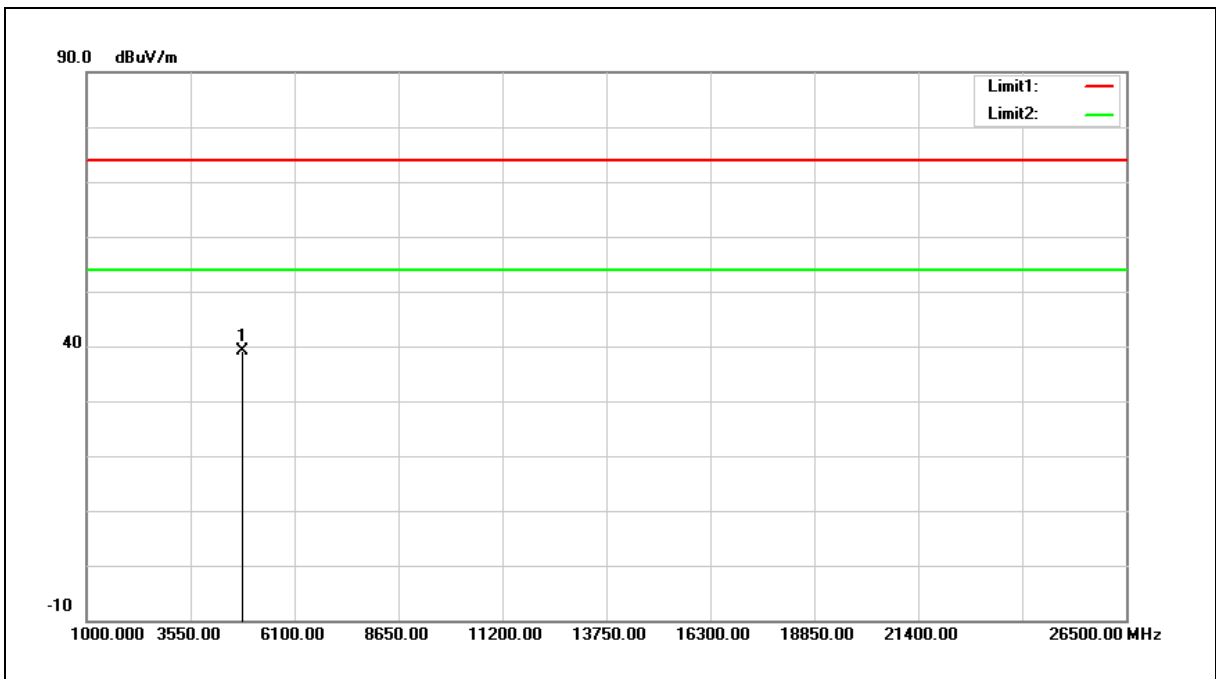

No.	Frequency (MHz)	Reading (dBuV)	Correct Factor (dB/m)	Result (dBuV/m)	Limit (dBuV/m)	Margin (dB)	Remark
1	4824.000	31.93	7.32	39.25	74.00	-34.75	peak

Note:1.Result (dBuV/m) = Correct Factor (dB/m) + Reading(dBuV).

2.Correction factor (dB/m) = Antenna Factor (dB/m) + Cable loss (dB) – Pre-Amplifier gain (dB).

3.When the peak results are less than average limit, so not need to evaluate the average.



Standard:	FCC Part 15.247	Test Distance:	3 m
Test item:	Harmonic	Power:	DC 3.3 V
Frequency:	2437 MHz	Temp.(°C)/Hum.(%RH):	26(°C)/60 %RH
Mode:	Mode 3		
Ant.Polar.:	Horizontal		

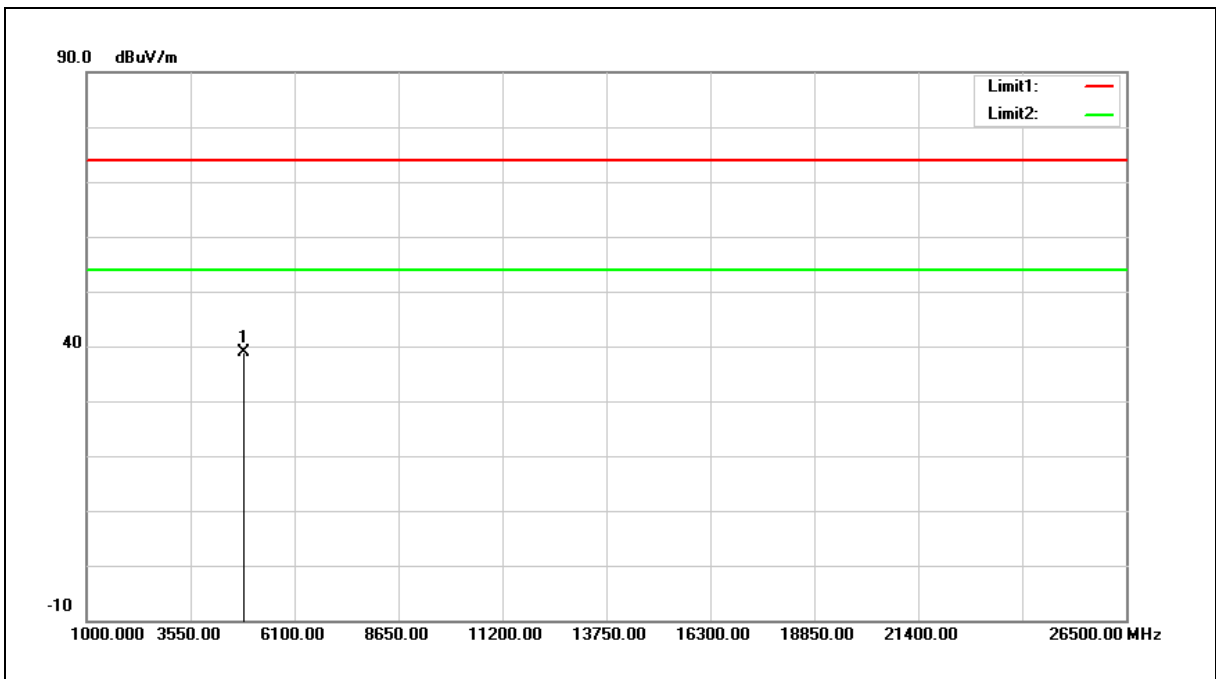

No.	Frequency (MHz)	Reading (dBuV)	Correct Factor (dB/m)	Result (dBuV/m)	Limit (dBuV/m)	Margin (dB)	Remark
1	4874.000	31.60	7.39	38.99	74.00	-35.01	peak

Note:1.Result (dBuV/m) = Correct Factor (dB/m) + Reading(dBuV).

2.Correction factor (dB/m) = Antenna Factor (dB/m) + Cable loss (dB) – Pre-Amplifier gain (dB).

3.When the peak results are less than average limit, so not need to evaluate the average.



Standard:	FCC Part 15.247	Test Distance:	3 m
Test item:	Harmonic	Power:	DC 3.3 V
Frequency:	2437 MHz	Temp.(°C)/Hum.(%RH):	26(°C)/60 %RH
Mode:	Mode 3		
Ant.Polar.:	Vertical		

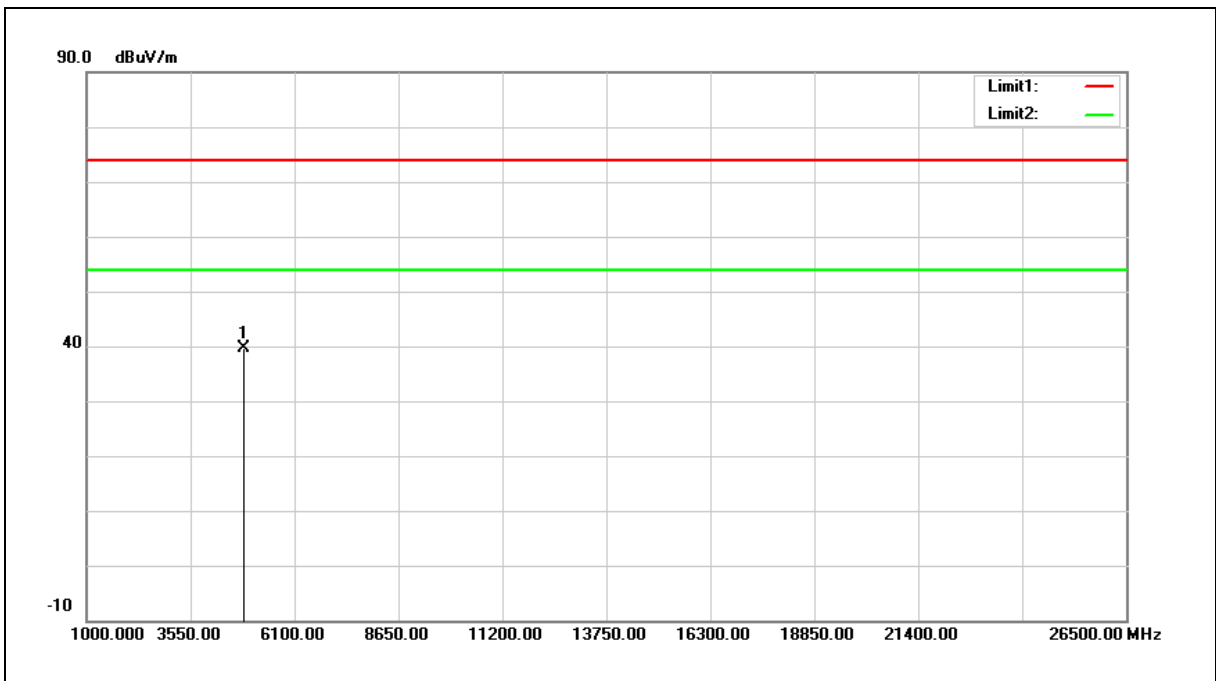

No.	Frequency (MHz)	Reading (dBuV)	Correct Factor (dB/m)	Result (dBuV/m)	Limit (dBuV/m)	Margin (dB)	Remark
1	4874.000	32.22	7.39	39.61	74.00	-34.39	peak

Note:1.Result (dBuV/m) = Correct Factor (dB/m) + Reading(dBuV).

2.Correction factor (dB/m) = Antenna Factor (dB/m) + Cable loss (dB) – Pre-Amplifier gain (dB).

3.When the peak results are less than average limit, so not need to evaluate the average.



Standard:	FCC Part 15.247	Test Distance:	3 m
Test item:	Harmonic	Power:	DC 3.3 V
Frequency:	2462 MHz	Temp.(°C)/Hum.(%RH):	26(°C)/60 %RH
Mode:	Mode 3		
Ant.Polar.:	Horizontal		

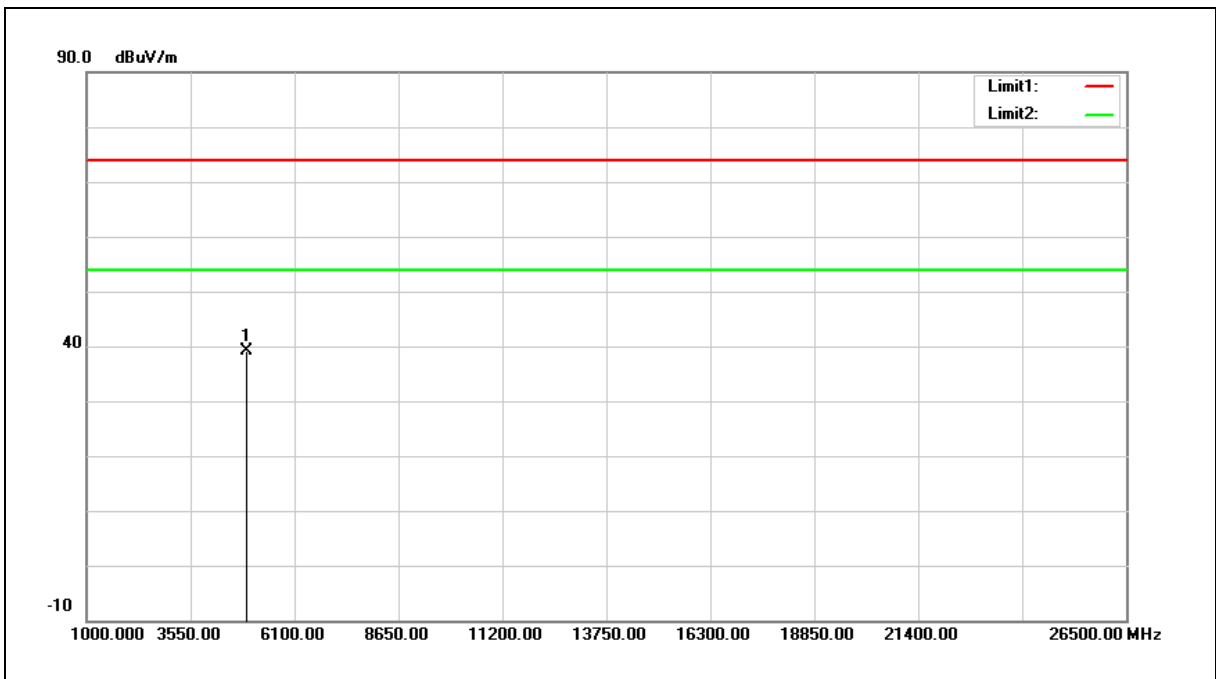

No.	Frequency (MHz)	Reading (dBuV)	Correct Factor (dB/m)	Result (dBuV/m)	Limit (dBuV/m)	Margin (dB)	Remark
1	4924.000	31.80	7.45	39.25	74.00	-34.75	peak

Note:1.Result (dBuV/m) = Correct Factor (dB/m) + Reading(dBuV).

2.Correction factor (dB/m) = Antenna Factor (dB/m) + Cable loss (dB) – Pre-Amplifier gain (dB).

3.When the peak results are less than average limit, so not need to evaluate the average.



Standard:	FCC Part 15.247	Test Distance:	3 m
Test item:	Harmonic	Power:	DC 3.3 V
Frequency:	2462 MHz	Temp.(°C)/Hum.(%RH):	26(°C)/60 %RH
Mode:	Mode 3		
Ant.Polar.:	Vertical		

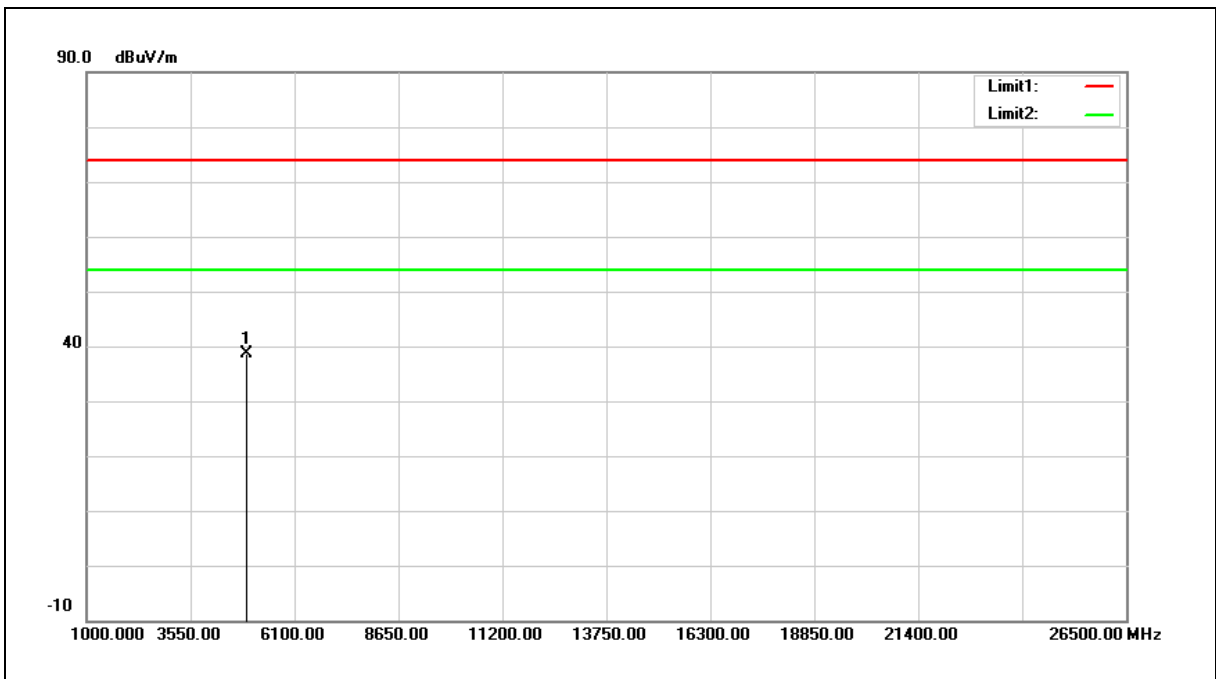

No.	Frequency (MHz)	Reading (dBuV)	Correct Factor (dB/m)	Result (dBuV/m)	Limit (dBuV/m)	Margin (dB)	Remark
1	4924.000	31.17	7.45	38.62	74.00	-35.38	peak

Note:1.Result (dBuV/m) = Correct Factor (dB/m) + Reading(dBuV).

2.Correction factor (dB/m) = Antenna Factor (dB/m) + Cable loss (dB) – Pre-Amplifier gain (dB).

3.When the peak results are less than average limit, so not need to evaluate the average.



Standard:	FCC Part 15.247	Test Distance:	3 m
Test item:	Harmonic	Power:	DC 3.3 V
Frequency:	2412 MHz	Temp.(°C)/Hum.(%RH):	26(°C)/60 %RH
Mode:	Mode 4		
Ant.Polar.:	Horizontal		

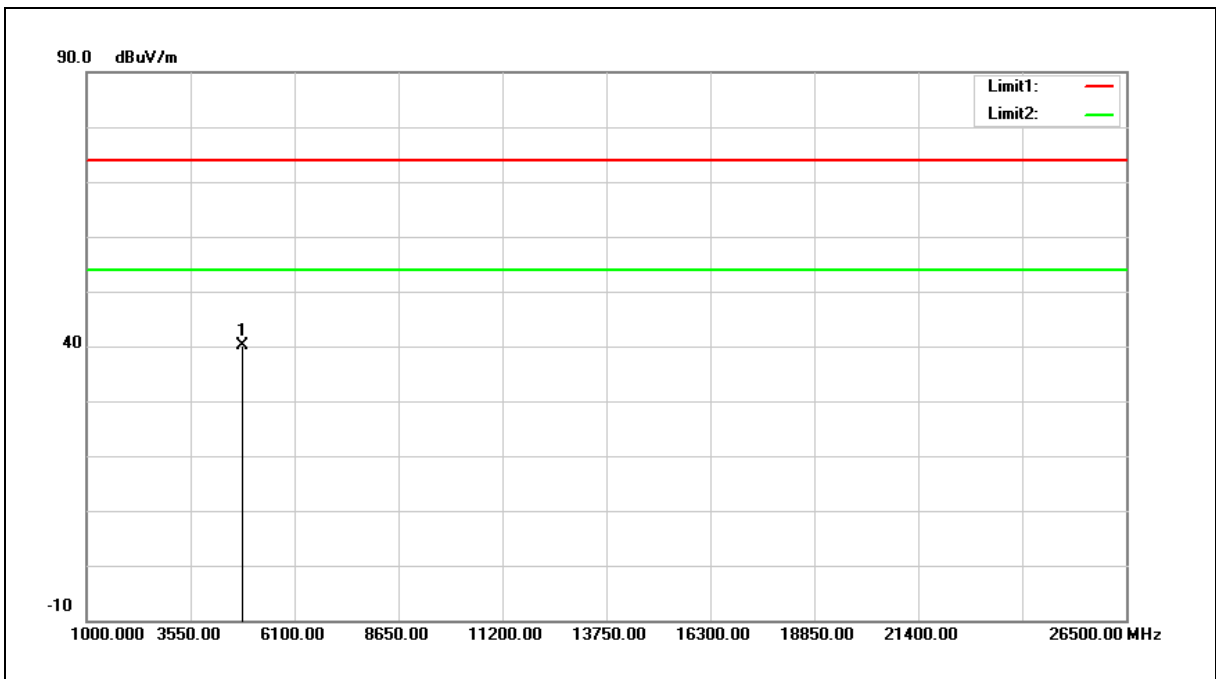

No.	Frequency (MHz)	Reading (dBuV)	Correct Factor (dB/m)	Result (dBuV/m)	Limit (dBuV/m)	Margin (dB)	Remark
1	4824.000	32.70	7.32	40.02	74.00	-33.98	peak

Note:1.Result (dBuV/m) = Correct Factor (dB/m) + Reading(dBuV).

2.Correction factor (dB/m) = Antenna Factor (dB/m) + Cable loss (dB) – Pre-Amplifier gain (dB).

3.When the peak results are less than average limit, so not need to evaluate the average.



Standard:	FCC Part 15.247	Test Distance:	3 m
Test item:	Harmonic	Power:	DC 3.3 V
Frequency:	2412 MHz	Temp.(°C)/Hum.(%RH):	26(°C)/60 %RH
Mode:	Mode 4		
Ant.Polar.:	Vertical		

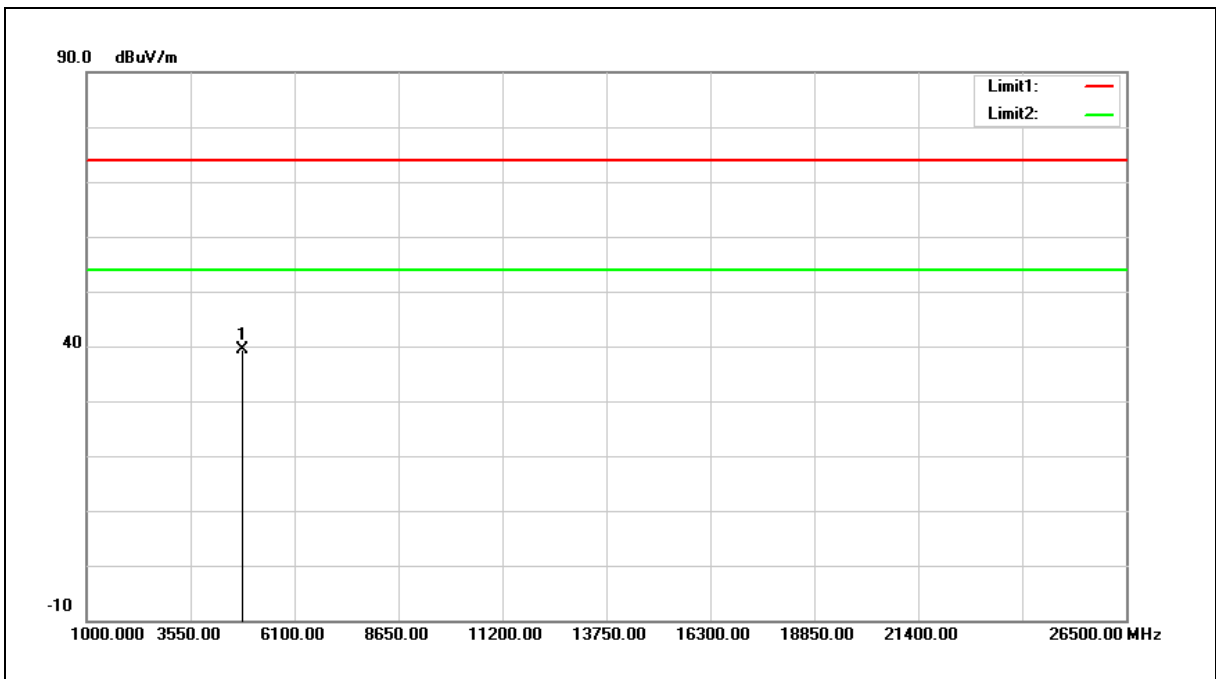

No.	Frequency (MHz)	Reading (dBuV)	Correct Factor (dB/m)	Result (dBuV/m)	Limit (dBuV/m)	Margin (dB)	Remark
1	4824.000	32.14	7.32	39.46	74.00	-34.54	peak

Note:1.Result (dBuV/m) = Correct Factor (dB/m) + Reading(dBuV).

2.Correction factor (dB/m) = Antenna Factor (dB/m) + Cable loss (dB) – Pre-Amplifier gain (dB).

3.When the peak results are less than average limit, so not need to evaluate the average.



Standard:	FCC Part 15.247	Test Distance:	3 m
Test item:	Harmonic	Power:	DC 3.3 V
Frequency:	2437 MHz	Temp.(°C)/Hum.(%RH):	26(°C)/60 %RH
Mode:	Mode 4		
Ant.Polar.:	Horizontal		

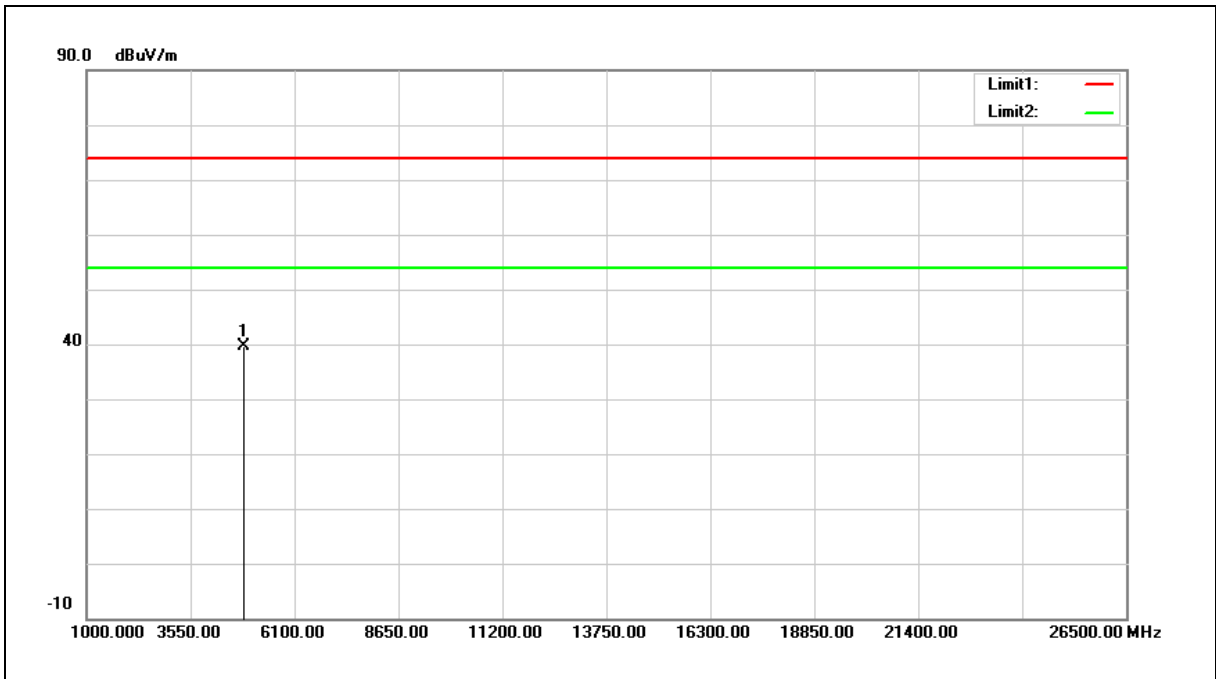

No.	Frequency (MHz)	Reading (dBuV)	Correct Factor (dB/m)	Result (dBuV/m)	Limit (dBuV/m)	Margin (dB)	Remark
1	4874.000	32.18	7.39	39.57	74.00	-34.43	peak

Note:1.Result (dBuV/m) = Correct Factor (dB/m) + Reading(dBuV).

2.Correction factor (dB/m) = Antenna Factor (dB/m) + Cable loss (dB) – Pre-Amplifier gain (dB).

3.When the peak results are less than average limit, so not need to evaluate the average.



Standard:	FCC Part 15.247	Test Distance:	3 m
Test item:	Harmonic	Power:	DC 3.3 V
Frequency:	2437 MHz	Temp.(°C)/Hum.(%RH):	26(°C)/60 %RH
Mode:	Mode 4		
Ant.Polar.:	Vertical		

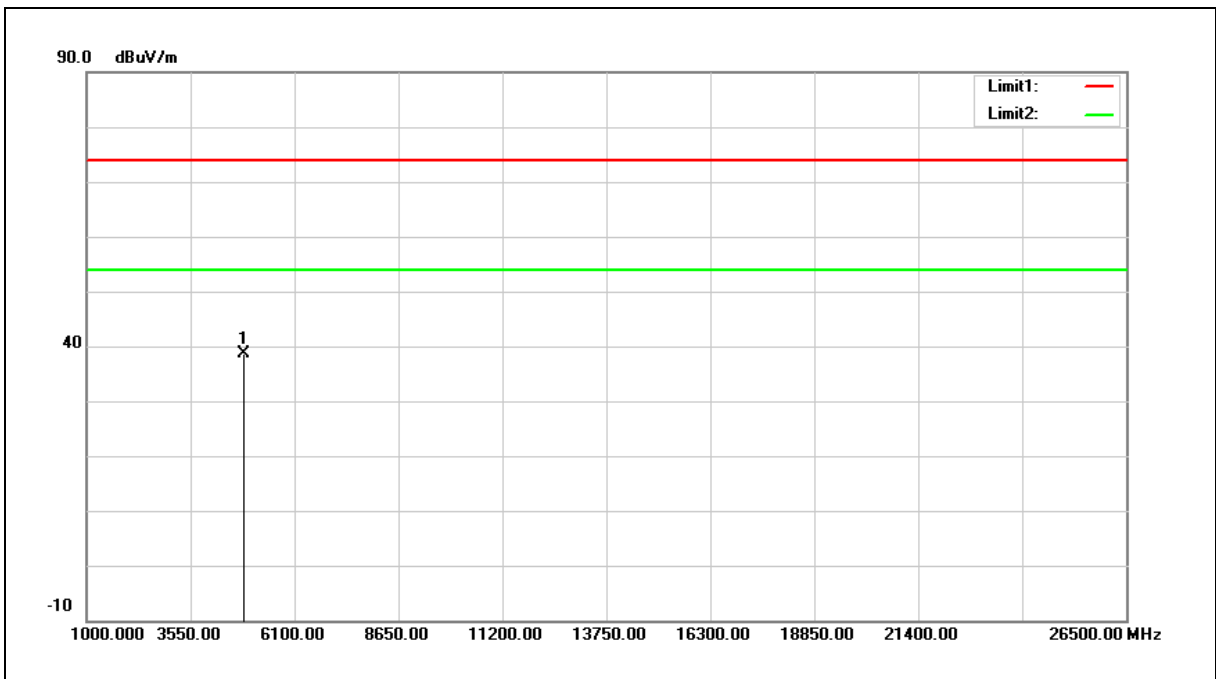

No.	Frequency (MHz)	Reading (dBuV)	Correct Factor (dB/m)	Result (dBuV/m)	Limit (dBuV/m)	Margin (dB)	Remark
1	4874.000	31.18	7.39	38.57	74.00	-35.43	peak

Note:1.Result (dBuV/m) = Correct Factor (dB/m) + Reading(dBuV).

2.Correction factor (dB/m) = Antenna Factor (dB/m) + Cable loss (dB) – Pre-Amplifier gain (dB).

3.When the peak results are less than average limit, so not need to evaluate the average.



Standard:	FCC Part 15.247	Test Distance:	3 m
Test item:	Harmonic	Power:	DC 3.3 V
Frequency:	2462 MHz	Temp.(°C)/Hum.(%RH):	26(°C)/60 %RH
Mode:	Mode 4		
Ant.Polar.:	Horizontal		

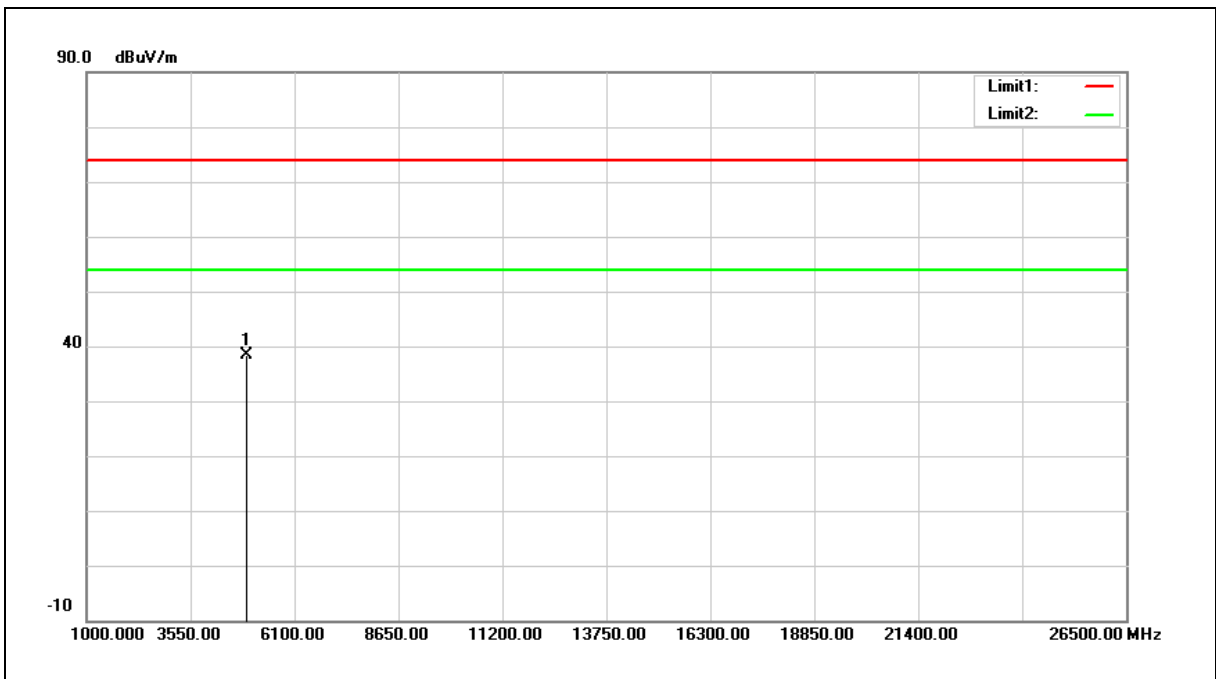

No.	Frequency (MHz)	Reading (dBuV)	Correct Factor (dB/m)	Result (dBuV/m)	Limit (dBuV/m)	Margin (dB)	Remark
1	4924.000	31.05	7.45	38.50	74.00	-35.50	peak

Note:1.Result (dBuV/m) = Correct Factor (dB/m) + Reading(dBuV).

2.Correction factor (dB/m) = Antenna Factor (dB/m) + Cable loss (dB) – Pre-Amplifier gain (dB).

3.When the peak results are less than average limit, so not need to evaluate the average.



Standard:	FCC Part 15.247	Test Distance:	3 m
Test item:	Harmonic	Power:	DC 3.3 V
Frequency:	2462 MHz	Temp.(°C)/Hum.(%RH):	26(°C)/60 %RH
Mode:	Mode 4		
Ant.Polar.:	Vertical		

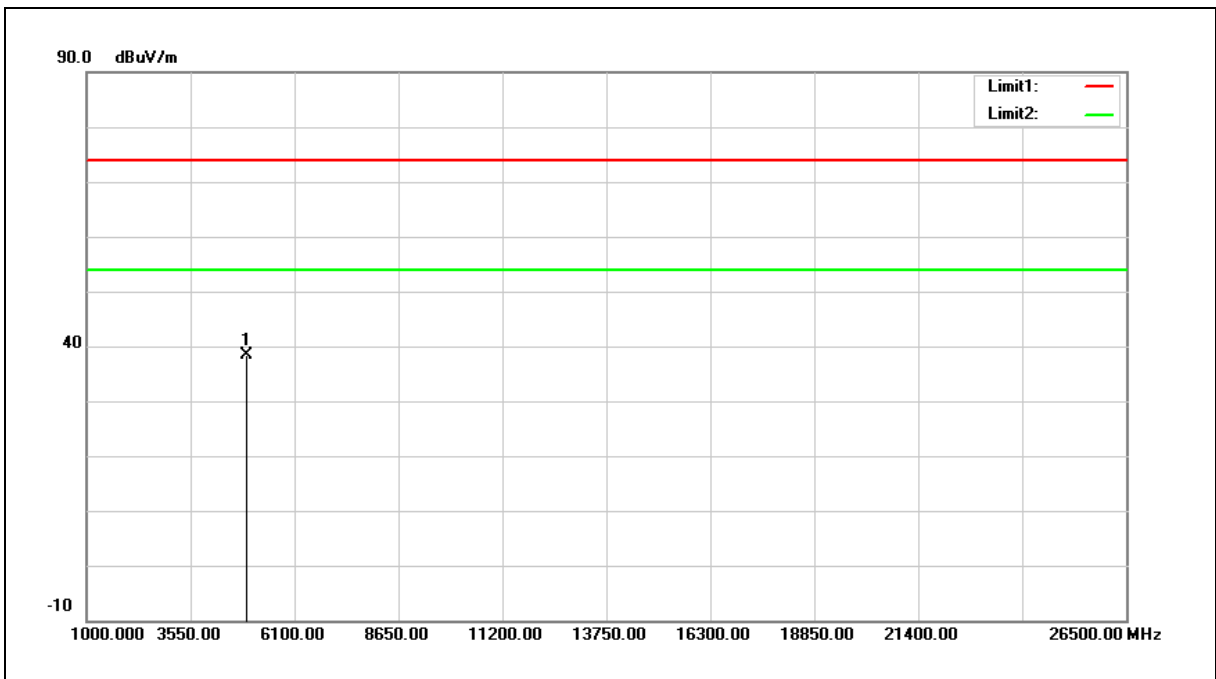

No.	Frequency (MHz)	Reading (dBuV)	Correct Factor (dB/m)	Result (dBuV/m)	Limit (dBuV/m)	Margin (dB)	Remark
1	4924.000	30.98	7.45	38.43	74.00	-35.57	peak

Note:1.Result (dBuV/m) = Correct Factor (dB/m) + Reading(dBuV).

2.Correction factor (dB/m) = Antenna Factor (dB/m) + Cable loss (dB) – Pre-Amplifier gain (dB).

3.When the peak results are less than average limit, so not need to evaluate the average.



Standard:	FCC Part 15.247	Test Distance:	3 m
Test item:	Harmonic	Power:	DC 3.3 V
Frequency:	2422 MHz	Temp.(°C)/Hum.(%RH):	26(°C)/60 %RH
Mode:	Mode 5		
Ant.Polar.:	Horizontal		

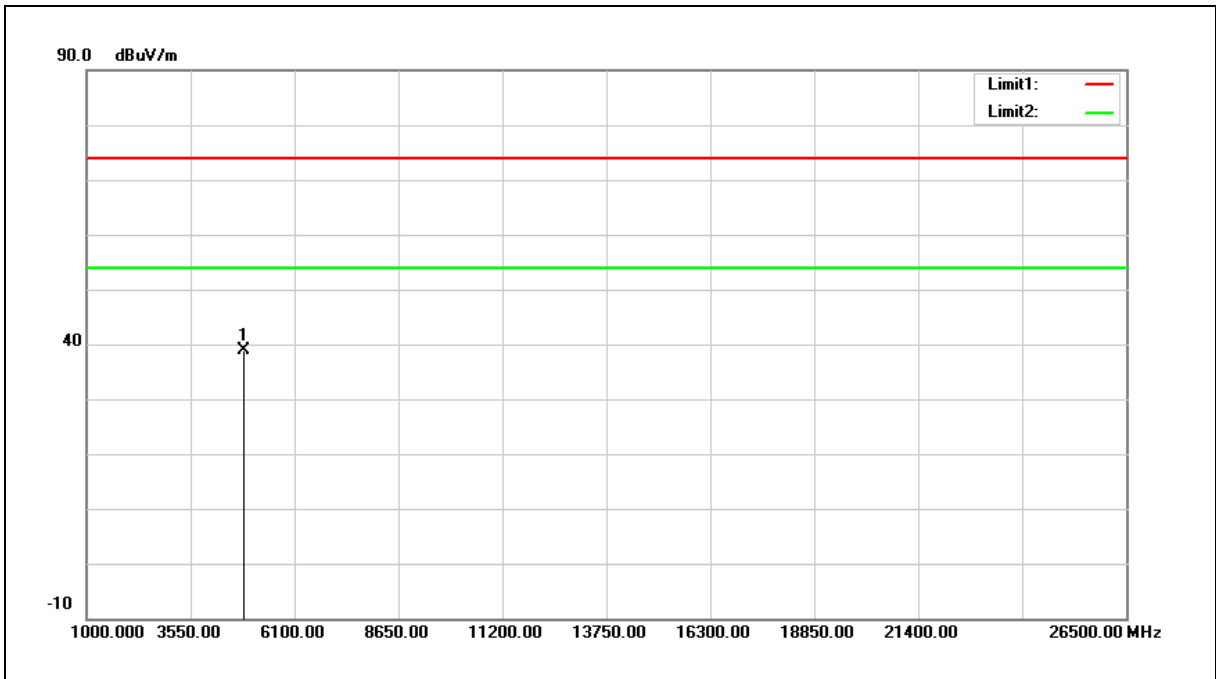

No.	Frequency (MHz)	Reading (dBuV)	Correct Factor (dB/m)	Result (dBuV/m)	Limit (dBuV/m)	Margin (dB)	Remark
1	4844.000	31.43	7.36	38.79	74.00	-35.21	peak

Note:1.Result (dBuV/m) = Correct Factor (dB/m) + Reading(dBuV).

2.Correction factor (dB/m) = Antenna Factor (dB/m) + Cable loss (dB) – Pre-Amplifier gain (dB).

3.When the peak results are less than average limit, so not need to evaluate the average.



Standard:	FCC Part 15.247	Test Distance:	3 m
Test item:	Harmonic	Power:	DC 3.3 V
Frequency:	2422 MHz	Temp.(°C)/Hum.(%RH):	26(°C)/60 %RH
Mode:	Mode 5		
Ant.Polar.:	Vertical		

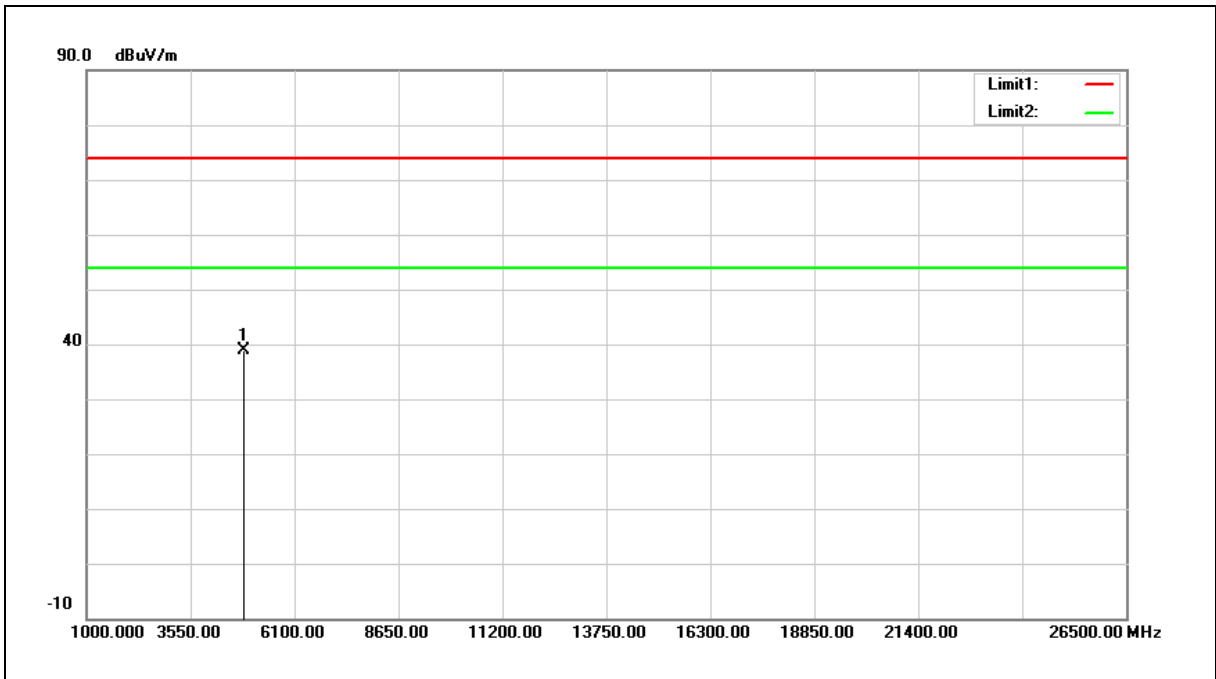

No.	Frequency (MHz)	Reading (dBuV)	Correct Factor (dB/m)	Result (dBuV/m)	Limit (dBuV/m)	Margin (dB)	Remark
1	4844.000	31.50	7.36	38.86	74.00	-35.14	peak

Note:1.Result (dBuV/m) = Correct Factor (dB/m) + Reading(dBuV).

2.Correction factor (dB/m) = Antenna Factor (dB/m) + Cable loss (dB) – Pre-Amplifier gain (dB).

3.When the peak results are less than average limit, so not need to evaluate the average.



Standard:	FCC Part 15.247	Test Distance:	3 m
Test item:	Harmonic	Power:	DC 3.3 V
Frequency:	2437 MHz	Temp.(°C)/Hum.(%RH):	26(°C)/60 %RH
Mode:	Mode 5		
Ant.Polar.:	Horizontal		

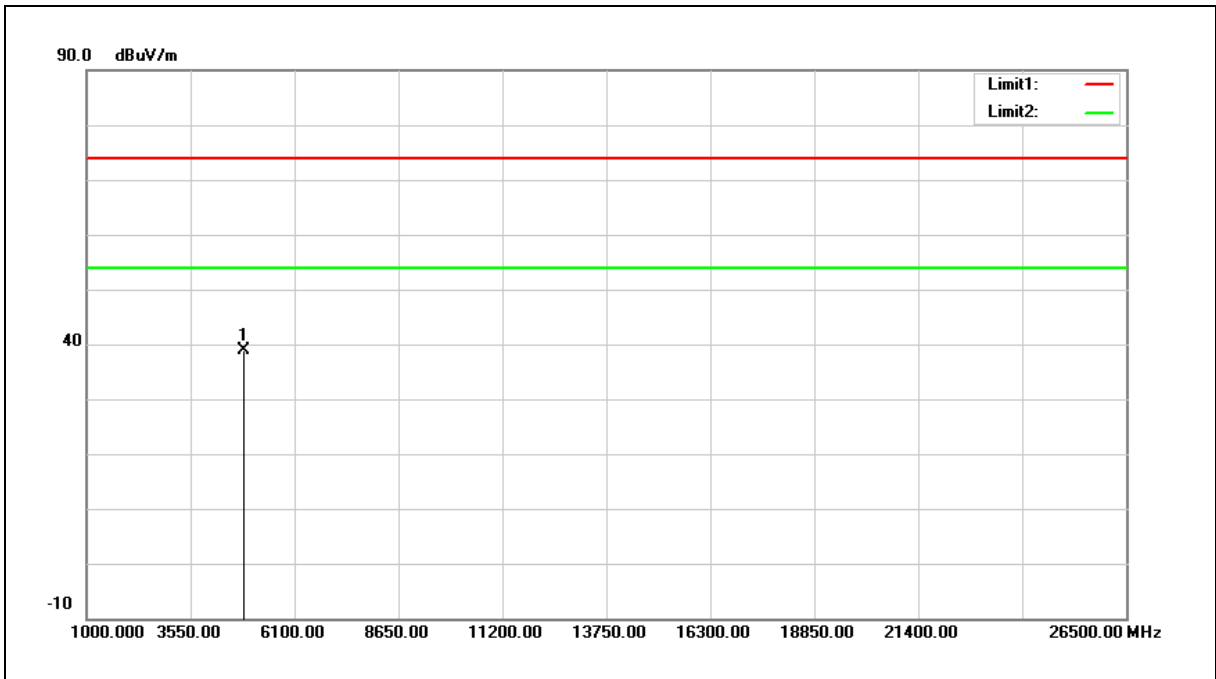

No.	Frequency (MHz)	Reading (dBuV)	Correct Factor (dB/m)	Result (dBuV/m)	Limit (dBuV/m)	Margin (dB)	Remark
1	4874.000	31.46	7.39	38.85	74.00	-35.15	peak

Note:1.Result (dBuV/m) = Correct Factor (dB/m) + Reading(dBuV).

2.Correction factor (dB/m) = Antenna Factor (dB/m) + Cable loss (dB) – Pre-Amplifier gain (dB).

3.When the peak results are less than average limit, so not need to evaluate the average.



Standard:	FCC Part 15.247	Test Distance:	3 m
Test item:	Harmonic	Power:	DC 3.3 V
Frequency:	2437 MHz	Temp.(°C)/Hum.(%RH):	26(°C)/60 %RH
Mode:	Mode 5		
Ant.Polar.:	Vertical		

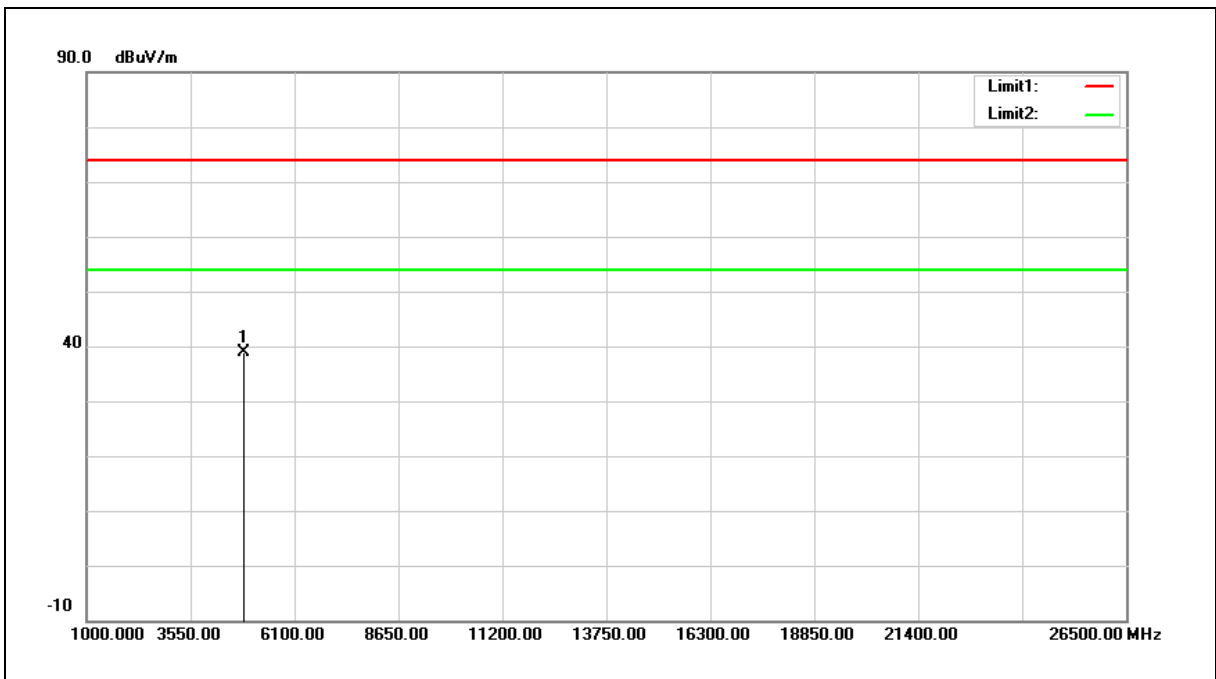

No.	Frequency (MHz)	Reading (dBuV)	Correct Factor (dB/m)	Result (dBuV/m)	Limit (dBuV/m)	Margin (dB)	Remark
1	4874.000	31.38	7.39	38.77	74.00	-35.23	peak

Note:1.Result (dBuV/m) = Correct Factor (dB/m) + Reading(dBuV).

2.Correction factor (dB/m) = Antenna Factor (dB/m) + Cable loss (dB) – Pre-Amplifier gain (dB).

3.When the peak results are less than average limit, so not need to evaluate the average.



Standard:	FCC Part 15.247	Test Distance:	3 m
Test item:	Harmonic	Power:	DC 3.3 V
Frequency:	2452 MHz	Temp.(°C)/Hum.(%RH):	26(°C)/60 %RH
Mode:	Mode 5		
Ant.Polar.:	Horizontal		

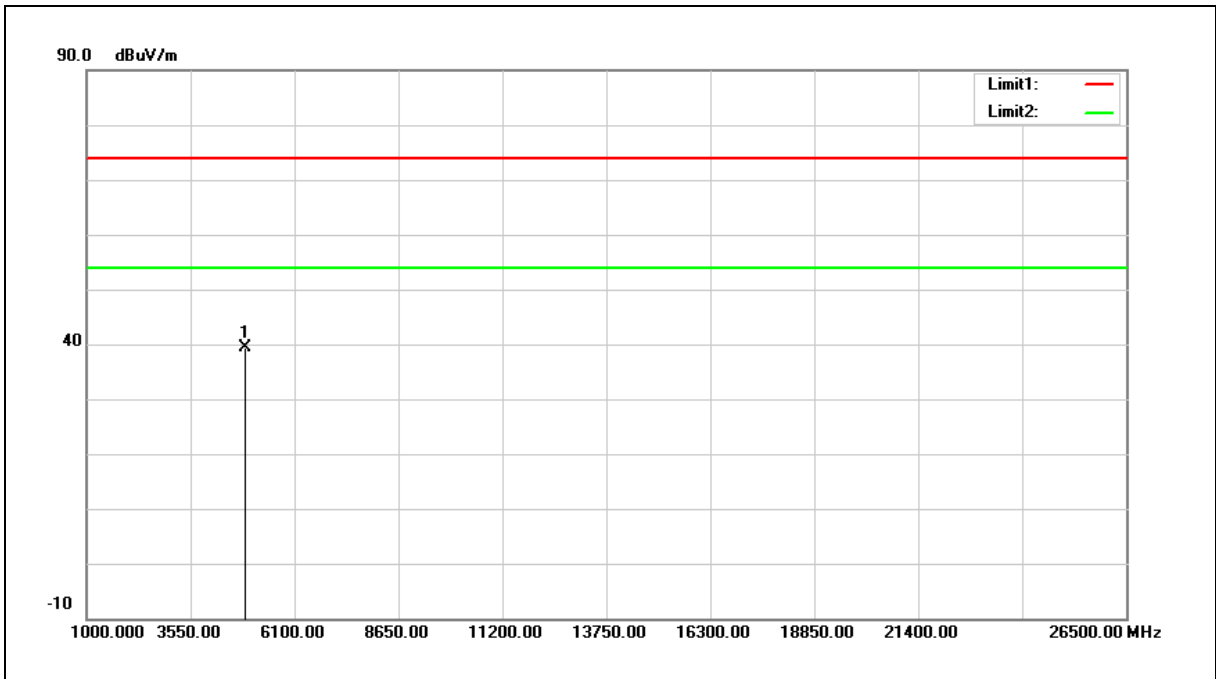

No.	Frequency (MHz)	Reading (dBuV)	Correct Factor (dB/m)	Result (dBuV/m)	Limit (dBuV/m)	Margin (dB)	Remark
1	4904.000	32.06	7.43	39.49	74.00	-34.51	peak

Note:1.Result (dBuV/m) = Correct Factor (dB/m) + Reading(dBuV).

2.Correction factor (dB/m) = Antenna Factor (dB/m) + Cable loss (dB) – Pre-Amplifier gain (dB).

3.When the peak results are less than average limit, so not need to evaluate the average.



Standard:	FCC Part 15.247	Test Distance:	3 m
Test item:	Harmonic	Power:	DC 3.3 V
Frequency:	2452 MHz	Temp.(°C)/Hum.(%RH):	26(°C)/60 %RH
Mode:	Mode 5		
Ant.Polar.:	Vertical		

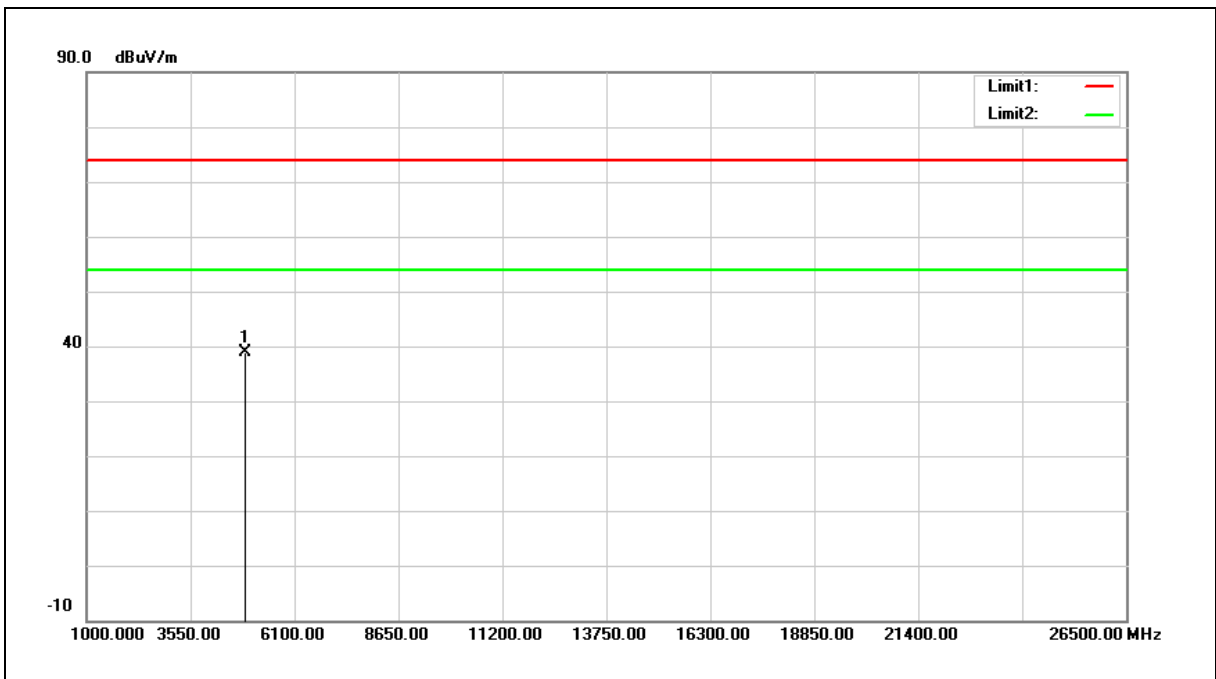

No.	Frequency (MHz)	Reading (dBuV)	Correct Factor (dB/m)	Result (dBuV/m)	Limit (dBuV/m)	Margin (dB)	Remark
1	4904.000	31.38	7.43	38.81	74.00	-35.19	peak

Note:1.Result (dBuV/m) = Correct Factor (dB/m) + Reading(dBuV).

2.Correction factor (dB/m) = Antenna Factor (dB/m) + Cable loss (dB) – Pre-Amplifier gain (dB).

3.When the peak results are less than average limit, so not need to evaluate the average.



Power setting 2_Antenna Type: Heavy Duty Screw Mount Antenna

Below 1 GHz

Standard:	FCC Part 15.247	Test Distance:	3 m
Test item:	Harmonic	Power:	DC 3.3 V
Test Mode:	Mode 1	Temp.(°C)/Hum.(%RH):	26(°C)/60 %RH

Frequency (MHz)	Reading (dBuV)	Correct Factor (dB/m)	Result (dBuV/m)	Limit (dBuV/m)	Margin (dB)	Remark	Ant.Polar. H / V
77.5300	44.14	-14.41	29.73	40.00	-10.27	QP	H
149.3100	40.59	-9.93	30.66	43.50	-12.84	QP	H
225.9400	44.36	-12.93	31.43	46.00	-14.57	QP	H
304.5100	42.55	-10.14	32.41	46.00	-13.59	QP	H
507.2400	38.02	-5.13	32.89	46.00	-13.11	QP	H
767.2000	37.21	0.08	37.29	46.00	-8.71	QP	H
71.7100	44.92	-13.62	31.30	40.00	-8.70	QP	V
160.9500	39.08	-10.80	28.28	43.50	-15.22	QP	V
225.9400	44.33	-12.93	31.40	46.00	-14.60	QP	V
458.7400	37.06	-5.96	31.10	46.00	-14.90	QP	V
660.5000	35.74	-2.02	33.72	46.00	-12.28	QP	V
857.4100	36.47	0.94	37.41	46.00	-8.59	QP	V

Note:1.Result (dBuV/m) = Correct Factor (dB/m) + Reading(dBuV).

2.Correction factor (dB/m) = Antenna Factor (dB/m) + Cable loss (dB) – Pre-Amplifier gain (dB).

3.When the peak results are less than average limit, so not need to evaluate the average.



Above 1 GHz

Standard:	FCC Part 15.247	Test Distance:	3 m
Test item:	Harmonic	Power:	DC 3.3 V
Frequency:	2412 MHz	Temp.(°C)/Hum.(%RH):	26(°C)/60 %RH
Mode:	Mode 2		
Ant.Polar.:	Horizontal		

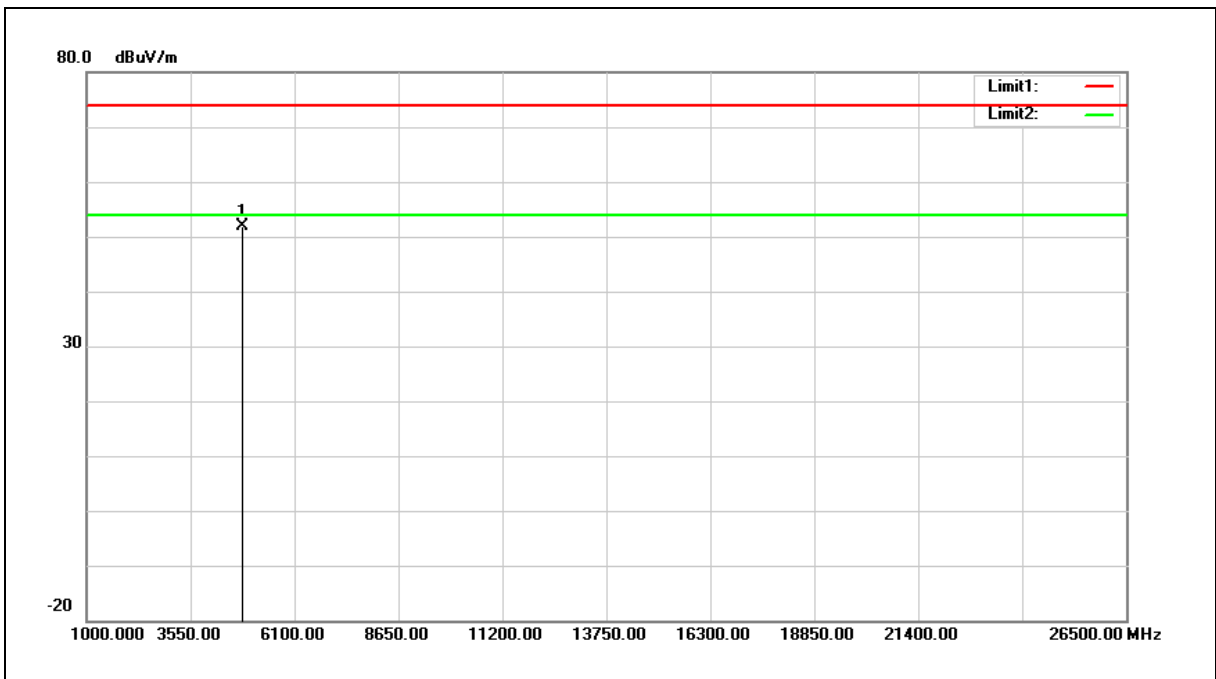

No.	Frequency (MHz)	Reading (dBuV)	Correct Factor (dB/m)	Result (dBuV/m)	Limit (dBuV/m)	Margin (dB)	Remark
1	4824.000	56.63	-4.82	51.81	74.00	-22.19	peak

Note:1.Result (dBuV/m) = Correct Factor (dB/m) + Reading(dBuV).

2.Correction factor (dB/m) = Antenna Factor (dB/m) + Cable loss (dB) – Pre-Amplifier gain (dB).

3.When the peak results are less than average limit, so not need to evaluate the average.



Standard:	FCC Part 15.247	Test Distance:	3 m
Test item:	Harmonic	Power:	DC 3.3 V
Frequency:	2412 MHz	Temp.(°C)/Hum.(%RH):	26(°C)/60 %RH
Mode:	Mode 2		
Ant.Polar.:	Vertical		

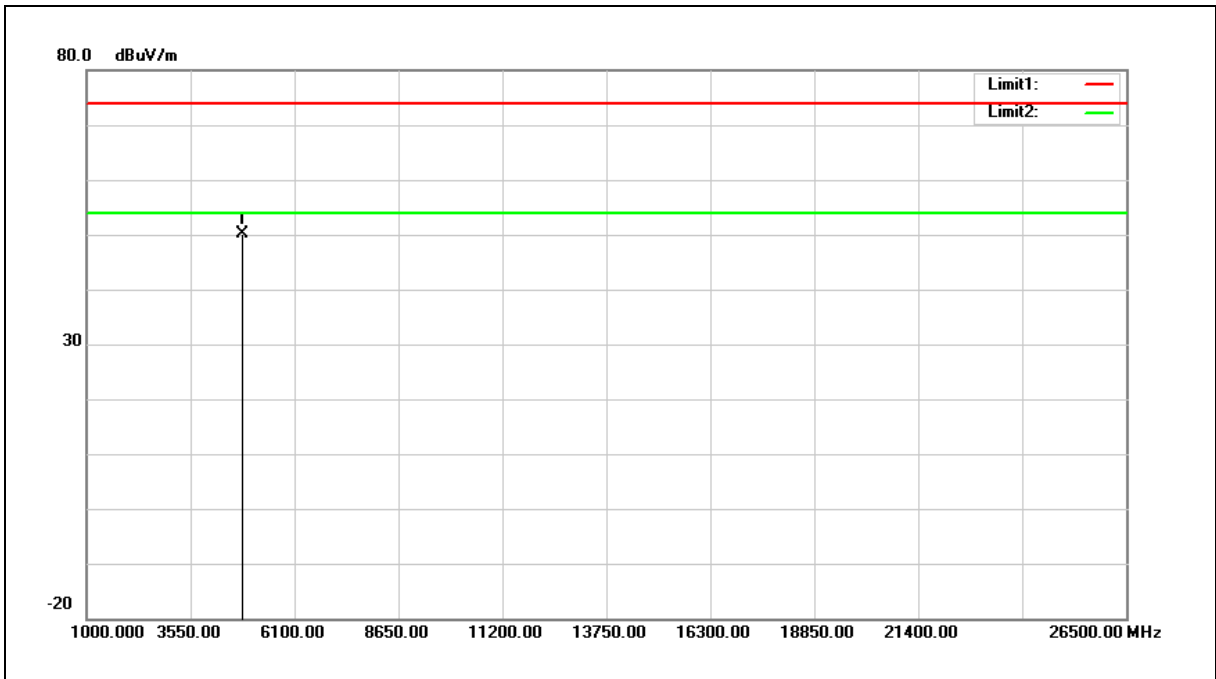

No.	Frequency (MHz)	Reading (dBuV)	Correct Factor (dB/m)	Result (dBuV/m)	Limit (dBuV/m)	Margin (dB)	Remark
1	4824.000	55.05	-4.82	50.23	74.00	-23.77	peak

Note:1.Result (dBuV/m) = Correct Factor (dB/m) + Reading(dBuV).

2.Correction factor (dB/m) = Antenna Factor (dB/m) + Cable loss (dB) – Pre-Amplifier gain (dB).

3.When the peak results are less than average limit, so not need to evaluate the average.



Standard:	FCC Part 15.247	Test Distance:	3 m
Test item:	Harmonic	Power:	DC 3.3 V
Frequency:	2437 MHz	Temp.(°C)/Hum.(%RH):	26(°C)/60 %RH
Mode:	Mode 2		
Ant.Polar.:	Horizontal		

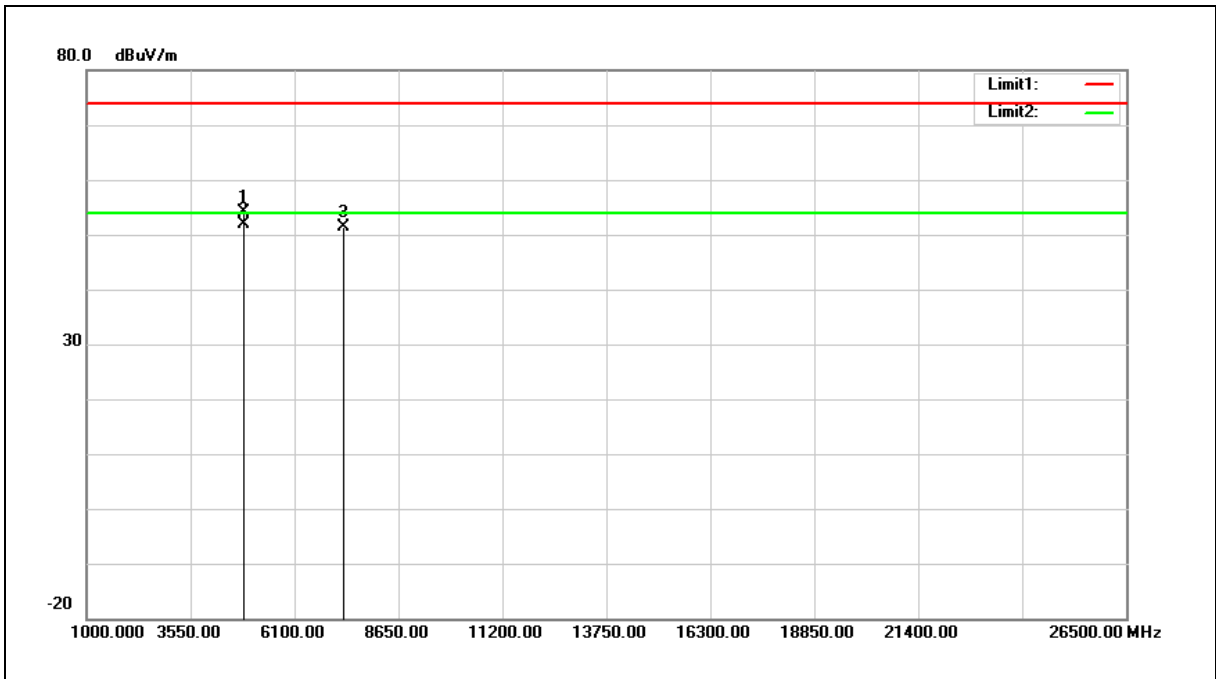

No.	Frequency (MHz)	Reading (dBuV)	Correct Factor (dB/m)	Result (dBuV/m)	Limit (dBuV/m)	Margin (dB)	Remark
1	4874.000	59.02	-4.84	54.18	74.00	-19.82	peak
2	4874.000	56.81	-4.84	51.97	54.00	-2.03	AVG
3	7311.000	51.70	-0.23	51.47	74.00	-22.53	peak

Note:1.Result (dBuV/m) = Correct Factor (dB/m) + Reading(dBuV).

2.Correction factor (dB/m) = Antenna Factor (dB/m) + Cable loss (dB) – Pre-Amplifier gain (dB).

3.When the peak results are less than average limit, so not need to evaluate the average.



Standard:	FCC Part 15.247	Test Distance:	3 m
Test item:	Harmonic	Power:	DC 3.3 V
Frequency:	2437 MHz	Temp.(°C)/Hum.(%RH):	26(°C)/60 %RH
Mode:	Mode 2		
Ant.Polar.:	Vertical		

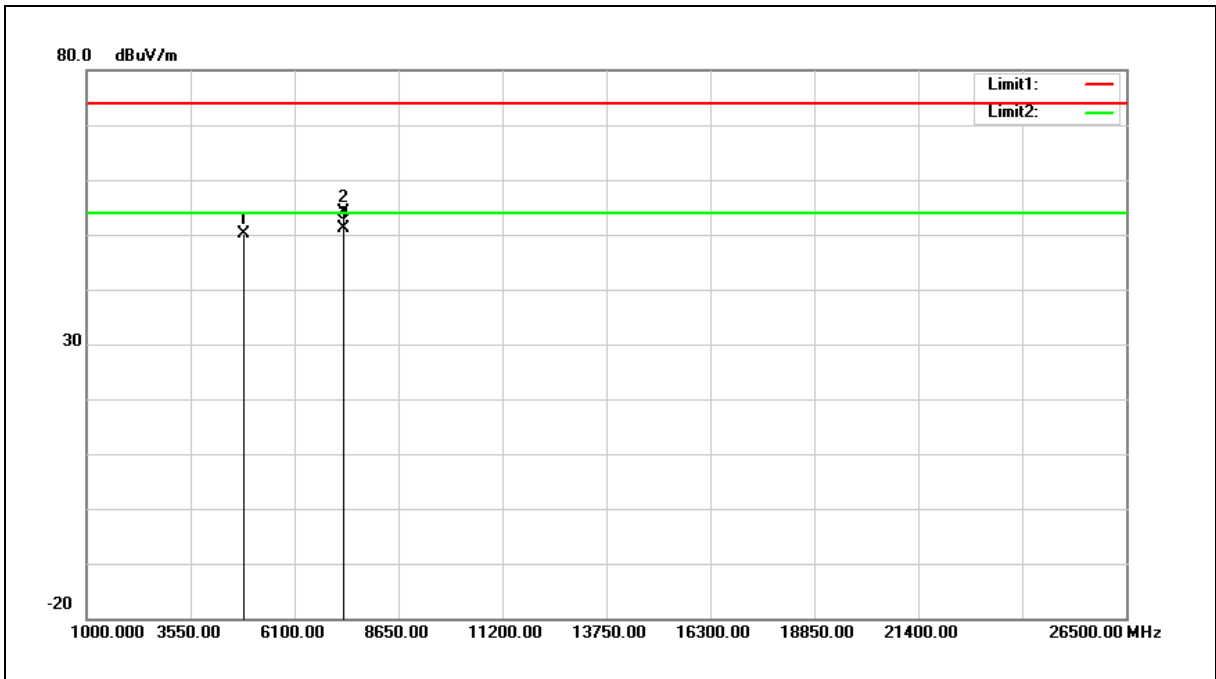

No.	Frequency (MHz)	Reading (dBuV)	Correct Factor (dB/m)	Result (dBuV/m)	Limit (dBuV/m)	Margin (dB)	Remark
1	4874.000	55.06	-4.84	50.22	74.00	-23.78	peak
2	7311.000	54.47	-0.23	54.24	74.00	-19.76	peak
3	7311.000	51.31	-0.23	51.08	54.00	-2.92	AVG

Note:1.Result (dBuV/m) = Correct Factor (dB/m) + Reading(dBuV).

2.Correction factor (dB/m) = Antenna Factor (dB/m) + Cable loss (dB) – Pre-Amplifier gain (dB).

3.When the peak results are less than average limit, so not need to evaluate the average.



Standard:	FCC Part 15.247	Test Distance:	3 m
Test item:	Harmonic	Power:	DC 3.3 V
Frequency:	2462 MHz	Temp.(°C)/Hum.(%RH):	26(°C)/60 %RH
Mode:	Mode 2		
Ant.Polar.:	Horizontal		

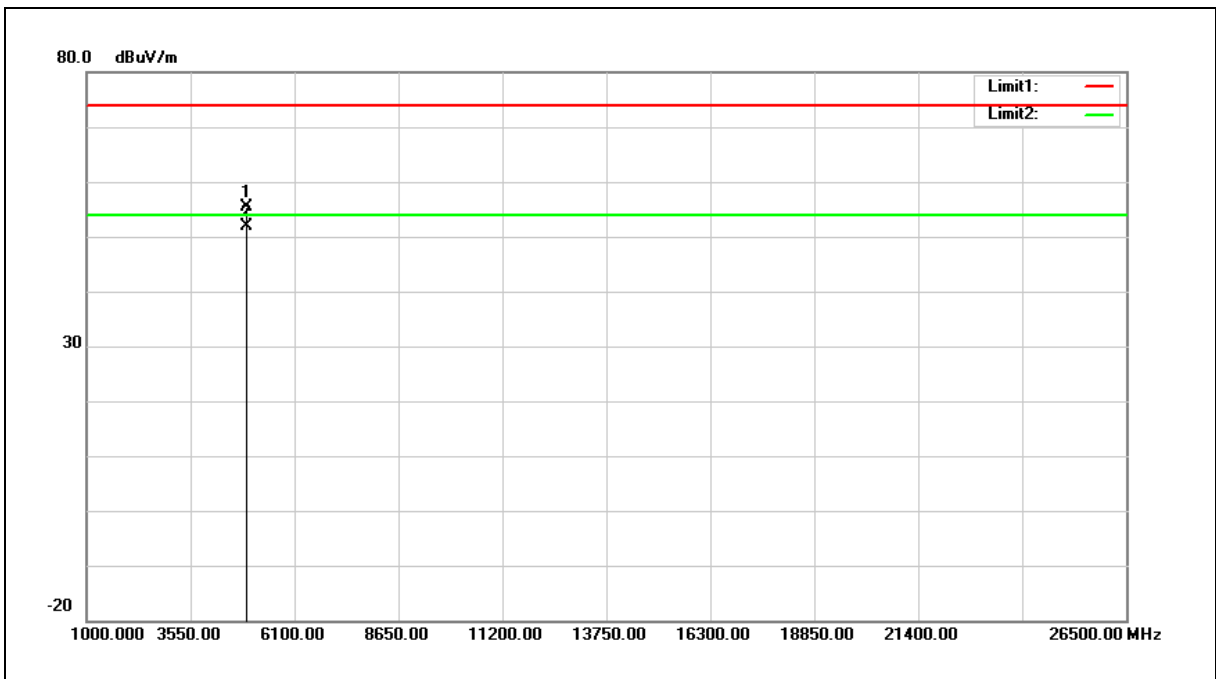

No.	Frequency (MHz)	Reading (dBuV)	Correct Factor (dB/m)	Result (dBuV/m)	Limit (dBuV/m)	Margin (dB)	Remark
1	4924.000	60.37	-4.87	55.50	74.00	-18.50	peak
2	4924.000	56.83	-4.87	51.96	54.00	-2.04	AVG

Note:1.Result (dBuV/m) = Correct Factor (dB/m) + Reading(dBuV).

2.Correction factor (dB/m) = Antenna Factor (dB/m) + Cable loss (dB) – Pre-Amplifier gain (dB).

3.When the peak results are less than average limit, so not need to evaluate the average.



Standard:	FCC Part 15.247	Test Distance:	3 m
Test item:	Harmonic	Power:	DC 3.3 V
Frequency:	2462 MHz	Temp.(°C)/Hum.(%RH):	26(°C)/60 %RH
Mode:	Mode 2		
Ant.Polar.:	Vertical		

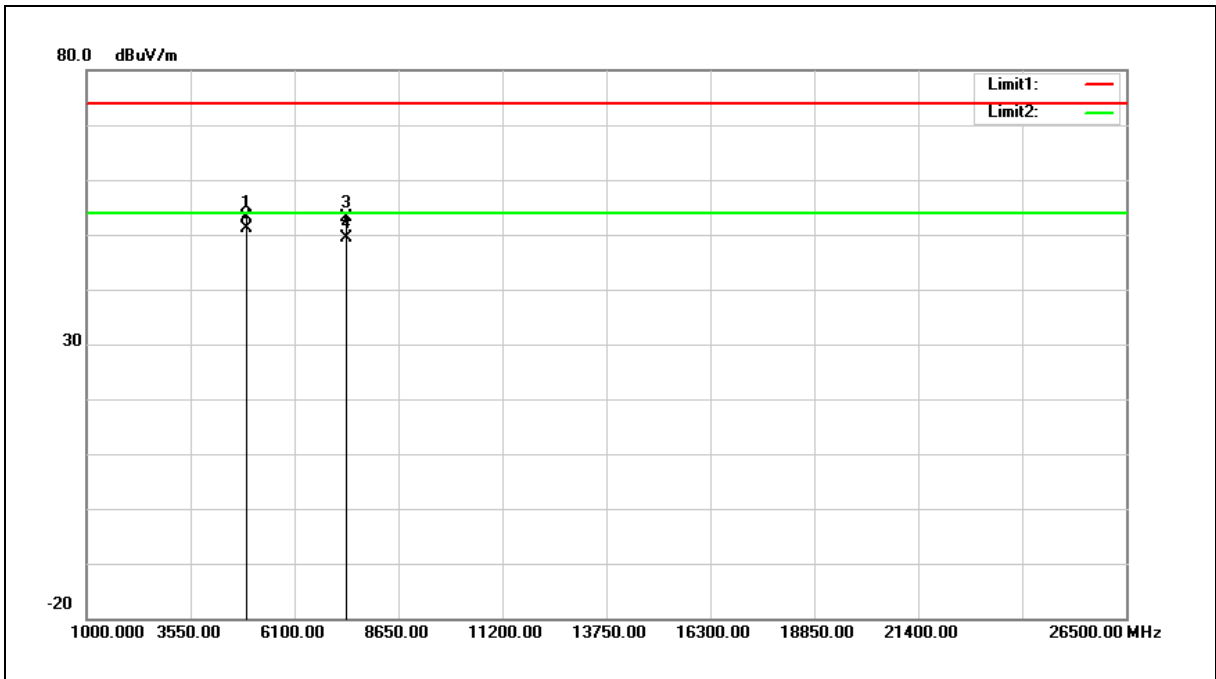

No.	Frequency (MHz)	Reading (dBuV)	Correct Factor (dB/m)	Result (dBuV/m)	Limit (dBuV/m)	Margin (dB)	Remark
1	4924.000	58.08	-4.87	53.21	74.00	-20.79	peak
2	4924.000	55.94	-4.87	51.07	54.00	-2.93	AVG
3	7386.000	53.10	-0.02	53.08	74.00	-20.92	peak
4	7386.000	49.36	-0.02	49.34	54.00	-4.66	AVG

- Note:1.Result (dBuV/m) = Correct Factor (dB/m) + Reading(dBuV).
 2.Correction factor (dB/m) = Antenna Factor (dB/m) + Cable loss (dB) – Pre-Amplifier gain (dB).
 3.When the peak results are less than average limit, so not need to evaluate the average.



Standard:	FCC Part 15.247	Test Distance:	3 m
Test item:	Harmonic	Power:	DC 3.3 V
Frequency:	2412 MHz	Temp.(°C)/Hum.(%RH):	26(°C)/60 %RH
Mode:	Mode 3		
Ant.Polar.:	Horizontal		

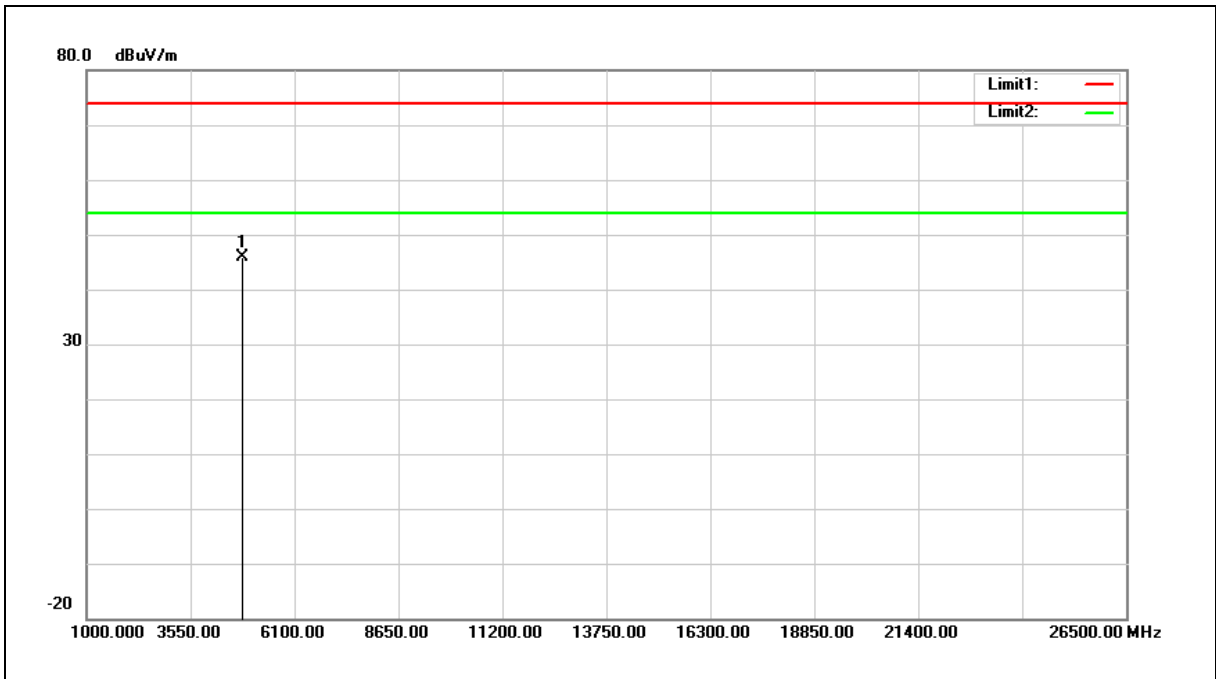

No.	Frequency (MHz)	Reading (dBuV)	Correct Factor (dB/m)	Result (dBuV/m)	Limit (dBuV/m)	Margin (dB)	Remark
1	4824.000	50.59	-4.82	45.77	74.00	-28.23	peak

Note:1.Result (dBuV/m) = Correct Factor (dB/m) + Reading(dBuV).

2.Correction factor (dB/m) = Antenna Factor (dB/m) + Cable loss (dB) – Pre-Amplifier gain (dB).

3.When the peak results are less than average limit, so not need to evaluate the average.



Standard:	FCC Part 15.247	Test Distance:	3 m
Test item:	Harmonic	Power:	DC 3.3 V
Frequency:	2412 MHz	Temp.(°C)/Hum.(%RH):	26(°C)/60 %RH
Mode:	Mode 3		
Ant.Polar.:	Vertical		

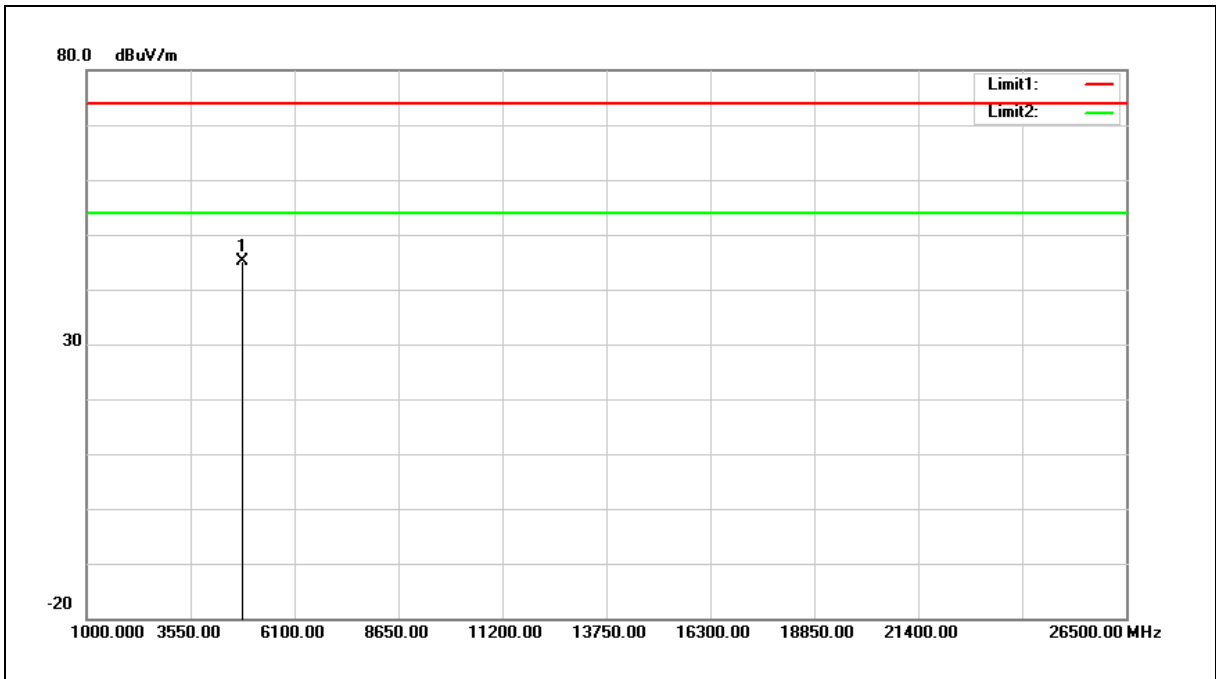

No.	Frequency (MHz)	Reading (dBuV)	Correct Factor (dB/m)	Result (dBuV/m)	Limit (dBuV/m)	Margin (dB)	Remark
1	4824.000	49.95	-4.82	45.13	74.00	-28.87	peak

Note:1.Result (dBuV/m) = Correct Factor (dB/m) + Reading(dBuV).

2.Correction factor (dB/m) = Antenna Factor (dB/m) + Cable loss (dB) – Pre-Amplifier gain (dB).

3.When the peak results are less than average limit, so not need to evaluate the average.



Standard:	FCC Part 15.247	Test Distance:	3 m
Test item:	Harmonic	Power:	DC 3.3 V
Frequency:	2437 MHz	Temp.(°C)/Hum.(%RH):	26(°C)/60 %RH
Mode:	Mode 3		
Ant.Polar.:	Horizontal		

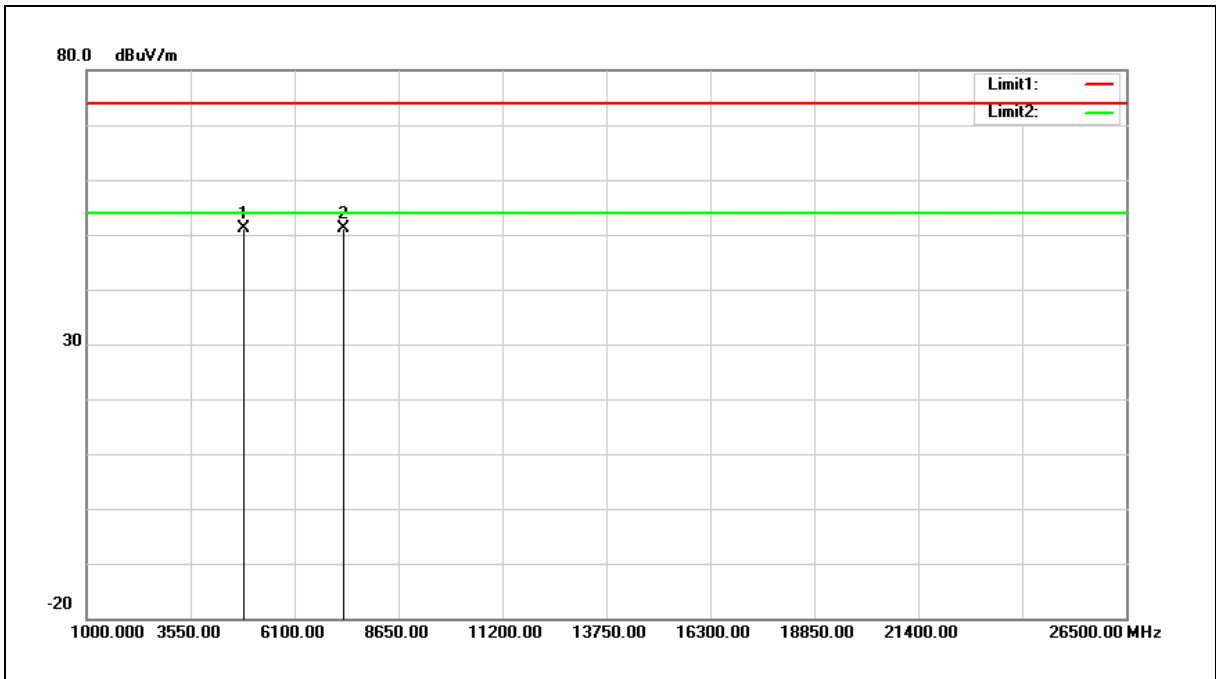

No.	Frequency (MHz)	Reading (dBuV)	Correct Factor (dB/m)	Result (dBuV/m)	Limit (dBuV/m)	Margin (dB)	Remark
1	4874.000	56.07	-4.84	51.23	74.00	-22.77	peak
2	7311.000	51.34	-0.23	51.11	74.00	-22.89	peak

Note:1.Result (dBuV/m) = Correct Factor (dB/m) + Reading(dBuV).

2.Correction factor (dB/m) = Antenna Factor (dB/m) + Cable loss (dB) – Pre-Amplifier gain (dB).

3.When the peak results are less than average limit, so not need to evaluate the average.



Standard:	FCC Part 15.247	Test Distance:	3 m
Test item:	Harmonic	Power:	DC 3.3 V
Frequency:	2437 MHz	Temp.(°C)/Hum.(%RH):	26(°C)/60 %RH
Mode:	Mode 3		
Ant.Polar.:	Vertical		

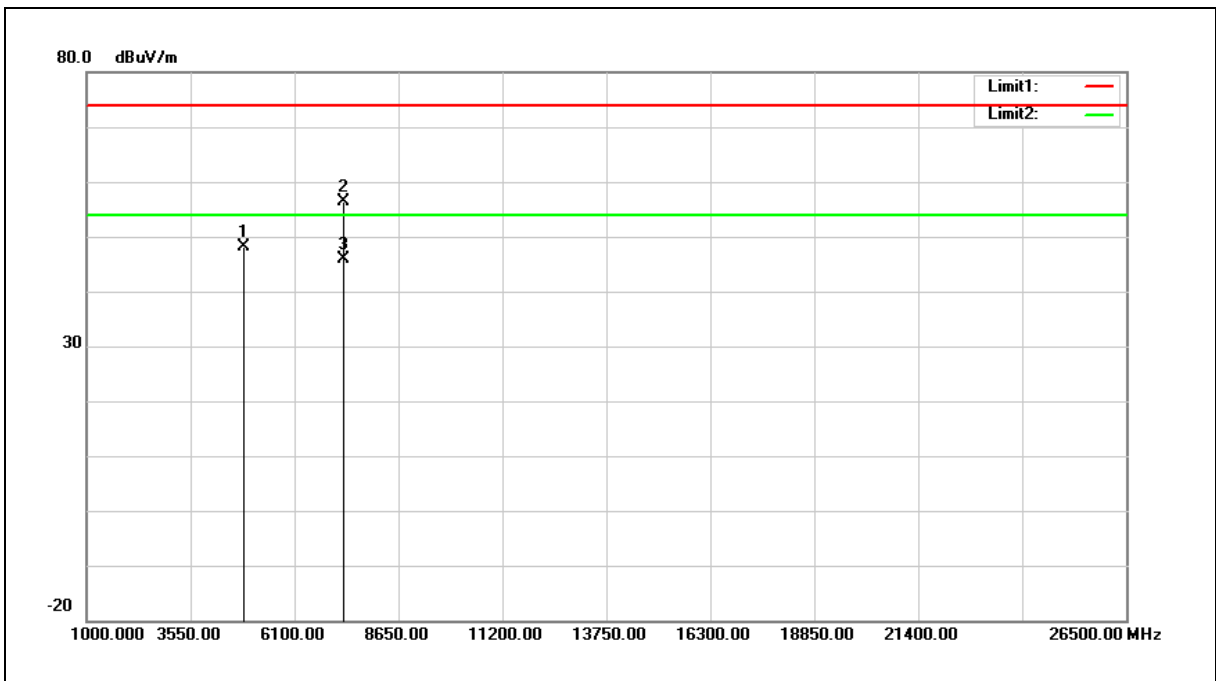

No.	Frequency (MHz)	Reading (dBuV)	Correct Factor (dB/m)	Result (dBuV/m)	Limit (dBuV/m)	Margin (dB)	Remark
1	4874.000	53.06	-4.84	48.22	74.00	-25.78	peak
2	7311.000	56.63	-0.23	56.40	74.00	-17.60	peak
3	7311.000	46.03	-0.23	45.80	54.00	-8.20	AVG

Note:1.Result (dBuV/m) = Correct Factor (dB/m) + Reading(dBuV).

2.Correction factor (dB/m) = Antenna Factor (dB/m) + Cable loss (dB) – Pre-Amplifier gain (dB).

3.When the peak results are less than average limit, so not need to evaluate the average.



Standard:	FCC Part 15.247	Test Distance:	3 m
Test item:	Harmonic	Power:	DC 3.3 V
Frequency:	2462 MHz	Temp.(°C)/Hum.(%RH):	26(°C)/60 %RH
Mode:	Mode 3		
Ant.Polar.:	Horizontal		

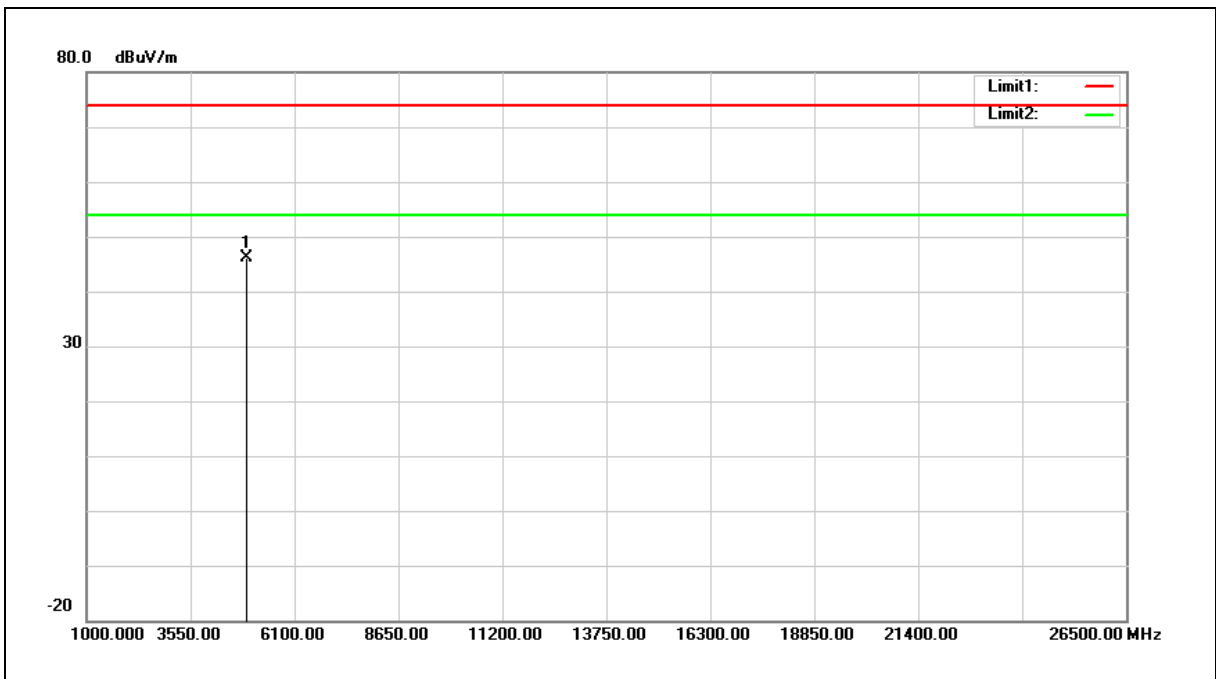

No.	Frequency (MHz)	Reading (dBuV)	Correct Factor (dB/m)	Result (dBuV/m)	Limit (dBuV/m)	Margin (dB)	Remark
1	4924.000	50.95	-4.87	46.08	74.00	-27.92	peak

Note:1.Result (dBuV/m) = Correct Factor (dB/m) + Reading(dBuV).

2.Correction factor (dB/m) = Antenna Factor (dB/m) + Cable loss (dB) – Pre-Amplifier gain (dB).

3.When the peak results are less than average limit, so not need to evaluate the average.



Standard:	FCC Part 15.247	Test Distance:	3 m
Test item:	Harmonic	Power:	DC 3.3 V
Frequency:	2462 MHz	Temp.(°C)/Hum.(%RH):	26(°C)/60 %RH
Mode:	Mode 3		
Ant.Polar.:	Vertical		

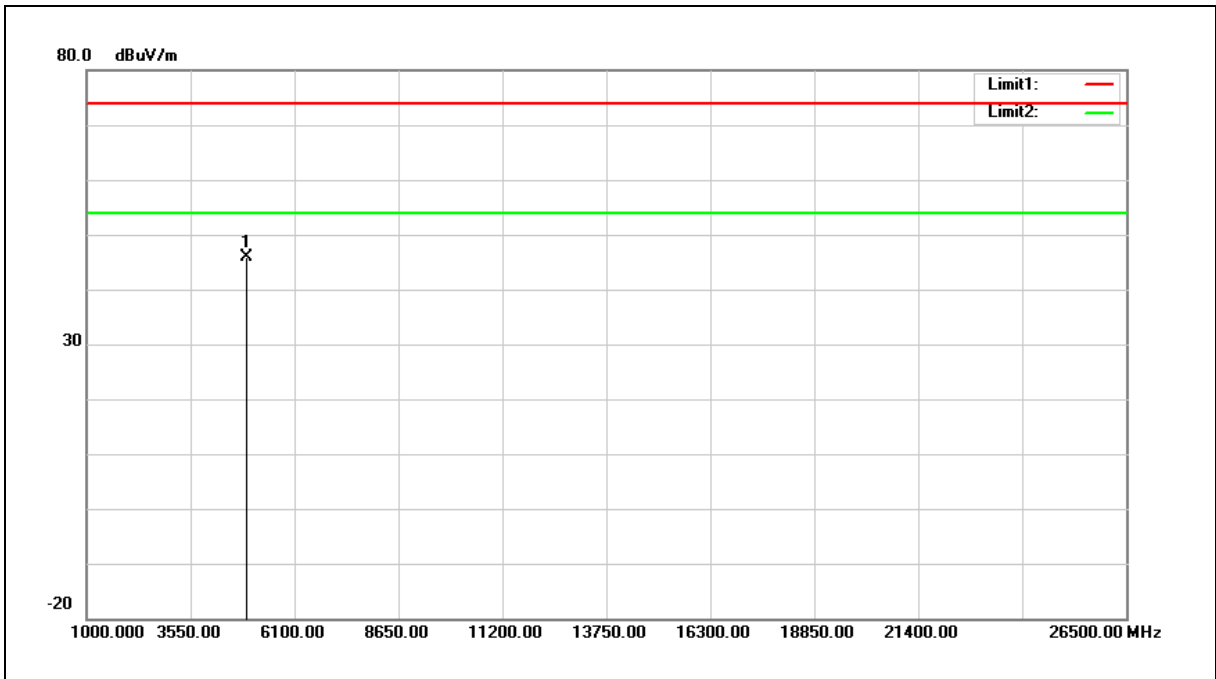

No.	Frequency (MHz)	Reading (dBuV)	Correct Factor (dB/m)	Result (dBuV/m)	Limit (dBuV/m)	Margin (dB)	Remark
1	4924.000	50.87	-4.87	46.00	74.00	-28.00	peak

Note:1.Result (dBuV/m) = Correct Factor (dB/m) + Reading(dBuV).

2.Correction factor (dB/m) = Antenna Factor (dB/m) + Cable loss (dB) – Pre-Amplifier gain (dB).

3.When the peak results are less than average limit, so not need to evaluate the average.



Standard:	FCC Part 15.247	Test Distance:	3 m
Test item:	Harmonic	Power:	DC 3.3 V
Frequency:	2412 MHz	Temp.(°C)/Hum.(%RH):	26(°C)/60 %RH
Mode:	Mode 4		
Ant.Polar.:	Horizontal		

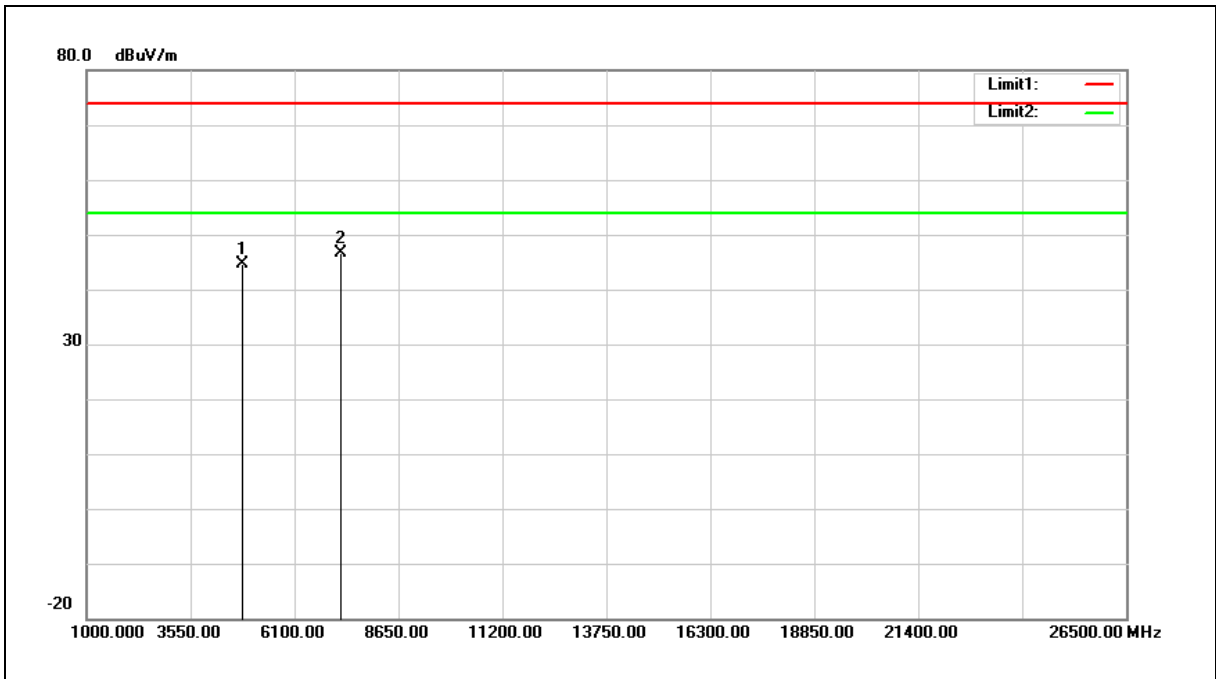

No.	Frequency (MHz)	Reading (dBuV)	Correct Factor (dB/m)	Result (dBuV/m)	Limit (dBuV/m)	Margin (dB)	Remark
1	4824.000	49.50	-4.82	44.68	74.00	-29.32	peak
2	7236.000	47.03	-0.42	46.61	74.00	-27.39	peak

Note:1.Result (dBuV/m) = Correct Factor (dB/m) + Reading(dBuV).

2.Correction factor (dB/m) = Antenna Factor (dB/m) + Cable loss (dB) – Pre-Amplifier gain (dB).

3.When the peak results are less than average limit, so not need to evaluate the average.



Standard:	FCC Part 15.247	Test Distance:	3 m
Test item:	Harmonic	Power:	DC 3.3 V
Frequency:	2412 MHz	Temp.(°C)/Hum.(%RH):	26(°C)/60 %RH
Mode:	Mode 4		
Ant.Polar.:	Vertical		

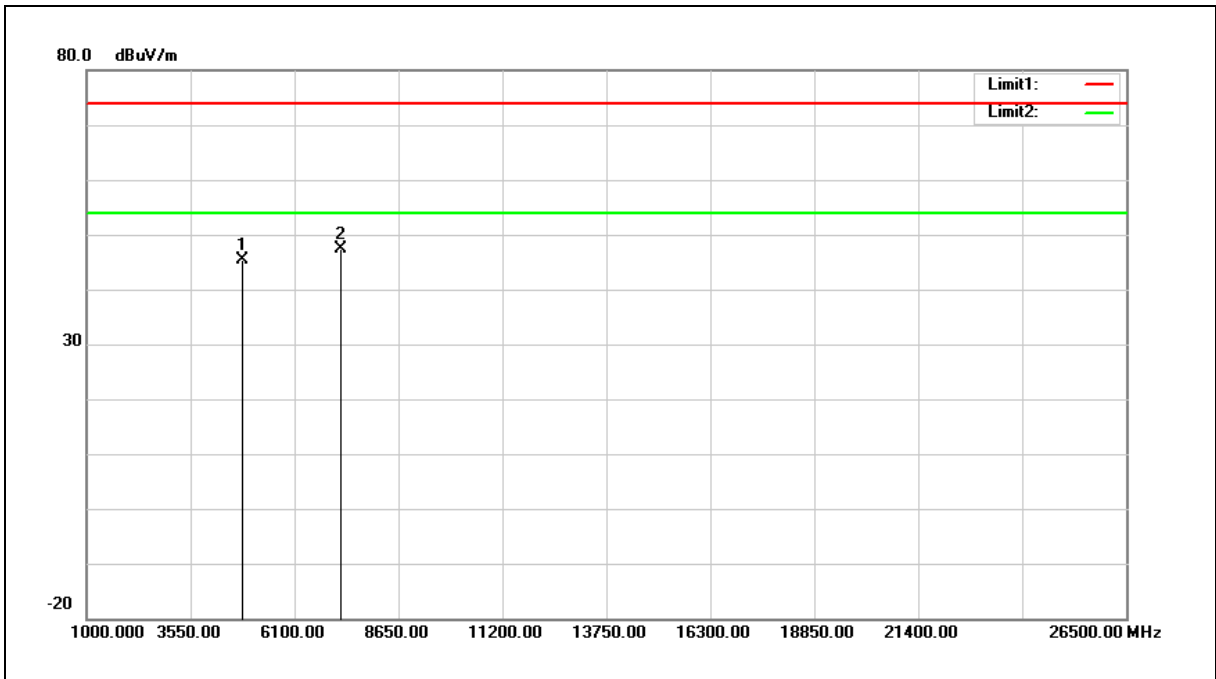

No.	Frequency (MHz)	Reading (dBuV)	Correct Factor (dB/m)	Result (dBuV/m)	Limit (dBuV/m)	Margin (dB)	Remark
1	4824.000	50.11	-4.82	45.29	74.00	-28.71	peak
2	7236.000	47.92	-0.42	47.50	74.00	-26.50	peak

Note:1.Result (dBuV/m) = Correct Factor (dB/m) + Reading(dBuV).

2.Correction factor (dB/m) = Antenna Factor (dB/m) + Cable loss (dB) – Pre-Amplifier gain (dB).

3.When the peak results are less than average limit, so not need to evaluate the average.



Standard:	FCC Part 15.247	Test Distance:	3 m
Test item:	Harmonic	Power:	DC 3.3 V
Frequency:	2437 MHz	Temp.(°C)/Hum.(%RH):	26(°C)/60 %RH
Mode:	Mode 4		
Ant.Polar.:	Horizontal		

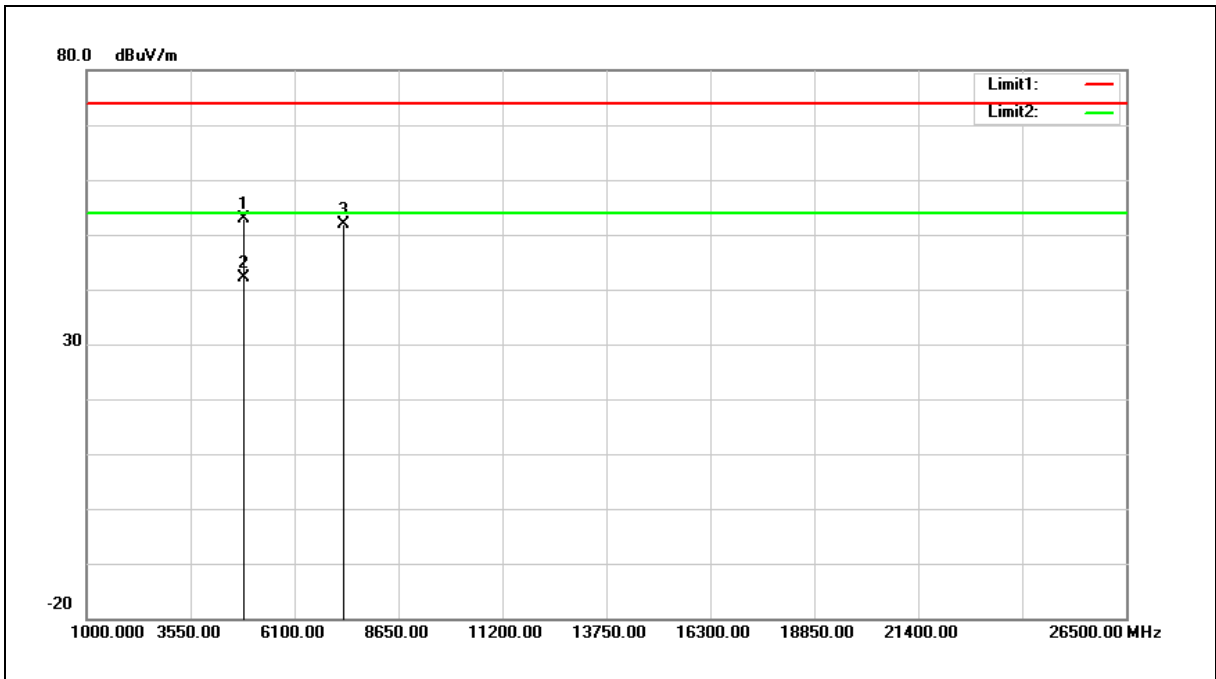

No.	Frequency (MHz)	Reading (dBuV)	Correct Factor (dB/m)	Result (dBuV/m)	Limit (dBuV/m)	Margin (dB)	Remark
1	4874.000	57.73	-4.84	52.89	74.00	-21.11	peak
2	4874.000	46.87	-4.84	42.03	54.00	-11.97	AVG
3	7311.000	52.07	-0.23	51.84	74.00	-22.16	peak

Note:1.Result (dBuV/m) = Correct Factor (dB/m) + Reading(dBuV).

2.Correction factor (dB/m) = Antenna Factor (dB/m) + Cable loss (dB) – Pre-Amplifier gain (dB).

3.When the peak results are less than average limit, so not need to evaluate the average.



Standard:	FCC Part 15.247	Test Distance:	3 m
Test item:	Harmonic	Power:	DC 3.3 V
Frequency:	2437 MHz	Temp.(°C)/Hum.(%RH):	26(°C)/60 %RH
Mode:	Mode 4		
Ant.Polar.:	Vertical		

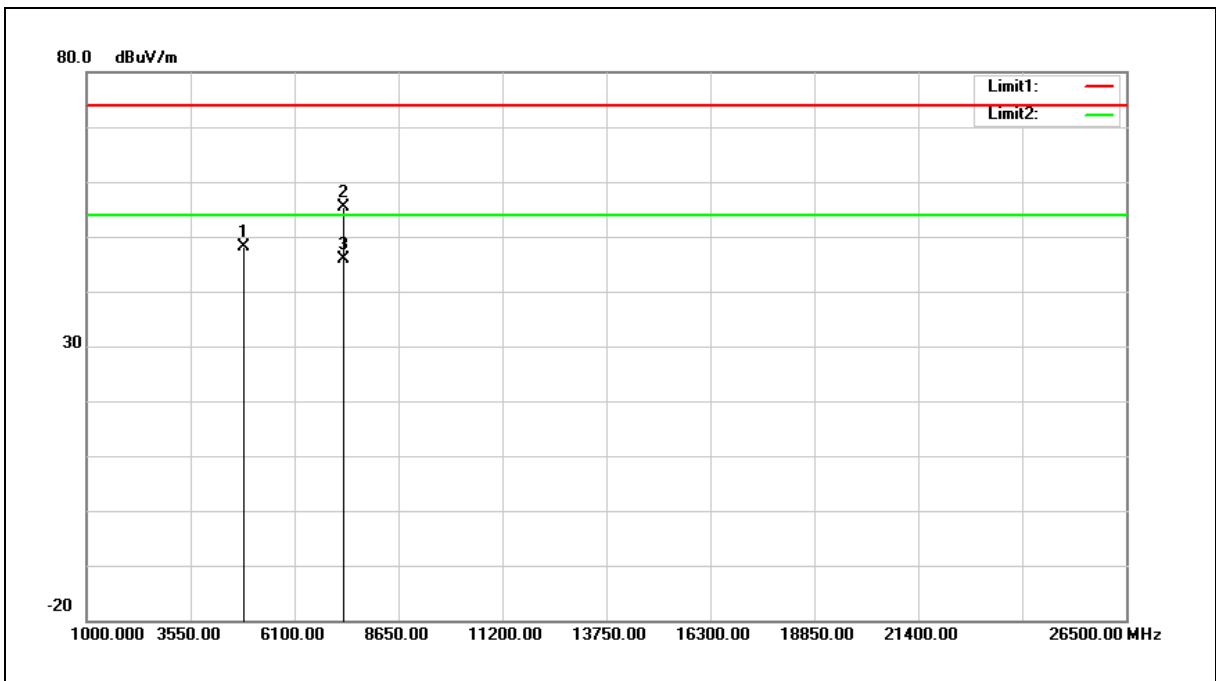

No.	Frequency (MHz)	Reading (dBuV)	Correct Factor (dB/m)	Result (dBuV/m)	Limit (dBuV/m)	Margin (dB)	Remark
1	4874.000	52.97	-4.84	48.13	74.00	-25.87	peak
2	7311.000	55.65	-0.23	55.42	74.00	-18.58	peak
3	7311.000	46.05	-0.23	45.82	54.00	-8.18	AVG

Note:1.Result (dBuV/m) = Correct Factor (dB/m) + Reading(dBuV).

2.Correction factor (dB/m) = Antenna Factor (dB/m) + Cable loss (dB) – Pre-Amplifier gain (dB).

3.When the peak results are less than average limit, so not need to evaluate the average.



Standard:	FCC Part 15.247	Test Distance:	3 m
Test item:	Harmonic	Power:	DC 3.3 V
Frequency:	2462 MHz	Temp.(°C)/Hum.(%RH):	26(°C)/60 %RH
Mode:	Mode 4		
Ant.Polar.:	Horizontal		

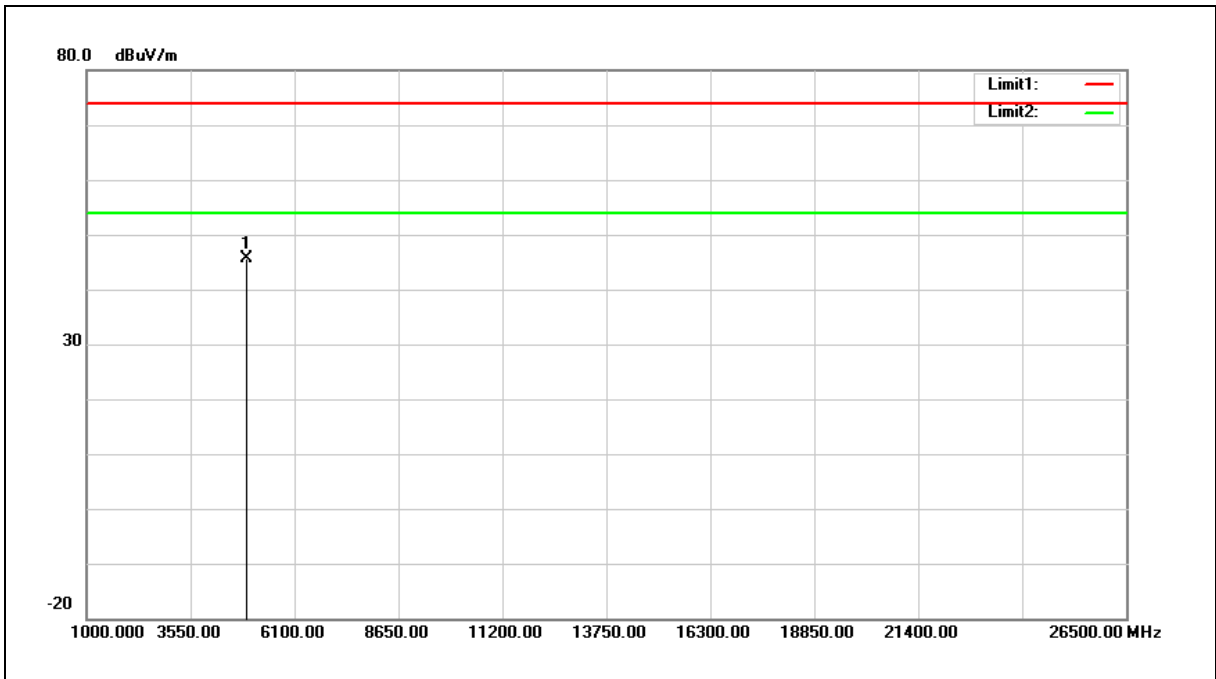

No.	Frequency (MHz)	Reading (dBuV)	Correct Factor (dB/m)	Result (dBuV/m)	Limit (dBuV/m)	Margin (dB)	Remark
1	4924.000	50.58	-4.87	45.71	74.00	-28.29	peak

Note:1.Result (dBuV/m) = Correct Factor (dB/m) + Reading(dBuV).

2.Correction factor (dB/m) = Antenna Factor (dB/m) + Cable loss (dB) – Pre-Amplifier gain (dB).

3.When the peak results are less than average limit, so not need to evaluate the average.



Standard:	FCC Part 15.247	Test Distance:	3 m
Test item:	Harmonic	Power:	DC 3.3 V
Frequency:	2462 MHz	Temp.(°C)/Hum.(%RH):	26(°C)/60 %RH
Mode:	Mode 4		
Ant.Polar.:	Vertical		

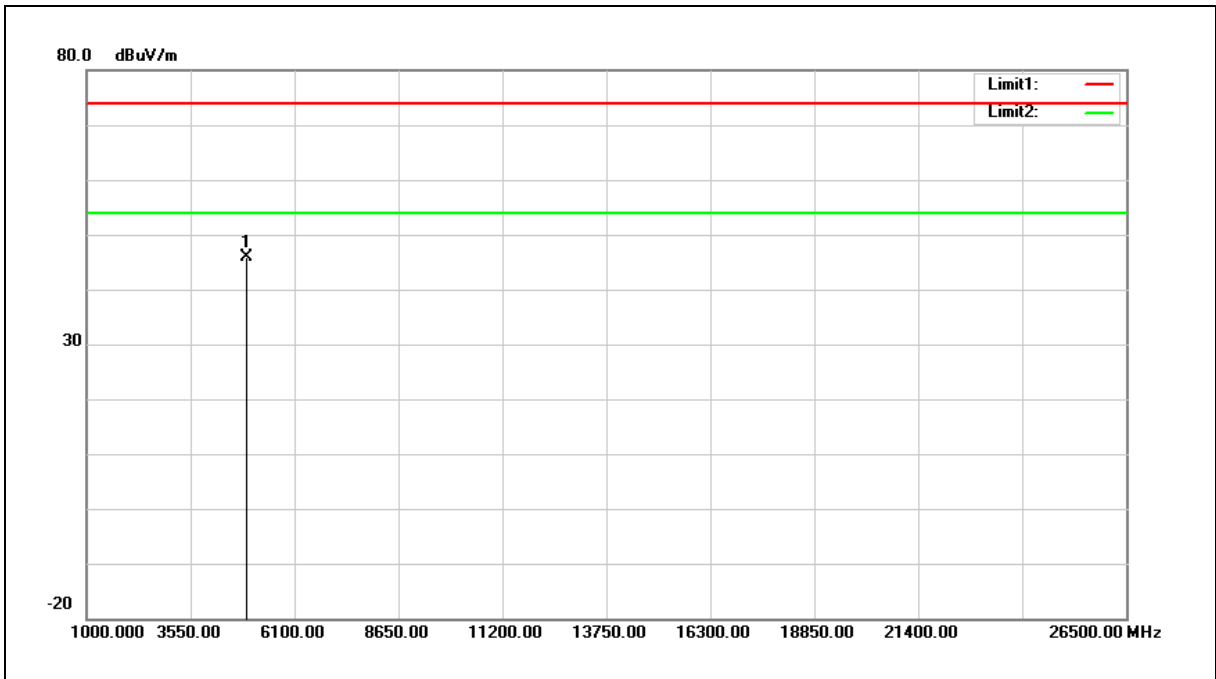

No.	Frequency (MHz)	Reading (dBuV)	Correct Factor (dB/m)	Result (dBuV/m)	Limit (dBuV/m)	Margin (dB)	Remark
1	4924.000	50.75	-4.87	45.88	74.00	-28.12	peak

Note:1.Result (dBuV/m) = Correct Factor (dB/m) + Reading(dBuV).

2.Correction factor (dB/m) = Antenna Factor (dB/m) + Cable loss (dB) – Pre-Amplifier gain (dB).

3.When the peak results are less than average limit, so not need to evaluate the average.



Standard:	FCC Part 15.247	Test Distance:	3 m
Test item:	Harmonic	Power:	DC 3.3 V
Frequency:	2422 MHz	Temp.(°C)/Hum.(%RH):	26(°C)/60 %RH
Mode:	Mode 5		
Ant.Polar.:	Horizontal		

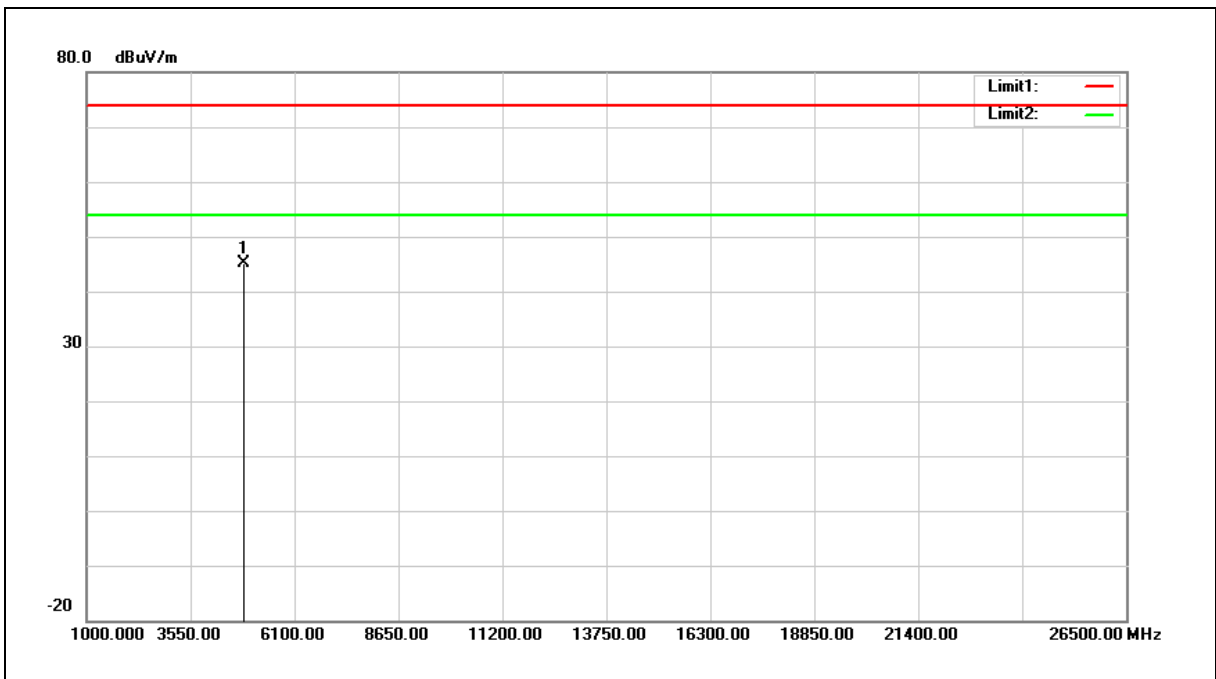

No.	Frequency (MHz)	Reading (dBuV)	Correct Factor (dB/m)	Result (dBuV/m)	Limit (dBuV/m)	Margin (dB)	Remark
1	4844.000	50.01	-4.83	45.18	74.00	-28.82	peak

Note:1.Result (dBuV/m) = Correct Factor (dB/m) + Reading(dBuV).

2.Correction factor (dB/m) = Antenna Factor (dB/m) + Cable loss (dB) – Pre-Amplifier gain (dB).

3.When the peak results are less than average limit, so not need to evaluate the average.



Standard:	FCC Part 15.247	Test Distance:	3 m
Test item:	Harmonic	Power:	DC 3.3 V
Frequency:	2422 MHz	Temp.(°C)/Hum.(%RH):	26(°C)/60 %RH
Mode:	Mode 5		
Ant.Polar.:	Vertical		

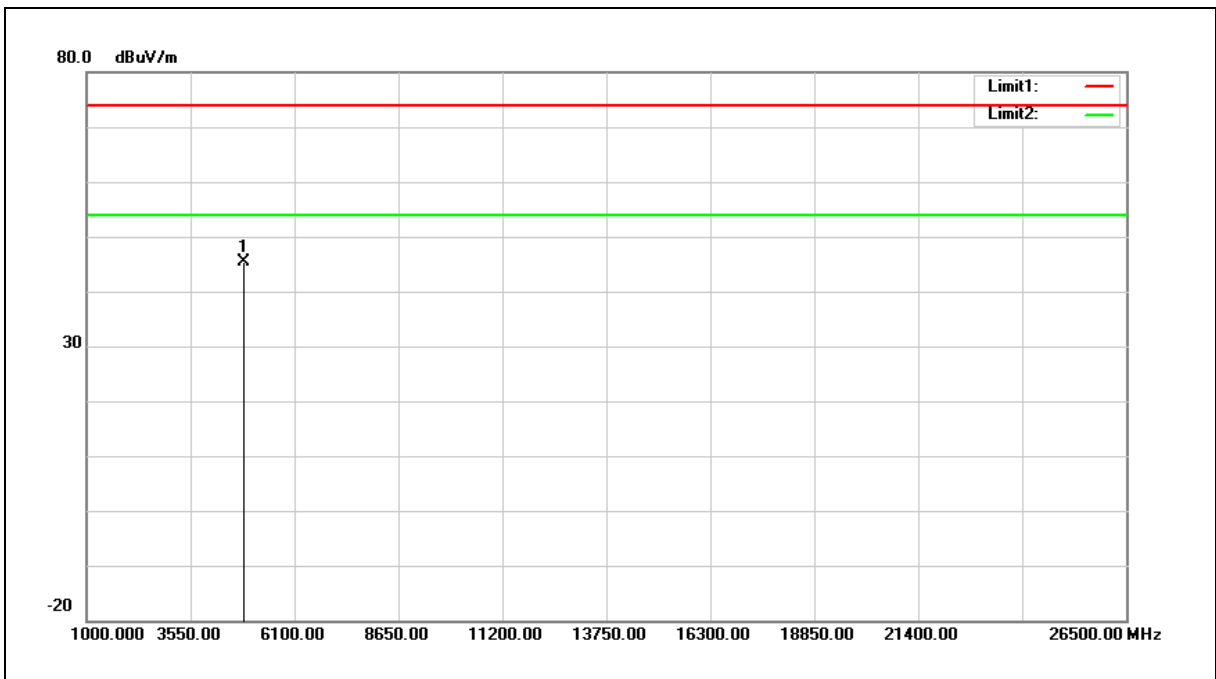

No.	Frequency (MHz)	Reading (dBuV)	Correct Factor (dB/m)	Result (dBuV/m)	Limit (dBuV/m)	Margin (dB)	Remark
1	4844.000	50.20	-4.83	45.37	74.00	-28.63	peak

- Note:1.Result (dBuV/m) = Correct Factor (dB/m) + Reading(dBuV).
- 2.Correction factor (dB/m) = Antenna Factor (dB/m) + Cable loss (dB) – Pre-Amplifier gain (dB).
- 3.When the peak results are less than average limit, so not need to evaluate the average.



Standard:	FCC Part 15.247	Test Distance:	3 m
Test item:	Harmonic	Power:	DC 3.3 V
Frequency:	2437 MHz	Temp.(°C)/Hum.(%RH):	26(°C)/60 %RH
Mode:	Mode 5		
Ant.Polar.:	Horizontal		

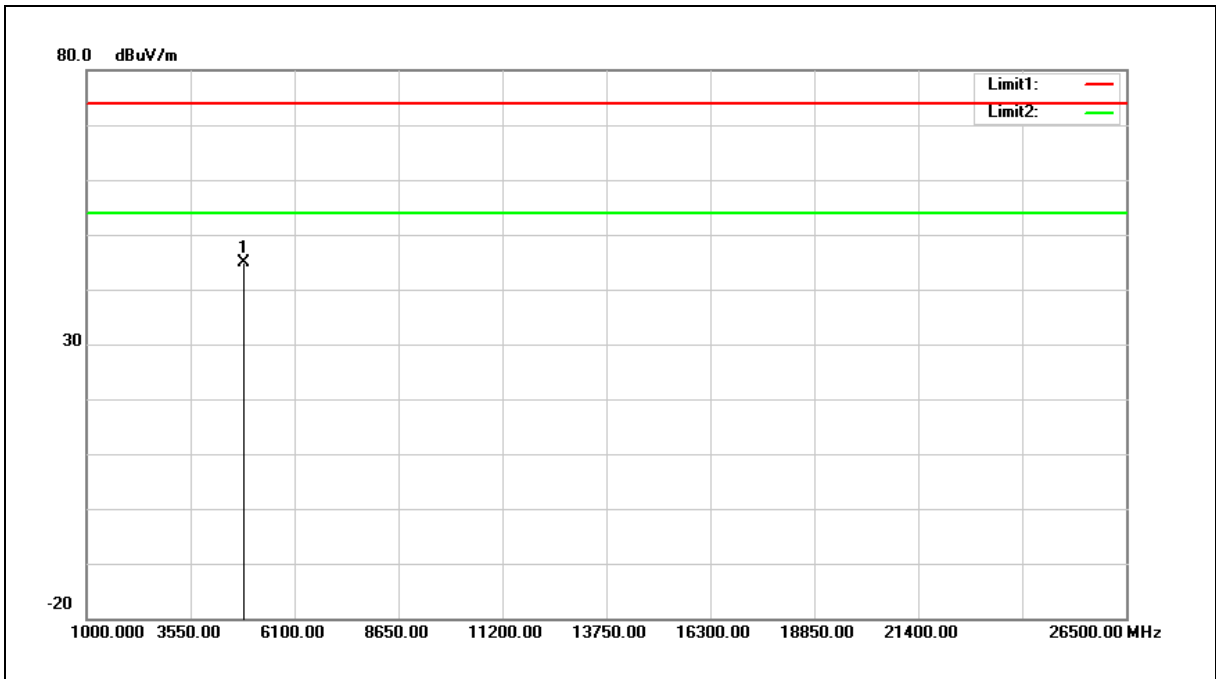

No.	Frequency (MHz)	Reading (dBuV)	Correct Factor (dB/m)	Result (dBuV/m)	Limit (dBuV/m)	Margin (dB)	Remark
1	4874.000	49.75	-4.84	44.91	74.00	-29.09	peak

Note:1.Result (dBuV/m) = Correct Factor (dB/m) + Reading(dBuV).

2.Correction factor (dB/m) = Antenna Factor (dB/m) + Cable loss (dB) – Pre-Amplifier gain (dB).

3.When the peak results are less than average limit, so not need to evaluate the average.



Standard:	FCC Part 15.247	Test Distance:	3 m
Test item:	Harmonic	Power:	DC 3.3 V
Frequency:	2437 MHz	Temp.(°C)/Hum.(%RH):	26(°C)/60 %RH
Mode:	Mode 5		
Ant.Polar.:	Vertical		

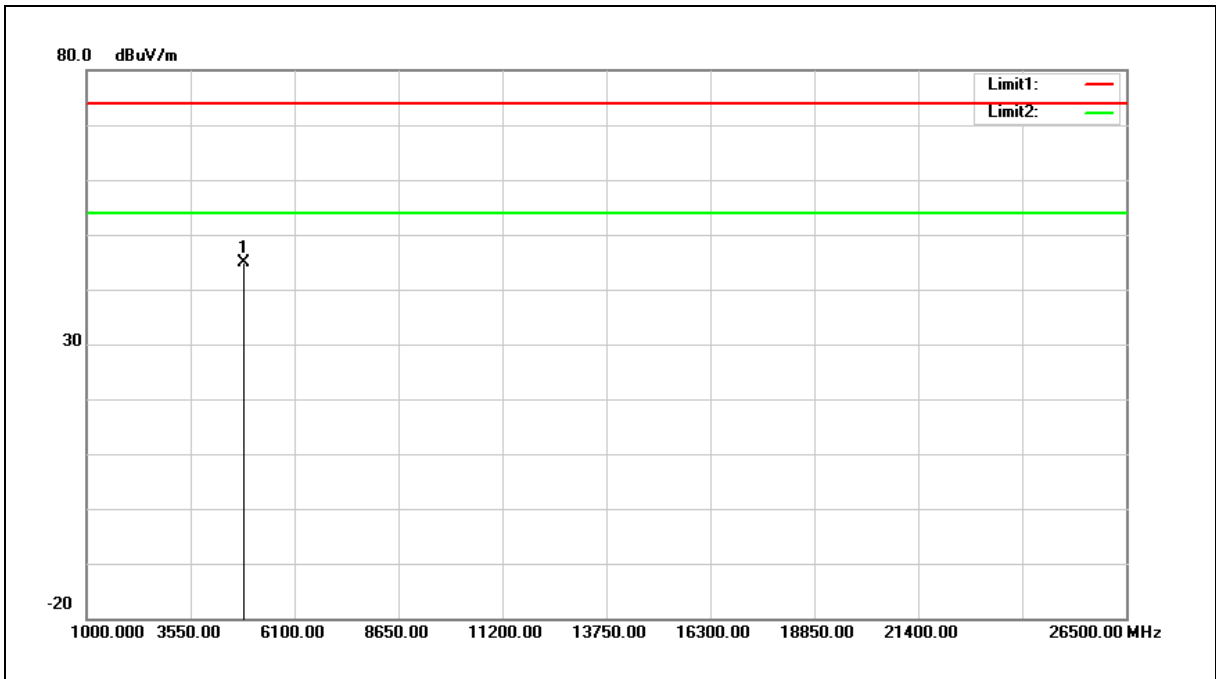

No.	Frequency (MHz)	Reading (dBuV)	Correct Factor (dB/m)	Result (dBuV/m)	Limit (dBuV/m)	Margin (dB)	Remark
1	4874.000	49.73	-4.84	44.89	74.00	-29.11	peak

Note:1.Result (dBuV/m) = Correct Factor (dB/m) + Reading(dBuV).

2.Correction factor (dB/m) = Antenna Factor (dB/m) + Cable loss (dB) – Pre-Amplifier gain (dB).

3.When the peak results are less than average limit, so not need to evaluate the average.



Standard:	FCC Part 15.247	Test Distance:	3 m
Test item:	Harmonic	Power:	DC 3.3 V
Frequency:	2452 MHz	Temp.(°C)/Hum.(%RH):	26(°C)/60 %RH
Mode:	Mode 5		
Ant.Polar.:	Horizontal		

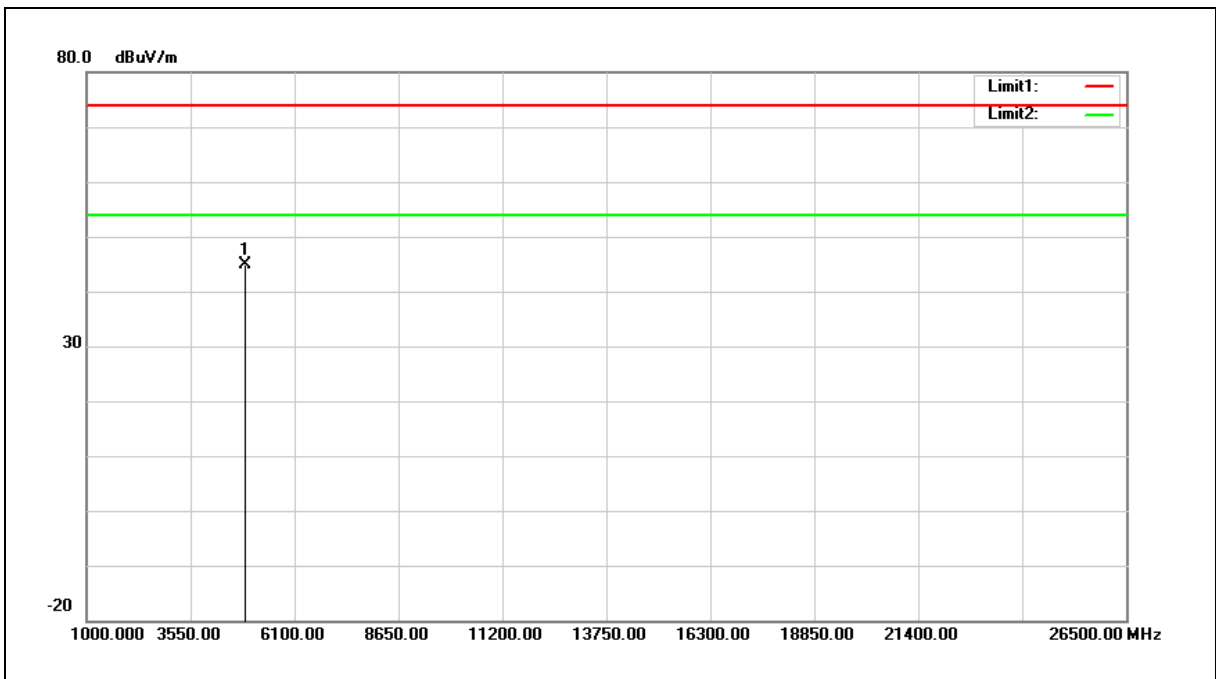

No.	Frequency (MHz)	Reading (dBuV)	Correct Factor (dB/m)	Result (dBuV/m)	Limit (dBuV/m)	Margin (dB)	Remark
1	4904.000	49.75	-4.86	44.89	74.00	-29.11	peak

Note:1.Result (dBuV/m) = Correct Factor (dB/m) + Reading(dBuV).

2.Correction factor (dB/m) = Antenna Factor (dB/m) + Cable loss (dB) – Pre-Amplifier gain (dB).

3.When the peak results are less than average limit, so not need to evaluate the average.



Standard:	FCC Part 15.247	Test Distance:	3 m
Test item:	Harmonic	Power:	DC 3.3 V
Frequency:	2452 MHz	Temp.(°C)/Hum.(%RH):	26(°C)/60 %RH
Mode:	Mode 5		
Ant.Polar.:	Vertical		

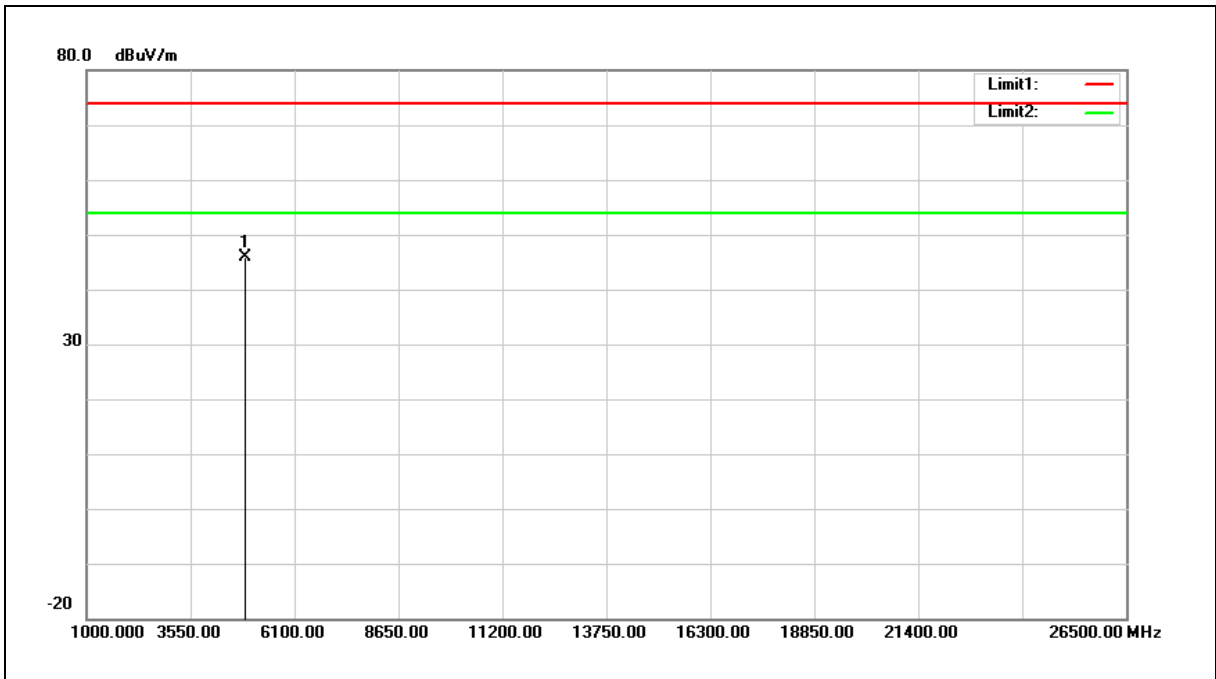

No.	Frequency (MHz)	Reading (dBuV)	Correct Factor (dB/m)	Result (dBuV/m)	Limit (dBuV/m)	Margin (dB)	Remark
1	4904.000	50.86	-4.86	46.00	74.00	-28.00	peak

Note:1.Result (dBuV/m) = Correct Factor (dB/m) + Reading(dBuV).

2.Correction factor (dB/m) = Antenna Factor (dB/m) + Cable loss (dB) – Pre-Amplifier gain (dB).

3.When the peak results are less than average limit, so not need to evaluate the average.



Band Edge

Power setting 1_Antenna Type: PCB Trace Antenna

Standard:	FCC Part 15.247	Test Distance:	3 m
Test item:	Band edge	Power:	DC 3.3 V
Frequency:	2412 MHz	Temp.(°C)/Hum.(%RH):	26(°C)/60 %RH
Mode:	Mode 2		
Ant.Polar.:	Horizontal		

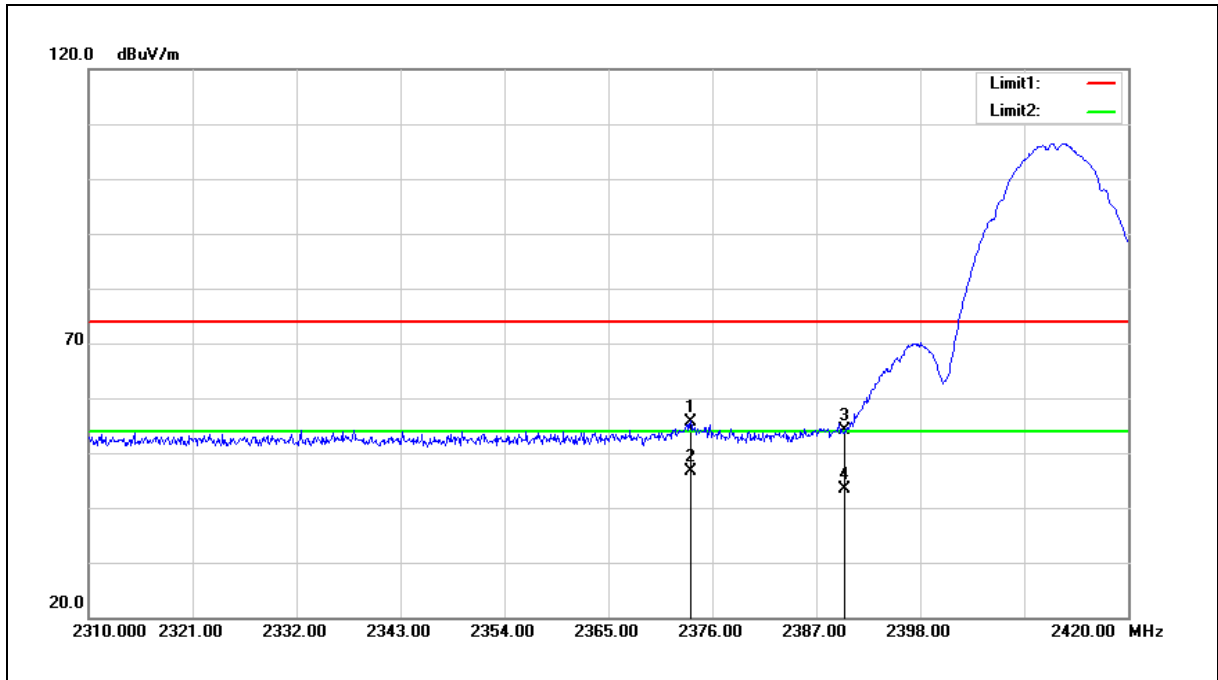

No.	Frequency (MHz)	Reading (dBuV)	Correct Factor (dB/m)	Result (dBuV/m)	Limit (dBuV/m)	Margin (dB)	Remark
1	2373.690	52.26	3.49	55.75	74.00	-18.25	peak
2	2373.690	43.05	3.49	46.54	54.00	-7.46	AVG
3	2390.000	50.72	3.53	54.25	74.00	-19.75	peak
4	2390.000	39.87	3.53	43.40	54.00	-10.60	AVG

Note:1.Result (dBuV/m) = Correct Factor (dB/m) + Reading(dBuV).

2.Correction factor (dB/m) = Antenna Factor (dB/m) + Cable loss (dB) – Pre-Amplifier gain (dB).

3.When the peak results are less than average limit, so not need to evaluate the average.



Standard:	FCC Part 15.247	Test Distance:	3 m
Test item:	Band edge	Power:	DC 3.3 V
Frequency:	2412 MHz	Temp.(°C)/Hum.(%RH):	26(°C)/60 %RH
Mode:	Mode 2		
Ant.Polar.:	Vertical		

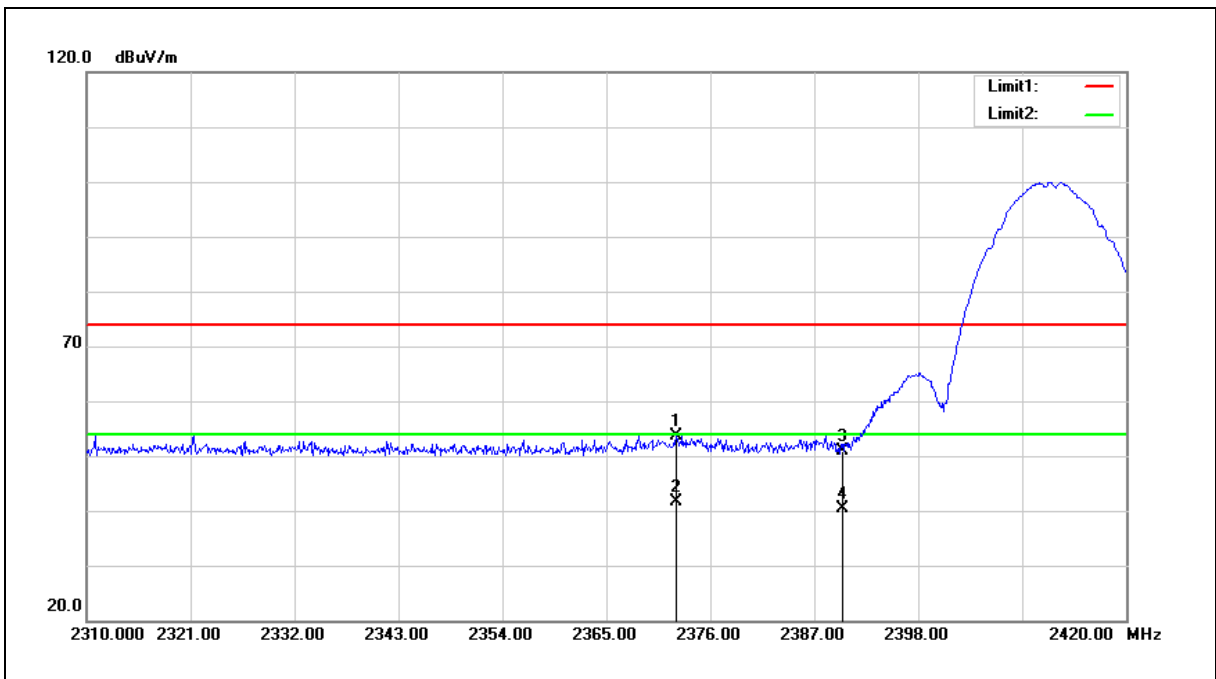

No.	Frequency (MHz)	Reading (dBuV)	Correct Factor (dB/m)	Result (dBuV/m)	Limit (dBuV/m)	Margin (dB)	Remark
1	2372.370	50.23	3.49	53.72	74.00	-20.28	peak
2	2372.370	38.26	3.49	41.75	54.00	-12.25	AVG
3	2390.000	47.34	3.53	50.87	74.00	-23.13	peak
4	2390.000	36.97	3.53	40.50	54.00	-13.50	AVG

Note:1.Result (dBuV/m) = Correct Factor (dB/m) + Reading(dBuV).

2.Correction factor (dB/m) = Antenna Factor (dB/m) + Cable loss (dB) – Pre-Amplifier gain (dB).

3.When the peak results are less than average limit, so not need to evaluate the average.

Standard:	FCC Part 15.247	Test Distance:	3 m
Test item:	Band edge	Power:	DC 3.3 V
Frequency:	2437 MHz	Temp.(°C)/Hum.(%RH):	26(°C)/60 %RH
Mode:	Mode 2		
Ant.Polar.:	Horizontal		

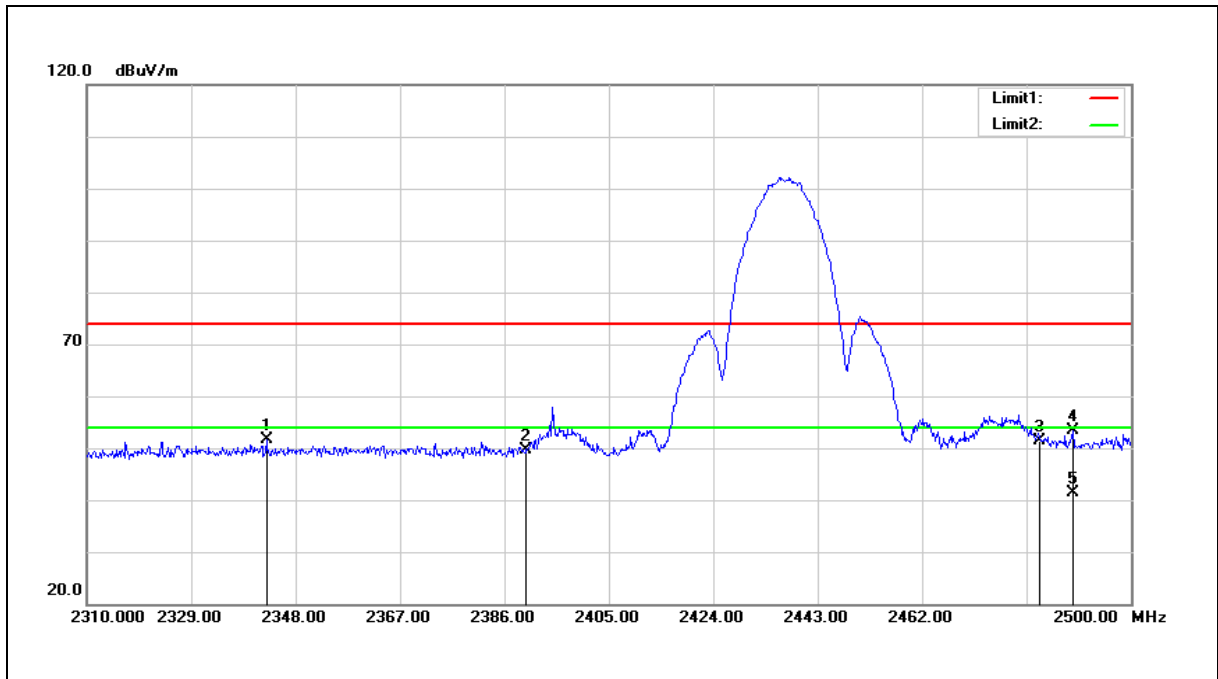

No.	Frequency (MHz)	Reading (dBuV)	Correct Factor (dB/m)	Result (dBuV/m)	Limit (dBuV/m)	Margin (dB)	Remark
1	2342.680	61.51	-9.80	51.71	74.00	-22.29	peak
2	2390.000	59.28	-9.62	49.66	74.00	-24.34	peak
3	2483.500	60.74	-9.37	51.37	74.00	-22.63	peak
4	2489.550	62.69	-9.35	53.34	74.00	-20.66	peak
5	2489.550	50.67	-9.35	41.32	54.00	-12.68	AVG

Note:1.Result (dBuV/m) = Correct Factor (dB/m) + Reading(dBuV).

2.Correction factor (dB/m) = Antenna Factor (dB/m) + Cable loss (dB) – Pre-Amplifier gain (dB).

3.When the peak results are less than average limit, so not need to evaluate the average.



Standard:	FCC Part 15.247	Test Distance:	3 m
Test item:	Band edge	Power:	DC 3.3 V
Frequency:	2437 MHz	Temp.(°C)/Hum.(%RH):	26(°C)/60 %RH
Mode:	Mode 2		
Ant.Polar.:	Vertical		

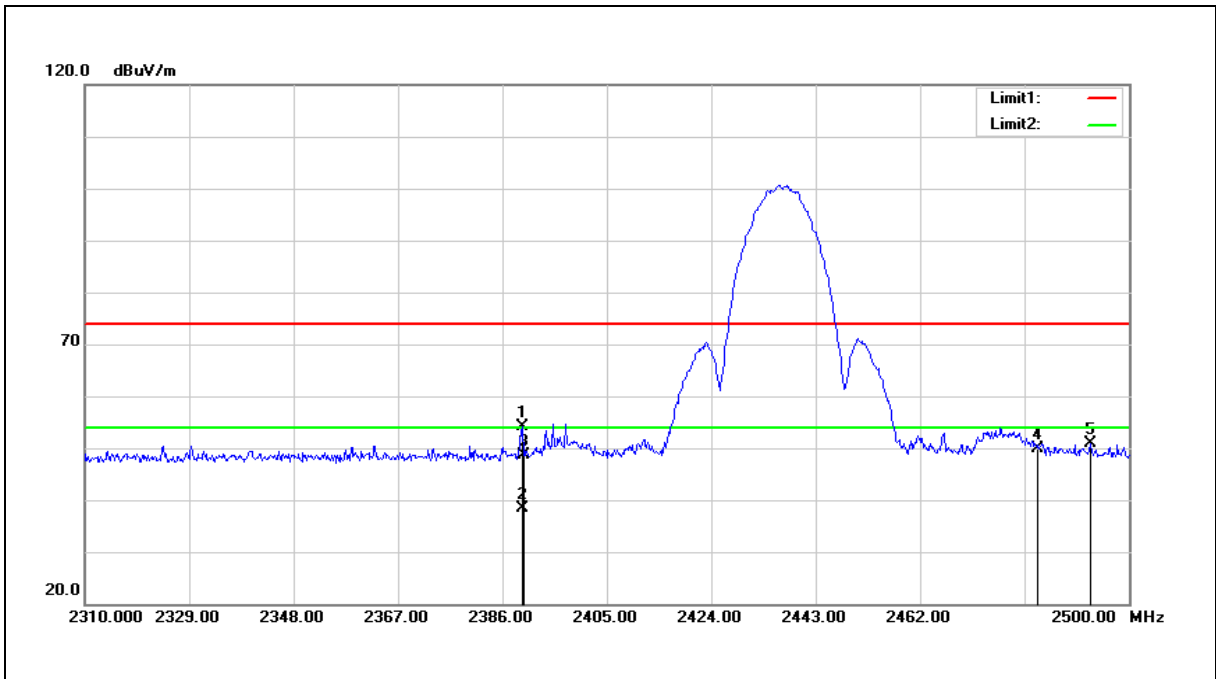

No.	Frequency (MHz)	Reading (dBuV)	Correct Factor (dB/m)	Result (dBuV/m)	Limit (dBuV/m)	Margin (dB)	Remark
1	2389.610	63.78	-9.62	54.16	74.00	-19.84	peak
2	2389.610	47.91	-9.62	38.29	54.00	-15.71	AVG
3	2390.000	58.21	-9.62	48.59	74.00	-25.41	peak
4	2483.500	59.26	-9.37	49.89	74.00	-24.11	peak
5	2492.970	60.25	-9.35	50.90	74.00	-23.10	peak

Note:1.Result (dBuV/m) = Correct Factor (dB/m) + Reading(dBuV).

2.Correction factor (dB/m) = Antenna Factor (dB/m) + Cable loss (dB) – Pre-Amplifier gain (dB).

3.When the peak results are less than average limit, so not need to evaluate the average.



Standard:	FCC Part 15.247	Test Distance:	3 m
Test item:	Band edge	Power:	DC 3.3 V
Frequency:	2462 MHz	Temp.(°C)/Hum.(%RH):	26(°C)/60 %RH
Mode:	Mode 2		
Ant.Polar.:	Horizontal		

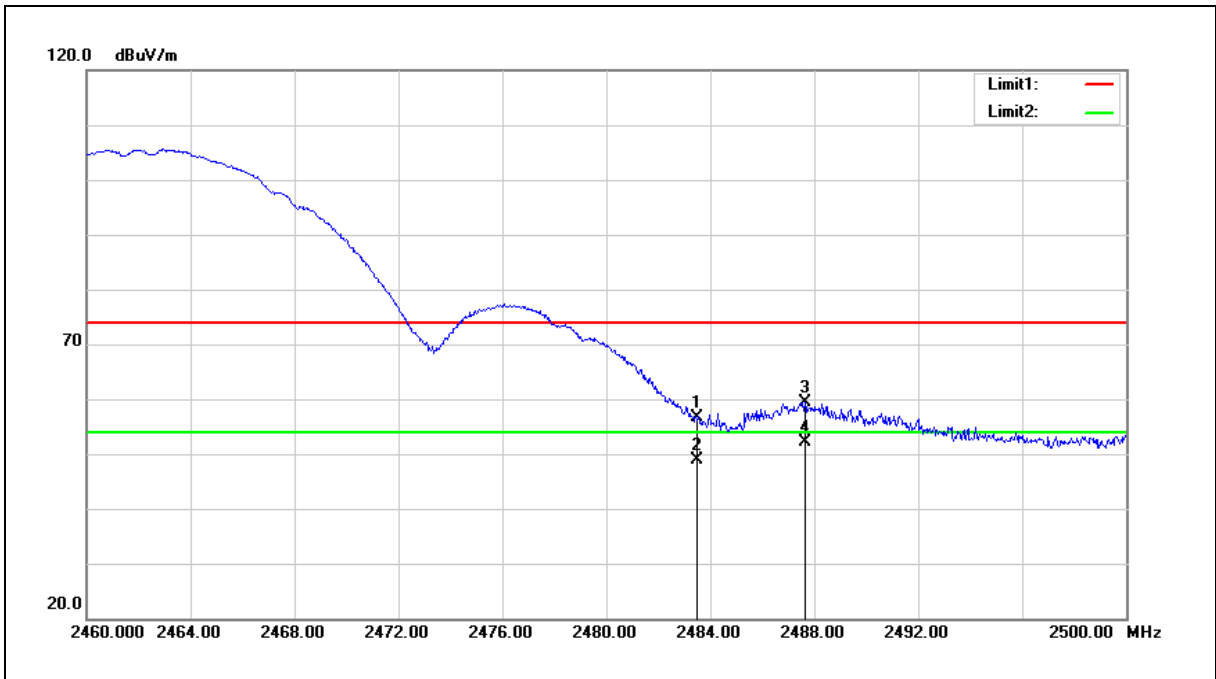

No.	Frequency (MHz)	Reading (dBuV)	Correct Factor (dB/m)	Result (dBuV/m)	Limit (dBuV/m)	Margin (dB)	Remark
1	2483.500	52.87	3.75	56.62	74.00	-17.38	peak
2	2483.500	45.07	3.75	48.82	54.00	-5.18	AVG
3	2487.640	55.58	3.76	59.34	74.00	-14.66	peak
4	2487.640	48.40	3.76	52.16	54.00	-1.84	AVG

- Note:1.Result (dBuV/m) = Correct Factor (dB/m) + Reading(dBuV).
- 2.Correction factor (dB/m) = Antenna Factor (dB/m) + Cable loss (dB) – Pre-Amplifier gain (dB).
- 3.When the peak results are less than average limit, so not need to evaluate the average.



Standard:	FCC Part 15.247	Test Distance:	3 m
Test item:	Band edge	Power:	DC 3.3 V
Frequency:	2462 MHz	Temp.(°C)/Hum.(%RH):	26(°C)/60 %RH
Mode:	Mode 2		
Ant.Polar.:	Vertical		

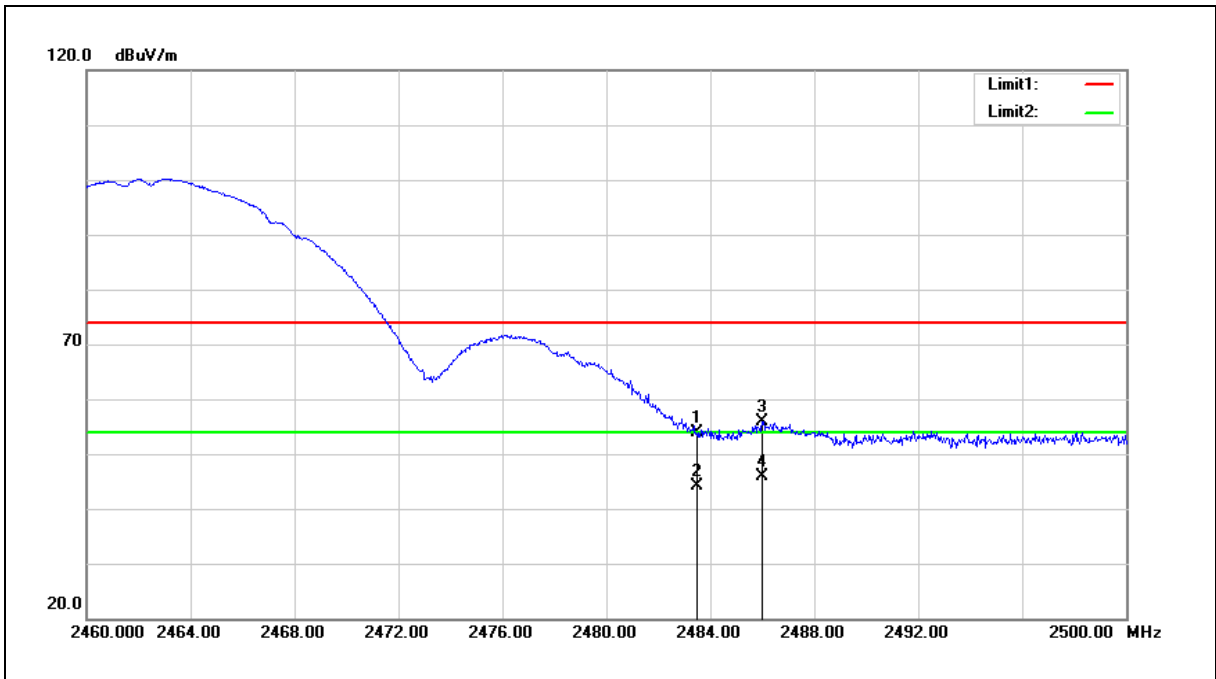

No.	Frequency (MHz)	Reading (dBuV)	Correct Factor (dB/m)	Result (dBuV/m)	Limit (dBuV/m)	Margin (dB)	Remark
1	2483.500	50.06	3.75	53.81	74.00	-20.19	peak
2	2483.500	40.43	3.75	44.18	54.00	-9.82	AVG
3	2486.000	52.22	3.76	55.98	74.00	-18.02	peak
4	2486.000	42.16	3.76	45.92	54.00	-8.08	AVG

- Note:1.Result (dBuV/m) = Correct Factor (dB/m) + Reading(dBuV).
 2.Correction factor (dB/m) = Antenna Factor (dB/m) + Cable loss (dB) – Pre-Amplifier gain (dB).
 3.When the peak results are less than average limit, so not need to evaluate the average.



Standard:	FCC Part 15.247	Test Distance:	3 m
Test item:	Band edge	Power:	DC 3.3 V
Frequency:	2412 MHz	Temp.(°C)/Hum.(%RH):	26(°C)/60 %RH
Mode:	Mode 3		
Ant.Polar.:	Horizontal		

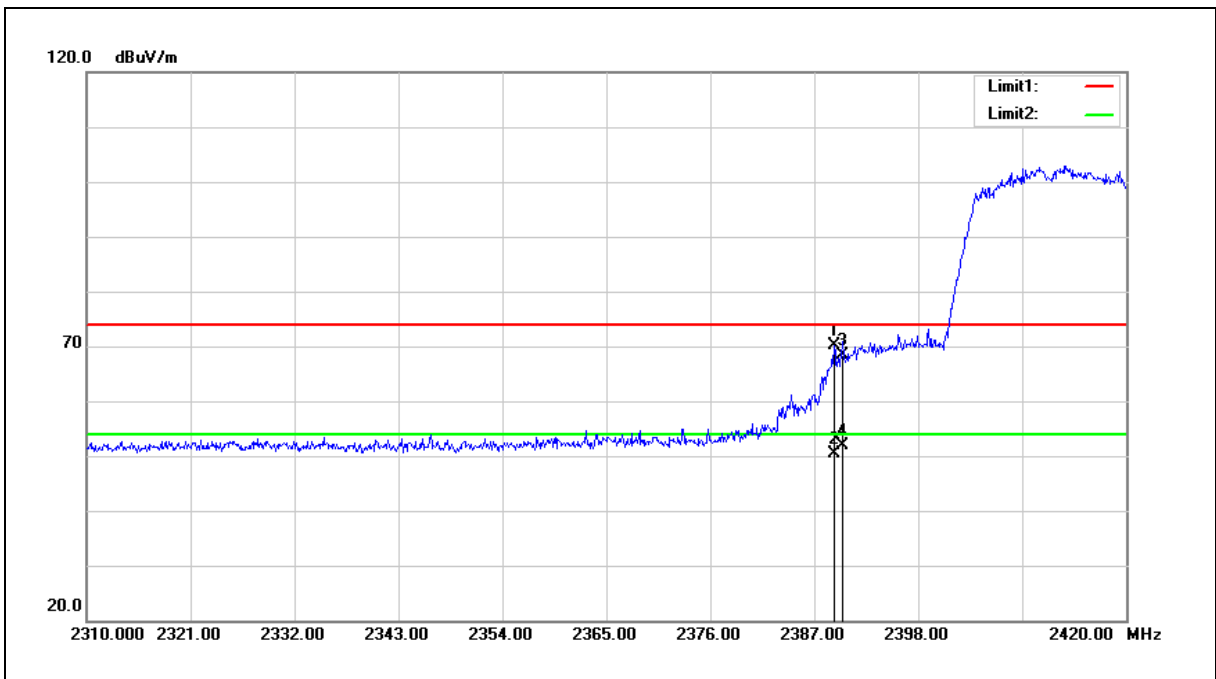

No.	Frequency (MHz)	Reading (dBuV)	Correct Factor (dB/m)	Result (dBuV/m)	Limit (dBuV/m)	Margin (dB)	Remark
1	2389.090	66.53	3.53	70.06	74.00	-3.94	peak
2	2389.090	46.73	3.53	50.26	54.00	-3.74	AVG
3	2390.000	64.95	3.53	68.48	74.00	-5.52	peak
4	2390.000	48.25	3.53	51.78	54.00	-2.22	AVG

Note:1.Result (dBuV/m) = Correct Factor (dB/m) + Reading(dBuV).

2.Correction factor (dB/m) = Antenna Factor (dB/m) + Cable loss (dB) – Pre-Amplifier gain (dB).

3.When the peak results are less than average limit, so not need to evaluate the average.



Standard:	FCC Part 15.247	Test Distance:	3 m
Test item:	Band edge	Power:	DC 3.3 V
Frequency:	2412 MHz	Temp.(°C)/Hum.(%RH):	26(°C)/60 %RH
Mode:	Mode 3		
Ant.Polar.:	Vertical		

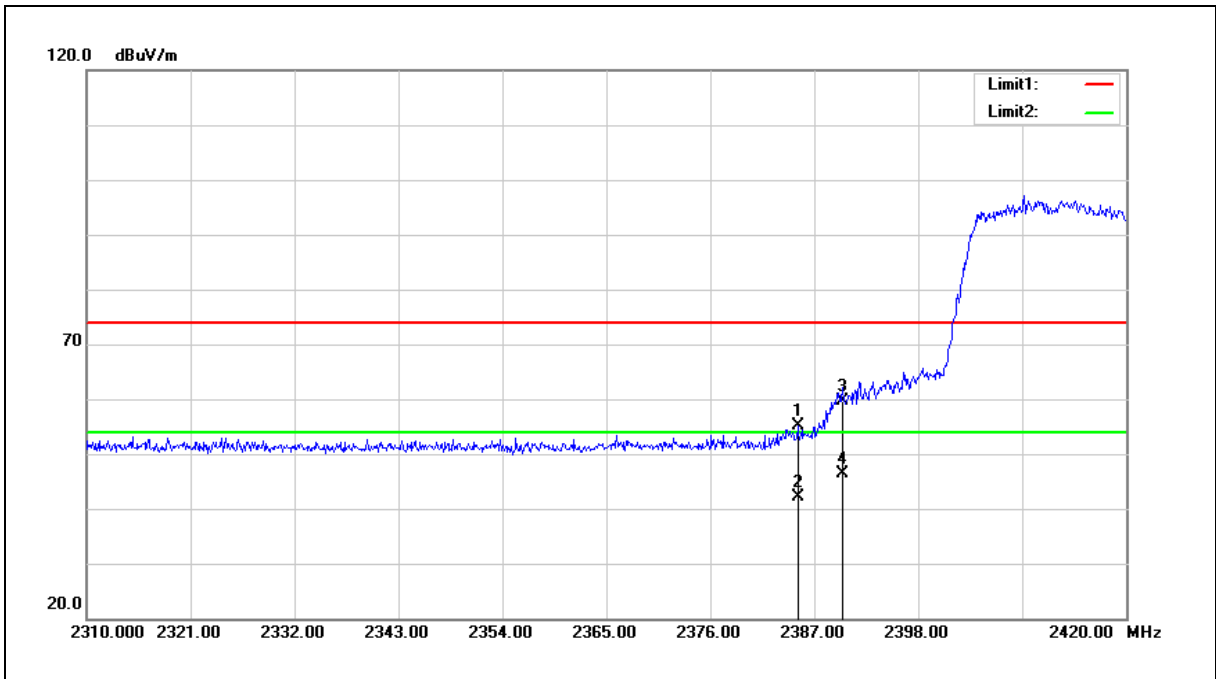

No.	Frequency (MHz)	Reading (dBuV)	Correct Factor (dB/m)	Result (dBuV/m)	Limit (dBuV/m)	Margin (dB)	Remark
1	2385.240	51.73	3.52	55.25	74.00	-18.75	peak
2	2385.240	38.56	3.52	42.08	54.00	-11.92	AVG
3	2390.000	56.05	3.53	59.58	74.00	-14.42	peak
4	2390.000	42.88	3.53	46.41	54.00	-7.59	AVG

Note:1.Result (dBuV/m) = Correct Factor (dB/m) + Reading(dBuV).

2.Correction factor (dB/m) = Antenna Factor (dB/m) + Cable loss (dB) – Pre-Amplifier gain (dB).

3.When the peak results are less than average limit, so not need to evaluate the average.



Standard:	FCC Part 15.247	Test Distance:	3 m
Test item:	Band edge	Power:	DC 3.3 V
Frequency:	2437 MHz	Temp.(°C)/Hum.(%RH):	26(°C)/60 %RH
Mode:	Mode 3		
Ant.Polar.:	Horizontal		

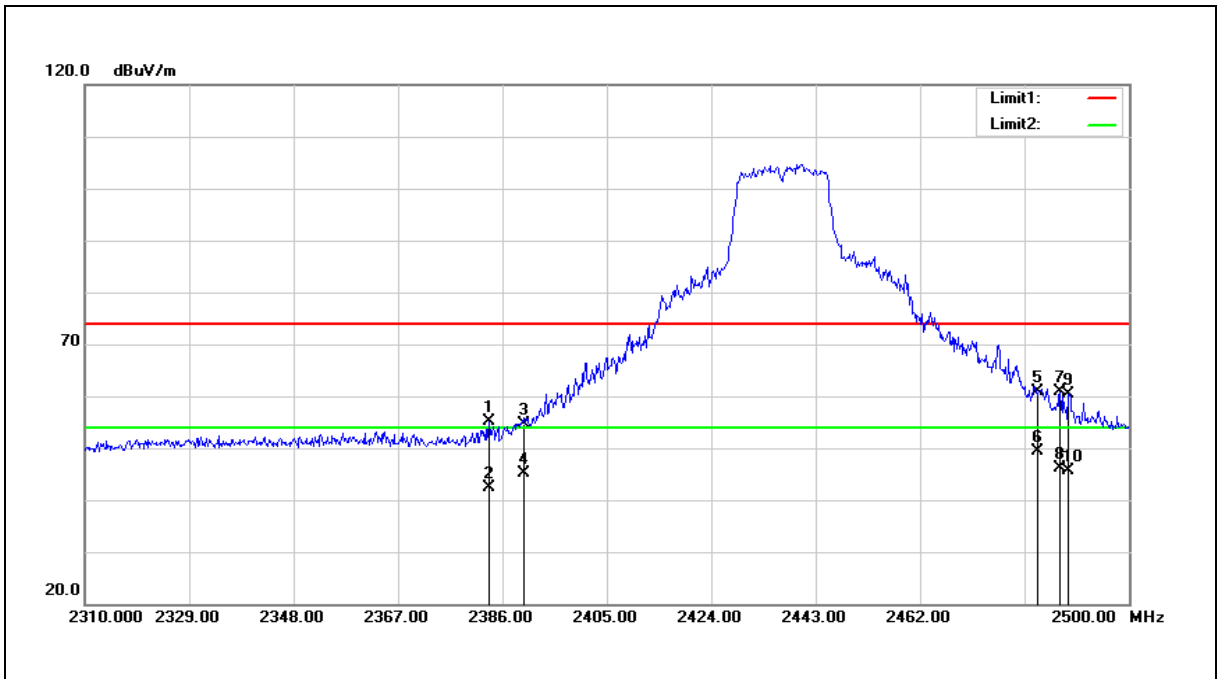



Standard:	FCC Part 15.247	Test Distance:	3 m
Test item:	Band edge	Power:	DC 3.3 V
Frequency:	2437 MHz	Temp.(°C)/Hum.(%RH):	26(°C)/60 %RH
Mode:	Mode 3		
Ant.Polar.:	Horizontal		

No.	Frequency (MHz)	Reading (dBuV)	Correct Factor (dB/m)	Result (dBuV/m)	Limit (dBuV/m)	Margin (dB)	Remark
1	2383.530	64.84	-9.65	55.19	74.00	-18.81	peak
2	2383.530	52.07	-9.65	42.42	54.00	-11.58	AVG
3	2390.000	64.28	-9.62	54.66	74.00	-19.34	peak
4	2390.000	54.82	-9.62	45.20	54.00	-8.80	AVG
5	2483.500	70.28	-9.37	60.91	74.00	-13.09	peak
6	2483.500	58.73	-9.37	49.36	54.00	-4.64	AVG
7	2487.460	70.18	-9.37	60.81	74.00	-13.19	peak
8	2487.460	55.58	-9.37	46.21	54.00	-7.79	AVG
9	2488.980	69.70	-9.36	60.34	74.00	-13.66	peak
10	2488.980	55.08	-9.36	45.72	54.00	-8.28	AVG

Note:1.Result (dBuV/m) = Correct Factor (dB/m) + Reading(dBuV).

2.Correction factor (dB/m) = Antenna Factor (dB/m) + Cable loss (dB) – Pre-Amplifier gain (dB).

3.When the peak results are less than average limit, so not need to evaluate the average.



Standard:	FCC Part 15.247	Test Distance:	3 m
Test item:	Band edge	Power:	DC 3.3 V
Frequency:	2437 MHz	Temp.(°C)/Hum.(%RH):	26(°C)/60 %RH
Mode:	Mode 3		
Ant.Polar.:	Vertical		

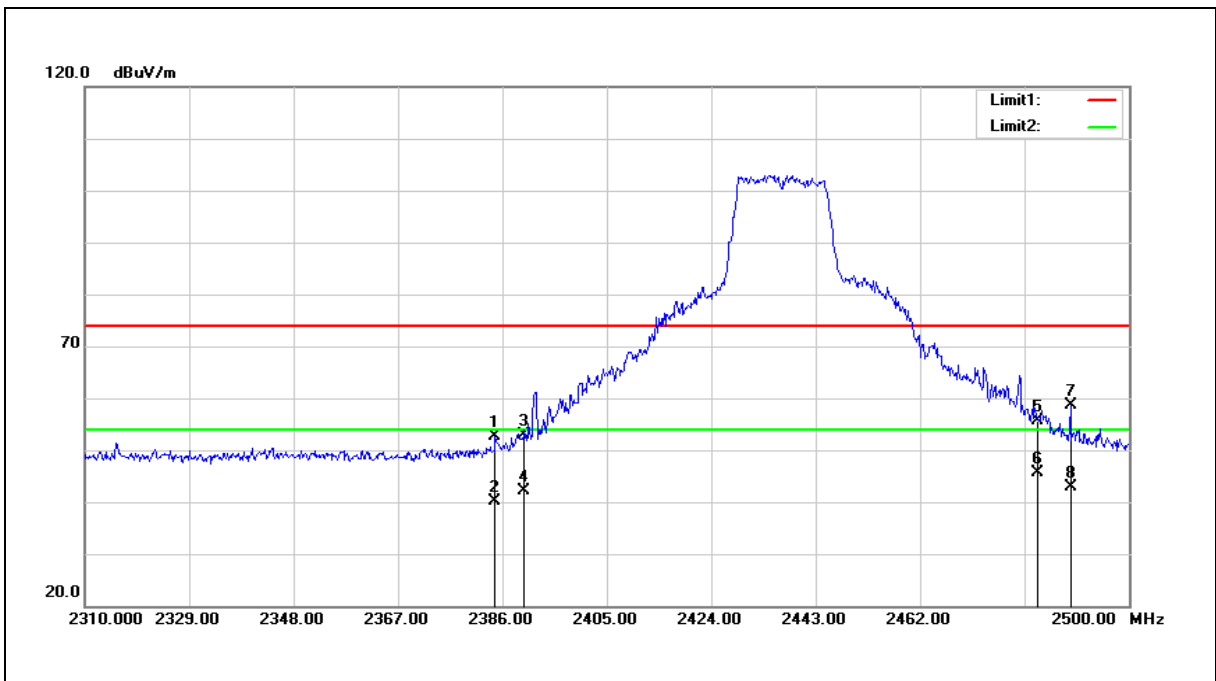

No.	Frequency (MHz)	Reading (dBuV)	Correct Factor (dB/m)	Result (dBuV/m)	Limit (dBuV/m)	Margin (dB)	Remark
1	2384.670	62.28	-9.65	52.63	74.00	-21.37	peak
2	2384.670	49.82	-9.65	40.17	54.00	-13.83	AVG
3	2390.000	62.58	-9.62	52.96	74.00	-21.04	peak
4	2390.000	51.71	-9.62	42.09	54.00	-11.91	AVG
5	2483.500	64.94	-9.37	55.57	74.00	-18.43	peak
6	2483.500	55.03	-9.37	45.66	54.00	-8.34	AVG
7	2489.360	67.94	-9.35	58.59	74.00	-15.41	peak
8	2489.360	52.32	-9.35	42.97	54.00	-11.03	AVG

Note:1.Result (dBuV/m) = Correct Factor (dB/m) + Reading(dBuV).

2.Correction factor (dB/m) = Antenna Factor (dB/m) + Cable loss (dB) – Pre-Amplifier gain (dB).

3.When the peak results are less than average limit, so not need to evaluate the average.



Standard:	FCC Part 15.247	Test Distance:	3 m
Test item:	Band edge	Power:	DC 3.3 V
Frequency:	2462 MHz	Temp.(°C)/Hum.(%RH):	26(°C)/60 %RH
Mode:	Mode 3		
Ant.Polar.:	Horizontal		

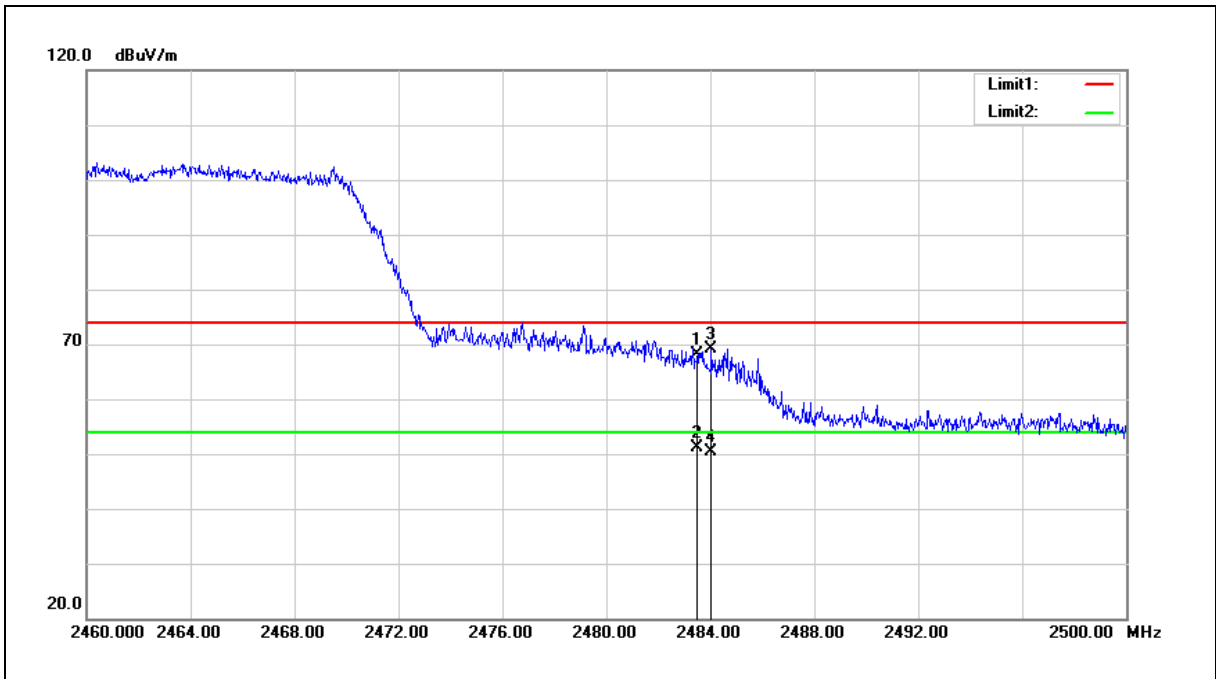

No.	Frequency (MHz)	Reading (dBuV)	Correct Factor (dB/m)	Result (dBuV/m)	Limit (dBuV/m)	Margin (dB)	Remark
1	2483.500	64.48	3.75	68.23	74.00	-5.77	peak
2	2483.500	47.35	3.75	51.10	54.00	-2.90	AVG
3	2484.040	65.49	3.75	69.24	74.00	-4.76	peak
4	2484.040	46.56	3.75	50.31	54.00	-3.69	AVG

- Note:1.Result (dBuV/m) = Correct Factor (dB/m) + Reading(dBuV).
- 2.Correction factor (dB/m) = Antenna Factor (dB/m) + Cable loss (dB) – Pre-Amplifier gain (dB).
- 3.When the peak results are less than average limit, so not need to evaluate the average.



Standard:	FCC Part 15.247	Test Distance:	3 m
Test item:	Band edge	Power:	DC 3.3 V
Frequency:	2462 MHz	Temp.(°C)/Hum.(%RH):	26(°C)/60 %RH
Mode:	Mode 3		
Ant.Polar.:	Vertical		

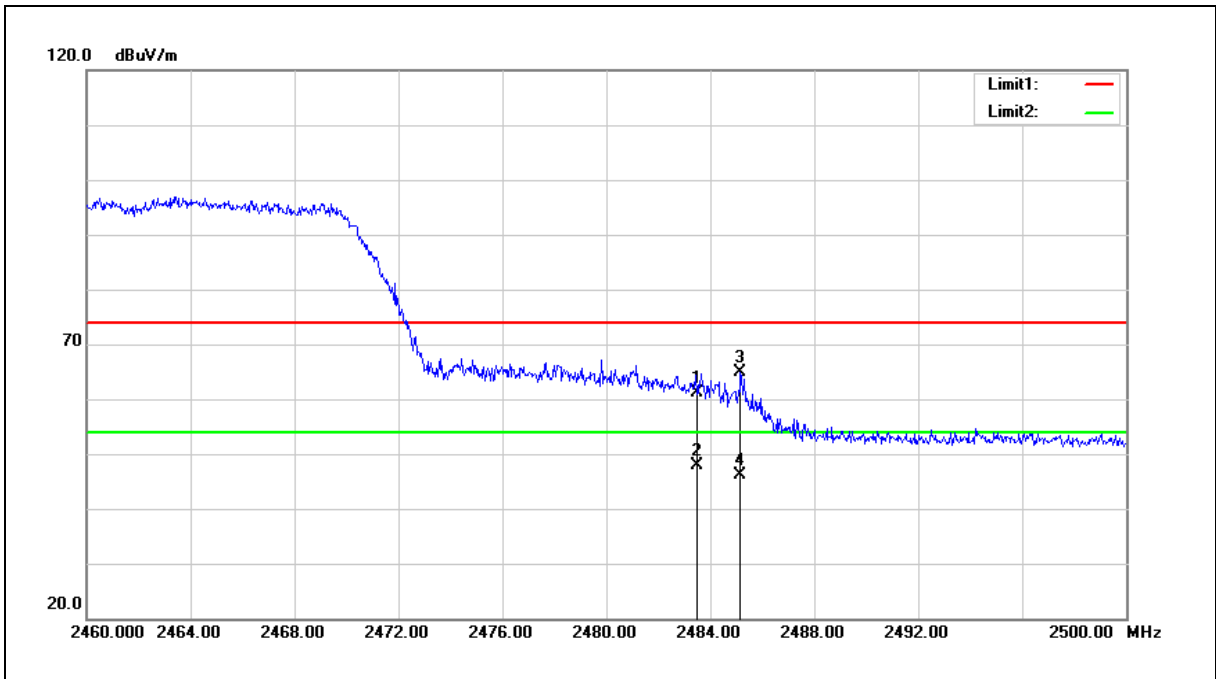

No.	Frequency (MHz)	Reading (dBuV)	Correct Factor (dB/m)	Result (dBuV/m)	Limit (dBuV/m)	Margin (dB)	Remark
1	2483.500	57.37	3.75	61.12	74.00	-12.88	peak
2	2483.500	44.20	3.75	47.95	54.00	-6.05	AVG
3	2485.160	61.04	3.76	64.80	74.00	-9.20	peak
4	2485.160	42.26	3.76	46.02	54.00	-7.98	AVG

- Note:1.Result (dBuV/m) = Correct Factor (dB/m) + Reading(dBuV).
- 2.Correction factor (dB/m) = Antenna Factor (dB/m) + Cable loss (dB) – Pre-Amplifier gain (dB).
- 3.When the peak results are less than average limit, so not need to evaluate the average.



Standard:	FCC Part 15.247	Test Distance:	3 m
Test item:	Band edge	Power:	DC 3.3 V
Frequency:	2412 MHz	Temp.(°C)/Hum.(%RH):	26(°C)/60 %RH
Mode:	Mode 4		
Ant.Polar.:	Horizontal		

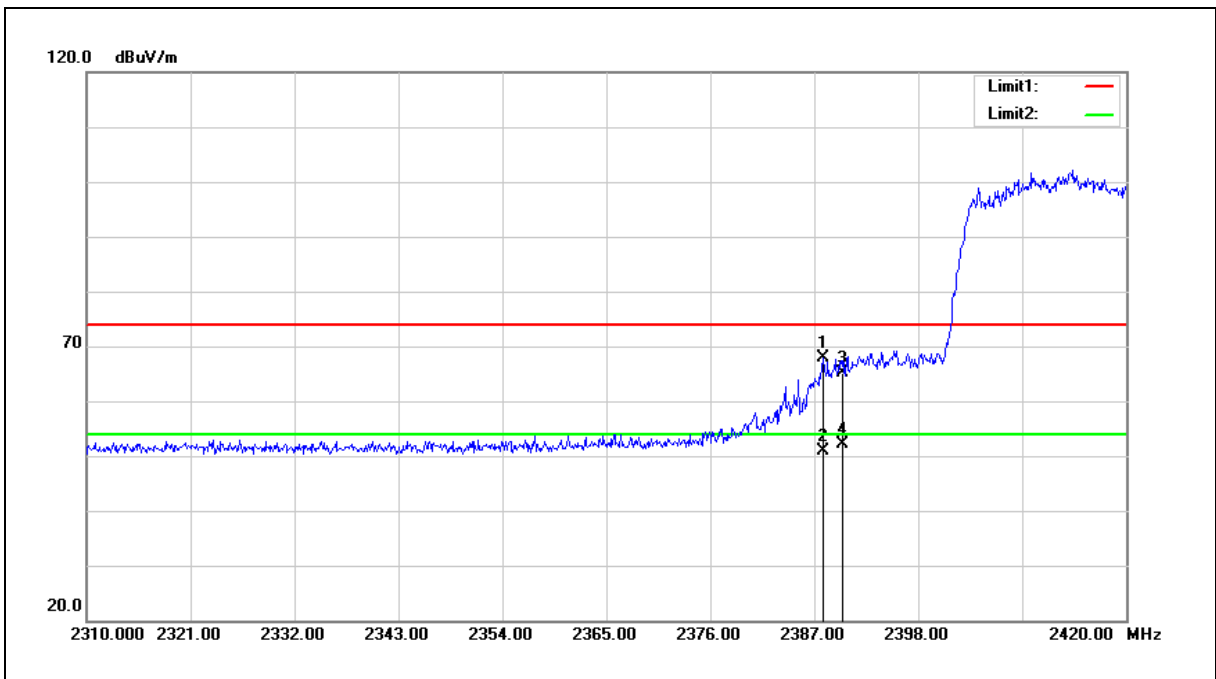

No.	Frequency (MHz)	Reading (dBuV)	Correct Factor (dB/m)	Result (dBuV/m)	Limit (dBuV/m)	Margin (dB)	Remark
1	2387.880	64.30	3.52	67.82	74.00	-6.18	peak
2	2387.880	47.27	3.52	50.79	54.00	-3.21	AVG
3	2390.000	61.60	3.53	65.13	74.00	-8.87	peak
4	2390.000	48.53	3.53	52.06	54.00	-1.94	AVG

- Note:1.Result (dBuV/m) = Correct Factor (dB/m) + Reading(dBuV).
- 2.Correction factor (dB/m) = Antenna Factor (dB/m) + Cable loss (dB) – Pre-Amplifier gain (dB).
- 3.When the peak results are less than average limit, so not need to evaluate the average.



Standard:	FCC Part 15.247	Test Distance:	3 m
Test item:	Band edge	Power:	DC 3.3 V
Frequency:	2412 MHz	Temp.(°C)/Hum.(%RH):	26(°C)/60 %RH
Mode:	Mode 4		
Ant.Polar.:	Vertical		

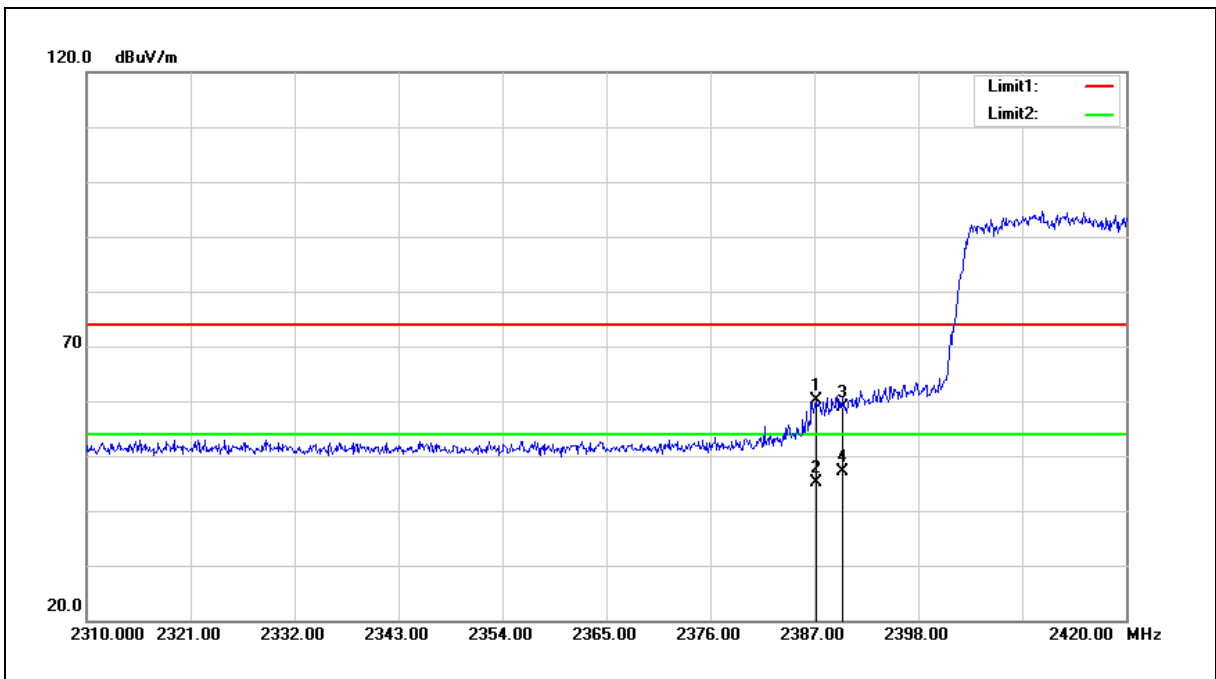

No.	Frequency (MHz)	Reading (dBuV)	Correct Factor (dB/m)	Result (dBuV/m)	Limit (dBuV/m)	Margin (dB)	Remark
1	2387.220	56.56	3.52	60.08	74.00	-13.92	peak
2	2387.220	41.69	3.52	45.21	54.00	-8.79	AVG
3	2390.000	55.35	3.53	58.88	74.00	-15.12	peak
4	2390.000	43.67	3.53	47.20	54.00	-6.80	AVG

Note:1.Result (dBuV/m) = Correct Factor (dB/m) + Reading(dBuV).

2.Correction factor (dB/m) = Antenna Factor (dB/m) + Cable loss (dB) – Pre-Amplifier gain (dB).

3.When the peak results are less than average limit, so not need to evaluate the average.



Standard:	FCC Part 15.247	Test Distance:	3 m
Test item:	Band edge	Power:	DC 3.3 V
Frequency:	2437 MHz	Temp.(°C)/Hum.(%RH):	26(°C)/60 %RH
Mode:	Mode 4		
Ant.Polar.:	Horizontal		

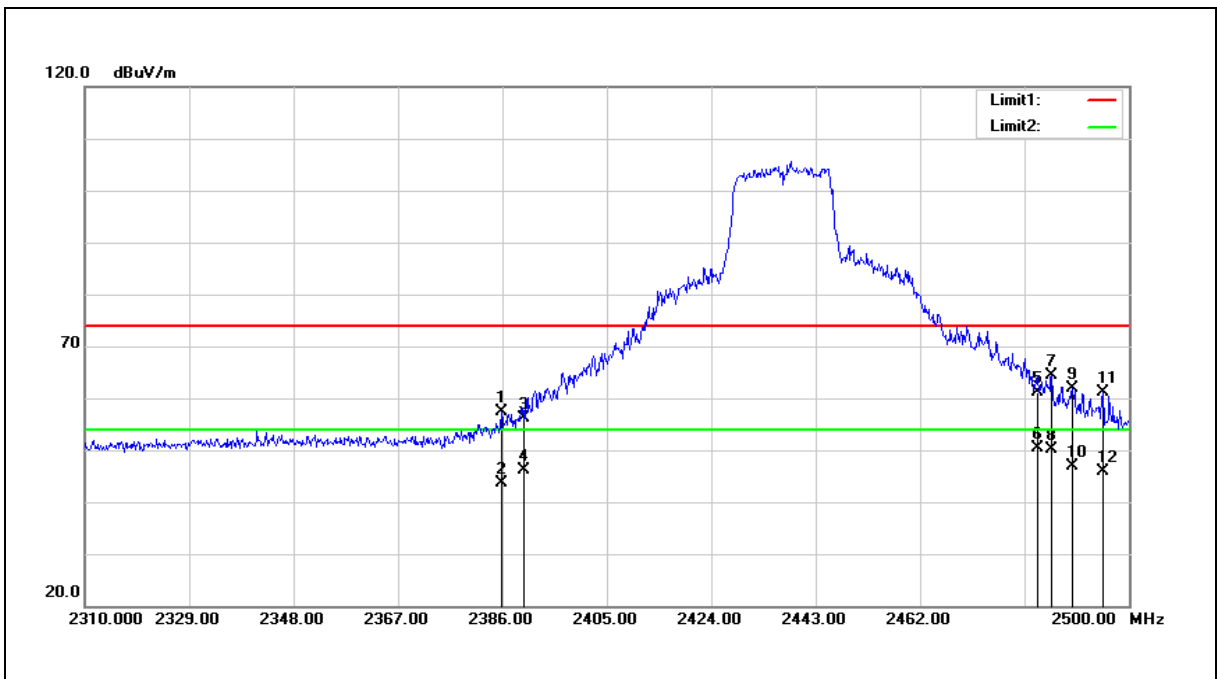



Standard:	FCC Part 15.247	Test Distance:	3 m
Test item:	Band edge	Power:	DC 3.3 V
Frequency:	2437 MHz	Temp.(°C)/Hum.(%RH):	26(°C)/60 %RH
Mode:	Mode 4		
Ant.Polar.:	Horizontal		

No.	Frequency (MHz)	Reading (dBuV)	Correct Factor (dB/m)	Result (dBuV/m)	Limit (dBuV/m)	Margin (dB)	Remark
1	2385.810	67.02	-9.64	57.38	74.00	-16.62	peak
2	2385.810	53.22	-9.64	43.58	54.00	-10.42	AVG
3	2390.000	65.73	-9.62	56.11	74.00	-17.89	peak
4	2390.000	55.68	-9.62	46.06	54.00	-7.94	AVG
5	2483.500	70.60	-9.37	61.23	74.00	-12.77	peak
6	2483.500	59.87	-9.37	50.50	54.00	-3.50	AVG
7	2485.940	73.72	-9.37	64.35	74.00	-9.65	peak
8	2485.940	59.59	-9.37	50.22	54.00	-3.78	AVG
9	2489.740	71.11	-9.35	61.76	74.00	-12.24	peak
10	2489.740	56.32	-9.35	46.97	54.00	-7.03	AVG
11	2495.250	70.53	-9.35	61.18	74.00	-12.82	peak
12	2495.250	55.24	-9.35	45.89	54.00	-8.11	AVG

Note:1.Result (dBuV/m) = Correct Factor (dB/m) + Reading(dBuV).

2.Correction factor (dB/m) = Antenna Factor (dB/m) + Cable loss (dB) – Pre-Amplifier gain (dB).

3.When the peak results are less than average limit, so not need to evaluate the average.



Standard:	FCC Part 15.247	Test Distance:	3 m
Test item:	Band edge	Power:	DC 3.3 V
Frequency:	2437 MHz	Temp.(°C)/Hum.(%RH):	26(°C)/60 %RH
Mode:	Mode 4		
Ant.Polar.:	Vertical		

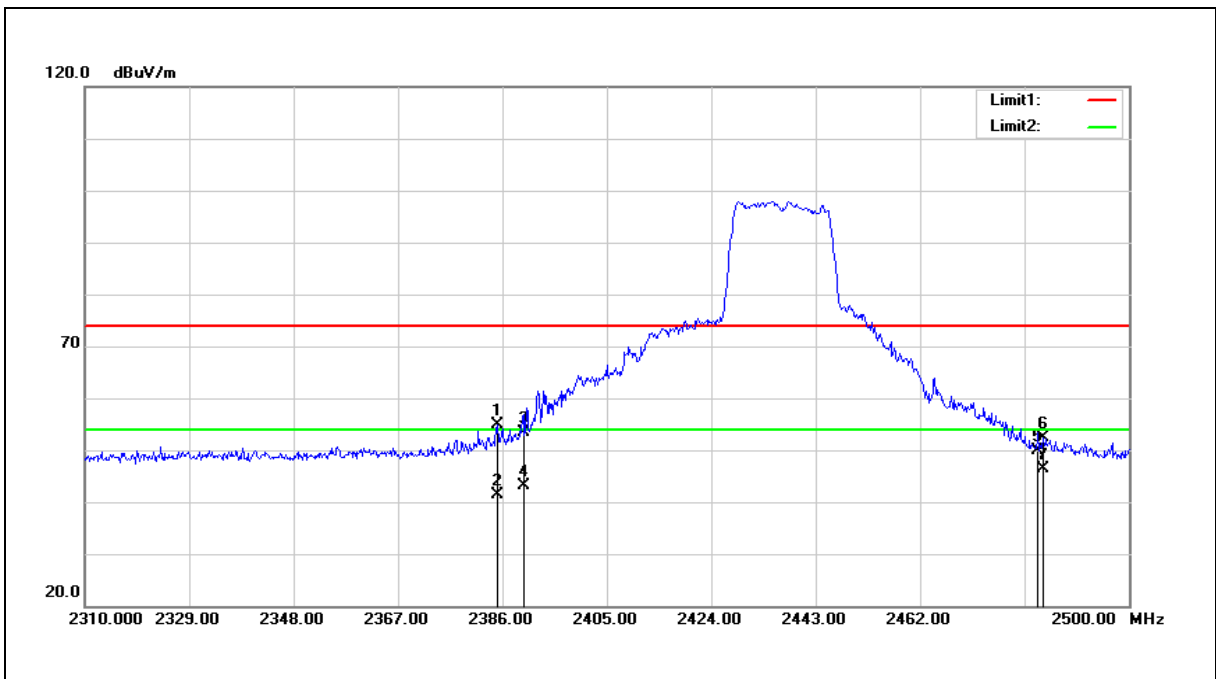

No.	Frequency (MHz)	Reading (dBuV)	Correct Factor (dB/m)	Result (dBuV/m)	Limit (dBuV/m)	Margin (dB)	Remark
1	2385.050	64.64	-9.65	54.99	74.00	-19.01	peak
2	2385.050	51.13	-9.65	41.48	54.00	-12.52	AVG
3	2390.000	63.09	-9.62	53.47	74.00	-20.53	peak
4	2390.000	52.67	-9.62	43.05	54.00	-10.95	AVG
5	2483.500	59.35	-9.37	49.98	74.00	-24.02	peak
6	2484.420	61.73	-9.37	52.36	74.00	-21.64	peak
7	2484.420	55.77	-9.37	46.40	54.00	-7.60	AVG

Note:1.Result (dBuV/m) = Correct Factor (dB/m) + Reading(dBuV).

2.Correction factor (dB/m) = Antenna Factor (dB/m) + Cable loss (dB) – Pre-Amplifier gain (dB).

3.When the peak results are less than average limit, so not need to evaluate the average.



Standard:	FCC Part 15.247	Test Distance:	3 m
Test item:	Band edge	Power:	DC 3.3 V
Frequency:	2462 MHz	Temp.(°C)/Hum.(%RH):	26(°C)/60 %RH
Mode:	Mode 4		
Ant.Polar.:	Horizontal		

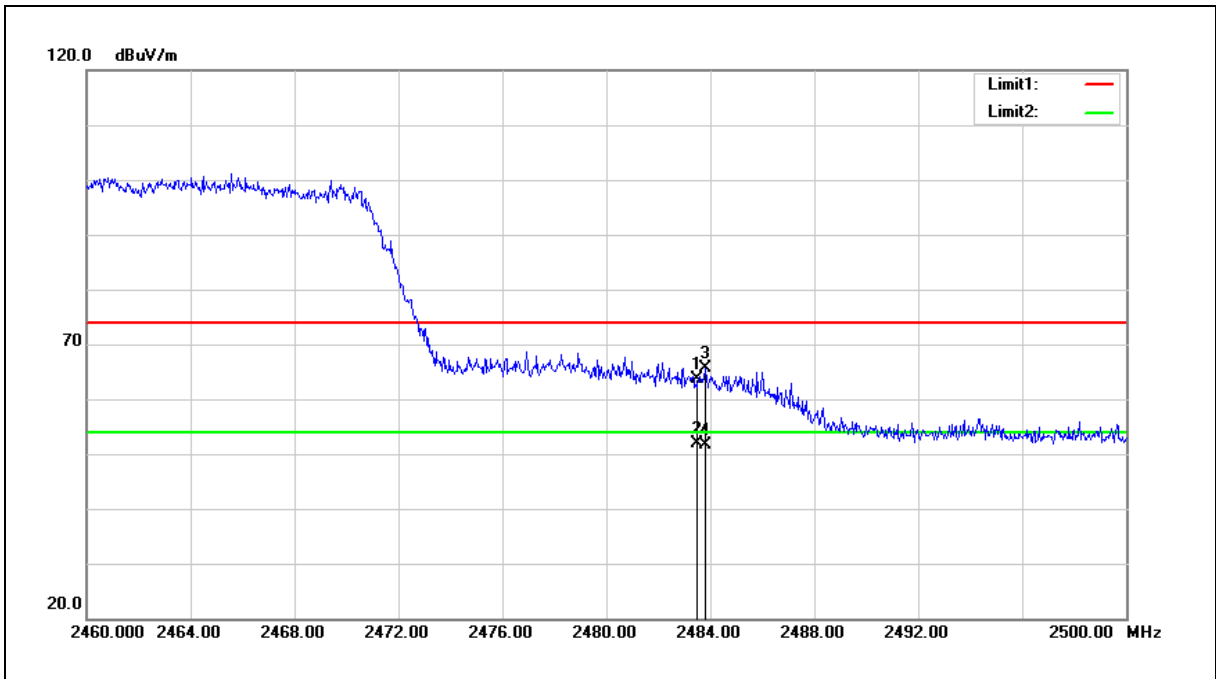

No.	Frequency (MHz)	Reading (dBuV)	Correct Factor (dB/m)	Result (dBuV/m)	Limit (dBuV/m)	Margin (dB)	Remark
1	2483.500	59.99	3.75	63.74	74.00	-10.26	peak
2	2483.500	48.15	3.75	51.90	54.00	-2.10	AVG
3	2483.800	61.95	3.75	65.70	74.00	-8.30	peak
4	2483.800	47.88	3.75	51.63	54.00	-2.37	AVG

- Note:1.Result (dBuV/m) = Correct Factor (dB/m) + Reading(dBuV).
 2.Correction factor (dB/m) = Antenna Factor (dB/m) + Cable loss (dB) – Pre-Amplifier gain (dB).
 3.When the peak results are less than average limit, so not need to evaluate the average.



Standard:	FCC Part 15.247	Test Distance:	3 m
Test item:	Band edge	Power:	DC 3.3 V
Frequency:	2462 MHz	Temp.(°C)/Hum.(%RH):	26(°C)/60 %RH
Mode:	Mode 4		
Ant.Polar.:	Vertical		

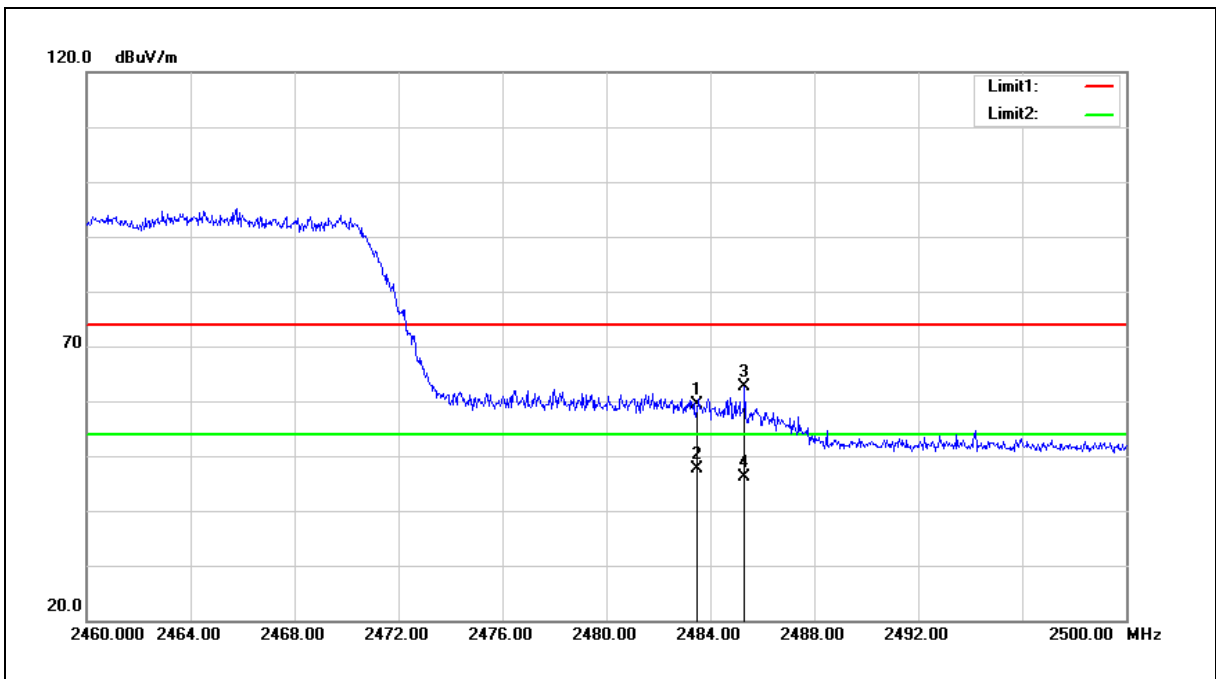

No.	Frequency (MHz)	Reading (dBuV)	Correct Factor (dB/m)	Result (dBuV/m)	Limit (dBuV/m)	Margin (dB)	Remark
1	2483.500	55.70	3.75	59.45	74.00	-14.55	peak
2	2483.500	43.93	3.75	47.68	54.00	-6.32	AVG
3	2485.320	58.88	3.76	62.64	74.00	-11.36	peak
4	2485.320	42.45	3.76	46.21	54.00	-7.79	AVG

Note:1.Result (dBuV/m) = Correct Factor (dB/m) + Reading(dBuV).

2.Correction factor (dB/m) = Antenna Factor (dB/m) + Cable loss (dB) – Pre-Amplifier gain (dB).

3.When the peak results are less than average limit, so not need to evaluate the average.



Standard:	FCC Part 15.247	Test Distance:	3 m
Test item:	Band edge	Power:	DC 3.3 V
Frequency:	2422MHz	Temp.(°C)/Hum.(%RH):	26(°C)/60 %RH
Mode:	Mode 5		
Ant.Polar.:	Horizontal		

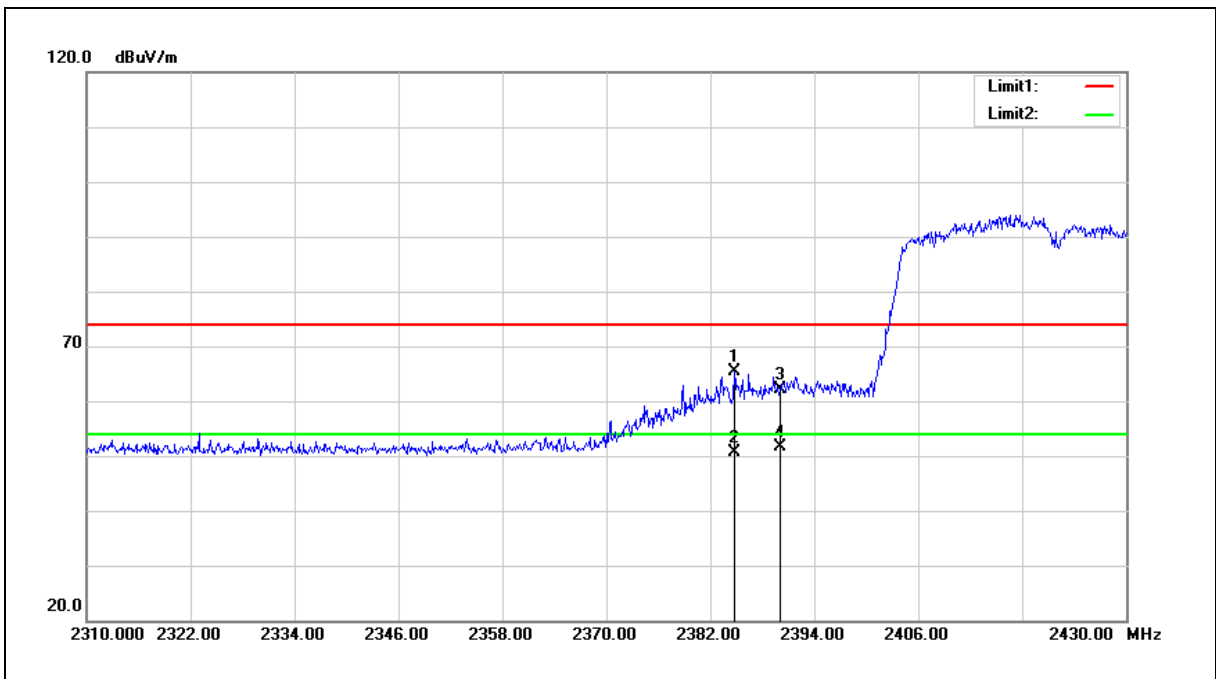

No.	Frequency (MHz)	Reading (dBuV)	Correct Factor (dB/m)	Result (dBuV/m)	Limit (dBuV/m)	Margin (dB)	Remark
1	2384.760	61.92	3.52	65.44	74.00	-8.56	peak
2	2384.760	47.16	3.52	50.68	54.00	-3.32	AVG
3	2390.000	58.65	3.53	62.18	74.00	-11.82	peak
4	2390.000	48.01	3.53	51.54	54.00	-2.46	AVG

Note:1.Result (dBuV/m) = Correct Factor (dB/m) + Reading(dBuV).

2.Correction factor (dB/m) = Antenna Factor (dB/m) + Cable loss (dB) – Pre-Amplifier gain (dB).

3.When the peak results are less than average limit, so not need to evaluate the average.



Standard:	FCC Part 15.247	Test Distance:	3 m
Test item:	Band edge	Power:	DC 3.3 V
Frequency:	2422 MHz	Temp.(°C)/Hum.(%RH):	26(°C)/60 %RH
Mode:	Mode 5		
Ant.Polar.:	Vertical		

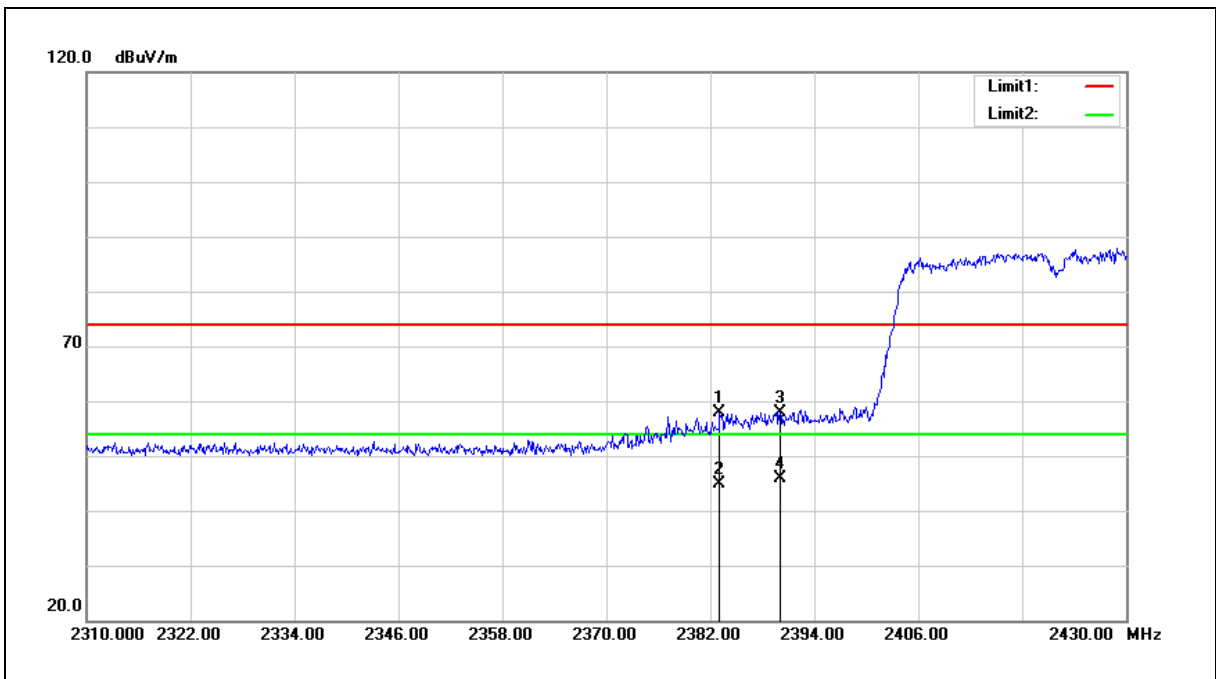

No.	Frequency (MHz)	Reading (dBuV)	Correct Factor (dB/m)	Result (dBuV/m)	Limit (dBuV/m)	Margin (dB)	Remark
1	2383.080	54.49	3.51	58.00	74.00	-16.00	peak
2	2383.080	41.30	3.51	44.81	54.00	-9.19	AVG
3	2390.000	54.37	3.53	57.90	74.00	-16.10	peak
4	2390.000	42.42	3.53	45.95	54.00	-8.05	AVG

- Note:1.Result (dBuV/m) = Correct Factor (dB/m) + Reading(dBuV).
- 2.Correction factor (dB/m) = Antenna Factor (dB/m) + Cable loss (dB) – Pre-Amplifier gain (dB).
- 3.When the peak results are less than average limit, so not need to evaluate the average.



Standard:	FCC Part 15.247	Test Distance:	3 m
Test item:	Band edge	Power:	DC 3.3 V
Frequency:	2437 MHz	Temp.(°C)/Hum.(%RH):	26(°C)/60 %RH
Mode:	Mode 5		
Ant.Polar.:	Horizontal		

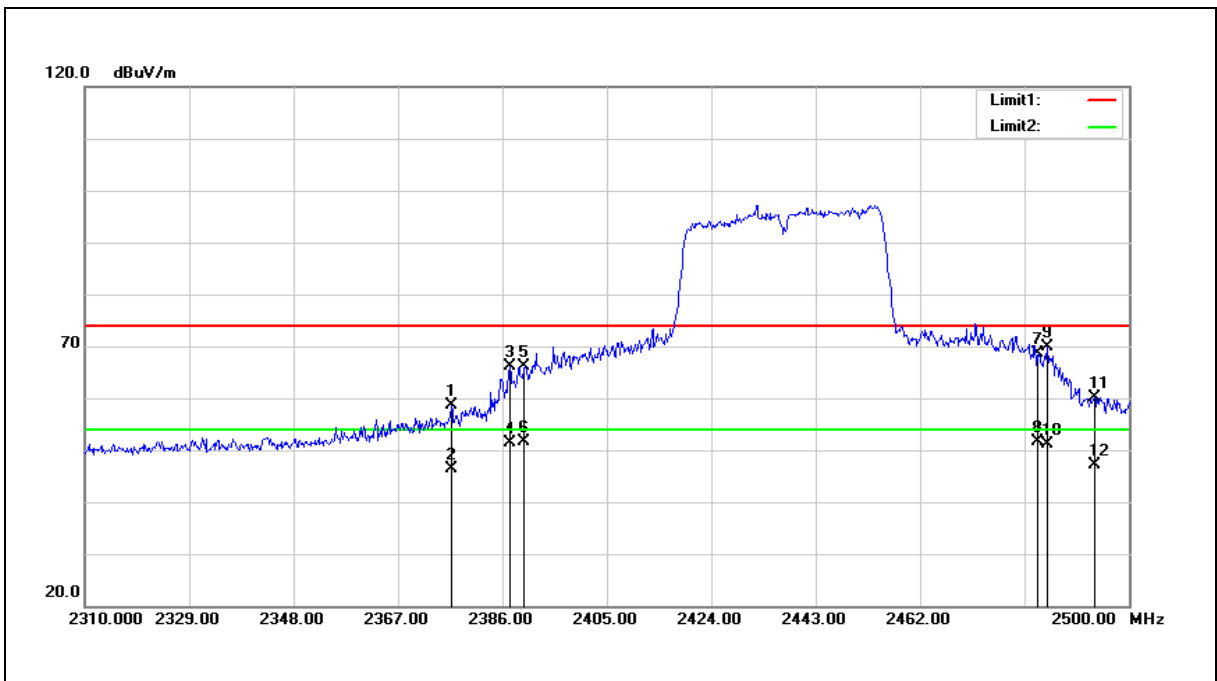



Standard:	FCC Part 15.247	Test Distance:	3 m
Test item:	Band edge	Power:	DC 3.3 V
Frequency:	2437 MHz	Temp.(°C)/Hum.(%RH):	26(°C)/60 %RH
Mode:	Mode 5		
Ant.Polar.:	Horizontal		

No.	Frequency (MHz)	Reading (dBuV)	Correct Factor (dB/m)	Result (dBuV/m)	Limit (dBuV/m)	Margin (dB)	Remark
1	2376.690	68.21	-9.68	58.53	74.00	-15.47	peak
2	2376.690	56.08	-9.68	46.40	54.00	-7.60	AVG
3	2387.330	75.66	-9.64	66.02	74.00	-7.98	peak
4	2387.330	61.07	-9.64	51.43	54.00	-2.57	AVG
5	2390.000	75.74	-9.62	66.12	74.00	-7.88	peak
6	2390.000	61.33	-9.62	51.71	54.00	-2.29	AVG
7	2483.500	78.08	-9.37	68.71	74.00	-5.29	peak
8	2483.500	60.96	-9.37	51.59	54.00	-2.41	AVG
9	2485.180	79.22	-9.37	69.85	74.00	-4.15	peak
10	2485.180	60.60	-9.37	51.23	54.00	-2.77	AVG
11	2493.730	69.52	-9.35	60.17	74.00	-13.83	peak
12	2493.730	56.50	-9.35	47.15	54.00	-6.85	AVG

Note:1.Result (dBuV/m) = Correct Factor (dB/m) + Reading(dBuV).

2.Correction factor (dB/m) = Antenna Factor (dB/m) + Cable loss (dB) – Pre-Amplifier gain (dB).

3.When the peak results are less than average limit, so not need to evaluate the average.



Standard:	FCC Part 15.247	Test Distance:	3 m
Test item:	Band edge	Power:	DC 3.3 V
Frequency:	2437 MHz	Temp.(°C)/Hum.(%RH):	26(°C)/60 %RH
Mode:	Mode 5		
Ant.Polar.:	Vertical		

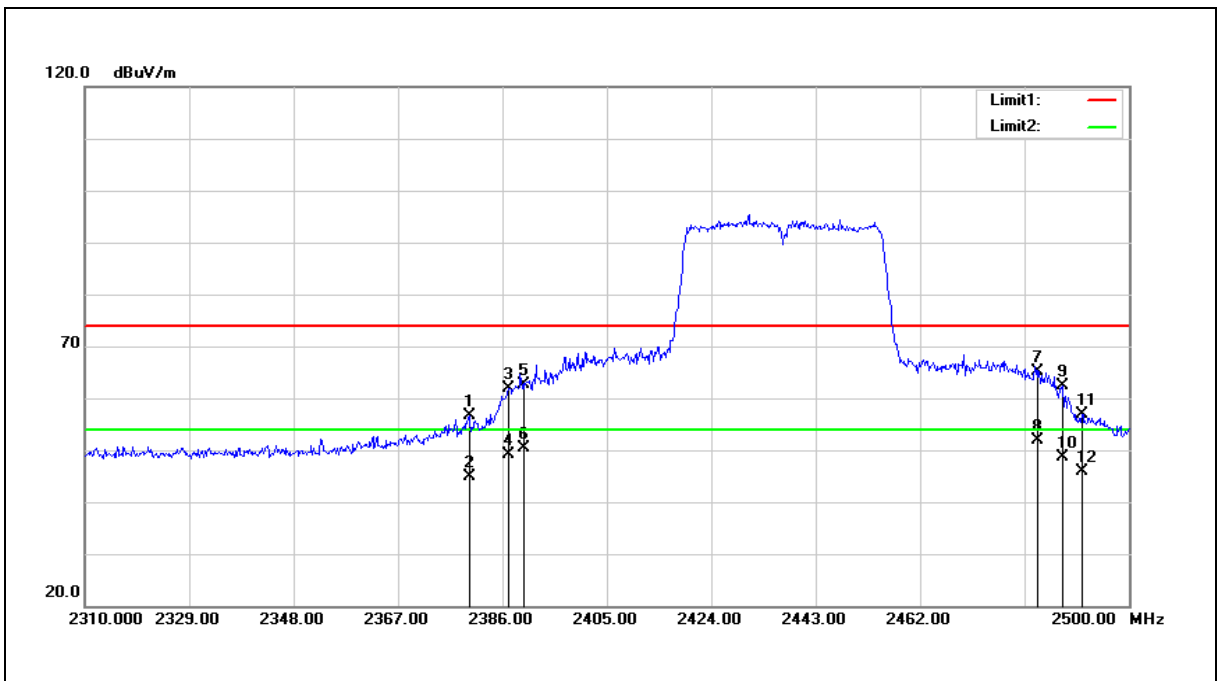



Standard:	FCC Part 15.247	Test Distance:	3 m
Test item:	Band edge	Power:	DC 3.3 V
Frequency:	2437 MHz	Temp.(°C)/Hum.(%RH):	26(°C)/60 %RH
Mode:	Mode 5		
Ant.Polar.:	Vertical		

No.	Frequency (MHz)	Reading (dBuV)	Correct Factor (dB/m)	Result (dBuV/m)	Limit (dBuV/m)	Margin (dB)	Remark
1	2379.920	66.35	-9.66	56.69	74.00	-17.31	peak
2	2379.920	54.56	-9.66	44.90	54.00	-9.10	AVG
3	2387.140	71.51	-9.64	61.87	74.00	-12.13	peak
4	2387.140	58.81	-9.64	49.17	54.00	-4.83	AVG
5	2390.000	72.32	-9.62	62.70	74.00	-11.30	peak
6	2390.000	60.10	-9.62	50.48	54.00	-3.52	AVG
7	2483.500	74.42	-9.37	65.05	74.00	-8.95	peak
8	2483.500	61.23	-9.37	51.86	54.00	-2.14	AVG
9	2487.840	71.64	-9.36	62.28	74.00	-11.72	peak
10	2487.840	57.93	-9.36	48.57	54.00	-5.43	AVG
11	2491.450	66.31	-9.35	56.96	74.00	-17.04	peak
12	2491.450	55.30	-9.35	45.95	54.00	-8.05	AVG

Note:1.Result (dBuV/m) = Correct Factor (dB/m) + Reading(dBuV).

2.Correction factor (dB/m) = Antenna Factor (dB/m) + Cable loss (dB) – Pre-Amplifier gain (dB).

3.When the peak results are less than average limit, so not need to evaluate the average.



Standard:	FCC Part 15.247	Test Distance:	3 m
Test item:	Band edge	Power:	DC 3.3 V
Frequency:	2452 MHz	Temp.(°C)/Hum.(%RH):	26(°C)/60 %RH
Mode:	Mode 5		
Ant.Polar.:	Horizontal		

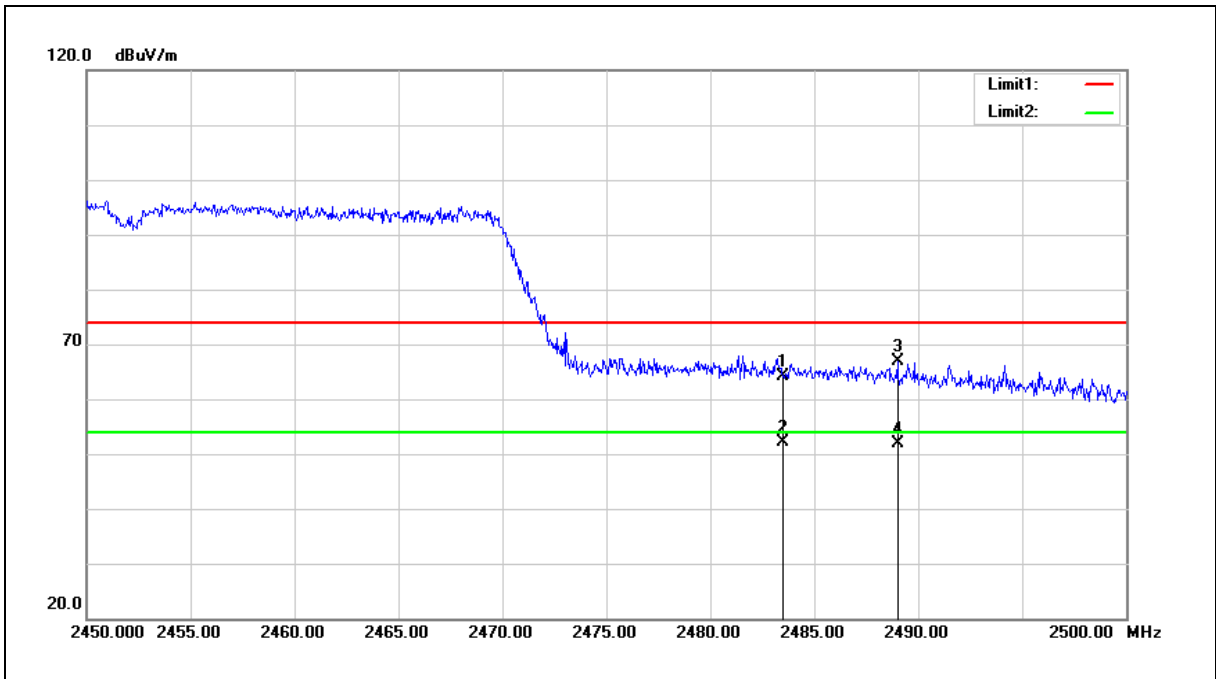

No.	Frequency (MHz)	Reading (dBuV)	Correct Factor (dB/m)	Result (dBuV/m)	Limit (dBuV/m)	Margin (dB)	Remark
1	2483.500	60.42	3.75	64.17	74.00	-9.83	peak
2	2483.500	48.33	3.75	52.08	54.00	-1.92	AVG
3	2489.000	63.10	3.77	66.87	74.00	-7.13	peak
4	2489.000	48.21	3.77	51.98	54.00	-2.02	AVG

- Note:1.Result (dBuV/m) = Correct Factor (dB/m) + Reading(dBuV).
 2.Correction factor (dB/m) = Antenna Factor (dB/m) + Cable loss (dB) – Pre-Amplifier gain (dB).
 3.When the peak results are less than average limit, so not need to evaluate the average.



Standard:	FCC Part 15.247	Test Distance:	3 m
Test item:	Band edge	Power:	DC 3.3 V
Frequency:	2452 MHz	Temp.(°C)/Hum.(%RH):	26(°C)/60 %RH
Mode:	Mode 5		
Ant.Polar.:	Vertical		

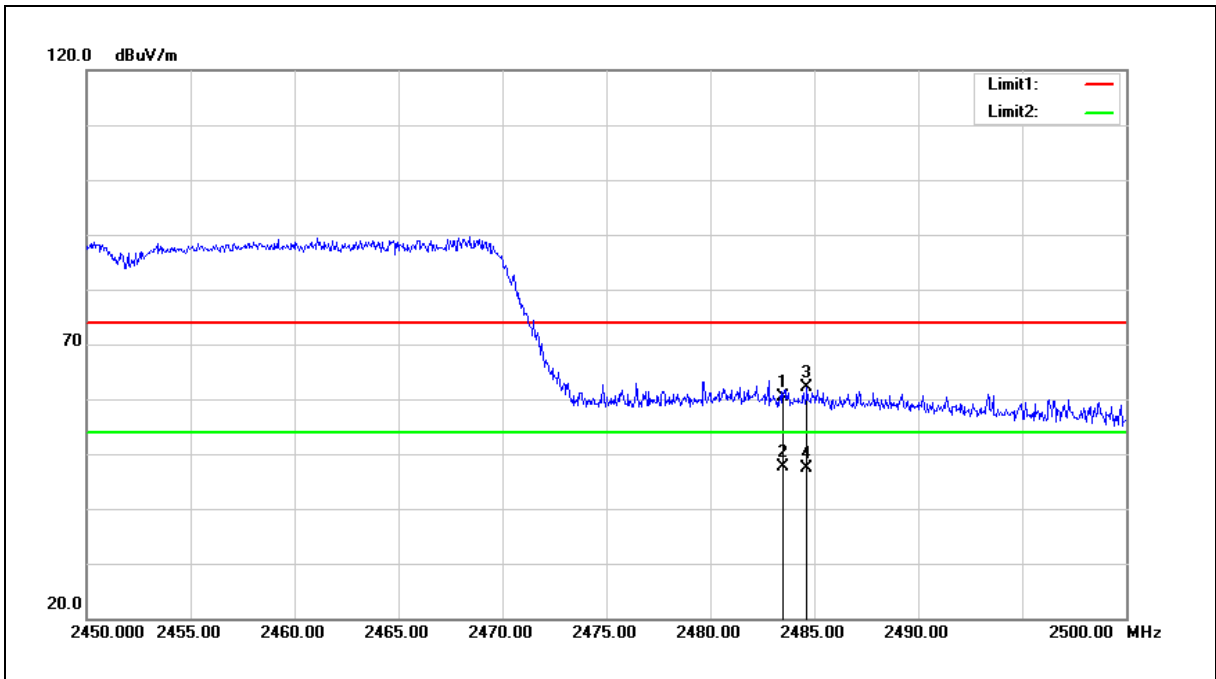

No.	Frequency (MHz)	Reading (dBuV)	Correct Factor (dB/m)	Result (dBuV/m)	Limit (dBuV/m)	Margin (dB)	Remark
1	2483.500	56.56	3.75	60.31	74.00	-13.69	peak
2	2483.500	43.93	3.75	47.68	54.00	-6.32	AVG
3	2484.650	58.44	3.76	62.20	74.00	-11.80	peak
4	2484.650	43.50	3.76	47.26	54.00	-6.74	AVG

- Note:1.Result (dBuV/m) = Correct Factor (dB/m) + Reading(dBuV).
- 2.Correction factor (dB/m) = Antenna Factor (dB/m) + Cable loss (dB) – Pre-Amplifier gain (dB).
- 3.When the peak results are less than average limit, so not need to evaluate the average.



Power setting 2_Antenna Type: Heavy Duty Screw Mount Antenna

Standard:	FCC Part 15.247	Test Distance:	3 m
Test item:	Band edge	Power:	DC 3.3 V
Frequency:	2412 MHz	Temp.(°C)/Hum.(%RH):	26(°C)/60 %RH
Mode:	Mode 2		
Ant.Polar.:	Horizontal		

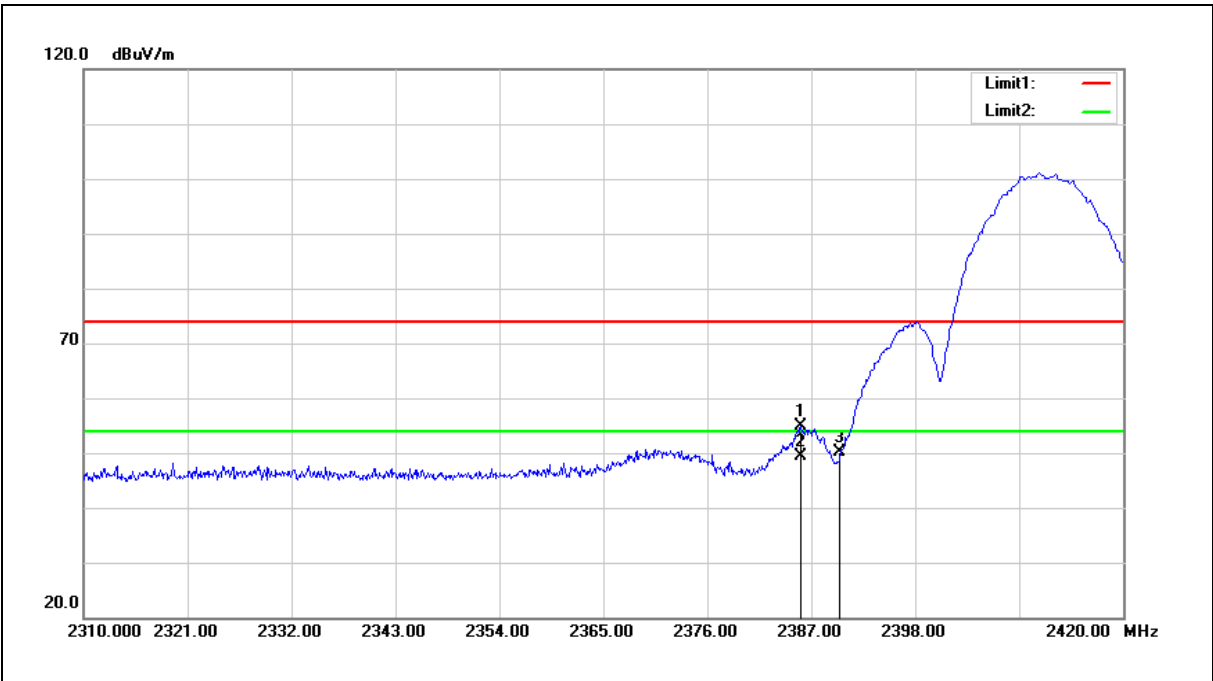

No.	Frequency (MHz)	Reading (dBuV)	Correct Factor (dB/m)	Result (dBuV/m)	Limit (dBuV/m)	Margin (dB)	Remark
1	2385.900	64.49	-9.64	54.85	74.00	-19.15	peak
2	2385.900	59.06	-9.64	49.42	54.00	-4.58	AVG
3	2390.000	59.87	-9.62	50.25	74.00	-23.75	peak

Note:1.Result (dBuV/m) = Correct Factor (dB/m) + Reading(dBuV).

2.Correction factor (dB/m) = Antenna Factor (dB/m) + Cable loss (dB) – Pre-Amplifier gain (dB).

3.When the peak results are less than average limit, so not need to evaluate the average.



Standard:	FCC Part 15.247	Test Distance:	3 m
Test item:	Band edge	Power:	DC 3.3 V
Frequency:	2412 MHz	Temp.(°C)/Hum.(%RH):	26(°C)/60 %RH
Mode:	Mode 2		
Ant.Polar.:	Vertical		

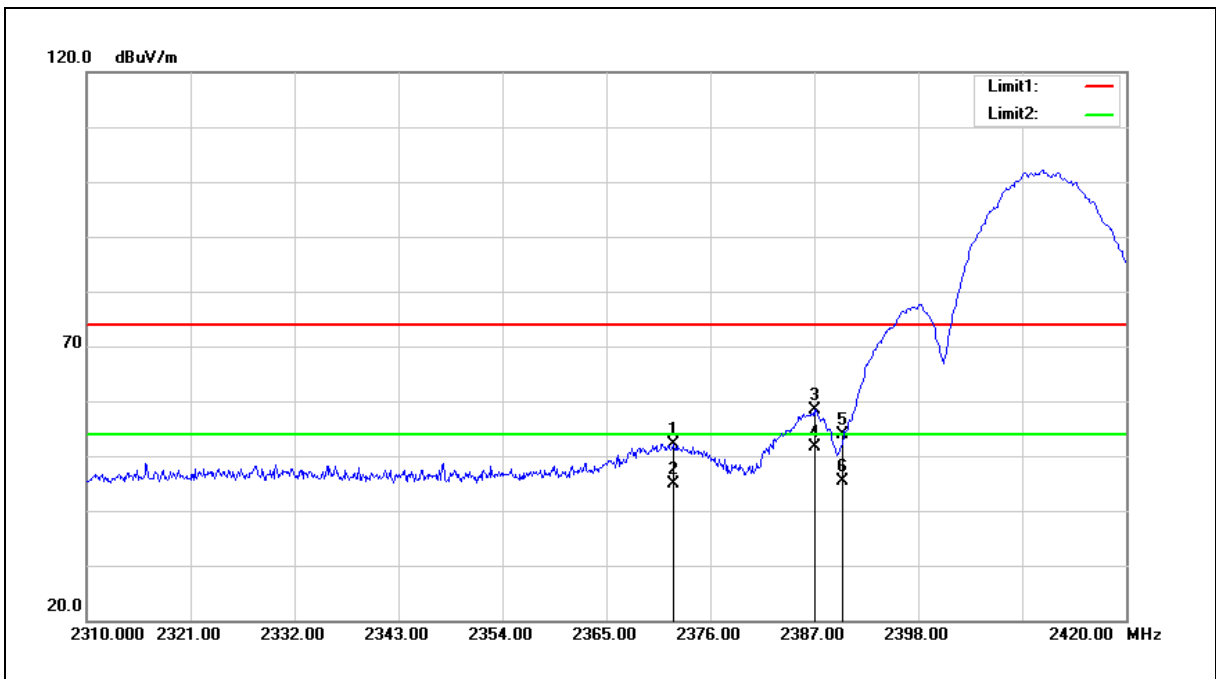

No.	Frequency (MHz)	Reading (dBuV)	Correct Factor (dB/m)	Result (dBuV/m)	Limit (dBuV/m)	Margin (dB)	Remark
1	2372.040	61.84	-9.69	52.15	74.00	-21.85	peak
2	2372.040	54.45	-9.69	44.76	54.00	-9.24	AVG
3	2387.000	68.01	-9.64	58.37	74.00	-15.63	peak
4	2387.000	61.27	-9.64	51.63	54.00	-2.37	AVG
5	2390.000	63.45	-9.62	53.83	74.00	-20.17	peak
6	2390.000	55.11	-9.62	45.49	54.00	-8.51	AVG

Note:1.Result (dBuV/m) = Correct Factor (dB/m) + Reading(dBuV).

2.Correction factor (dB/m) = Antenna Factor (dB/m) + Cable loss (dB) – Pre-Amplifier gain (dB).

3.When the peak results are less than average limit, so not need to evaluate the average.



Standard:	FCC Part 15.247	Test Distance:	3 m
Test item:	Band edge	Power:	DC 3.3 V
Frequency:	2437 MHz	Temp.(°C)/Hum.(%RH):	26(°C)/60 %RH
Mode:	Mode 2		
Ant.Polar.:	Horizontal		

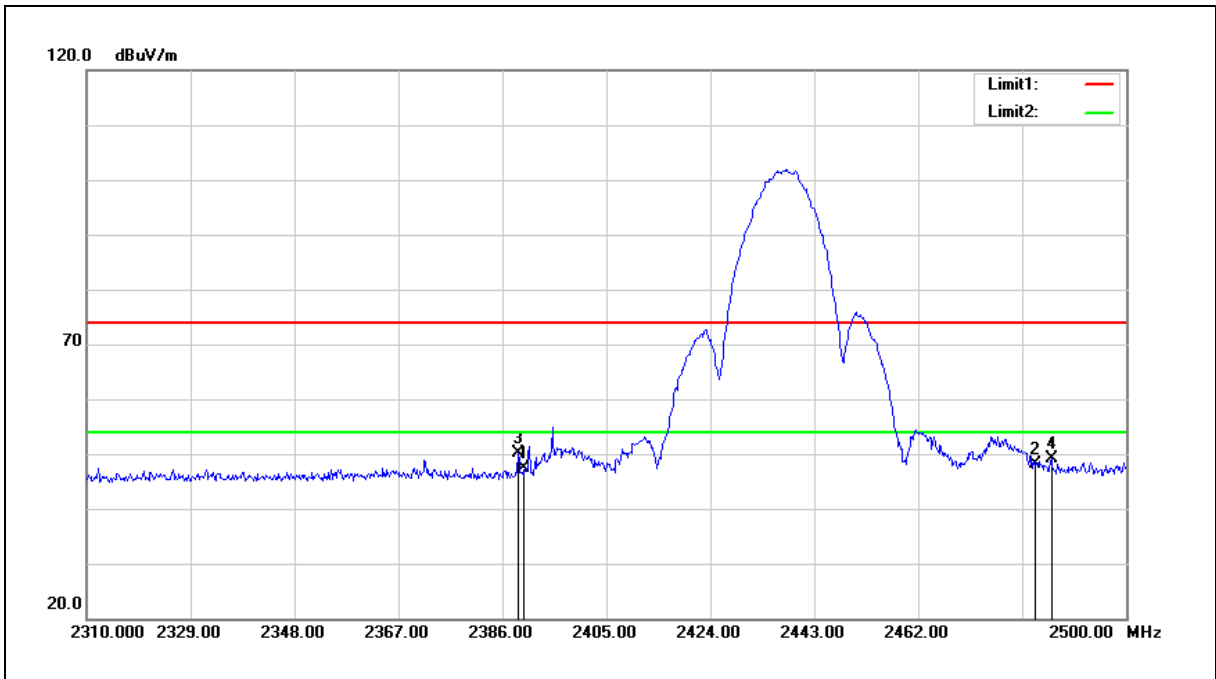

No.	Frequency (MHz)	Reading (dBuV)	Correct Factor (dB/m)	Result (dBuV/m)	Limit (dBuV/m)	Margin (dB)	Remark
1	2390.000	57.07	-9.62	47.45	74.00	-26.55	peak
2	2483.500	57.47	-9.37	48.10	74.00	-25.90	peak
3	2388.850	59.80	-9.63	50.17	74.00	-23.83	peak
4	2486.320	58.38	-9.37	49.01	74.00	-24.99	peak

- Note:1.Result (dBuV/m) = Correct Factor (dB/m) + Reading(dBuV).
 2.Correction factor (dB/m) = Antenna Factor (dB/m) + Cable loss (dB) – Pre-Amplifier gain (dB).
 3.When the peak results are less than average limit, so not need to evaluate the average.



Standard:	FCC Part 15.247	Test Distance:	3 m
Test item:	Band edge	Power:	DC 3.3 V
Frequency:	2437 MHz	Temp.(°C)/Hum.(%RH):	26(°C)/60 %RH
Mode:	Mode 2		
Ant.Polar.:	Vertical		

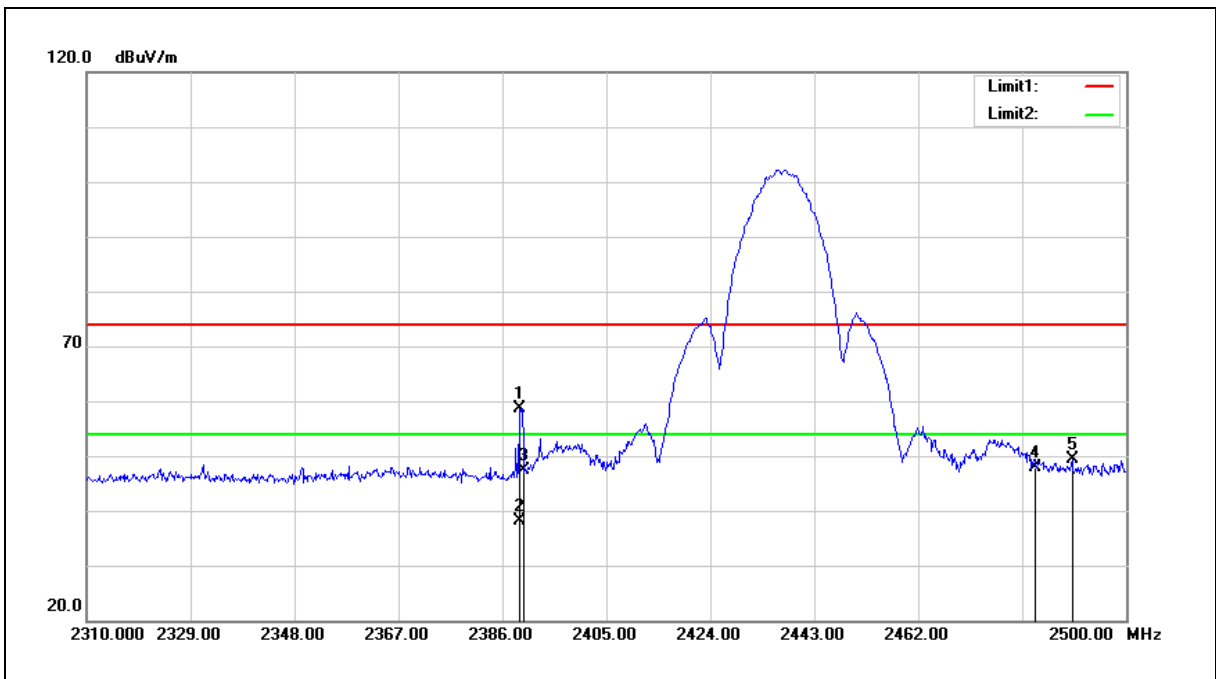

No.	Frequency (MHz)	Reading (dBuV)	Correct Factor (dB/m)	Result (dBuV/m)	Limit (dBuV/m)	Margin (dB)	Remark
1	2389.230	68.32	-9.63	58.69	74.00	-15.31	peak
2	2389.230	47.66	-9.63	38.03	54.00	-15.97	AVG
3	2390.000	56.96	-9.62	47.34	74.00	-26.66	peak
4	2483.500	57.17	-9.37	47.80	74.00	-26.20	peak
5	2490.120	58.72	-9.35	49.37	74.00	-24.63	peak

Note:1.Result (dBuV/m) = Correct Factor (dB/m) + Reading(dBuV).

2.Correction factor (dB/m) = Antenna Factor (dB/m) + Cable loss (dB) – Pre-Amplifier gain (dB).

3.When the peak results are less than average limit, so not need to evaluate the average.



Standard:	FCC Part 15.247	Test Distance:	3 m
Test item:	Band edge	Power:	DC 3.3 V
Frequency:	2462 MHz	Temp.(°C)/Hum.(%RH):	26(°C)/60 %RH
Mode:	Mode 2		
Ant.Polar.:	Horizontal		

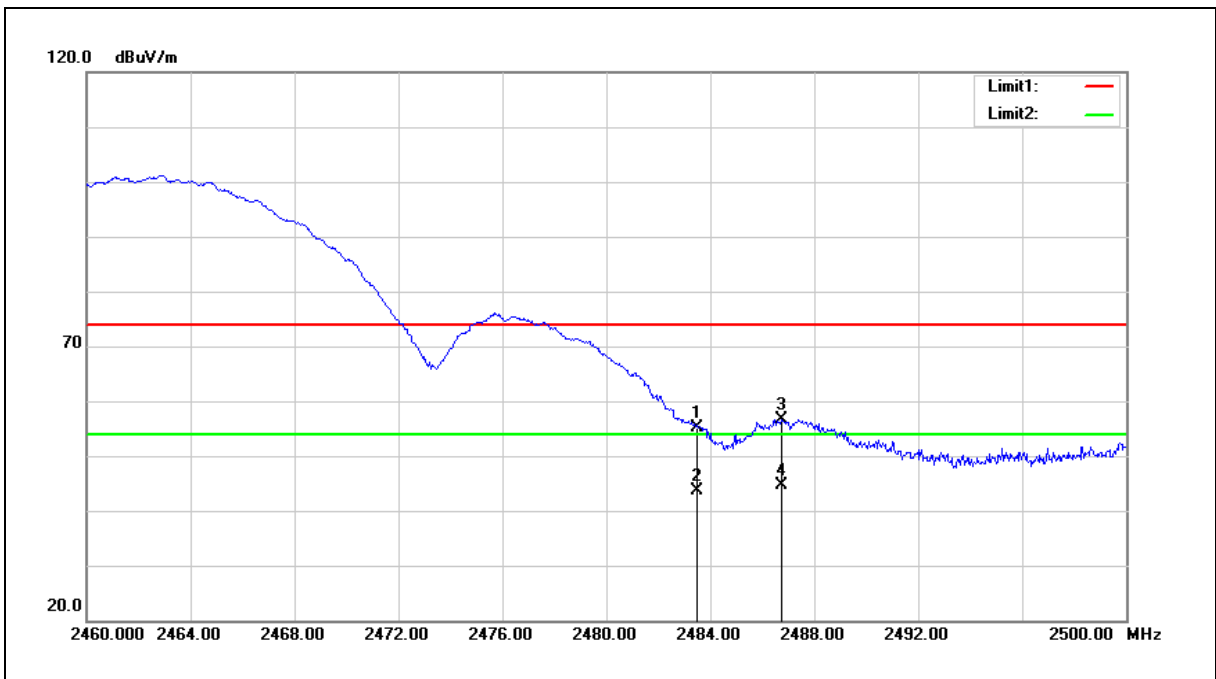

No.	Frequency (MHz)	Reading (dBuV)	Correct Factor (dB/m)	Result (dBuV/m)	Limit (dBuV/m)	Margin (dB)	Remark
1	2483.500	64.47	-9.37	55.10	74.00	-18.90	peak
2	2483.500	52.97	-9.37	43.60	54.00	-10.40	AVG
3	2486.720	65.99	-9.37	56.62	74.00	-17.38	peak
4	2486.720	54.03	-9.37	44.66	54.00	-9.34	AVG

Note:1.Result (dBuV/m) = Correct Factor (dB/m) + Reading(dBuV).

2.Correction factor (dB/m) = Antenna Factor (dB/m) + Cable loss (dB) – Pre-Amplifier gain (dB).

3.When the peak results are less than average limit, so not need to evaluate the average.



Standard:	FCC Part 15.247	Test Distance:	3 m
Test item:	Band edge	Power:	DC 3.3 V
Frequency:	2462 MHz	Temp.(°C)/Hum.(%RH):	26(°C)/60 %RH
Mode:	Mode 2		
Ant.Polar.:	Vertical		

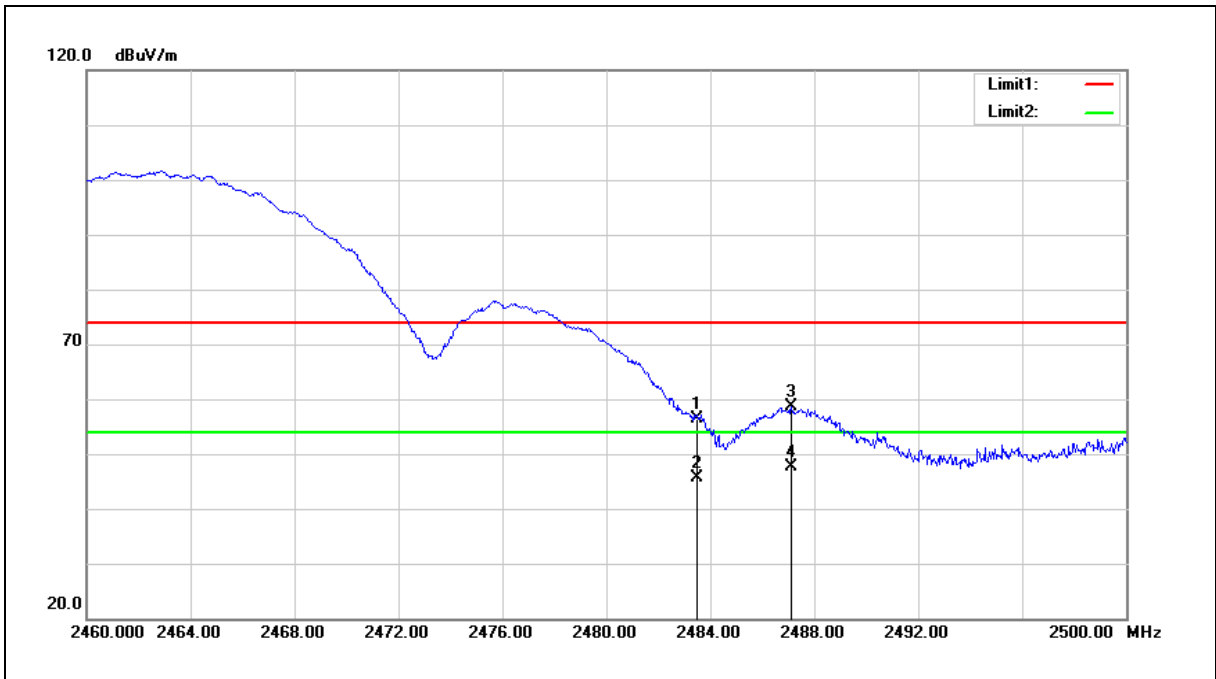

No.	Frequency (MHz)	Reading (dBuV)	Correct Factor (dB/m)	Result (dBuV/m)	Limit (dBuV/m)	Margin (dB)	Remark
1	2483.500	65.73	-9.37	56.36	74.00	-17.64	peak
2	2483.500	54.99	-9.37	45.62	54.00	-8.38	AVG
3	2487.120	67.89	-9.37	58.52	74.00	-15.48	peak
4	2487.120	56.98	-9.37	47.61	54.00	-6.39	AVG

Note:1.Result (dBuV/m) = Correct Factor (dB/m) + Reading(dBuV).

2.Correction factor (dB/m) = Antenna Factor (dB/m) + Cable loss (dB) – Pre-Amplifier gain (dB).

3.When the peak results are less than average limit, so not need to evaluate the average.



Standard:	FCC Part 15.247	Test Distance:	3 m
Test item:	Band edge	Power:	DC 3.3 V
Frequency:	2412 MHz	Temp.(°C)/Hum.(%RH):	26(°C)/60 %RH
Mode:	Mode 3		
Ant.Polar.:	Horizontal		

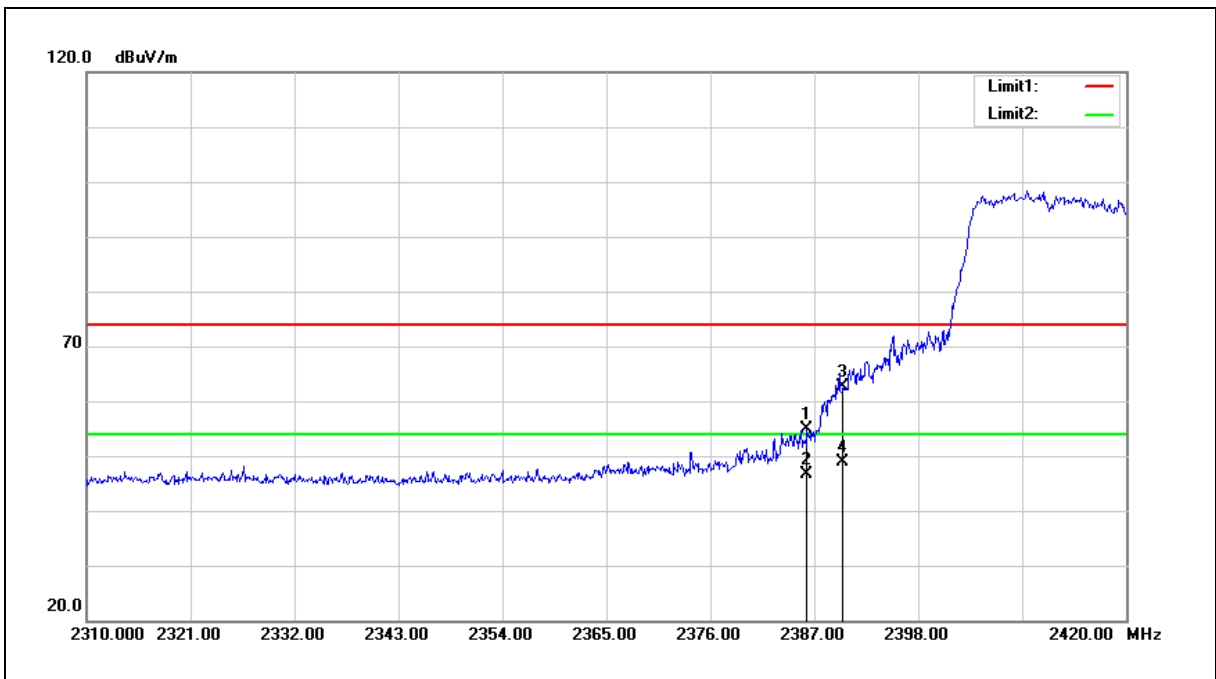

No.	Frequency (MHz)	Reading (dBuV)	Correct Factor (dB/m)	Result (dBuV/m)	Limit (dBuV/m)	Margin (dB)	Remark
1	2386.230	64.61	-9.64	54.97	74.00	-19.03	peak
2	2386.230	56.15	-9.64	46.51	54.00	-7.49	AVG
3	2390.000	72.22	-9.62	62.60	74.00	-11.40	peak
4	2390.000	58.60	-9.62	48.98	54.00	-5.02	AVG

Note:1.Result (dBuV/m) = Correct Factor (dB/m) + Reading(dBuV).

2.Correction factor (dB/m) = Antenna Factor (dB/m) + Cable loss (dB) – Pre-Amplifier gain (dB).

3.When the peak results are less than average limit, so not need to evaluate the average.



Standard:	FCC Part 15.247	Test Distance:	3 m
Test item:	Band edge	Power:	DC 3.3 V
Frequency:	2412 MHz	Temp.(°C)/Hum.(%RH):	26(°C)/60 %RH
Mode:	Mode 3		
Ant.Polar.:	Vertical		

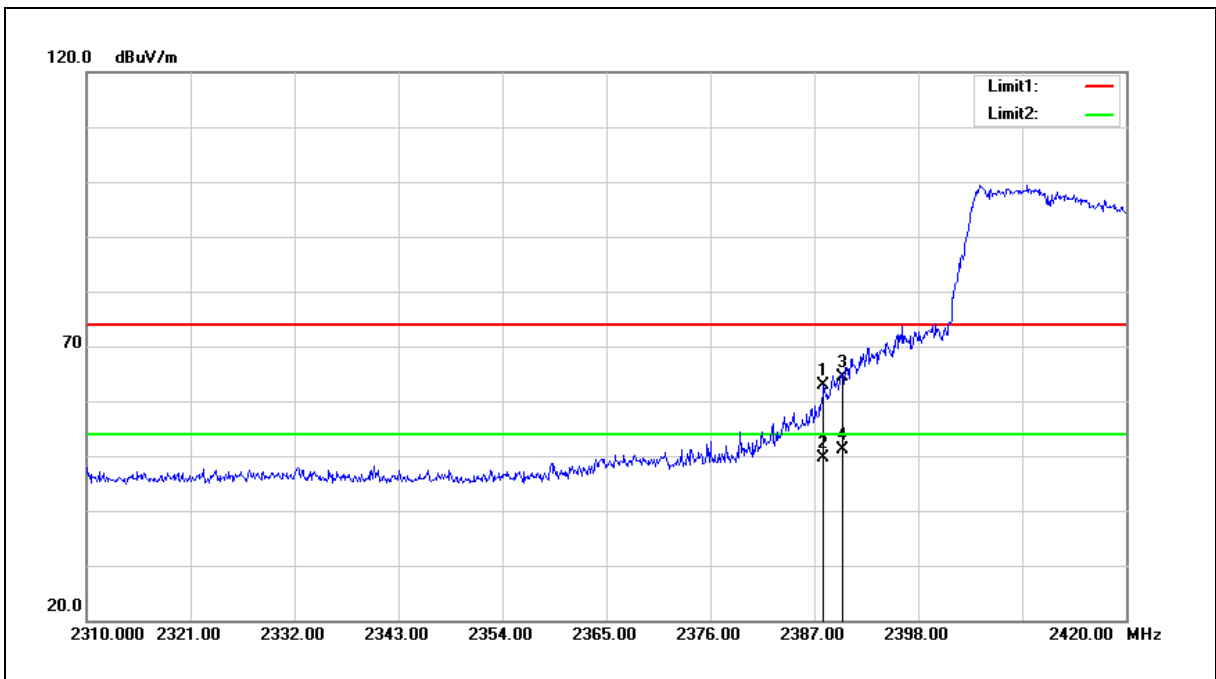

No.	Frequency (MHz)	Reading (dBuV)	Correct Factor (dB/m)	Result (dBuV/m)	Limit (dBuV/m)	Margin (dB)	Remark
1	2387.990	72.50	-9.63	62.87	74.00	-11.13	peak
2	2387.990	59.19	-9.63	49.56	54.00	-4.44	AVG
3	2390.000	74.07	-9.62	64.45	74.00	-9.55	peak
4	2390.000	60.78	-9.62	51.16	54.00	-2.84	AVG

Note:1.Result (dBuV/m) = Correct Factor (dB/m) + Reading(dBuV).

2.Correction factor (dB/m) = Antenna Factor (dB/m) + Cable loss (dB) – Pre-Amplifier gain (dB).

3.When the peak results are less than average limit, so not need to evaluate the average.



Standard:	FCC Part 15.247	Test Distance:	3 m
Test item:	Band edge	Power:	DC 3.3 V
Frequency:	2437 MHz	Temp.(°C)/Hum.(%RH):	26(°C)/60 %RH
Mode:	Mode 3		
Ant.Polar.:	Horizontal		

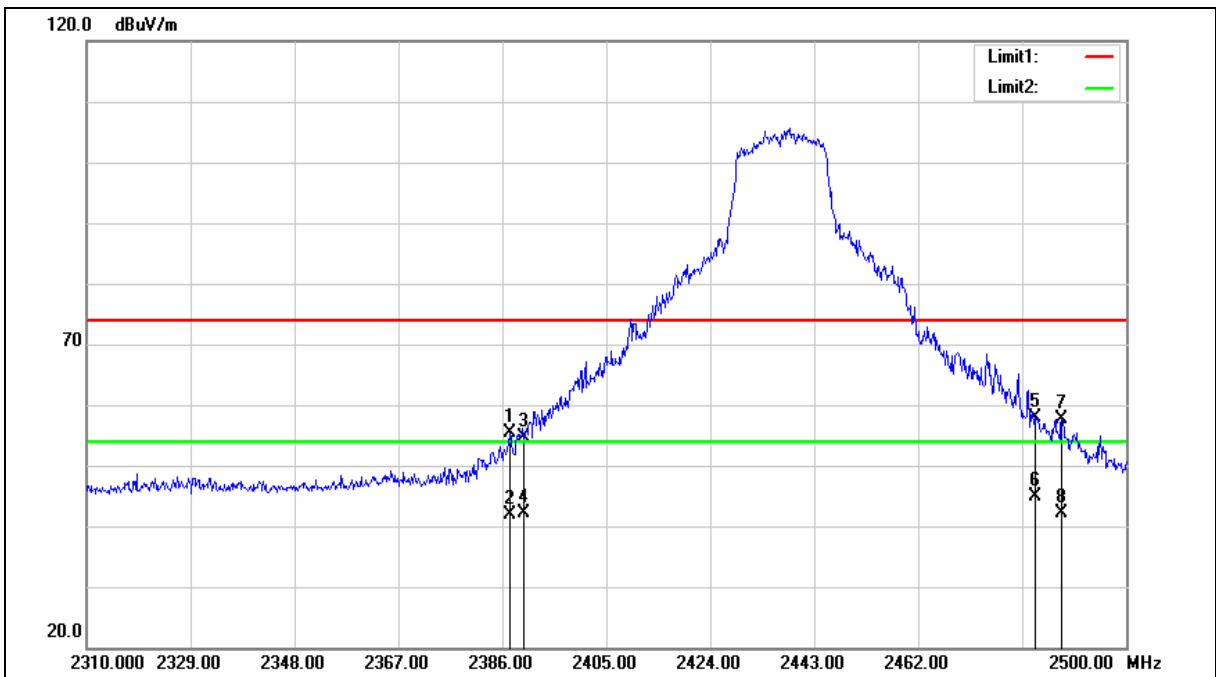



Standard:	FCC Part 15.247	Test Distance:	3 m
Test item:	Band edge	Power:	DC 3.3 V
Frequency:	2437 MHz	Temp.(°C)/Hum.(%RH):	26(°C)/60 %RH
Mode:	Mode 3		
Ant.Polar.:	Horizontal		

No.	Frequency (MHz)	Reading (dBuV)	Correct Factor (dB/m)	Result (dBuV/m)	Limit (dBuV/m)	Margin (dB)	Remark
1	2387.330	64.92	-9.64	55.28	74.00	-18.72	peak
2	2387.330	51.57	-9.64	41.93	54.00	-12.07	AVG
3	2390.000	64.21	-9.62	54.59	74.00	-19.41	peak
4	2390.000	51.70	-9.62	42.08	54.00	-11.92	AVG
5	2483.500	67.21	-9.37	57.84	74.00	-16.16	peak
6	2483.500	54.24	-9.37	44.87	54.00	-9.13	AVG
7	2488.220	67.06	-9.36	57.70	74.00	-16.30	peak
8	2488.220	51.42	-9.36	42.06	54.00	-11.94	AVG

Note:1.Result (dBuV/m) = Correct Factor (dB/m) + Reading(dBuV).

2.Correction factor (dB/m) = Antenna Factor (dB/m) + Cable loss (dB) – Pre-Amplifier gain (dB).

3.When the peak results are less than average limit, so not need to evaluate the average.



Standard:	FCC Part 15.247	Test Distance:	3 m
Test item:	Band edge	Power:	DC 3.3 V
Frequency:	2437 MHz	Temp.(°C)/Hum.(%RH):	26(°C)/60 %RH
Mode:	Mode 3		
Ant.Polar.:	Vertical		

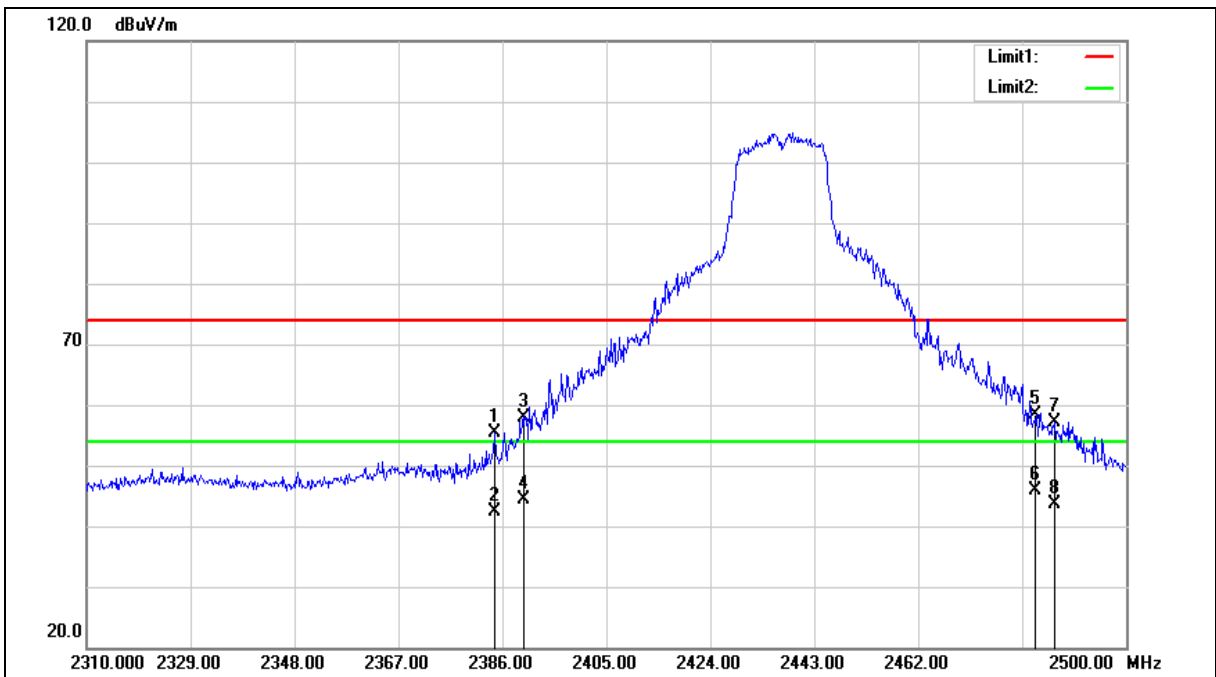



Standard:	FCC Part 15.247	Test Distance:	3 m
Test item:	Band edge	Power:	DC 3.3 V
Frequency:	2437 MHz	Temp.(°C)/Hum.(%RH):	26(°C)/60 %RH
Mode:	Mode 3		
Ant.Polar.:	Vertical		

No.	Frequency (MHz)	Reading (dBuV)	Correct Factor (dB/m)	Result (dBuV/m)	Limit (dBuV/m)	Margin (dB)	Remark
1	2384.670	65.13	-9.65	55.48	74.00	-18.52	peak
2	2384.670	51.96	-9.65	42.31	54.00	-11.69	AVG
3	2390.000	67.59	-9.62	57.97	74.00	-16.03	peak
4	2390.000	53.91	-9.62	44.29	54.00	-9.71	AVG
5	2483.500	67.81	-9.37	58.44	74.00	-15.56	peak
6	2483.500	55.19	-9.37	45.82	54.00	-8.18	AVG
7	2486.890	66.47	-9.37	57.10	74.00	-16.90	peak
8	2486.890	53.12	-9.37	43.75	54.00	-10.25	AVG

Note:1.Result (dBuV/m) = Correct Factor (dB/m) + Reading(dBuV).

2.Correction factor (dB/m) = Antenna Factor (dB/m) + Cable loss (dB) – Pre-Amplifier gain (dB).

3.When the peak results are less than average limit, so not need to evaluate the average.



Standard:	FCC Part 15.247	Test Distance:	3 m
Test item:	Band edge	Power:	DC 3.3 V
Frequency:	2462 MHz	Temp.(°C)/Hum.(%RH):	26(°C)/60 %RH
Mode:	Mode 3		
Ant.Polar.:	Horizontal		

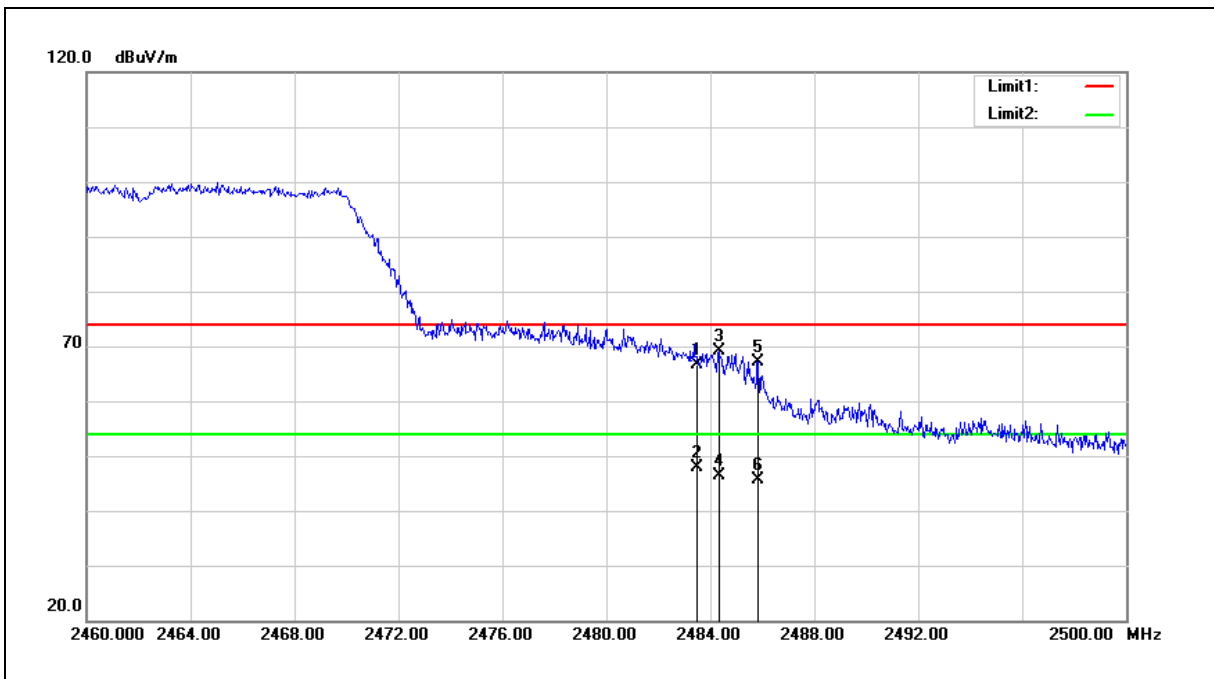

No.	Frequency (MHz)	Reading (dBuV)	Correct Factor (dB/m)	Result (dBuV/m)	Limit (dBuV/m)	Margin (dB)	Remark
1	2483.500	75.91	-9.37	66.54	74.00	-7.46	peak
2	2483.500	57.27	-9.37	47.90	54.00	-6.10	AVG
3	2484.320	78.47	-9.37	69.10	74.00	-4.90	peak
4	2484.320	55.64	-9.37	46.27	54.00	-7.73	AVG
5	2485.840	76.47	-9.37	67.10	74.00	-6.90	peak
6	2485.840	54.98	-9.37	45.61	54.00	-8.39	AVG

Note:1.Result (dBuV/m) = Correct Factor (dB/m) + Reading(dBuV).

2.Correction factor (dB/m) = Antenna Factor (dB/m) + Cable loss (dB) – Pre-Amplifier gain (dB).

3.When the peak results are less than average limit, so not need to evaluate the average.



Standard:	FCC Part 15.247	Test Distance:	3 m
Test item:	Band edge	Power:	DC 3.3 V
Frequency:	2462 MHz	Temp.(°C)/Hum.(%RH):	26(°C)/60 %RH
Mode:	Mode 3		
Ant.Polar.:	Vertical		

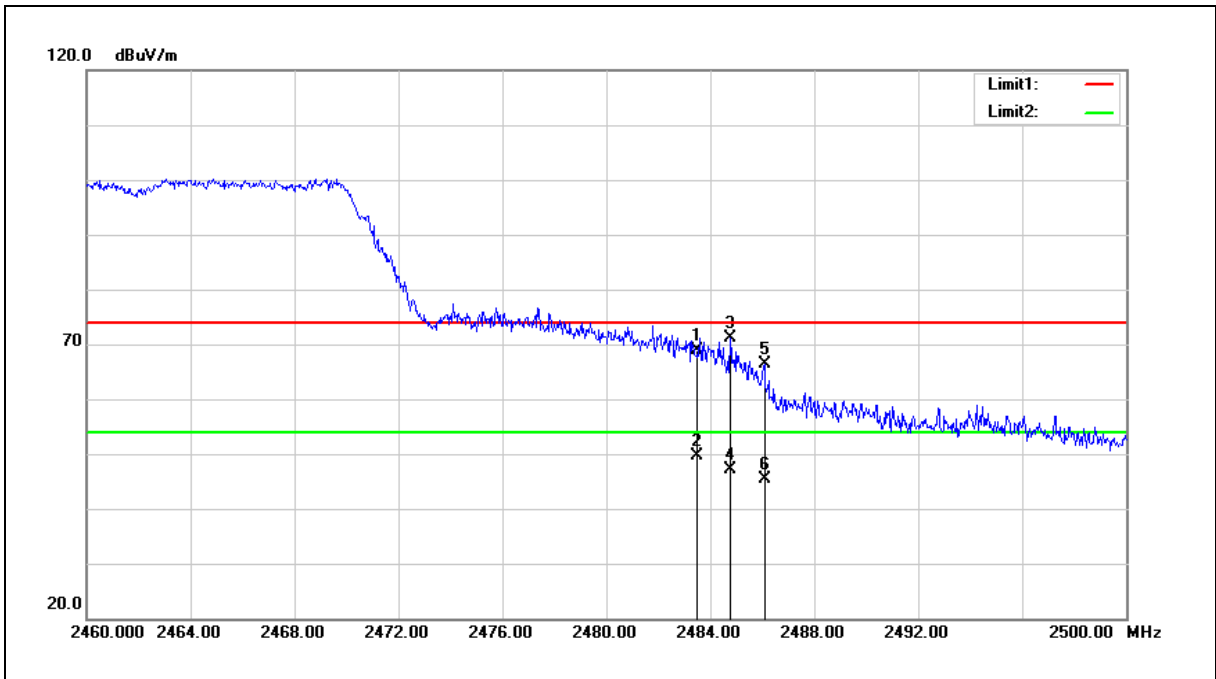

No.	Frequency (MHz)	Reading (dBuV)	Correct Factor (dB/m)	Result (dBuV/m)	Limit (dBuV/m)	Margin (dB)	Remark
1	2483.500	78.20	-9.37	68.83	74.00	-5.17	peak
2	2483.500	59.11	-9.37	49.74	54.00	-4.26	AVG
3	2484.760	80.42	-9.37	71.05	74.00	-2.95	peak
4	2484.760	56.61	-9.37	47.24	54.00	-6.76	AVG
5	2486.080	75.66	-9.37	66.29	74.00	-7.71	peak
6	2486.080	54.73	-9.37	45.36	54.00	-8.64	AVG

Note:1.Result (dBuV/m) = Correct Factor (dB/m) + Reading(dBuV).

2.Correction factor (dB/m) = Antenna Factor (dB/m) + Cable loss (dB) – Pre-Amplifier gain (dB).

3.When the peak results are less than average limit, so not need to evaluate the average.



Standard:	FCC Part 15.247	Test Distance:	3 m
Test item:	Band edge	Power:	DC 3.3 V
Frequency:	2412 MHz	Temp.(°C)/Hum.(%RH):	26(°C)/60 %RH
Mode:	Mode 4		
Ant.Polar.:	Horizontal		

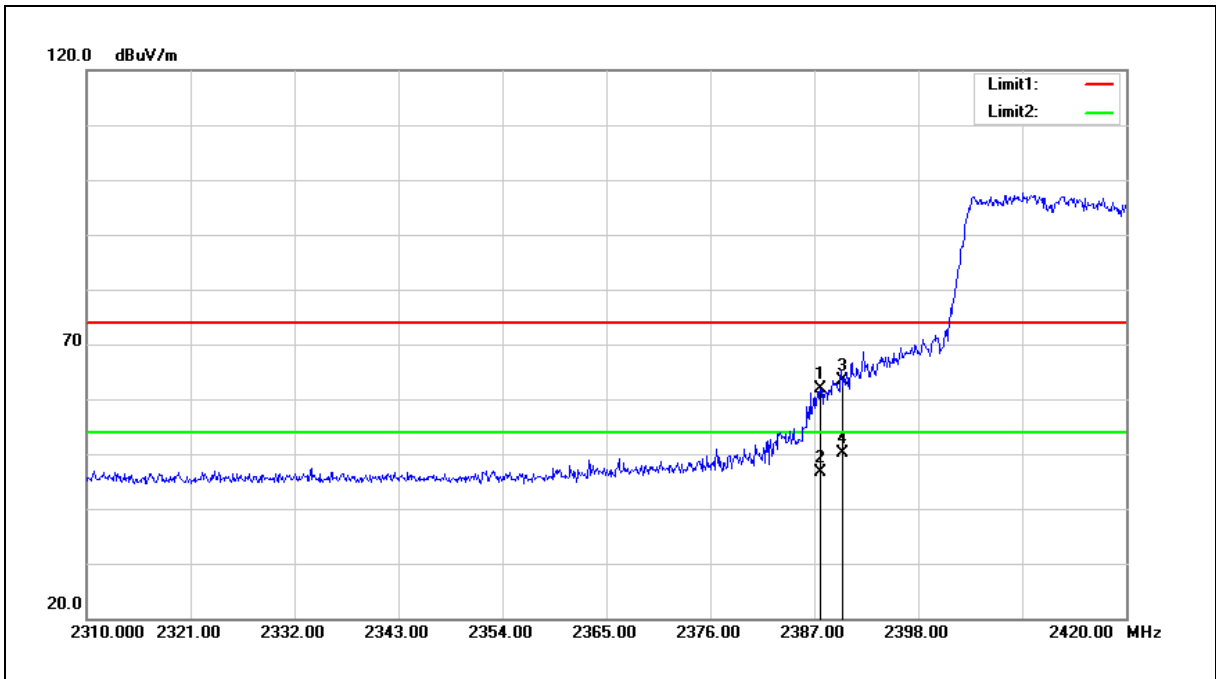

No.	Frequency (MHz)	Reading (dBuV)	Correct Factor (dB/m)	Result (dBuV/m)	Limit (dBuV/m)	Margin (dB)	Remark
1	2387.660	71.41	-9.63	61.78	74.00	-12.22	peak
2	2387.660	56.21	-9.63	46.58	54.00	-7.42	AVG
3	2390.000	72.92	-9.62	63.30	74.00	-10.70	peak
4	2390.000	59.84	-9.62	50.22	54.00	-3.78	AVG

Note:1.Result (dBuV/m) = Correct Factor (dB/m) + Reading(dBuV).

2.Correction factor (dB/m) = Antenna Factor (dB/m) + Cable loss (dB) – Pre-Amplifier gain (dB).

3.When the peak results are less than average limit, so not need to evaluate the average.



Standard:	FCC Part 15.247	Test Distance:	3 m
Test item:	Band edge	Power:	DC 3.3 V
Frequency:	2412 MHz	Temp.(°C)/Hum.(%RH):	26(°C)/60 %RH
Mode:	Mode 4		
Ant.Polar.:	Vertical		

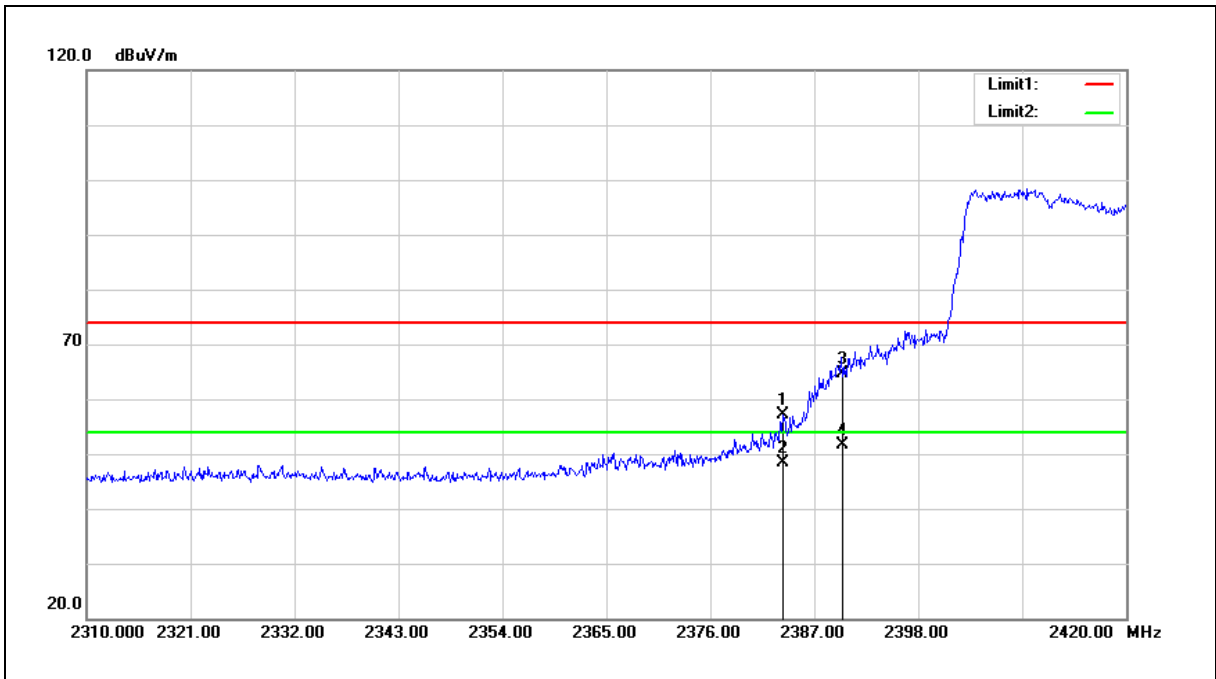

No.	Frequency (MHz)	Reading (dBuV)	Correct Factor (dB/m)	Result (dBuV/m)	Limit (dBuV/m)	Margin (dB)	Remark
1	2383.700	66.78	-9.65	57.13	74.00	-16.87	peak
2	2383.700	57.91	-9.65	48.26	54.00	-5.74	AVG
3	2390.000	74.34	-9.62	64.72	74.00	-9.28	peak
4	2390.000	61.20	-9.62	51.58	54.00	-2.42	AVG

- Note:1.Result (dBuV/m) = Correct Factor (dB/m) + Reading(dBuV).
- 2.Correction factor (dB/m) = Antenna Factor (dB/m) + Cable loss (dB) – Pre-Amplifier gain (dB).
- 3.When the peak results are less than average limit, so not need to evaluate the average.



Standard:	FCC Part 15.247	Test Distance:	3 m
Test item:	Band edge	Power:	DC 3.3 V
Frequency:	2437 MHz	Temp.(°C)/Hum.(%RH):	26(°C)/60 %RH
Mode:	Mode 4		
Ant.Polar.:	Horizontal		

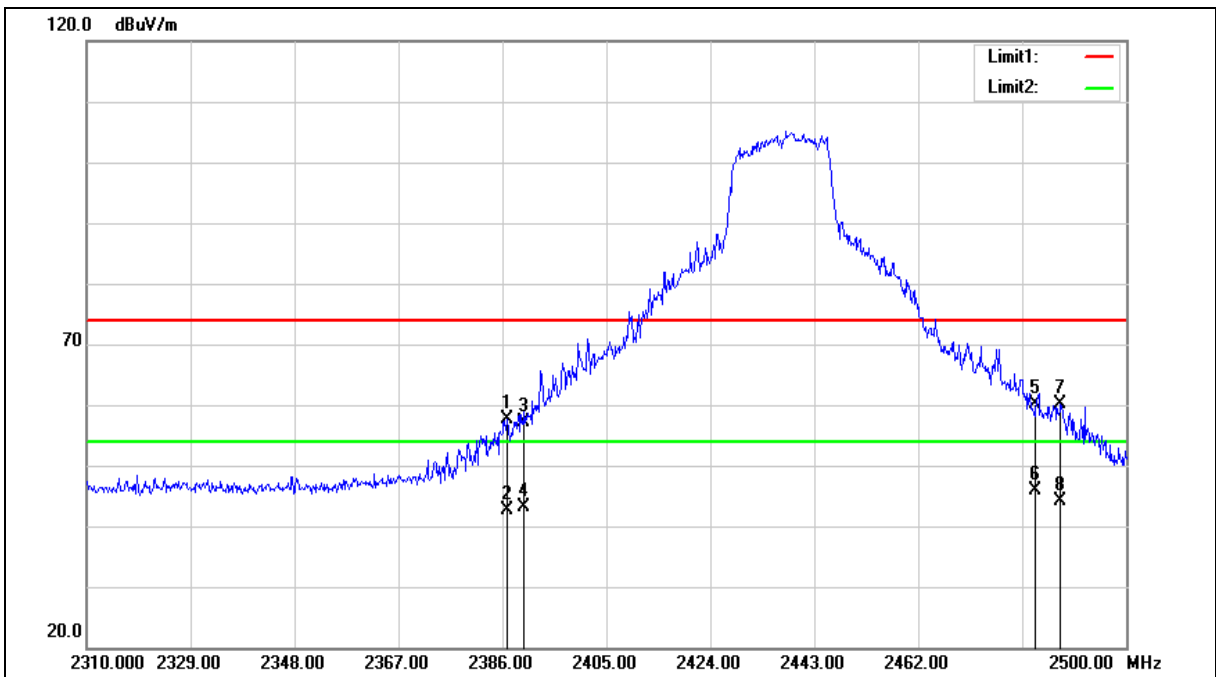



Standard:	FCC Part 15.247	Test Distance:	3 m
Test item:	Band edge	Power:	DC 3.3 V
Frequency:	2437 MHz	Temp.(°C)/Hum.(%RH):	26(°C)/60 %RH
Mode:	Mode 4		
Ant.Polar.:	Horizontal		

No.	Frequency (MHz)	Reading (dBuV)	Correct Factor (dB/m)	Result (dBuV/m)	Limit (dBuV/m)	Margin (dB)	Remark
1	2386.760	67.22	-9.64	57.58	74.00	-16.42	peak
2	2386.760	52.27	-9.64	42.63	54.00	-11.37	AVG
3	2390.000	66.81	-9.62	57.19	74.00	-16.81	peak
4	2390.000	52.64	-9.62	43.02	54.00	-10.98	AVG
5	2483.500	69.38	-9.37	60.01	74.00	-13.99	peak
6	2483.500	55.15	-9.37	45.78	54.00	-8.22	AVG
7	2488.030	69.49	-9.36	60.13	74.00	-13.87	peak
8	2488.030	53.52	-9.36	44.16	54.00	-9.84	AVG

Note:1.Result (dBuV/m) = Correct Factor (dB/m) + Reading(dBuV).

2.Correction factor (dB/m) = Antenna Factor (dB/m) + Cable loss (dB) – Pre-Amplifier gain (dB).

3.When the peak results are less than average limit, so not need to evaluate the average.



Standard:	FCC Part 15.247	Test Distance:	3 m
Test item:	Band edge	Power:	DC 3.3 V
Frequency:	2437 MHz	Temp.(°C)/Hum.(%RH):	26(°C)/60 %RH
Mode:	Mode 4		
Ant.Polar.:	Vertical		

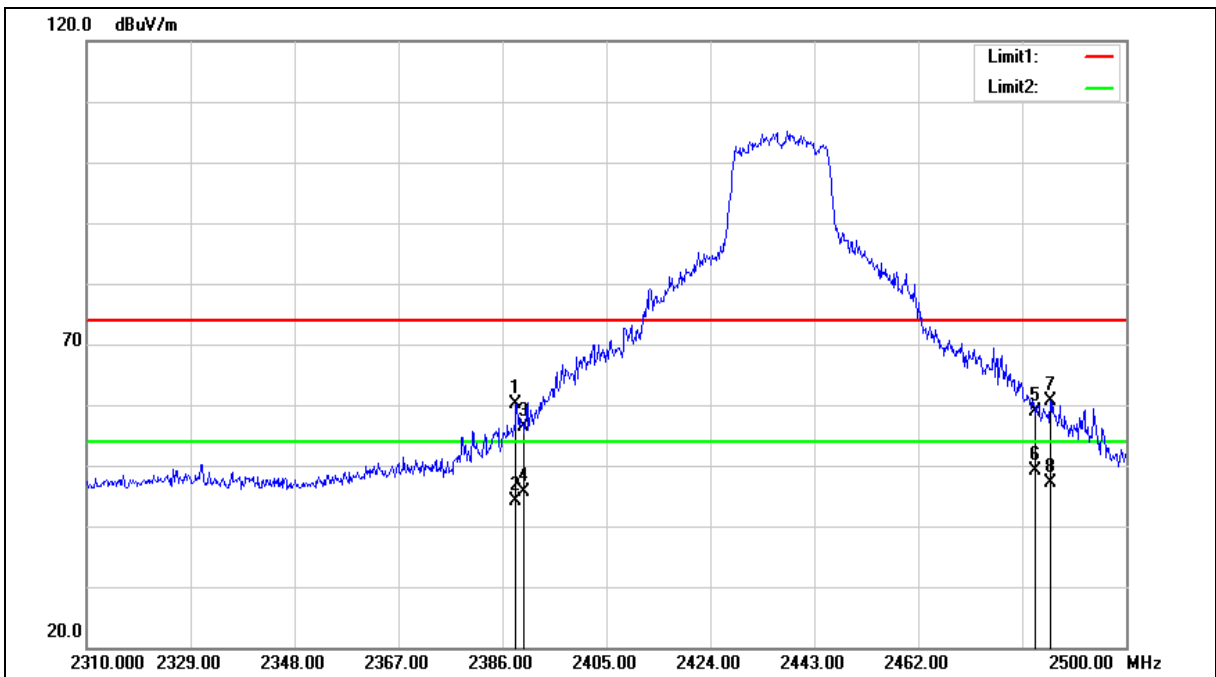



Standard:	FCC Part 15.247	Test Distance:	3 m
Test item:	Band edge	Power:	DC 3.3 V
Frequency:	2437 MHz	Temp.(°C)/Hum.(%RH):	26(°C)/60 %RH
Mode:	Mode 4		
Ant.Polar.:	Vertical		

No.	Frequency (MHz)	Reading (dBuV)	Correct Factor (dB/m)	Result (dBuV/m)	Limit (dBuV/m)	Margin (dB)	Remark
1	2388.470	69.81	-9.63	60.18	74.00	-13.82	peak
2	2388.470	53.84	-9.63	44.21	54.00	-9.79	AVG
3	2390.000	65.90	-9.62	56.28	74.00	-17.72	peak
4	2390.000	55.28	-9.62	45.66	54.00	-8.34	AVG
5	2483.500	68.26	-9.37	58.89	74.00	-15.11	peak
6	2483.500	58.43	-9.37	49.06	54.00	-4.94	AVG
7	2486.130	70.03	-9.37	60.66	74.00	-13.34	peak
8	2486.130	56.54	-9.37	47.17	54.00	-6.83	AVG

Note:1.Result (dBuV/m) = Correct Factor (dB/m) + Reading(dBuV).

2.Correction factor (dB/m) = Antenna Factor (dB/m) + Cable loss (dB) – Pre-Amplifier gain (dB).

3.When the peak results are less than average limit, so not need to evaluate the average.



Standard:	FCC Part 15.247	Test Distance:	3 m
Test item:	Band edge	Power:	DC 3.3 V
Frequency:	2462 MHz	Temp.(°C)/Hum.(%RH):	26(°C)/60 %RH
Mode:	Mode 4		
Ant.Polar.:	Horizontal		

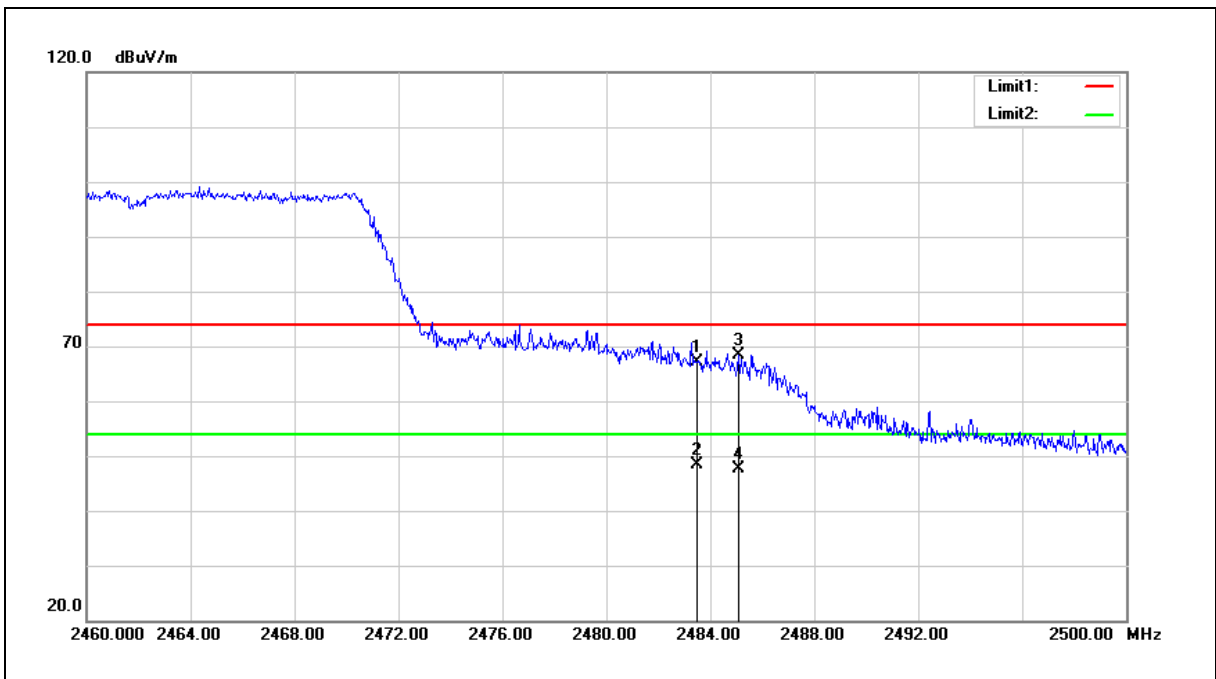

No.	Frequency (MHz)	Reading (dBuV)	Correct Factor (dB/m)	Result (dBuV/m)	Limit (dBuV/m)	Margin (dB)	Remark
1	2483.500	76.48	-9.37	67.11	74.00	-6.89	peak
2	2483.500	57.84	-9.37	48.47	54.00	-5.53	AVG
3	2485.080	77.69	-9.37	68.32	74.00	-5.68	peak
4	2485.080	56.92	-9.37	47.55	54.00	-6.45	AVG

Note:1.Result (dBuV/m) = Correct Factor (dB/m) + Reading(dBuV).

2.Correction factor (dB/m) = Antenna Factor (dB/m) + Cable loss (dB) – Pre-Amplifier gain (dB).

3.When the peak results are less than average limit, so not need to evaluate the average.



Standard:	FCC Part 15.247	Test Distance:	3 m
Test item:	Band edge	Power:	DC 3.3 V
Frequency:	2462 MHz	Temp.(°C)/Hum.(%RH):	26(°C)/60 %RH
Mode:	Mode 4		
Ant.Polar.:	Vertical		

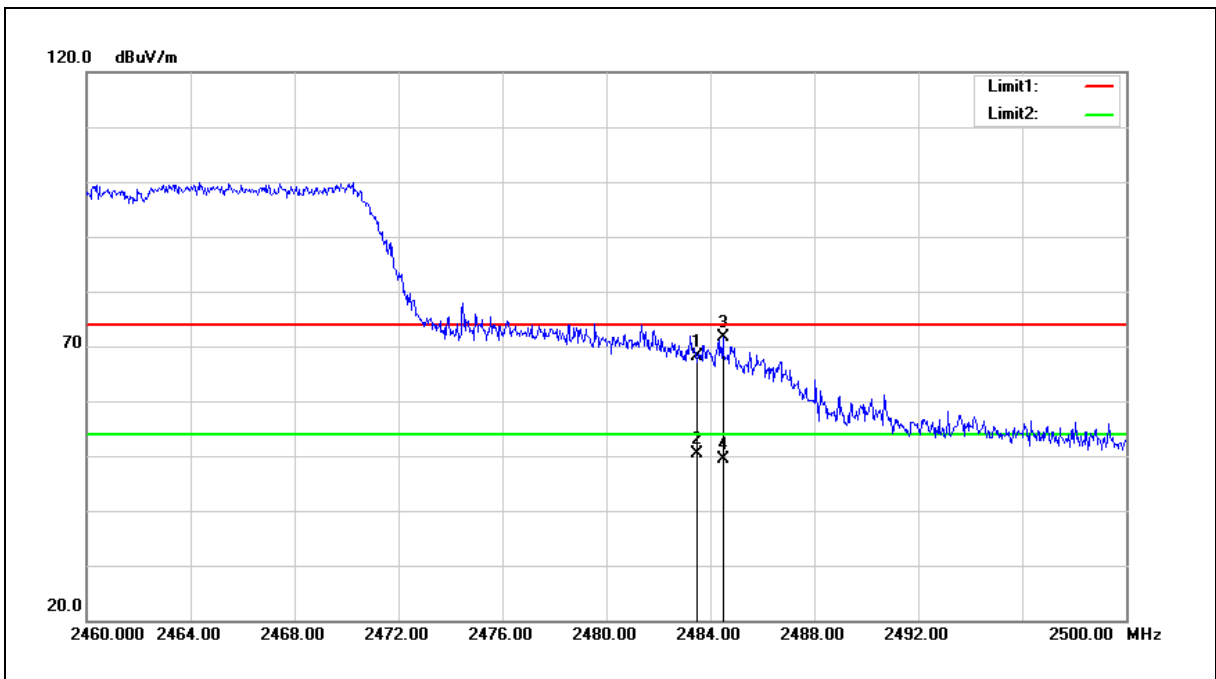

No.	Frequency (MHz)	Reading (dBuV)	Correct Factor (dB/m)	Result (dBuV/m)	Limit (dBuV/m)	Margin (dB)	Remark
1	2483.500	77.40	-9.37	68.03	74.00	-5.97	peak
2	2483.500	59.70	-9.37	50.33	54.00	-3.67	AVG
3	2484.480	80.90	-9.37	71.53	74.00	-2.47	peak
4	2484.480	58.82	-9.37	49.45	54.00	-4.55	AVG

Note:1.Result (dBuV/m) = Correct Factor (dB/m) + Reading(dBuV).

2.Correction factor (dB/m) = Antenna Factor (dB/m) + Cable loss (dB) – Pre-Amplifier gain (dB).

3.When the peak results are less than average limit, so not need to evaluate the average.



Standard:	FCC Part 15.247	Test Distance:	3 m
Test item:	Band edge	Power:	DC 3.3 V
Frequency:	2422MHz	Temp.(°C)/Hum.(%RH):	26(°C)/60 %RH
Mode:	Mode 5		
Ant.Polar.:	Horizontal		

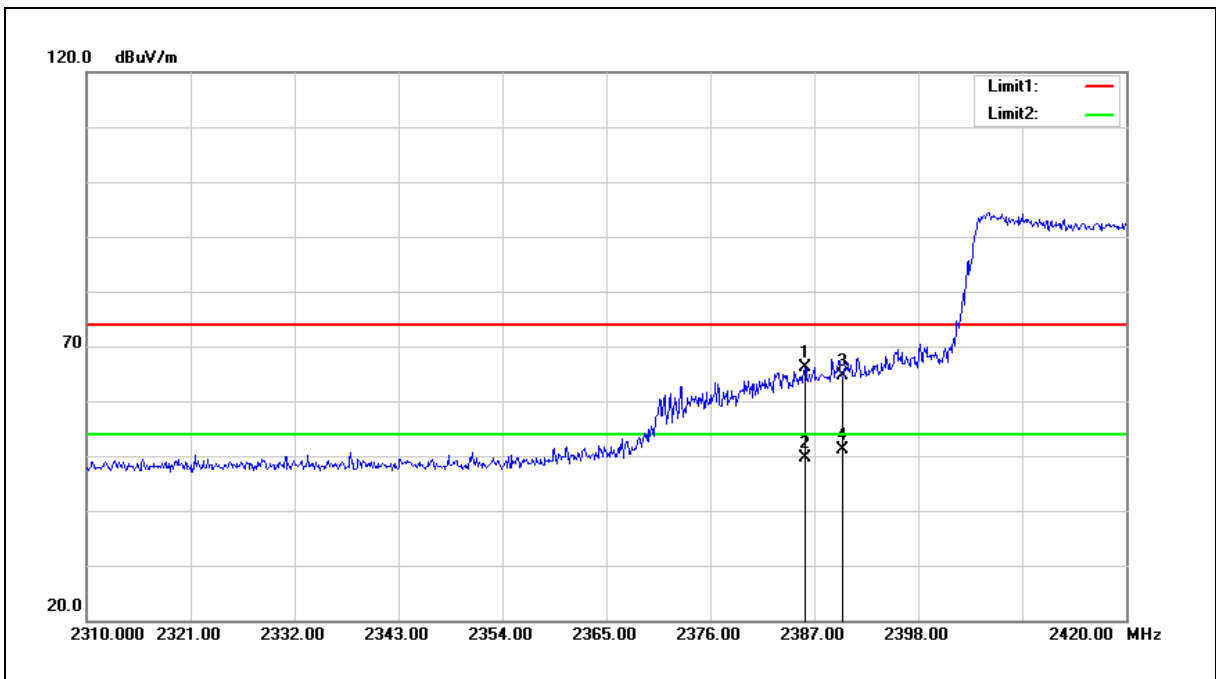

No.	Frequency (MHz)	Reading (dBuV)	Correct Factor (dB/m)	Result (dBuV/m)	Limit (dBuV/m)	Margin (dB)	Remark
1	2386.010	75.83	-9.64	66.19	74.00	-7.81	peak
2	2386.010	59.36	-9.64	49.72	54.00	-4.28	AVG
3	2390.000	74.14	-9.62	64.52	74.00	-9.48	peak
4	2390.000	60.72	-9.62	51.10	54.00	-2.90	AVG

Note:1.Result (dBuV/m) = Correct Factor (dB/m) + Reading(dBuV).

2.Correction factor (dB/m) = Antenna Factor (dB/m) + Cable loss (dB) – Pre-Amplifier gain (dB).

3.When the peak results are less than average limit, so not need to evaluate the average.



Standard:	FCC Part 15.247	Test Distance:	3 m
Test item:	Band edge	Power:	DC 3.3 V
Frequency:	2422MHz	Temp.(°C)/Hum.(%RH):	26(°C)/60 %RH
Mode:	Mode 5		
Ant.Polar.:	Vertical		

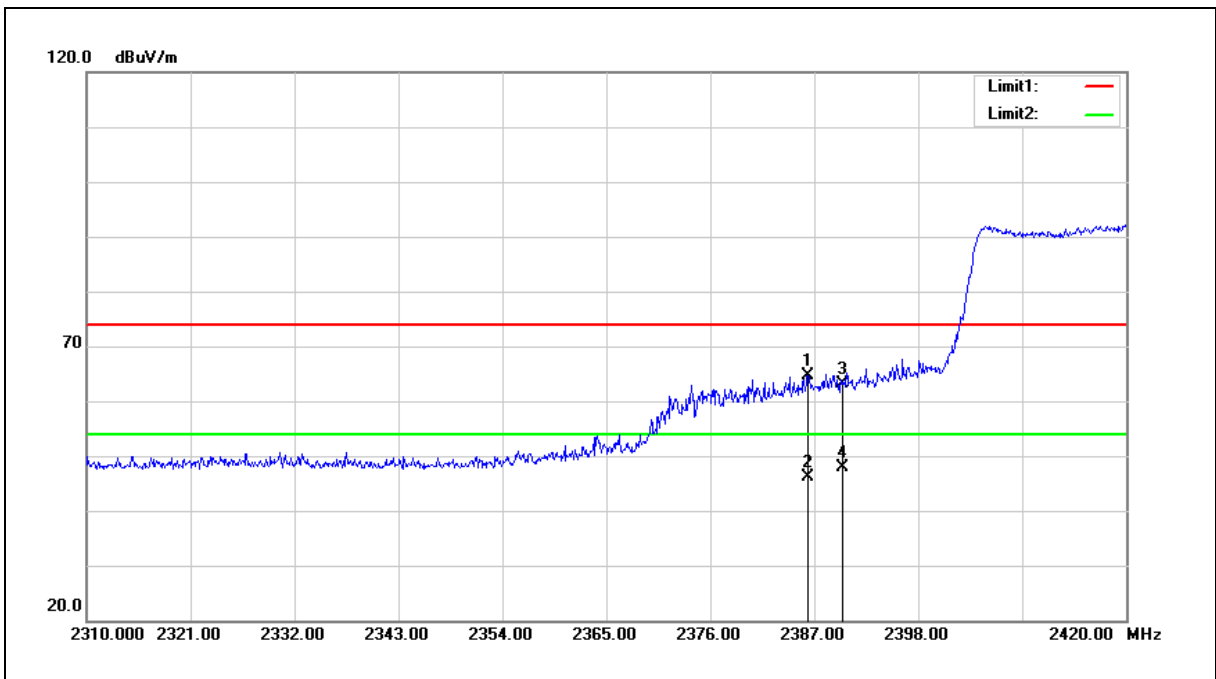

No.	Frequency (MHz)	Reading (dBuV)	Correct Factor (dB/m)	Result (dBuV/m)	Limit (dBuV/m)	Margin (dB)	Remark
1	2386.340	74.25	-9.64	64.61	74.00	-9.39	peak
2	2386.340	55.77	-9.64	46.13	54.00	-7.87	AVG
3	2390.000	72.75	-9.62	63.13	74.00	-10.87	peak
4	2390.000	57.50	-9.62	47.88	54.00	-6.12	AVG

Note:1.Result (dBuV/m) = Correct Factor (dB/m) + Reading(dBuV).

2.Correction factor (dB/m) = Antenna Factor (dB/m) + Cable loss (dB) – Pre-Amplifier gain (dB).

3.When the peak results are less than average limit, so not need to evaluate the average.



Standard:	FCC Part 15.247	Test Distance:	3 m
Test item:	Band edge	Power:	DC 3.3 V
Frequency:	2437 MHz	Temp.(°C)/Hum.(%RH):	26(°C)/60 %RH
Mode:	Mode 5		
Ant.Polar.:	Horizontal		

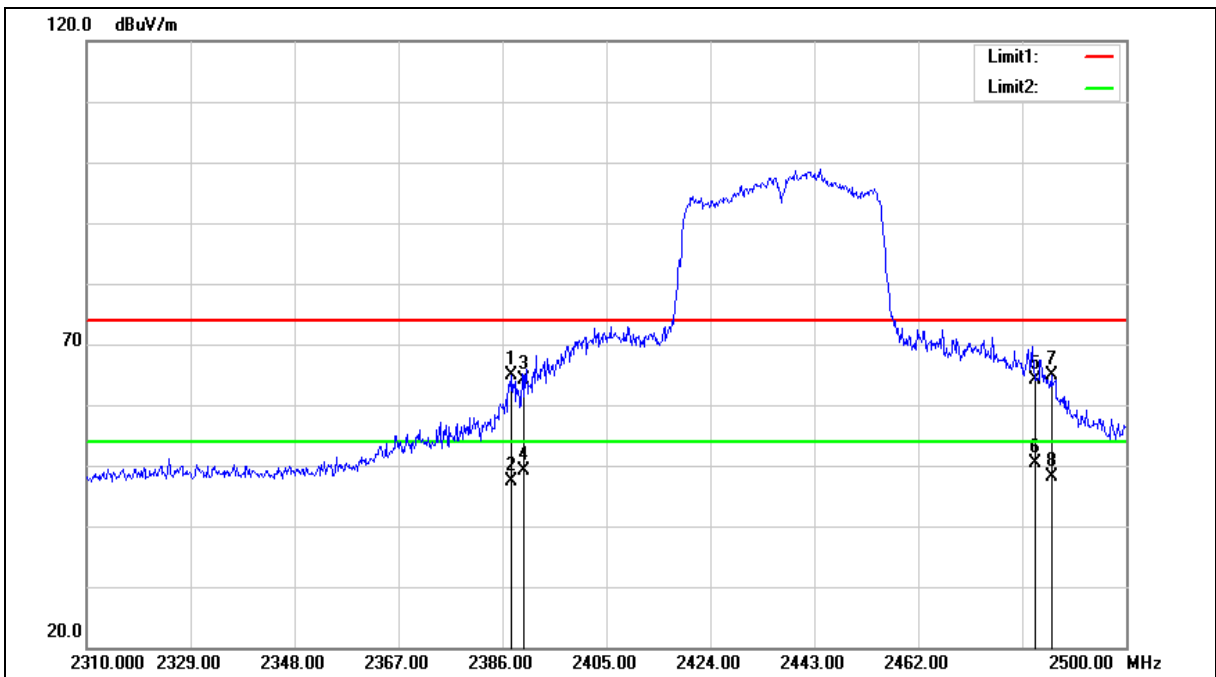



Standard:	FCC Part 15.247	Test Distance:	3 m
Test item:	Band edge	Power:	DC 3.3 V
Frequency:	2437 MHz	Temp.(°C)/Hum.(%RH):	26(°C)/60 %RH
Mode:	Mode 5		
Ant.Polar.:	Horizontal		

No.	Frequency (MHz)	Reading (dBuV)	Correct Factor (dB/m)	Result (dBuV/m)	Limit (dBuV/m)	Margin (dB)	Remark
1	2387.710	74.46	-9.63	64.83	74.00	-9.17	peak
2	2387.710	56.98	-9.63	47.35	54.00	-6.65	AVG
3	2390.000	73.63	-9.62	64.01	74.00	-9.99	peak
4	2390.000	58.80	-9.62	49.18	54.00	-4.82	AVG
5	2483.500	73.54	-9.37	64.17	74.00	-9.83	peak
6	2483.500	59.66	-9.37	50.29	54.00	-3.71	AVG
7	2486.320	74.35	-9.37	64.98	74.00	-9.02	peak
8	2486.320	57.54	-9.37	48.17	54.00	-5.83	AVG

Note:1.Result (dBuV/m) = Correct Factor (dB/m) + Reading(dBuV).

2.Correction factor (dB/m) = Antenna Factor (dB/m) + Cable loss (dB) – Pre-Amplifier gain (dB).

3.When the peak results are less than average limit, so not need to evaluate the average.



Standard:	FCC Part 15.247	Test Distance:	3 m
Test item:	Band edge	Power:	DC 3.3 V
Frequency:	2437 MHz	Temp.(°C)/Hum.(%RH):	26(°C)/60 %RH
Mode:	Mode 5		
Ant.Polar.:	Vertical		

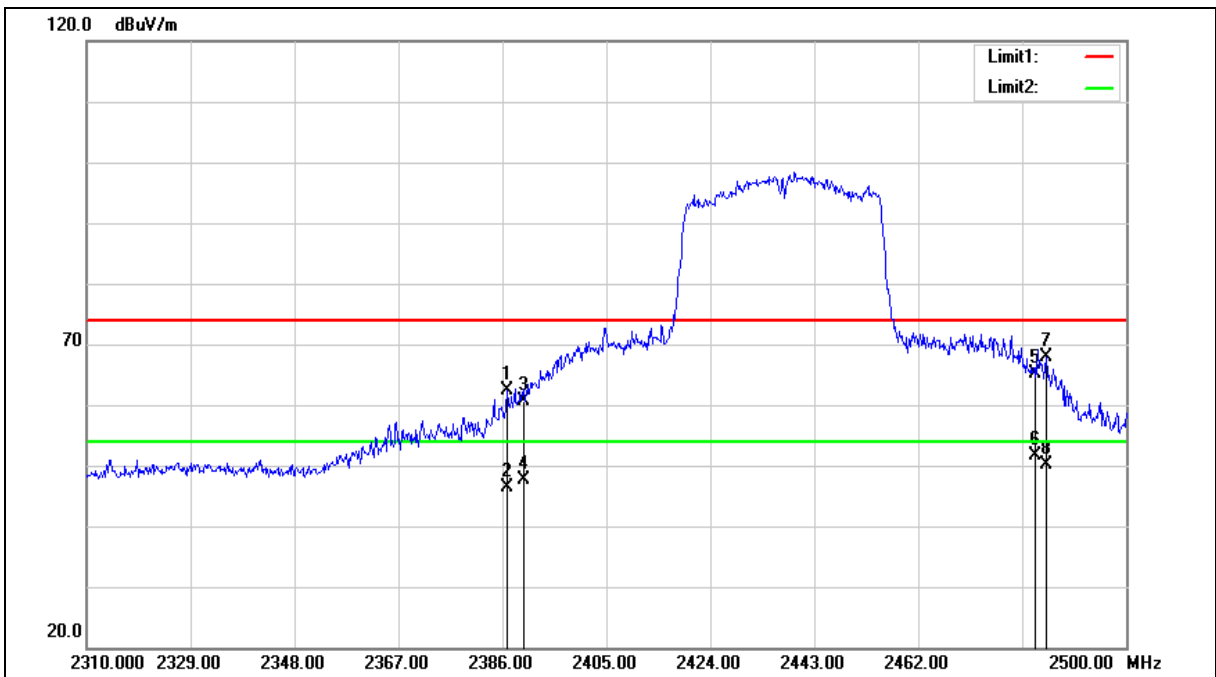



Standard:	FCC Part 15.247	Test Distance:	3 m
Test item:	Band edge	Power:	DC 3.3 V
Frequency:	2437 MHz	Temp.(°C)/Hum.(%RH):	26(°C)/60 %RH
Mode:	Mode 5		
Ant.Polar.:	Vertical		

No.	Frequency (MHz)	Reading (dBuV)	Correct Factor (dB/m)	Result (dBuV/m)	Limit (dBuV/m)	Margin (dB)	Remark
1	2386.950	72.01	-9.64	62.37	74.00	-11.63	peak
2	2386.950	56.00	-9.64	46.36	54.00	-7.64	AVG
3	2390.000	70.37	-9.62	60.75	74.00	-13.25	peak
4	2390.000	57.37	-9.62	47.75	54.00	-6.25	AVG
5	2483.500	74.45	-9.37	65.08	74.00	-8.92	peak
6	2483.500	61.00	-9.37	51.63	54.00	-2.37	AVG
7	2485.370	77.19	-9.37	67.82	74.00	-6.18	peak
8	2485.370	59.61	-9.37	50.24	54.00	-3.76	AVG

Note:1.Result (dBuV/m) = Correct Factor (dB/m) + Reading(dBuV).

2.Correction factor (dB/m) = Antenna Factor (dB/m) + Cable loss (dB) – Pre-Amplifier gain (dB).

3.When the peak results are less than average limit, so not need to evaluate the average.



Standard:	FCC Part 15.247	Test Distance:	3 m
Test item:	Band edge	Power:	DC 3.3 V
Frequency:	2452 MHz	Temp.(°C)/Hum.(%RH):	26(°C)/60 %RH
Mode:	Mode 5		
Ant.Polar.:	Horizontal		

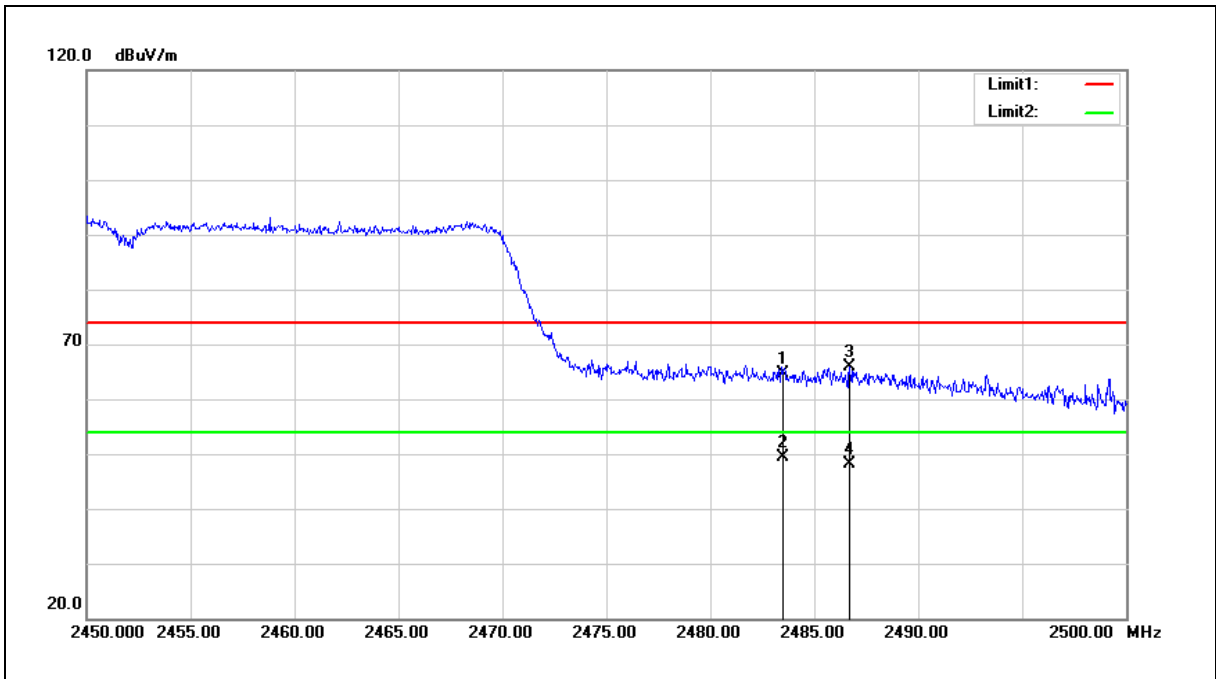

No.	Frequency (MHz)	Reading (dBuV)	Correct Factor (dB/m)	Result (dBuV/m)	Limit (dBuV/m)	Margin (dB)	Remark
1	2483.500	74.10	-9.37	64.73	74.00	-9.27	peak
2	2483.500	58.75	-9.37	49.38	54.00	-4.62	AVG
3	2486.700	75.20	-9.37	65.83	74.00	-8.17	peak
4	2486.700	57.59	-9.37	48.22	54.00	-5.78	AVG

- Note:1.Result (dBuV/m) = Correct Factor (dB/m) + Reading(dBuV).
- 2.Correction factor (dB/m) = Antenna Factor (dB/m) + Cable loss (dB) – Pre-Amplifier gain (dB).
- 3.When the peak results are less than average limit, so not need to evaluate the average.

Standard:	FCC Part 15.247	Test Distance:	3 m
Test item:	Band edge	Power:	DC 3.3 V
Frequency:	2452 MHz	Temp.(°C)/Hum.(%RH):	26(°C)/60 %RH
Mode:	Mode 5		
Ant.Polar.:	Vertical		

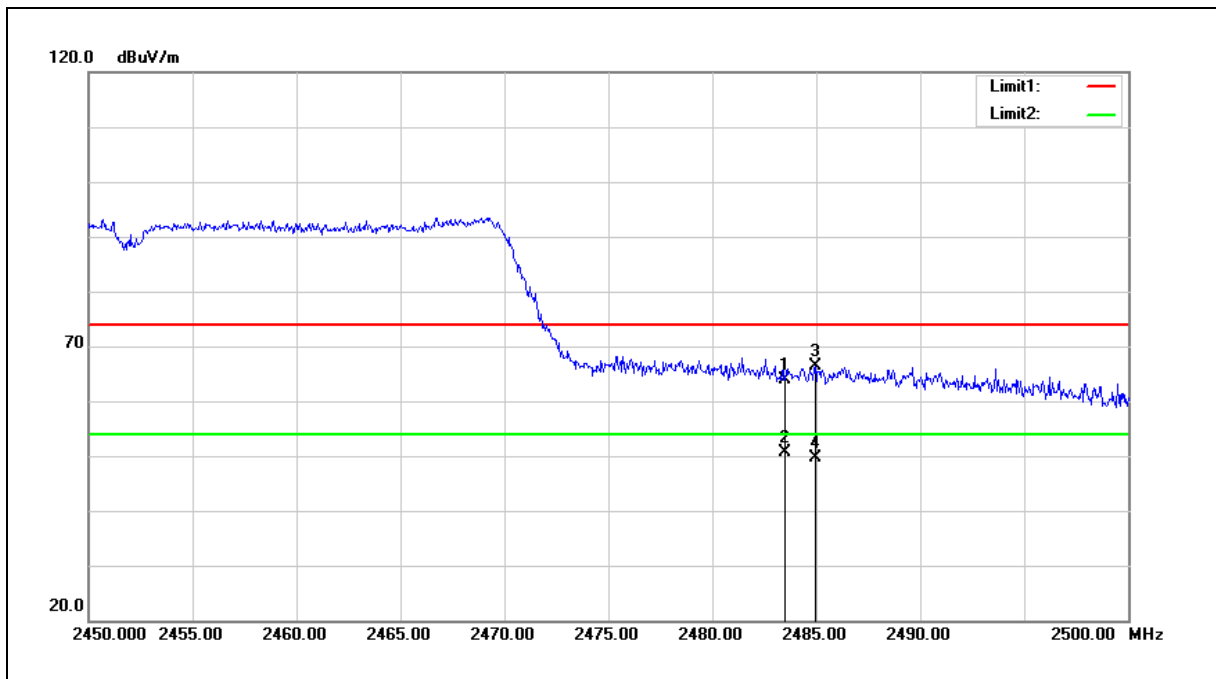

No.	Frequency (MHz)	Reading (dBuV)	Correct Factor (dB/m)	Result (dBuV/m)	Limit (dBuV/m)	Margin (dB)	Remark
1	2483.500	73.20	-9.37	63.83	74.00	-10.17	peak
2	2483.500	60.04	-9.37	50.67	54.00	-3.33	AVG
3	2484.950	75.76	-9.37	66.39	74.00	-7.61	peak
4	2484.950	58.88	-9.37	49.51	54.00	-4.49	AVG

Note:1.Result (dBuV/m) = Correct Factor (dB/m) + Reading(dBuV).

2.Correction factor (dB/m) = Antenna Factor (dB/m) + Cable loss (dB) – Pre-Amplifier gain (dB).

3.When the peak results are less than average limit, so not need to evaluate the average.