

## RF Test Report

Applicant : Redpine Signals, Inc.  
Product Type : Single Band 802.11 b/g/n, Bluetooth 5.0, ZigBee Module  
Trade Name : Redpine Signals Inc  
Model Number : M15SB  
Test Specification : FCC 47 CFR PART 15 SUBPART C  
ANSI C63.10:2013  
Receive Date : Oct. 24, 2018  
Test Period : Nov. 06~Nov. 23, 2018  
Issue Date : Dec. 17, 2018

### Issue by

A Test Lab Techno Corp.  
No. 140-1, Changan Street, Bade District,  
Taoyuan City 33465, Taiwan (R.O.C)  
Tel : +886-3-2710188 / Fax : +886-3-2710190



Taiwan Accreditation Foundation accreditation number: 1330

Test Firm MRA designation number: TW0010

**Note:** This report shall not be reproduced except in full, without the written approval of A Test Lab Techno Corp. This document may be altered or revised by A Test Lab Techno Corp. personnel only, and shall be noted in the revision section of the document. The client should not use it to claim product endorsement by TAF, or any government agencies. The test results in the report only apply to the tested sample.



### **Revision History**

Rev.	Issue Date	Revisions	Revised By
00	Dec. 05, 2018	Initial Issue	Janet Chao
01	Dec. 17, 2018	Revised Report Information	Janet Chao

## Verification of Compliance

Issued Date: Dec. 17, 2018

Applicant : Redpine Signals, Inc.  
Product Type : Single Band 802.11 b/g/n, Bluetooth 5.0, ZigBee Module  
Trade Name : Redpine Signals Inc  
Model Number : M15SB  
FCC ID : XF6-M15SB  
EUT Rated Voltage : DC 1.8 V 0.4 A/ DC 3.3 V 0.4 A  
Test Voltage : DC 3.3 V  
Applicable Standard : FCC 47 CFR PART 15 SUBPART C  
ANSI C63.10:2013  
Test Result : Complied

Performing Lab. : A Test Lab Techno Corp.  
No. 140-1, Changan Street, Bade District,  
Taoyuan City 33465, Taiwan (R.O.C)  
Tel : +886-3-2710188 / Fax : +886-3-2710190  
Taiwan Accreditation Foundation accreditation number: 1330  
<http://www.atl-lab.com.tw/e-index.htm>



A Test Lab Techno Corp. tested the above equipment in accordance with the requirements set forth in the above standards. All indications of Pass/Fail in this report are opinions expressed by A Test Lab Techno Corp. based on interpretations and/or observations of test results. The test results show that the equipment tested is capable of demonstrating compliance with the requirements as documented in this report.

Approved By : Fly Lu Reviewed By : Eric Ou Yang  
(Manager) (Fly Lu) (Testing Engineer) (Eric Ou Yang)

## TABLE OF CONTENTS

<b>1</b>	<b>General Information .....</b>	<b>5</b>
	1.1. Summary of Test Result .....	5
	1.2. Measurement Uncertainty .....	6
<b>2</b>	<b>EUT Description .....</b>	<b>7</b>
<b>3</b>	<b>Test Methodology .....</b>	<b>8</b>
	3.1. Mode of Operation.....	8
	3.2. EUT Test Step .....	9
	3.3. Configuration of Test System Details.....	10
	3.4. Test Instruments .....	11
	3.5. Test Site Environment .....	12
<b>4</b>	<b>Measurement Procedure .....</b>	<b>13</b>
	4.1. Maximum Conducted Output Power Measurement .....	13
	4.2. Radiated Emission Measurement .....	14
	4.3. 20 dB RF Bandwidth Measurement .....	17
	4.4. Carrier Frequency Separation Measurement .....	18
	4.5. Number of Hopping Measurement .....	19
	4.6. Time of Occupancy (Dwell Time) Measurement.....	20
	4.7. Out of Band Conducted Emissions Measurement .....	21
	4.8. Antenna Measurement.....	21
<b>5</b>	<b>Test Results .....</b>	<b>22</b>
	Annex A. Conducted Test Results .....	22
	Annex B. Radiated Emission Measurement.....	41



# 1 General Information

## 1.1. Summary of Test Result

Standard	Item	Result	Remark
FCC			
15.207	AC Power Conducted Emission	N/A	The device uses DC power source.
15.203	Antenna Requirement	PASS	-----
15.247(b)(1)	Max. Output Power	PASS	-----
15.247(d)	Transmitter Radiated Emissions	PASS	-----
15.247(a)(1)	20 dB RF Bandwidth	PASS	-----
15.247(a)(1)	Carrier Frequency Separation	PASS	-----
15.247(a)(1)(iii)	Number of Hopping	PASS	-----
15.247(a)(1)(iii)	Time of Occupancy (Dwell Time)	PASS	-----
15.247(d)	Out of Band Conducted Spurious Emission	PASS	-----

The test results of this report relate only to the tested sample(s) identified in this report.

Standard	Description
CFR47, Part 15, Subpart C	Intentional Radiators
ANSI C63. 10: 2013	American National Standard of Procedures for Compliance Testing of Unlicensed Wireless Devices
DA 00-705	Filing and Measurement Guidelines for Frequency Hopping Spread Spectrum Systems

## 1.2. Measurement Uncertainty

Test Item	Frequency Range	Uncertainty (dB)
Conducted Emission	9 kHz ~ 150 kHz	2.7
	150 kHz ~ 30 MHz	2.7
Radiated Emission	9 kHz ~ 30 MHz	1.7
	30 MHz ~ 1000 MHz	5.7
	1000 MHz ~ 18000 MHz	5.5
	18000 MHz ~ 26500 MHz	4.8
	26500 MHz ~ 40000 MHz	4.8
Conducted Output Power	+0.27 dB / -0.28 dB	
RF Bandwidth	4.96 %	
Power Spectral Density	+0.71 dB / -0.77 dB	



## 2 EUT Description

Applicant	Redpine Signals, Inc. 2107 N.First Street, Suite 680, San Jose, California, 95131-2019, United States			
Manufacturer	Redpine Signals, Inc. 2107 N.First Street, Suite 680, San Jose, California, 95131-2019, United States			
Product	Single Band 802.11 b/g/n, Bluetooth 5.0, ZigBee Module			
Trade Name	Redpine Signals Inc			
Model Number	M15SB			
FCC ID	XF6-M15SB			
Frequency Range	2402 ~ 2480 MHz			
Modulation Type	GFSK for 1 Mbps			
	$\pi/4$ -DQPSK for 2 Mbps			
	8DPSK for 3 Mbps			
Operate Temp. Range	-40 ~ +85 °C			
Antenna information	Model	Type	Connector	Max. Gain (dBi)
	RSIA15	PCB Trace Antenna	Internal	0.99
	WS.01.B.305151	Heavy Duty Screw Mount Antenna	SMA Reverse	4.10
RF Output Power (Conducted)	GFSK for 1 Mbps	0.05383	W	
	$\pi/4$ -DQPSK for 2 Mbps	0.07603	W	
	8DPSK for 3 Mbps	0.07798	W	

### 3 Test Methodology

#### 3.1. Mode of Operation

Decision of Test ATL has verified the construction and function in typical operation. All the test modes were carried out with the EUT in normal operation, which was shown in this test report and defined as:

Pre-Test Mode
Mode 1: Transmit mode
Mode 2: GFSK Continuous TX mode
Mode 3: $\pi/4$ -DQPSK Continuous TX mode
Mode 4: 8DPSK Continuous TX mode

After verification, all tests were carried out with the worst case test modes.

By preliminary testing and verifying three axis (X, Y and Z) position of EUT transmitted status, it was found that "X axis" position was the worst, then the final test was executed the worst condition and test data were recorded in this report.

Final-Test Mode
Mode 1: Transmit mode
Mode 2: GFSK Continuous TX mode
Mode 4: 8DPSK Continuous TX mode

#### Description of Test Modes

Preliminary tests were performed in different modulation to find the worst case. The modulation has shown the worst-case in Maximum Conducted Output Power Measurement. Investigation has been done on all the possible configurations for searching the worst cases.





### 3.2. EUT Test Step

1	Setup the EUT shown on "Configuration of Test System Details."
2	Turn on the power of all equipment.
3	Turn on TX function
4	EUT run test program.

Measurement Software			
No.	Description	Software	Version
1	Radiated Emission	EZ EMC	1.1.4.4

### 3.3. Configuration of Test System Details

Radiated Emissions\_ PCB Trace Antenna

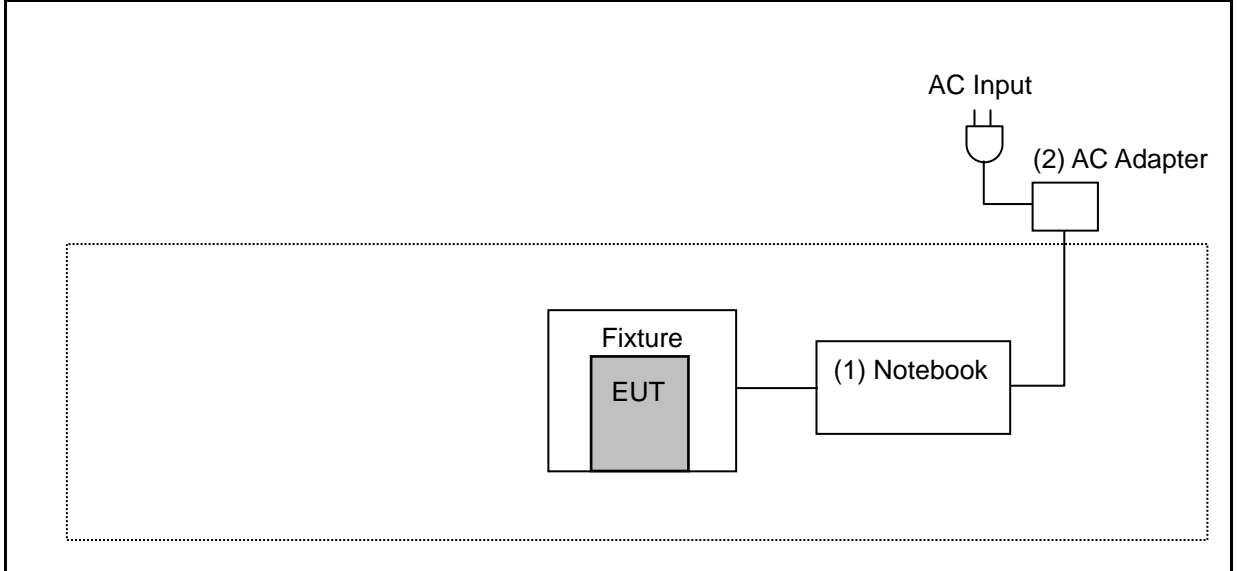

Radiated Emissions\_ Heavy Duty Screw Mount Antenna

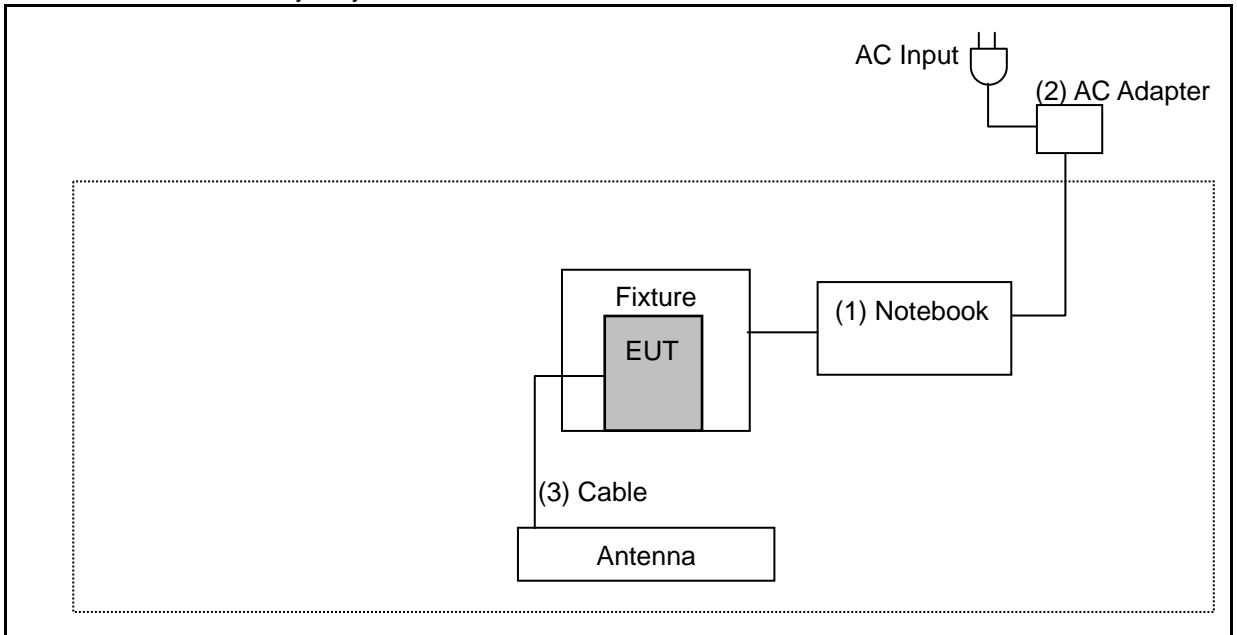

Devices Description						
	Product	Manufacturer	Model Number	Serial Number	Power Cord	Loss
(1)	Notebook	DELL	Inspiron 15	726RWN2	---	---
(2)	AC Adapter	DELL	LA65NS2-01	---	Non-Shielded, 0.8 m	---
(3)	Cable	Amphenol RF	336314-12-0100	---	---	0.38 dB



### 3.4. Test Instruments

For Radiated Emissions

Test Period: Nov. 06~Nov. 23, 2018

Equipment	Manufacturer	Model Number	Serial Number	Cal. Date	Cal. Period
Spectrum Analyzer (10 Hz~44 GHz)	Keysight	N9010A	MY52221312	01/15/2018	1 year
Pre Amplifier (1~26.5 GHz)	Agilent	8449B	3008A02237	10/19/2018	1 year
Pre Amplifier (100 kHz~1.3 GHz)	Agilent	8447D	2944A11119	01/10/2018	1 year
Trilog Broadband Antenna	SCHWARZBECK MESS-ELEKTRONIK	SB AC VULB	9168-0841	03/02/2018	1 year
Horn Antenna (1~18 GHz)	SCHWARZBECK MESS-ELEKTRONIK	BBHA9120D	9120D-550	08/23/2018	1 year
Loop Antenna	COM-POWER CORPORATION	AL-130	121014	03/13/2018	1 year
RF Cable	EMCI	EMC104-N-N-6000	TE01-1	02/20/2018	1 year
Microwave Cable	EMCI	EMC102-KM-KM- 14000	151001	02/20/2018	1 year
Broadband Horn Antenna	SCHWARZBECK MESS-ELEKTRONIK	9170	9170-320	08/07/2018	1 year

Note: N.C.R. = No Calibration Request.



For Conducted

Test Period: Nov. 08, 2018

Equipment	Manufacturer	Model Number	Serial Number	Cal. Date	Cal. Period
Power Sensor	Anritsu	MA2411B	1126022	08/29/2018	1 year
Power Meter	Anritsu	ML2495A	1135009	08/29/2018	1 year
Spectrum Analyzer (3 Hz~50 GHz)	Agilent	N9030A	MY53120541	01/02/2018	1 year
Microwave Cable	EMCI	EMC102-SM-SM15 00	001	11/22/2017	1 year

Note: N.C.R. = No Calibration Request.

### 3.5. Test Site Environment

Items	Required (IEC 60068-1)	Actual
Temperature (°C)	15-35	26
Humidity (%RH)	25-75	60
Barometric pressure (mbar)	860-1060	990

## 4 Measurement Procedure

### 4.1. Maximum Conducted Output Power Measurement

#### ■ Limit

For frequency hopping systems operating in the 2400–2483.5 MHz band employing at least 75 non-overlapping hopping channels < 0.125 watt.

#### ■ Test Setup

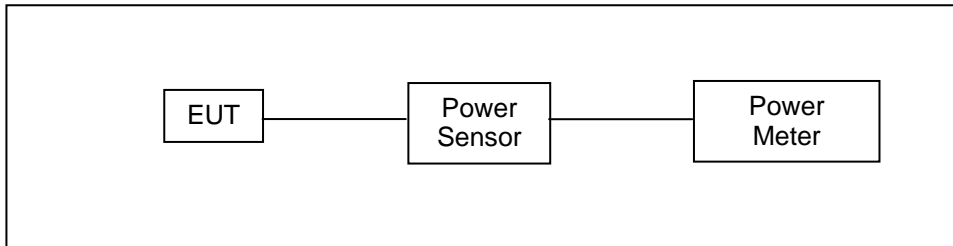

#### ■ Test Procedure

Testing must be done according to this procedure, FCC Public Notice DA 00-705 - Filing and Measurement Guidelines for Frequency Hopping Spread Spectrum Systems. This is the only method recognized by the FCC. The tests below are run with the EUT's transmitter set at high power in TX mode. The EUT is needed to force selection of output power level and channel number. While testing, EUT was set to transmit continuously. Remove the Subjective device's antenna and connect the RF output port to power sensor. The maximum peak output power shall not exceed 1 watt.

Use a direct connection between the antenna port of transmitter and the power sensor, for prevent the power sensor input attenuation 40-50 dB. Set the RBW Bandwidth of the emission or use a channel power meter mode. For antennas with gains of 6 dBi or less, maximum allowed transmitter output is 1 watt (+30 dBm). For antennas with gains greater than 6 dBi, transmitter output level must be decreased by an amount equal to  $(\text{GAIN} - 6)/3$  dBm. The antenna port of the EUT was connected to the input of a power sensor. Power was read directly and cable loss correction was added to the reading to obtain power at the EUT antenna terminals.

## 4.2. Radiated Emission Measurement

### ■ Limit

According to §15.209(a), except as provided elsewhere in this subpart, the emissions from an intentional radiator shall not exceed the field strength levels specified in the following table:

Frequency (MHz)	Field Strength ( $\mu\text{V}/\text{m}$ at meter)	Measurement Distance (meters)
0.009 – 0.490	$2400 / F$ (kHz)	300
0.490 – 1.705	$24000 / F$ (kHz)	30
1.705 – 30.0	30	30
30 - 88	$100^{**}$	3
88-216	$150^{**}$	3
216-960	$200^{**}$	3
Above 960	500	3

\*\* Except as provided in paragraph (g), fundamental emissions from intentional radiators operating under this Section shall not be located in the frequency bands 54-72 MHz, 76-88 MHz, 174-216 MHz or 470-806 MHz. However, operation within these frequency bands is permitted under other sections of this Part, e.g., Sections 15.231 and 15.241.

### ■ Setup

9 kHz ~ 30 MHz

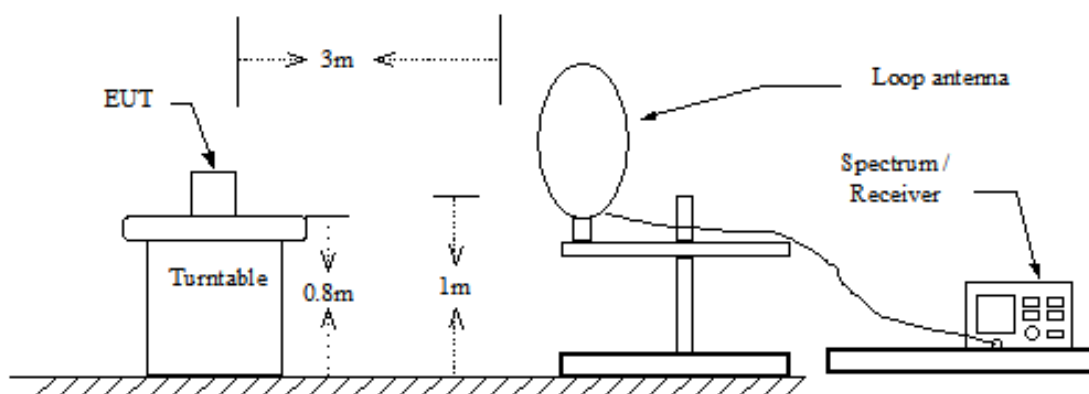

Below 1 GHz

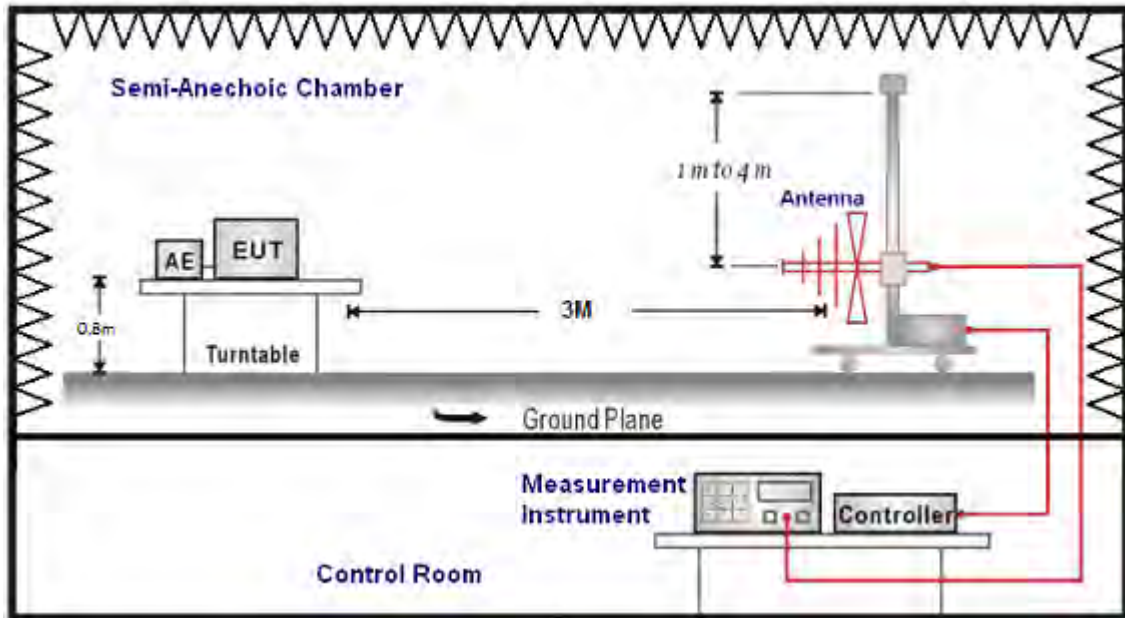

Above 1 GHz

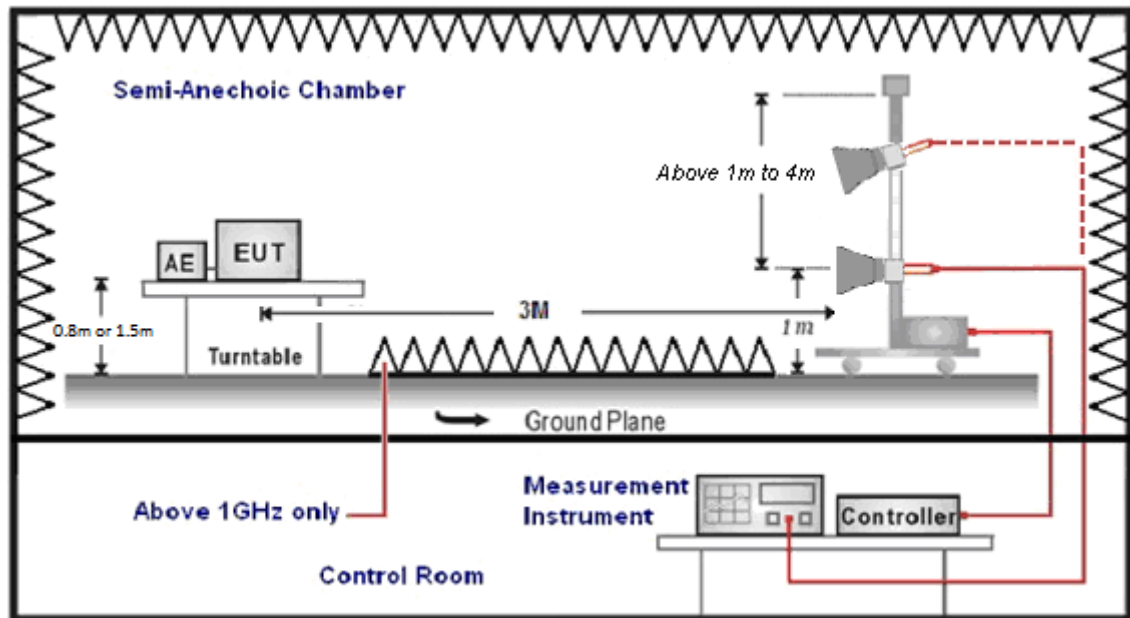



## ■ Test Procedure

Final radiation measurements were made on a three-meter, Semi Anechoic Chamber. The EUT system was placed on a nonconductive turntable which is 0.8 or 1.5 meters height, top surface 1.0 x 1.5 meter. The spectrum was examined from 250 MHz to 2.5 GHz in order to cover the whole spectrum below 10th harmonic which could generate from the EUT. During the test, EUT was set to transmit continuously & Measurements spectrum range from 9 kHz to 26.5 GHz is investigated.

For measurements below 1 GHz the resolution bandwidth is set to 100 kHz for peak detection measurements or 120 kHz for quasi-peak detection measurements. Peak detection is used unless otherwise noted as quasi-peak.

For measurements above 1 GHz the resolution bandwidth is set to 1 MHz, and then the video bandwidth is set to 3 MHz for peak measurements and 10 Hz for average measurements when Duty cycle >98 % / 1/T for average measurements when Duty cycle <98 %. A nonconductive material surrounded the EUT to supporting the EUT for standing on three orthogonal planes. At each condition, the EUT was rotated 360 degrees, and the antenna was raised and lowered from one to four meters to find the maximum emission levels. Measurements were taken using both horizontal and vertical antenna polarization.

SCHWARZBECK MESS-ELEKTRONIK Biconilog Antenna at 3 Meter and the SCHWARZBECK Double Ridged Guide Antenna was used in frequencies 1 – 26.5 GHz at a distance of 1 meter. All test results were extrapolated to equivalent signal at 3 meters utilizing an inverse linear distance extrapolation Factor (20 dB/decade).

For testing above 1 GHz, the emission level of the EUT in peak mode was 20 dB lower than average limit (that means the emission level in peak mode also complies with the limit in average mode), then testing will be stopped and peak values of EUT will be reported, otherwise, the emissions will be measured in average mode again and reported.

Appropriate preamplifiers were used for improving sensitivity and precautions were taken to avoid overloading or desensitizing the spectrum analyzer. No post – detector video filters were used in the test.

The spectrum analyzer's 6 dB bandwidth was set to 1 MHz, and the analyzer was operated in the peak detection mode, for frequencies both below and up 1 GHz. The average levels were obtained by subtracting the duty cycle correction factor from the peak readings.

The following procedures were used to convert the emission levels measured in decibels referenced to 1 microvolt (dBuV) into field intensity in micro volts per meter (uV/m).

The actual field intensity in decibels referenced to 1 microvolt in to field intensity in micro volts per meter (dBuV/m).

The actual field intensity in decibels referenced to 1 microvolt per meter (dBuV/m) is determined by algebraically adding the measured reading in dBuV, the antenna factor (dB), and cable loss (dB) and Subtracting the gain of preamplifier (dB) is auto calculate in spectrum analyzer.

$$(1) \text{ Amplitude (dBuV/m) = FI (dBuV) +AF (dBuV) +CL (dBuV)-Gain (dB)}$$

FI= Reading of the field intensity.

AF= Antenna factor.

CL= Cable loss.

P.S Amplitude is auto calculate in spectrum analyzer.

$$(2) \text{ Actual Amplitude (dBuV/m) = Amplitude (dBuV)-Dis(dB)}$$

The FCC specified emission limits were calculated according the EUT operating frequency and by following linear interpolation equations:

(a) For fundamental frequency : Transmitter Output < +30 dBm

(b) For spurious frequency : Spurious emission limits = fundamental emission limit /10

Data of measurement within this frequency range without mark in the table above means the reading of emissions are attenuated more than 20 dB below the permissible limits or the field strength is too small to be measured.



### 4.3. 20 dB RF Bandwidth Measurement

■ **Limit**

N/A

■ **Test Setup**

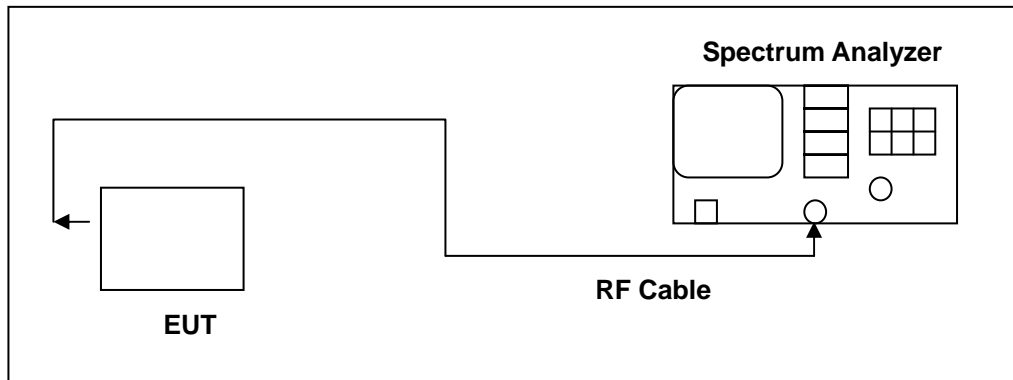

■ **Test Procedure**

Testing must be done according to this procedure, FCC Public Notice DA 00-705 - Filing and Measurement Guidelines for Frequency Hopping Spread Spectrum Systems. This is the only method recognized by the FCC. The RF output port of the Equipment-Under-Test is directly coupled to the input of the EMC analyzer through a specialized RF connector and a 10 dB passive attenuator. A fully charged battery was used for the supply voltage. The Bluetooth frequency hopping function of the EUT was enabled. The spectrum analyzer used the following settings:

1. Span = approx. 2 to 3 times the 20 dB bandwidth, centered on a hopping frequency
2. RBW  $\geq$  1 % of the 20 dB span
3. VBW  $\geq$  RBW
4. Sweep = auto
5. Detector function = peak
6. Trace = max hold

The trace was allowed to stabilize. The EUT was transmitting at its maximum data rate. The marker-to-peak function was used to set the marker to the peak of the emission. The marker-delta function was used to measure 20 dB down one side of the emission. The marker-delta function and marker was moved to the other side of the emission until it was even with the reference marker. The marker-delta reading at this point was the 20 dB bandwidth of the emission.

#### 4.4. Carrier Frequency Separation Measurement

##### ■ Limit

Title 47 of the CFR, Part 15 Subpart (c) 15.247(a)(1) requires the measurement of the bandwidth of the transmission between the -20 dB points on the transmitted spectrum. The results of this test determine the limits for channel spacing. The channel spacing shall be a minimum of 25 kHz or the 20 dB bandwidth, whichever is greater. Alternatively, frequency hopping systems operating in the 2400-2483.5 MHz band may have hopping channel carrier frequencies that are separated by 25 kHz or two-thirds of the 20 dB bandwidth of the hopping channel.

##### ■ Test Setup

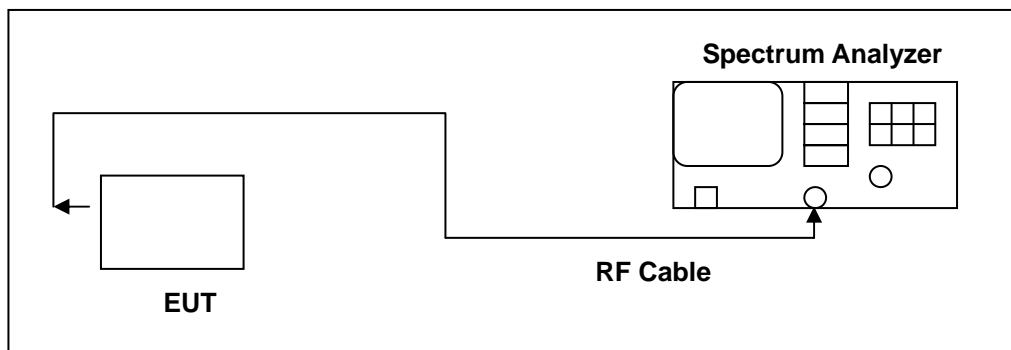

##### ■ Test Procedure

Testing must be done according to this procedure, FCC Public Notice DA 00-705 - Filing and Measurement Guidelines for Frequency Hopping Spread Spectrum Systems. This is the only method recognized by the FCC. The RF output port of the Equipment-Under-Test is directly coupled to the input of the EMC analyzer through a specialized RF connector and a 10 dB passive attenuator. A fully charged battery was used for the supply voltage. The Bluetooth frequency hopping function of the EUT was enabled. The following spectrum analyzer settings were used:

1. Span = wide enough to capture the peaks of two adjacent channels
2. Resolution (or IF) Bandwidth (RBW)  $\geq$  1 % of the span
3. Video (or Average) Bandwidth (VBW)  $\geq$  RBW
4. Sweep = auto
5. Detector function = peak
6. Trace = max hold

The trace was allowed to stabilize. The marker-delta function was used to determine the separation between the peaks of the adjacent channels.

## 4.5. Number of Hopping Measurement

### ■ Limit

Frequency hopping systems in the 2400–2483.5 MHz band shall use at least 15 channels.

### ■ Test Setup

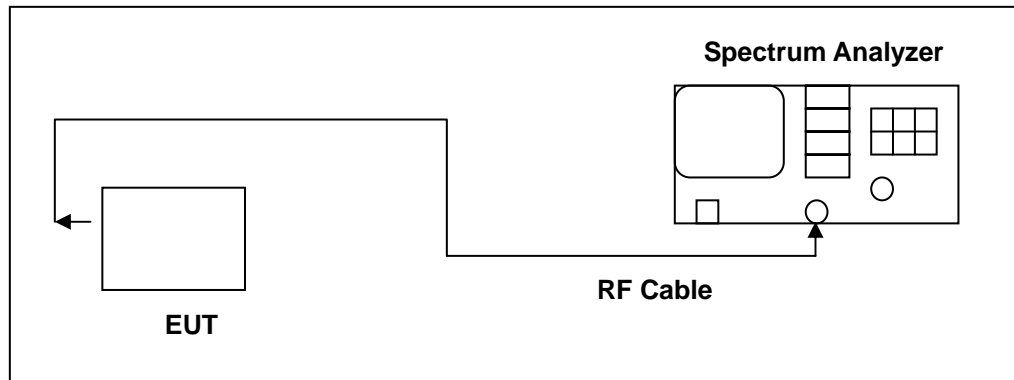

### ■ Test Procedure

Testing must be done according to this procedure, FCC Public Notice DA 00-705 - Filing and Measurement Guidelines for Frequency Hopping Spread Spectrum Systems. This is the only method recognized by the FCC. The RF output port of the Equipment-Under-Test is directly coupled to the input of the EMC analyzer through a specialized RF connector and a 10 dB passive attenuator. A fully charged battery was used for the supply voltage. The Bluetooth frequency hopping function of the EUT was enabled. The spectrum analyzer used the following settings:

1. Span = the frequency band of operation
2. RBW  $\geq$  1 % of the span
3. VBW  $\geq$  RBW
4. Sweep = auto
5. Detector function = peak
6. Trace = max hold

The trace was allowed to stabilize.

#### 4.6. Time of Occupancy (Dwell Time) Measurement

##### ■ Limit

The average time of occupancy on any channel shall not be greater than 0.4 seconds within a period of 0.4 seconds multiplied by the number of hopping channels employed.

##### ■ Test Setup

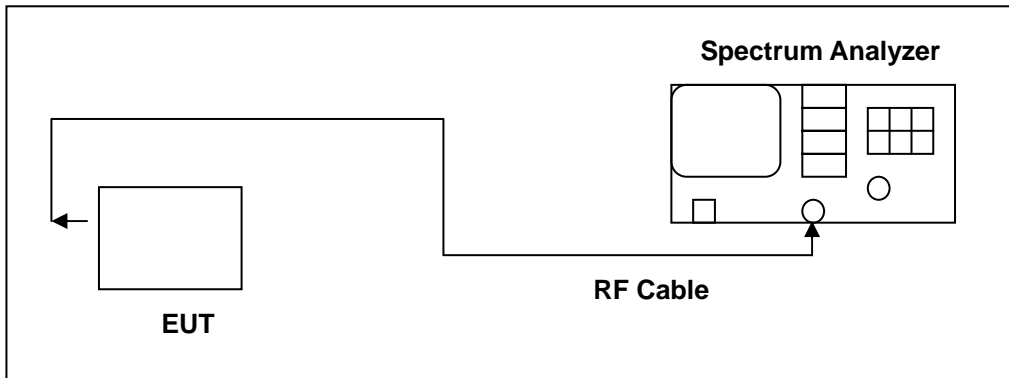

##### ■ Test Procedure

Testing must be done according to this procedure, FCC Public Notice DA 00-705 - Filing and Measurement Guidelines for Frequency Hopping Spread Spectrum Systems. This is the only method recognized by the FCC. The RF output port of the Equipment-Under-Test is directly coupled to the input of the spectrum through a specialized RF connector and a 10 dB passive attenuator. A fully charged battery was used for the supply voltage. The Bluetooth hopping function of the EUT was enabled. The following spectrum analyzer settings were used:

1. Span = zero span, centered on a hopping channel
2. RBW = 1 MHz
3. VBW  $\geq$  RBW
4. Sweep = as necessary to capture the entire dwell time per hopping channel
5. Detector function = peak
6. Trace = max hold

The marker-delta function was used to determine the dwell time.

## 4.7. Out of Band Conducted Emissions Measurement

### ■ Limit

In any 100 kHz bandwidth outside the frequency band in which the spread spectrum or digitally modulated intentional radiator is operating, the radio frequency power that is produced by the intentional radiator shall be at least 20 dB below that in the 100 kHz bandwidth within the band that contains the highest level of the desired power

### ■ Test Setup

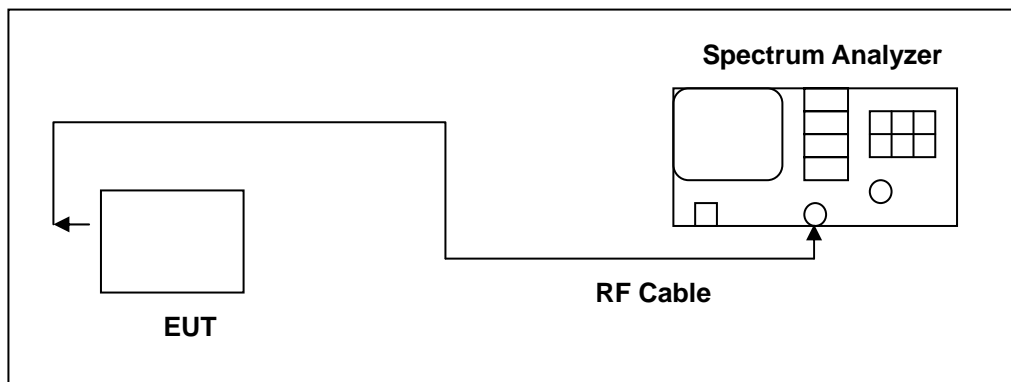

### ■ Test Procedure

Testing must be done according to this procedure, FCC Public Notice DA 00-705 - Filing and Measurement Guidelines for Frequency Hopping Spread Spectrum Systems. This is the only method recognized by the FCC. In any 100 kHz bandwidth outside the EUT pass band, the RF power produced by the modulation products of the spreading sequence, the information sequence, and the carrier frequency shall be at least 20 dB below that of the maximum in-band 100 kHz emission, antenna output of the EUT was coupled directly to spectrum analyzer; if an external attenuator and/or cable was used, these losses are compensated for with the analyzer OFFSET function. All other types of emissions from the EUT shall meet the general limits for radiated frequencies outside the pass band. The test was performed at 3 channels (Channel 0, 39, 78)

## 4.8. Antenna Measurement

### ■ Limit

For intentional device, according to 15.203, an intentional radiator shall be designed to ensure that no antenna other than that furnished by the responsible party shall be used with the device.

And According to 15.247 (b)(4), if transmitting antennas of directional gain greater than 6 dBi are used, the power shall be reduced by the amount in dB that the directional gain of the antenna exceeds 6 dBi.

### ■ Antenna Connector Construction

See section 2 – antenna information.



## 5 Test Results

### Annex A. Conducted Test Results

#### Maximum Conducted Output Power Measurement

Test Mode	Frequency (MHz)	Packet Type	RF Power setting in Test Software	Test Software Version
Mode 2	2402	DH1	20.00	Terminal
		DH3	20.00	
		DH5	20.00	
	2441	DH1	18.00	
		DH3	18.00	
		DH5	18.00	
	2480	DH1	16.00	
		DH3	16.00	
		DH5	16.00	
Mode 3	2402	2DH1	20.00	
		2DH3	20.00	
		2DH5	20.00	
	2441	2DH1	18.00	
		2DH3	18.00	
		2DH5	18.00	
	2480	2DH1	16.00	
		2DH3	16.00	
		2DH5	16.00	
Mode 4	2402	3DH1	20.00	
		3DH3	20.00	
		3DH5	20.00	
	2441	3DH1	18.00	
		3DH3	18.00	
		3DH5	18.00	
	2480	3DH1	16.00	
		3DH3	16.00	
		3DH5	16.00	



Test Mode	Frequency (MHz)	Packet Type	Average Power		Peak Power		Limit (W)
			(dBm)	(W)	(dBm)	(W)	
Mode 2	2402	DH1	15.59	0.03622	17.04	0.05058	≤ 0.125
		DH3	15.60	0.03631	17.05	0.05070	≤ 0.125
		DH5	15.62	0.03648	17.07	0.05093	≤ 0.125
	2441	DH1	15.88	0.03873	17.28	0.05346	≤ 0.125
		DH3	15.89	0.03882	17.30	0.05370	≤ 0.125
		DH5	15.91	0.03899	<b>17.31</b>	<b>0.05383</b>	≤ 0.125
	2480	DH1	14.10	0.02570	15.59	0.03622	≤ 0.125
		DH3	14.12	0.02582	15.61	0.03639	≤ 0.125
		DH5	14.13	0.02588	15.63	0.03656	≤ 0.125
Mode 3	2402	2DH1	15.00	0.03162	18.49	0.07063	≤ 0.125
		2DH3	15.01	0.03170	18.51	0.07096	≤ 0.125
		2DH5	15.03	0.03184	18.53	0.07129	≤ 0.125
	2441	2DH1	15.21	0.03319	18.79	0.07568	≤ 0.125
		2DH3	15.23	0.03334	18.80	0.07586	≤ 0.125
		2DH5	15.25	0.03350	<b>18.81</b>	<b>0.07603</b>	≤ 0.125
	2480	2DH1	13.56	0.02270	17.15	0.05188	≤ 0.125
		2DH3	13.58	0.02280	17.17	0.05212	≤ 0.125
		2DH5	13.60	0.02291	17.18	0.05224	≤ 0.125
Mode 4	2402	3DH1	15.08	0.03221	18.65	0.07328	≤ 0.125
		3DH3	15.10	0.03236	18.66	0.07345	≤ 0.125
		3DH5	15.13	0.03258	18.68	0.07379	≤ 0.125
	2441	3DH1	15.23	0.03334	18.88	0.07727	≤ 0.125
		3DH3	15.25	0.03350	18.90	0.07762	≤ 0.125
		3DH5	15.27	0.03365	<b>18.92</b>	<b>0.07798</b>	≤ 0.125
	2480	3DH1	13.59	0.02286	17.28	0.05346	≤ 0.125
		3DH3	13.61	0.02296	17.29	0.05358	≤ 0.125
		3DH5	13.62	0.02301	17.31	0.05383	≤ 0.125

Note: The relevant measured result has the offset with cable loss already.



**20 dB RF Bandwidth Measurement**

Test Mode	Frequency (MHz)	Measurement Results (MHz)
Mode 2	2402	1.045
	2441	1.049
	2480	1.028
Mode 4	2402	1.316
	2441	1.284
	2480	1.281



■ Test Graphs

Mode 2: GFSK Continuous TX mode	
2402 MHz	<p>Agilent Spectrum Analyzer - Occupied BW</p> <p>Center Freq: 2.40200000 GHz          Trig: Free Run          #Att: 20 dB          Radio Std: None          Radio Device: BTS</p> <p>Ref 30.00 dBm</p> <p>Center 2.402 GHz          #Res BW 30 kHz          VBW 300 kHz          Span 3 MHz          Sweep 3.133 ms</p> <p>Occupied Bandwidth <b>951.48 kHz</b>          Total Power 25.3 dBm</p> <p>Transmit Freq Error -8.475 kHz          OBW Power 99.00 %          x dB Bandwidth 1.045 MHz x dB -20.00 dB</p>
2441 MHz	<p>Agilent Spectrum Analyzer - Occupied BW</p> <p>Center Freq: 2.44100000 GHz          Trig: Free Run          #Att: 20 dB          Radio Std: None          Radio Device: BTS</p> <p>Ref 30.00 dBm</p> <p>Center 2.441 GHz          #Res BW 30 kHz          VBW 300 kHz          Span 3 MHz          Sweep 3.133 ms</p> <p>Occupied Bandwidth <b>952.44 kHz</b>          Total Power 25.3 dBm</p> <p>Transmit Freq Error -11.609 kHz          OBW Power 99.00 %          x dB Bandwidth 1.049 MHz x dB -20.00 dB</p>
2480 MHz	<p>Agilent Spectrum Analyzer - Occupied BW</p> <p>Center Freq: 2.48000000 GHz          Trig: Free Run          #Att: 20 dB          Radio Std: None          Radio Device: BTS</p> <p>Ref 30.00 dBm</p> <p>Center 2.48 GHz          #Res BW 30 kHz          VBW 300 kHz          Span 3 MHz          Sweep 3.133 ms</p> <p>Occupied Bandwidth <b>947.18 kHz</b>          Total Power 23.3 dBm</p> <p>Transmit Freq Error -19.920 kHz          OBW Power 99.00 %          x dB Bandwidth 1.028 MHz x dB -20.00 dB</p>

Mode 4: 8DPSK Continuous TX mode	
2402 MHz	<p>Agilent Spectrum Analyzer - Occupied BW</p> <p>Center Freq: 2.40200000 GHz Trig: Free Run #Atten: 20 dB Avg/Hold: 10/10 Radio Std: None Radio Device: BTS</p> <p>Ref 30.00 dBm</p> <p>Center 2.402 GHz #Res BW 30 kHz Span 3 MHz Sweep 3.133 ms VBW 300 kHz</p> <p>Occupied Bandwidth <b>1.1894 MHz</b> Total Power 26.0 dBm</p> <p>Transmit Freq Error -19.933 kHz OBW Power 99.00 % x dB Bandwidth 1.316 MHz x dB -20.00 dB</p>
2441 MHz	<p>Agilent Spectrum Analyzer - Occupied BW</p> <p>Center Freq: 2.441000000 GHz Trig: Free Run #Atten: 20 dB Avg/Hold: 10/10 Radio Std: None Radio Device: BTS</p> <p>Ref 30.00 dBm</p> <p>Center 2.441 GHz #Res BW 30 kHz Span 3 MHz Sweep 3.133 ms VBW 300 kHz</p> <p>Occupied Bandwidth <b>1.1760 MHz</b> Total Power 26.0 dBm</p> <p>Transmit Freq Error -22.675 kHz OBW Power 99.00 % x dB Bandwidth 1.284 MHz x dB -20.00 dB</p>
2480 MHz	<p>Agilent Spectrum Analyzer - Occupied BW</p> <p>Center Freq: 2.480000000 GHz Trig: Free Run #Atten: 20 dB Avg/Hold: 10/10 Radio Std: None Radio Device: BTS</p> <p>Ref 30.00 dBm</p> <p>Center 2.48 GHz #Res BW 30 kHz Span 3 MHz Sweep 3.133 ms VBW 300 kHz</p> <p>Occupied Bandwidth <b>1.1759 MHz</b> Total Power 24.2 dBm</p> <p>Transmit Freq Error -23.972 kHz OBW Power 99.00 % x dB Bandwidth 1.281 MHz x dB -20.00 dB</p>



**Carrier Frequency Separation Measurement**

Test Mode	Frequency (MHz)	Measurement Results (MHz)	Limit (MHz)
Mode 2	2402	1.000	≥ 0.697
	2441	1.000	≥ 0.699
	2480	1.000	≥ 0.685
Mode 4	2402	1.000	≥ 0.877
	2441	1.000	≥ 0.856
	2480	1.000	≥ 0.854



■ Test Graphs

Mode 2: GFSK Continuous TX mode																																					
2402 MHz	<table border="1"> <thead> <tr> <th>MAR</th> <th>MODE</th> <th>TRC</th> <th>SCL</th> <th>X1</th> <th>Y1</th> <th>FUNCTION</th> <th>FUNCTION WIDTH</th> <th>FUNCTION VALUE</th> </tr> </thead> <tbody> <tr> <td>1</td> <td>N</td> <td>1</td> <td>f</td> <td>2.401970 GHz</td> <td>15.277 dBm</td> <td></td> <td></td> <td></td> </tr> <tr> <td>2</td> <td>N</td> <td>1</td> <td>f</td> <td>2.402970 GHz</td> <td>15.746 dBm</td> <td></td> <td></td> <td></td> </tr> <tr> <td>3</td> <td>N</td> <td>1</td> <td>f</td> <td>2.403970 GHz</td> <td>15.456 dBm</td> <td></td> <td></td> <td></td> </tr> </tbody> </table>	MAR	MODE	TRC	SCL	X1	Y1	FUNCTION	FUNCTION WIDTH	FUNCTION VALUE	1	N	1	f	2.401970 GHz	15.277 dBm				2	N	1	f	2.402970 GHz	15.746 dBm				3	N	1	f	2.403970 GHz	15.456 dBm			
MAR	MODE	TRC	SCL	X1	Y1	FUNCTION	FUNCTION WIDTH	FUNCTION VALUE																													
1	N	1	f	2.401970 GHz	15.277 dBm																																
2	N	1	f	2.402970 GHz	15.746 dBm																																
3	N	1	f	2.403970 GHz	15.456 dBm																																
2441 MHz	<table border="1"> <thead> <tr> <th>MAR</th> <th>MODE</th> <th>TRC</th> <th>SCL</th> <th>X1</th> <th>Y1</th> <th>FUNCTION</th> <th>FUNCTION WIDTH</th> <th>FUNCTION VALUE</th> </tr> </thead> <tbody> <tr> <td>1</td> <td>N</td> <td>1</td> <td>f</td> <td>2.439970 GHz</td> <td>14.326 dBm</td> <td></td> <td></td> <td></td> </tr> <tr> <td>2</td> <td>N</td> <td>1</td> <td>f</td> <td>2.440970 GHz</td> <td>15.439 dBm</td> <td></td> <td></td> <td></td> </tr> <tr> <td>3</td> <td>N</td> <td>1</td> <td>f</td> <td>2.441970 GHz</td> <td>15.221 dBm</td> <td></td> <td></td> <td></td> </tr> </tbody> </table>	MAR	MODE	TRC	SCL	X1	Y1	FUNCTION	FUNCTION WIDTH	FUNCTION VALUE	1	N	1	f	2.439970 GHz	14.326 dBm				2	N	1	f	2.440970 GHz	15.439 dBm				3	N	1	f	2.441970 GHz	15.221 dBm			
MAR	MODE	TRC	SCL	X1	Y1	FUNCTION	FUNCTION WIDTH	FUNCTION VALUE																													
1	N	1	f	2.439970 GHz	14.326 dBm																																
2	N	1	f	2.440970 GHz	15.439 dBm																																
3	N	1	f	2.441970 GHz	15.221 dBm																																
2480 MHz	<table border="1"> <thead> <tr> <th>MAR</th> <th>MODE</th> <th>TRC</th> <th>SCL</th> <th>X1</th> <th>Y1</th> <th>FUNCTION</th> <th>FUNCTION WIDTH</th> <th>FUNCTION VALUE</th> </tr> </thead> <tbody> <tr> <td>1</td> <td>N</td> <td>1</td> <td>f</td> <td>2.477970 GHz</td> <td>13.723 dBm</td> <td></td> <td></td> <td></td> </tr> <tr> <td>2</td> <td>N</td> <td>1</td> <td>f</td> <td>2.478970 GHz</td> <td>13.836 dBm</td> <td></td> <td></td> <td></td> </tr> <tr> <td>3</td> <td>N</td> <td>1</td> <td>f</td> <td>2.479970 GHz</td> <td>13.763 dBm</td> <td></td> <td></td> <td></td> </tr> </tbody> </table>	MAR	MODE	TRC	SCL	X1	Y1	FUNCTION	FUNCTION WIDTH	FUNCTION VALUE	1	N	1	f	2.477970 GHz	13.723 dBm				2	N	1	f	2.478970 GHz	13.836 dBm				3	N	1	f	2.479970 GHz	13.763 dBm			
MAR	MODE	TRC	SCL	X1	Y1	FUNCTION	FUNCTION WIDTH	FUNCTION VALUE																													
1	N	1	f	2.477970 GHz	13.723 dBm																																
2	N	1	f	2.478970 GHz	13.836 dBm																																
3	N	1	f	2.479970 GHz	13.763 dBm																																

Mode 4: 8DPSK Continuous TX mode																																					
2402 MHz	<table border="1"> <thead> <tr> <th>MAR</th> <th>MODE</th> <th>TRIG</th> <th>SOL</th> <th>F</th> <th>P</th> <th>FUNCTION</th> <th>FUNCTION (MATH)</th> <th>FUNCTION VALUE</th> </tr> </thead> <tbody> <tr> <td>1</td> <td>N</td> <td>1</td> <td>f</td> <td>2.401828 GHz</td> <td>16.074 dBm</td> <td></td> <td></td> <td></td> </tr> <tr> <td>2</td> <td>N</td> <td>1</td> <td>f</td> <td>2.402828 GHz</td> <td>15.128 dBm</td> <td></td> <td></td> <td></td> </tr> <tr> <td>3</td> <td>N</td> <td>1</td> <td>f</td> <td>2.403828 GHz</td> <td>14.914 dBm</td> <td></td> <td></td> <td></td> </tr> </tbody> </table>	MAR	MODE	TRIG	SOL	F	P	FUNCTION	FUNCTION (MATH)	FUNCTION VALUE	1	N	1	f	2.401828 GHz	16.074 dBm				2	N	1	f	2.402828 GHz	15.128 dBm				3	N	1	f	2.403828 GHz	14.914 dBm			
MAR	MODE	TRIG	SOL	F	P	FUNCTION	FUNCTION (MATH)	FUNCTION VALUE																													
1	N	1	f	2.401828 GHz	16.074 dBm																																
2	N	1	f	2.402828 GHz	15.128 dBm																																
3	N	1	f	2.403828 GHz	14.914 dBm																																
2441 MHz	<table border="1"> <thead> <tr> <th>MAR</th> <th>MODE</th> <th>TRIG</th> <th>SOL</th> <th>F</th> <th>P</th> <th>FUNCTION</th> <th>FUNCTION (MATH)</th> <th>FUNCTION VALUE</th> </tr> </thead> <tbody> <tr> <td>1</td> <td>N</td> <td>1</td> <td>f</td> <td>2.439828 GHz</td> <td>16.263 dBm</td> <td></td> <td></td> <td></td> </tr> <tr> <td>2</td> <td>N</td> <td>1</td> <td>f</td> <td>2.440828 GHz</td> <td>14.875 dBm</td> <td></td> <td></td> <td></td> </tr> <tr> <td>3</td> <td>N</td> <td>1</td> <td>f</td> <td>2.441828 GHz</td> <td>14.971 dBm</td> <td></td> <td></td> <td></td> </tr> </tbody> </table>	MAR	MODE	TRIG	SOL	F	P	FUNCTION	FUNCTION (MATH)	FUNCTION VALUE	1	N	1	f	2.439828 GHz	16.263 dBm				2	N	1	f	2.440828 GHz	14.875 dBm				3	N	1	f	2.441828 GHz	14.971 dBm			
MAR	MODE	TRIG	SOL	F	P	FUNCTION	FUNCTION (MATH)	FUNCTION VALUE																													
1	N	1	f	2.439828 GHz	16.263 dBm																																
2	N	1	f	2.440828 GHz	14.875 dBm																																
3	N	1	f	2.441828 GHz	14.971 dBm																																
2480 MHz	<table border="1"> <thead> <tr> <th>MAR</th> <th>MODE</th> <th>TRIG</th> <th>SOL</th> <th>F</th> <th>P</th> <th>FUNCTION</th> <th>FUNCTION (MATH)</th> <th>FUNCTION VALUE</th> </tr> </thead> <tbody> <tr> <td>1</td> <td>N</td> <td>1</td> <td>f</td> <td>2.477828 GHz</td> <td>13.398 dBm</td> <td></td> <td></td> <td></td> </tr> <tr> <td>2</td> <td>N</td> <td>1</td> <td>f</td> <td>2.478828 GHz</td> <td>13.167 dBm</td> <td></td> <td></td> <td></td> </tr> <tr> <td>3</td> <td>N</td> <td>1</td> <td>f</td> <td>2.479828 GHz</td> <td>13.567 dBm</td> <td></td> <td></td> <td></td> </tr> </tbody> </table>	MAR	MODE	TRIG	SOL	F	P	FUNCTION	FUNCTION (MATH)	FUNCTION VALUE	1	N	1	f	2.477828 GHz	13.398 dBm				2	N	1	f	2.478828 GHz	13.167 dBm				3	N	1	f	2.479828 GHz	13.567 dBm			
MAR	MODE	TRIG	SOL	F	P	FUNCTION	FUNCTION (MATH)	FUNCTION VALUE																													
1	N	1	f	2.477828 GHz	13.398 dBm																																
2	N	1	f	2.478828 GHz	13.167 dBm																																
3	N	1	f	2.479828 GHz	13.567 dBm																																



**Number of Hopping Measurement**

Test Mode	Frequency Range (MHz)	Measurement Results (Ch)	Limit (ch)
Mode 2	2402 - 2480	79	≥ 15
Mode 4	2402 - 2480	79	≥ 15

■ Test Graphs

Mode 2: GFSK Continuous TX mode	
CH0~CH39	
CH40~CH78	

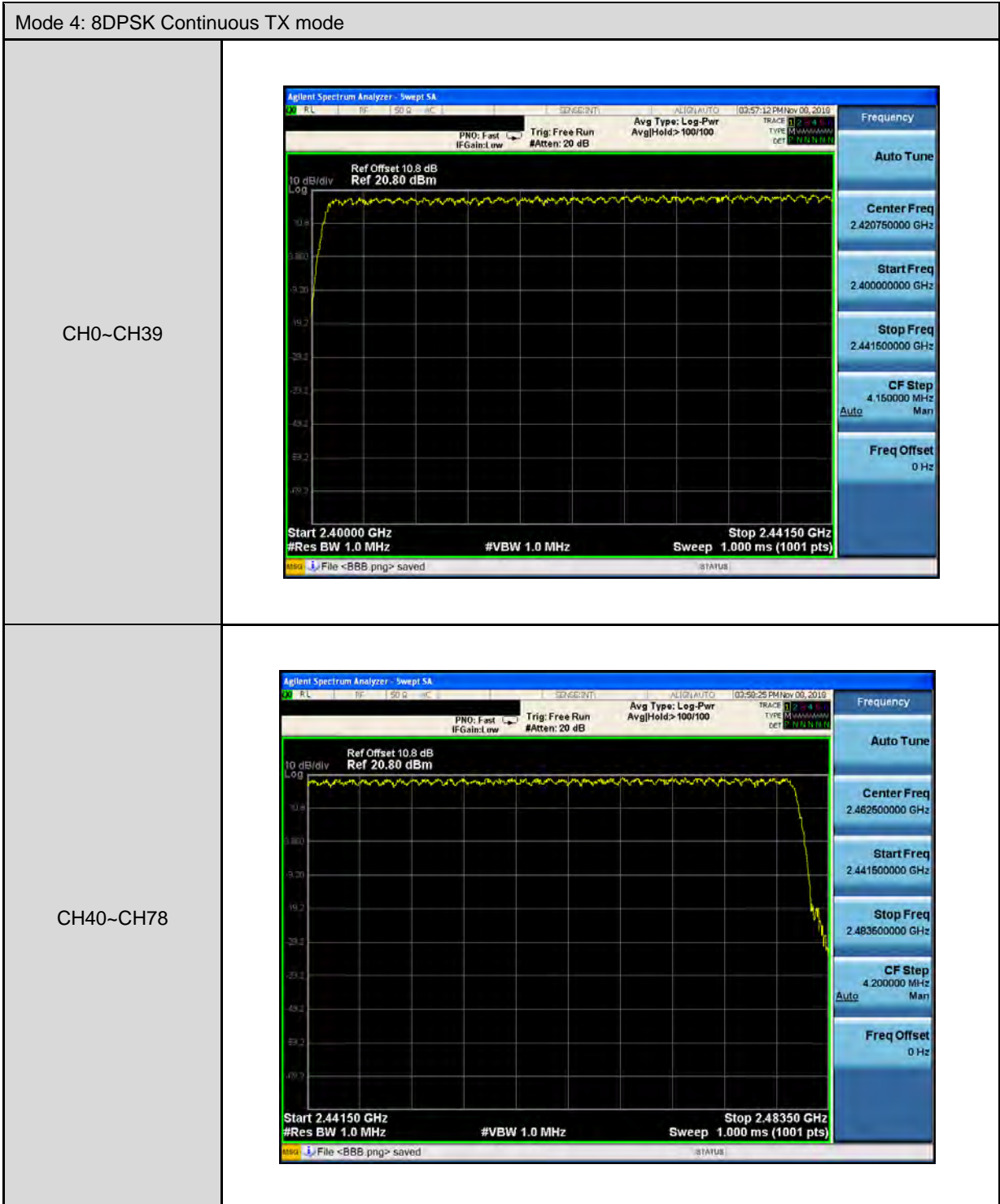





**Time of Occupancy (Dwell Time) Measurement**

Mode 2: GFSK Continuous TX mode	
DH1	
Cycle Calculate	$79CH * 0.4 = 31.6 \text{ (sec)}$
The EUT Hopping Number per Sec	1600 times/sec
Each Channel Dwell Times per Sec	$800/79CH = 10.13(\text{times/sec})$
Each Channel Dwell Times on Cycle(1)	$31.6 * 10.13 = 320.108(\text{times})$
Each Channel Dwell Times (2)	0.410 ms (sec)
Dwell Times on Cycle (1) * (2)	131.244 ms (sec)
LIMIT(msec)	$< = 400$
DH3	
Cycle Calculate	$79CH * 0.4 = 31.6 \text{ (sec)}$
The EUT Hopping Number per Sec	1600 times/sec
Each Channel Dwell Times per Sec	$400/79CH = 5.1(\text{times/sec})$
Each Channel Dwell Times on Cycle(1)	$31.6 * 5.1 = 161.16(\text{times})$
Each Channel Dwell Times (2)	1.650 ms (sec)
Dwell Times on Cycle (1) * (2)	263.828 ms (sec)
LIMIT(msec)	$< = 400$
DH5	
Cycle Calculate	$79CH * 0.4 = 31.6 \text{ (sec)}$
The EUT Hopping Number per Sec	1600 times/sec
Each Channel Dwell Times per Sec	$266.7/79CH = 3.37(\text{times/sec})$
Each Channel Dwell Times on Cycle(1)	$31.6 * 3.37 = 106.492(\text{times})$
Each Channel Dwell Times (2)	2.910 ms (sec)
Dwell Times on Cycle (1) * (2)	310.811 ms (sec)
LIMIT(msec)	$< = 400$



Mode 4: 8DPSK Continuous TX mode	
<b>3DH1</b>	
Cycle Calculate	$79CH * 0.4 = 31.6 \text{ (sec)}$
The EUT Hopping Number per Sec	1600 times/sec
Each Channel Dwell Times per Sec	$800/79CH = 10.13(\text{times/sec})$
Each Channel Dwell Times on Cycle(1)	$31.6 * 10.13 = 320.108(\text{times})$
Each Channel Dwell Times (2)	0.410 ms (sec)
Dwell Times on Cycle (1) * (2)	131.244 ms (sec)
LIMIT(msec)	< = 400
<b>3DH3</b>	
Cycle Calculate	$79CH * 0.4 = 31.6 \text{ (sec)}$
The EUT Hopping Number per Sec	1600 times/sec
Each Channel Dwell Times per Sec	$400/79CH = 5.1(\text{times/sec})$
Each Channel Dwell Times on Cycle(1)	$31.6 * 5.1 = 161.16(\text{times})$
Each Channel Dwell Times (2)	1.540 ms (sec)
Dwell Times on Cycle (1) * (2)	246.240 ms (sec)
LIMIT(msec)	< = 400
<b>3DH5</b>	
Cycle Calculate	$79CH * 0.4 = 31.6 \text{ (sec)}$
The EUT Hopping Number per Sec	1600 times/sec
Each Channel Dwell Times per Sec	$266.7/79CH = 3.37(\text{times/sec})$
Each Channel Dwell Times on Cycle(1)	$31.6 * 3.37 = 106.492(\text{times})$
Each Channel Dwell Times (2)	2.910 ms (sec)
Dwell Times on Cycle (1) * (2)	310.811 ms (sec)
LIMIT(msec)	< = 400



■ Test Graphs

Mode 2: GFSK Continuous TX mode	
DH1	
DH3	
DH5	



Mode 4: 8DPSK Continuous TX mode	
3DH1	
3DH3	
3DH5	

### Out of Band Conducted Emissions Measurement

#### ■ Test Graphs

Mode 2: GFSK Continuous TX mode	
2402 MHz	
2441 MHz	
2480 MHz	



Mode 4: 8DPSK Continuous TX mode																			
2402 MHz	<table border="1"><thead><tr><th>Mkr</th><th>Mode</th><th>Trc</th><th>Sol</th><th>X</th><th>Y</th><th>Function</th><th>Function Width</th><th>Function Value</th></tr></thead><tbody><tr><td>1</td><td>N</td><td>1</td><td>f</td><td>2402.0 GHz</td><td>16.547 dBm</td><td></td><td></td><td></td></tr></tbody></table>	Mkr	Mode	Trc	Sol	X	Y	Function	Function Width	Function Value	1	N	1	f	2402.0 GHz	16.547 dBm			
Mkr	Mode	Trc	Sol	X	Y	Function	Function Width	Function Value											
1	N	1	f	2402.0 GHz	16.547 dBm														
2441 MHz	<table border="1"><thead><tr><th>Mkr</th><th>Mode</th><th>Trc</th><th>Sol</th><th>X</th><th>Y</th><th>Function</th><th>Function Width</th><th>Function Value</th></tr></thead><tbody><tr><td>1</td><td>N</td><td>1</td><td>f</td><td>2441.0 GHz</td><td>16.388 dBm</td><td></td><td></td><td></td></tr></tbody></table>	Mkr	Mode	Trc	Sol	X	Y	Function	Function Width	Function Value	1	N	1	f	2441.0 GHz	16.388 dBm			
Mkr	Mode	Trc	Sol	X	Y	Function	Function Width	Function Value											
1	N	1	f	2441.0 GHz	16.388 dBm														
2480 MHz	<table border="1"><thead><tr><th>Mkr</th><th>Mode</th><th>Trc</th><th>Sol</th><th>X</th><th>Y</th><th>Function</th><th>Function Width</th><th>Function Value</th></tr></thead><tbody><tr><td>1</td><td>N</td><td>1</td><td>f</td><td>2480.0 GHz</td><td>13.010 dBm</td><td></td><td></td><td></td></tr></tbody></table>	Mkr	Mode	Trc	Sol	X	Y	Function	Function Width	Function Value	1	N	1	f	2480.0 GHz	13.010 dBm			
Mkr	Mode	Trc	Sol	X	Y	Function	Function Width	Function Value											
1	N	1	f	2480.0 GHz	13.010 dBm														

Mode 2: GFSK Continuous TX mode \_ Un-hopping

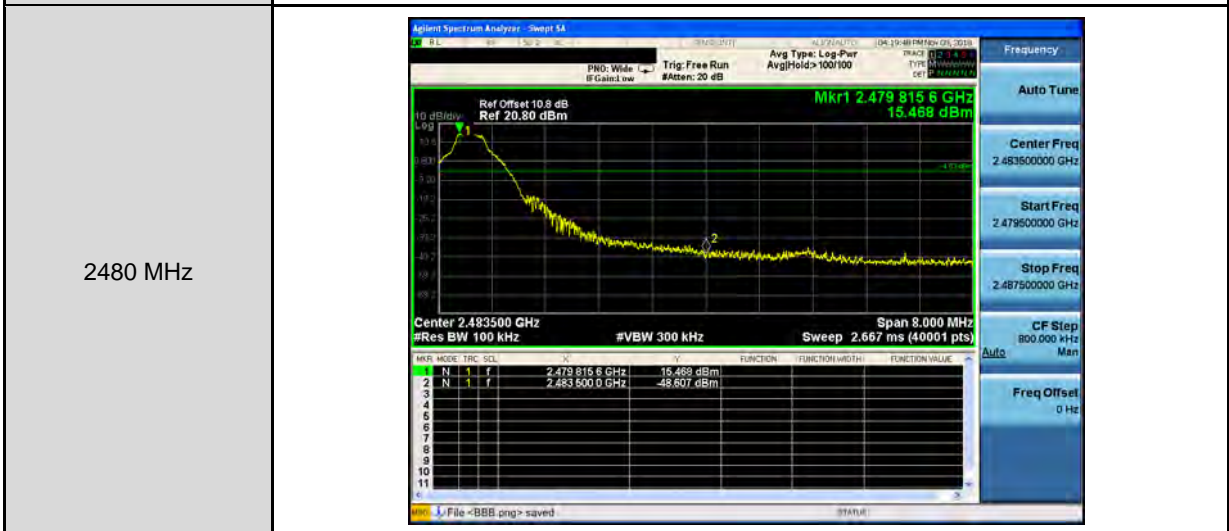

Mode 2: GFSK Continuous TX mode \_ Hopping

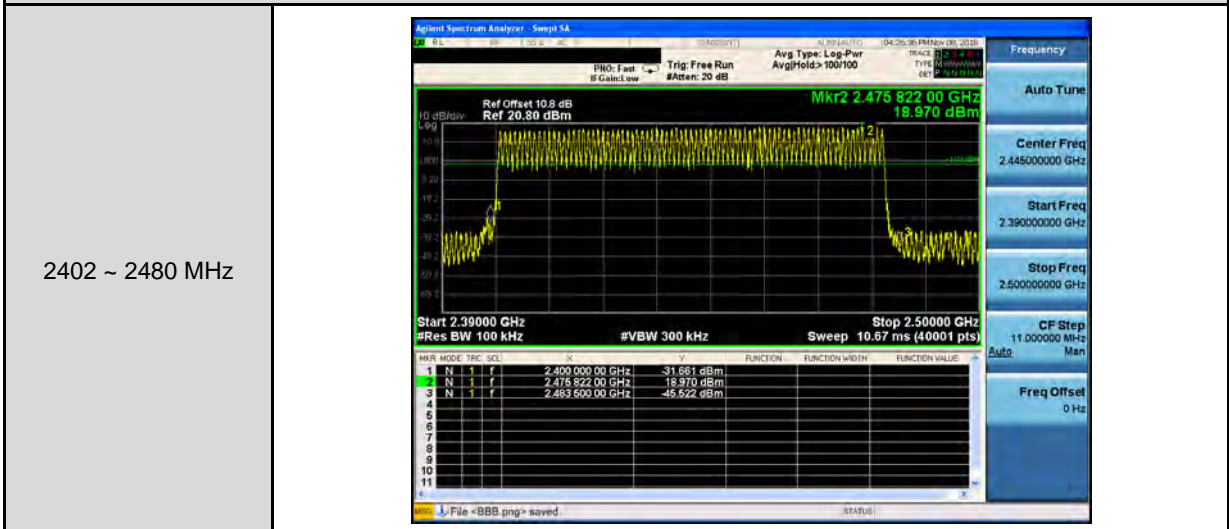

Mode 4: 8DPSK Continuous TX mode \_ Un-hopping



Mode 4: 8DPSK Continuous TX mode \_ Hopping

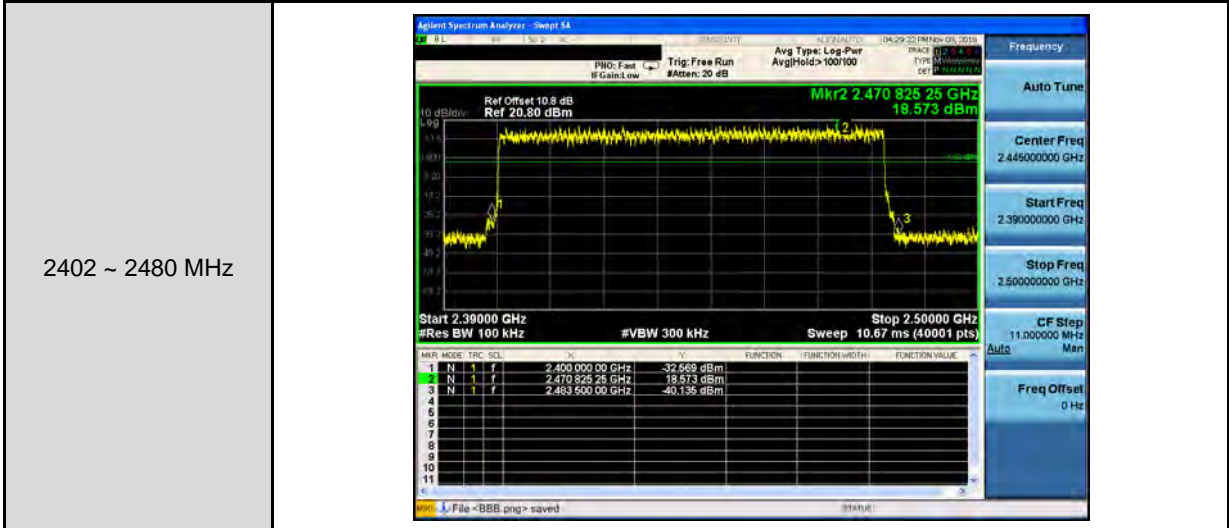





## Annex B. Radiated Emission Measurement

### Harmonic

Antenna Type: PCB Trace Antenna
---------------------------------

Below 1 GHz

Standard:	FCC Part 15.247	Test Distance:	3 m				
Test item:	Harmonic	Power:	DC 3.3 V				
Test Mode:	Mode 1	Temp.(°C)/Hum.(%RH):	26(°C)/60 %RH				
Frequency (MHz)	Reading (dBuV)	Correct Factor (dB/m)	Result (dBuV/m)	Limit (dBuV/m)	Margin (dB)	Remark	Ant.Polar. H / V
167.7400	40.15	-6.57	33.58	43.50	-9.92	QP	H
233.7000	40.12	-7.59	32.53	46.00	-13.47	QP	H
365.6200	32.45	-3.56	28.89	46.00	-17.11	QP	H
522.7600	35.05	-0.35	34.70	46.00	-11.30	QP	H
650.8000	29.01	2.16	31.17	46.00	-14.83	QP	H
845.7700	28.91	5.94	34.85	46.00	-11.15	QP	H
167.7400	35.18	-6.57	28.61	43.50	-14.89	QP	V
298.6900	32.76	-4.73	28.03	46.00	-17.97	QP	V
364.6500	29.16	-3.59	25.57	46.00	-20.43	QP	V
493.6600	32.62	-0.93	31.69	46.00	-14.31	QP	V
636.2500	28.69	1.94	30.63	46.00	-15.37	QP	V
874.8700	28.92	6.42	35.34	46.00	-10.66	QP	V

Note:1.Result (dBuV/m) = Correct Factor (dB/m) + Reading(dBuV).

Example: 33.58= -6.57+40.15

2.Correction factor (dB/m) = Antenna Factor (dB/m) + Cable loss (dB) – Pre-Amplifier gain (dB).

3. When the peak results are less than average limit, so not need to evaluate the average.



Above 1 GHz

Standard:	FCC Part 15.247	Test Distance:	3 m
Test item:	Harmonic	Power:	DC 3.3 V
Frequency:	2402 MHz	Temp.(°C)/Hum.(%RH):	26(°C)/60 %RH
Mode:	Mode 2		
Ant.Polar.:	Horizontal		

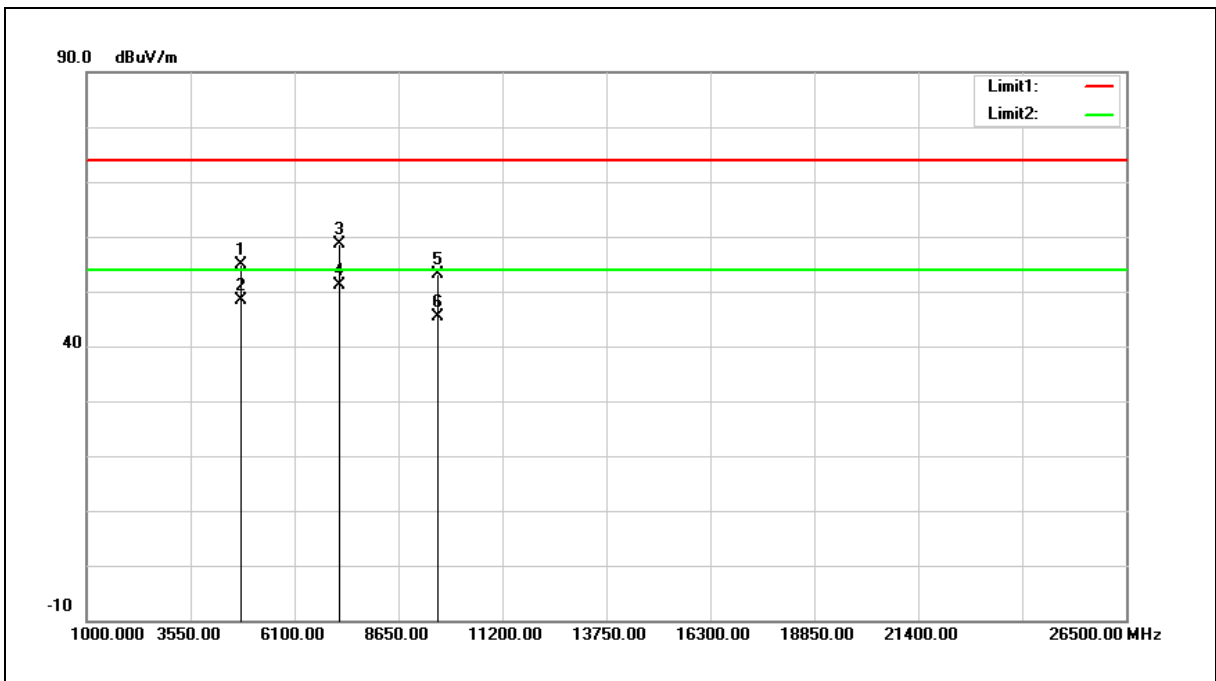

No.	Frequency (MHz)	Reading (dBuV)	Correct Factor (dB/m)	Result (dBuV/m)	Limit (dBuV/m)	Margin (dB)	Remark
1	4804.000	47.55	7.30	54.85	74.00	-19.15	peak
2	4804.000	41.17	7.30	48.47	54.00	-5.53	AVG
3	7206.000	48.58	9.95	58.53	74.00	-15.47	peak
4	7206.000	41.30	9.95	51.25	54.00	-2.75	AVG
5	9608.000	41.71	11.45	53.16	74.00	-20.84	peak
6	9608.000	33.81	11.45	45.26	54.00	-8.74	AVG

Note:1.Result (dBuV/m) = Correct Factor (dB/m) + Reading(dBuV).

Example: 54.85= 7.30+47.55

2.Correction factor (dB/m) = Antenna Factor (dB/m) + Cable loss (dB) – Pre-Amplifier gain (dB).

3.When the peak results are less than average limit, so not need to evaluate the average.

Standard:	FCC Part 15.247	Test Distance:	3 m
Test item:	Harmonic	Power:	DC 3.3 V
Frequency:	2402 MHz	Temp.(°C)/Hum.(%RH):	26(°C)/60 %RH
Mode:	Mode 2		
Ant.Polar.:	Vertical		

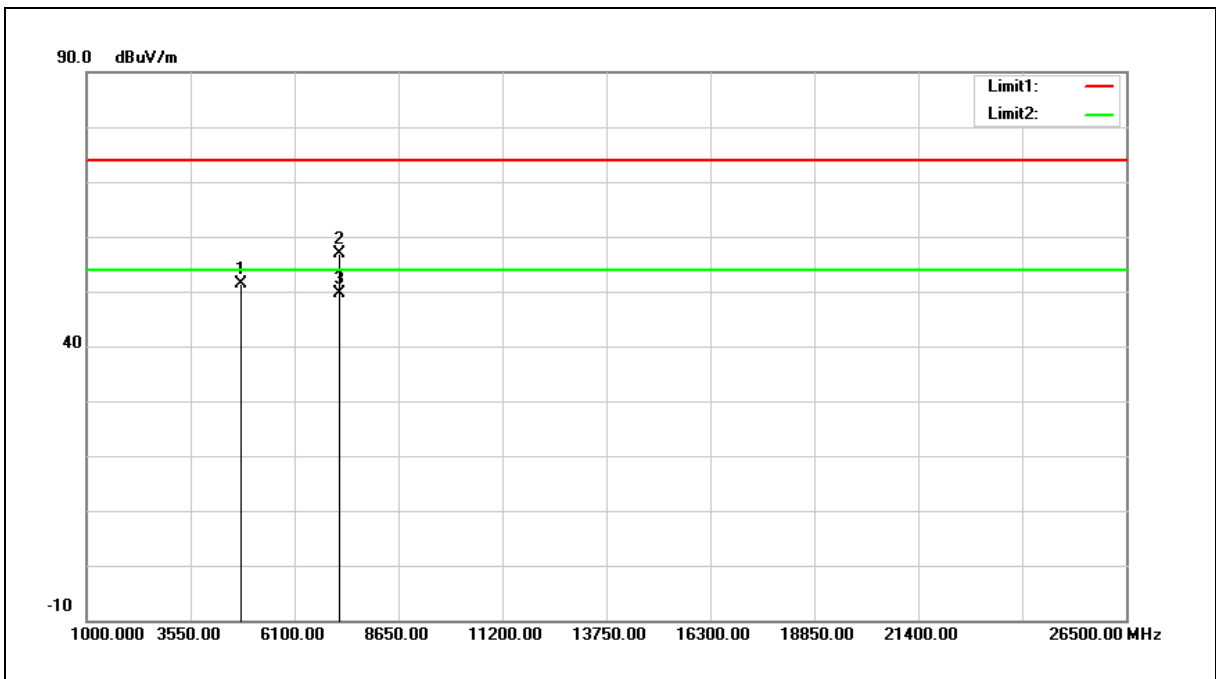

No.	Frequency (MHz)	Reading (dBuV)	Correct Factor (dB/m)	Result (dBuV/m)	Limit (dBuV/m)	Margin (dB)	Remark
1	4804.000	44.17	7.30	51.47	74.00	-22.53	peak
2	7206.000	46.90	9.95	56.85	74.00	-17.15	peak
3	7206.000	39.66	9.95	49.61	54.00	-4.39	AVG

Note:1.Result (dBuV/m) = Correct Factor (dB/m) + Reading(dBuV).

2.Correction factor (dB/m) = Antenna Factor (dB/m) + Cable loss (dB) – Pre-Amplifier gain (dB).

3.When the peak results are less than average limit, so not need to evaluate the average.



Standard:	FCC Part 15.247	Test Distance:	3 m
Test item:	Harmonic	Power:	DC 3.3 V
Frequency:	2441 MHz	Temp.(°C)/Hum.(%RH):	26(°C)/60 %RH
Mode:	Mode 2		
Ant.Polar.:	Horizontal		

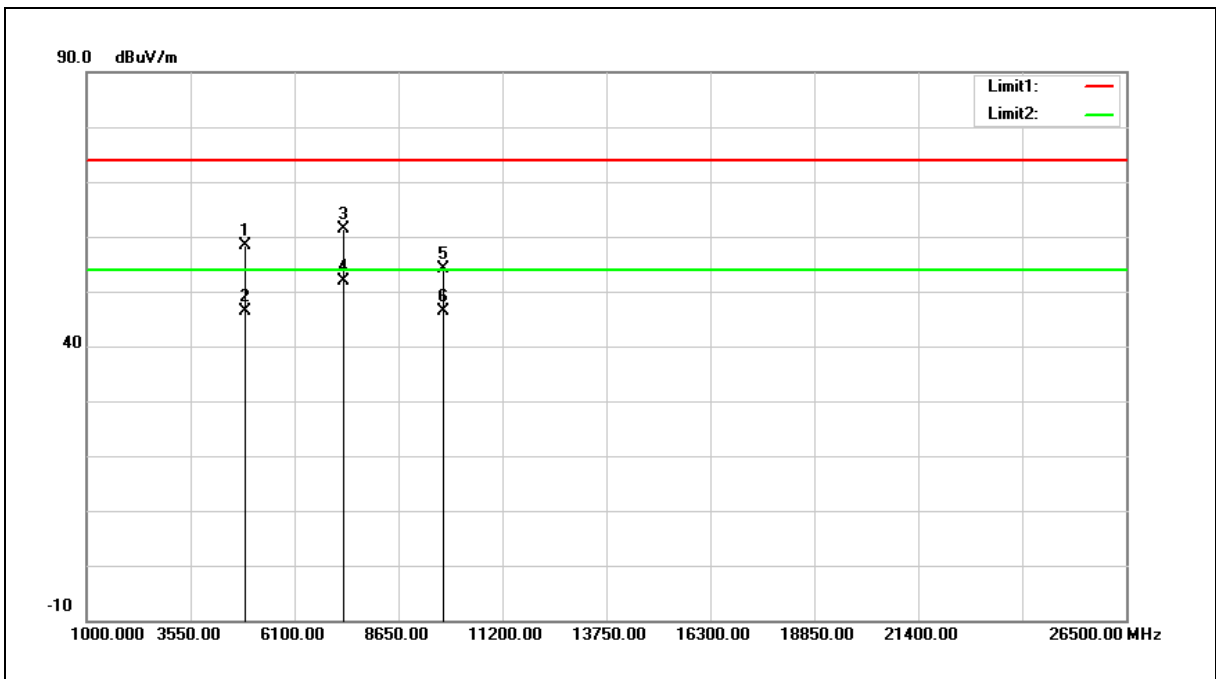

No.	Frequency (MHz)	Reading (dBuV)	Correct Factor (dB/m)	Result (dBuV/m)	Limit (dBuV/m)	Margin (dB)	Remark
1	4882.000	51.05	7.40	58.45	74.00	-15.55	peak
2	4882.000	39.00	7.40	46.40	54.00	-7.60	AVG
3	7323.000	51.33	9.97	61.30	74.00	-12.70	peak
4	7323.000	41.85	9.97	51.82	54.00	-2.18	AVG
5	9764.000	42.18	11.85	54.03	74.00	-19.97	peak
6	9764.000	34.59	11.85	46.44	54.00	-7.56	AVG

Note:1.Result (dBuV/m) = Correct Factor (dB/m) + Reading(dBuV).

2.Correction factor (dB/m) = Antenna Factor (dB/m) + Cable loss (dB) – Pre-Amplifier gain (dB).

3.When the peak results are less than average limit, so not need to evaluate the average.



Standard:	FCC Part 15.247	Test Distance:	3 m
Test item:	Harmonic	Power:	DC 3.3 V
Frequency:	2441 MHz	Temp.(°C)/Hum.(%RH):	26(°C)/60 %RH
Mode:	Mode 2		
Ant.Polar.:	Vertical		

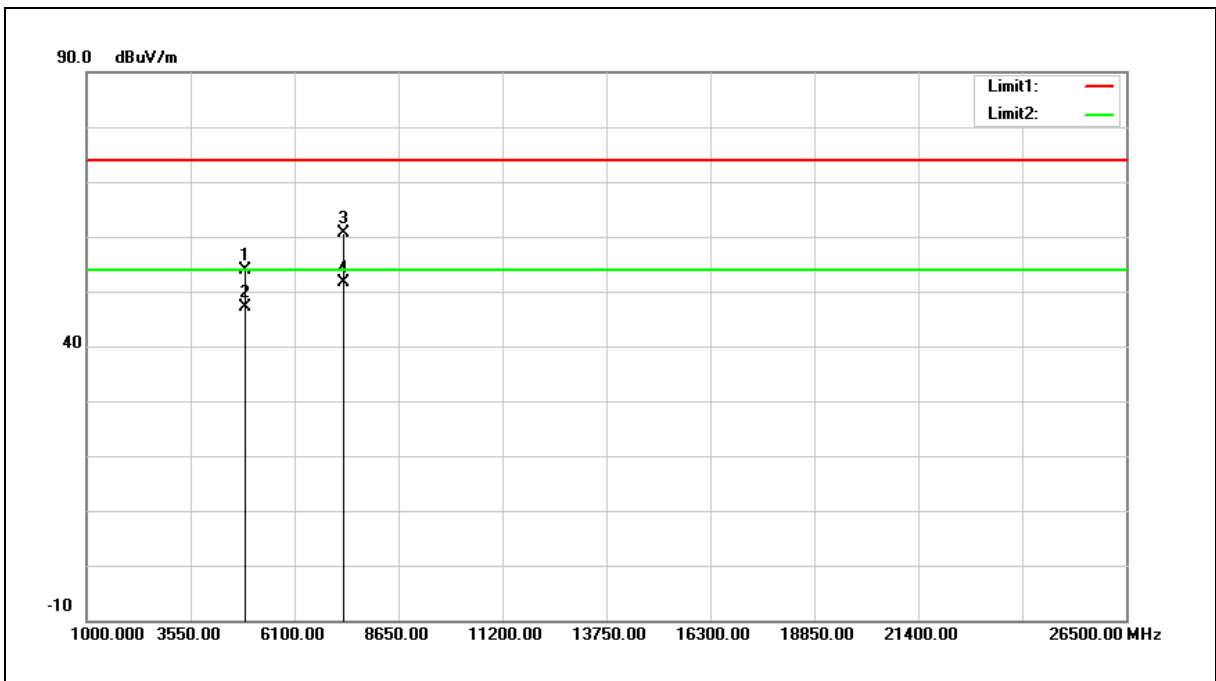

No.	Frequency (MHz)	Reading (dBuV)	Correct Factor (dB/m)	Result (dBuV/m)	Limit (dBuV/m)	Margin (dB)	Remark
1	4882.000	46.59	7.40	53.99	74.00	-20.01	peak
2	4882.000	39.67	7.40	47.07	54.00	-6.93	AVG
3	7323.000	50.62	9.97	60.59	74.00	-13.41	peak
4	7323.000	41.59	9.97	51.56	54.00	-2.44	AVG

Note:1.Result (dBuV/m) = Correct Factor (dB/m) + Reading(dBuV).  
 2.Correction factor (dB/m) = Antenna Factor (dB/m) + Cable loss (dB) – Pre-Amplifier gain (dB).  
 3.When the peak results are less than average limit, so not need to evaluate the average.

Standard:	FCC Part 15.247	Test Distance:	3 m
Test item:	Harmonic	Power:	DC 3.3 V
Frequency:	2480 MHz	Temp.(°C)/Hum.(%RH):	26(°C)/60 %RH
Mode:	Mode 2		
Ant.Polar.:	Horizontal		

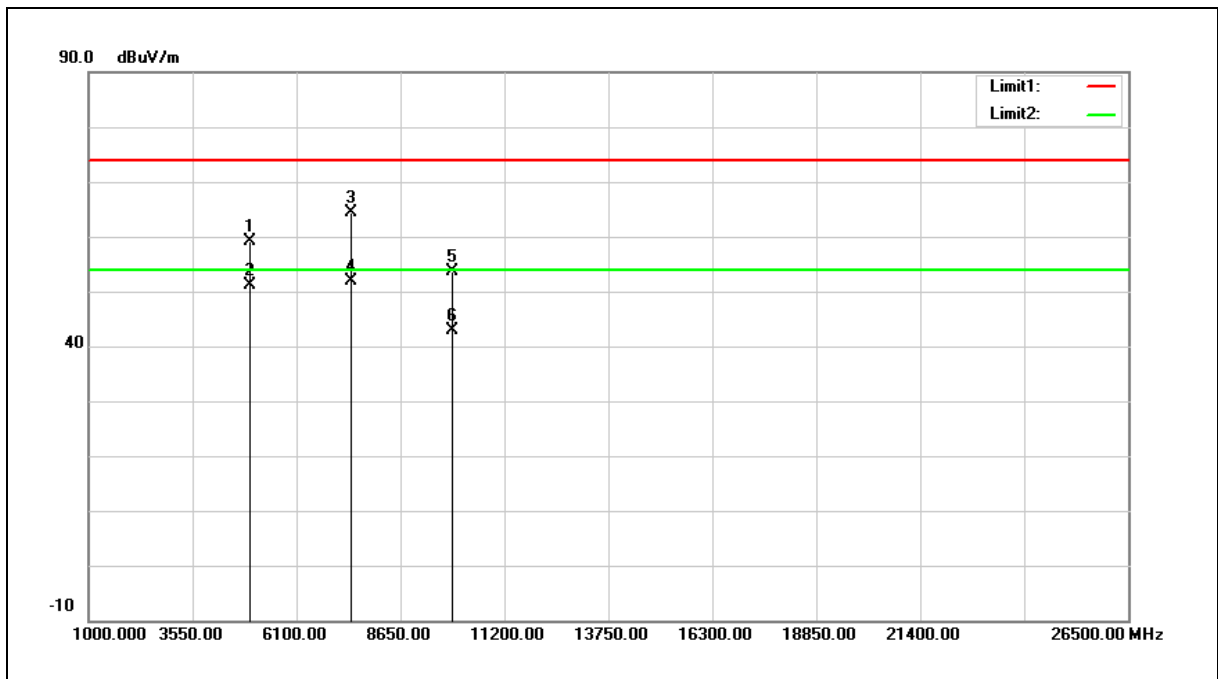

No.	Frequency (MHz)	Reading (dBuV)	Correct Factor (dB/m)	Result (dBuV/m)	Limit (dBuV/m)	Margin (dB)	Remark
1	4960.000	51.58	7.49	59.07	74.00	-14.93	peak
2	4960.000	43.74	7.49	51.23	54.00	-2.77	AVG
3	7440.000	54.43	9.99	64.42	74.00	-9.58	peak
4	7440.000	41.99	9.99	51.98	54.00	-2.02	AVG
5	9920.000	41.36	12.26	53.62	74.00	-20.38	peak
6	9920.000	30.64	12.26	42.90	54.00	-11.10	AVG

Note:1.Result (dBuV/m) = Correct Factor (dB/m) + Reading(dBuV).

2.Correction factor (dB/m) = Antenna Factor (dB/m) + Cable loss (dB) – Pre-Amplifier gain (dB).

3.When the peak results are less than average limit, so not need to evaluate the average.



Standard:	FCC Part 15.247	Test Distance:	3 m
Test item:	Harmonic	Power:	DC 3.3 V
Frequency:	2480 MHz	Temp.(°C)/Hum.(%RH):	26(°C)/60 %RH
Mode:	Mode 2		
Ant.Polar.:	Vertical		

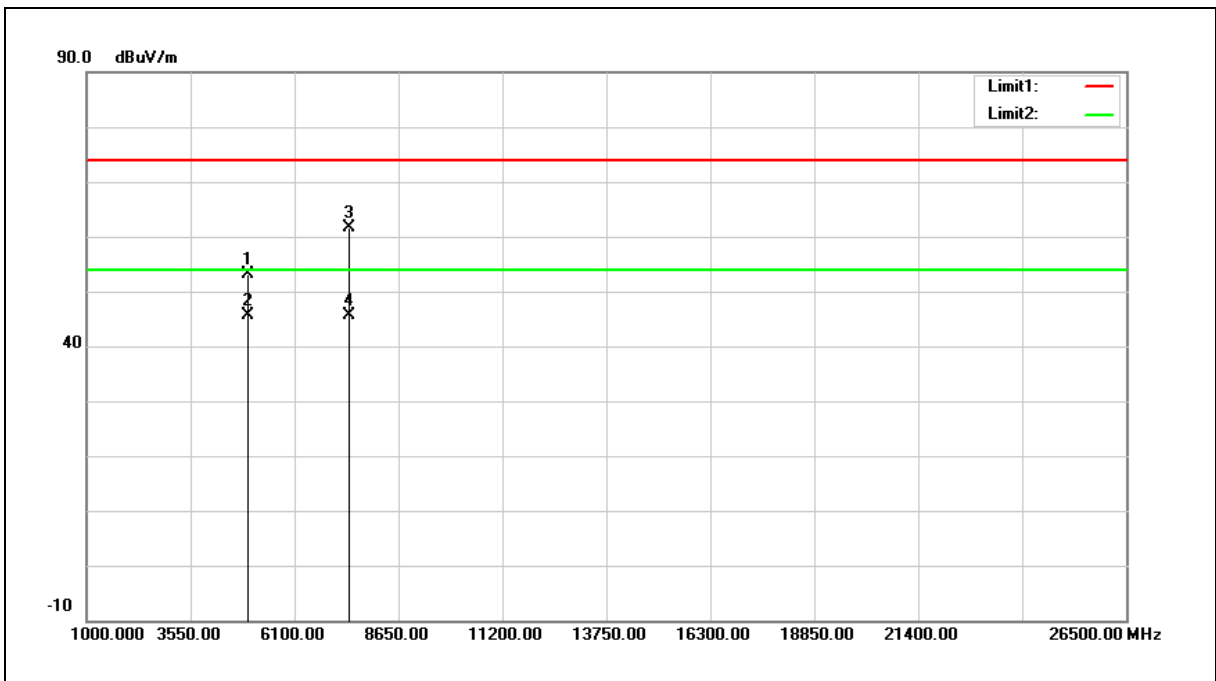

No.	Frequency (MHz)	Reading (dBuV)	Correct Factor (dB/m)	Result (dBuV/m)	Limit (dBuV/m)	Margin (dB)	Remark
1	4960.000	45.53	7.49	53.02	74.00	-20.98	peak
2	4960.000	38.16	7.49	45.65	54.00	-8.35	AVG
3	7440.000	51.58	9.99	61.57	74.00	-12.43	peak
4	7440.000	35.53	9.99	45.52	54.00	-8.48	AVG

- Note:1.Result (dBuV/m) = Correct Factor (dB/m) + Reading(dBuV).  
 2.Correction factor (dB/m) = Antenna Factor (dB/m) + Cable loss (dB) – Pre-Amplifier gain (dB).  
 3.When the peak results are less than average limit, so not need to evaluate the average.



Standard:	FCC Part 15.247	Test Distance:	3 m
Test item:	Harmonic	Power:	DC 3.3 V
Frequency:	2402 MHz	Temp.(°C)/Hum.(%RH):	26(°C)/60 %RH
Mode:	Mode 4		
Ant.Polar.:	Horizontal		

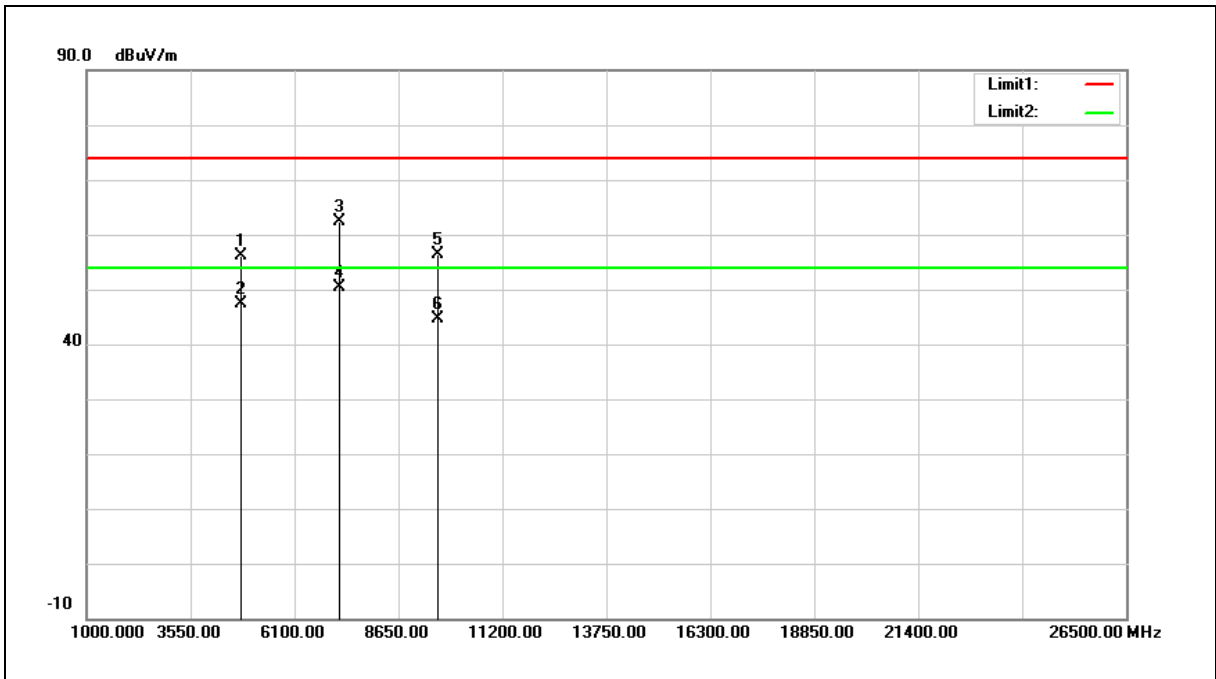

No.	Frequency (MHz)	Reading (dBuV)	Correct Factor (dB/m)	Result (dBuV/m)	Limit (dBuV/m)	Margin (dB)	Remark
1	4804.000	48.95	7.30	56.25	74.00	-17.75	peak
2	4804.000	40.01	7.30	47.31	54.00	-6.69	AVG
3	7206.000	52.32	9.95	62.27	74.00	-11.73	peak
4	7206.000	40.33	9.95	50.28	54.00	-3.72	AVG
5	9608.000	45.03	11.45	56.48	74.00	-17.52	peak
6	9608.000	33.28	11.45	44.73	54.00	-9.27	AVG

Note:1.Result (dBuV/m) = Correct Factor (dB/m) + Reading(dBuV).

2.Correction factor (dB/m) = Antenna Factor (dB/m) + Cable loss (dB) – Pre-Amplifier gain (dB).

3.When the peak results are less than average limit, so not need to evaluate the average.



Standard:	FCC Part 15.247	Test Distance:	3 m
Test item:	Harmonic	Power:	DC 3.3 V
Frequency:	2402 MHz	Temp.(°C)/Hum.(%RH):	26(°C)/60 %RH
Mode:	Mode 4		
Ant.Polar.:	Vertical		

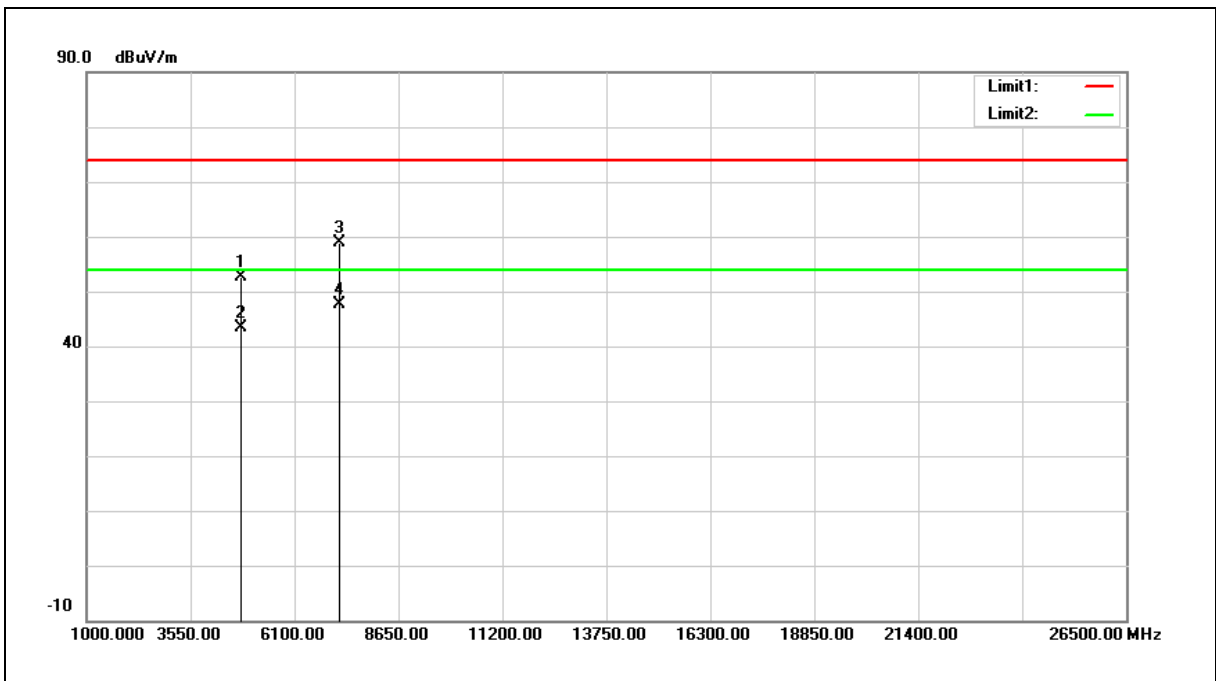

No.	Frequency (MHz)	Reading (dBuV)	Correct Factor (dB/m)	Result (dBuV/m)	Limit (dBuV/m)	Margin (dB)	Remark
1	4804.000	45.34	7.30	52.64	74.00	-21.36	peak
2	4804.000	36.03	7.30	43.33	54.00	-10.67	AVG
3	7206.000	49.00	9.95	58.95	74.00	-15.05	peak
4	7206.000	37.77	9.95	47.72	54.00	-6.28	AVG

Note:1.Result (dBuV/m) = Correct Factor (dB/m) + Reading(dBuV).

2.Correction factor (dB/m) = Antenna Factor (dB/m) + Cable loss (dB) – Pre-Amplifier gain (dB).

3.When the peak results are less than average limit, so not need to evaluate the average.



Standard:	FCC Part 15.247	Test Distance:	3 m
Test item:	Harmonic	Power:	DC 3.3 V
Frequency:	2441 MHz	Temp.(°C)/Hum.(%RH):	26(°C)/60 %RH
Mode:	Mode 4		
Ant.Polar.:	Horizontal		

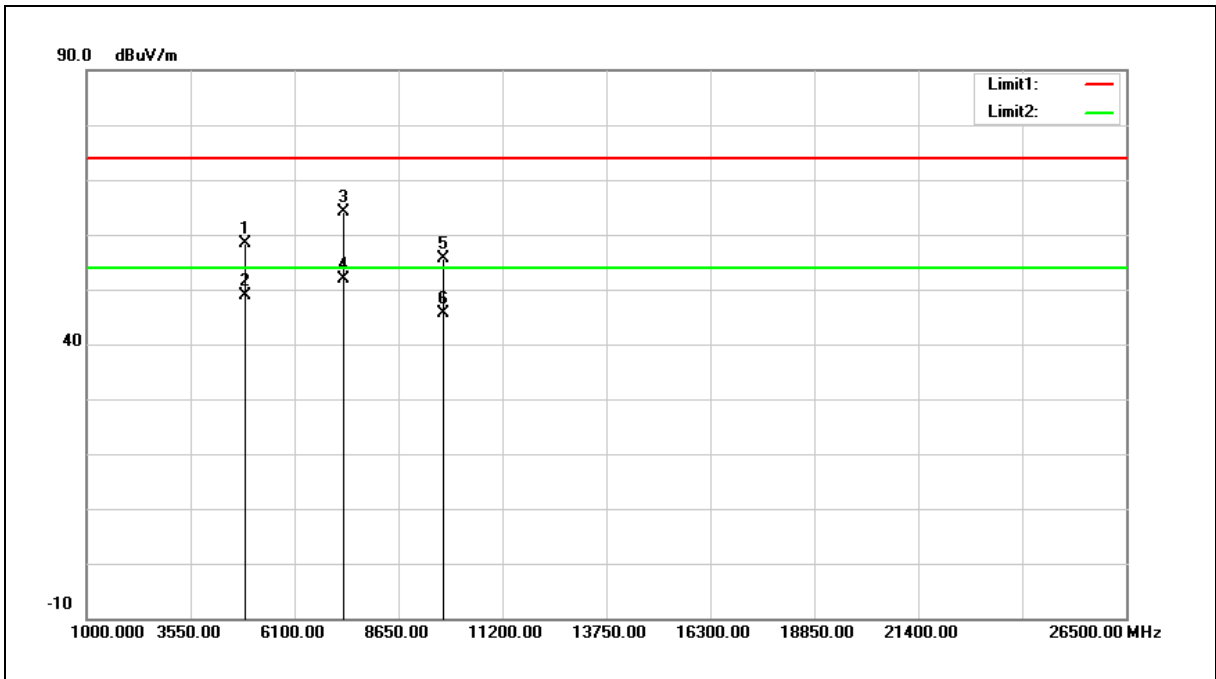

No.	Frequency (MHz)	Reading (dBuV)	Correct Factor (dB/m)	Result (dBuV/m)	Limit (dBuV/m)	Margin (dB)	Remark
1	4882.000	50.98	7.40	58.38	74.00	-15.62	peak
2	4882.000	41.56	7.40	48.96	54.00	-5.04	AVG
3	7323.000	54.17	9.97	64.14	74.00	-9.86	peak
4	7323.000	41.84	9.97	51.81	54.00	-2.19	AVG
5	9764.000	43.74	11.85	55.59	74.00	-18.41	peak
6	9764.000	33.88	11.85	45.73	54.00	-8.27	AVG

Note:1.Result (dBuV/m) = Correct Factor (dB/m) + Reading(dBuV).

2.Correction factor (dB/m) = Antenna Factor (dB/m) + Cable loss (dB) – Pre-Amplifier gain (dB).

3.When the peak results are less than average limit, so not need to evaluate the average.



Standard:	FCC Part 15.247	Test Distance:	3 m
Test item:	Harmonic	Power:	DC 3.3 V
Frequency:	2441 MHz	Temp.(°C)/Hum.(%RH):	26(°C)/60 %RH
Mode:	Mode 4		
Ant.Polar.:	Vertical		

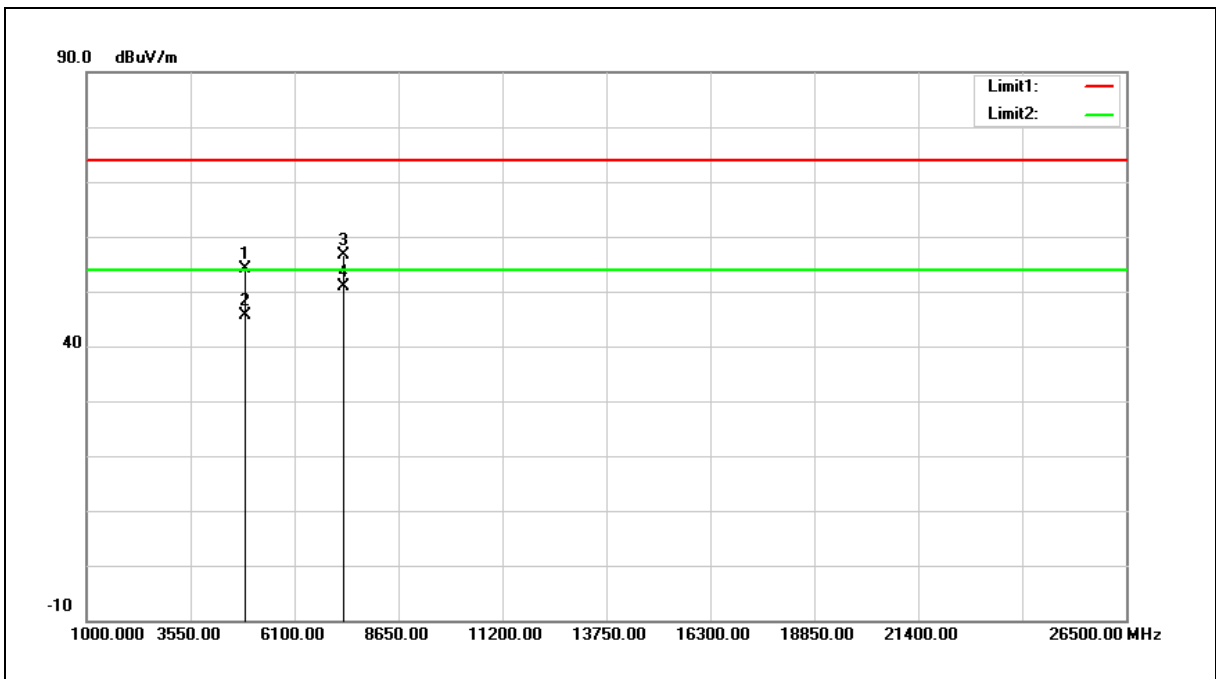

No.	Frequency (MHz)	Reading (dBuV)	Correct Factor (dB/m)	Result (dBuV/m)	Limit (dBuV/m)	Margin (dB)	Remark
1	4882.000	46.81	7.40	54.21	74.00	-19.79	peak
2	4882.000	38.33	7.40	45.73	54.00	-8.27	AVG
3	7323.000	46.62	9.97	56.59	74.00	-17.41	peak
4	7323.000	40.98	9.97	50.95	54.00	-3.05	AVG

Note:1.Result (dBuV/m) = Correct Factor (dB/m) + Reading(dBuV).

2.Correction factor (dB/m) = Antenna Factor (dB/m) + Cable loss (dB) – Pre-Amplifier gain (dB).

3.When the peak results are less than average limit, so not need to evaluate the average.



Standard:	FCC Part 15.247	Test Distance:	3 m
Test item:	Harmonic	Power:	DC 3.3 V
Frequency:	2480 MHz	Temp.(°C)/Hum.(%RH):	26(°C)/60 %RH
Mode:	Mode 4		
Ant.Polar.:	Horizontal		

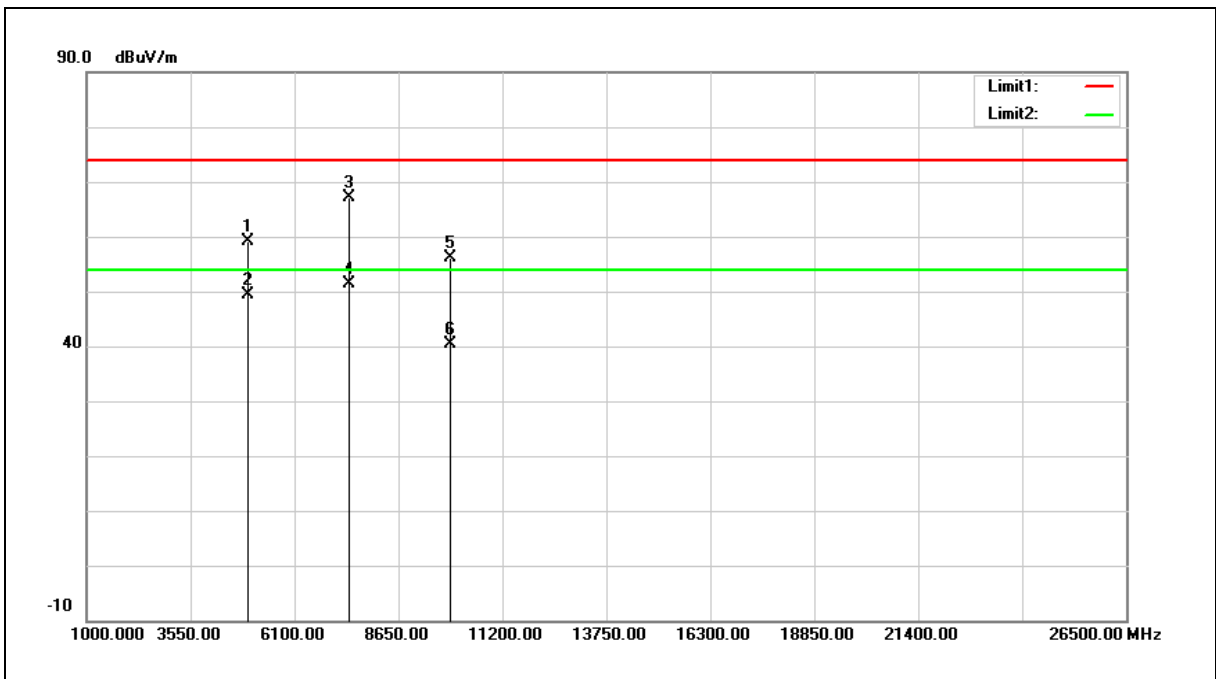

No.	Frequency (MHz)	Reading (dBuV)	Correct Factor (dB/m)	Result (dBuV/m)	Limit (dBuV/m)	Margin (dB)	Remark
1	4960.000	51.53	7.49	59.02	74.00	-14.98	peak
2	4960.000	41.89	7.49	49.38	54.00	-4.62	AVG
3	7440.000	57.26	9.99	67.25	74.00	-6.75	peak
4	7440.000	41.50	9.99	51.49	54.00	-2.51	AVG
5	9920.000	43.76	12.26	56.02	74.00	-17.98	peak
6	9920.000	28.20	12.26	40.46	54.00	-13.54	AVG

Note:1.Result (dBuV/m) = Correct Factor (dB/m) + Reading(dBuV).

2.Correction factor (dB/m) = Antenna Factor (dB/m) + Cable loss (dB) – Pre-Amplifier gain (dB).

3.When the peak results are less than average limit, so not need to evaluate the average.



Standard:	FCC Part 15.247	Test Distance:	3 m
Test item:	Harmonic	Power:	DC 3.3 V
Frequency:	2480 MHz	Temp.(°C)/Hum.(%RH):	26(°C)/60 %RH
Mode:	Mode 4		
Ant.Polar.:	Vertical		

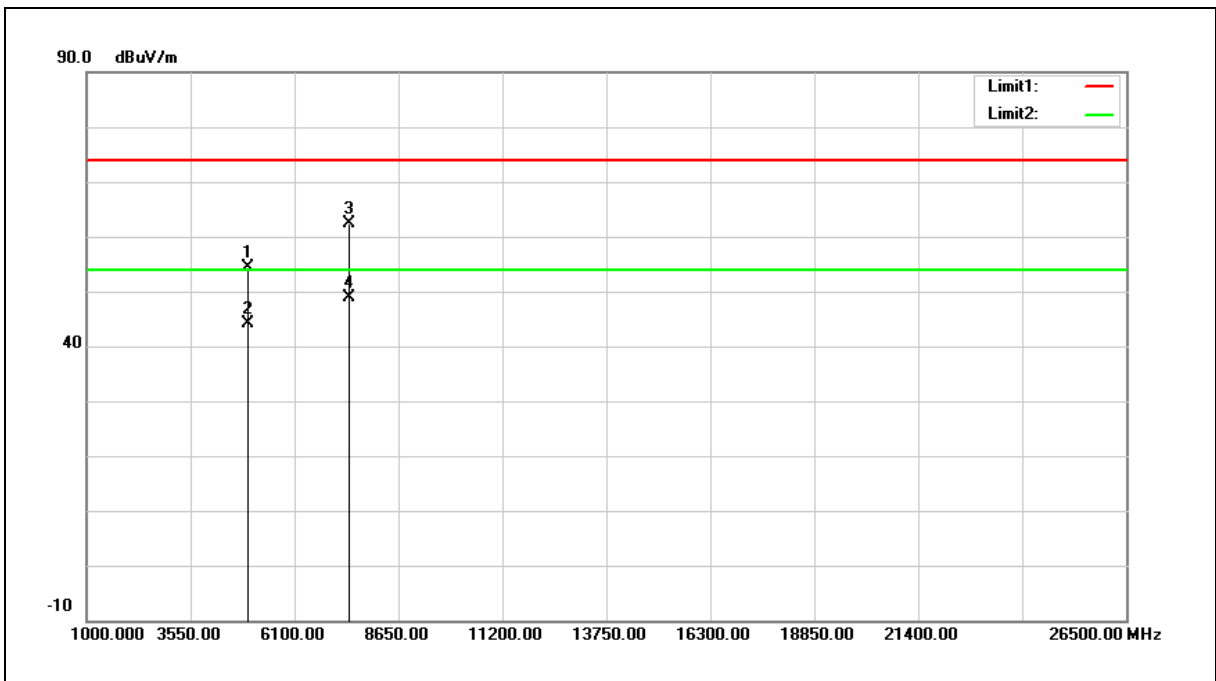

No.	Frequency (MHz)	Reading (dBuV)	Correct Factor (dB/m)	Result (dBuV/m)	Limit (dBuV/m)	Margin (dB)	Remark
1	4960.000	46.79	7.49	54.28	74.00	-19.72	peak
2	4960.000	36.52	7.49	44.01	54.00	-9.99	AVG
3	7440.000	52.41	9.99	62.40	74.00	-11.60	peak
4	7440.000	38.90	9.99	48.89	54.00	-5.11	AVG

- Note:1.Result (dBuV/m) = Correct Factor (dB/m) + Reading(dBuV).
- 2.Correction factor (dB/m) = Antenna Factor (dB/m) + Cable loss (dB) – Pre-Amplifier gain (dB).
- 3.When the peak results are less than average limit, so not need to evaluate the average.



Antenna Type: Heavy Duty Screw Mount Antenna

Below 1 GHz

Standard:	FCC Part 15.247	Test Distance:	3 m
Test item:	Harmonic	Power:	DC 3.3 V
Test Mode:	Mode 1	Temp.(°C)/Hum.(%RH):	26(°C)/60 %RH

Frequency (MHz)	Reading (dBuV)	Correct Factor (dB/m)	Result (dBuV/m)	Limit (dBuV/m)	Margin (dB)	Remark	Ant.Polar. H / V
78.5000	43.21	-14.53	28.68	40.00	-11.32	QP	H
114.3900	39.54	-13.62	25.92	43.50	-17.58	QP	H
174.5300	39.46	-10.74	28.72	43.50	-14.78	QP	H
267.6500	40.20	-11.35	28.85	46.00	-17.15	QP	H
691.5400	36.38	-1.99	34.39	46.00	-11.61	QP	H
877.7800	35.99	1.09	37.08	46.00	-8.92	QP	H
67.8300	40.57	-12.59	27.98	40.00	-12.02	QP	V
174.5300	39.35	-10.74	28.61	43.50	-14.89	QP	V
226.9100	36.79	-12.85	23.94	46.00	-22.06	QP	V
462.6200	35.59	-5.95	29.64	46.00	-16.36	QP	V
700.2700	34.71	-1.98	32.73	46.00	-13.27	QP	V
857.4100	36.47	0.94	37.41	46.00	-8.59	QP	V

Note:1.Result (dBuV/m) = Correct Factor (dB/m) + Reading(dBuV).

2.Correction factor (dB/m) = Antenna Factor (dB/m) + Cable loss (dB) – Pre-Amplifier gain (dB).

3. When the peak results are less than average limit, so not need to evaluate the average.



Above 1 GHz

Standard:	FCC Part 15.247	Test Distance:	3 m
Test item:	Harmonic	Power:	DC 3.3 V
Frequency:	2402 MHz	Temp.(°C)/Hum.(%RH):	26(°C)/60 %RH
Mode:	Mode 2		
Ant.Polar.:	Horizontal		

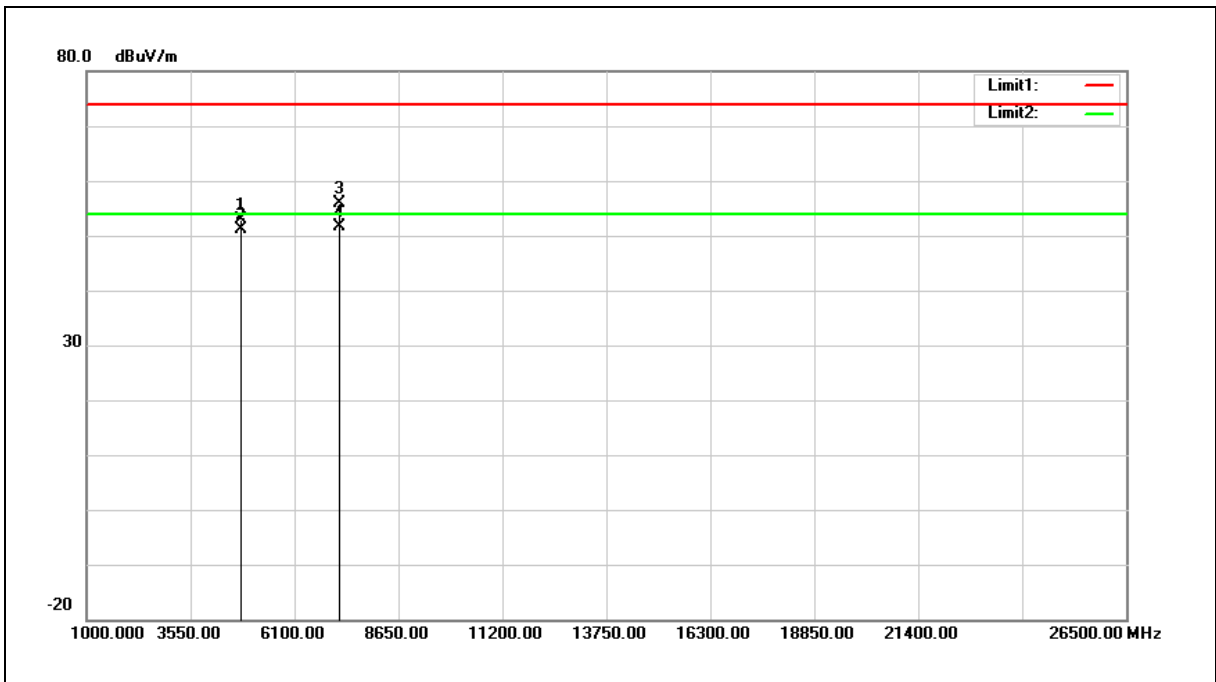

No.	Frequency (MHz)	Reading (dBuV)	Correct Factor (dB/m)	Result (dBuV/m)	Limit (dBuV/m)	Margin (dB)	Remark
1	4804.000	57.81	-4.81	53.00	74.00	-21.00	peak
2	4804.000	55.93	-4.81	51.12	54.00	-2.88	AVG
3	7206.000	56.28	-0.51	55.77	74.00	-18.23	peak
4	7206.000	52.08	-0.51	51.57	54.00	-2.43	AVG

Note:1.Result (dBuV/m) = Correct Factor (dB/m) + Reading(dBuV).

2.Correction factor (dB/m) = Antenna Factor (dB/m) + Cable loss (dB) – Pre-Amplifier gain (dB).

3.When the peak results are less than average limit, so not need to evaluate the average.



Standard:	FCC Part 15.247	Test Distance:	3 m
Test item:	Harmonic	Power:	DC 3.3 V
Frequency:	2402 MHz	Temp.(°C)/Hum.(%RH):	26(°C)/60 %RH
Mode:	Mode 2		
Ant.Polar.:	Vertical		

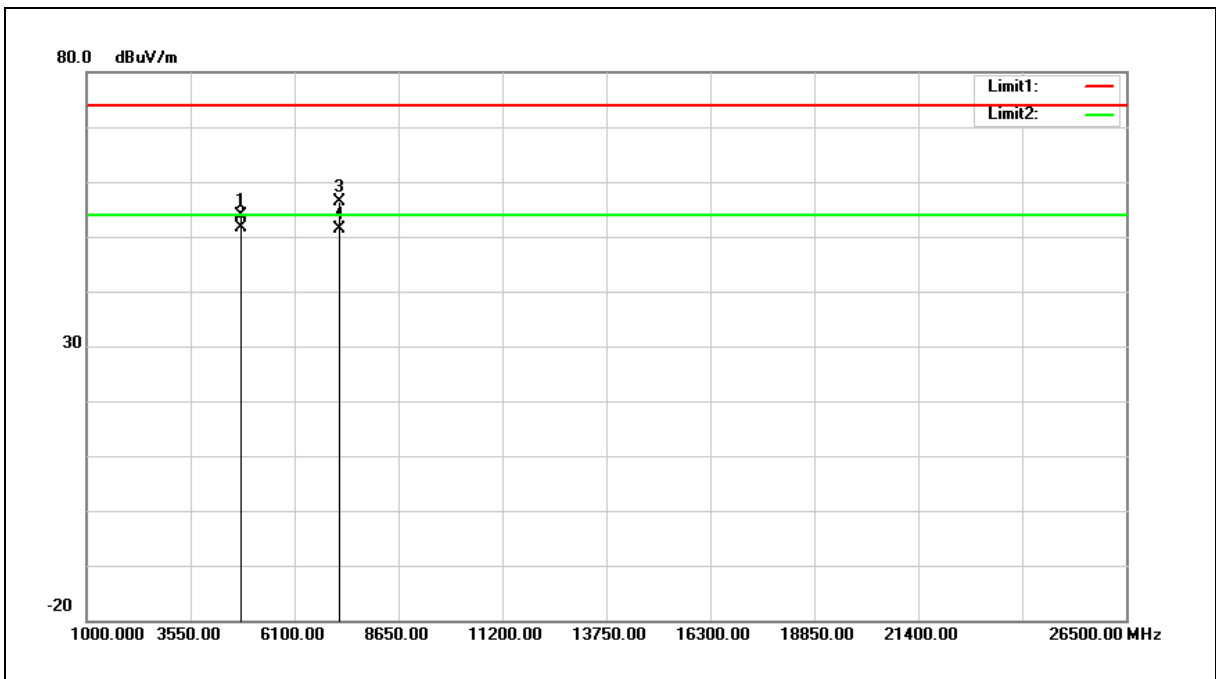

No.	Frequency (MHz)	Reading (dBuV)	Correct Factor (dB/m)	Result (dBuV/m)	Limit (dBuV/m)	Margin (dB)	Remark
1	4804.000	58.80	-4.81	53.99	74.00	-20.01	peak
2	4804.000	56.43	-4.81	51.62	54.00	-2.38	AVG
3	7206.000	56.77	-0.51	56.26	74.00	-17.74	peak
4	7206.000	51.85	-0.51	51.34	54.00	-2.66	AVG

Note:1.Result (dBuV/m) = Correct Factor (dB/m) + Reading(dBuV).

2.Correction factor (dB/m) = Antenna Factor (dB/m) + Cable loss (dB) – Pre-Amplifier gain (dB).

3.When the peak results are less than average limit, so not need to evaluate the average.





Standard:	FCC Part 15.247	Test Distance:	3m
Test item:	Harmonic	Power:	DC 3.3 V
Frequency:	2441 MHz	Temp.( )/Hum.(%RH):	26(°C)/60 %RH
Mode:	Mode 2		
Ant.Polar.:	Horizontal		

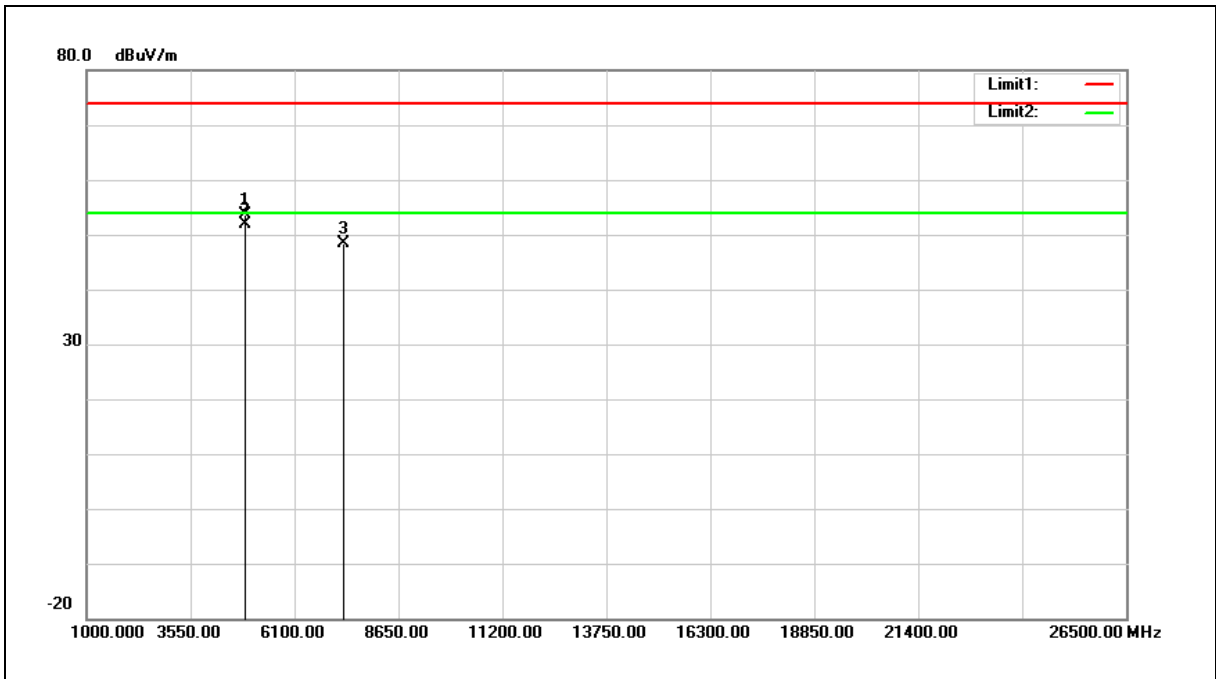

No.	Frequency (MHz)	Reading (dBuV)	Correct Factor (dB/m)	Result (dBuV/m)	Limit (dBuV/m)	Margin (dB)	Remark
1	4882.000	58.36	-4.85	53.51	74.00	-20.49	peak
2	4882.000	56.85	-4.85	52.00	54.00	-2.00	AVG
3	7323.000	48.51	-0.20	48.31	74.00	-25.69	peak

Note:1.Result (dBuV/m) = Correct Factor (dB/m) + Reading(dBuV).

2.Correction factor (dB/m) = Antenna Factor (dB/m) + Cable loss (dB) – Pre-Amplifier gain (dB).

3.When the peak results are less than average limit, so not need to evaluate the average.



Standard:	FCC Part 15.247	Test Distance:	3 m
Test item:	Harmonic	Power:	DC 3.3 V
Frequency:	2441 MHz	Temp.(°C)/Hum.(%RH):	26(°C)/60 %RH
Mode:	Mode 2		
Ant.Polar.:	Vertical		

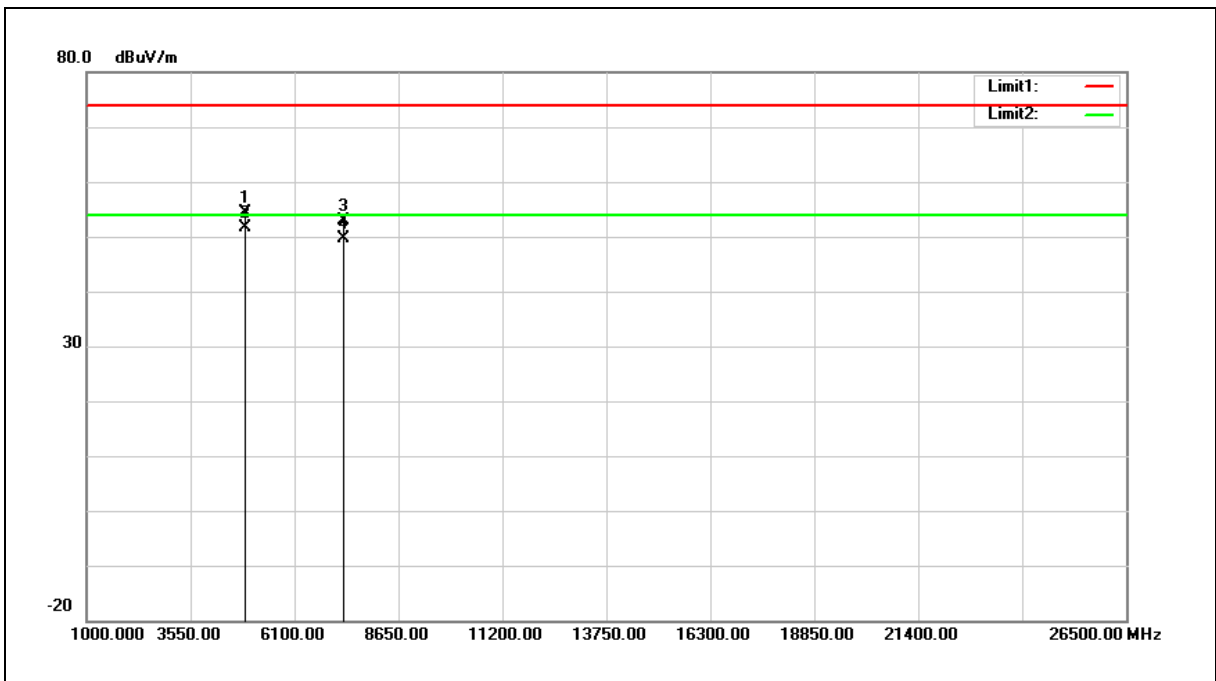

No.	Frequency (MHz)	Reading (dBuV)	Correct Factor (dB/m)	Result (dBuV/m)	Limit (dBuV/m)	Margin (dB)	Remark
1	4882.000	59.19	-4.85	54.34	74.00	-19.66	peak
2	4882.000	56.58	-4.85	51.73	54.00	-2.27	AVG
3	7323.000	52.97	-0.20	52.77	74.00	-21.23	peak
4	7323.000	49.88	-0.20	49.68	54.00	-4.32	AVG

- Note:1.Result (dBuV/m) = Correct Factor (dB/m) + Reading(dBuV).  
 2.Correction factor (dB/m) = Antenna Factor (dB/m) + Cable loss (dB) – Pre-Amplifier gain (dB).  
 3.When the peak results are less than average limit, so not need to evaluate the average.



Standard:	FCC Part 15.247	Test Distance:	3 m
Test item:	Harmonic	Power:	DC 3.3 V
Frequency:	2480 MHz	Temp.(°C)/Hum.(%RH):	26(°C)/60 %RH
Mode:	Mode 2		
Ant.Polar.:	Horizontal		

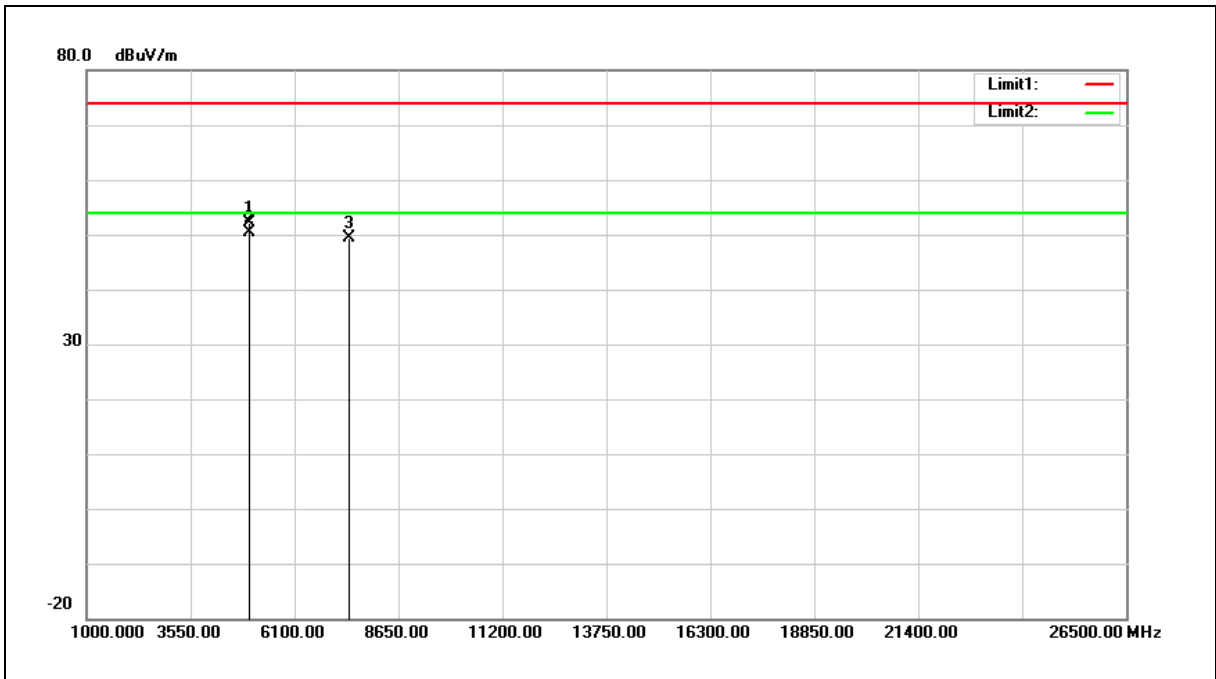

No.	Frequency (MHz)	Reading (dBuV)	Correct Factor (dB/m)	Result (dBuV/m)	Limit (dBuV/m)	Margin (dB)	Remark
1	4960.000	57.09	-4.89	52.20	74.00	-21.80	peak
2	4960.000	55.18	-4.89	50.29	54.00	-3.71	AVG
3	7440.000	49.42	0.06	49.48	74.00	-24.52	peak

Note:1.Result (dBuV/m) = Correct Factor (dB/m) + Reading(dBuV).

2.Correction factor (dB/m) = Antenna Factor (dB/m) + Cable loss (dB) – Pre-Amplifier gain (dB).

3.When the peak results are less than average limit, so not need to evaluate the average.



Standard:	FCC Part 15.247	Test Distance:	3 m
Test item:	Harmonic	Power:	DC 3.3 V
Frequency:	2480 MHz	Temp.(°C)/Hum.(%RH):	26(°C)/60 %RH
Mode:	Mode 2		
Ant.Polar.:	Vertical		

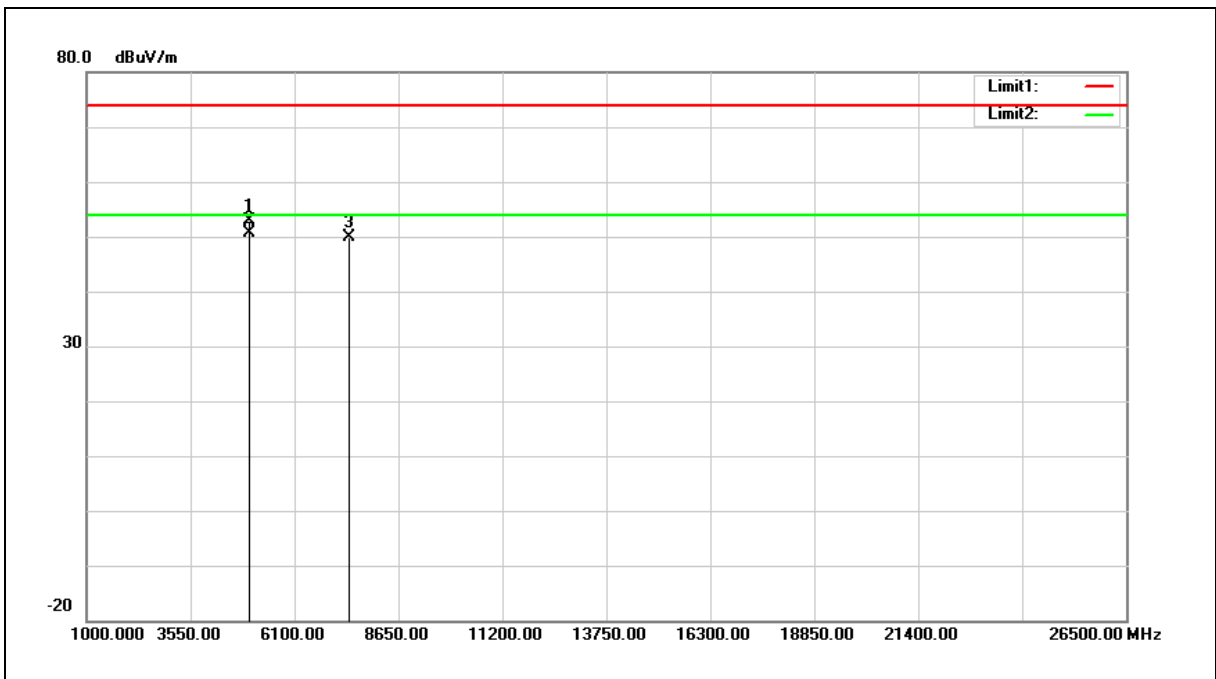

No.	Frequency (MHz)	Reading (dBuV)	Correct Factor (dB/m)	Result (dBuV/m)	Limit (dBuV/m)	Margin (dB)	Remark
1	4960.000	57.85	-4.89	52.96	74.00	-21.04	peak
2	4960.000	55.40	-4.89	50.51	54.00	-3.49	AVG
3	7440.000	49.94	0.06	50.00	74.00	-24.00	peak

Note:1.Result (dBuV/m) = Correct Factor (dB/m) + Reading(dBuV).

2.Correction factor (dB/m) = Antenna Factor (dB/m) + Cable loss (dB) – Pre-Amplifier gain (dB).

3.When the peak results are less than average limit, so not need to evaluate the average.



Standard:	FCC Part 15.247	Test Distance:	3 m
Test item:	Harmonic	Power:	DC 3.3 V
Frequency:	2402 MHz	Temp.(°C)/Hum.(%RH):	26(°C)/60 %RH
Mode:	Mode 4		
Ant.Polar.:	Horizontal		

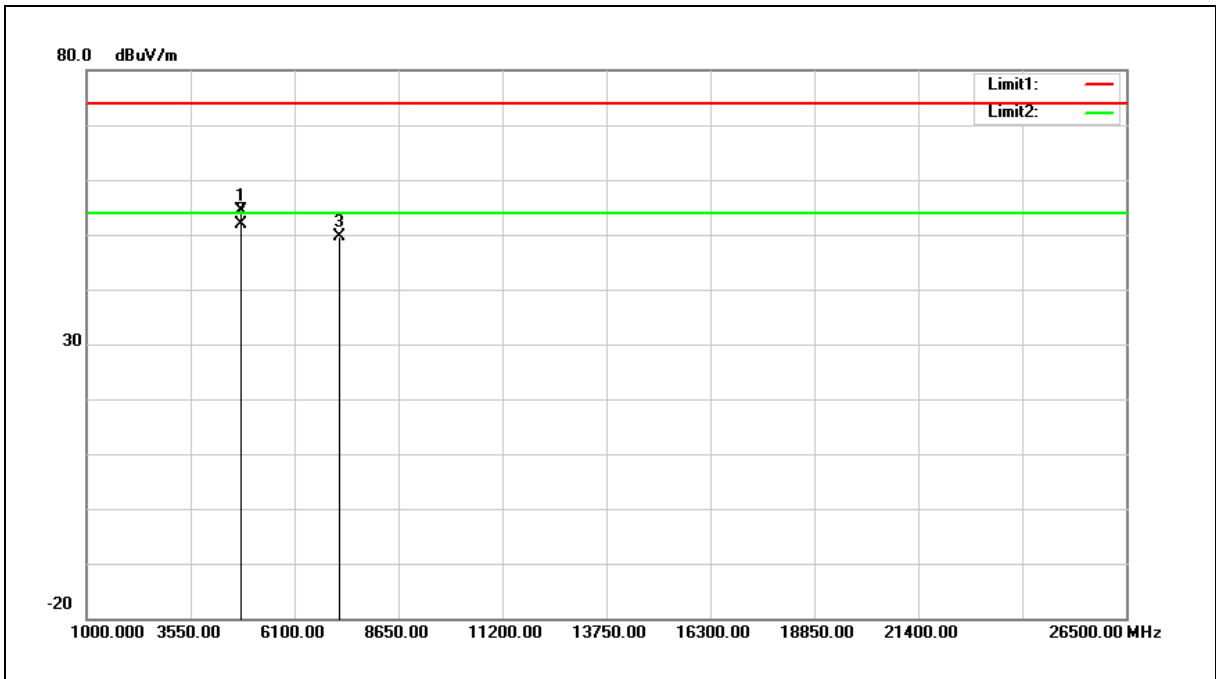

No.	Frequency (MHz)	Reading (dBuV)	Correct Factor (dB/m)	Result (dBuV/m)	Limit (dBuV/m)	Margin (dB)	Remark
1	4804.000	59.11	-4.81	54.30	74.00	-19.70	peak
2	4804.000	56.79	-4.81	51.98	54.00	-2.02	AVG
3	7206.000	50.03	-0.51	49.52	74.00	-24.48	peak

Note:1.Result (dBuV/m) = Correct Factor (dB/m) + Reading(dBuV).

2.Correction factor (dB/m) = Antenna Factor (dB/m) + Cable loss (dB) – Pre-Amplifier gain (dB).

3.When the peak results are less than average limit, so not need to evaluate the average.



Standard:	FCC Part 15.247	Test Distance:	3 m
Test item:	Harmonic	Power:	DC 3.3 V
Frequency:	2402 MHz	Temp.(°C)/Hum.(%RH):	26(°C)/60 %RH
Mode:	Mode 4		
Ant.Polar.:	Vertical		

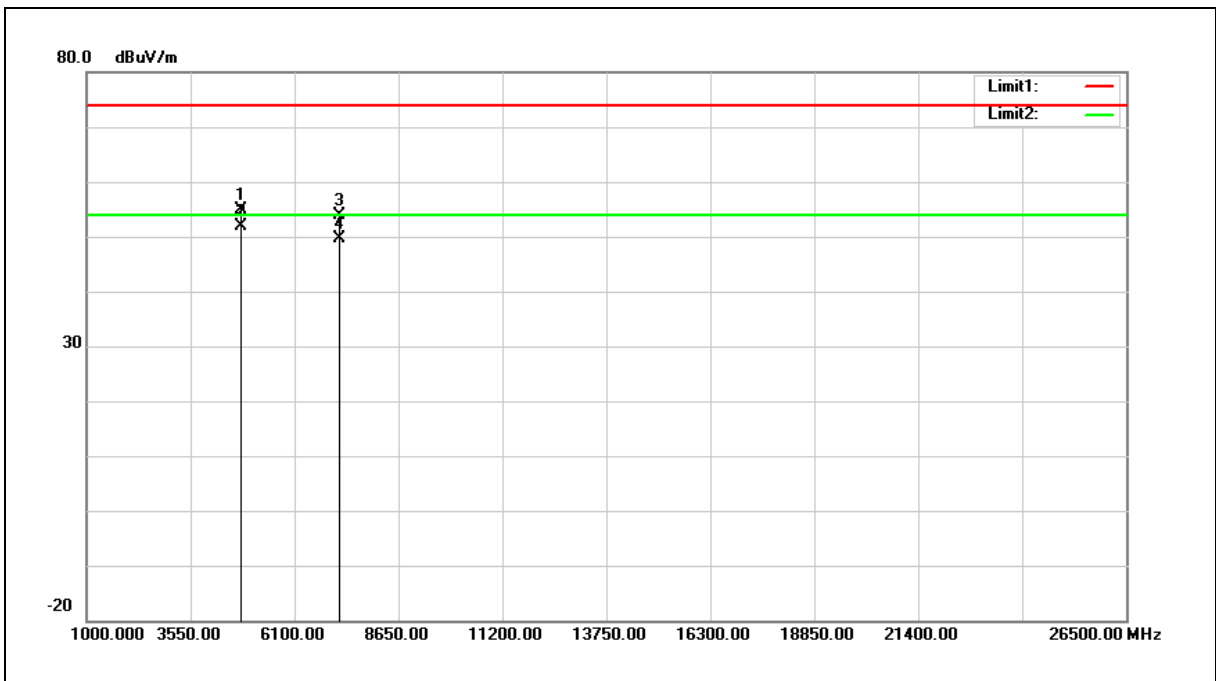

No.	Frequency (MHz)	Reading (dBuV)	Correct Factor (dB/m)	Result (dBuV/m)	Limit (dBuV/m)	Margin (dB)	Remark
1	4804.000	59.68	-4.81	54.87	74.00	-19.13	peak
2	4804.000	56.77	-4.81	51.96	54.00	-2.04	AVG
3	7206.000	54.35	-0.51	53.84	74.00	-20.16	peak
4	7206.000	50.02	-0.51	49.51	54.00	-4.49	AVG

- Note:1.Result (dBuV/m) = Correct Factor (dB/m) + Reading(dBuV).
- 2.Correction factor (dB/m) = Antenna Factor (dB/m) + Cable loss (dB) – Pre-Amplifier gain (dB).
- 3.When the peak results are less than average limit, so not need to evaluate the average.



Standard:	FCC Part 15.247	Test Distance:	3 m
Test item:	Harmonic	Power:	DC 3.3 V
Frequency:	2441 MHz	Temp.(°C)/Hum.(%RH):	26(°C)/60 %RH
Mode:	Mode 4		
Ant.Polar.:	Horizontal		

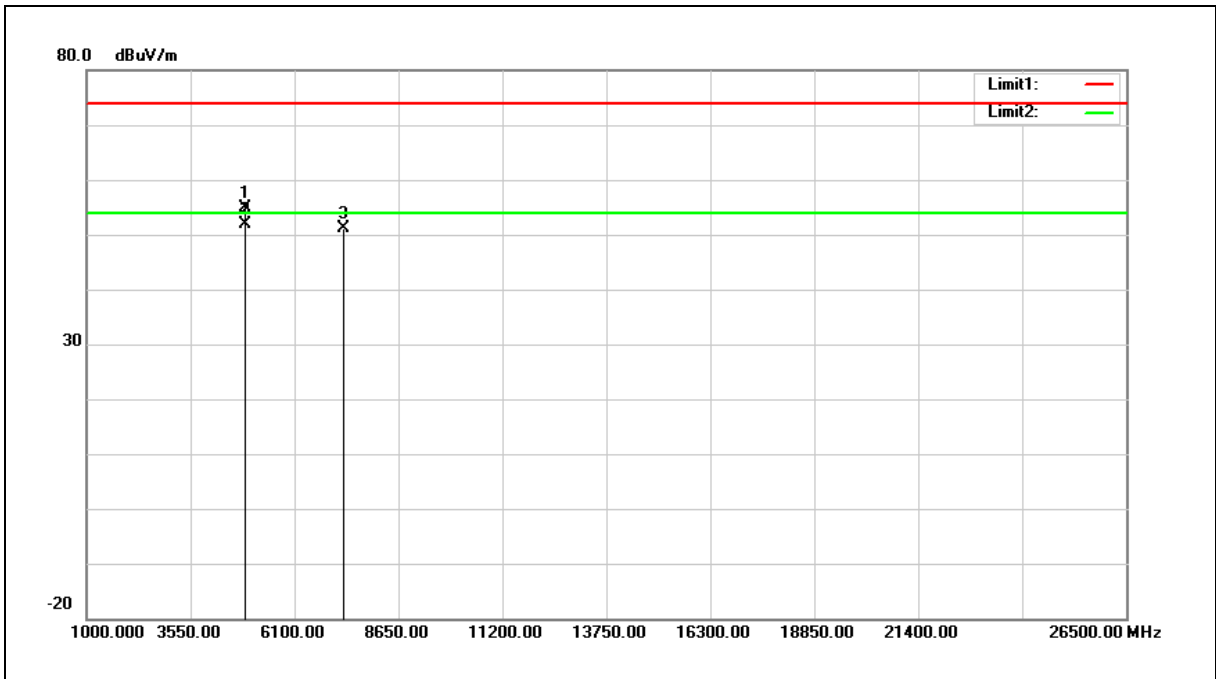

No.	Frequency (MHz)	Reading (dBuV)	Correct Factor (dB/m)	Result (dBuV/m)	Limit (dBuV/m)	Margin (dB)	Remark
1	4882.000	59.71	-4.85	54.86	74.00	-19.14	peak
2	4882.000	56.80	-4.85	51.95	54.00	-2.05	AVG
3	7323.000	51.22	-0.20	51.02	74.00	-22.98	peak

Note:1.Result (dBuV/m) = Correct Factor (dB/m) + Reading(dBuV).

2.Correction factor (dB/m) = Antenna Factor (dB/m) + Cable loss (dB) – Pre-Amplifier gain (dB).

3.When the peak results are less than average limit, so not need to evaluate the average.



Standard:	FCC Part 15.247	Test Distance:	3 m
Test item:	Harmonic	Power:	DC 3.3 V
Frequency:	2441 MHz	Temp.(°C)/Hum.(%RH):	26(°C)/60 %RH
Mode:	Mode 4		
Ant.Polar.:	Vertical		

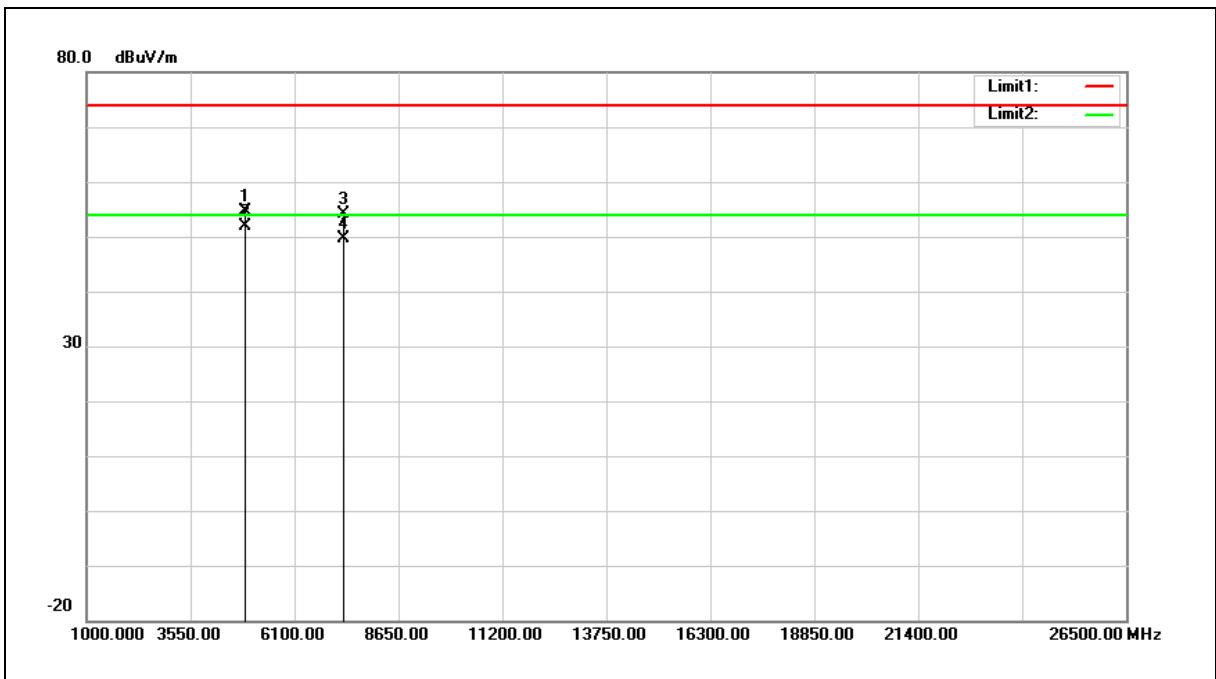

No.	Frequency (MHz)	Reading (dBuV)	Correct Factor (dB/m)	Result (dBuV/m)	Limit (dBuV/m)	Margin (dB)	Remark
1	4882.000	59.51	-4.85	54.66	74.00	-19.34	peak
2	4882.000	56.68	-4.85	51.83	54.00	-2.17	AVG
3	7323.000	54.44	-0.20	54.24	74.00	-19.76	peak
4	7323.000	49.87	-0.20	49.67	54.00	-4.33	AVG

- Note:1.Result (dBuV/m) = Correct Factor (dB/m) + Reading(dBuV).  
 2.Correction factor (dB/m) = Antenna Factor (dB/m) + Cable loss (dB) – Pre-Amplifier gain (dB).  
 3.When the peak results are less than average limit, so not need to evaluate the average.





Standard:	FCC Part 15.247	Test Distance:	3 m
Test item:	Harmonic	Power:	DC 3.3 V
Frequency:	2480 MHz	Temp.(°C)/Hum.(%RH):	26(°C)/60 %RH
Mode:	Mode 4		
Ant.Polar.:	Horizontal		

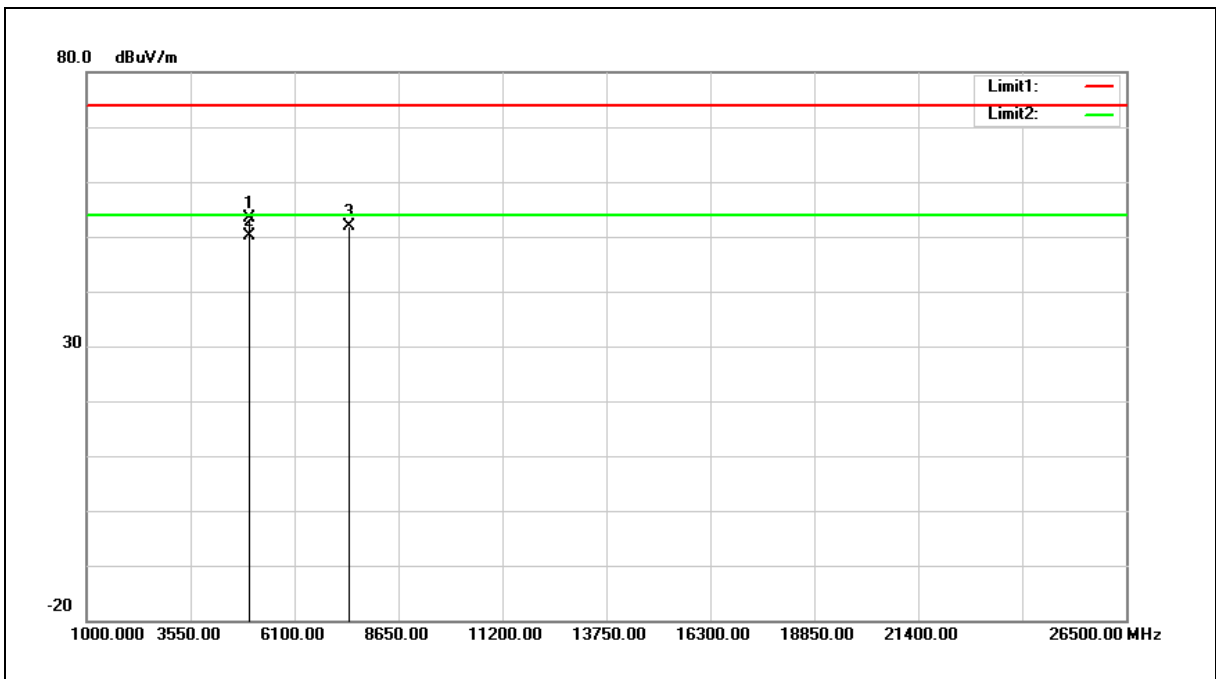

No.	Frequency (MHz)	Reading (dBuV)	Correct Factor (dB/m)	Result (dBuV/m)	Limit (dBuV/m)	Margin (dB)	Remark
1	4960.000	58.38	-4.89	53.49	74.00	-20.51	peak
2	4960.000	55.05	-4.89	50.16	54.00	-3.84	AVG
3	7440.000	51.81	0.06	51.87	74.00	-22.13	peak

Note:1.Result (dBuV/m) = Correct Factor (dB/m) + Reading(dBuV).

2.Correction factor (dB/m) = Antenna Factor (dB/m) + Cable loss (dB) – Pre-Amplifier gain (dB).

3.When the peak results are less than average limit, so not need to evaluate the average.



Standard:	FCC Part 15.247	Test Distance:	3 m
Test item:	Harmonic	Power:	DC 3.3 V
Frequency:	2480 MHz	Temp.(°C)/Hum.(%RH):	26(°C)/60 %RH
Mode:	Mode 4		
Ant.Polar.:	Vertical		

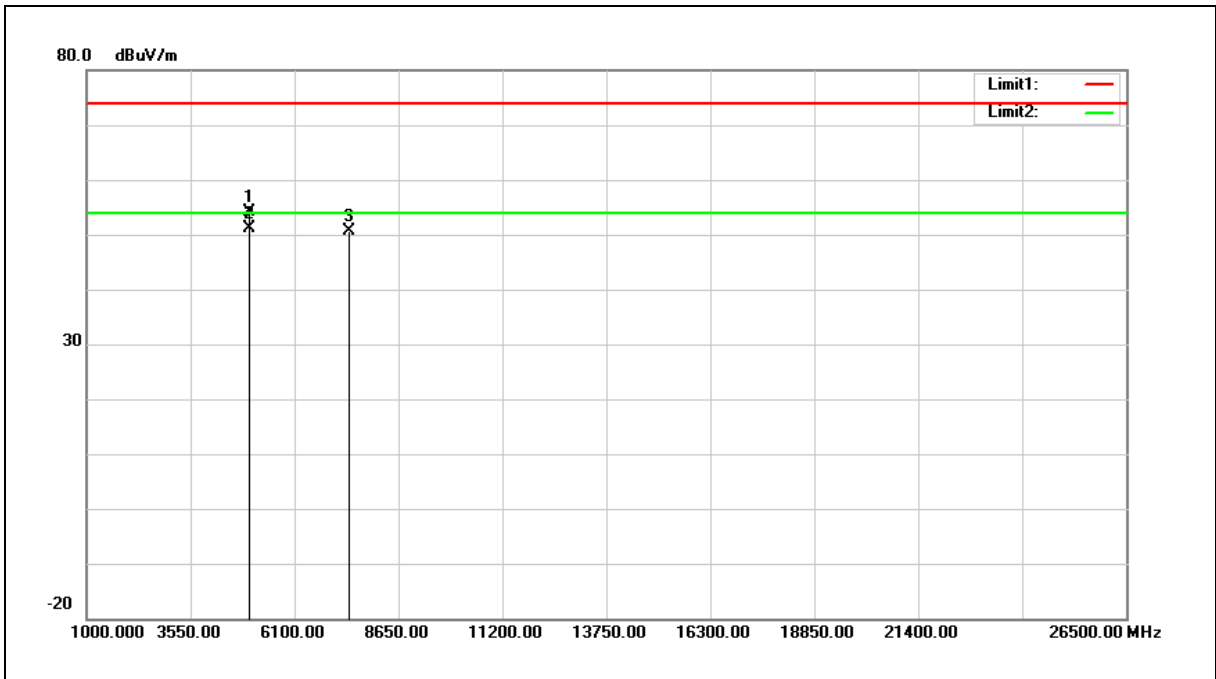

No.	Frequency (MHz)	Reading (dBuV)	Correct Factor (dB/m)	Result (dBuV/m)	Limit (dBuV/m)	Margin (dB)	Remark
1	4960.000	58.90	-4.89	54.01	74.00	-19.99	peak
2	4960.000	55.93	-4.89	51.04	54.00	-2.96	AVG
3	7440.000	50.46	0.06	50.52	74.00	-23.48	peak

Note:1.Result (dBuV/m) = Correct Factor (dB/m) + Reading(dBuV).

2.Correction factor (dB/m) = Antenna Factor (dB/m) + Cable loss (dB) – Pre-Amplifier gain (dB).

3.When the peak results are less than average limit, so not need to evaluate the average.



### Band Edge

Antenna Type: PCB Trace Antenna

Standard:	FCC Part 15.247	Test Distance:	3 m
Test item:	Band edge	Power:	DC 3.3 V
Frequency:	2402 MHz	Temp.(°C)/Hum.(%RH):	26(°C)/60 %RH
Mode:	Mode 2		
Ant.Polar.:	Horizontal		

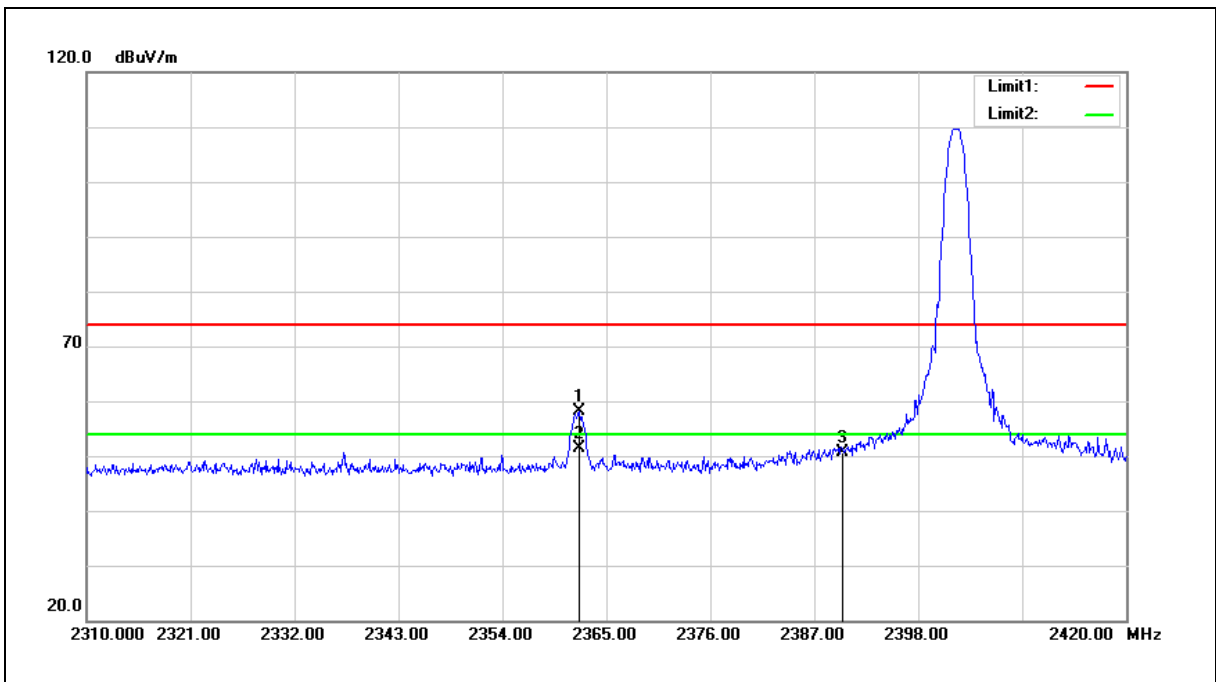

No.	Frequency (MHz)	Reading (dBuV)	Correct Factor (dB/m)	Result (dBuV/m)	Limit (dBuV/m)	Margin (dB)	Remark
1	2362.140	54.55	3.47	58.02	74.00	-15.98	peak
2	2362.140	47.91	3.47	51.38	54.00	-2.62	AVG
3	2390.000	47.00	3.53	50.53	74.00	-23.47	peak

Note:1.Result (dBuV/m) = Correct Factor (dB/m) + Reading(dBuV).

2.Correction factor (dB/m) = Antenna Factor (dB/m) + Cable loss (dB) – Pre-Amplifier gain (dB).

3.When the peak results are less than average limit, so not need to evaluate the average.



Standard:	FCC Part 15.247	Test Distance:	3 m
Test item:	Band edge	Power:	DC 3.3 V
Frequency:	2402 MHz	Temp.(°C)/Hum.(%RH):	26(°C)/60 %RH
Mode:	Mode 2		
Ant.Polar.:	Vertical		

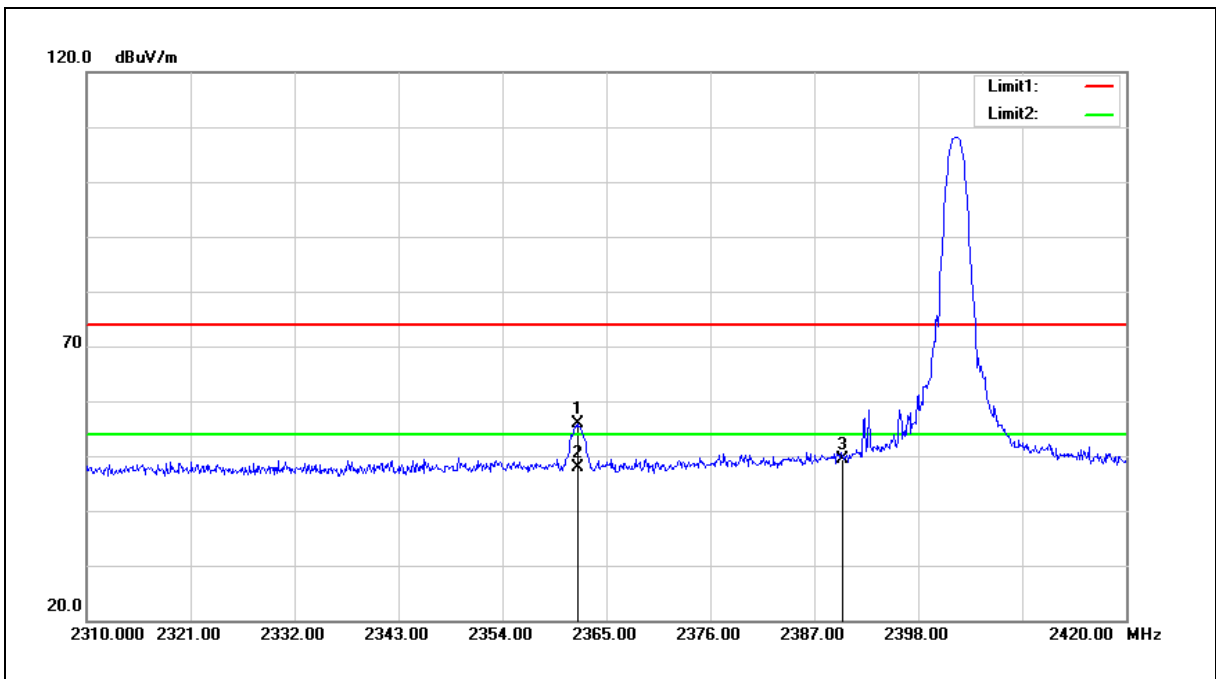

No.	Frequency (MHz)	Reading (dBuV)	Correct Factor (dB/m)	Result (dBuV/m)	Limit (dBuV/m)	Margin (dB)	Remark
1	2361.920	52.38	3.47	55.85	74.00	-18.15	peak
2	2361.920	44.40	3.47	47.87	54.00	-6.13	AVG
3	2390.000	45.79	3.53	49.32	74.00	-24.68	peak

Note:1.Result (dBuV/m) = Correct Factor (dB/m) + Reading(dBuV).

2.Correction factor (dB/m) = Antenna Factor (dB/m) + Cable loss (dB) – Pre-Amplifier gain (dB).

3.When the peak results are less than average limit, so not need to evaluate the average.



Standard:	FCC Part 15.247	Test Distance:	3 m
Test item:	Band edge	Power:	DC 3.3 V
Frequency:	2480 MHz	Temp.(°C)/Hum.(%RH):	26(°C)/60 %RH
Mode:	Mode 2		
Ant.Polar.:	Horizontal		

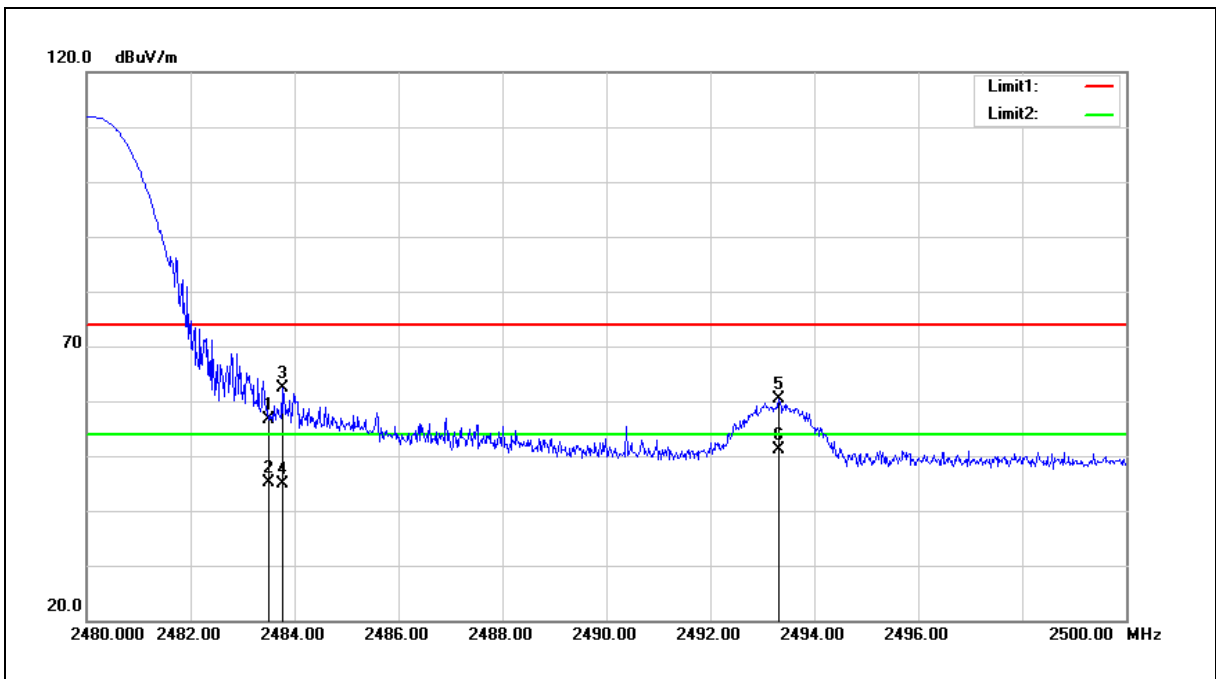

No.	Frequency (MHz)	Reading (dBuV)	Correct Factor (dB/m)	Result (dBuV/m)	Limit (dBuV/m)	Margin (dB)	Remark
1	2483.500	52.97	3.75	56.72	74.00	-17.28	peak
2	2483.500	41.49	3.75	45.24	54.00	-8.76	AVG
3	2483.760	58.54	3.75	62.29	74.00	-11.71	peak
4	2483.760	41.21	3.75	44.96	54.00	-9.04	AVG
5	2493.320	56.68	3.78	60.46	74.00	-13.54	peak
6	2493.320	47.36	3.78	51.14	54.00	-2.86	AVG

Note:1.Result (dBuV/m) = Correct Factor (dB/m) + Reading(dBuV).

2.Correction factor (dB/m) = Antenna Factor (dB/m) + Cable loss (dB) – Pre-Amplifier gain (dB).

3.When the peak results are less than average limit, so not need to evaluate the average.



Standard:	FCC Part 15.247	Test Distance:	3 m
Test item:	Band edge	Power:	DC 3.3 V
Frequency:	2480 MHz	Temp.(°C)/Hum.(%RH):	26(°C)/60 %RH
Mode:	Mode 2		
Ant.Polar.:	Vertical		

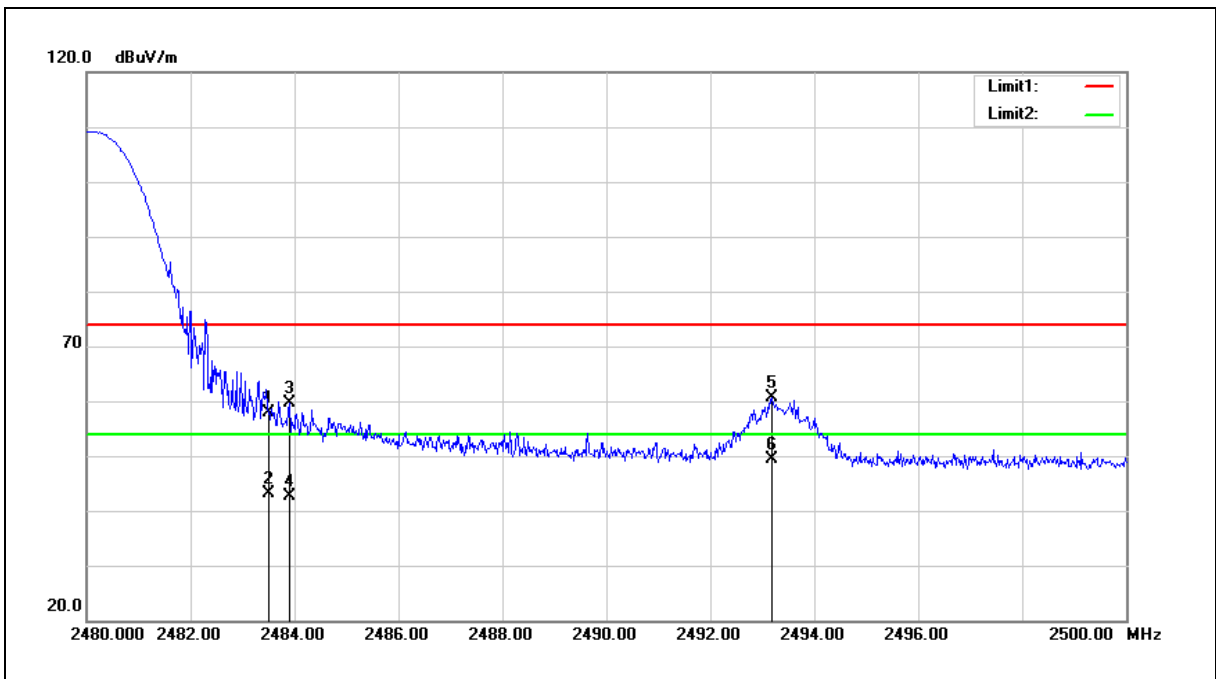

No.	Frequency (MHz)	Reading (dBuV)	Correct Factor (dB/m)	Result (dBuV/m)	Limit (dBuV/m)	Margin (dB)	Remark
1	2483.500	54.05	3.75	57.80	74.00	-16.20	peak
2	2483.500	39.30	3.75	43.05	54.00	-10.95	AVG
3	2483.900	55.86	3.75	59.61	74.00	-14.39	peak
4	2483.900	38.84	3.75	42.59	54.00	-11.41	AVG
5	2493.180	56.76	3.77	60.53	74.00	-13.47	peak
6	2493.180	45.55	3.77	49.32	54.00	-4.68	AVG

Note:1.Result (dBuV/m) = Correct Factor (dB/m) + Reading(dBuV).

2.Correction factor (dB/m) = Antenna Factor (dB/m) + Cable loss (dB) – Pre-Amplifier gain (dB).

3.When the peak results are less than average limit, so not need to evaluate the average.



Standard:	FCC Part 15.247	Test Distance:	3 m
Test item:	Band edge	Power:	DC 3.3 V
Frequency:	Hopping	Temp.(°C)/Hum.(%RH):	26(°C)/60 %RH
Mode:	Mode 2		
Ant.Polar.:	Horizontal		

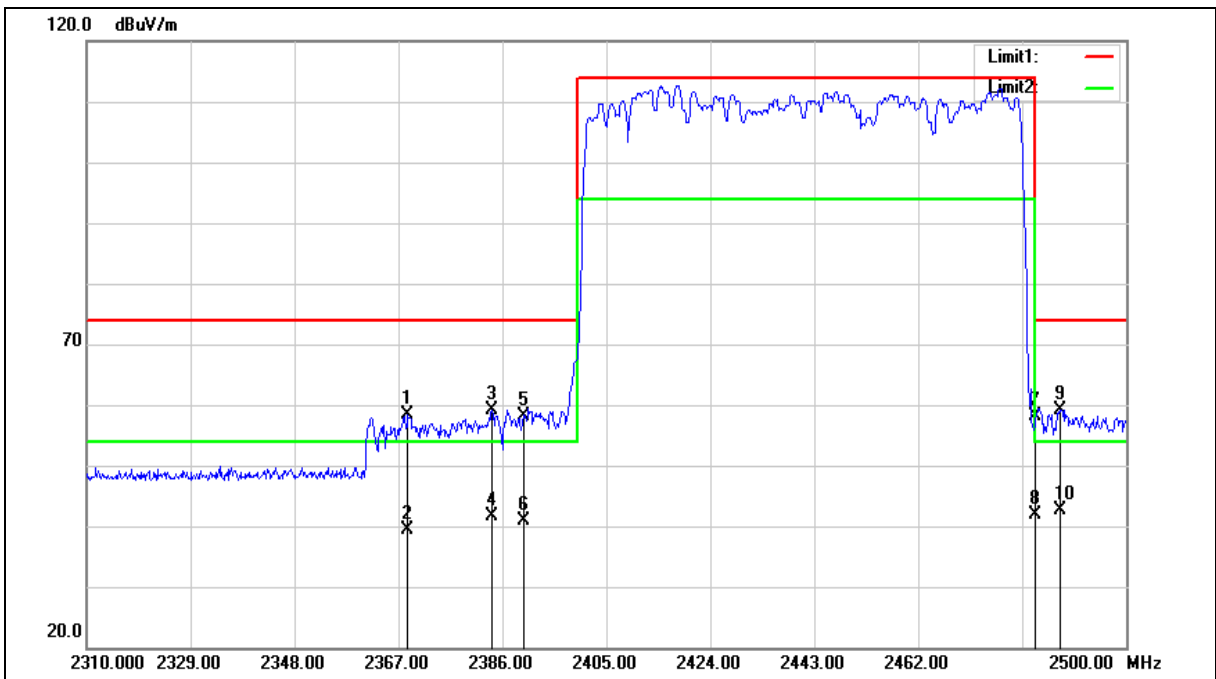



Standard:	FCC Part 15.247	Test Distance:	3 m
Test item:	Band edge	Power:	DC 3.3 V
Frequency:	Hopping	Temp.(°C)/Hum.(%RH):	26(°C)/60 %RH
Mode:	Mode 2		
Ant.Polar.:	Horizontal		

No.	Frequency (MHz)	Reading (dBuV)	Correct Factor (dB/m)	Result (dBuV/m)	Limit (dBuV/m)	Margin (dB)	Remark
1	2368.710	54.83	3.48	58.31	74.00	-15.69	peak
2	2368.710	35.90	3.48	39.38	54.00	-14.62	AVG
3	2384.100	55.54	3.52	59.06	74.00	-14.94	peak
4	2384.100	38.04	3.52	41.56	54.00	-12.44	AVG
5	2390.000	54.49	3.53	58.02	74.00	-15.98	peak
6	2390.000	37.31	3.53	40.84	54.00	-13.16	AVG
7	2483.500	54.47	3.75	58.22	74.00	-15.78	peak
8	2483.500	38.10	3.75	41.85	54.00	-12.15	AVG
9	2487.840	55.41	3.76	59.17	74.00	-14.83	peak
10	2487.840	38.98	3.76	42.74	54.00	-11.26	AVG

Note:1.Result (dBuV/m) = Correct Factor (dB/m) + Reading(dBuV).

2.Correction factor (dB/m) = Antenna Factor (dB/m) + Cable loss (dB) – Pre-Amplifier gain (dB).

3.When the peak results are less than average limit, so not need to evaluate the average.





Standard:	FCC Part 15.247	Test Distance:	3 m
Test item:	Band edge	Power:	DC 3.3 V
Frequency:	Hopping	Temp.(°C)/Hum.(%RH):	26(°C)/60 %RH
Mode:	Mode 2		
Ant.Polar.:	Vertical		

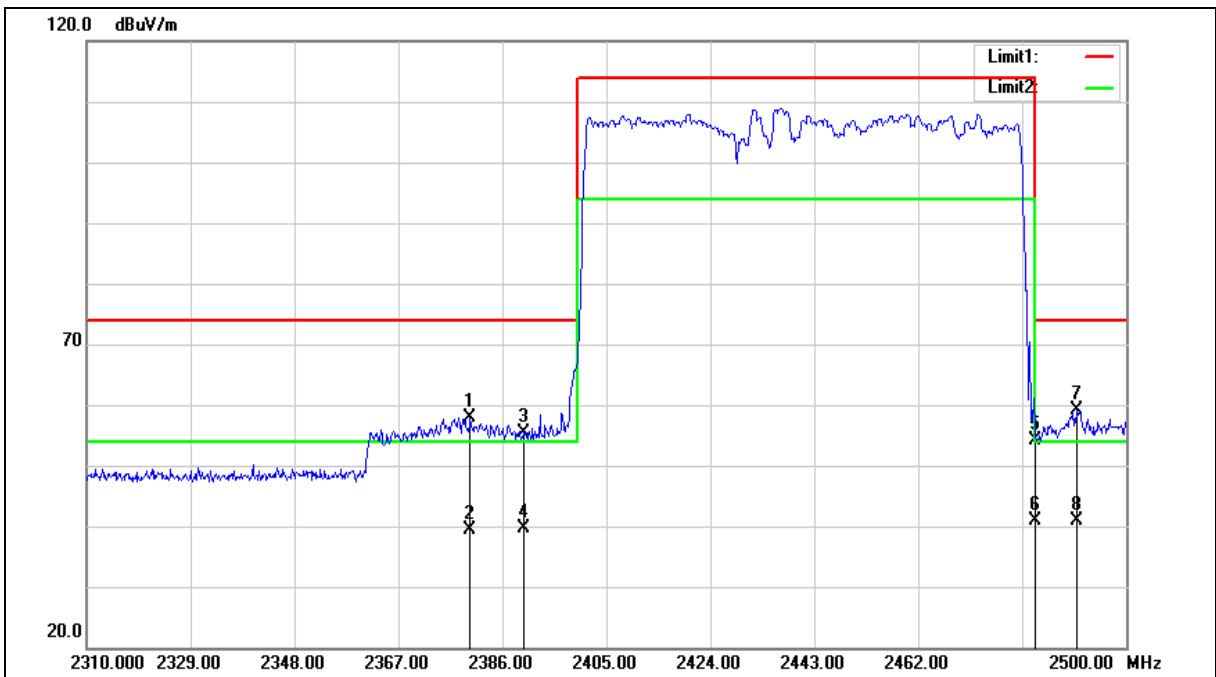



Standard:	FCC Part 15.247	Test Distance:	3 m
Test item:	Band edge	Power:	DC 3.3 V
Frequency:	Hopping	Temp.(°C)/Hum.(%RH):	26(°C)/60 %RH
Mode:	Mode 2		
Ant.Polar.:	Vertical		

No.	Frequency (MHz)	Reading (dBuV)	Correct Factor (dB/m)	Result (dBuV/m)	Limit (dBuV/m)	Margin (dB)	Remark
1	2380.110	54.36	3.51	57.87	74.00	-16.13	peak
2	2380.110	35.94	3.51	39.45	54.00	-14.55	AVG
3	2390.000	51.82	3.53	55.35	74.00	-18.65	peak
4	2390.000	36.13	3.53	39.66	54.00	-14.34	AVG
5	2483.500	50.39	3.75	54.14	74.00	-19.86	peak
6	2483.500	37.18	3.75	40.93	54.00	-13.07	AVG
7	2491.070	55.42	3.77	59.19	74.00	-14.81	peak
8	2491.070	37.12	3.77	40.89	54.00	-13.11	AVG

Note:1.Result (dBuV/m) = Correct Factor (dB/m) + Reading(dBuV).

2.Correction factor (dB/m) = Antenna Factor (dB/m) + Cable loss (dB) – Pre-Amplifier gain (dB).

3.When the peak results are less than average limit, so not need to evaluate the average.



Standard:	FCC Part 15.247	Test Distance:	3 m
Test item:	Band edge	Power:	DC 3.3 V
Frequency:	2402 MHz	Temp.(°C)/Hum.(%RH):	26(°C)/60 %RH
Mode:	Mode 4		
Ant.Polar.:	Horizontal		

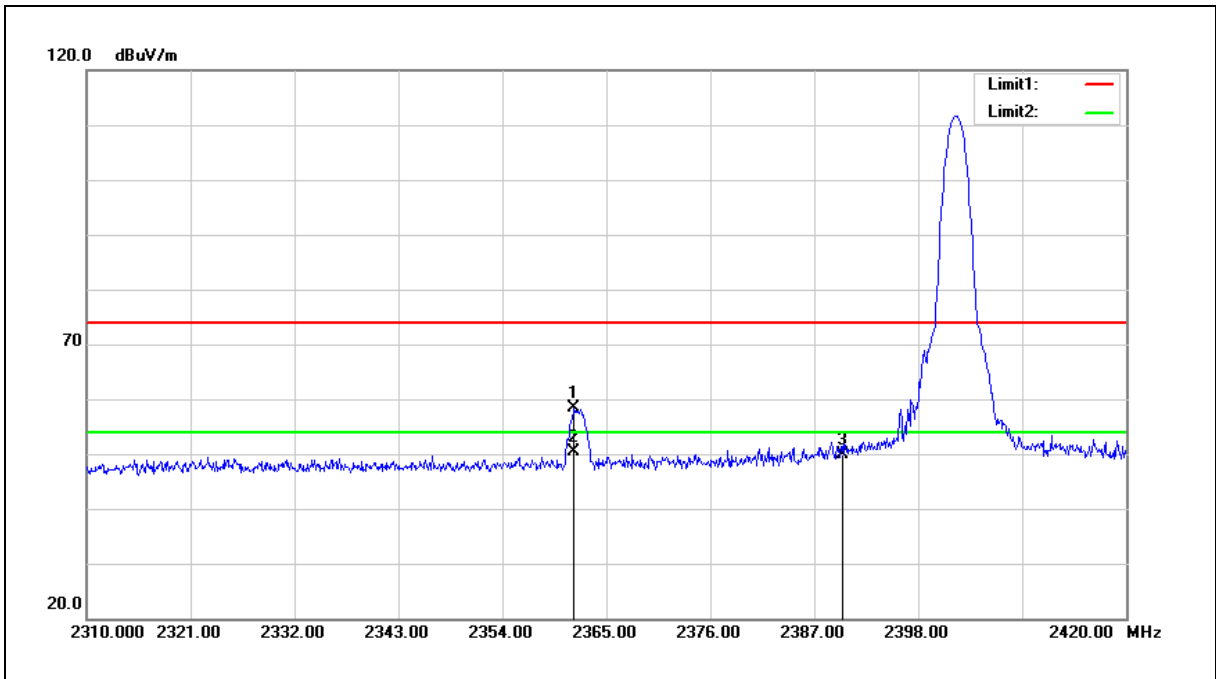

No.	Frequency (MHz)	Reading (dBuV)	Correct Factor (dB/m)	Result (dBuV/m)	Limit (dBuV/m)	Margin (dB)	Remark
1	2361.590	54.90	3.47	58.37	74.00	-15.63	peak
2	2361.590	47.03	3.47	50.50	54.00	-3.50	AVG
3	2390.000	46.39	3.53	49.92	74.00	-24.08	peak

Note:1.Result (dBuV/m) = Correct Factor (dB/m) + Reading(dBuV).

2.Correction factor (dB/m) = Antenna Factor (dB/m) + Cable loss (dB) – Pre-Amplifier gain (dB).

3.When the peak results are less than average limit, so not need to evaluate the average.



Standard:	FCC Part 15.247	Test Distance:	3 m
Test item:	Band edge	Power:	DC 3.3 V
Frequency:	2402 MHz	Temp.(°C)/Hum.(%RH):	26(°C)/60 %RH
Mode:	Mode 4		
Ant.Polar.:	Vertical		

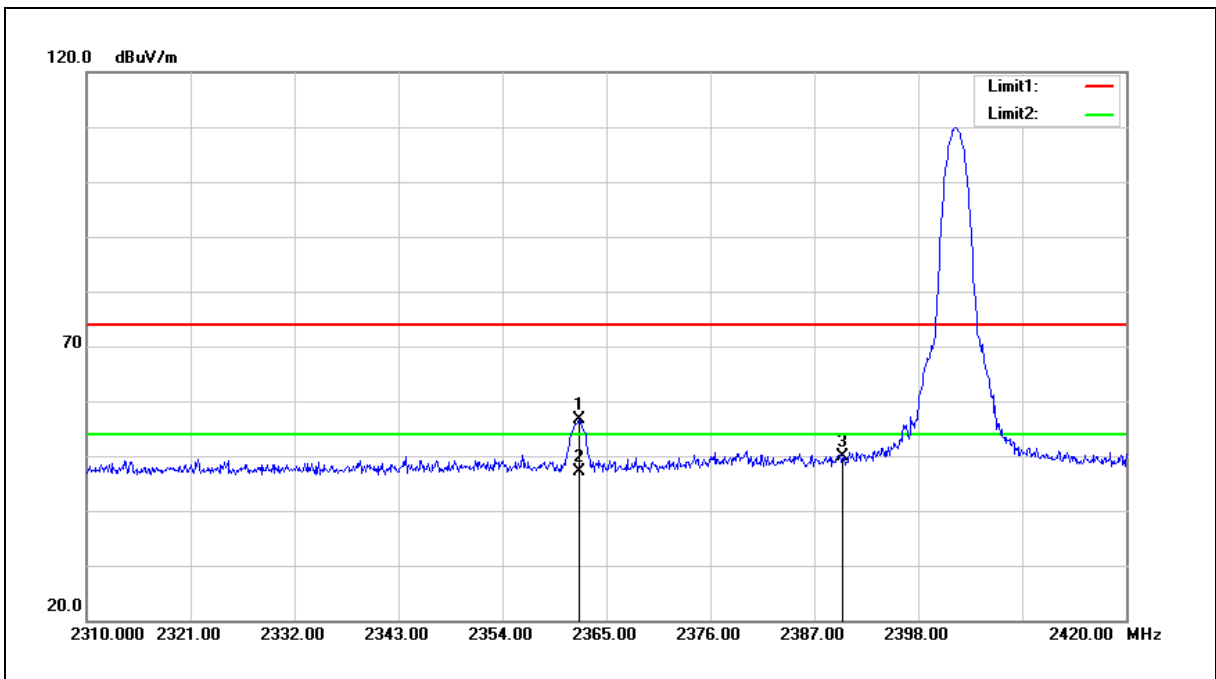

No.	Frequency (MHz)	Reading (dBuV)	Correct Factor (dB/m)	Result (dBuV/m)	Limit (dBuV/m)	Margin (dB)	Remark
1	2362.140	53.04	3.47	56.51	74.00	-17.49	peak
2	2362.140	43.68	3.47	47.15	54.00	-6.85	AVG
3	2390.000	46.24	3.53	49.77	74.00	-24.23	peak

Note:1.Result (dBuV/m) = Correct Factor (dB/m) + Reading(dBuV).

2.Correction factor (dB/m) = Antenna Factor (dB/m) + Cable loss (dB) – Pre-Amplifier gain (dB).

3.When the peak results are less than average limit, so not need to evaluate the average.



Standard:	FCC Part 15.247	Test Distance:	3 m
Test item:	Band edge	Power:	DC 3.3 V
Frequency:	2480 MHz	Temp.(°C)/Hum.(%RH):	26(°C)/60 %RH
Mode:	Mode 4		
Ant.Polar.:	Horizontal		

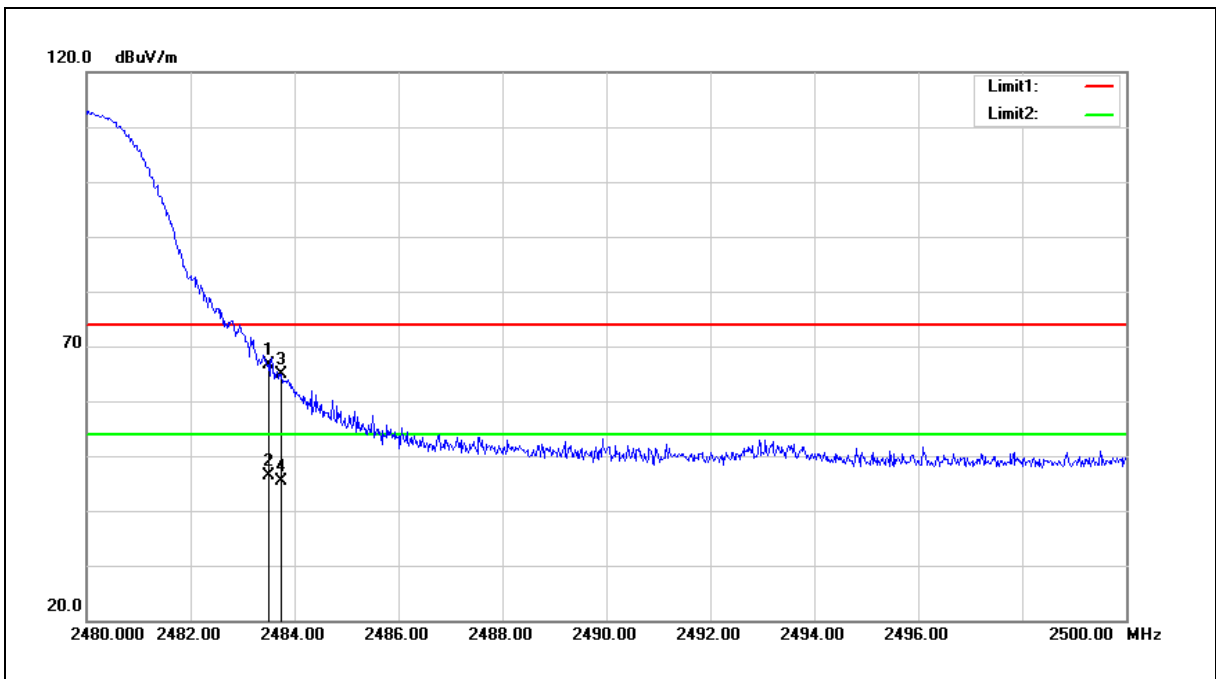

No.	Frequency (MHz)	Reading (dBuV)	Correct Factor (dB/m)	Result (dBuV/m)	Limit (dBuV/m)	Margin (dB)	Remark
1	2483.500	63.00	3.75	66.75	74.00	-7.25	peak
2	2483.500	42.61	3.75	46.36	54.00	-7.64	AVG
3	2483.740	61.13	3.75	64.88	74.00	-9.12	peak
4	2483.740	41.55	3.75	45.30	54.00	-8.70	AVG

Note:1.Result (dBuV/m) = Correct Factor (dB/m) + Reading(dBuV).

2.Correction factor (dB/m) = Antenna Factor (dB/m) + Cable loss (dB) – Pre-Amplifier gain (dB).

3.When the peak results are less than average limit, so not need to evaluate the average.



Standard:	FCC Part 15.247	Test Distance:	3 m
Test item:	Band edge	Power:	DC 3.3 V
Frequency:	2480 MHz	Temp.(°C)/Hum.(%RH):	26(°C)/60 %RH
Mode:	Mode 4		
Ant.Polar.:	Vertical		

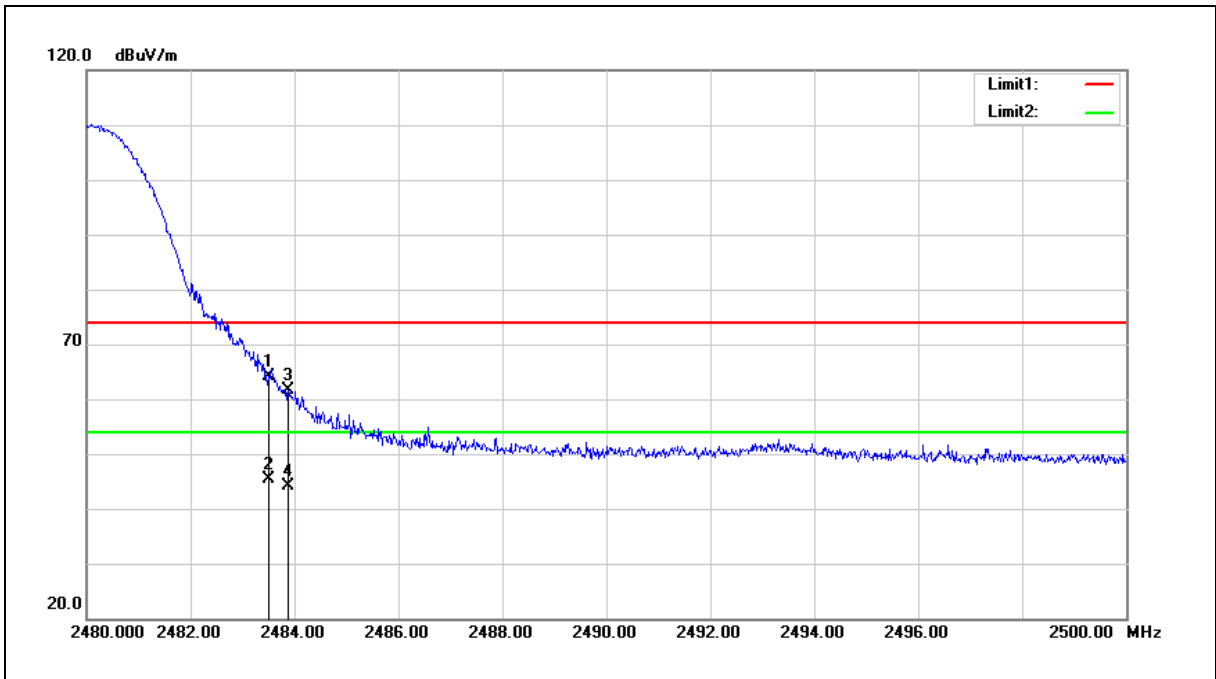

No.	Frequency (MHz)	Reading (dBuV)	Correct Factor (dB/m)	Result (dBuV/m)	Limit (dBuV/m)	Margin (dB)	Remark
1	2483.500	60.30	3.75	64.05	74.00	-9.95	peak
2	2483.500	41.75	3.75	45.50	54.00	-8.50	AVG
3	2483.880	57.85	3.75	61.60	74.00	-12.40	peak
4	2483.880	40.40	3.75	44.15	54.00	-9.85	AVG

- Note:1.Result (dBuV/m) = Correct Factor (dB/m) + Reading(dBuV).
- 2.Correction factor (dB/m) = Antenna Factor (dB/m) + Cable loss (dB) – Pre-Amplifier gain (dB).
- 3.When the peak results are less than average limit, so not need to evaluate the average.



Standard:	FCC Part 15.247	Test Distance:	3 m
Test item:	Band edge	Power:	DC 3.3 V
Frequency:	Hopping	Temp.(°C)/Hum.(%RH):	26(°C)/60 %RH
Mode:	Mode 4		
Ant.Polar.:	Horizontal		

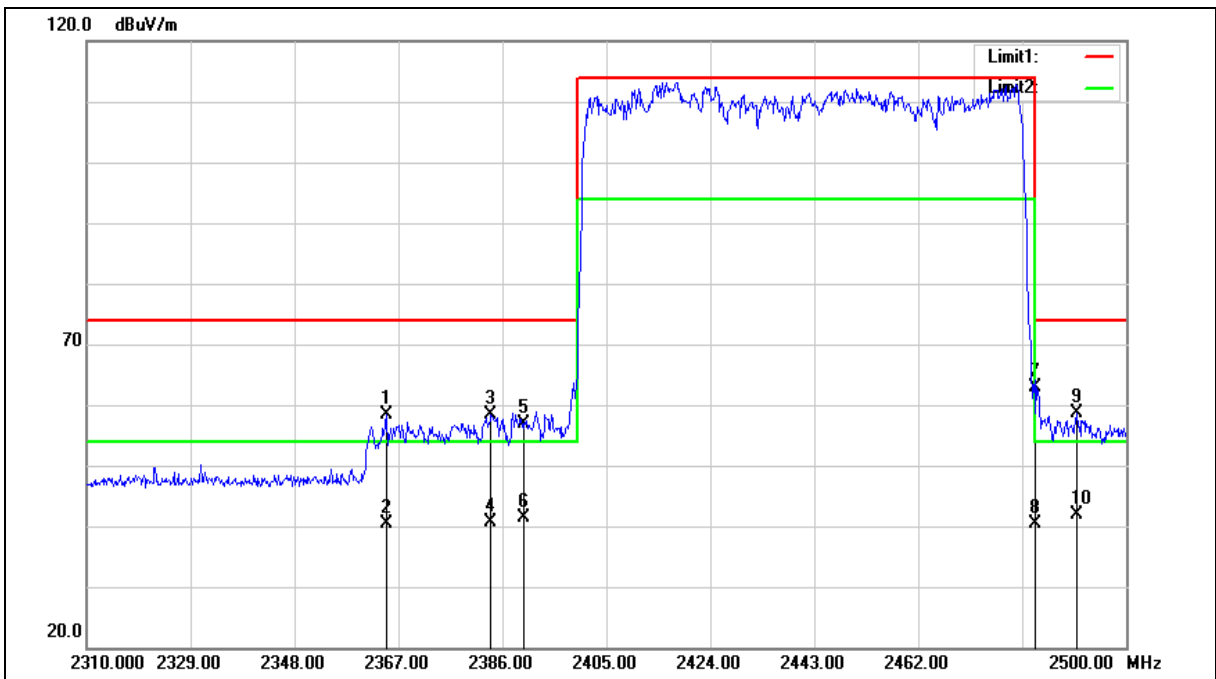



Standard:	FCC Part 15.247	Test Distance:	3 m
Test item:	Band edge	Power:	DC 3.3 V
Frequency:	Hopping	Temp.(°C)/Hum.(%RH):	26(°C)/60 %RH
Mode:	Mode 4		
Ant.Polar.:	Horizontal		

No.	Frequency (MHz)	Reading (dBuV)	Correct Factor (dB/m)	Result (dBuV/m)	Limit (dBuV/m)	Margin (dB)	Remark
1	2364.720	54.81	3.47	58.28	74.00	-15.72	peak
2	2364.720	36.83	3.47	40.30	54.00	-13.70	AVG
3	2383.910	54.89	3.51	58.40	74.00	-15.60	peak
4	2383.910	37.22	3.51	40.73	54.00	-13.27	AVG
5	2390.000	53.33	3.53	56.86	74.00	-17.14	peak
6	2390.000	37.75	3.53	41.28	54.00	-12.72	AVG
7	2483.500	59.11	3.75	62.86	74.00	-11.14	peak
8	2483.500	36.58	3.75	40.33	54.00	-13.67	AVG
9	2491.070	54.84	3.77	58.61	74.00	-15.39	peak
10	2491.070	38.16	3.77	41.93	54.00	-12.07	AVG

Note:1.Result (dBuV/m) = Correct Factor (dB/m) + Reading(dBuV).

2.Correction factor (dB/m) = Antenna Factor (dB/m) + Cable loss (dB) – Pre-Amplifier gain (dB).

3.When the peak results are less than average limit, so not need to evaluate the average.





Standard:	FCC Part 15.247	Test Distance:	3 m
Test item:	Band edge	Power:	DC 3.3 V
Frequency:	Hopping	Temp.(°C)/Hum.(%RH):	26(°C)/60 %RH
Mode:	Mode 4		
Ant.Polar.:	Vertical		

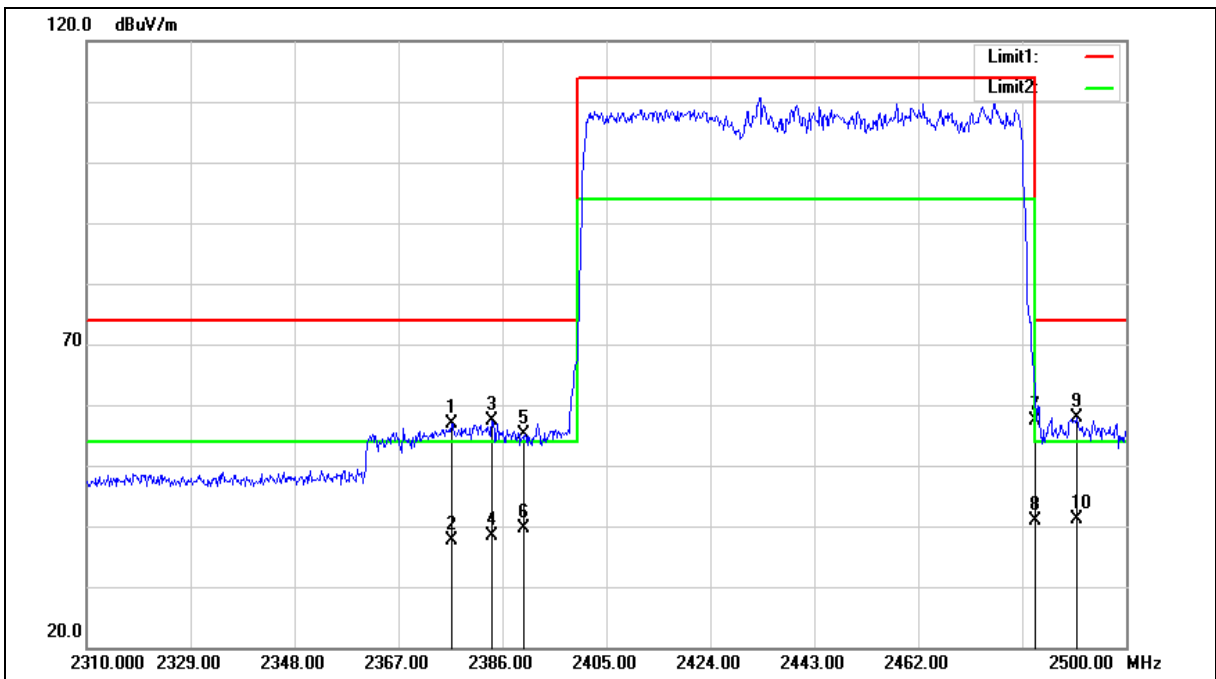



Standard:	FCC Part 15.247	Test Distance:	3 m
Test item:	Band edge	Power:	DC 3.3 V
Frequency:	Hopping	Temp.(°C)/Hum.(%RH):	26(°C)/60 %RH
Mode:	Mode 4		
Ant.Polar.:	Vertical		

No.	Frequency (MHz)	Reading (dBuV)	Correct Factor (dB/m)	Result (dBuV/m)	Limit (dBuV/m)	Margin (dB)	Remark
1	2376.690	53.33	3.50	56.83	74.00	-17.17	peak
2	2376.690	34.01	3.50	37.51	54.00	-16.49	AVG
3	2384.100	53.91	3.52	57.43	74.00	-16.57	peak
4	2384.100	34.86	3.52	38.38	54.00	-15.62	AVG
5	2390.000	51.50	3.53	55.03	74.00	-18.97	peak
6	2390.000	36.13	3.53	39.66	54.00	-14.34	AVG
7	2483.500	53.53	3.75	57.28	74.00	-16.72	peak
8	2483.500	37.20	3.75	40.95	54.00	-13.05	AVG
9	2490.880	54.05	3.77	57.82	74.00	-16.18	peak
10	2490.880	37.27	3.77	41.04	54.00	-12.96	AVG

Note:1.Result (dBuV/m) = Correct Factor (dB/m) + Reading(dBuV).

2.Correction factor (dB/m) = Antenna Factor (dB/m) + Cable loss (dB) – Pre-Amplifier gain (dB).

3.When the peak results are less than average limit, so not need to evaluate the average.



Antenna Type: Heavy Duty Screw Mount Antenna

Standard:	FCC Part 15.247	Test Distance:	3 m
Test item:	Band edge	Power:	DC 3.3 V
Frequency:	2402 MHz	Temp.(°C)/Hum.(%RH):	26(°C)/60 %RH
Mode:	Mode 2		
Ant.Polar.:	Horizontal		

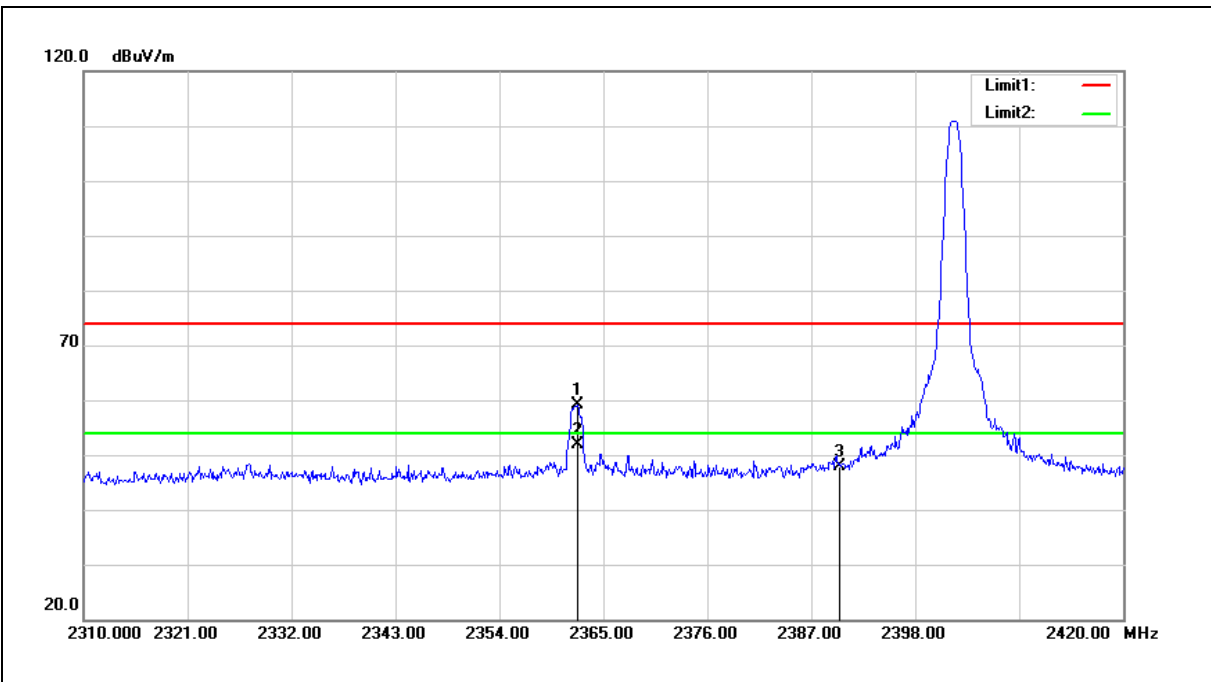

No.	Frequency (MHz)	Reading (dBuV)	Correct Factor (dB/m)	Result (dBuV/m)	Limit (dBuV/m)	Margin (dB)	Remark
1	2362.250	68.81	-9.73	59.08	74.00	-14.92	peak
2	2362.250	61.69	-9.73	51.96	54.00	-2.04	AVG
3	2390.000	57.54	-9.62	47.92	74.00	-26.08	peak

Note:1.Result (dBuV/m) = Correct Factor (dB/m) + Reading(dBuV).

2.Correction factor (dB/m) = Antenna Factor (dB/m) + Cable loss (dB) – Pre-Amplifier gain (dB).

3.When the peak results are less than average limit, so not need to evaluate the average.



Standard:	FCC Part 15.247	Test Distance:	3 m
Test item:	Band edge	Power:	DC 3.3 V
Frequency:	2402 MHz	Temp.(°C)/Hum.(%RH):	26(°C)/60 %RH
Mode:	Mode 2		
Ant.Polar.:	Vertical		

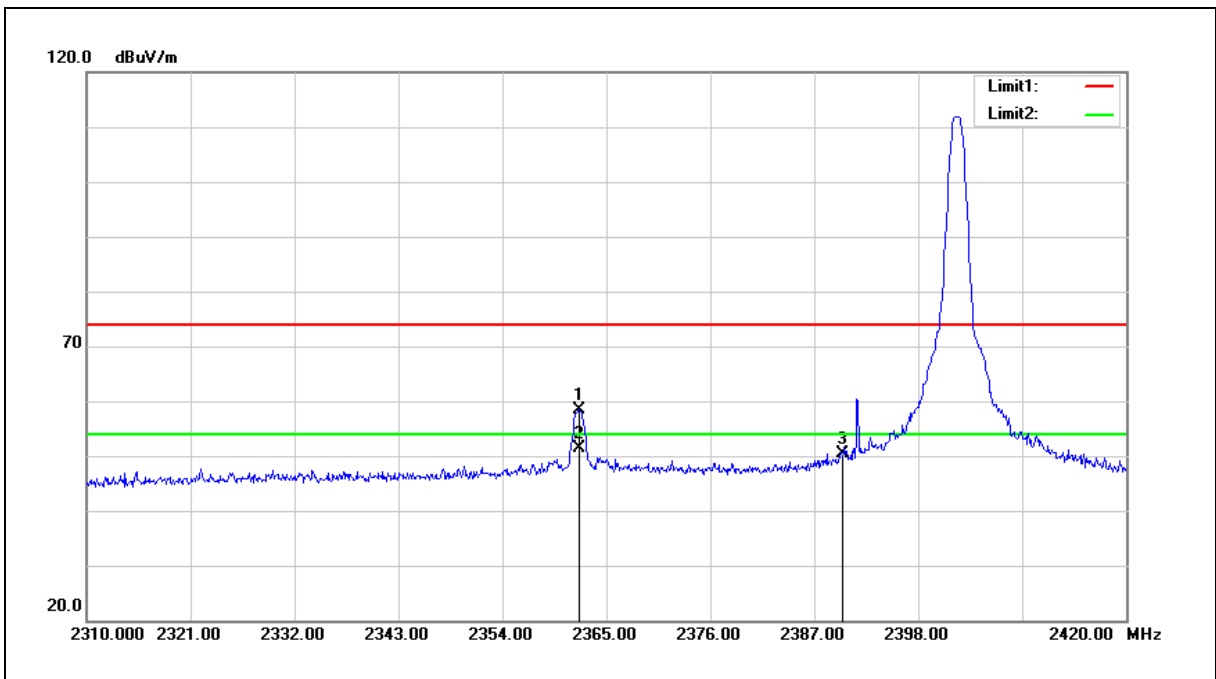

No.	Frequency (MHz)	Reading (dBuV)	Correct Factor (dB/m)	Result (dBuV/m)	Limit (dBuV/m)	Margin (dB)	Remark
1	2362.140	68.07	-9.73	58.34	74.00	-15.66	peak
2	2362.140	61.07	-9.73	51.34	54.00	-2.66	AVG
3	2390.000	60.10	-9.62	50.48	74.00	-23.52	peak

Note:1.Result (dBuV/m) = Correct Factor (dB/m) + Reading(dBuV).

2.Correction factor (dB/m) = Antenna Factor (dB/m) + Cable loss (dB) – Pre-Amplifier gain (dB).

3.When the peak results are less than average limit, so not need to evaluate the average.



Standard:	FCC Part 15.247	Test Distance:	3 m
Test item:	Band edge	Power:	DC 3.3 V
Frequency:	2480 MHz	Temp.(°C)/Hum.(%RH):	26(°C)/60 %RH
Mode:	Mode 2		
Ant.Polar.:	Horizontal		

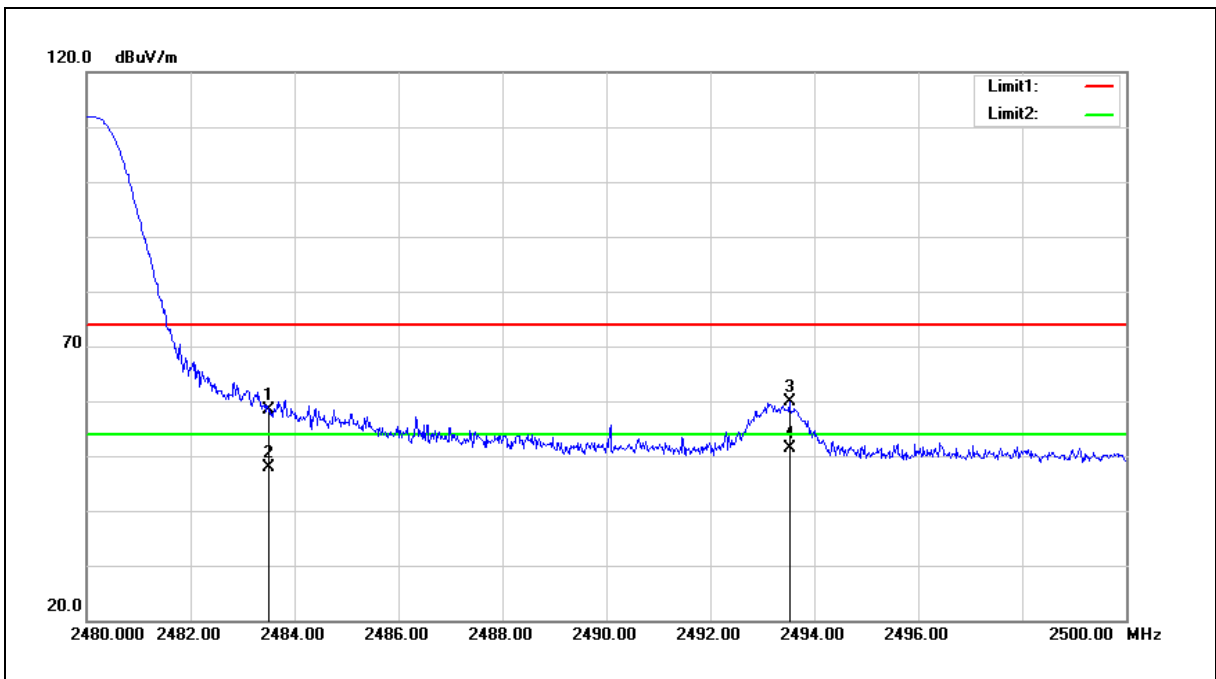

No.	Frequency (MHz)	Reading (dBuV)	Correct Factor (dB/m)	Result (dBuV/m)	Limit (dBuV/m)	Margin (dB)	Remark
1	2483.500	67.87	-9.37	58.50	74.00	-15.50	peak
2	2483.500	57.17	-9.37	47.80	54.00	-6.20	AVG
3	2493.520	69.29	-9.35	59.94	74.00	-14.06	peak
4	2493.520	60.67	-9.35	51.32	54.00	-2.68	AVG

Note:1.Result (dBuV/m) = Correct Factor (dB/m) + Reading(dBuV).

2.Correction factor (dB/m) = Antenna Factor (dB/m) + Cable loss (dB) – Pre-Amplifier gain (dB).

3.When the peak results are less than average limit, so not need to evaluate the average.



Standard:	FCC Part 15.247	Test Distance:	3 m
Test item:	Band edge	Power:	DC 3.3 V
Frequency:	2480 MHz	Temp.(°C)/Hum.(%RH):	26(°C)/60 %RH
Mode:	Mode 2		
Ant.Polar.:	Vertical		

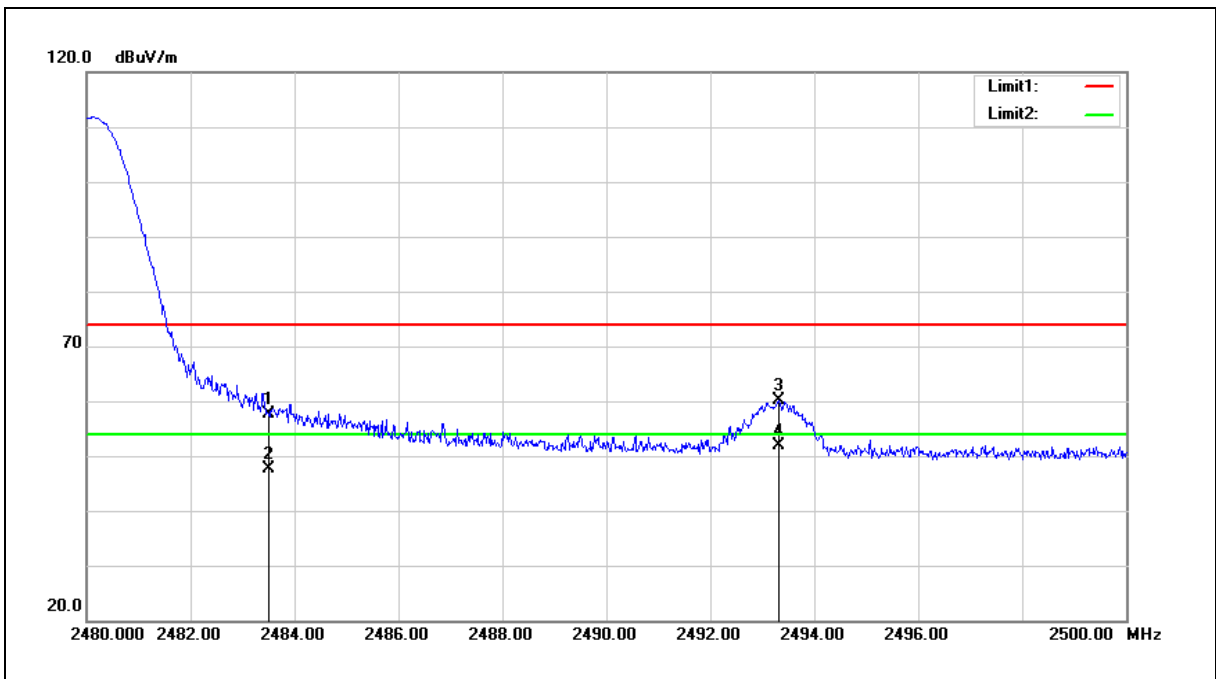

No.	Frequency (MHz)	Reading (dBuV)	Correct Factor (dB/m)	Result (dBuV/m)	Limit (dBuV/m)	Margin (dB)	Remark
1	2483.500	66.96	-9.37	57.59	74.00	-16.41	peak
2	2483.500	57.04	-9.37	47.67	54.00	-6.33	AVG
3	2493.320	69.54	-9.35	60.19	74.00	-13.81	peak
4	2493.320	61.16	-9.35	51.81	54.00	-2.19	AVG

Note:1.Result (dBuV/m) = Correct Factor (dB/m) + Reading(dBuV).

2.Correction factor (dB/m) = Antenna Factor (dB/m) + Cable loss (dB) – Pre-Amplifier gain (dB).

3.When the peak results are less than average limit, so not need to evaluate the average.



Standard:	FCC Part 15.247	Test Distance:	3 m
Test item:	Band edge	Power:	DC 3.3 V
Frequency:	Hopping	Temp.(°C)/Hum.(%RH):	26(°C)/60 %RH
Mode:	Mode 2		
Ant.Polar.:	Horizontal		

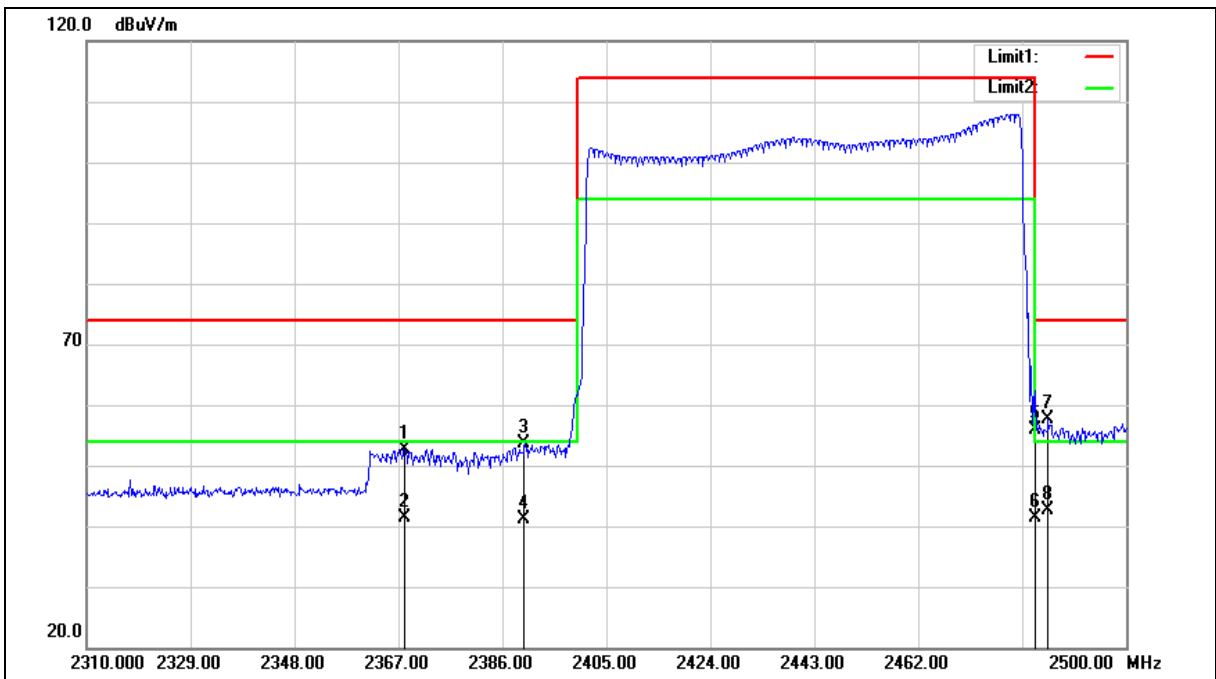



Standard:	FCC Part 15.247	Test Distance:	3 m
Test item:	Band edge	Power:	DC 3.3 V
Frequency:	Hopping	Temp.(°C)/Hum.(%RH):	26(°C)/60 %RH
Mode:	Mode 2		
Ant.Polar.:	Horizontal		

No.	Frequency (MHz)	Reading (dBuV)	Correct Factor (dB/m)	Result (dBuV/m)	Limit (dBuV/m)	Margin (dB)	Remark
1	2368.140	62.40	-9.71	52.69	74.00	-21.31	peak
2	2368.140	51.19	-9.71	41.48	54.00	-12.52	AVG
3	2390.000	63.16	-9.62	53.54	74.00	-20.46	peak
4	2390.000	50.82	-9.62	41.20	54.00	-12.80	AVG
5	2483.500	65.24	-9.37	55.87	74.00	-18.13	peak
6	2483.500	50.63	-9.37	41.26	54.00	-12.74	AVG
7	2485.750	66.88	-9.37	57.51	74.00	-16.49	peak
8	2485.750	52.05	-9.37	42.68	54.00	-11.32	AVG

Note:1.Result (dBuV/m) = Correct Factor (dB/m) + Reading(dBuV).

2.Correction factor (dB/m) = Antenna Factor (dB/m) + Cable loss (dB) – Pre-Amplifier gain (dB).

3.When the peak results are less than average limit, so not need to evaluate the average.





Standard:	FCC Part 15.247	Test Distance:	3 m
Test item:	Band edge	Power:	DC 3.3 V
Frequency:	Hopping	Temp.(°C)/Hum.(%RH):	26(°C)/60 %RH
Mode:	Mode 2		
Ant.Polar.:	Vertical		

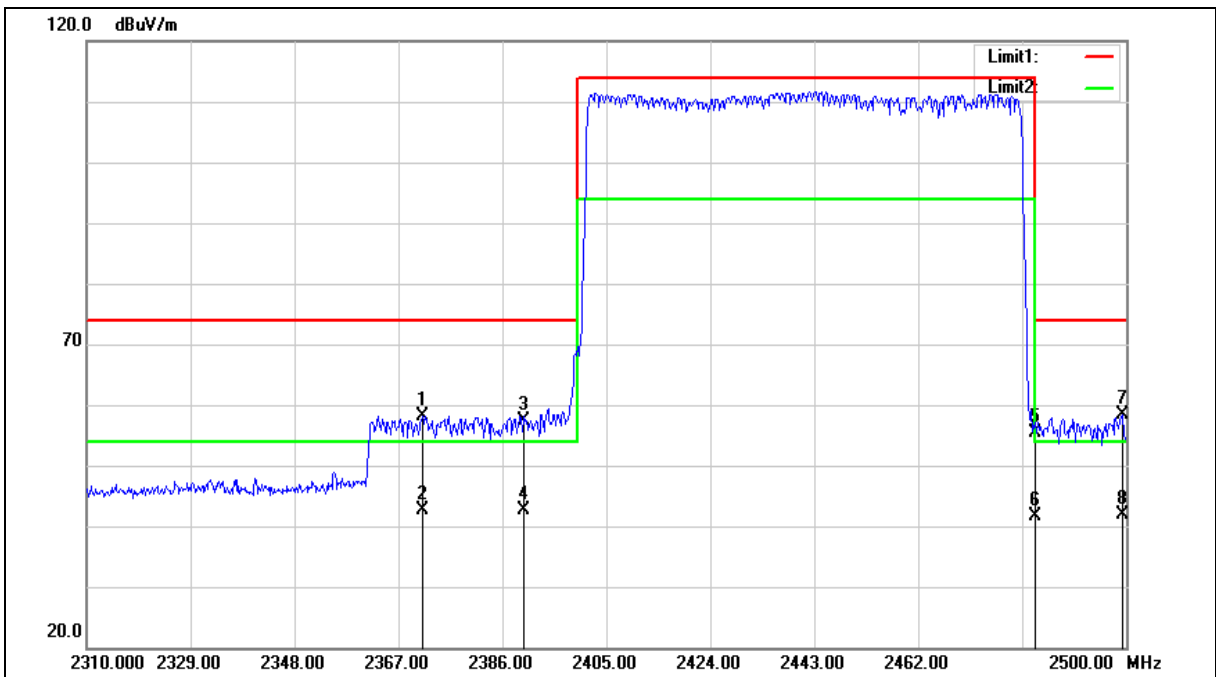



Standard:	FCC Part 15.247	Test Distance:	3 m
Test item:	Band edge	Power:	DC 3.3 V
Frequency:	Hopping	Temp.(°C)/Hum.(%RH):	26(°C)/60 %RH
Mode:	Mode 2		
Ant.Polar.:	Vertical		

No.	Frequency (MHz)	Reading (dBuV)	Correct Factor (dB/m)	Result (dBuV/m)	Limit (dBuV/m)	Margin (dB)	Remark
1	2371.370	67.87	-9.69	58.18	74.00	-15.82	peak
2	2371.370	52.37	-9.69	42.68	54.00	-11.32	AVG
3	2390.000	67.06	-9.62	57.44	74.00	-16.56	peak
4	2390.000	52.26	-9.62	42.64	54.00	-11.36	AVG
5	2483.500	64.72	-9.37	55.35	74.00	-18.65	peak
6	2483.500	50.97	-9.37	41.60	54.00	-12.40	AVG
7	2499.430	67.68	-9.33	58.35	74.00	-15.65	peak
8	2499.430	51.24	-9.33	41.91	54.00	-12.09	AVG

Note:1.Result (dBuV/m) = Correct Factor (dB/m) + Reading(dBuV).

2.Correction factor (dB/m) = Antenna Factor (dB/m) + Cable loss (dB) – Pre-Amplifier gain (dB).

3.When the peak results are less than average limit, so not need to evaluate the average.



Standard:	FCC Part 15.247	Test Distance:	3 m
Test item:	Band edge	Power:	DC 3.3 V
Frequency:	2402 MHz	Temp.(°C)/Hum.(%RH):	26(°C)/60 %RH
Mode:	Mode 4		
Ant.Polar.:	Horizontal		

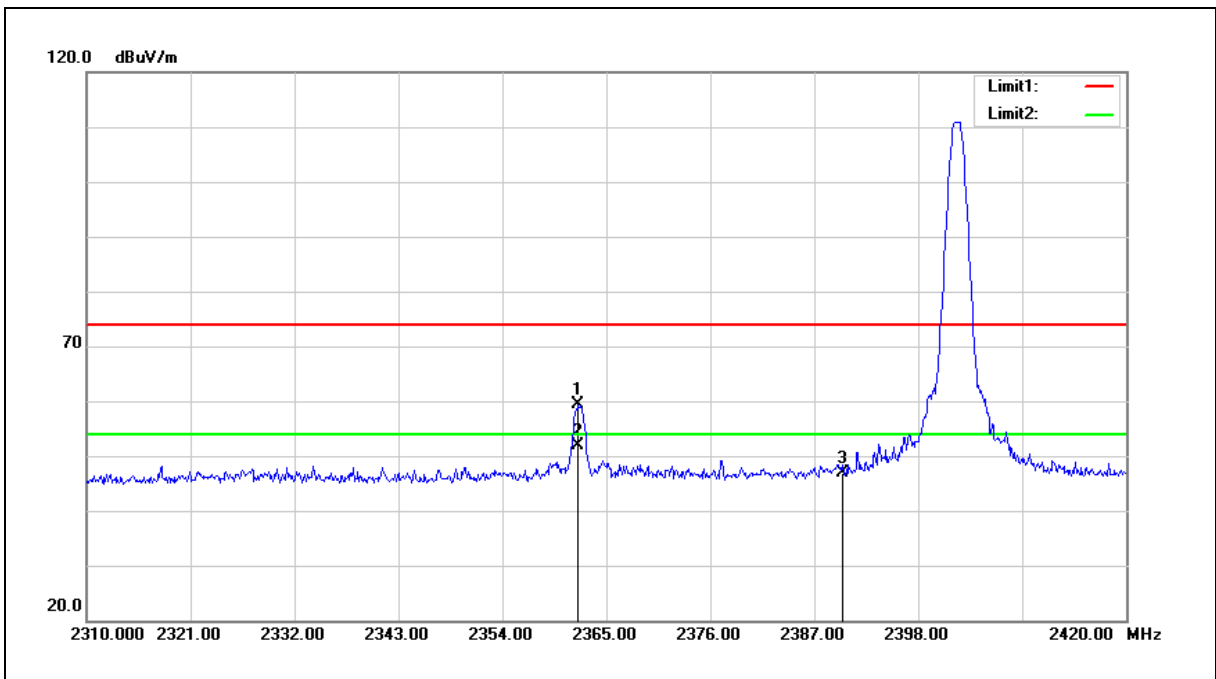

No.	Frequency (MHz)	Reading (dBuV)	Correct Factor (dB/m)	Result (dBuV/m)	Limit (dBuV/m)	Margin (dB)	Remark
1	2362.030	69.07	-9.73	59.34	74.00	-14.66	peak
2	2362.030	61.69	-9.73	51.96	54.00	-2.04	AVG
3	2390.000	56.61	-9.62	46.99	74.00	-27.01	peak

Note:1.Result (dBuV/m) = Correct Factor (dB/m) + Reading(dBuV).

2.Correction factor (dB/m) = Antenna Factor (dB/m) + Cable loss (dB) – Pre-Amplifier gain (dB).

3.When the peak results are less than average limit, so not need to evaluate the average.



Standard:	FCC Part 15.247	Test Distance:	3 m
Test item:	Band edge	Power:	DC 3.3 V
Frequency:	2402 MHz	Temp.(°C)/Hum.(%RH):	26(°C)/60 %RH
Mode:	Mode 4		
Ant.Polar.:	Vertical		

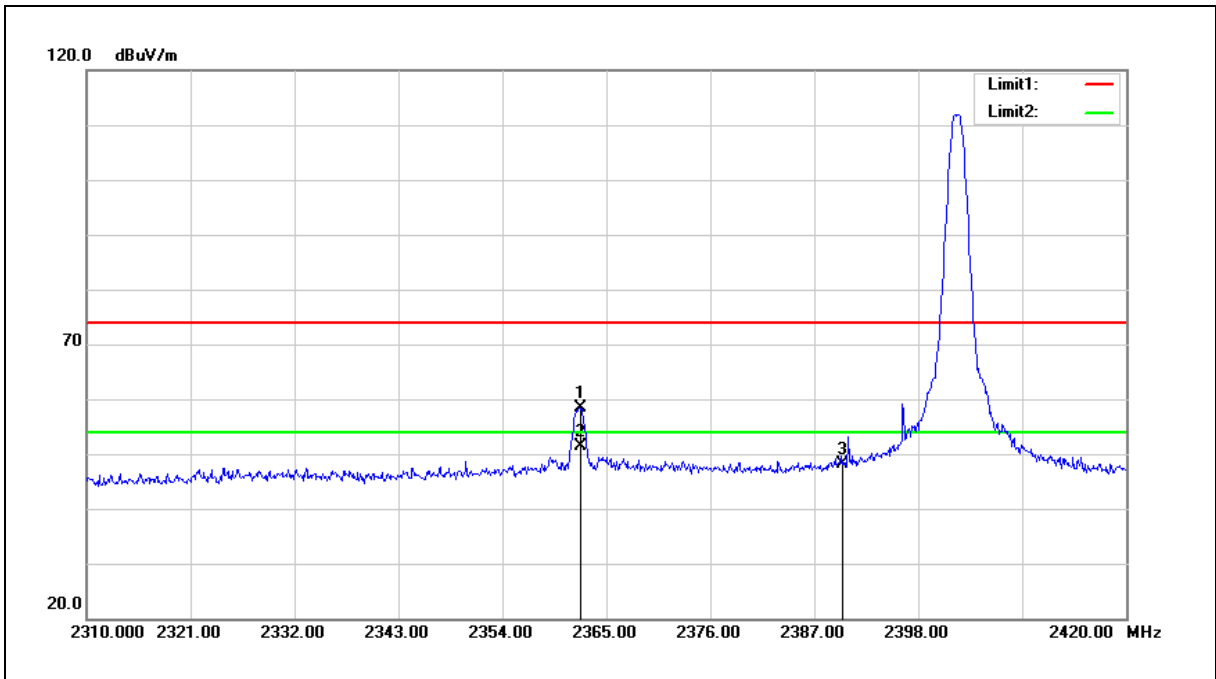

No.	Frequency (MHz)	Reading (dBuV)	Correct Factor (dB/m)	Result (dBuV/m)	Limit (dBuV/m)	Margin (dB)	Remark
1	2362.250	68.03	-9.73	58.30	74.00	-15.70	peak
2	2362.250	61.09	-9.73	51.36	54.00	-2.64	AVG
3	2390.000	57.63	-9.62	48.01	74.00	-25.99	peak

Note:1.Result (dBuV/m) = Correct Factor (dB/m) + Reading(dBuV).

2.Correction factor (dB/m) = Antenna Factor (dB/m) + Cable loss (dB) – Pre-Amplifier gain (dB).

3.When the peak results are less than average limit, so not need to evaluate the average.



Standard:	FCC Part 15.247	Test Distance:	3 m
Test item:	Band edge	Power:	DC 3.3 V
Frequency:	2480 MHz	Temp.(°C)/Hum.(%RH):	26(°C)/60 %RH
Mode:	Mode 4		
Ant.Polar.:	Horizontal		

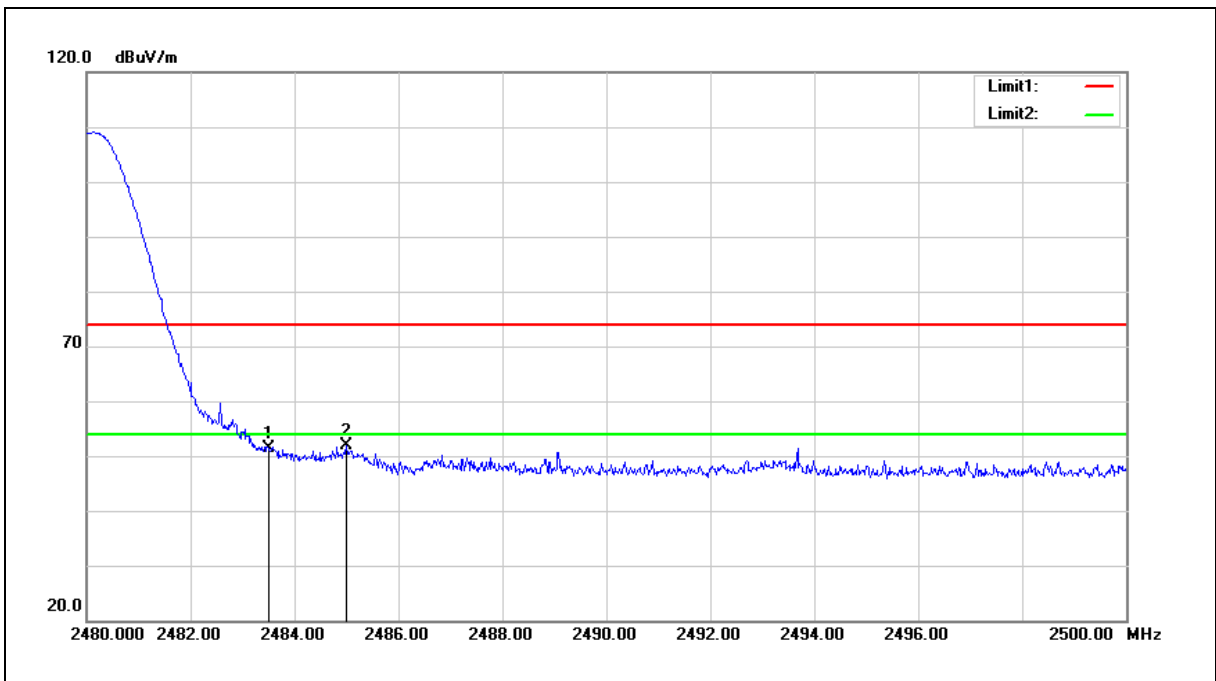

No.	Frequency (MHz)	Reading (dBuV)	Correct Factor (dB/m)	Result (dBuV/m)	Limit (dBuV/m)	Margin (dB)	Remark
1	2483.500	60.79	-9.37	51.42	74.00	-22.58	peak
2	2485.000	61.17	-9.37	51.80	74.00	-22.20	peak

Note:1.Result (dBuV/m) = Correct Factor (dB/m) + Reading(dBuV).

2.Correction factor (dB/m) = Antenna Factor (dB/m) + Cable loss (dB) – Pre-Amplifier gain (dB).

3.When the peak results are less than average limit, so not need to evaluate the average.



Standard:	FCC Part 15.247	Test Distance:	3 m
Test item:	Band edge	Power:	DC 3.3 V
Frequency:	2480 MHz	Temp.(°C)/Hum.(%RH):	26(°C)/60 %RH
Mode:	Mode 4		
Ant.Polar.:	Vertical		

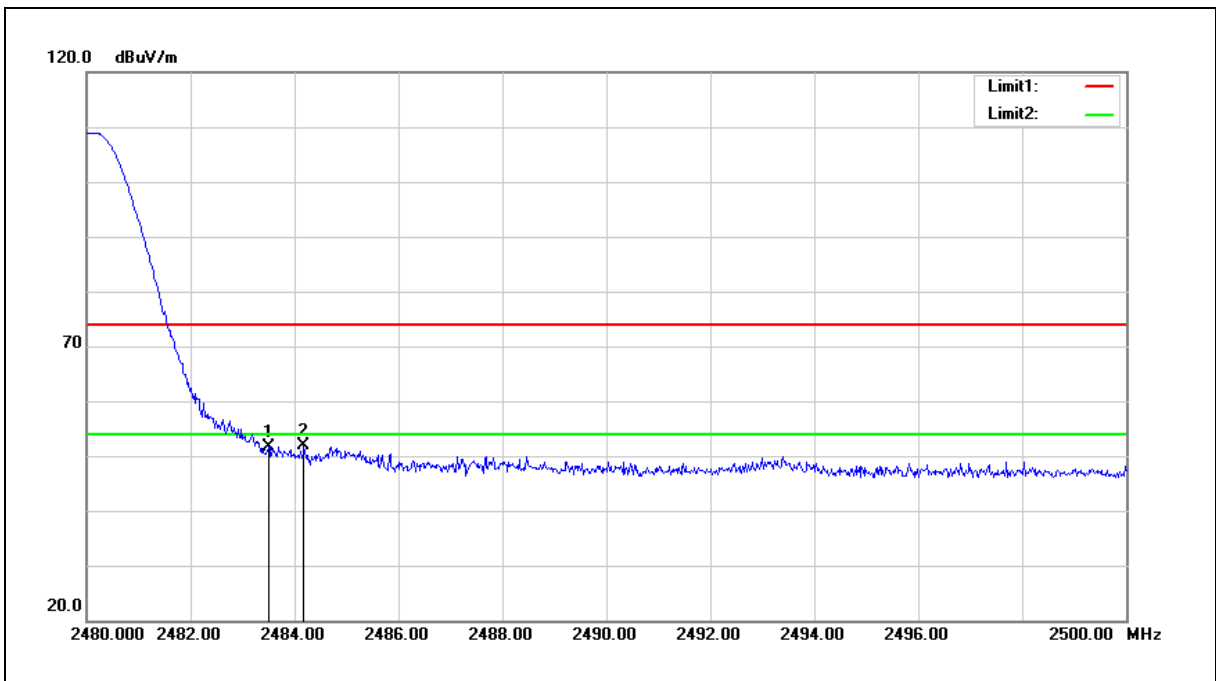

No.	Frequency (MHz)	Reading (dBuV)	Correct Factor (dB/m)	Result (dBuV/m)	Limit (dBuV/m)	Margin (dB)	Remark
1	2483.500	61.06	-9.37	51.69	74.00	-22.31	peak
2	2484.180	61.34	-9.37	51.97	74.00	-22.03	peak

Note:1.Result (dBuV/m) = Correct Factor (dB/m) + Reading(dBuV).

2.Correction factor (dB/m) = Antenna Factor (dB/m) + Cable loss (dB) – Pre-Amplifier gain (dB).

3.When the peak results are less than average limit, so not need to evaluate the average.



Standard:	FCC Part 15.247	Test Distance:	3 m
Test item:	Band edge	Power:	DC 3.3 V
Frequency:	Hopping	Temp.(°C)/Hum.(%RH):	26(°C)/60 %RH
Mode:	Mode 4		
Ant.Polar.:	Horizontal		

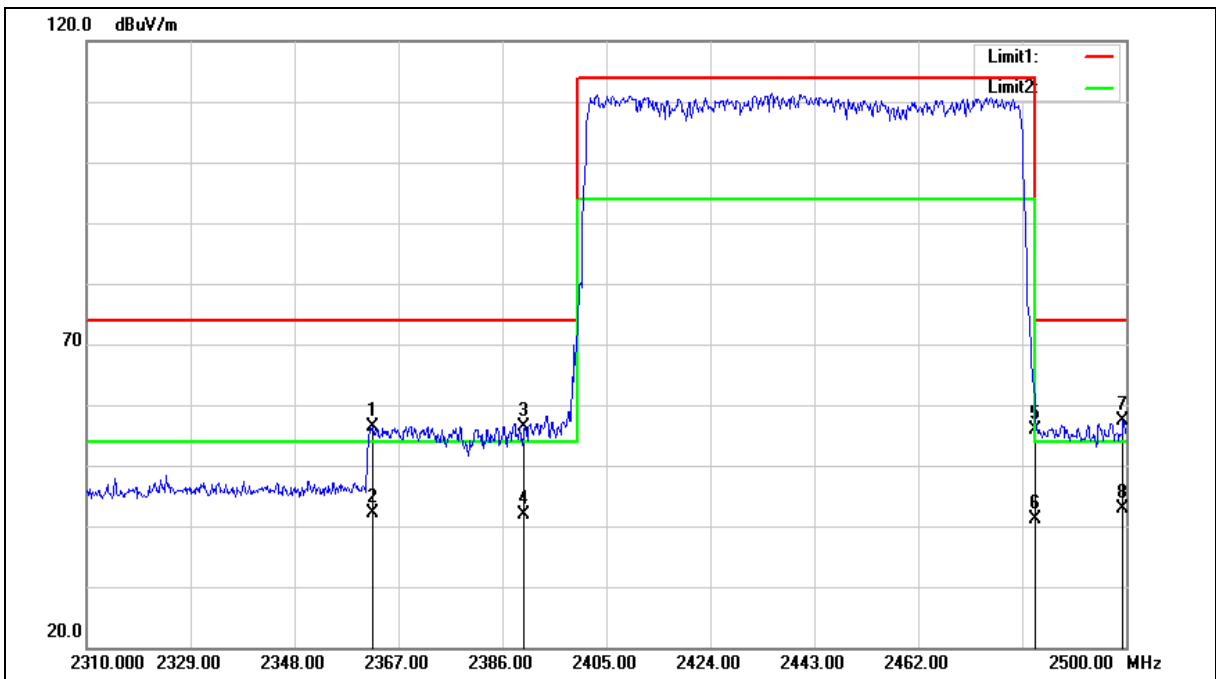



Standard:	FCC Part 15.247	Test Distance:	3 m
Test item:	Band edge	Power:	DC 3.3 V
Frequency:	Hopping	Temp.(°C)/Hum.(%RH):	26(°C)/60 %RH
Mode:	Mode 4		
Ant.Polar.:	Horizontal		

No.	Frequency (MHz)	Reading (dBuV)	Correct Factor (dB/m)	Result (dBuV/m)	Limit (dBuV/m)	Margin (dB)	Remark
1	2362.250	66.22	-9.73	56.49	74.00	-17.51	peak
2	2362.250	51.88	-9.73	42.15	54.00	-11.85	AVG
3	2390.000	65.89	-9.62	56.27	74.00	-17.73	peak
4	2390.000	51.38	-9.62	41.76	54.00	-12.24	AVG
5	2483.500	65.32	-9.37	55.95	74.00	-18.05	peak
6	2483.500	50.43	-9.37	41.06	54.00	-12.94	AVG
7	2499.430	66.73	-9.33	57.40	74.00	-16.60	peak
8	2499.430	52.27	-9.33	42.94	54.00	-11.06	AVG

Note:1.Result (dBuV/m) = Correct Factor (dB/m) + Reading(dBuV).

2.Correction factor (dB/m) = Antenna Factor (dB/m) + Cable loss (dB) – Pre-Amplifier gain (dB).

3.When the peak results are less than average limit, so not need to evaluate the average.





Standard:	FCC Part 15.247	Test Distance:	3 m
Test item:	Band edge	Power:	DC 3.3 V
Frequency:	Hopping	Temp.(°C)/Hum.(%RH):	26(°C)/60 %RH
Mode:	Mode 4		
Ant.Polar.:	Vertical		

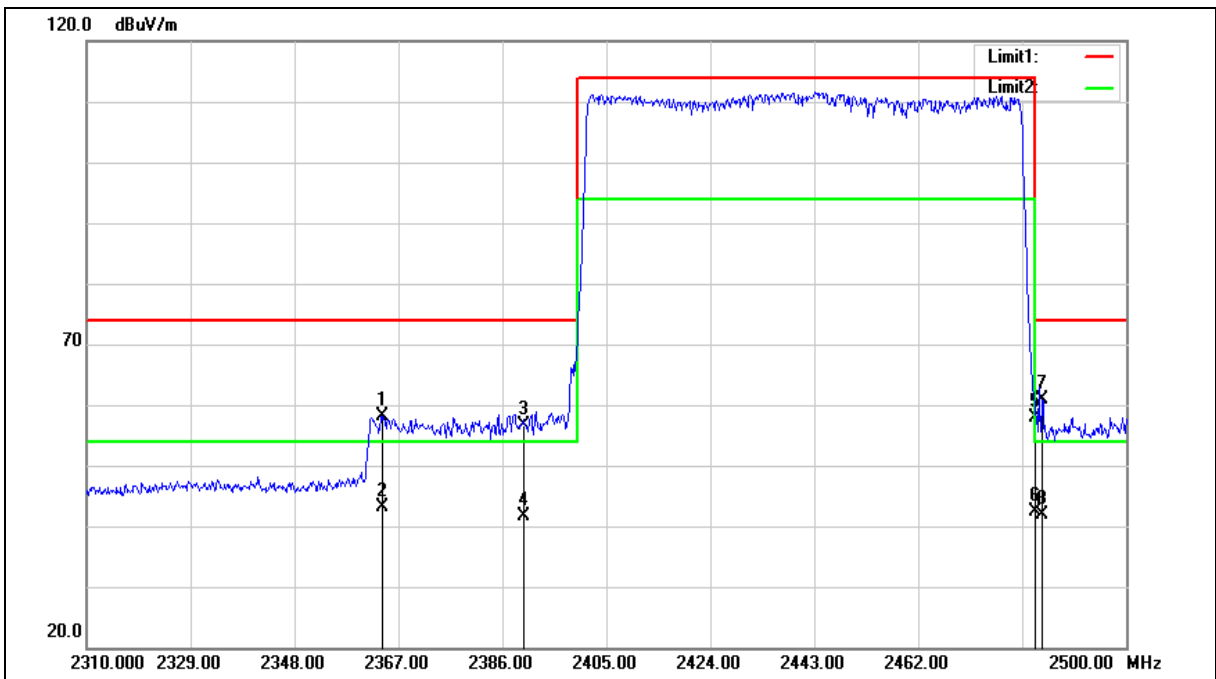



Standard:	FCC Part 15.247	Test Distance:	3 m
Test item:	Band edge	Power:	DC 3.3 V
Frequency:	Hopping	Temp.(°C)/Hum.(%RH):	26(°C)/60 %RH
Mode:	Mode 4		
Ant.Polar.:	Vertical		

No.	Frequency (MHz)	Reading (dBuV)	Correct Factor (dB/m)	Result (dBuV/m)	Limit (dBuV/m)	Margin (dB)	Remark
1	2363.960	67.82	-9.72	58.10	74.00	-15.90	peak
2	2363.960	52.81	-9.72	43.09	54.00	-10.91	AVG
3	2390.000	66.18	-9.62	56.56	74.00	-17.44	peak
4	2390.000	51.36	-9.62	41.74	54.00	-12.26	AVG
5	2483.500	67.22	-9.37	57.85	74.00	-16.15	peak
6	2483.500	51.68	-9.37	42.31	54.00	-11.69	AVG
7	2484.610	70.29	-9.37	60.92	74.00	-13.08	peak
8	2484.610	51.29	-9.37	41.92	54.00	-12.08	AVG

Note:1.Result (dBuV/m) = Correct Factor (dB/m) + Reading(dBuV).

2.Correction factor (dB/m) = Antenna Factor (dB/m) + Cable loss (dB) – Pre-Amplifier gain (dB).

3.When the peak results are less than average limit, so not need to evaluate the average.