FCC Test Report

Report No.: AGC07S110601F2

FCC ID : XELH-680
PRODUCT DESIGNATION : Bluetooth Stereo Headset
BRAND NAME : ORICORE
TEST MODEL : H-680
CLIENT : Shenzhen Hongnanke Communication Equipment CO., Ltd
DATE OF ISSUE : June 18, 2011
STANDARD(S) : FCC Part 15 Rules

Attestation of Global Compliance Co., Ltd.

CAUTION: This report shall not be reproduced except in full without the written permission of the test laboratory and shall not be quoted out of context.

VERIFICATION OF COMPLIANCE

Applicant	Shenzhen Hongnanke Communication Equipment CO., Ltd
	No.16, the Second Industry Park, Xiakeng Tongle, Longgang District, Shenzhen, Guangdong, China.
Manufacturer	Shenzhen Hongnanke Communication Equipment CO., Ltd
	No.16, the Second Industry Park, Xiakeng Tongle, Longgang District, Shenzhen, Guangdong, China.
Product Designation	Bluetooth Stereo Headset
Brand Name	ORICORE
Model Name	H-680
FCC ID	XELH-680
Report Number	AGC07S110601F2
Date of Test	June 14, 2011 to June 17, 2011

WE HEREBY CERTIFY THAT:

The above equipment was tested by Attestation of Global Compliance Co., Ltd. The test data, data evaluation, test procedures, and equipment configurations shown in this report were made in accordance with the procedures given in ANSI C63.4 (2003) and the energy emitted by the sample EUT tested as described in this report is in compliance with radiated emission limits of FCC Rules Part 15.247.

Checked By:

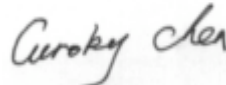

Curoky Chen June 18, 2011

Authorized By

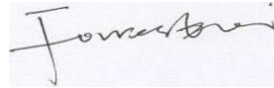

Forrest Lei June 18, 2011

TABLE OF CONTENTS

1 GENERAL INFORMATION	4
1.1PRODUCT DESCRIPTION	4
1.2TABLE OF CARRIER FREQUENCYS	4
1.3RECEIVER INPUT BANDWIDTH	4
1.4EXAMPLE OF A HOPPING SEQUENCY IN DATA MODE	5
1.5EQUALLY AVERAGE USE OF FREQUENCIES AND BEHAVIOUR	5
1.6RELATED SUBMITTAL(S) / GRANT (S)	5
1.7TEST METHODOLOGY	5
1.8TEST FACILITY	6
1.9SPECIAL ACCESSORIES	6
1.10EQUIPMENT MODIFICATIONS	6
2 SYSTEM TEST CONFIGURATION	7
2.1CONFIGURATION OF TESTED SYSTEM	7
2.2EQUIPMENT USED IN TESTED SYSTEM	7
3 SUMMARY OF TEST RESULTS.....	8
4. DESCRIPTION OF TEST MODES.....	8
5 PEAK OUTPUT POWER	9
5.1 MEASUREMENT PROCEDURE	9
5.2 TEST SET-UP (BLOCK DIAGRAM OF CONFIGURATION)	9
5.3 MEASUREMENT EQUIPMENT USED	10
5.4 LIMITS AND MEASUREMENT RESULT	10
6 20 DB BANDWIDTH.....	11
6.1 MEASUREMENT PROCEDURE	11
6.2 TEST SET-UP (BLOCK DIAGRAM OF CONFIGURATION)	11
6.3 MEASUREMENT EQUIPMENT USED	11
6.4 LIMITS AND MEASUREMENT RESULTS	11
7. CONDUCTED SPURIOUS EMISSION.....	13
7.1 MEASUREMENT PROCEDURE	13
7.2 TEST SET-UP (BLOCK DIAGRAM OF CONFIGURATION)	13
7.3 MEASUREMENT EQUIPMENT USED	13
7.4 LIMITS AND MEASUREMENT RESULT	13
8. RADIATED EMISSION.....	15
8.1 MEASUREMENT PROCEDURE	15
8.2 TEST SETUP	16
8.2 TEST EQUIPMENT LIST	17
8.3 TEST RESULT	18
9 BAND EDGES EMISSION.....	24
9.1 MEASUREMENT PROCEDURE	24
9.2 TEST SET-UP	24
9.3 TEST RESULT	24
10. NUMBER OF HOPPING FREQUENCY.....	28
10.1 MEASUREMENT PROCEDURE	28
10.2 TEST SETUP (BLOCK DIAGRAM OF CONFIGURATION)	28
10.3 MEASUREMENT EQUIPMENT USED	28
10.4 LIMITS AND MEASUREMENT RESULT	28

11. TIME OF OCCUPANCY (DWELL TIME)	29
11.1 MEASUREMENT PROCEDURE	29
11.2 TEST SETUP (BLOCK DIAGRAM OF CONFIGURATION)	29
11.3 MEASUREMENT EQUIPMENT USED	29
11.4 LIMITS AND MEASUREMENT RESULT	29
12. FREQUENCY SEPARATION	32
12.1 MEASUREMENT PROCEDURE	32
12.2 TEST SETUP (BLOCK DIAGRAM OF CONFIGURATION)	32
12.3 MEASUREMENT EQUIPMENT USED	32
12.4 LIMITS AND MEASUREMENT RESULT	32
13 FCC LINE CONDUCTED EMISSION TEST	33
13.1 LIMITS OF LINE CONDUCTED EMISSION TEST	33
13.2 BLOCK DIAGRAM OF LINE CONDUCTED EMISSION TEST	33
13.3 PRELIMINARY PROCEDURE OF LINE CONDUCTED EMISSION TEST	34
13.4 FINAL PROCEDURE OF LINE CONDUCTED EMISSION TEST	34
13.5 TEST RESULT OF LINE CONDUCTED EMISSION TEST	35
APPENDIX I	37
PHOTOGRAPHS OF THE EUT	37
APPENDIX II	43
PHOTOGRAPHS OF THE TEST SETUP	43

1 GENERAL INFORMATION

1.1 PRODUCT DESCRIPTION

The EUT is a **Bluetooth Stereo Headset** designed as an "Communication Device". It is designed by way of utilizing the FHSS technology to achieve the system operation.

A major technical description of EUT is described as following

Operation Frequency	2.402 GHz to 2.480GHz
Rated Output Power	2.72dBm(max) for GFSK modulation
Bluetooth Version	V2.1 + EDR
Modulation	GFSK, $\pi/4$ -DQPSK, 8-DPSK
Number of channels	79
Antenna Designation	Integrated Antenna
Antenna Gain	0.82dBi
Power Supply	DC3.7V by Built-in Li-ion Battery(or charged by adapter)

1.2 TABLE OF CARRIER FREQUENCIES

Frequency Band	Channel Number	Frequency
2400~2483.5MHZ	0	2402MHZ
	1	2403MHZ
	:	:
	38	2440 MHZ
	39	2441 MHZ
	40	2442 MHZ
	:	:
	77	2479 MHZ
	78	2480 MHZ

1.3 RECEIVER INPUT BANDWIDTH

The input bandwidth of the receiver is 1MHZ, In every connection one Bluetooth device is the master and the other one is slave. The master determines the hopping sequence. The slave follows this sequence. Both devices shift between RX and TX time slot according to the clock of the master. Additionally the type of connection(e.g. single of multislot packet) is set up at the beginning of the connection. The master adapts its hopping frequency and its TX/RX timing according to the packet type of the connection. Also the slave of the connection will use these settings.

Repeating of a packet has no influence on the hopping sequence. The hopping sequence generated by the master of the connection will be followed in any case. That means, a repeated packet will not be send on the same frequency, it is send on the next frequency of the hopping sequence.

1.4 EXAMPLE OF A HOPPING SEQUENCY IN DATA MODE

Example of a 79 hopping sequence in data mode:
40,21,44,23,42,53,46,55,48,33,52,35,50,65,54,67
56,37,60,39,58,69,62,71,64,25,68,27,66,57,70,59
72,29,76,31,74,61,78,63,01,41,05,43,03,73,07,75
09,45,13,47,11,77,15,00,64,49,66,53,68,02,70,06
01,51,03,55,05,04

1.5 EQUALLY AVERAGE USE OF FREQUENCIES AND BEHAVIOUR

The generation of the hopping sequence in connection mode depends essentially on two input values:

1 LAP/UAP of the master of the connection

2 Internal master clock

The LAP(lower address part) are the 24 LSB's of the 48 BD_ADDRESS. The BD_ADDRESS is an unambiguous number of every Bluetooth unit. The UAP(upper address part) are the 24MSB's of the 48BD_ADDRESS

The internal clock of a Bluetooth unit is derived from a free running clock which is never adjusted and is never turned off. For synchronization with other units only offset are used. It has no relation to the time of the day. Its resolution is at least half the RX/TX slot length of 312.5us. The clock has a cycle of about one day(23h30). In most cases it is implemented as 28 bit counter. For the deriving of the hopping sequence the entire.

LAP(24 bits), 4LSB's(4bits)(Input 1) and the 27MSB's of the clock(Input 2) are used. With this input values different mathematical procedures(permutations, additions, XOR-operations)are performed to generate the

Sequence. This will be done at the beginning of every new transmission.

Regarding short transmissions the Bluetooth system has the following behavior:

The first connection between the two devices is established, a hopping sequence was generated. For transmitting the wanted data the complete hopping sequence was not used. The connection ended.

The second connection will be established. A new hopping sequence is generated. Due to the fact the Bluetooth clock has a different value, because the period between the two transmission is longer(and it cannot be shorter)than the minimum resolution of the clock(312.5us).The hopping sequence will always differ from the first one.

1.6 RELATED SUBMITTAL(S) / GRANT (S)

This submittal(s) (test report) is intended for **FCC ID: XELH-680** filing to comply with Section 15.247 of the FCC Part 15, Subpart C Rules.

1.7 TEST METHODOLOGY

Both conducted and radiated testing were performed according to the procedures in ANSI C63.4 (2003). Radiated testing was performed at an antenna to EUT distance 3 meters.

1.8 TEST FACILITY

All measurement facilities used to collect the measurement data are located at
Attestation of Global Compliance Co., Ltd.

1F., No.2 Building, Huafeng No.1 Technical Industrial Park, Sanwei, Xixiang, Baoan District, Shenzhen

The test site is constructed and calibrated to meet the FCC requirements in documents ANSI C63.4: 2003.

FCC register No.: 259865

1.9 SPECIAL ACCESSORIES

Refer to section 2.2.

1.10 EQUIPMENT MODIFICATIONS

Not available for this EUT intended for grant.

2 SYSTEM TEST CONFIGURATIONS

2.1 CONFIGURATION OF TESTED SYSTEM

Configure 1(Normal Hopping + charging by adapter)

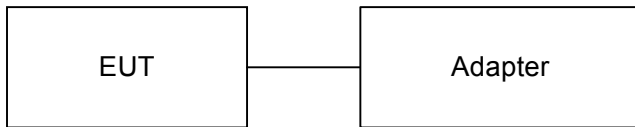

Configure 2(Connect PC and make EUT continuous transmitting)

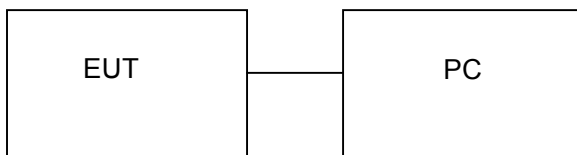

2.2 EQUIPMENT USED IN TESTED SYSTEM

Item	Equipment	Mfr/Brand	Model/Type No.	Remark
1	Bluetooth Stereo Headset	ORICORE	H-680	EUT
2	Adapter	ORICORE	HNK-BC	accessory
3	battery	--	492530	accessory
4	PC	LENOVO	A4600K	A.E.

3 SUMMARY OF TEST RESULTS

FCC RULES	DESCRIPTION OF TEST	RESULT
§15.247	Peak Output Power	Compliant
§15.247	20 dB Bandwidth	Compliant
§15.247	Conducted Spurious Emission	Compliant
§15.209	Radiated Emission	Compliant
§15.247	Band Edges	Compliant
§15.247	Number of Hopping Frequency	Compliant
§15.247	Time of Occupancy	Compliant
§15.247	Frequency Separation	Compliant
§15.207	Line Conduction Emission	Compliant

4. DESCRIPTION OF TEST MODES

The EUT has been operate in three modulations: GFSK, $\pi/4$ -DQPSK, 8-DPSK independently. For each kind of configuration, the following operating modes were applied for the related test items..

No.	TEST MODES
1	Low Channel(TX)
2	Middle Channel(TX)
3	High Channel(TX)
4	Normal Hopping
5	Normal Hopping + Charging by adapter

Note: Only the result of the worst case was recorded in the report.

5 PEAK OUTPUT POWER

5.1 MEASUREMENT PROCEDURE

1. The EUT was placed on a turn table which is 0.8m above ground plane.
2. Connect EUT RF output port to the Spectrum Analyzer through an RF attenuator
3. Set the EUT Work on the top, the middle and the bottom operation frequency individually.
4. Set Span = approximately 5 times the 20 dB bandwidth, centered on a hopping channel
RBW > the 20 dB bandwidth of the emission being measured
VBW \geq RBW; Sweep = auto; Detector function = peak
5. Set SPA Trace 1 Max hold, then View.

5.2 TEST SET-UP (BLOCK DIAGRAM OF CONFIGURATION)

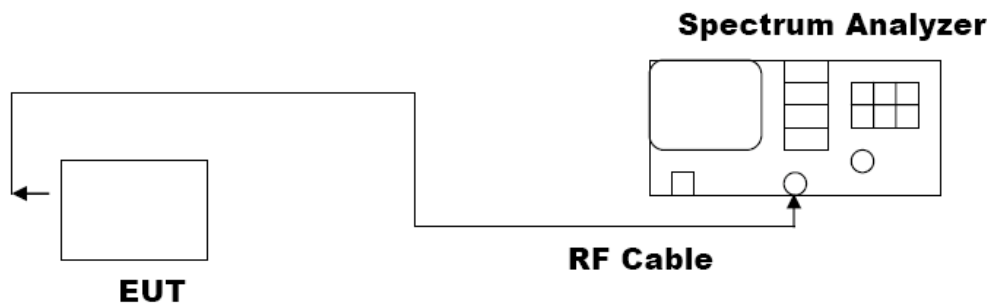

5.3 MEASUREMENT EQUIPMENT USED

Description	Manufacturer	Model	SERIAL NUMBER	Cal. Date	Cal. Due
Spectrum Analyzer	Agilent	E4440A	N/A	06/29/2010	06/28/2011

5.4 LIMITS AND MEASUREMENT RESULT

BLUETOOTH 1MBPS FOR GFSK MODULATION LIMITS AND MEASUREMENT RESULT			
Frequency (GHz)	Result (dBm)	Applicable Limits (dBm)	Pass or Fail
2.402	2.64	30	Pass
2.441	2.72	30	Pass
2.480	2.67	30	Pass

6 20 DB BANDWIDTH

6.1 MEASUREMENT PROCEDURE

1. The EUT was placed on a turn table which is 0.8m above ground plane.
2. Connect EUT RF output port to the Spectrum Analyzer through an RF attenuator
3. Set the EUT Work on the top, the middle and the bottom operation frequency individually.
4. Set Span = approximately 2 to 3 times the 20 dB bandwidth, centered on a hopping channel
RBW \geq 1% of the 20 dB bandwidth, VBW \geq RBW; Sweep = auto; Detector function = peak
5. Set SPA Trace 1 Max hold, then View.

6.2 TEST SET-UP (BLOCK DIAGRAM OF CONFIGURATION)

The same as described in Section 5.2

6.3 MEASUREMENT EQUIPMENT USED

The same as described in Section 5.3

6.4 LIMITS AND MEASUREMENT RESULTS

THE MEASUREMENT RESULT WITH THE WORST CASE OF 3MBPS FOR 8-DPSK MODULATION			
Applicable Limits	Measurement Result		
	Test Data (MHz)		Criteria
--	Low Channel	1.300	PASS
	Middle Channel	1.299	PASS
	High Channel	1.298	PASS

TEST PLOT OF BANDWIDTH FOR LOW CHANNEL

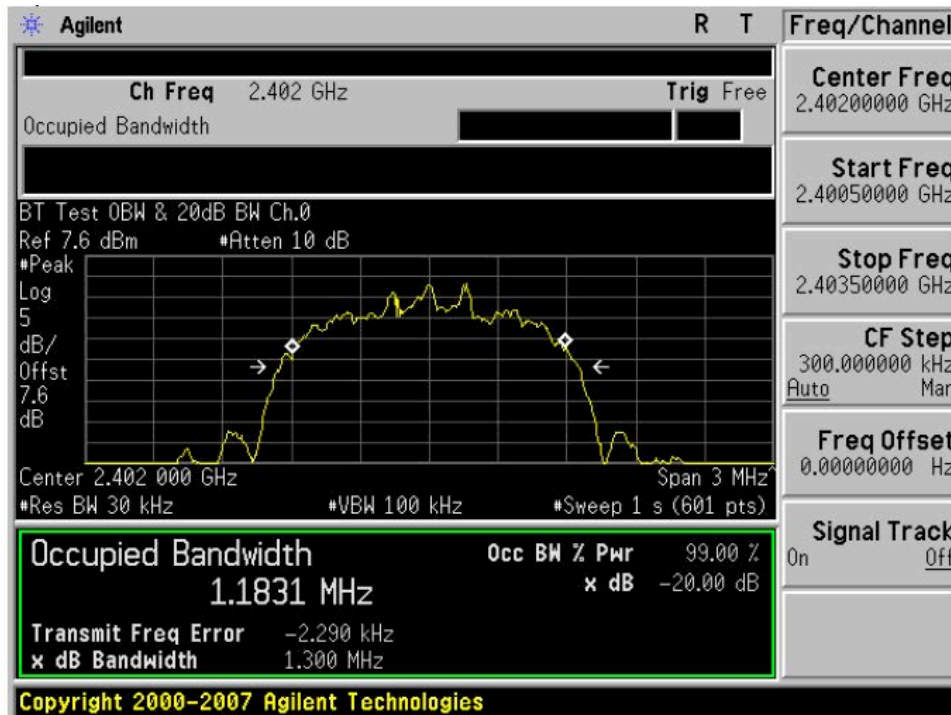

TEST PLOT OF BANDWIDTH FOR MIDDLE CHANNEL

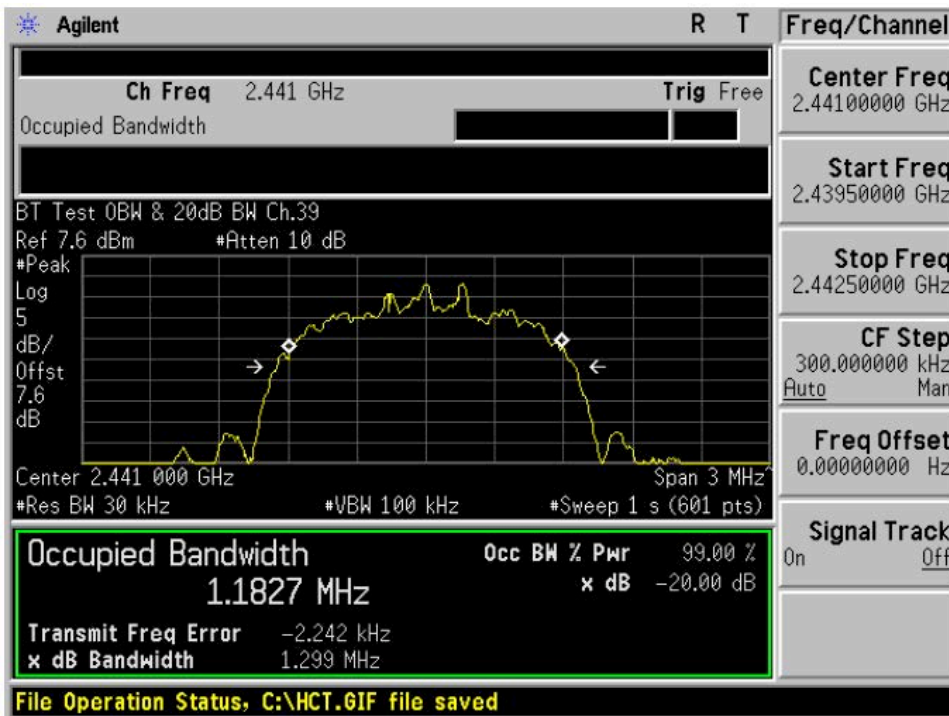

TEST PLOT OF BANDWIDTH FOR HIGH CHANNEL

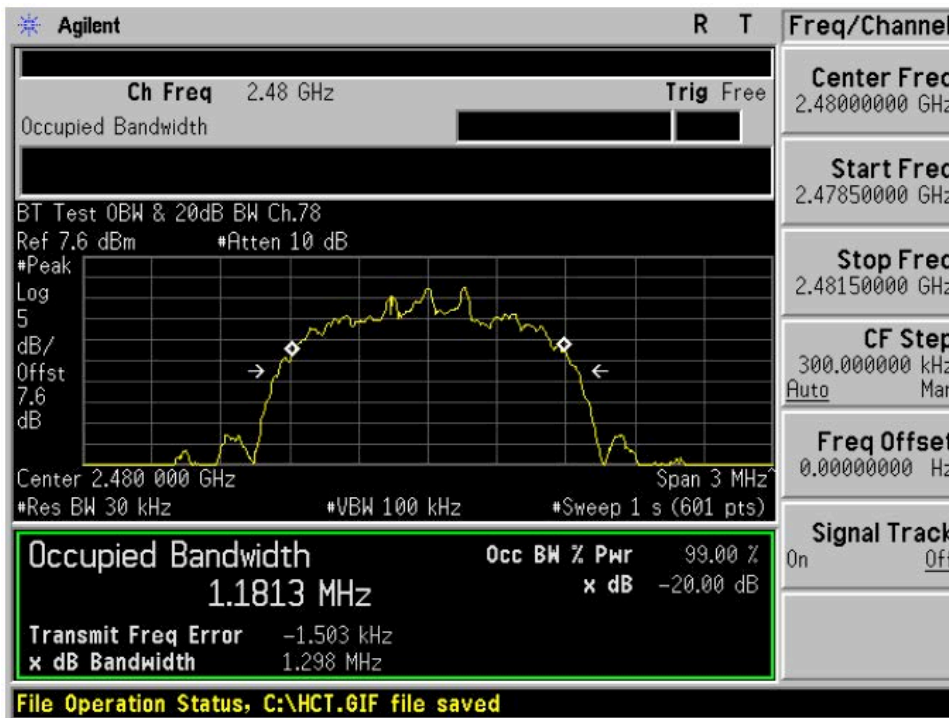

7. CONDUCTED SPURIOUS EMISSION

7.1 MEASUREMENT PROCEDURE

1. The EUT was placed on a turn table which is 0.8m above ground plane.
2. Connect EUT RF output port to the Spectrum Analyzer through an RF attenuator
3. Set the EUT Work on the top, the middle and the bottom operation frequency individually.
4. Set the Span = wide enough to capture the peak level of the in-band emission and all spurious emissions from the lowest frequency generated in the EUT up through the 10th harmonic.
RBW = 100 kHz; VBW ≥ RBW; Sweep = auto; Detector function = peak
5. Set SPA Trace 1 Max hold, then View.

7.2 TEST SET-UP (BLOCK DIAGRAM OF CONFIGURATION)

The Same as described in section 5.2

7.3 MEASUREMENT EQUIPMENT USED

The Same as described in section 5.3

7.4 LIMITS AND MEASUREMENT RESULT

LIMITS AND MEASUREMENT RESULT		
Applicable Limits	Measurement Result	
	Test Data	Criteria
<p>In any 100 KHz Bandwidth Outside the frequency band in which the spread spectrum intentional radiator is operating, the radio frequency power that is produce by the intentional radiator shall be at least 20 dB below that in 100KHz bandwidth within the band that contains the highest level of the desired power.</p>	<p>At least -20dBc than the limit Specified on the BOTTOM Channel</p>	<p>PASS</p>
<p>In addition, radiation emissions which fall in the restricted bands, as defined in §15.205(a), must also comply with the radiated emission limits specified in§15.209(a))</p>	<p>At least -20dBc than the limit Specified on the TOP Channel</p>	<p>PASS</p>

CONDUCTED SPURIOUS EMISSIONS WITH THE WORST CASE
 FOR 8-DPSK MODULATION

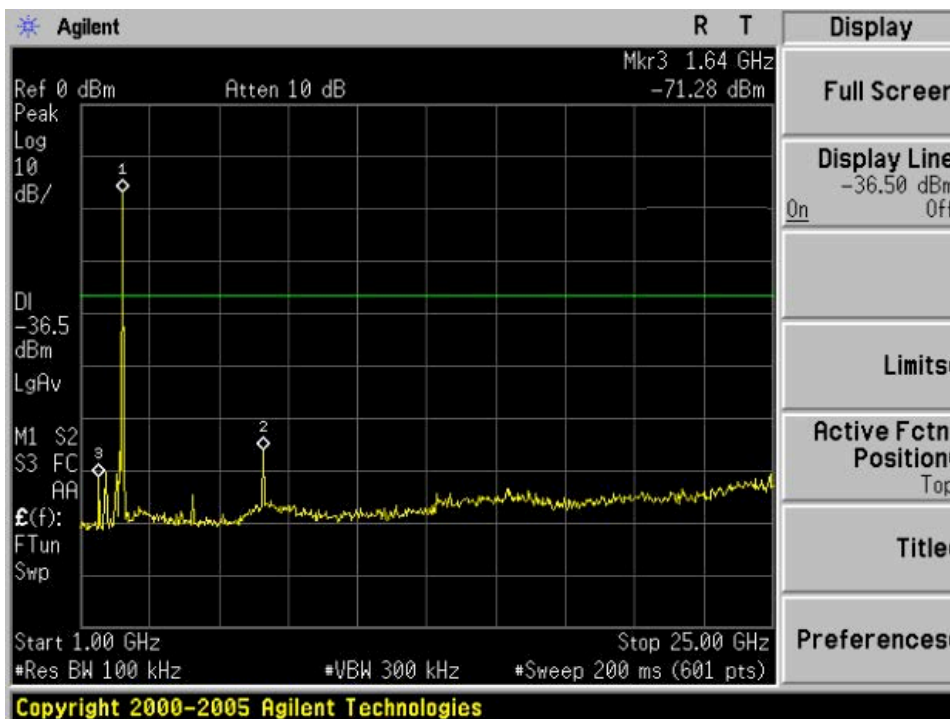
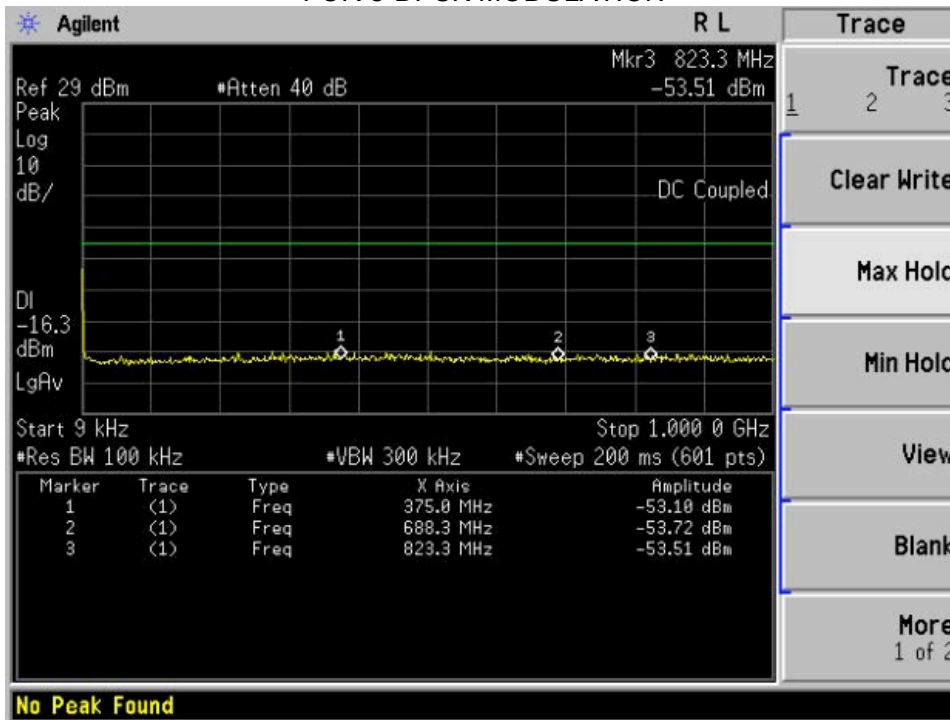

8. RADIATED EMISSION

8.1 MEASUREMENT PROCEDURE

1. Configure the EUT according to ANSI C63.4. The EUT was placed on the top of the turntable 0.8 meter above ground. The phase center of the receiving antenna mounted on the top of a height-variable antenna tower was placed 3 meters far away from the turntable.
2. Power on the EUT and all the supporting units. The turntable was rotated by 360 degrees to determine the position of the highest radiation.
3. The height of the broadband receiving antenna was varied between one meter and four meters above ground to find the maximum emissions field strength of both horizontal and vertical polarization.
4. For each suspected emissions, the antenna tower was scan (from 1 M to 4 M) and then the turntable was rotated (from 0 degree to 360 degrees) to find the maximum reading.
5. Set the test-receiver system to Peak or CISPR quasi-peak Detect Function with specified bandwidth under Maximum Hold Mode.
6. For emissions above 1GHz, use 1MHz VBW and RBW for peak reading. Then 1MHz RBW and 10Hz VBW for average reading in spectrum analyzer.
7. When the radiated emissions limits are expressed in terms of the average value of the emissions, and pulsed operation is employed, the measurement field strength shall be determined by averaging over one complete pulse train, including blanking intervals, as long as the pulse train does not exceed 0.1 seconds. As an alternative (provided the transmitter operates for longer than 0.1 seconds) or in cases where the pulse train exceeds 0.1 seconds, the measured field strength shall be determined from the average absolute voltage during a 0.1 second interval during which the field strength is at its maximum value.
8. If the emissions level of the EUT in peak mode was 3 dB lower than the average limit specified, then testing will be stopped and peak values of EUT will be reported, otherwise, the emissions which do not have 3 dB margin will be repeated one by one using the quasi-peak method for below 1GHz.
9. For testing above 1GHz, the emissions level of the EUT in peak mode was lower than average limit (that means the emissions level in peak mode also complies with the limit in average mode), then testing will be stopped and peak values of EUT will be reported, otherwise, the emissions will be measured in average mode again and reported.
10. In case the emission is lower than 30MHz, loop antenna has to be used for measurement and the recorded data should be QP measured by receiver. High – Low scan is not required in this case.

The following table is the setting of spectrum analyzer and receiver.'

Spectrum Parameter	Setting
Start Frequency	1GHz
Stop Frequency	26.5GHz
RB/VB(Emission in restricted band)	1MHz/1MHz for Peak, 1MHz/10Hz for Average
RB/VB(Emission in non-restricted band)	1MHz/1MHz for Peak

Receiver Parameter	Setting
Start ~Stop Frequency	9KHz~150KHz/RB 200Hz for QP
Start ~Stop Frequency	150KHz~30MHz/RB 9KHz for QP
Start ~Stop Frequency	30MHz~1000MHz/RB 120KHz for QP

8.2 TEST SETUP

RADIATED EMISSION TEST SETUP BELOW 30MHz

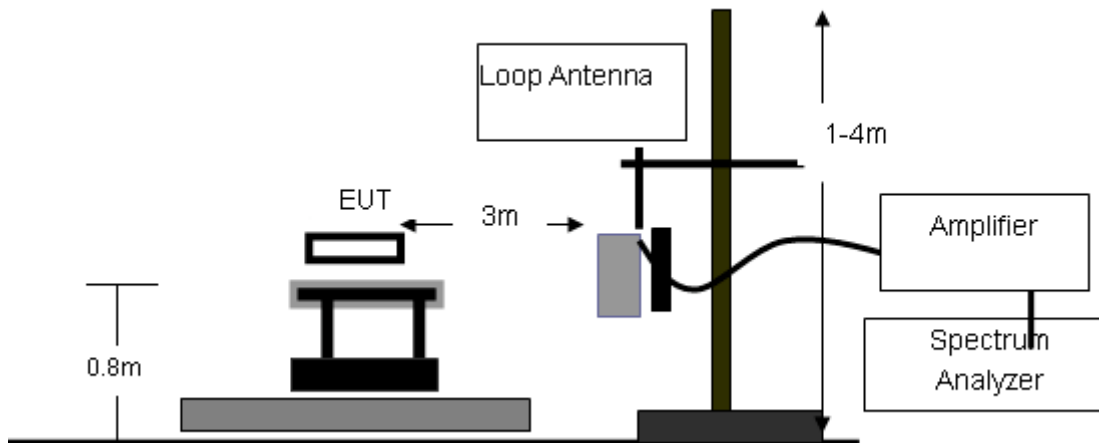

RADIATED EMISSION TEST SETUP 30MHz-1000MHz

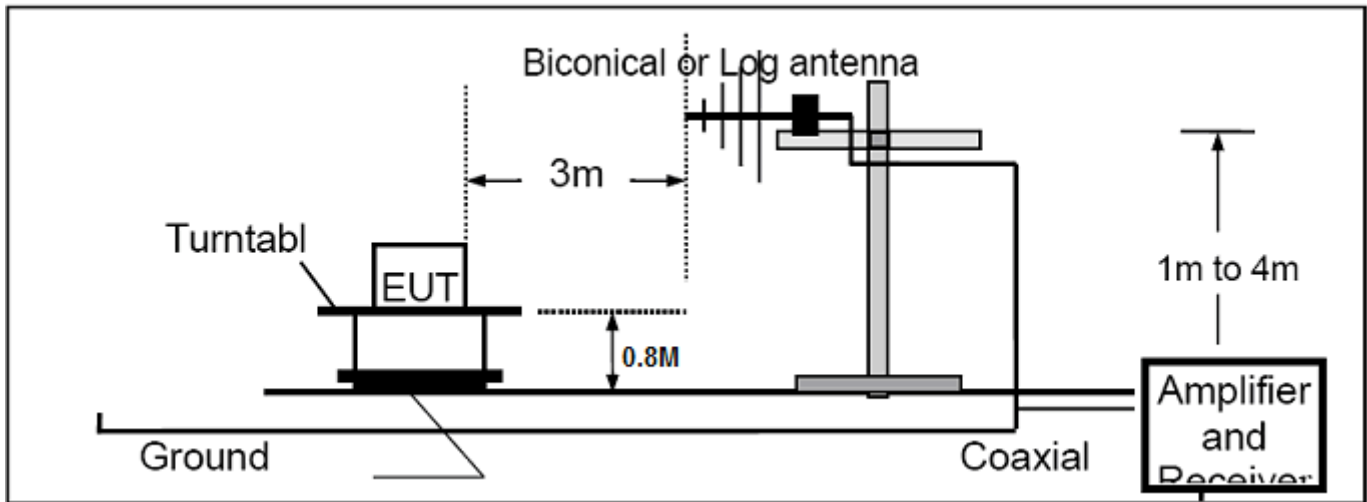

RADIATED EMISSION TEST SETUP ABOVE 1000MHz

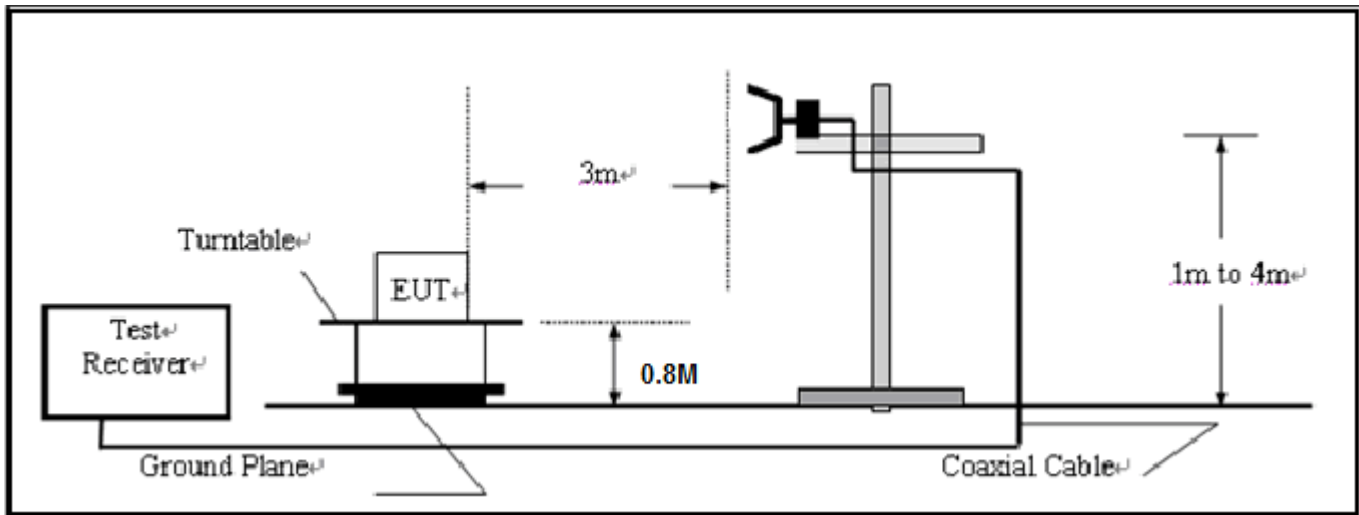

8.3 TEST EQUIPMENT LIST

Description	Manufacturer	Model	SERIAL NUMBER	Cal. Date	Cal. Due
Spectrum Analyzer	Agilent	E4440A	N/A	06/29/2010	06/28/2011
Amplifier	EM	EM30180	0607030	06/29/2010	06/28/2011
Horn Antenna	EM	EM-AH-10180	N/A	06/29/2010	06/28/2011
Horn Antenna	A.H. Systems Inc.	SAS-574	--	06/29/2010	06/28/2011
EMI Test Receiver	Rohde & Schwarz	ESCI	N/A	06/29/2010	06/28/2011
Amplifier	EM	EM30180	N/A	06/29/2010	06/28/2011
Biological Antenna	A.H. Systems Inc.	SAS-521-4	N/A	06/29/2010	06/28/2011
Loop Antenna	Daze	ZN30900N	SEL0097	06/29/2010	06/28/2011
Isolation Transformer	LETEAC	LTBK	--	06/29/2010	06/28/2011

8.4 TEST RESULT

RADIATED EMISSION BELOW 30MHZ

No emission found between lowest internal used/generated frequency to 30MHz.

RADIATED EMISSION BELOW 1GHZ

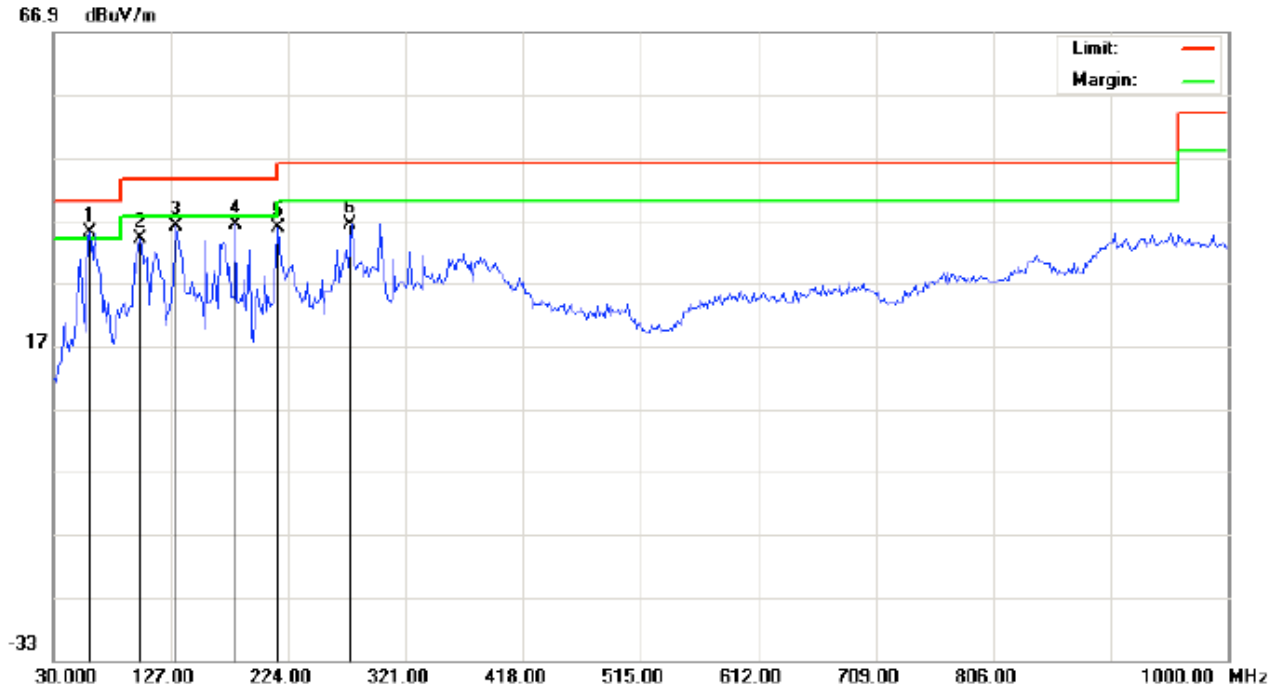

Site: site #1	Polarization: <i>Horizontal</i>	Temperature: 26
Limit: FCC Class B 3M Radiation	Power:	Humidity: 60 %
EUT: Bluetooth Stereo Headset	Distance: 3m	
M/N: H-680		
Mode: 2402TX		
Note:		

No.	Mk	Freq.	Reading	Factor	Measurement	Limit	Over	Detector	Antenna Height	Table Degree	Comment
		MHz	dBuV	dB/m	dBuV/m	dBuV/m	dB		cm	degree	
1	*	60.7167	16.12	18.95	35.07	40.00	-4.93	peak			
2		101.1333	18.15	15.77	33.92	43.50	-9.58	peak			
3		131.8497	21.91	14.04	35.95	43.50	-7.55	peak			
4		180.3497	18.14	18.05	36.19	43.50	-7.31	peak			
5		215.9165	22.93	12.93	35.86	43.50	-7.64	peak			
6		275.7332	19.03	17.20	36.23	46.00	-9.77	peak			

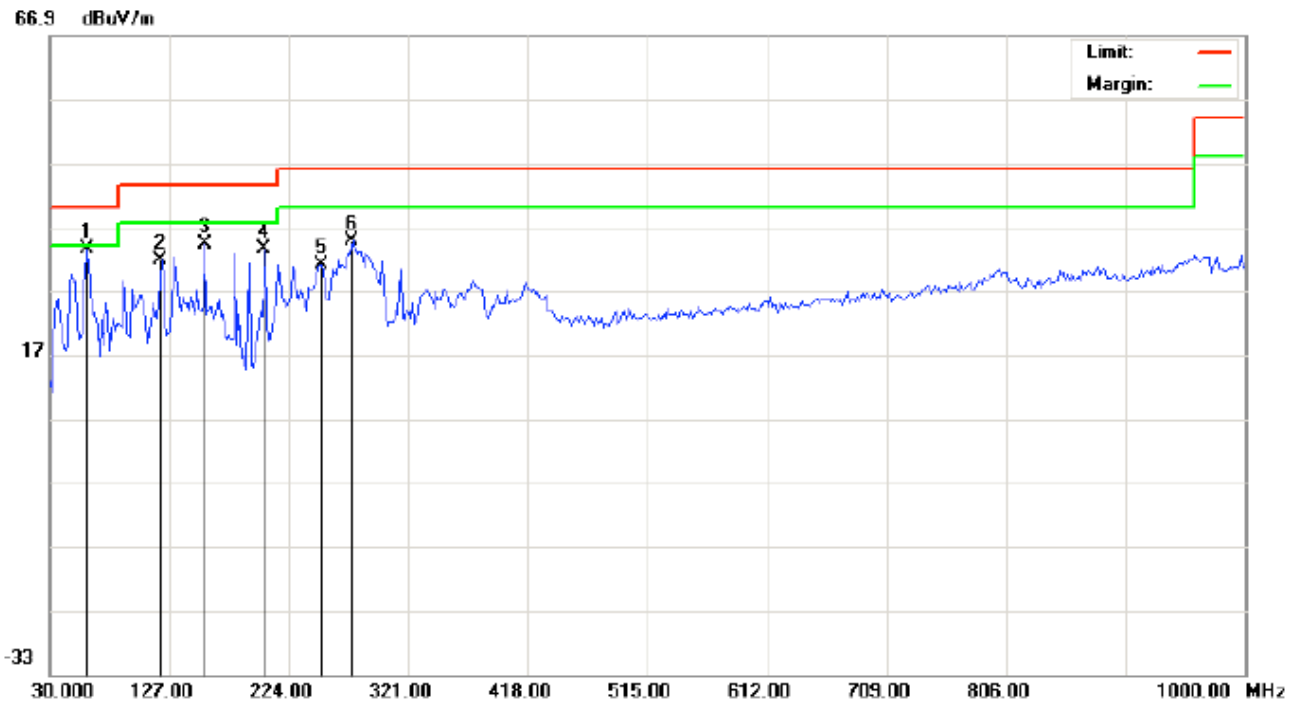

Site: site #1
Limit: FCC Class B 3M Radiation
EUT: Bluetooth Stereo Headset
M/N: H-680
Mode: 2402TX
Note:

Polarization: *Vertical*
Power:
Distance: 3m

Temperature: 26
Humidity: 60 %

No.	Mk	Freq.	Reading	Factor	Measurement	Limit	Over	Detector	Antenna Height	Table Degree	Comment
		MHz	dBuV	dB/m	dBuV/m	dBuV/m	dB		cm	degree	
1	*	60.7167	15.74	17.71	33.45	40.00	-6.55	peak			
2		120.5331	17.44	14.22	31.66	43.50	-11.84	peak			
3		156.0997	20.83	13.49	34.32	43.50	-9.18	peak			
4		204.5997	18.50	14.96	33.46	43.50	-10.04	peak			
5		249.8667	13.92	17.23	31.15	46.00	-14.85	peak			
6		275.7332	17.48	17.20	34.68	46.00	-11.32	peak			

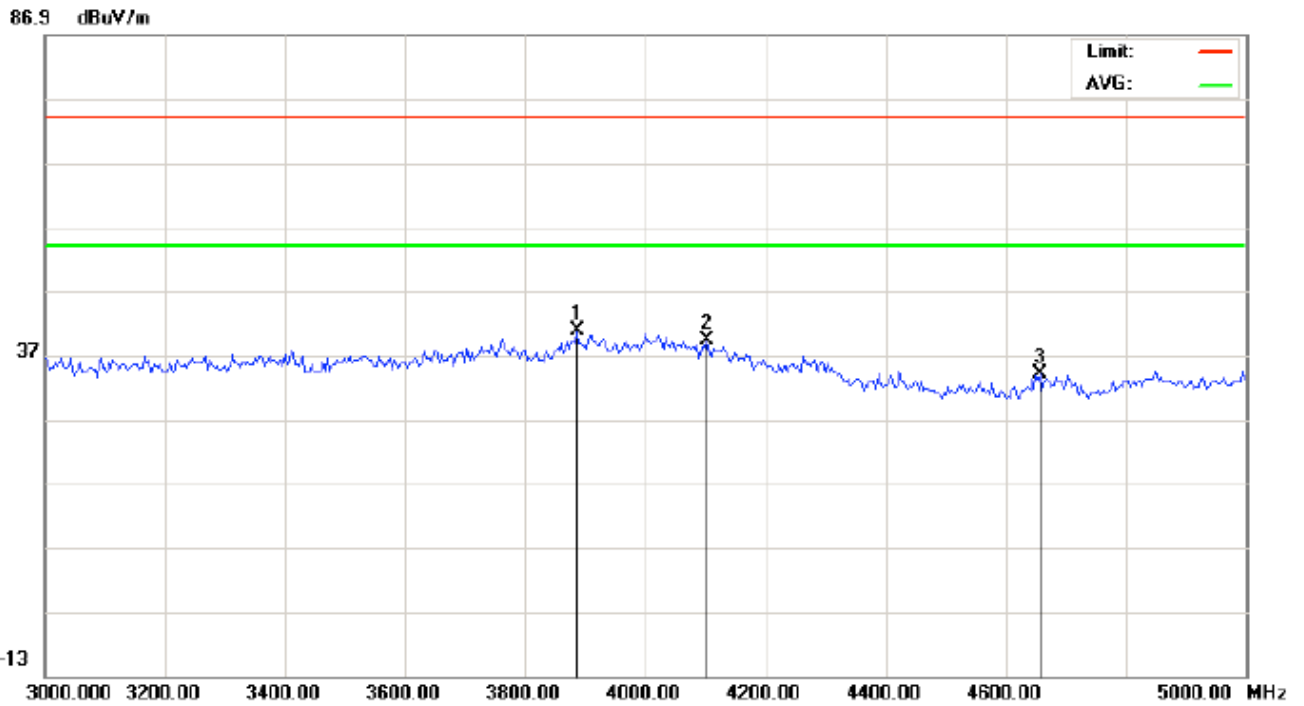

Site: site #1 Polarization: *Horizontal* Temperature: 26
Limit: FCC Class B 3M Radiation above 1GHZ(PK) Power: Humidity: 60 %
EUT: Bluetooth Stereo Headset Distance: 3m
M/N: H-680
Mode: 2402TX
Note:

No.	Mk	Freq.	Reading	Factor	Measurement	Limit	Over	Detector	Antenna Height	Table Degree	Comment
		MHz	dBuV	dB/m	dBuV/m	dBuV/m	dB		cm	degree	
1	*	3886.667	36.23	4.49	40.72	74.00	-33.28	peak			
2		4103.333	35.83	3.47	39.30	74.00	-34.70	peak			
3		4656.667	36.69	-2.70	33.99	74.00	-40.01	peak			

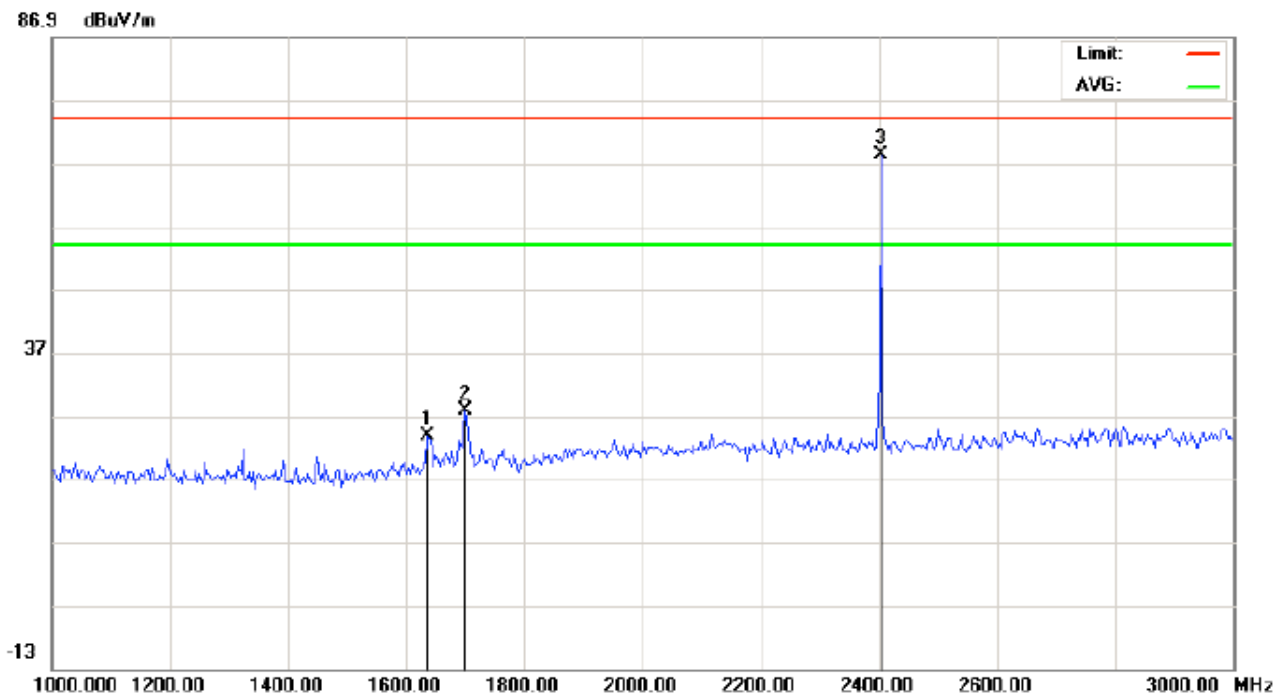

Site: site #1 Polarization: *Vertical* Temperature: 26
Limit: FCC Class B 3M Radiation above 1GHZ(PK) Power: Humidity: 60 %
EUT: Bluetooth Stereo Headset Distance: 3m
M/N: H-680
Mode: 2402TX
Note:

No.	Mk	Freq.	Reading	Factor	Measurement	Limit	Over	Detector	Antenna Height	Table Degree	Comment
		MHz	dBuV	dB/m	dBuV/m	dBuV/m	dB		cm	degree	
1		1636.667	27.72	-3.94	23.78	74.00	-50.22	peak			
2		1700.000	30.94	-3.28	27.66	74.00	-46.34	peak			
3	*	2402.000	67.95	0.32	68.27	74.00	-5.73	peak			

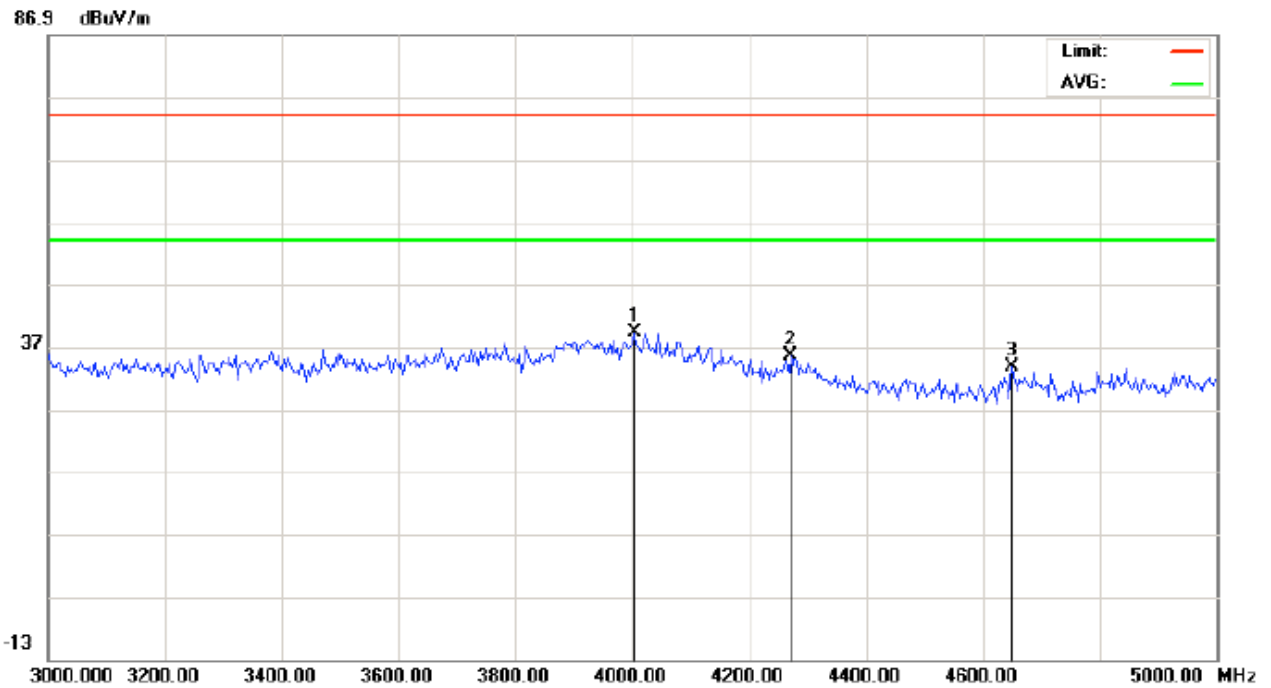

Site: site #1 Polarization: **Vertical** Temperature: 26
 Limit: FCC Class B 3M Radiation above 1GHZ(PK) Power: Humidity: 60 %
 EUT: Bluetooth Stereo Headset Distance: 3m
 M/N: H-680
 Mode: 2402TX
 Note:

No.	Mk	Freq.	Reading	Factor	Measurement	Limit	Over	Detector	Antenna Height	Table Degree	Comment
		MHz	dBuV	dB/m	dBuV/m	dBuV/m	dB		cm	degree	
1	*	4003.333	34.06	5.13	39.19	74.00	-34.81	peak			
2		4270.000	34.77	0.71	35.48	74.00	-38.52	peak			
3		4650.000	36.56	-2.72	33.84	74.00	-40.16	peak			

Note: 5~25GHz at least have 20dB margin. no recording in the test report.
 Factor=Antenna Factor+ Cable loss-Amplifier gain, Margin=Measurement-Limit.

9 BAND EDGES EMISSION

9.1 MEASUREMENT PROCEDURE

1. Set the EUT Work on the top, the bottom operation frequency individually.
2. Set SPA Start or Stop Frequency = Operation Frequency, RBW>=1%span, VBW>=RBW
3. The band edges was measured and recorded.

9.2 TEST SET-UP

The Same as described in section 8.2

9.3 TEST RESULT

TEST PLOT OF BAND EDGE FOR LOW CHANNEL (3Mbps)

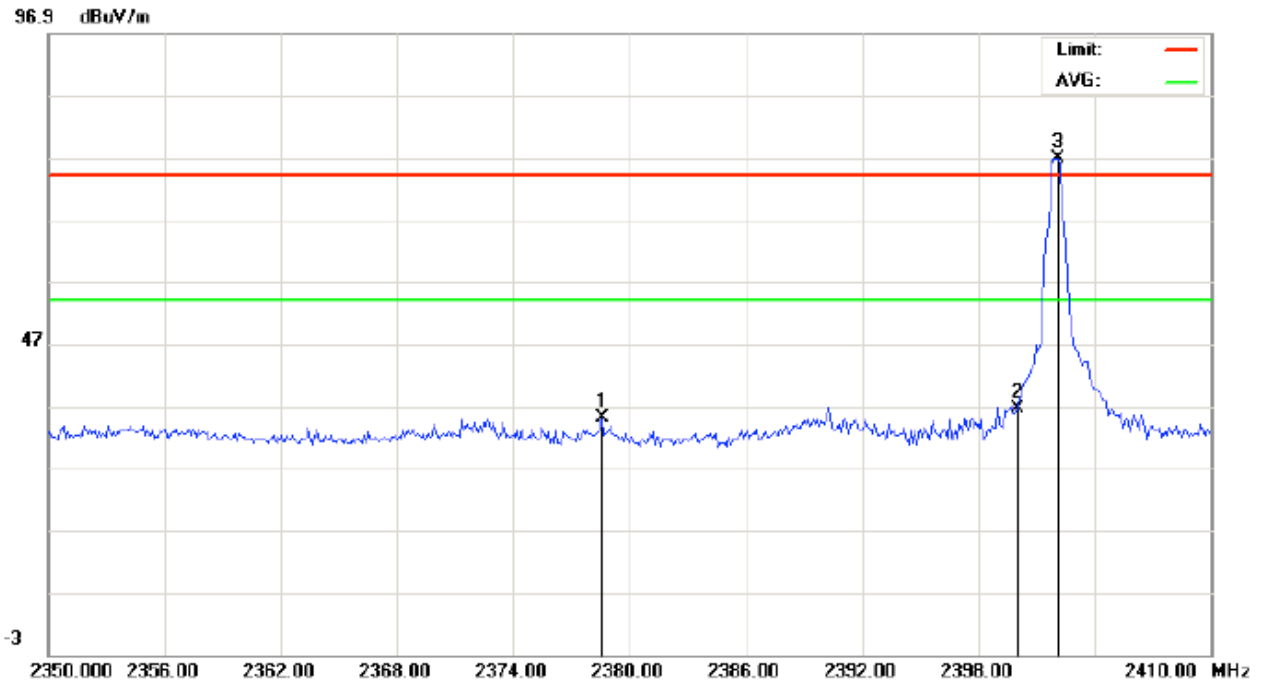

Site: site #1	Polarization: <i>Horizontal</i>	Temperature: 26
Limit: FCC Class B 3M Radiation above 1GHZ(PK)	Power:	Humidity: 60 %
EUT: Bluetooth Stereo Headset	Distance: 3m	
M/N: H-680		
Mode: 2402TX		
Note:		

No.	Mk	Freq.	Reading	Factor	Measurement	Limit	Over	Detector	Antenna	Table	Comment
		MHz	dBuV	dB/m	dBuV/m	dBuV/m	dB		Height	Degree	
1		2378.600	44.64	-9.70	34.94	74.00	-39.06	peak			
2		2400.000	46.11	-9.68	36.43	74.00	-37.57	peak			
3	*	2402.100	86.57	-9.68	76.89	74.00	2.89	peak			

TEST PLOT OF BAND EDGE FOR HIGH CHANNEL (3Mbps)

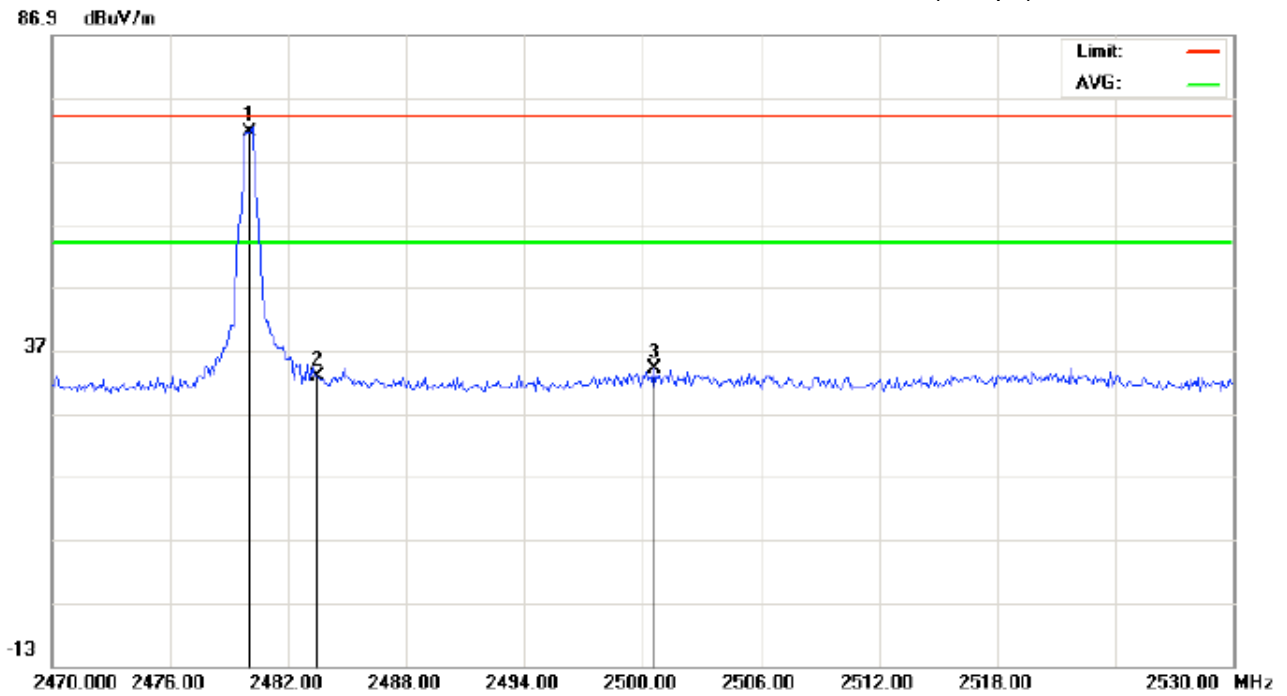

Site: site #1 Polarization: *Horizontal* Temperature: 26
Limit: FCC Class B 3M Radiation above 1GHZ(PK) Power: Humidity: 60 %
EUT: Bluetooth Stereo Headset Distance: 3m
M/N: H-680
Mode: 2480TX
Note:

No.	Mk	Freq.	Reading	Factor	Measurement	Limit	Over	Detector	Antenna Height	Table Degree	Comment
		MHz	dBuV	dB/m	dBuV/m	dBuV/m	dB		cm	degree	
1	*	2480.000	81.23	-9.59	71.64	74.00	-2.36	peak			
2		2483.500	42.43	-9.59	32.84	74.00	-41.16	peak			
3		2500.600	43.68	-9.57	34.11	74.00	-39.89	peak			

10. NUMBER OF HOPPING FREQUENCY

10.1 MEASUREMENT PROCEDURE

1. Place the EUT on the table and set it in transmitting mode.
2. Remove the antenna from the EUT and then connect a low RF cable from the antenna port to the spectrum analyzer.
3. Set the spectrum analyzer Start = 2.4GHz Stop = 2.4835GHz
4. Set the Spectrum Analyzer as RBW>=1%span, VBW>=RBW.

10.2 TEST SETUP (BLOCK DIAGRAM OF CONFIGURATION)

Same as described in section 5.2
Conducted Method.

10.3 MEASUREMENT EQUIPMENT USED

The Same as described in section 5.3

10.4 LIMITS AND MEASUREMENT RESULT

TOTAL NO. OF HOPPING CHANNEL	LIMIT (NO. OF CH)	MEASUREMENT (NO. OF CH)	RESULT
	>=15	79	PASS

TEST PLOT FOR NO. OF TOTAL CHANNELS

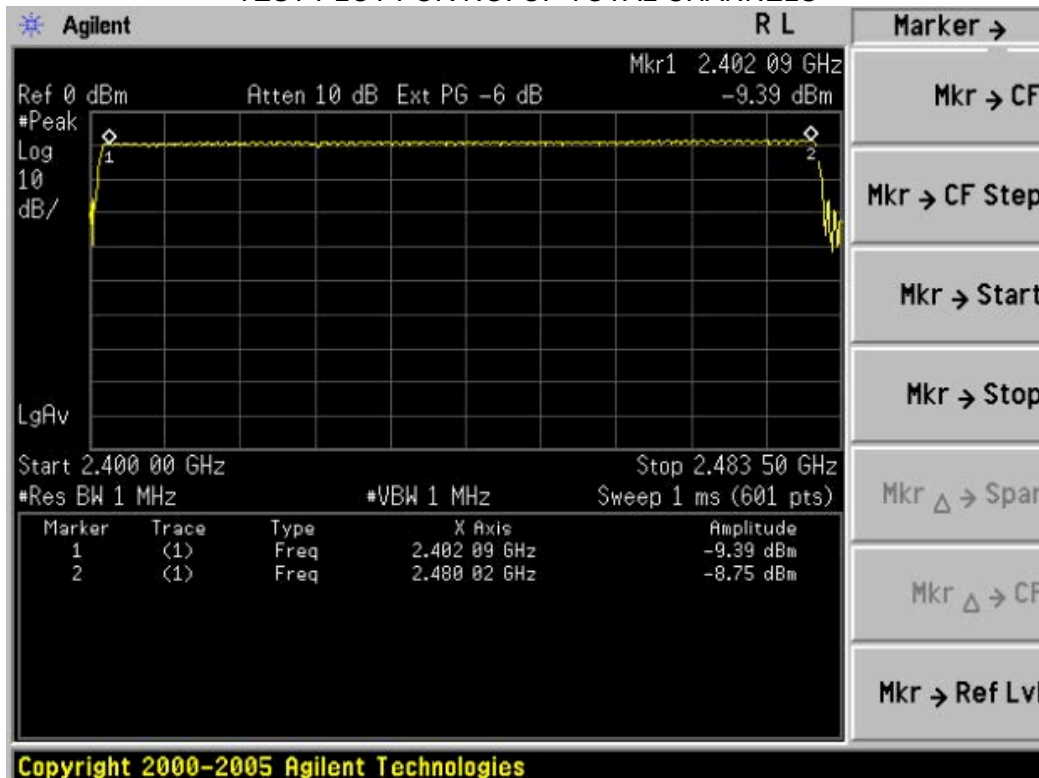

11. TIME OF OCCUPANCY (DWELL TIME)

11.1 MEASUREMENT PROCEDURE

1. Place the EUT on the table and set it in transmitting mode
2. Remove the antenna from the EUT and then connect a low RF cable from the antenna port to the spectrum analyzer
3. Set center frequency of spectrum analyzer = Operating frequency
4. Set the spectrum analyzer as RBW=1MHz, VBW>=RBW, Span = 0 Hz,.

11.2 TEST SETUP (BLOCK DIAGRAM OF CONFIGURATION)

Same as described in section 5.2
Conducted Method

11.3 MEASUREMENT EQUIPMENT USED

The same as described in section 5.3

11.4 LIMITS AND MEASUREMENT RESULT

Bluetooth 3Mbps with DH5 Test Result

Channel	Time of Pulse for DH5 (ms)	Period Time (s)	Sweep Time (ms)	Limit (ms)
Low	2.915	31.6	310.93	400
Middle	2.908	31.6	309.87	400
High	2.920	31.6	311.15	400

Low Channel Time

$$2.915 \times (1600/6) / 79 \times 31.6 = 309.87 \text{ms}$$

Middle Channel Time

$$2.908 \times (1600/6) / 79 \times 31.6 = 309.87 \text{ms}$$

High Channel Time

$$2.920 \times (1600/6) / 79 \times 31.6 = 311.15 \text{ms}$$

TEST PLOT OF LOW CHANNEL

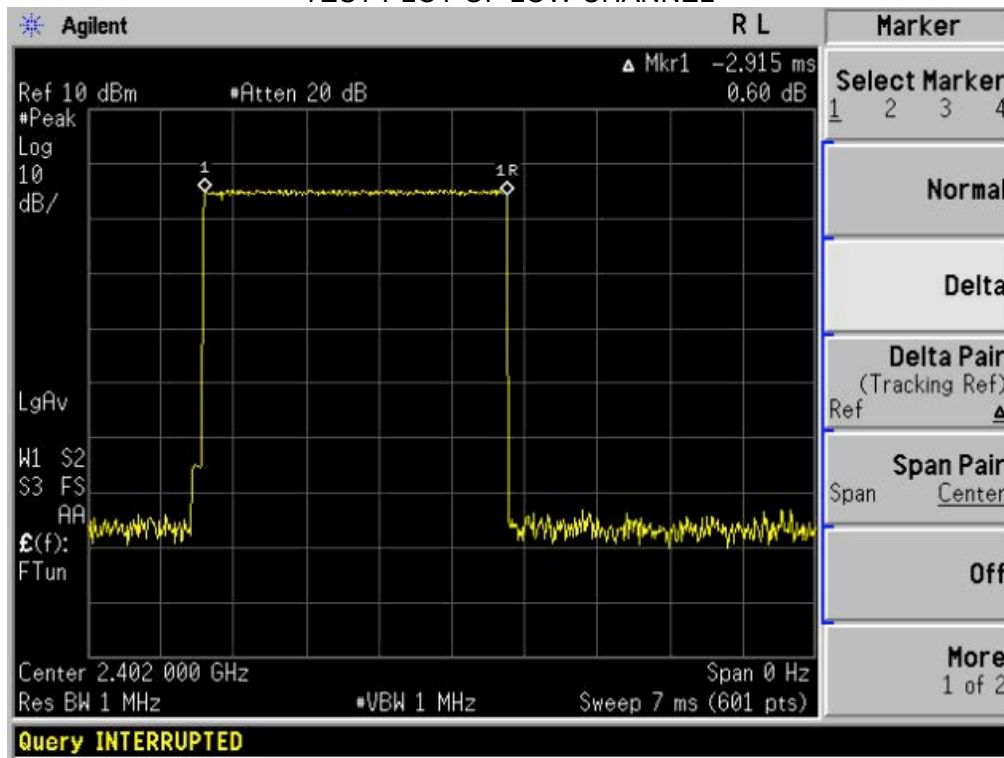

TEST PLOT OF MIDDLE CHANNEL

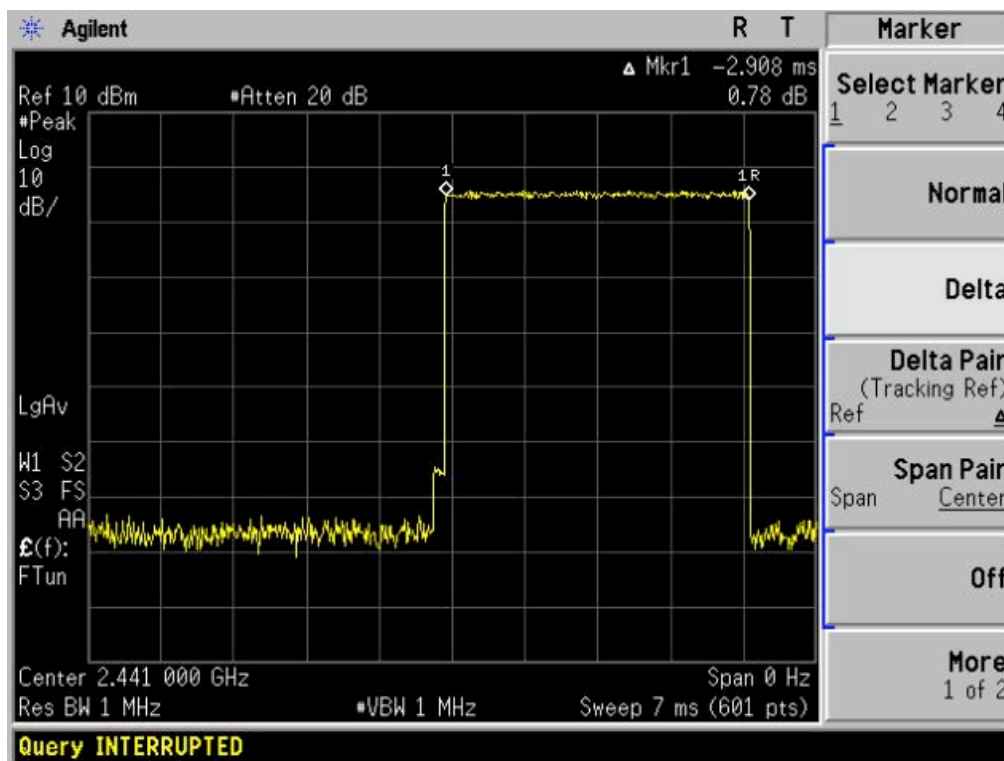

TEST PLOT OF HIGH CHANNEL

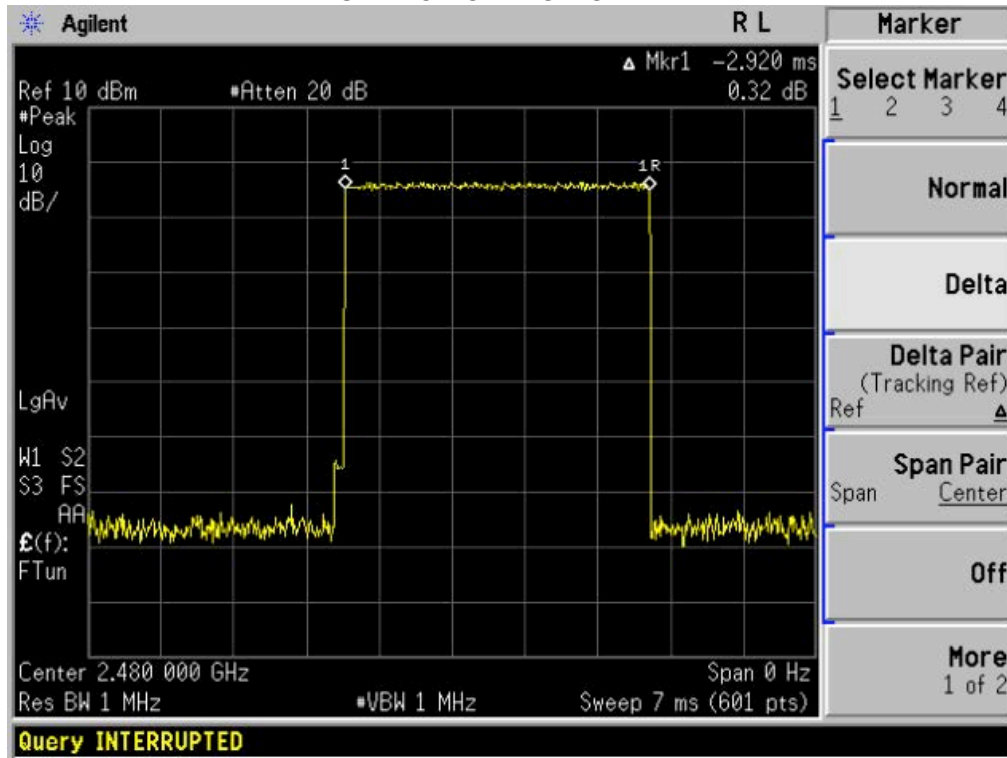

12. FREQUENCY SEPARATION

12.1 MEASUREMENT PROCEDURE

1. Place the EUT on the table and set it in transmitting mode
2. Remove the antenna from the EUT and then connect a low RF cable from the antenna port to the spectrum analyzer
3. Set Span = wide enough to capture the peaks of two adjacent channels Resolution (or IF) Bandwidth (RBW) \geq 1% of the span Video (or Average) Bandwidth (VBW) \geq RBW; Sweep = auto; Detector function = peak; Trace = max hold

12.2 TEST SETUP (BLOCK DIAGRAM OF CONFIGURATION)

Same as described in section 5.2

12.3 MEASUREMENT EQUIPMENT USED

The same as described in section 5.3

12.4 LIMITS AND MEASUREMENT RESULT

BLUETOOTH 3MBPS TEST RESULT

CHANNEL	CHANNEL SEPARATION	LIMIT	RESULT
	KHz	KHz	
CH00-CH01	1000	\geq 25 KHz or 2/3 20 dB BW	Pass

TEST PLOT FOR FREQUENCY SEPARATION

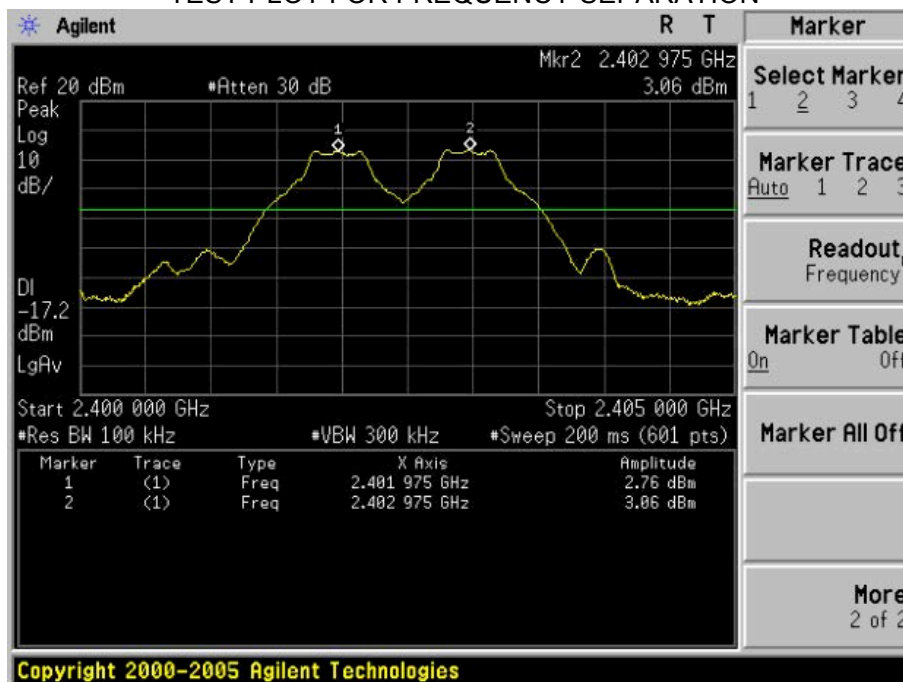

13 FCC LINE CONDUCTED EMISSION TEST

13.1 LIMITS OF LINE CONDUCTED EMISSION TEST

Frequency	Maximum RF Line Voltage	
	Q.P.(dBuV)	Average(dBuV)
150kHz~500kHz	66-56	56-46
500kHz~5MHz	56	46
5MHz~30MHz	60	50

**Note: 1. The lower limit shall apply at the transition frequency.
2. The limit decreases linearly with the logarithm of the frequency in the range 0.15 MHz to 0.50 MHz

13.2 BLOCK DIAGRAM OF LINE CONDUCTED EMISSION TEST

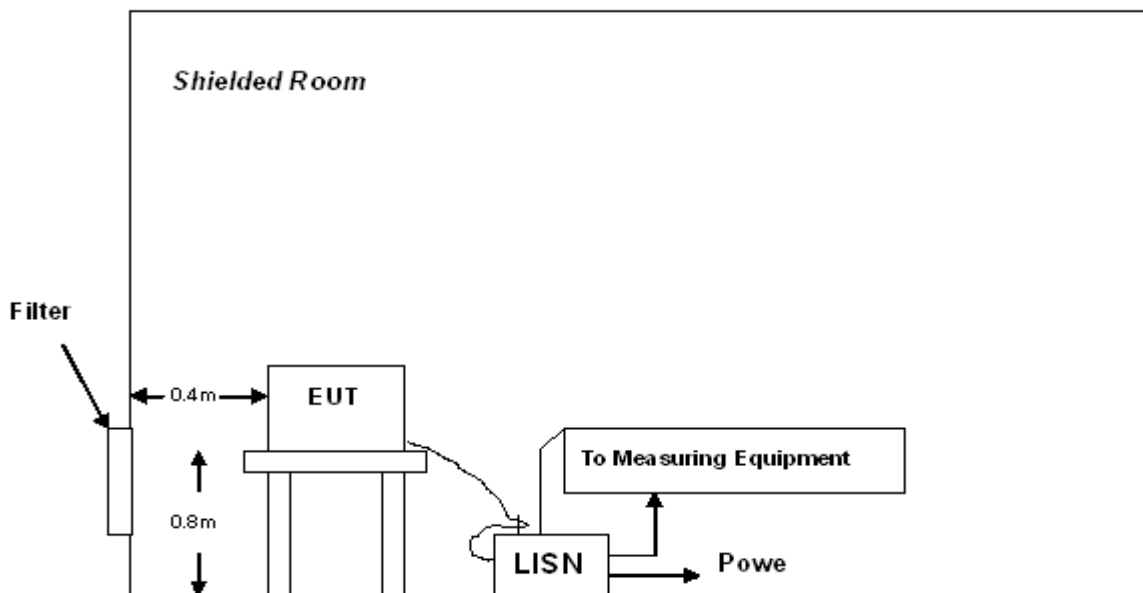

A: Powered through filter

13.3 PRELIMINARY PROCEDURE OF LINE CONDUCTED EMISSION TEST

- 1) The equipment was set up as per the test configuration to simulate typical actual usage per the user's manual. When the EUT is a tabletop system, a wooden table with a height of 0.8 meters is used and is placed on the ground plane as per ANSI C63.4 (see Test Facility for the dimensions of the ground plane used). When the EUT is a floor-standing equipment, it is placed on the ground plane which has a 3-12 mm non-conductive covering to insulate the EUT from the ground plane.
- 2) Support equipment, if needed, was placed as per ANSI C63.4.
- 3) All I/O cables were positioned to simulate typical actual usage as per ANSI C63.4.
- 4) All support equipments received AC120V/60Hz power from a LISN, if any.
- 5) The EUT received power by PC through USB.
- 6) The test program was started. Emissions were measured on each current carrying line of the EUT using a spectrum Analyzer / Receiver connected to the LISN powering the EUT. The LISN has two monitoring points: Line 1 (Hot Side) and Line 2 (Neutral Side). Two scans were taken: one with Line 1 connected to Analyzer / Receiver and Line 2 connected to a 50 ohm load; the second scan had Line 1 connected to a 50 ohm load and Line 2 connected to the Analyzer / Receiver.
- 7) Analyzer / Receiver scanned from 150 kHz to 30MHz for emissions in each of the test modes.
- 8) During the above scans, the emissions were maximized by cable manipulation.
- 9) The following test mode(s) were scanned during the preliminary test:

Then, the EUT configuration and cable configuration of the above highest emission level were recorded for reference of final testing.

13.4 FINAL PROCEDURE OF LINE CONDUCTED EMISSION TEST

- 1) EUT and support equipment was set up on the test bench as per step 2 of the preliminary test.
- 2) A scan was taken on both power lines, Line 1 and Line 2, recording at least the six highest emissions. Emission frequency and amplitude were recorded into a computer in which correction factors were used to calculate the emission level and compare reading to the applicable limit. If EUT emission level was less -2dB to the A.V. limit in Peak mode, then the emission signal was re-checked using Q.P and Average detector.
- 3) The test data of the worst case condition(s) was reported on the Summary Data page.

13.5 TEST RESULT OF LINE CONDUCTED EMISSION TEST

Line Conducted Emission Test Line 1-L

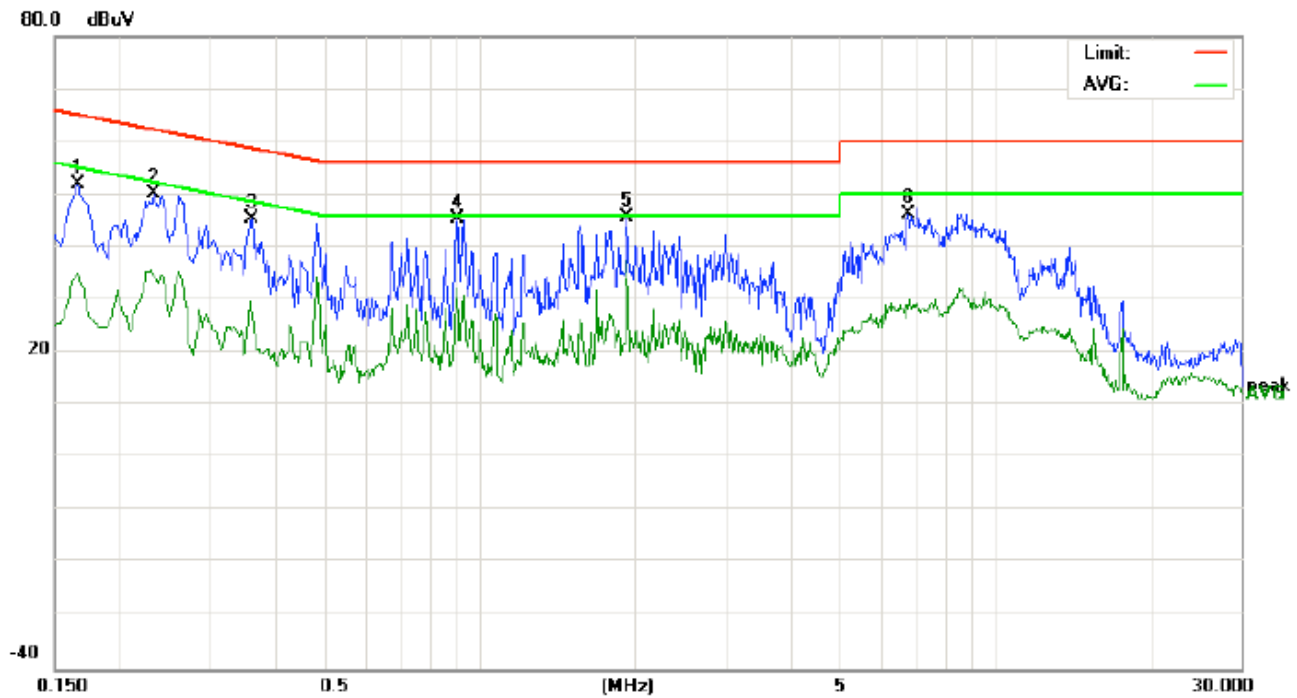

Site: Conduction Phase: **L1** Temperature: 26
 Limit: FCC Class B Conduction(QP) Power: Humidity: 60 %
 EUT: Bluetooth Stereo Headset
 M/N: H-680
 Mode: Bluetooth
 Note:

No.	Freq. (MHz)	Reading_Level (dBuV)			Correct Factor (dB)	Measurement (dBuV)			Limit (dBuV)		Margin (dB)		P/F	Comment
		Peak	QP	AVG		Peak	QP	AVG	QP	AVG	QP	AVG		
1	0.1660	41.86		24.88	10.18	52.04		35.06	65.15	55.15	-13.11	-20.09	P	
2	0.2340	39.76		24.17	10.25	50.01		34.42	62.30	52.30	-12.29	-17.88	P	
3	0.3618	35.15		16.77	10.31	45.46		27.08	58.69	48.69	-13.23	-21.61	P	
4	0.9060	34.95		21.59	10.41	45.36		32.00	56.00	46.00	-10.64	-14.00	P	
5	1.9337	35.34		27.34	10.24	45.58		37.58	56.00	46.00	-10.42	-8.42	P	
6	6.7979	35.76		17.98	10.34	46.10		28.32	60.00	50.00	-13.90	-21.68	P	

Line Conducted Emission Test Line 2-N

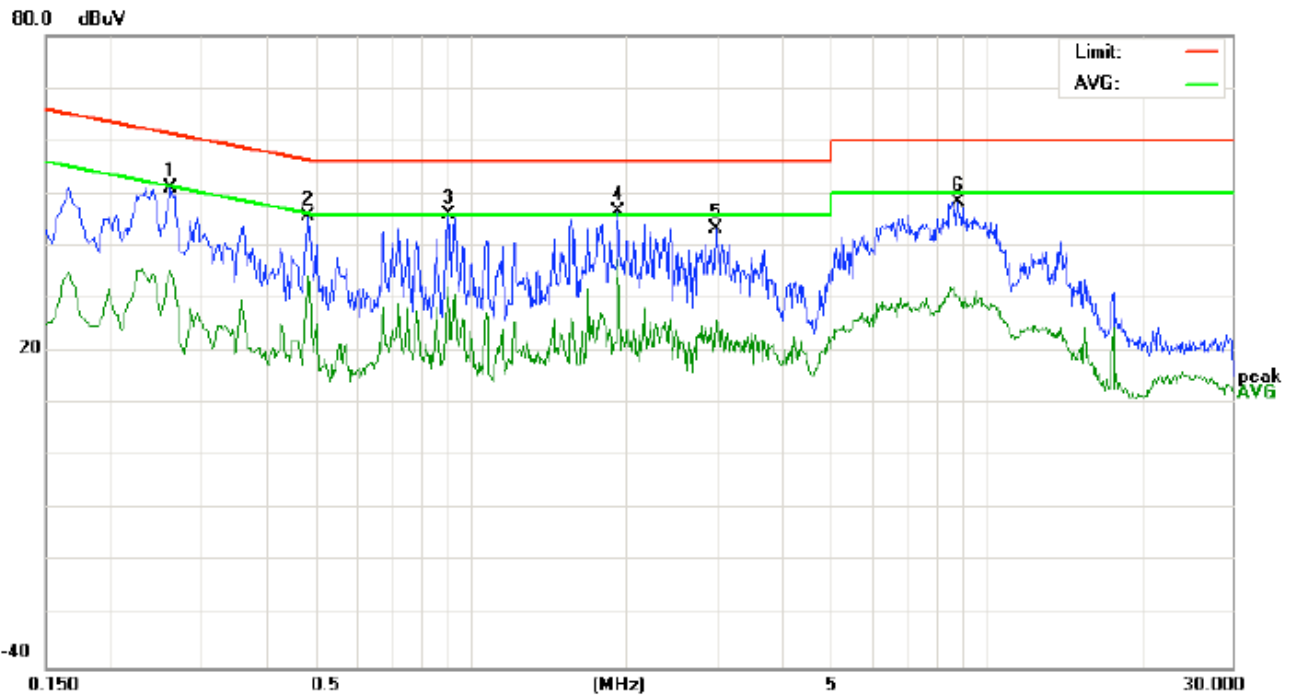

Site: Conduction Phase: *N* Temperature: 26
Limit: FCC Class B Conduction(QP) Power: Humidity: 60 %
EUT: Bluetooth Stereo Headset
M/N: H-680
Mode: Bluetooth
Note:

No.	Freq. (MHz)	Reading_Level (dBuV)			Correct Factor (dB)	Measurement (dBuV)			Limit (dBuV)		Margin (dB)		P/F	Comment
		Peak	QP	AVG		Peak	QP	AVG	QP	AVG	QP	AVG		
1	0.2620	40.71		25.30	10.27	50.98		35.57	61.36	51.36	-10.38	-15.79	P	
2	0.4859	35.18		23.56	10.39	45.57		33.95	56.24	46.24	-10.67	-12.29	P	
3	0.9060	35.45		21.59	10.41	45.86		32.00	56.00	46.00	-10.14	-14.00	P	
4	1.9339	36.34		27.34	10.24	46.58		37.58	56.00	46.00	-9.42	-8.42	P	
5	2.9780	32.75		14.95	10.54	43.29		25.49	56.00	46.00	-12.71	-20.51	P	
6	8.7779	38.12		20.16	10.27	48.39		30.43	60.00	50.00	-11.61	-19.57	P	

APPENDIX I
PHOTOGRAPHS OF THE EUT
TOP VIEW OF EUT



BOTTOM VIEW OF EUT



RIGHT VIEW OF EUT



LEFT VIEW OF EUT



FRONT VIEW OF EUT



BACK VIEW OF EUT



TOTAL VIEW OF EUT



INTERNAL VIEW OF EUT-1



INTERNAL VIEW OF EUT-2

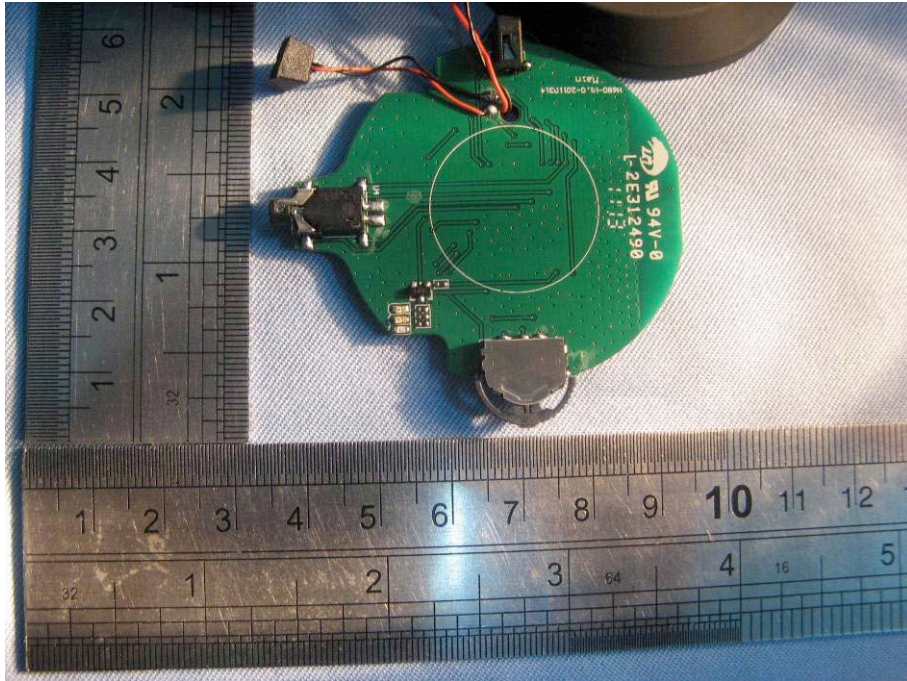

INTERNAL VIEW OF EUT-3

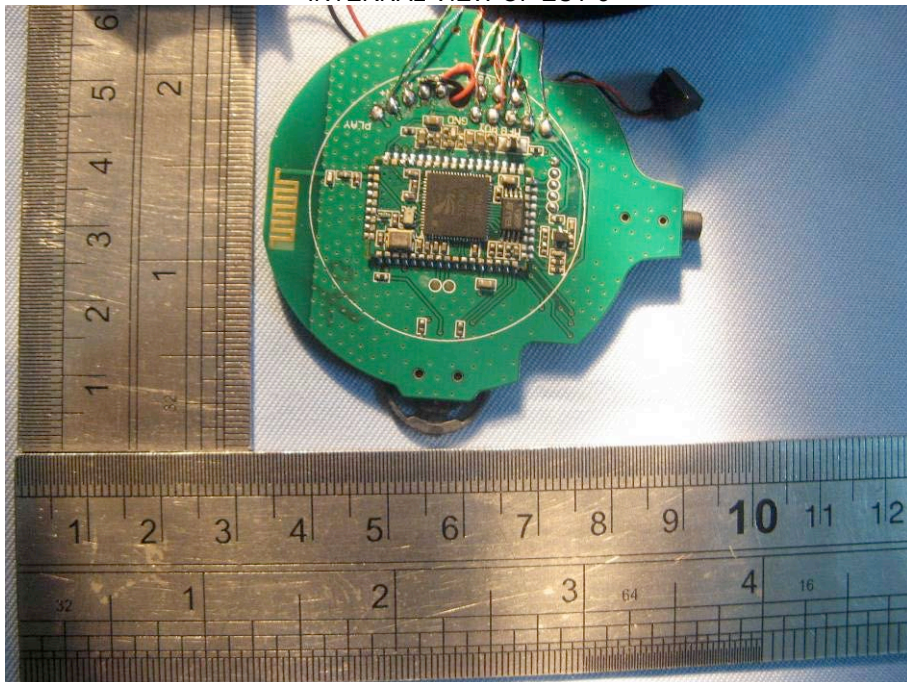

INTERNAL VIEW OF EUT-4



INTERNAL VIEW OF EUT-5

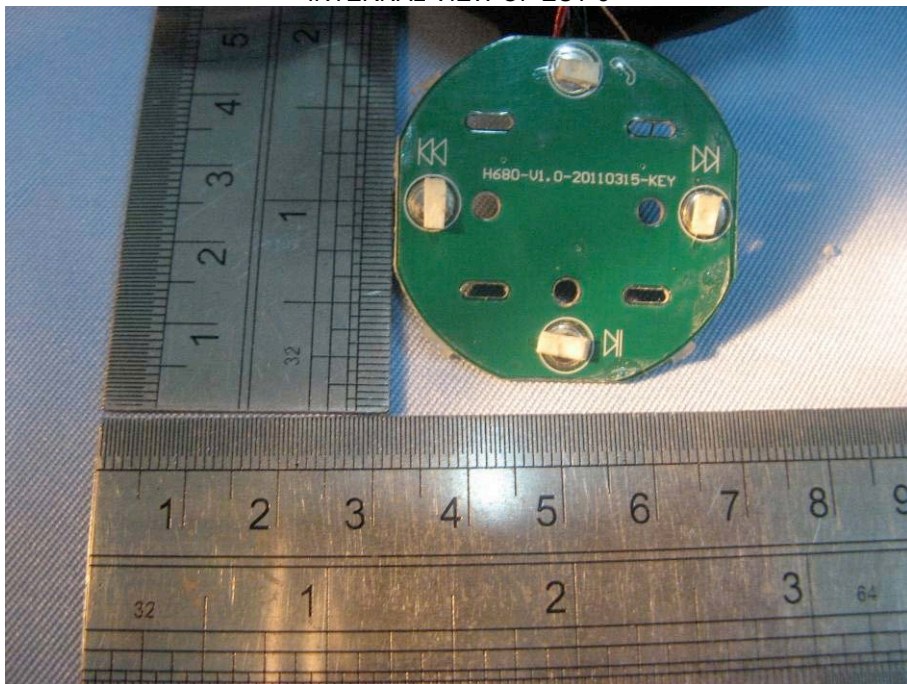

**APPENDIX II
PHOTOGRAPHS OF THE TEST SETUP
CONDUCTED EMISSION**



RADIATED EMISSION



----END OF REPORT----