

FCC Radio Test Report

FCC ID: XDQN82

This report concerns: Original Grant

Project No. : 2207G005
Equipment : POS Terminal
Brand Name : NEXGO
Test Model : N82
Series Model : N/A
Applicant : Shenzhen Xinguodu Technology Co., Ltd.
Address : 17B JinSong Mansion, Terra Industrial & Trade Park Chegongmiao, Futian District, Shenzhen, China
Manufacturer : Shenzhen Xinguodu Technology Co., Ltd.
Address : 17B JinSong Mansion, Terra Industrial & Trade Park Chegongmiao, Futian District, Shenzhen, China
Factory : Shenzhen Xinguodu Technology Co., Ltd. Manufacture Branch.
Address : Building C, Dagang Industrial Park, Changzhen Community, Gongming Office, Guangming New District, Shenzhen, Guangdong, China.
Date of Receipt : Jul. 05, 2022
Date of Test : Jul. 08, 2022 ~ Jul. 26, 2022
Issued Date : Aug. 09, 2022
Report Version : R01
Test Sample : Engineering Sample No.: DG202207075 for radiated, DG202207076 for conducted.
Standard(s) : 47 CFR FCC Part 24 Subpart E
47 CFR FCC Part 2
ANSI C63.26-2015
ANSI/TIA/EIA-603-E-2016
FCC KDB 971168 D01 Power Meas License Digital Systems v03r01

The above equipment has been tested and found compliance with the requirement of the relative standards by BTL Inc.

Edward Li

Prepared by : Edward Li

Steven Lu

Approved by : Steven Lu



TESTING CERT #5123.02

BTL Inc.

No. 3 Jinshagang 1st Rd. Shixia, Dalang Town Dongguan City, Guangdong 523792 People's Republic of China.

Tel: +86-769-8318-3000 Web: www.newbtl.com Service mail: btl_qa@newbtl.com

Declaration

BTL represents to the client that testing is done in accordance with standard procedures as applicable and that test instruments used has been calibrated with standards traceable to international standard(s) and/or national standard(s).

BTL's reports apply only to the specific samples tested under conditions. It is manufacture's responsibility to ensure that additional production units of this model are manufactured with the identical electrical and mechanical components. **BTL** shall have no liability for any declarations, inferences or generalizations drawn by the client or others from **BTL** issued reports.

The report must not be used by the client to claim product certification, approval, or endorsement by NIST, A2LA, or any agency of the U.S. Government.

This report is the confidential property of the client. As a mutual protection to the clients, the public and ourselves, the test report shall not be reproduced, except in full, without our written approval.

BTL's laboratory quality assurance procedures are in compliance with the **ISO/IEC 17025** requirements, and accredited by the conformity assessment authorities listed in this test report.

BTL is not responsible for the sampling stage, so the results only apply to the sample as received.

The information, data and test plan are provided by manufacturer which may affect the validity of results, so it is manufacturer's responsibility to ensure that the apparatus meets the essential requirements of applied standards and in all the possible configurations as representative of its intended use.

Limitation

For the use of the authority's logo is limited unless the Test Standard(s)/Scope(s)/Item(s) mentioned in this test report is (are) included in the conformity assessment authorities acceptance respective.

Please note that the measurement uncertainty is provided for informational purpose only and is not use in determining the Pass/Fail results.

Table of Contents	Page
REPORT ISSUED HISTORY	5
1 . SUMMARY OF TEST RESULTS	6
1.1 TEST FACILITY	7
1.2 MEASUREMENT UNCERTAINTY	7
1.3 TEST ENVIRONMENT CONDITIONS	8
2 . GENERAL INFORMATION	9
2.1 GENERAL DESCRIPTION OF EUT	9
2.2 DESCRIPTION OF TEST MODES	11
2.3 BLOCK DIAGRAM SHOWING THE CONFIGURATION OF SYSTEM TESTED	13
2.4 DESCRIPTION OF SUPPORT UNITS	13
3 . TEST RESULT	14
3.1 OUTPUT POWER MEASUREMENT	14
3.1.1 LIMIT	14
3.1.2 TEST PROCEDURE	14
3.1.3 TEST SETUP LAYOUT	14
3.1.4 TEST DEVIATION	14
3.1.5 TEST RESULTS	14
3.2 OCCUPIED BANDWIDTH MEASUREMENT	15
3.2.1 TEST PROCEDURE	15
3.2.2 TEST SETUP LAYOUT	15
3.2.3 TEST DEVIATION	15
3.2.4 TEST RESULTS	15
3.3 CONDUCTED SPURIOUS EMISSIONS MEASUREMENT	16
3.3.1 LIMIT	16
3.3.2 TEST PROCEDURES	16
3.3.3 TEST SETUP LAYOUT	16
3.3.4 TEST DEVIATION	16
3.3.5 TEST RESULTS	16
3.4 RADIATED SPURIOUS EMISSIONS MEASUREMENT	17
3.4.1 LIMIT	17
3.4.2 TEST PROCEDURES	17
3.4.3 TEST SETUP LAYOUT	18
3.4.4 TEST DEVIATION	19
3.4.5 TEST RESULTS (9KHZ TO 30MHZ)	19
3.4.6 TEST RESULTS (30MHZ TO 1000MHZ)	19
3.4.7 TEST RESULTS (ABOVE 1000MHZ)	19
3.5 BAND EDGE MEASUREMENT	20
3.5.1 LIMIT	20
3.5.2 TEST PROCEDURES	20

Table of Contents	Page
3.5.3 TEST SETUP LAYOUT	20
3.5.4 TEST DEVIATION	20
3.5.5 TEST RESULTS	20
3.6 PEAK TO AVERAGE RATIO MEASUREMENT	21
3.6.1 LIMIT	21
3.6.2 TEST PROCEDURES	21
3.6.3 TEST SETUP LAYOUT	21
3.6.4 TEST DEVIATION	21
3.6.5 TEST RESULTS	21
3.7 FREQUENCY STABILITY MEASUREMENT	22
3.7.1 LIMIT	22
3.7.2 TEST PROCEDURES	22
3.7.3 TEST SETUP LAYOUT	22
3.7.4 TEST DEVIATION	22
3.7.5 TEST RESULTS	22
4. LIST OF MEASUREMENT EQUIPMENTS	23
5. EUT TEST PHOTO	25
APPENDIX A - OUTPUT POWER	28
APPENDIX B - OCCUPIED BANDWIDTH	37
APPENDIX C - CONDUCTED SPURIOUS EMISSIONS	47
APPENDIX D - RADIATED SPURIOUS EMISSIONS (9KHZ TO 30MHZ)	51
APPENDIX E - RADIATED SPURIOUS EMISSIONS (30MHZ TO 1000MHZ)	53
APPENDIX F - RADIATED SPURIOUS EMISSIONS (ABOVE 1000MHZ)	57
APPENDIX G - BAND EDGE	63
APPENDIX H - PEAK TO AVERAGE RATIO	72
APPENDIX I - FREQUENCY STABILITY	82

REPORT ISSUED HISTORY

Report No.	Version	Description	Issued Date	Note
BTL-FCCP-2-2207G005	R00	Original Report.	Aug. 03, 2022	Invalid
BTL-FCCP-2-2207G005	R01	Added IMEI Code.	Aug. 09, 2022	Valid

1. SUMMARY OF TEST RESULTS

Test procedures according to the technical standard(s):

FCC Part 24 Subpart E & Part 2			
Standard(s) Section	Test Item	Judgment	Remark
2.1046 24.232(c)	Equivalent Isotropic Radiated Power	PASS	-----
2.1049	Occupied Bandwidth	PASS	-----
2.1051 24.238(a)	Conducted Spurious Emissions	PASS	-----
2.1053 24.238(a)	Radiated Spurious Emissions	PASS	-----
2.1051 24.238(a)	Band Edge Measurements	PASS	-----
24.232(d)	Peak To Average Ratio	PASS	-----
2.1055 24.235	Frequency Stability	PASS	-----

Note:

- (1) "N/A" denotes test is not applicable in this test report.
- (2) For radiated spurious emissions below 1 GHz test, all adapters had been pre-tested and in this report only recorded the worst adapter (Model: STC-A520A-Z).

1.1 TEST FACILITY

The test facilities used to collect the test data of radiated in this report is at the location of No. 3 Jinshagang 1st Rd. Shixia, Dalang Town Dongguan City, Guangdong 523792 People's Republic of China.

The test facilities used to collect the test data of conducted in this report is at the location of Room 108, Building 2, No.1, Yile Road, Songshan Lake Zone, Dongguan City, Guangdong, People's Republic of China.

BTL's Test Firm Registration Number for FCC: 357015

BTL's Designation Number for FCC: CN1240

1.2 MEASUREMENT UNCERTAINTY

ISO/IEC 17025 requires that an estimate of the measurement uncertainties associated with the emissions test results be included in the report. The measurement uncertainties given below are based on a 95% confidence level (based on a coverage factor (k=2))

The BTL measurement uncertainty as below table:

A. Radiated Measurement:

Test Site	Method	Measurement Frequency Range	U,(dB)
DG-CB01	CISPR	9kHz ~ 30MHz	2.36

Test Site	Method	Measurement Frequency Range	Ant. H / V	U,(dB)
DG-CB03	CISPR	30MHz ~ 200MHz	V	4.36
		30MHz ~ 200MHz	H	3.32
		200MHz ~ 1,000MHz	V	4.08
		200MHz ~ 1,000MHz	H	3.96
		1GHz ~ 6GHz	-	3.80
		6GHz ~ 18GHz	-	4.82
		18GHz ~ 26.5 GHz	-	3.62

B. Other Measurement:

Parameter	Uncertainty
Spectrum Bandwidth	±3.8 %
Maximum Output Power	±0.95 dB
Power Spectral Density	±0.86 dB
Frequency Stability	±0.16 dB
Temperature	±0.08 °C
Time	±0.58 %
Supply voltages	±0.3 %



Note: Unless specifically mentioned, the uncertainty of measurement has not been taken into account to declare the compliance or non-compliance to the specification.

1.3 TEST ENVIRONMENT CONDITIONS

Test Item	Temperature	Humidity	Test Voltage	Tested By
Output Power & EIRP	24.5°C	43%	DC 3.7V	Jelly Huang
Occupied Bandwidth	24.5°C	43%	DC 3.7V	Jelly Huang
Conducted Spurious Emissions	24.5°C	43%	DC 3.7V	Jelly Huang
Radiated Spurious Emissions (9 kHz to 30 MHz)	25°C	58%	AC 120V/60Hz	Farun Liang
Radiated Spurious Emissions (30 MHz to 1000 MHz)	24°C	50%	AC 120V/60Hz	Berton Luo
Radiated Spurious Emissions (Above 1000 MHz)	24°C	50%	AC 120V/60Hz	Berton Luo
Band Edge	24.5°C	43%	DC 3.7V	Jelly Huang
Peak to Average Ratio	24.5°C	43%	DC 3.7V	Jelly Huang
Frequency Stability	Normal & Extreme	43%	Normal & Extreme	Jelly Huang

2. GENERAL INFORMATION

2.1 GENERAL DESCRIPTION OF EUT

Equipment	POS Terminal				
Brand Name	NEXGO				
Test Model	N82				
Series Model	N/A				
Model Difference(s)	N/A				
Hardware Version	V1.0CI				
Software Version	XGD OS V1.0				
Power Source	1# DC voltage supplied from AC adapter. (1) Model: RJ23B-W050200EU (2) Model: STC-A520A-Z 2# Supplied from battery. Model: GX02 3# Supplied from USB port.				
Power Rating	1# (1) I/P: 100-240V~ 50/60Hz 0.3A O/P: 5.0V  2.0A 10.0W (2) I/P: 100-240V~ 50/60Hz 400mA O/P: 5.0V  2000mA 2# DC 3.7V, Rated Capacity: 5200mAh 19.24Wh 3# DC 5V				
IMEI Code	868079060000069, 868079060000085				
Modulation Type	GPRS		GMSK		
	EDGE		GMSK, 8PSK		
	WCDMA/HSDPA/HSUPA		UL: BPSK, QPSK DL: BPSK, QPSK		
	LTE		UL: QPSK, 16QAM, 64QAM DL: QPSK, 16QAM, 64QAM		
Max. EIRP	GPRS 1900		GMSK	32.25	dBm
	EDGE 1900		8PSK	28.93	dBm
	WCDMA Band II		QPSK	25.00	dBm
	HSDPA Band II		QPSK	23.78	dBm
	HSUPA Band II		QPSK	23.13	dBm
	LTE	Channel Bandwidth (MHz)	QPSK (dBm)	16QAM (dBm)	64QAM (dBm)
	Band 2	1.4	25.97	24.76	24.12
		3	25.70	24.97	23.81
		5	25.68	25.03	23.70
		10	25.77	25.00	23.82
15		25.60	24.86	23.69	
	20	26.00	25.48	23.80	

Note:

1. For a more detailed features description, please refer to the manufacturer's specifications or the user's manual.

2. Channel List:

PCS 1900				
Test Frequency ID	UARFCN	Frequency of Uplink (MHz)	UARFCN	Frequency of Downlink (MHz)
Low Range	512	1850.2	528	1930.2
Mid Range	661	1880	677	1960
High Range	810	1909.8	826	1989.8

WCDMA Band II				
Test Frequency ID	UARFCN	Frequency of Uplink (MHz)	UARFCN	Frequency of Downlink (MHz)
Low Range	9262	1852.4	9662	1932.4
Mid Range	9400	1880.0	9800	1960.0
High Range	9538	1907.6	9938	1987.6

LTE Band 2					
Test Frequency ID	Bandwidth (MHz)	N _{UL}	Frequency of Uplink (MHz)	N _{DL}	Frequency of Downlink (MHz)
Low Range	1.4	18607	1850.7	607	1930.7
	3	18615	1851.5	615	1931.5
	5	18625	1852.5	625	1932.5
	10	18650	1855	650	1935
	15	18675	1857.5	675	1937.5
	20	18700	1860	700	1940
Mid Range	1.4/3/5/10/15/20	18900	1880	900	1960
High Range	1.4	19193	1909.3	1193	1989.3
	3	19185	1908.5	1185	1988.5
	5	19175	1907.5	1175	1987.5
	10	19150	1905	1150	1985
	15	19125	1902.5	1125	1982.5
	20	19100	1900	1100	1980

3. Table for Filed Antenna:

Brand	P/N	Antenna Type	Connector	Gain (dBi)	Note
	SZ22043IB75-1	FPC	N/A	1.63	PCS 1900
				1.63	WCDMA Band II
				1.63	LTE Band 2

Note: The antenna gain is provided by the manufacturer.

2.2 DESCRIPTION OF TEST MODES

Following mode(s) is (were) found to be the worst case(s) and selected for the final test.

GSM MODE			
Test Item	Available Channel	Tested Channel	Mode
Output Power & EIRP	512 to 810	512, 661, 810	GPRS, EDGE
Occupied Bandwidth	512 to 810	512, 661, 810	GPRS, EDGE
Conducted Spurious Emissions	512 to 810	661	GPRS, EDGE
Radiated Spurious Emissions	512 to 810	661	GPRS
Band Edge	512 to 810	512, 810	GPRS, EDGE
Peak to Average Ratio	512 to 810	512, 661, 810	GPRS, EDGE
Frequency Stability	512 to 810	512, 810	GPRS

WCDMA BAND II MODE			
Test Item	Available Channel	Tested Channel	Mode
Output Power & EIRP	9262 to 9538	9262, 9400, 9538	WCDMA, HSDPA, HSUPA
Occupied Bandwidth	9262 to 9538	9262, 9400, 9538	WCDMA
Conducted Spurious Emissions	9262 to 9538	9400	WCDMA
Radiated Spurious Emissions	9262 to 9538	9400	WCDMA
Band Edge	9262 to 9538	9262, 9538	WCDMA
Peak To Average Ratio	9262 to 9538	9262, 9400, 9538	WCDMA
Frequency Stability	9262 to 9538	9262, 9538	WCDMA

LTE BAND 2 MODE					
Test Item	Available Channel	Tested Channel	Channel Bandwidth	Modulation	Mode
Output Power & EIRP	18607 to 19193	18607, 18900, 19193	1.4MHz	QPSK, 16QAM, 64QAM	1RB/3RB/6RB
	18615 to 19185	18615, 18900, 19185	3MHz	QPSK, 16QAM, 64QAM	1RB/8RB/15RB
	18625 to 19175	18625, 18900, 19175	5MHz	QPSK, 16QAM, 64QAM	1RB/12RB/25RB
	18650 to 19150	18650, 18900, 19150	10MHz	QPSK, 16QAM, 64QAM	1RB/25RB/50RB
	18675 to 19125	18675, 18900, 19125	15MHz	QPSK, 16QAM, 64QAM	1RB/36RB/75RB
	18700 to 19100	18700, 18900, 19100	20MHz	QPSK, 16QAM, 64QAM	1RB/50RB/100RB
Occupied Bandwidth	18607 to 19193	18607, 18900, 19193	1.4MHz	QPSK, 16QAM, 64QAM	6RB
	18615 to 19185	18615, 18900, 19185	3MHz	QPSK, 16QAM, 64QAM	15RB
	18625 to 19175	18625, 18900, 19175	5MHz	QPSK, 16QAM, 64QAM	25RB
	18650 to 19150	18650, 18900, 19150	10MHz	QPSK, 16QAM, 64QAM	50RB
	18675 to 19125	18675, 18900, 19125	15MHz	QPSK, 16QAM, 64QAM	75RB
	18700 to 19100	18700, 18900, 19100	20MHz	QPSK, 16QAM, 64QAM	100RB
Conducted Spurious Emissions	18607 to 19193	18900	1.4 MHz	QPSK	1RB
	18625 to 19175	18900	5MHz	QPSK	1RB
	18700 to 19100	18900	20MHz	QPSK	1RB
Radiated Spurious Emissions	18607 to 19193	18900	1.4 MHz	QPSK	1RB
	18625 to 19175	18900	5MHz	QPSK	1RB
	18700 to 19100	18900	20MHz	QPSK	1RB
Band Edge	18607 to 19193	18607, 19193	1.4MHz	QPSK	1RB/6RB
	18615 to 19185	18615, 19185	3MHz	QPSK	1RB/15RB
	18625 to 19175	18625, 19175	5MHz	QPSK	1RB/25RB
	18650 to 19150	18650, 19150	10MHz	QPSK	1RB/50RB
	18675 to 19125	18675, 19125	15MHz	QPSK	1RB/75RB
	18700 to 19100	18700, 19100	20MHz	QPSK	1RB/100RB
Peak To Average Ratio	18607 to 19193	18607, 18900, 19193	1.4MHz	QPSK, 16QAM, 64QAM	1RB
	18615 to 19185	18615, 18900, 19185	3MHz	QPSK, 16QAM, 64QAM	1RB
	18625 to 19175	18625, 18900, 19175	5MHz	QPSK, 16QAM, 64QAM	1RB
	18650 to 19150	18650, 18900, 19150	10MHz	QPSK, 16QAM, 64QAM	1RB
	18675 to 19125	18675, 18900, 19125	15MHz	QPSK, 16QAM, 64QAM	1RB
	18700 to 19100	18700, 18900, 19100	20MHz	QPSK, 16QAM, 64QAM	1RB
Frequency Stability	18700 to 19100	18700, 19100	20MHz	QPSK	100RB

2.3 BLOCKDIGRAMSHOWINGTHECONFIGURATIONOFSYSTEMTESTED

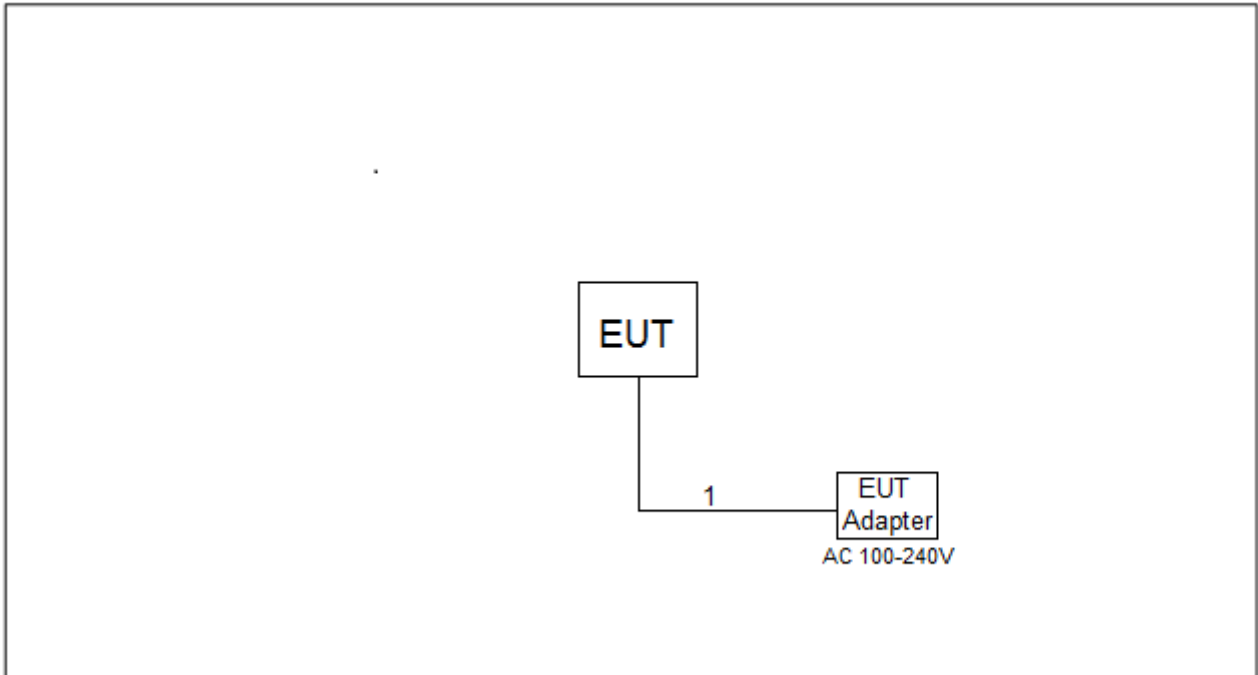

2.4 DESCRIPTION OF SUPPORT UNITS

The EUT has been tested as an independent unit together with other necessary accessories or support units. The following support units or accessories were used to form a representative test configuration during the tests.

Item	Equipment	Brand	Model No.	Series No.
-	-	-	-	-

Item	Cable Type	Shielded Type	Ferrite Core	Length
1	USB Cable	NO	NO	1.2m

3. TEST RESULT

3.1 OUTPUT POWER MEASUREMENT

3.1.1 LIMIT

Mobile / Portable station are limited to 2 watts e.i.r.p.

3.1.2 TEST PROCEDURE

The testing follows FCC KDB 971168 v03r01 Section 5.

EIRP:

$EIRP = \text{Output Power} + \text{Antenan gain}$

Output Power:

The EUT was set up for the maximum power with GSM, GPRS, EDGE, WCDMA and LTE link data modulation and link up with simulator. Set the EUT to transmit under low, middle and high channel and record the power level shown on simulator.

3.1.3 TEST SETUP LAYOUT

Output Power Measurement

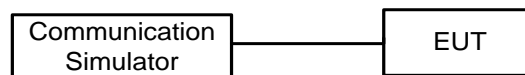

3.1.4 TEST DEVIATION

No deviation.

3.1.5 TEST RESULTS

Please refer to the APPENDIX A.

3.2 OCCUPIED BANDWIDTH MEASUREMENT

3.2.1 TEST PROCEDURE

The testing follows FCC KDB 971168 v03r01 Section 4.

1. The EUT makes a call to the communication simulator. All measurements were done at low, middle and high operational frequency range. The communication simulator station system controlled a EUT to export maximum output power under transmission mode and specific channel frequency. Use OBW measurement function of Spectrum analyzer to measure 99 % occupied bandwidth and 26dB bandwidth.
2. The EUT was connected to spectrum analyzer and system simulator via a power divider.
3. $RBW=(1\% \sim 5\%)*EBW$
 $VBW \geq 3*RBW$
4. Set spectrum analyzer with Peak detector.

3.2.2 TEST SETUP LAYOUT

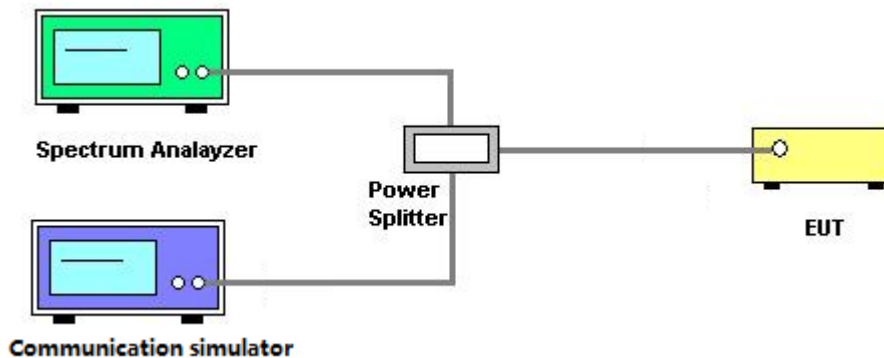

3.2.3 TEST DEVIATION

No deviation.

3.2.4 TEST RESULTS

Please refer to the APPENDIX B.

3.3 CONDUCTED SPURIOUS EMISSIONS MEASUREMENT

3.3.1 LIMIT

The power of any emission outside of the authorized operating frequency ranges must be attenuated below the transmitting power (P) by a factor of at least $43 + 10 \log(P)$ dB. The emission limit equal to -13dBm.

3.3.2 TEST PROCEDURES

The testing follows FCC KDB 971168 v03r01 Section 6.

1. The EUT was connected to spectrum analyzer and system simulator via a power divider.
2. The band edges of low and high channels for the highest RF powers were measured. Set RBW $\geq 1\%$ EBW in the 1MHz band immediately outside and adjacent to the band edge.
3. Set spectrum analyzer with Peak detector.
4. The RF fundamental frequency should be excluded against the limit line in the operating frequency band.

3.3.3 TEST SETUP LAYOUT

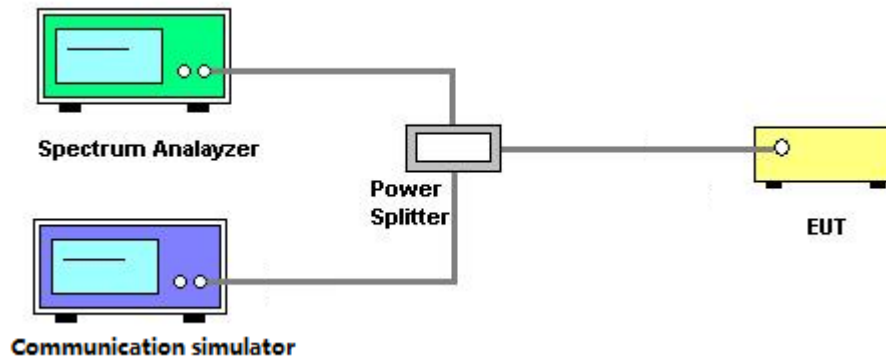

3.3.4 TEST DEVIATION

No deviation.

3.3.5 TEST RESULTS

Please refer to the APPENDIX C.

3.4 RADIATED SPURIOUS EMISSIONS MEASUREMENT

3.4.1 LIMIT

The power of any emission outside of the authorized operating frequency ranges must be attenuated below the transmitting power (P) by a factor of at least $43 + 10 \log(P)$ dB. The emission limit equal to -13dBm.

3.4.2 TEST PROCEDURES

The testing follows FCC KDB 971168 v03r01 Section 6.2.

1. In the semi-anechoic chamber, EUT placed on the 0.8m height of Turn Table, rotated the table around 360 degrees to search the maximum radiation power and receiver antenna shall be rotated vertical and horizontal polarization and moved height from 1m to 4m to find the maximum polar radiated power. The "Read Value" is the spectrum reading the maximum power value.
2. The substitution horn antenna is substituted for EUT at the same position and signals generator export the CW signal to the substitution antenna via a TX cable. Rotated the Turn Table and moved receiving antenna to find the maximum radiation power. Adjust output power level of S.G to get a Value of spectrum reading equal to "Read Value " of step a. Record the power level of S.G
3. $EIRP = \text{Output power level of S.G} - \text{TX cable loss} + \text{Antenna gain of substitution horn.}$
4. ERP can be calculated form $EIRP$ by subtracting the gain of dipole, $ERP = EIPR - 2.15\text{dBi.}$
5. The resolution bandwidth and video bandwidth of test receiver/spectrum analyzer is 1MHz/3MHz.

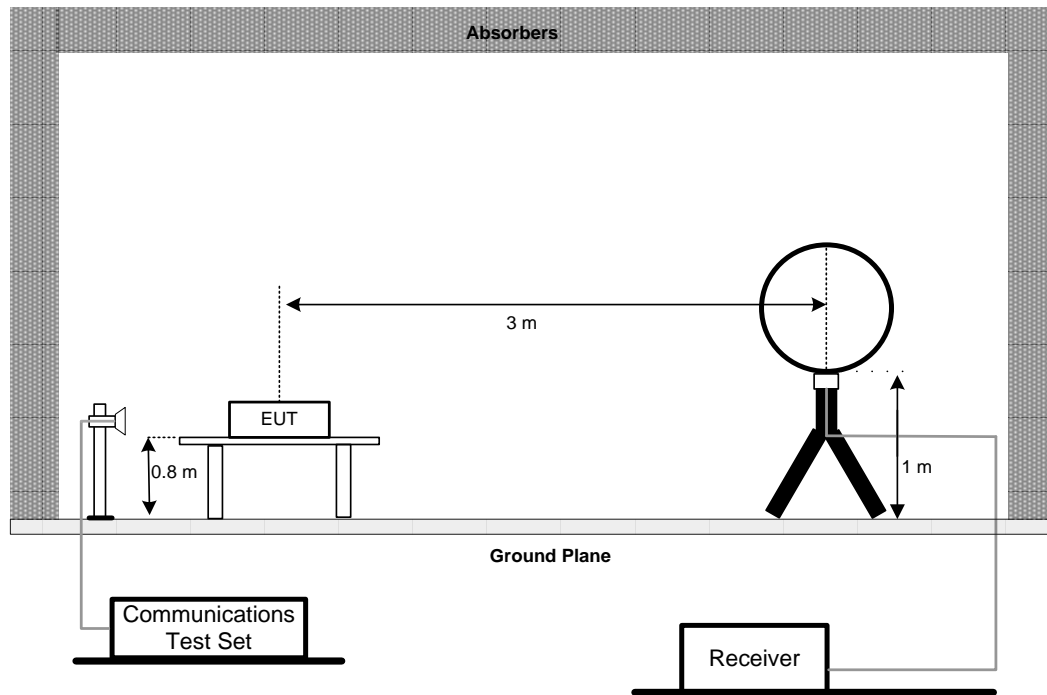
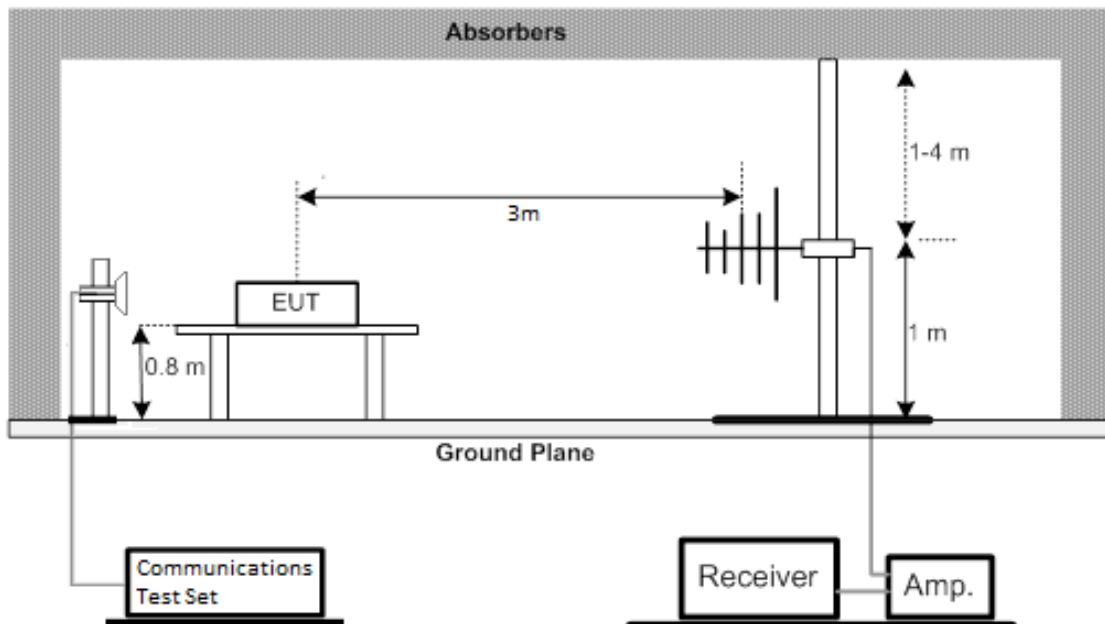
3.4.3 TEST SETUP LAYOUT**Below 30MHz****30MHz to 1000MHz**

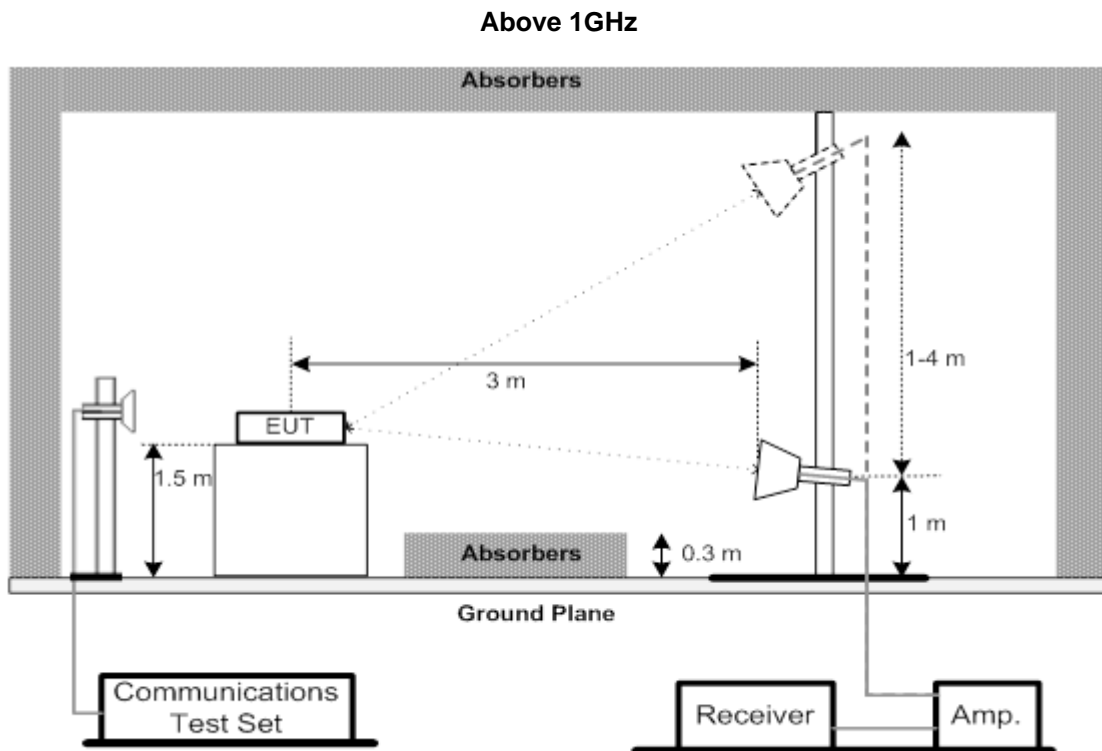

3.4.4 TEST DEVIATION

No deviation.

3.4.5 TEST RESULTS (9KHZ TO 30MHZ)

Please refer to the APPENDIX D.

3.4.6 TEST RESULTS (30MHZ TO 1000MHZ)

Please refer to the APPENDIX E.

3.4.7 TEST RESULTS (ABOVE 1000MHZ)

Please refer to the APPENDIX F.

3.5 BAND EDGE MEASUREMENT

3.5.1 LIMIT

A Power of any emission outside of the authorized operating frequency ranges must be attenuated below the transmitting power (P) by a factor of at least $43 + 10 \log(P)$ dB. In the 1 MHz bands immediately outside and adjacent to the frequency block a resolution bandwidth of at least one percent of the emission bandwidth of the fundamental emission of the transmitter may be employed.

3.5.2 TEST PROCEDURES

The testing follows FCC KDB 971168 v03r01 Section 6.

1. All measurements were done at low and high operational frequency range.
2. Record the max trace plot into the test report.

3.5.3 TEST SETUP LAYOUT

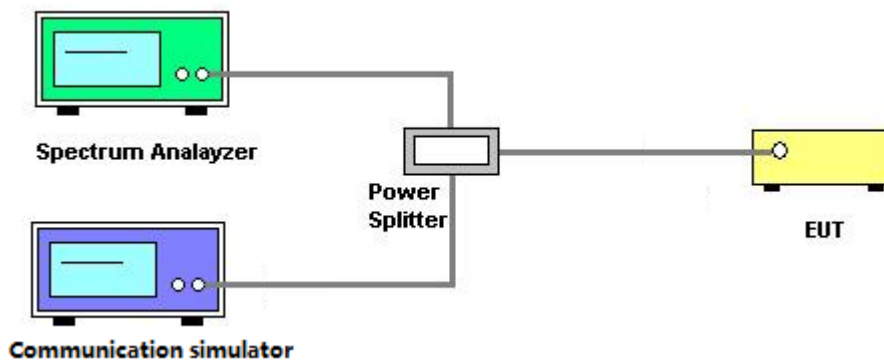

3.5.4 TEST DEVIATION

No deviation.

3.5.5 TEST RESULTS

Please refer to the APPENDIX G.

3.6 PEAK TO AVERAGE RATIO MEASUREMENT

3.6.1 LIMIT

In measuring transmissions in this band using an average power technique, the peak to-average ratio (PAR) of the transmission may not exceed 13 dB.

3.6.2 TEST PROCEDURES

The testing follows FCC KDB 971168 v03r01 Section 5.7.

1. Set resolution/measurement bandwidth \geq signal's occupied bandwidth;
2. Set the number of counts to a value that stabilizes the measured CCDF curve;
3. Record the maximum PAPR level associated with a probability of 0.1%.

3.6.3 TEST SETUP LAYOUT

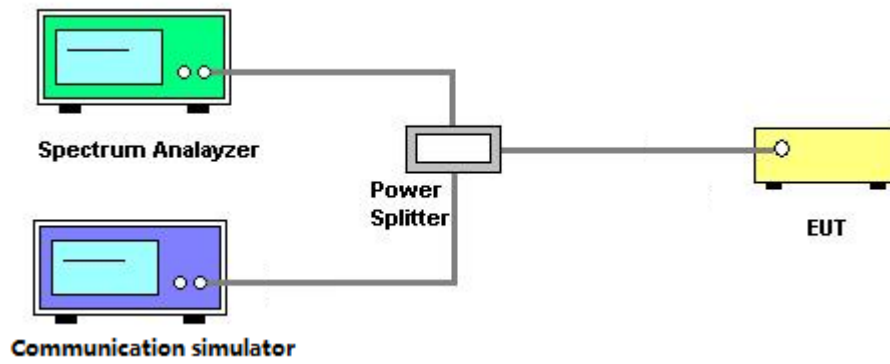

3.6.4 TEST DEVIATION

No deviation.

3.6.5 TEST RESULTS

Please refer to the APPENDIX H.

3.7 FREQUENCY STABILITY MEASUREMENT

3.7.1 LIMIT

The frequency stability shall be sufficient to ensure that the fundamental emission stays within the authorized frequency block.

3.7.2 TEST PROCEDURES

The testing follows ANSI C63.26-2015 Section 5.6.

1. A reference point shall be established at the applicable unwanted emissions limit using a RBW equal to the RBW required by the unwantedemissions specification of the applicable regulatory standard. These reference points measuredusing the lowest and highest channel of operation shall be identified as f L and f H respectively. The worst-case frequency offset determined in the above methods shall be added or subtracted from the values of f L and f H and the resulting frequencies must remain within the band.
2. The EUT was set up in the thermal chamber and connected with the system simulator.
3. With power OFF, the temperature was decreased to -30°C and the EUT was stabilized before testing. Power was applied and the maximum change in frequency was recorded within one minute.
4. With power OFF, the temperature was raised in 10°C step up to 50°C. The EUT was stabilized at each step for at least half an hour. Power was applied and the maximum frequency change was recorded within one minute.

3.7.3 TEST SETUP LAYOUT

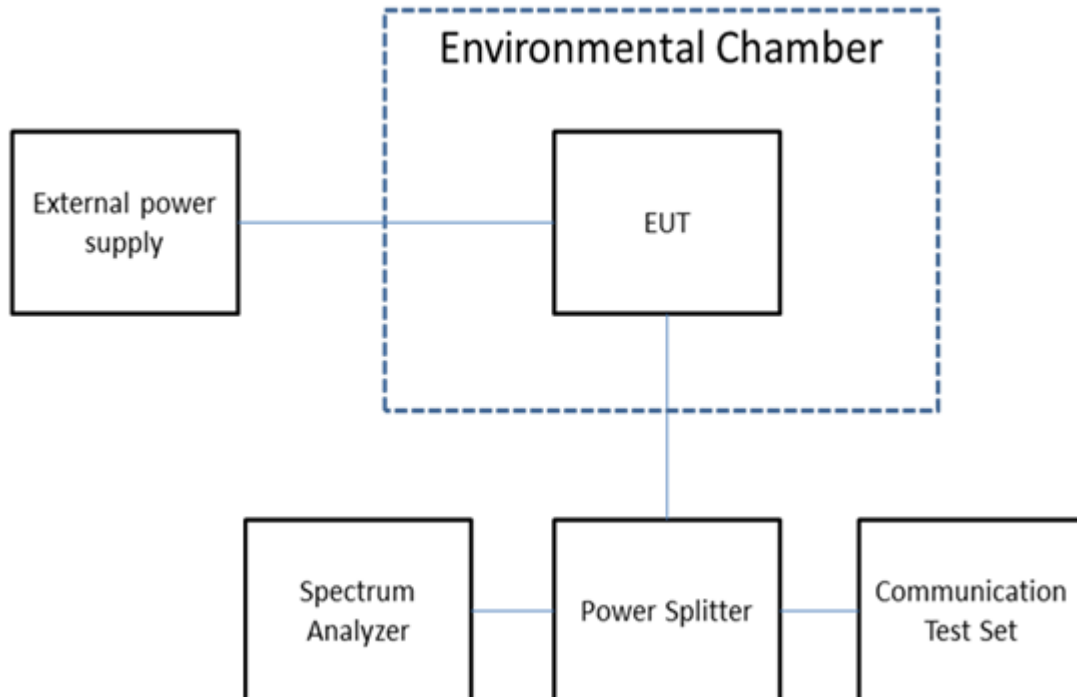

3.7.4 TEST DEVIATION

No deviation.

3.7.5 TEST RESULTS

Please refer to the APPENDIX I.

4. LIST OF MEASUREMENT EQUIPMENTS

Radiated Emissions - 9 kHz to 30 MHz					
Item	Kind of Equipment	Manufacturer	Type No.	Serial No.	Calibrated until
1	MXE EMI Receiver	Keysight	N9038A	MY56400091	Jan. 22, 2023
2*	Active Loop Antenna	R&S	HFH2-Z2	830749/020	Aug. 23, 2024
3	Cable	N/A	RG 213/U(9kHz~1GHz)	N/A	Jun. 17, 2023
4	Measurement Software	Farad	EZ-EMC Ver.NB-03A1-01	N/A	N/A
5	wideband radio communication tester	R&S	CMW500	152372	Mar. 13, 2023
6	Wireless Communication Test SET	Agilent	E5515C	MY48364183	Jan. 23, 2023
7	966 Chamber Room	ETS	9*6*6	N/A	Jul. 14, 2022 Jul. 14, 2023

Radiated Emissions - 30 MHz to 1 GHz					
Item	Kind of Equipment	Manufacturer	Type No.	Serial No.	Calibrated until
1	Antenna	Schwarzbeck	VULB9160	9160-3232	Mar. 03, 2023
2	Amplifier	HP	8447D	2944A08742	Jan. 22, 2023
3	Cable	emci	LMR-400	N/A	Nov. 30, 2022
4	Controller	CT	SC100	N/A	N/A
5	Controller	MF	MF-7802	MF780208416	N/A
6	Receiver	Agilent	N9038A	MY52130039	Jan. 22, 2023
7	Measurement Software	Farad	EZ-EMC Ver.NB-03A1-01	N/A	N/A
8	wideband radio communication tester	R&S	CMW500	152372	Mar. 13, 2023
9	Wireless Communication Test SET	Agilent	E5515C	MY48364183	Jan. 23, 2023
10	966 Chamber Room	RM	9*6*6	N/A	Jul. 15, 2022 Jul. 15, 2023

Radiated Emissions - Above 1 GHz					
Item	Kind of Equipment	Manufacturer	Type No.	Serial No.	Calibrated until
1	Double Ridged Horn Antenna	ARA	DRG-118A	16554	Apr. 18, 2023
2	Broad-Band Horn Antenna	Schwarzbeck	BBHA 9170	9170319	Jun 11, 2023
3	Amplifier	Agilent	8449B	3008A02584	Jul. 03, 2023
4	Controller	CT	SC100	N/A	N/A
5	Controller	MF	MF-7802	MF780208416	N/A
6	Receiver	Agilent	N9038A	MY52130039	Jan. 22, 2023
7	EXA Spectrum Analyzer	Keysight	N9010A	MY56480488	Jan. 22, 2023
8*	Low Noise Amplifier	CONNPHY	CLN-18G40G-4330-K	619413	Jul. 05, 2025
9	Cable	Talent microwave	A81-SMAMSMAM-12.5M	N/A	Oct. 15, 2022
10	Cable	Talent microwave	A40-2.92M2.92M-2.5M	N/A	Nov. 30, 2022
11	Measurement Software	Farad	EZ-EMC Ver.NB-03A1-01	N/A	N/A
12	wideband radio communication tester	R&S	CMW500	152372	Mar. 13, 2023
13	Wireless Communication Test SET	Agilent	E5515C	MY48364183	Jan. 23, 2023
14	966 Chamber Room	RM	9*6*6	N/A	Jul. 15, 2022 Jul. 15, 2023

Conducted Measurement					
Item	Kind of Equipment	Manufacturer	Type No.	Serial No.	Calibrated until
1	8960 Series 10 Wireless Com Test set	Agilent	E5515E	MY52112163	Jul. 24, 2022 Jul. 16, 2023
2	MXA Signal Analyzer	Keysight	N9020A	MY49100060	Jul. 24, 2022 Jul. 16, 2023
3	Power Splitter	Mini-Circuits	ZFRSC-183-S+	SF103501511S	Jul. 24, 2022 Jul. 16, 2023
4	wideband radio communication tester	R&S	CMW500	104462	Jul. 24, 2022 Jul. 16, 2023
5	Const Temp. & Humidity Chamber	Bell	BTH-50C	20170306001	Feb. 19, 2023
6	Mob Comms DC Supply	Agilent	66319D	MY52002262	Feb. 20, 2023
7	Signal Analyzer	R&S	FSQ-26	200822	Feb. 19, 2023

Remark: "N/A" denotes no model name, serial no. or calibration specified.

Except * item, all calibration period of equipment list is one year.

"**" calibration period of equipment list is three year.

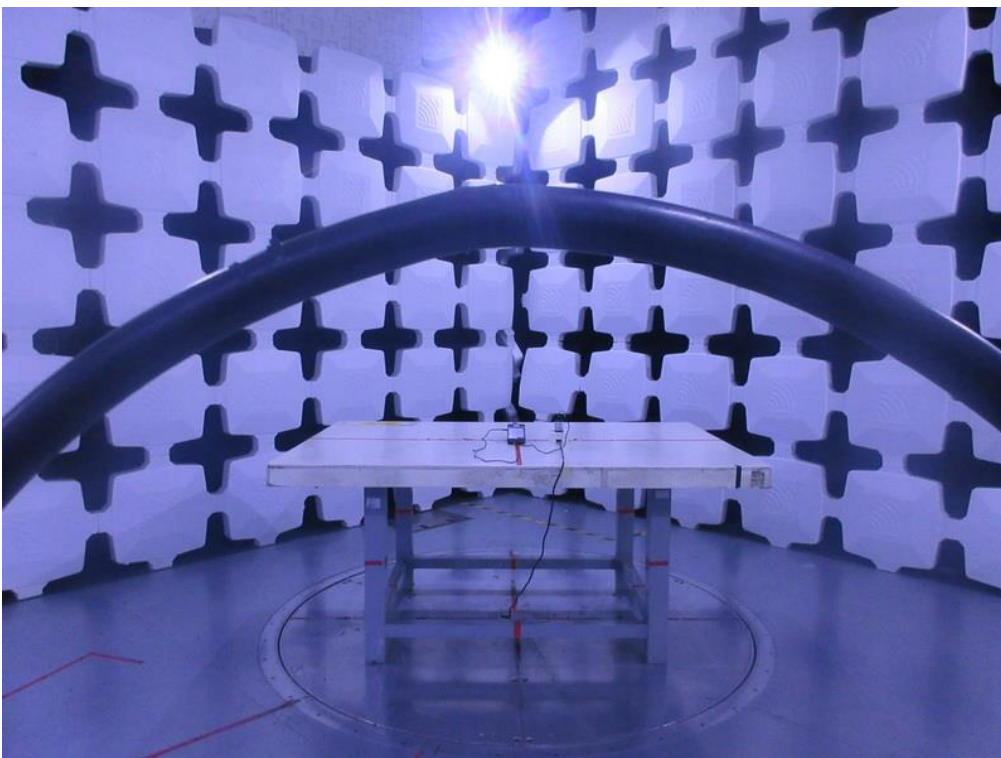
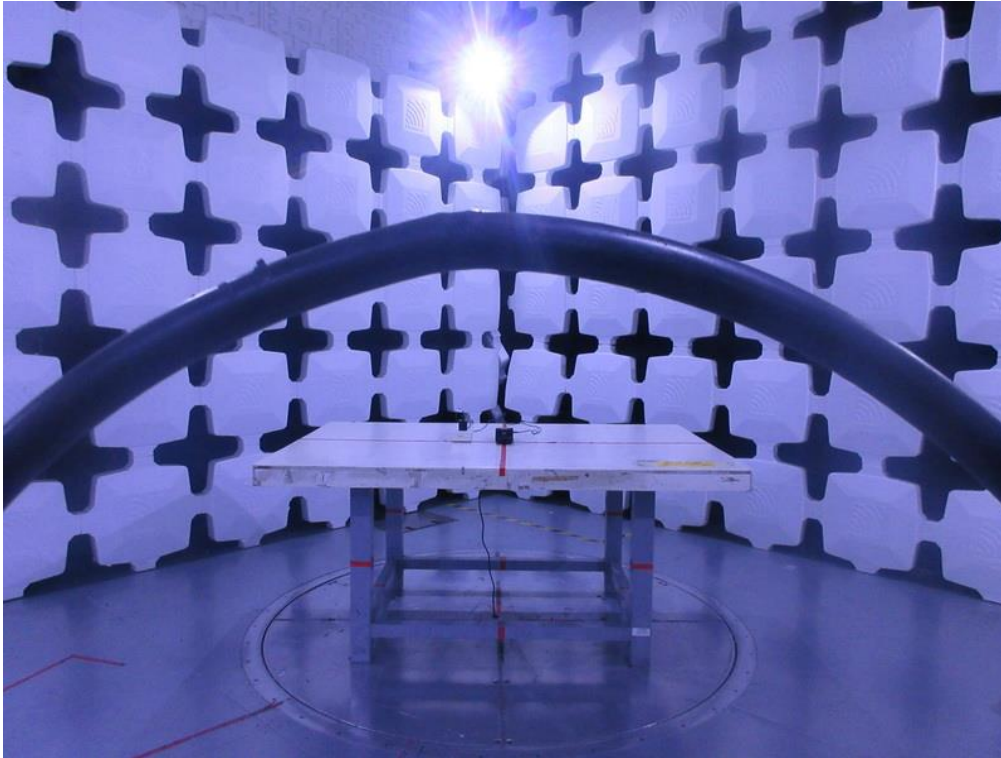
5. EUT TEST PHOTO**Radiated Emissions Test Photos****9 kHz to 30 MHz**

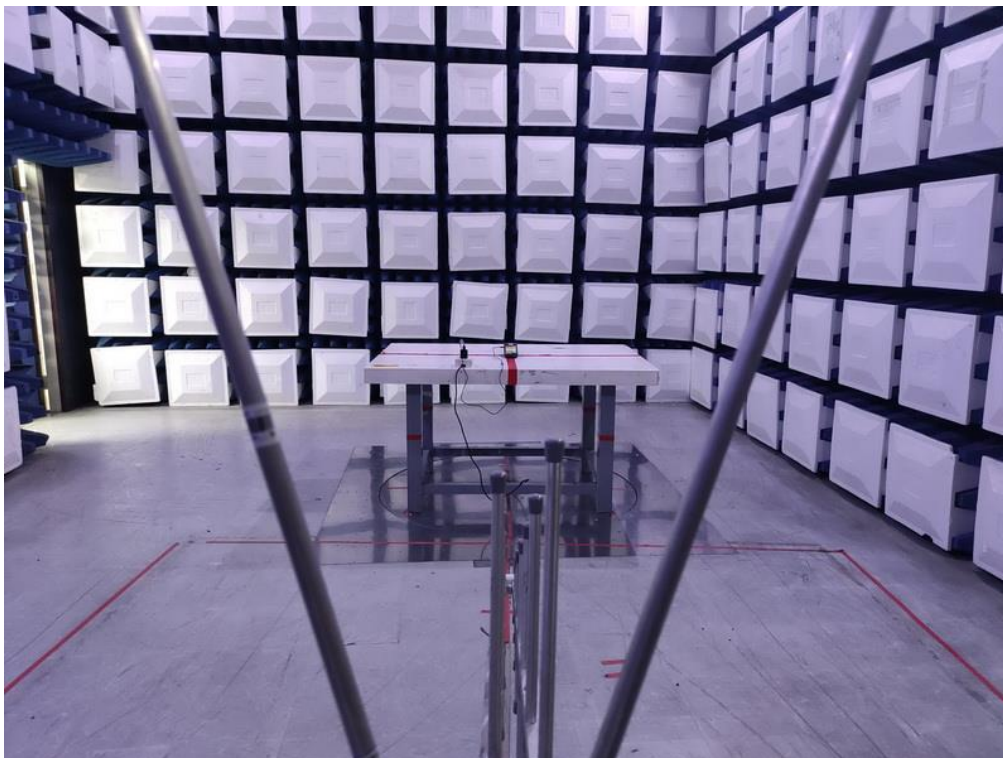
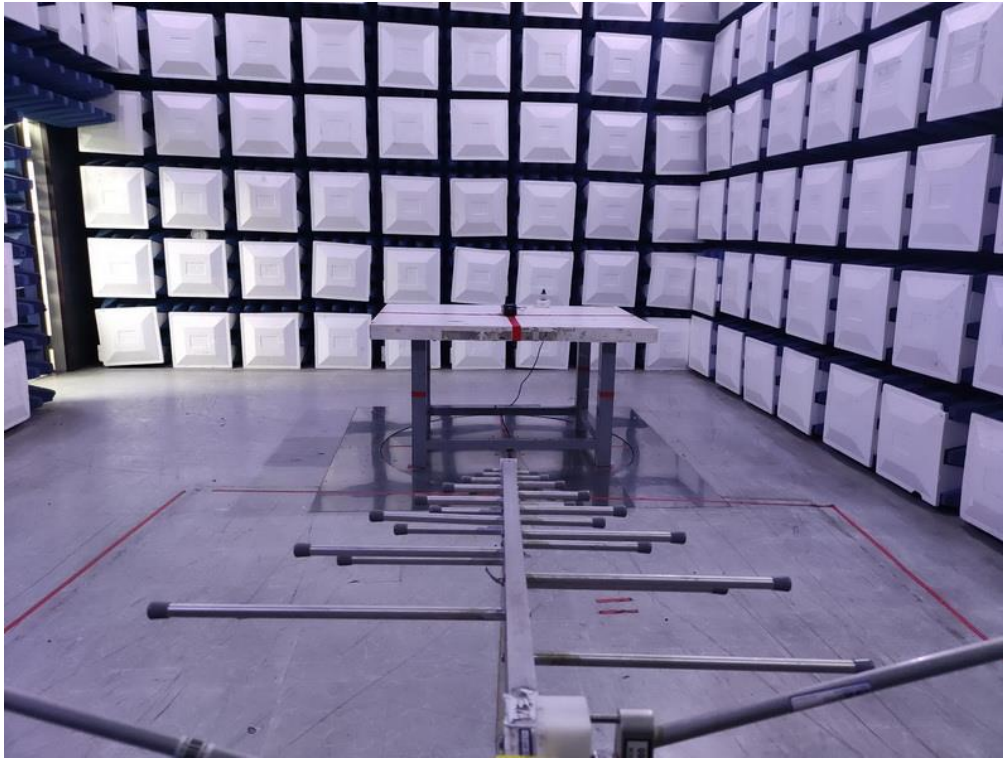
Radiated Emissions Test Photos**30 MHz to 1 GHz**

Radiated Emissions Test Photos**Above 1 GHz**

APPENDIX A - OUTPUT POWER

Output Power (dBm)

PCS1900		512CH	661CH	810CH
		1850.2MHz	1880MHz	1909.8MHz
GPRS/EDGE (GMSK)	1 Tx Slot	29.32	30.47	30.62
	2 Tx Slot	28.71	29.76	29.89
	3 Tx Slot	27.44	28.44	28.55
	4 Tx Slot	26.74	27.72	27.82
EDGE (8PSK)	1 Tx Slot	26.42	27.26	27.30
	2 Tx Slot	25.66	26.40	26.50
	3 Tx Slot	23.92	24.78	24.64
	4 Tx Slot	22.72	23.71	23.02

Modulation	Band	WCDMA Band II		
	Tx Channel	9262CH	9400CH	9538CH
	Frequency	1852.4MHz	1880MHz	1907.6MHz
QPSK	RMC 12.2K	23.26	23.25	23.33
	RMC 64K	23.25	23.24	23.37
	RMC 144K	23.26	23.25	23.37
	RMC 384K	23.25	23.25	23.36
	HSDPA Subtest-1	22.12	22	22.15
	HSDPA Subtest-2	21.78	21.94	21.56
	HSDPA Subtest-3	21.2	21.43	21.32
	HSDPA Subtest-4	21.21	21.44	21.22
	HSUPA Subtest-1	20.22	20.26	20.19
	HSUPA Subtest-2	19.98	20.03	19.87
	HSUPA Subtest-3	20.74	20.69	20.67
	HSUPA Subtest-4	20.23	20.27	20.33
	HSUPA Subtest-5	21.46	21.5	21.47

LTE Band / BW	Modulation	RB Size	RB Offset	Low CH	Mid CH	High CH
				18607CH	18900CH	19193CH
				1850.7MHz	1880MHz	1909.3MHz
2 / 1.4MHz	QPSK	1	0	24.29	24.26	23.73
		1	2	24.26	24.34	23.86
		1	5	24.29	24.23	23.75
		3	0	24.01	23.97	23.75
		3	1	24.00	23.87	23.81
		3	2	23.96	23.83	23.74
	16QAM	6	0	23.52	23.54	22.84
		1	0	22.89	22.95	23.01
		1	2	22.94	23.04	23.10
		1	5	22.92	22.95	23.01
		3	0	23.08	22.93	22.90
		3	1	23.13	22.97	22.94
	64QAM	3	2	23.06	22.95	22.91
		6	0	22.10	22.06	21.72
		1	0	22.37	22.41	21.55
		1	2	22.43	22.49	21.67
		1	5	22.33	22.25	21.53
		3	0	22.13	22.32	21.56
		3	1	22.02	22.32	21.60
		3	2	22.05	22.40	21.57
		6	0	21.11	21.17	20.71

LTE Band / BW	Modulation	RB Size	RB Offset	Low CH	Mid CH	High CH
				18615CH	18900CH	19185CH
				1851.5MHz	1880MHz	1908.5MHz
2 / 3MHz	QPSK	1	0	23.88	24.00	23.72
		1	7	24.01	24.07	23.83
		1	14	23.95	23.96	23.74
		8	0	22.98	22.99	22.81
		8	4	22.98	23.02	22.80
		8	7	22.93	22.96	22.74
		15	0	22.94	22.91	22.75
	16QAM	1	0	22.80	23.21	22.72
		1	7	22.91	23.34	22.82
		1	14	22.82	23.23	22.67
		8	0	22.00	21.97	21.78
		8	4	22.02	22.01	21.81
		8	7	21.96	21.93	21.72
		15	0	21.90	21.88	21.66
	64QAM	1	0	22.02	21.85	21.70
		1	7	22.18	22.02	21.81
		1	14	22.02	21.90	21.59
		8	0	20.79	20.79	20.44
		8	4	20.81	20.85	20.44
		8	7	20.74	20.78	20.37
		15	0	20.69	20.78	20.45

LTE Band / BW	Modulation	RB Size	RB Offset	Low CH	Mid CH	High CH
				18625CH	18900CH	19175CH
				1852.5MHz	1880MHz	1907.5MHz
2 / 5MHz	QPSK	1	0	23.88	23.85	23.66
		1	13	24.05	23.95	23.79
		1	24	23.91	23.80	23.68
		12	0	22.89	22.91	22.83
		12	6	22.93	22.94	22.79
		12	11	22.93	22.94	22.67
		25	0	22.94	22.89	22.74
	16QAM	1	0	22.96	23.29	22.69
		1	13	23.10	23.40	22.83
		1	24	22.98	23.26	22.70
		12	0	21.97	21.98	21.87
		12	6	22.00	22.05	21.80
		12	11	22.00	22.01	21.68
		25	0	21.86	21.89	21.64
	64QAM	1	0	21.60	21.95	21.62
		1	13	21.72	22.07	21.76
		1	24	21.61	21.94	21.61
		12	0	20.81	20.64	20.60
		12	6	20.82	20.71	20.54
		12	11	20.77	20.70	20.41
		25	0	20.68	20.64	20.42

LTE Band / BW	Modulation	RB Size	RB Offset	Low CH	Mid CH	High CH
				18650CH	18900CH	19150CH
				1855MHz	1880MHz	1905MHz
2 / 10MHz	QPSK	1	0	23.85	23.94	23.70
		1	25	24.13	24.14	23.88
		1	49	23.88	23.88	23.68
		25	0	23.03	22.95	22.69
		25	13	23.02	23.00	22.78
		25	25	22.96	22.93	22.51
		50	0	23.01	22.92	22.57
	16QAM	1	0	22.76	23.19	22.64
		1	25	22.98	23.37	22.84
		1	49	22.77	23.14	22.66
		25	0	21.99	21.90	21.71
		25	13	21.97	21.95	21.79
		25	25	21.90	21.90	21.51
		50	0	21.94	21.89	21.57
	64QAM	1	0	22.01	21.82	21.71
		1	25	22.19	21.98	21.78
		1	49	22.00	21.84	21.61
		25	0	20.83	20.69	20.49
		25	13	20.77	20.80	20.52
		25	25	20.71	20.72	20.30
		50	0	20.77	20.68	20.33

LTE Band / BW	Modulation	RB Size	RB Offset	Low CH	Mid CH	High CH
				18675CH	18900CH	19125CH
				1857.5MHz	1880MHz	1902.5MHz
2 / 15MHz	QPSK	1	0	23.79	23.86	23.74
		1	38	23.93	23.97	23.83
		1	74	23.79	23.77	23.66
		36	0	23.01	22.77	22.78
		36	18	23.03	23.03	22.84
		36	39	22.96	22.92	22.67
		75	0	23.06	22.94	22.69
	16QAM	1	0	22.70	23.08	22.95
		1	38	22.83	23.23	23.00
		1	74	22.68	23.06	22.88
		36	0	21.97	22.62	21.70
		36	18	21.97	22.03	21.79
		36	39	21.93	21.90	21.60
		75	0	21.95	21.90	21.64
	64QAM	1	0	21.94	21.73	22.06
		1	38	22.04	21.85	22.06
		1	74	21.91	21.67	21.88
		36	0	20.84	21.67	20.52
		36	18	20.79	20.79	20.56
		36	39	20.78	20.73	20.35
		75	0	20.80	20.70	20.45

LTE Band / BW	Modulation	RB Size	RB Offset	Low CH	Mid CH	High CH
				18700CH	18900CH	19100CH
				1860MHz	1880MHz	1900MHz
2 / 20MHz	QPSK	1	0	23.83	23.87	23.74
		1	50	24.37	24.03	23.90
		1	99	23.82	23.76	23.60
		50	0	23.22	22.97	22.77
		50	25	23.05	23.13	22.81
		50	50	22.93	22.73	22.54
		100	0	22.94	22.77	22.72
	16QAM	1	0	23.09	22.98	23.04
		1	50	23.53	23.85	23.33
		1	99	23.03	22.99	22.89
		50	0	21.98	21.71	21.75
		50	25	21.89	21.87	21.77
		50	50	21.90	21.68	21.53
		100	0	21.91	21.70	21.68
	64QAM	1	0	21.76	22.05	21.57
		1	50	22.17	21.78	21.86
		1	99	21.69	21.99	21.36
		50	0	20.81	20.59	20.52
		50	25	20.74	20.71	20.51
		50	50	20.77	20.55	20.33
		100	0	20.75	20.54	20.45

EIRP (dBm)

PCS1900		512CH	661CH	810CH
		1850.2MHz	1880MHz	1909.8MHz
GPRS/EDGE (GMSK)	1 Tx Slot	30.95	32.10	32.25
	2 Tx Slot	30.34	31.39	31.52
	3 Tx Slot	29.07	30.07	30.18
	4 Tx Slot	28.37	29.35	29.45
EDGE (8PSK)	1 Tx Slot	28.05	28.89	28.93
	2 Tx Slot	27.29	28.03	28.13
	3 Tx Slot	25.55	26.41	26.27
	4 Tx Slot	24.35	25.34	24.65

Modulation	Band	WCDMA Band II		
	Tx Channel	9262CH	9400CH	9538CH
	Frequency	1852.4MHz	1880MHz	1907.6MHz
QPSK	RMC 12.2K	24.89	24.88	24.96
	RMC 64K	24.88	24.87	25.00
	RMC 144K	24.89	24.88	25.00
	RMC 384K	24.88	24.88	24.99
	HSDPA Subtest-1	23.75	23.63	23.78
	HSDPA Subtest-2	23.41	23.57	23.19
	HSDPA Subtest-3	22.83	23.06	22.95
	HSDPA Subtest-4	22.84	23.07	22.85
	HSUPA Subtest-1	21.85	21.89	21.82
	HSUPA Subtest-2	21.61	21.66	21.50
	HSUPA Subtest-3	22.37	22.32	22.30
	HSUPA Subtest-4	21.86	21.90	21.96
	HSUPA Subtest-5	23.09	23.13	23.10

LTE Band / BW	Modulation	RB Size	RB Offset	Low CH	Mid CH	High CH
				18607CH	18900CH	19193CH
				1850.7MHz	1880MHz	1909.3MHz
2 / 1.4MHz	QPSK	1	0	25.92	25.89	25.36
		1	2	25.89	25.97	25.49
		1	5	25.92	25.86	25.38
		3	0	25.64	25.60	25.38
		3	1	25.63	25.50	25.44
		3	2	25.59	25.46	25.37
	16QAM	6	0	25.15	25.17	24.47
		1	0	24.52	24.58	24.64
		1	2	24.57	24.67	24.73
		1	5	24.55	24.58	24.64
		3	0	24.71	24.56	24.53
		3	1	24.76	24.60	24.57
	64QAM	3	2	24.69	24.58	24.54
		6	0	23.73	23.69	23.35
		1	0	24.00	24.04	23.18
		1	2	24.06	24.12	23.30
		1	5	23.96	23.88	23.16
		3	0	23.76	23.95	23.19
		3	1	23.65	23.95	23.23
		3	2	23.68	24.03	23.20
		6	0	22.74	22.80	22.34

LTE Band / BW	Modulation	RB Size	RB Offset	Low CH	Mid CH	High CH
				18615CH	18900CH	19185CH
				1851.5MHz	1880MHz	1908.5MHz
2 / 3MHz	QPSK	1	0	25.51	25.63	25.35
		1	7	25.64	25.70	25.46
		1	14	25.58	25.59	25.37
		8	0	24.61	24.62	24.44
		8	4	24.61	24.65	24.43
		8	7	24.56	24.59	24.37
		15	0	24.57	24.54	24.38
	16QAM	1	0	24.43	24.84	24.35
		1	7	24.54	24.97	24.45
		1	14	24.45	24.86	24.30
		8	0	23.63	23.60	23.41
		8	4	23.65	23.64	23.44
		8	7	23.59	23.56	23.35
		15	0	23.53	23.51	23.29
	64QAM	1	0	23.65	23.48	23.33
		1	7	23.81	23.65	23.44
		1	14	23.65	23.53	23.22
		8	0	22.42	22.42	22.07
		8	4	22.44	22.48	22.07
		8	7	22.37	22.41	22.00
		15	0	22.32	22.41	22.08

LTE Band / BW	Modulation	RB Size	RB Offset	Low CH	Mid CH	High CH
				18625CH	18900CH	19175CH
				1852.5MHz	1880MHz	1907.5MHz
2 / 5MHz	QPSK	1	0	25.51	25.48	25.29
		1	13	25.68	25.58	25.42
		1	24	25.54	25.43	25.31
		12	0	24.52	24.54	24.46
		12	6	24.56	24.57	24.42
		12	11	24.56	24.57	24.30
		25	0	24.57	24.52	24.37
	16QAM	1	0	24.59	24.92	24.32
		1	13	24.73	25.03	24.46
		1	24	24.61	24.89	24.33
		12	0	23.60	23.61	23.50
		12	6	23.63	23.68	23.43
		12	11	23.63	23.64	23.31
		25	0	23.49	23.52	23.27
	64QAM	1	0	23.23	23.58	23.25
		1	13	23.35	23.70	23.39
		1	24	23.24	23.57	23.24
		12	0	22.44	22.27	22.23
		12	6	22.45	22.34	22.17
		12	11	22.40	22.33	22.04
		25	0	22.31	22.27	22.05

LTE Band / BW	Modulation	RB Size	RB Offset	Low CH	Mid CH	High CH
				18650CH	18900CH	19150CH
				1855MHz	1880MHz	1905MHz
2 / 10MHz	QPSK	1	0	25.48	25.57	25.33
		1	25	25.76	25.77	25.51
		1	49	25.51	25.51	25.31
		25	0	24.66	24.58	24.32
		25	13	24.65	24.63	24.41
		25	25	24.59	24.56	24.14
		50	0	24.64	24.55	24.20
	16QAM	1	0	24.39	24.82	24.27
		1	25	24.61	25.00	24.47
		1	49	24.40	24.77	24.29
		25	0	23.62	23.53	23.34
		25	13	23.60	23.58	23.42
		25	25	23.53	23.53	23.14
		50	0	23.57	23.52	23.20
	64QAM	1	0	23.64	23.45	23.34
		1	25	23.82	23.61	23.41
		1	49	23.63	23.47	23.24
		25	0	22.46	22.32	22.12
		25	13	22.40	22.43	22.15
		25	25	22.34	22.35	21.93
		50	0	22.40	22.31	21.96

LTE Band / BW	Modulation	RB Size	RB Offset	Low CH	Mid CH	High CH
				18675CH	18900CH	19125CH
				1857.5MHz	1880MHz	1902.5MHz
2 / 15MHz	QPSK	1	0	25.42	25.49	25.37
		1	38	25.56	25.60	25.46
		1	74	25.42	25.40	25.29
		36	0	24.64	24.40	24.41
		36	18	24.66	24.66	24.47
		36	39	24.59	24.55	24.30
		75	0	24.69	24.57	24.32
	16QAM	1	0	24.33	24.71	24.58
		1	38	24.46	24.86	24.63
		1	74	24.31	24.69	24.51
		36	0	23.60	24.25	23.33
		36	18	23.60	23.66	23.42
		36	39	23.56	23.53	23.23
		75	0	23.58	23.53	23.27
	64QAM	1	0	23.57	23.36	23.69
		1	38	23.67	23.48	23.69
		1	74	23.54	23.30	23.51
		36	0	22.47	23.30	22.15
		36	18	22.42	22.42	22.19
		36	39	22.41	22.36	21.98
		75	0	22.43	22.33	22.08

LTE Band / BW	Modulation	RB Size	RB Offset	Low CH	Mid CH	High CH
				18700CH	18900CH	19100CH
				1860MHz	1880MHz	1900MHz
2 / 20MHz	QPSK	1	0	25.46	25.50	25.37
		1	50	26.00	25.66	25.53
		1	99	25.45	25.39	25.23
		50	0	24.85	24.60	24.40
		50	25	24.68	24.76	24.44
		50	50	24.56	24.36	24.17
		100	0	24.57	24.40	24.35
	16QAM	1	0	24.72	24.61	24.67
		1	50	25.16	25.48	24.96
		1	99	24.66	24.62	24.52
		50	0	23.61	23.34	23.38
		50	25	23.52	23.50	23.40
		50	50	23.53	23.31	23.16
		100	0	23.54	23.33	23.31
	64QAM	1	0	23.39	23.68	23.20
		1	50	23.80	23.41	23.49
		1	99	23.32	23.62	22.99
		50	0	22.44	22.22	22.15
		50	25	22.37	22.34	22.14
		50	50	22.40	22.18	21.96
		100	0	22.38	22.17	22.08

APPENDIX B - OCCUPIED BANDWIDTH

PCS1900_GPRS			
Channel	Frequency (MHz)	99% Occupied Bandwidth (MHz)	26dB Bandwidth (MHz)
		QPSK	QPSK
512	1850.2	0.2430	0.3181
661	1880	0.2436	0.3118
810	1909.8	0.2435	0.3226

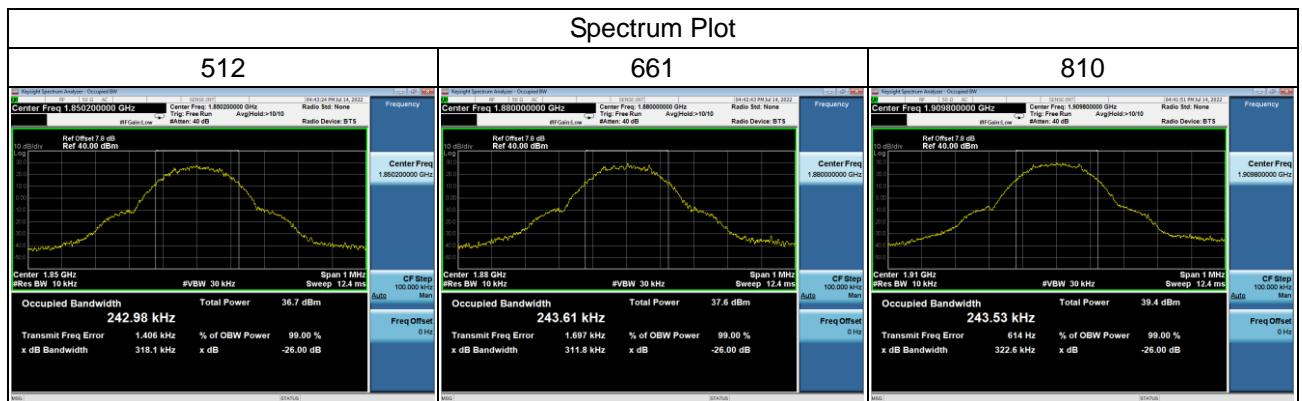

PCS1900_EDGE			
Channel	Frequency (MHz)	99% Occupied Bandwidth (MHz)	26dB Bandwidth (MHz)
		QPSK	QPSK
512	1850.2	0.2563	0.3373
661	1880	0.2606	0.3353
810	1909.8	0.2637	0.3431

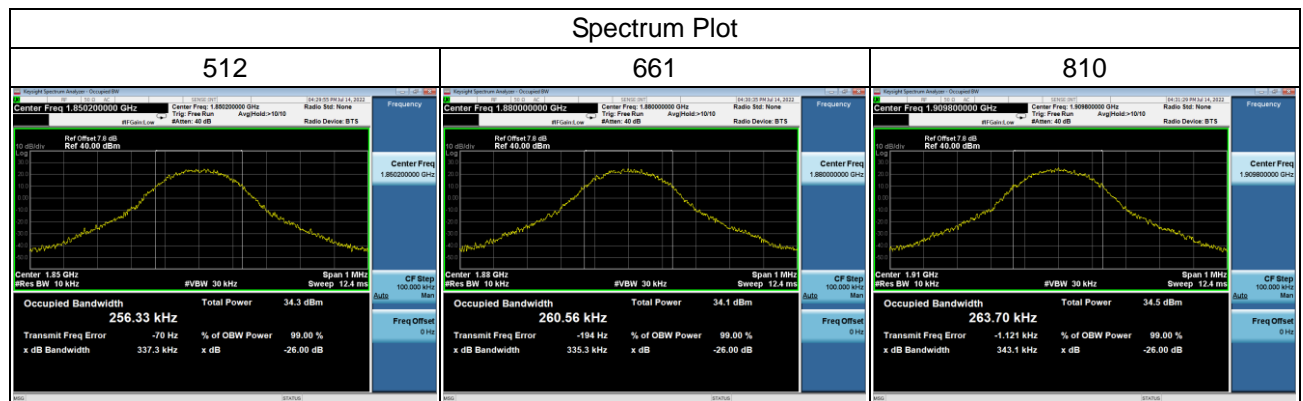

WCDMA Band II_WCDMA			
Channel	Frequency (MHz)	99% Occupied Bandwidth (MHz)	26dB Bandwidth (MHz)
		QPSK	QPSK
9262	1852.4	4.1678	4.717
9400	1880	4.1650	4.708
9538	1907.6	4.1588	4.707

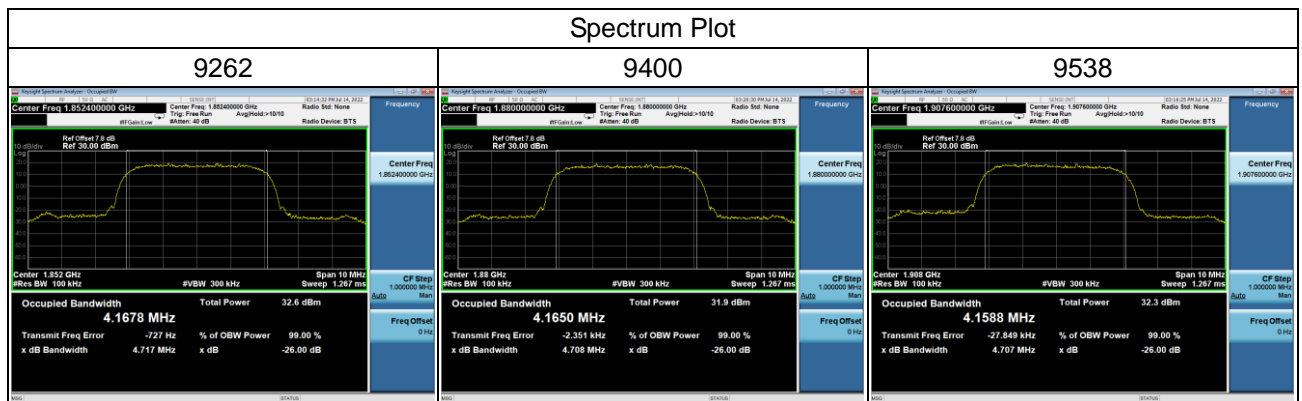

LTE Band 2_1.4MHz							
Channel	Frequency (MHz)	99% Occupied Bandwidth (MHz)			26dB Bandwidth (MHz)		
		QPSK	16QAM	64QAM	QPSK	16QAM	64QAM
18607	1850.7	1.0985	1.0902	1.0905	1.285	1.283	1.295
18900	1880	1.0952	1.0854	1.0863	1.272	1.275	1.285
19193	1909.3	1.0843	1.0937	1.0959	1.275	1.286	1.294

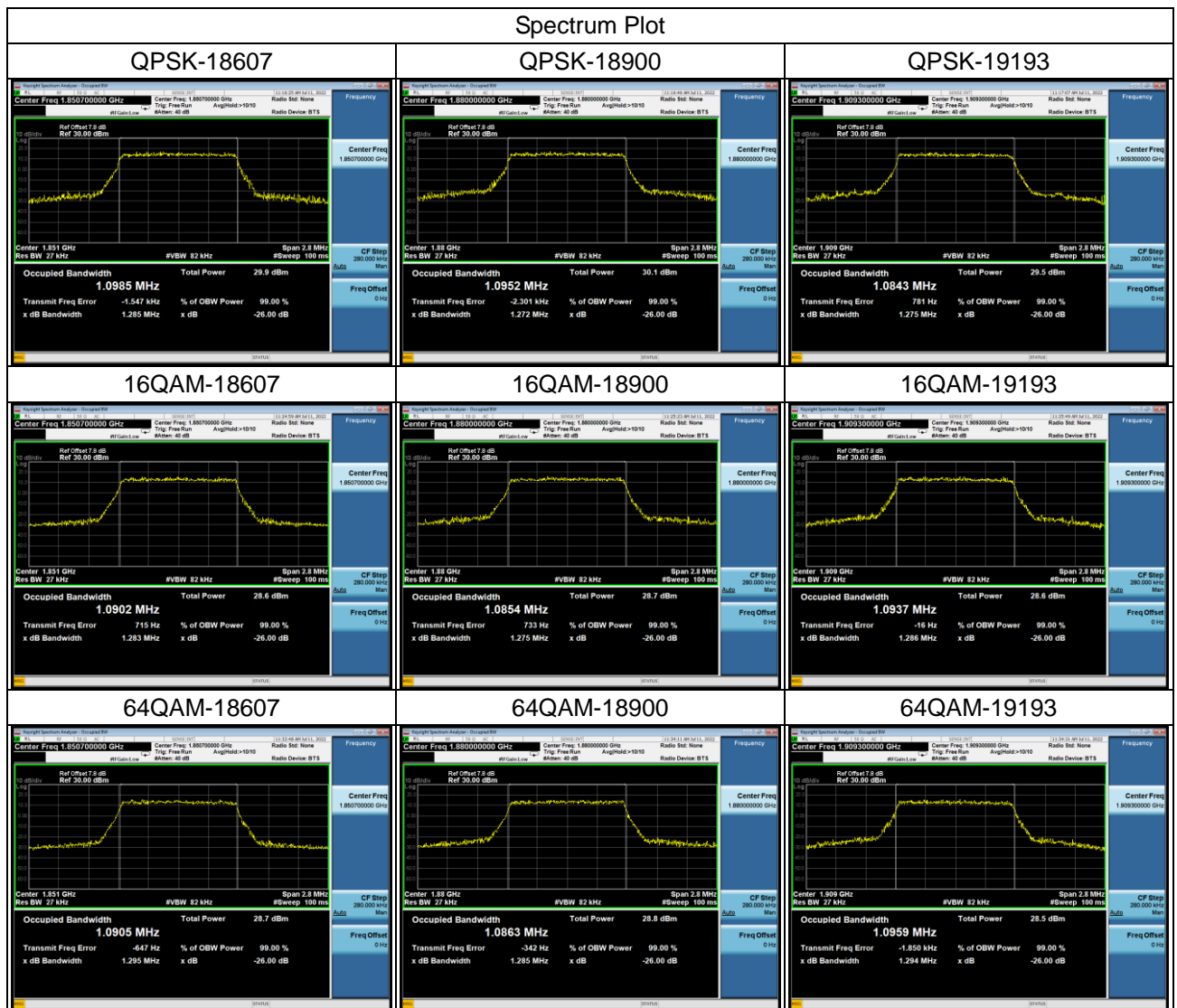

LTE Band 2_3MHz							
Channel	Frequency (MHz)	99% Occupied Bandwidth (MHz)			26dB Bandwidth (MHz)		
		QPSK	16QAM	64QAM	QPSK	16QAM	64QAM
18615	1851.5	2.6870	2.6878	2.6907	3.383	2.915	2.894
18900	1880	2.6893	2.6825	2.6816	2.896	2.917	2.919
19185	1908.5	2.6917	2.6810	2.6836	2.905	2.902	2.904

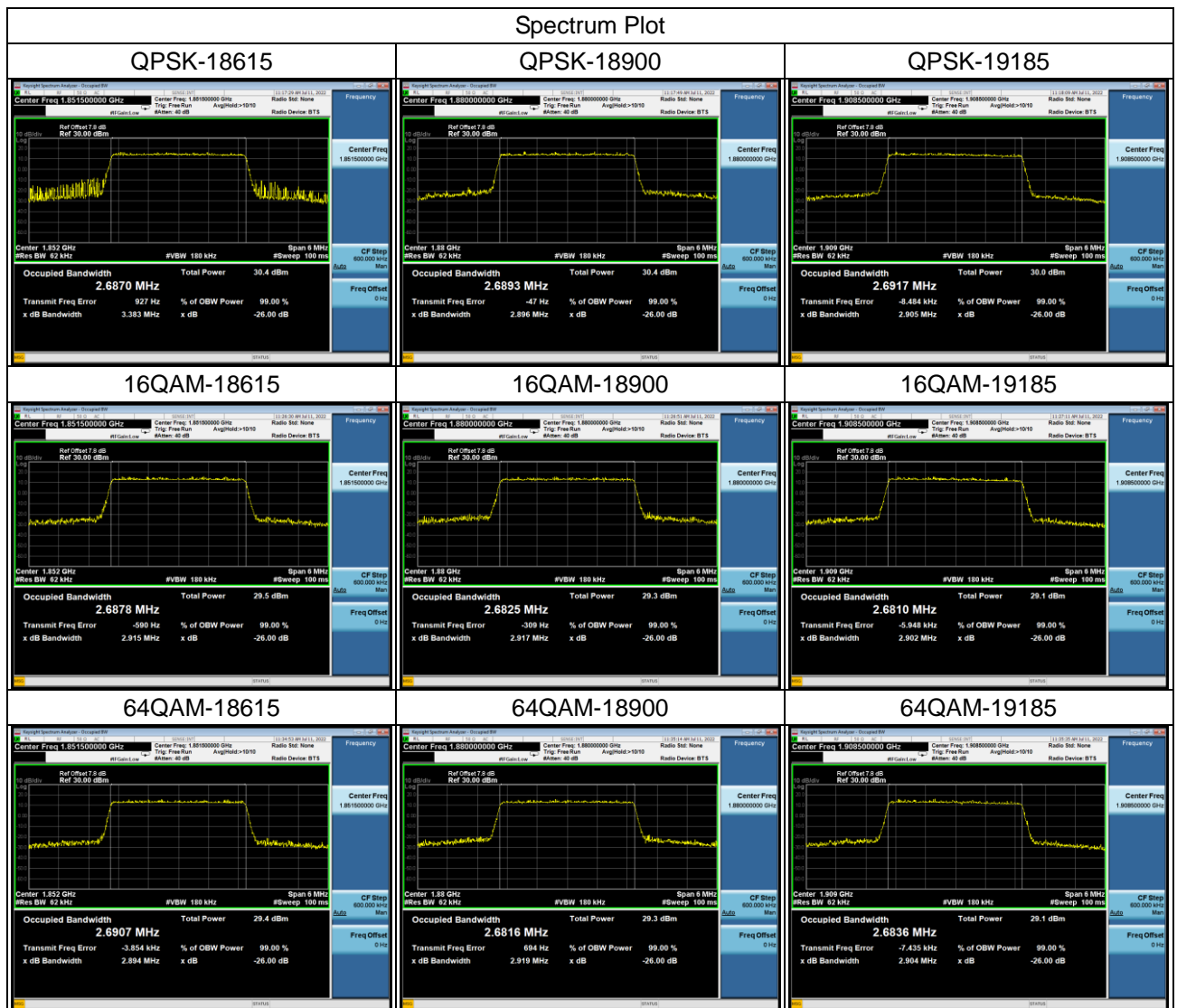

LTE Band 2_5MHz							
Channel	Frequency (MHz)	99% Occupied Bandwidth (MHz)			26dB Bandwidth (MHz)		
		QPSK	16QAM	64QAM	QPSK	16QAM	64QAM
18625	1852.5	4.5332	4.5132	4.5092	5.246	5.199	5.184
18900	1880	4.5076	4.5131	4.5095	5.115	5.136	5.096
19175	1907.5	4.5154	4.5042	4.5112	5.079	5.227	5.135

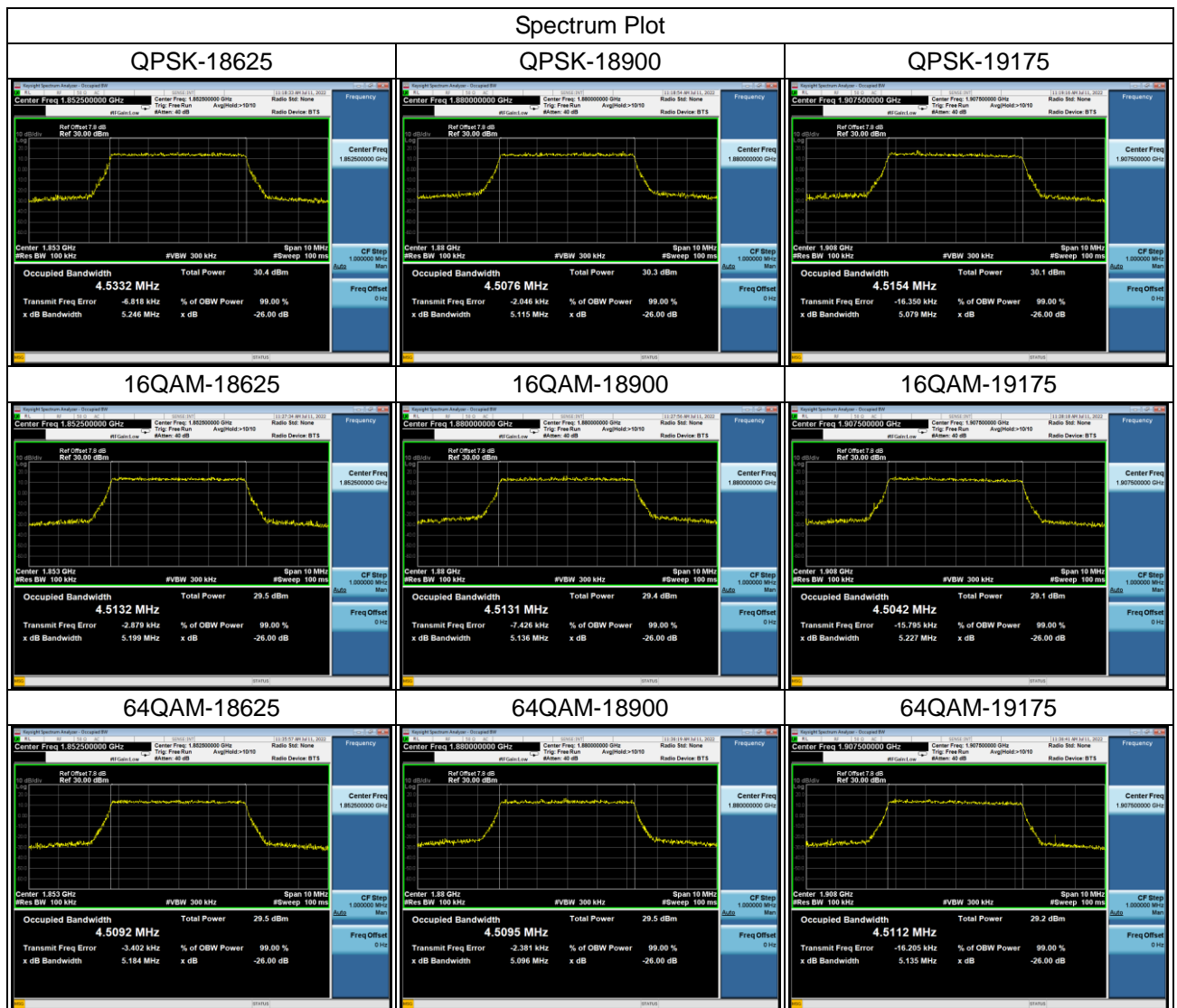

LTE Band 2_10MHz							
Channel	Frequency (MHz)	99% Occupied Bandwidth (MHz)			26dB Bandwidth (MHz)		
		QPSK	16QAM	64QAM	QPSK	16QAM	64QAM
18650	1855	9.0059	8.9875	8.9943	10.24	10.07	10.02
18900	1880	8.9833	8.9827	9.0016	10.10	10.11	10.12
19150	1905	8.9668	8.9483	8.9657	9.949	9.957	10.06

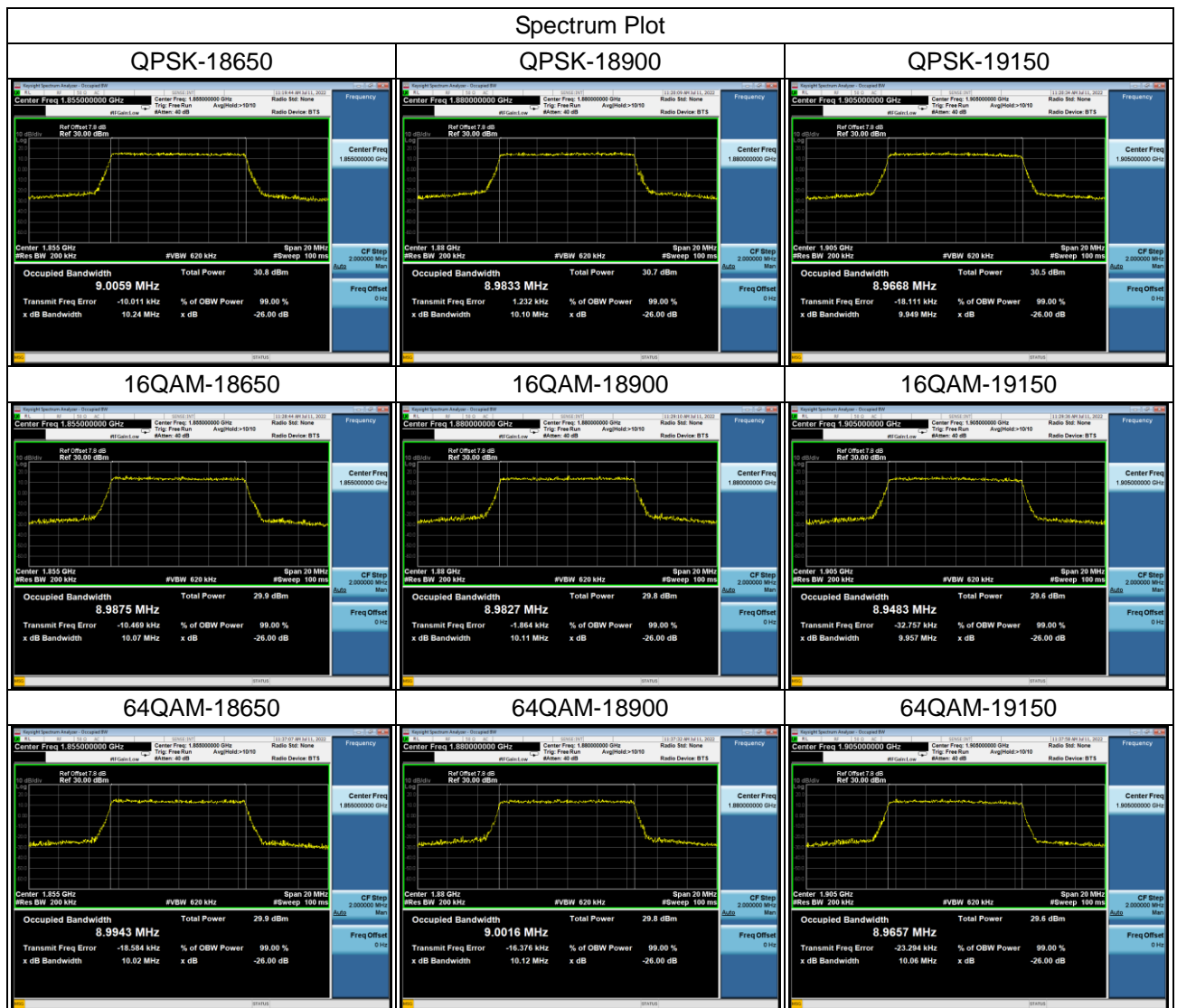

LTE Band 2_15MHz							
Channel	Frequency (MHz)	99% Occupied Bandwidth (MHz)			26dB Bandwidth (MHz)		
		QPSK	16QAM	64QAM	QPSK	16QAM	64QAM
18675	1857.5	13.503	13.514	13.513	15.13	15.05	15.08
18900	1880	13.443	13.455	13.448	15.00	15.03	14.97
19125	1902.5	13.421	13.433	13.422	14.85	14.87	14.87

Spectrum Plot

