



FCC Radio Test Report

FCC ID: XDQG25-01

This report concerns: Original Grant

Project No. : 2403G125
Equipment : POS Terminal
Brand Name : NEXGO
Test Model : G25
Series Model : N/A
Applicant : Shenzhen Xinguodu Technology Co., Ltd.
Address : 17B JinSong Mansion, Terra Industrial & Trade Park Chegongmiao, Futian District, Shenzhen, China
Manufacturer : Shenzhen Xinguodu Technology Co., Ltd.
Address : 17B JinSong Mansion, Terra Industrial & Trade Park Chegongmiao, Futian District, Shenzhen, China
Factory : Shenzhen Xinguodu Technology Co., Ltd. Manufacture Branch
Address : Building C, Dagang Industrial Park, Changzhen Community, Gongming Office, Guangming New District, Shenzhen, Guangdong, China.
Date of Receipt : Mar. 25, 2024
Date of Test : Mar. 25, 2024 ~ Apr. 05, 2024
Issued Date : Apr. 24, 2024
Report Version : R01
Test Sample : Engineering Sample No.: SSL2024032562 for radiated, SSL2024032565 for conducted.
Standard(s) : 47 CFR FCC Part 22 Subpart H
47 CFR FCC Part 2

The above equipment has been tested and found compliance with the requirement of the relative standards by BTL Inc.

Prepared by :

Abel Cao

Abel Cao

Approved by :

Steven Lu

Steven Lu

Room 108, Building 2, No.1, Yile Road, Songshan Lake Zone, Dongguan City, Guangdong, People's Republic of China.

Tel: +86-769-8318-3000 Web: www.newbtl.com Service mail: btl_qa@newbtl.com

Declaration

BTL represents to the client that testing is done in accordance with standard procedures as applicable and that test instruments used has been calibrated with standards traceable to international standard(s) and/or national standard(s).

BTL's reports apply only to the specific samples tested under conditions. It is manufacture's responsibility to ensure that additional production units of this model are manufactured with the identical electrical and mechanical components. **BTL** assumes no responsibility for the data provided by the customer, any statements, inferences or generalizations drawn by the customer or others from the reports issued by **BTL**.

The report must not be used by the client to claim product certification, approval, or endorsement by A2LA or any agency of the U.S. Government.

This report is the confidential property of the client. As a mutual protection to the clients, the public and ourselves, the test report shall not be reproduced, except in full, without our written approval.

BTL's laboratory quality assurance procedures are in compliance with the ISO/IEC 17025: 2017 requirements, and accredited by the conformity assessment authorities listed in this test report.

BTL is not responsible for the sampling stage, so the results only apply to the sample as received.

The information, data and test plan are provided by manufacturer which may affect the validity of results, so it is manufacturer's responsibility to ensure that the apparatus meets the essential requirements of applied standards and in all the possible configurations as representative of its intended use.

Limitation

For the use of the authority's logo is limited unless the Test Standard(s)/Scope(s)/Item(s) mentioned in this test report is (are) included in the conformity assessment authorities acceptance respective.

Please note that the measurement uncertainty is provided for informational purpose only and are not use in determining the Pass/Fail results.

Table of Contents	Page
REPORT ISSUED HISTORY	5
1 . APPLICABLE STANDARDS	6
2 . SUMMARY OF TEST RESULTS	6
2.1 TEST FACILITY	7
2.2 MEASUREMENT UNCERTAINTY	7
2.3 TEST ENVIRONMENT CONDITIONS	8
3 . GENERAL INFORMATION	9
3.1 GENERAL DESCRIPTION OF EUT	9
3.2 DESCRIPTION OF TEST MODES	11
3.3 BLOCK DIGRAM SHOWING THE CONFIGURATIONOFSYSTEMTESTED	13
2.4 DESCRIPTION OF SUPPORT UNITS	13
4 . TEST RESULT	14
4.1 OUTPUT POWER MEASUREMENT	14
4.1.1 LIMIT	14
4.1.2 TEST PROCEDURE	14
4.1.3 TEST SETUP LAYOUT	14
4.1.4 TEST DEVIATION	14
4.1.5 TEST RESULTS	14
4.2 OCCUPIED BANDWIDTH MEASUREMENT	15
4.2.1 TEST PROCEDURE	15
4.2.2 TEST SETUP LAYOUT	15
4.2.3 TEST DEVIATION	15
4.2.4 TEST RESULTS	15
4.3 CONDUCTED SPURIOUS EMISSIONS MEASUREMENT	16
4.3.1 LIMIT	16
4.3.2 TEST PROCEDURES	16
4.3.3 TEST SETUP LAYOUT	16
4.3.4 TEST DEVIATION	16
4.3.5 TEST RESULTS	16
4.4 RADIATED SPURIOUS EMISSIONS MEASUREMENT	17
4.4.1 LIMIT	17
4.4.2 TEST PROCEDURES	17
4.4.3 TEST SETUP LAYOUT	18
4.4.4 TEST DEVIATION	19
4.4.5 TEST RESULTS (9KHZ TO 30MHZ)	19
4.4.6 TEST RESULTS (30MHZ TO 1000MHZ)	19
4.4.7 TEST RESULTS (ABOVE 1000MHZ)	19
4.5 BAND EDGE MEASUREMENT	20

Table of Contents	Page
4.5.1 LIMIT	20
4.5.2 TEST PROCEDURES	20
4.5.3 TEST SETUP LAYOUT	20
4.5.4 TEST DEVIATION	20
4.5.5 TEST RESULTS	20
4.6 PEAK TO AVERAGE RATIO MEASUREMENT	21
4.6.1 LIMIT	21
4.6.2 TEST PROCEDURES	21
4.6.3 TEST SETUP LAYOUT	21
4.6.4 TEST DEVIATION	21
4.6.5 TEST RESULTS	21
4.7 FREQUENCY STABILITY MEASUREMENT	22
4.7.1 LIMIT	22
4.7.2 TEST PROCEDURES	22
4.7.3 TEST SETUP LAYOUT	22
4.7.4 TEST DEVIATION	22
4.7.5 TEST RESULTS	22
4. LIST OF MEASUREMENT EQUIPMENTS	23
APPENDIX A - OUTPUT POWER	25
APPENDIX B - OCCUPIED BANDWIDTH	32
APPENDIX C - CONDUCTED SPURIOUS EMISSIONS	39
APPENDIX D - RADIATED SPURIOUS EMISSIONS (9KHZ TO 30MHZ)	43
APPENDIX E - RADIATED SPURIOUS EMISSIONS (30MHZ TO 1000MHZ)	45
APPENDIX F - RADIATED SPURIOUS EMISSIONS (ABOVE 1000MHZ)	49
APPENDIX G - BAND EDGE	53
APPENDIX H - PEAK TO AVERAGE RATIO	60
APPENDIX I - FREQUENCY STABILITY	67

REPORT ISSUED HISTORY

Report No.	Version	Description	Issued Date	Note
BTL-FCCP-1-2403G125	R00	Original Report.	Apr. 19, 2024	Invalid
BTL-FCCP-1-2403G125	R01	Removed the EUT test photo.	Apr. 24, 2024	Valid

1. APPLICABLE STANDARDS

According to the specifications of the manufacturer, the EUT must comply with the requirements of the following standards:

ANSI C63.26-2015

The following reference test guidance is not within the scope of accreditation of A2LA:

FCC KDB 971168 D01 Power Meas License Digital Systems v03r01

2. SUMMARY OF TEST RESULTS

Test procedures according to the technical standard(s):

FCC Part 22 Subpart H & Part 2			
Standard(s) Section	Test Item	Judgment	Remark
2.1046	Output Power	PASS	-----
22.913(a)(5)	Effective Radiated Power	PASS	-----
2.1049	Occupied Bandwidth	PASS	-----
2.1051 22.917(a)	Conducted Spurious Emissions	PASS	-----
2.1053 22.917(a)	Radiated Spurious Emissions	PASS	-----
22.917(a)	Band Edge Measurements	PASS	-----
22.913(d)	Peak To Average Ratio	PASS	-----
2.1055 22.355	Frequency Stability	PASS	-----

Note:

(1) "N/A" denotes test is not applicable in this test report.

2.1 TEST FACILITY

For Radiated 9kHz-30MHz items:

The test facilities used to collect the test data in this report is at the location of No.3, Jinshagang 1st Road, Dalang, Dongguan City, Guangdong People's Republic of China.

For other items:

The test facilities used to collect the test data in this report is at the location of Room 108, Building 2, No.1, Yile Road, Songshan Lake Zone, Dongguan City, Guangdong, People's Republic of China.

BTL's Registration Number for FCC: 747969

BTL's Designation Number for FCC: CN1377

2.2 MEASUREMENT UNCERTAINTY

ISO/IEC 17025 requires that an estimate of the measurement uncertainties associated with the emissions test results be included in the report. The measurement uncertainties given below are based on a 95% confidence level (based on a coverage factor (k=2))

The BTL measurement uncertainty as below table:

A. Radiated Measurement:

Test Site	Method	Measurement Frequency Range	U,(dB)
DG-CB01	CISPR	9kHz ~ 30MHz	2.36

Test Site	Method	Measurement Frequency Range	Ant. H / V	U,(dB)
SSL-CB01	CISPR	30MHz ~ 200MHz	V	4.70
		30MHz ~ 200MHz	H	3.56
		200MHz ~ 1,000MHz	V	4.92
		200MHz ~ 1,000MHz	H	4.54
		1GHz ~ 6GHz	-	4.56
		6GHz ~ 18GHz	-	5.14
		18GHz ~ 26.5GHz	-	3.30

B. Other Measurement:

Parameter	Uncertainty
Spectrum Bandwidth	±3.8 %
Maximum Output Power	±0.95 dB
Frequency Stability	±0.16 dB
Temperature	±0.08 °C
Time	±0.58 %
Supply voltages	±0.3 %

Note: Unless specifically mentioned, the uncertainty of measurement has not been taken into account to declare the compliance or non-compliance to the specification.

2.3 TEST ENVIRONMENT CONDITIONS

Test Item	Temperature	Humidity	Test Voltage	Tested By	Test Date
Output Power & ERP	22°C	52%	DC 3.6V	Gavin Ge	Mar. 25, 2024 - Apr. 02, 2024
Occupied Bandwidth	22°C	52%	DC 3.6V	Gavin Ge	Mar. 25, 2024 - Apr. 02, 2024
Conducted Spurious Emissions	22°C	52%	DC 3.6V	Gavin Ge	Mar. 25, 2024 - Apr. 02, 2024
Radiated Spurious Emissions (9 kHz to 30 MHz)	24°C	54%	AC 120V/60Hz	Hayden Chen	Apr. 03, 2024
Radiated Spurious Emissions (30 MHz to 1000 MHz)	23°C	50-55%	AC 120V/60Hz	Max Wang	Apr. 03, 2024
Radiated Spurious Emissions (Above 1000 MHz)	23°C	46-50%	AC 120V/60Hz	Max Wang	Mar. 31, 2024 - Apr. 03, 2024
Band Edge	22°C	52%	DC 3.6V	Gavin Ge	Mar. 25, 2024 - Apr. 02, 2024
Peak to Average Ratio	22°C	52%	DC 3.6V	Gavin Ge	Mar. 25, 2024 - Apr. 02, 2024
Frequency Stability	Normal & Extreme	52%	Normal & Extreme	Gavin Ge	Mar. 25, 2024 - Apr. 02, 2024

3. GENERAL INFORMATION

3.1 GENERAL DESCRIPTION OF EUT

Equipment	POS Terminal					
Brand Name	NEXGO					
Test Model	G25					
Series Model	N/A					
Model Difference(s)	N/A					
Hardware Version	V1.0					
Software Version	BF.00.16_231228					
Power Source	1) DC Voltage supplied from AC adapter. 1# Brand / Model: RUIJING / RJ49-W050100US (US plug) 2# Brand / Model: RUIJING / RJ49-W050100EU (EU plug) 3# Brand / Model: HONOR / ADS-6MA-06 05050EPG (EU plug) 4# Brand / Model: HONOR / ADS-6MA-06 05050EPCU (US plug) 2) Supplied from battery. Model: G2-18650					
Power Rating	1) 1# I/P: 100-240V~ 50/60Hz 250mA O/P: 5.0V --- 1000mA 2# I/P: 100-240V~ 50/60Hz 250mA O/P: 5.0V --- 1.0A 5.0W 3# I/P: 100-240V~ 50/60Hz Max. 0.3A O/P: 5.0V --- 1.0A 5.0W 4# I/P: 100-240V~ 50/60Hz Max. 0.3A O/P: 5V --- 1.0A 2) DC 3.6V, 2600mAh, 9.36Wh					
IMEI No.	Radiated	866496070492148				
	Conducted	865235057366193				
Modulation Type	GPRS	GMSK				
	EDGE	GMSK, 8PSK				
	WCDMA/HSDPA/HSUPA	UL: QPSK, 16QAM DL: QPSK, 16QAM, 64QAM				
	LTE	UL: QPSK, 16QAM DL: QPSK, 16QAM, 64QAM				
Max. ERP	GPRS 850	GMSK	30.25	dBm		
	EDGE 850	8PSK	25.26	dBm		
	WCDMA Band V	QPSK	19.83	dBm		
	HSDPA Band V	QPSK	19.60	dBm		
	HSUPA Band V	QPSK	19.64	dBm		
	LTE	Channel Bandwidth (MHz)	QPSK (dBm)	16QAM (dBm)	64QAM (dBm)	
			1.4	20.04	19.26	19.04
	Band 5		3	19.78	19.09	19.34
			5	19.92	19.24	19.07
			10	19.76	19.00	19.38

Note:

- For a more detailed features description, please refer to the manufacturer's specifications or the user's manual.
- There are two kinds of configuration products: RF is the same and NFC/WIFI/2G/3G/4G has only one module or module.
 Configuration 1: LTE(Latin America)+WIFI + non-connection + professional scanning head + ESIM (ESMI-ESMI is the SIM card of the patch, the POS machine is a dual card, one of the card slots is affixed with ESIM, the other card slots is reserved for the ordinary SIM card) + single SIM.
 Configuration 2: LTE(Latin America)+WIFI + non-connect (contactless IC card) + fingerprint + dual SIM.

3. Channel List:

GSM 850				
Test Frequency ID	UARFCN	Frequency of Uplink (MHz)	UARFCN	Frequency of Downlink (MHz)
Low Range	128	824.2	137	869.2
Mid Range	190	836.6	199	881.6
High Range	251	848.8	260	893.8

WCDMA Band V				
Test Frequency ID	UARFCN	Frequency of Uplink (MHz)	UARFCN	Frequency of Downlink (MHz)
Low Range	4132	826.4	4357	871.4
Mid Range	4182	836.4	4407	881.4
High Range	4233	846.6	4458	891.6

LTE Band 5					
Test Frequency ID	Bandwidth (MHz)	N _{UL}	Frequency of Uplink (MHz)	N _{DL}	Frequency of Downlink (MHz)
Low Range	1.4	20407	824.7	2407	869.7
	3	20415	825.5	2415	870.5
	5	20425	826.5	2425	871.5
	10	20450	829	2450	874
Mid Range	1.4/3/5/10	20525	836.5	2525	881.5
High Range	1.4	20643	848.3	2643	893.3
	3	20635	847.5	2635	892.5
	5	20625	846.5	2625	891.5
	10	20600	844	2600	889

4. Table for Filed Antenna:

Manufacturer	P/N	Antenna Type	Connector	Gain (dBi)	Note
Shenzhen Bogesi Communication Technology Co., Ltd	XGD-215	FPC	weld	-1.09	GSM 850
				-1.62	WCDMA Band V
				-1.62	LTE Band 5

Note: The antenna gain is provided by the manufacturer.

3.2 DESCRIPTION OF TEST MODES

Following mode(s) is (were) found to be the worst case(s) and selected for the final test.

GSM MODE			
Test Item	Available Channel	Tested Channel	Mode
Output Power & ERP	128 to 251	128, 190, 251	GPRS, EDGE
Occupied Bandwidth	128 to 251	128, 190, 251	EDGE
Conducted Spurious Emissions	128 to 251	190	EDGE
Radiated Spurious Emissions	128 to 251	190	EDGE
Band Edge	128 to 251	128, 251	EDGE
Peak to Average Ratio	128 to 251	128, 190, 251	EDGE
Frequency Stability	128 to 251	190	EDGE

WCDMA BAND V MODE			
Test Item	Available Channel	Tested Channel	Mode
Output Power & ERP	4132 to 4233	4132, 4182, 4233	WCDMA, HSDPA, HSUPA
Occupied Bandwidth	4132 to 4233	4132, 4182, 4233	WCDMA
Conducted Spurious Emissions	4132 to 4233	4182	WCDMA
Radiated Spurious Emissions	4132 to 4233	4182	WCDMA
Band Edge	4132 to 4233	4132, 4233	WCDMA
Peak To Average Ratio	4132 to 4233	4132, 4182, 4233	WCDMA
Frequency Stability	4132 to 4233	4182	WCDMA

LTE BAND 5 MODE					
Test Item	Available Channel	Tested Channel	Channel Bandwidth	Modulation	Mode
Output Power & ERP	20407 to 20643	20407, 20525, 20643	1.4MHz	QPSK, 16QAM, 64QAM	1RB/3RB/6RB
	20415 to 20635	20415, 20525, 20635	3MHz	QPSK, 16QAM, 64QAM	1RB/8RB/15RB
	20425 to 20625	20425, 20525, 20625	5MHz	QPSK, 16QAM, 64QAM	1RB/12RB/25RB
	20450 to 20600	20450, 20525, 20600	10MHz	QPSK, 16QAM, 64QAM	1RB/25RB/50RB
Occupied Bandwidth	20407 to 20643	20407, 20525, 20643	1.4MHz	QPSK, 16QAM, 64QAM	6RB
	20415 to 20635	20415, 20525, 20635	3MHz	QPSK, 16QAM, 64QAM	15RB
	20425 to 20625	20425, 20525, 20625	5MHz	QPSK, 16QAM, 64QAM	25RB
	20450 to 20600	20450, 20525, 20600	10MHz	QPSK, 16QAM, 64QAM	50RB
Conducted Spurious Emissions	20407 to 20643	20525	1.4MHz	QPSK	1RB
	20425 to 20625	20525	5MHz	QPSK	1RB
	20450 to 20600	20525	10MHz	QPSK	1RB
Radiated Spurious Emissions	20407 to 20643	20525	1.4MHz	QPSK	1RB
	20425 to 20625	20525	5MHz	QPSK	1RB
	20450 to 20600	20525	10MHz	QPSK	1RB
Band Edge	20407 to 20643	20407, 20643	1.4MHz	QPSK	1RB/6RB
	20415 to 20635	20415, 20635	3MHz	QPSK	1RB/15RB
	20425 to 20625	20425, 20625	5MHz	QPSK	1RB/25RB
	20450 to 20600	20450, 20600	10MHz	QPSK	1RB/50RB
Peak To Average Ratio	20407 to 20643	20407, 20525, 20643	1.4MHz	QPSK, 16QAM, 64QAM	1RB
	20415 to 20635	20415, 20525, 20635	3MHz	QPSK, 16QAM, 64QAM	1RB
	20425 to 20625	20425, 20525, 20625	5MHz	QPSK, 16QAM, 64QAM	1RB
	20450 to 20600	20450, 20525, 20600	10MHz	QPSK, 16QAM, 64QAM	1RB
Frequency Stability	20450 to 20600	20525	10MHz	QPSK	50RB

Note:

1. Evaluated two kinds of configurations products, the worst case is Configuration 2 and recorded in this report.
2. For radiated spurious emissions test: All adapters had been pre-tested, found the worst case was tested with adapter: ADS-6MA-06 05050EPG and recorded in this report.

3.3 BLOCK DIGRAM SHOWING THE CONFIGURATION OF SYSTEM TESTED

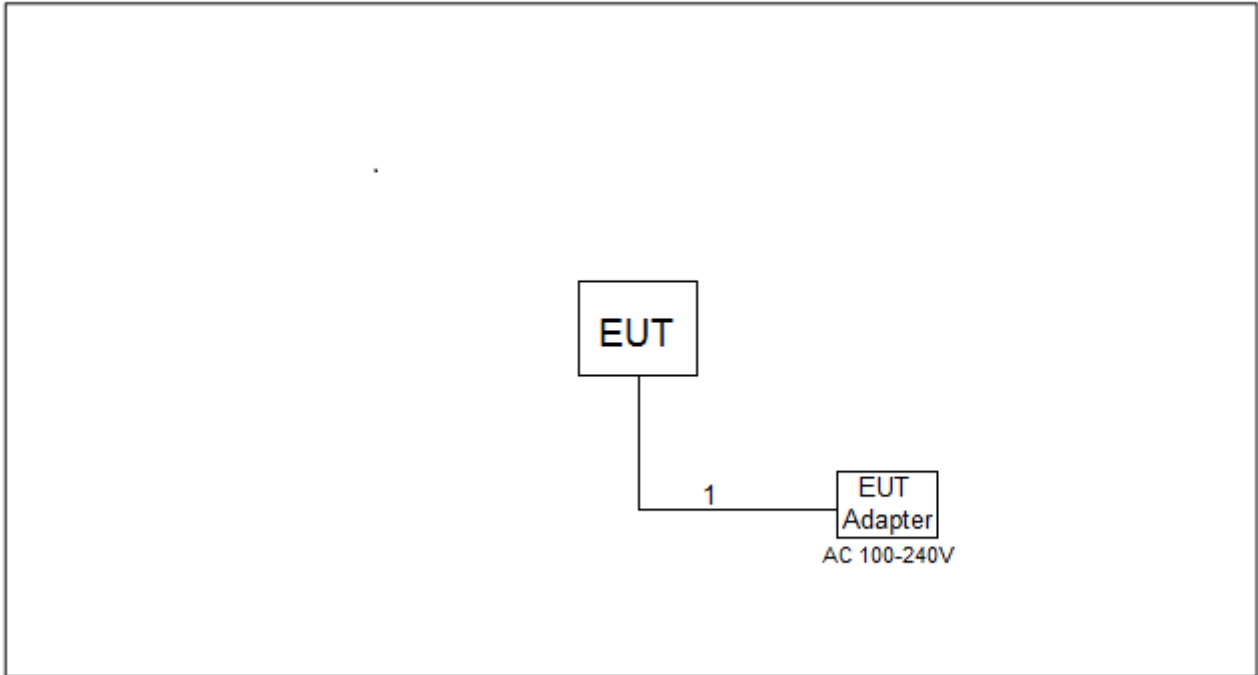

2.4 DESCRIPTION OF SUPPORT UNITS

The EUT has been tested as an independent unit together with other necessary accessories or support units. The following support units or accessories were used to form a representative test configuration during the tests.

Item	Equipment	Mfr/Brand	Model/Type No.	Series No.
-	-	-	-	-

Item	Cable Type	Shielded Type	Ferrite Core	Length
1	DC Cable	NO	NO	1.2m

4. TEST RESULT

4.1 OUTPUT POWER MEASUREMENT

4.1.1 LIMIT

Mobile / Portable station are limited to 7 watts e.r.p.

4.1.2 TEST PROCEDURE

The testing follows FCC KDB 971168 v03r01 Section 5 or ANSI C63.26-2015 Section 5.2.

EIRP / ERP:

$EIRP = \text{Output Power} + \text{Antenan gain}$

$ERP = EIPR - 2.15\text{dBi}$

Output Power:

The EUT was set up for the maximum power with GSM, GPRS, EDGE, WCDMA and LTE link data modulation and link up with simulator. Set the EUT to transmit under low, middle and high channel and record the power level shown on simulator.

4.1.3 TEST SETUP LAYOUT

Output Power Measurement

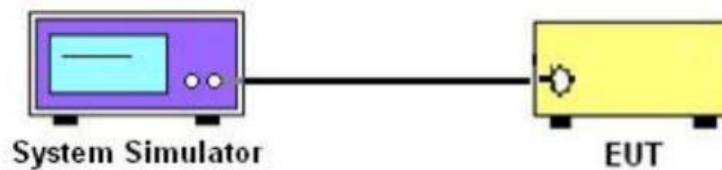

4.1.4 TEST DEVIATION

No deviation

4.1.5 TEST RESULTS

Please refer to the APPENDIX A.

4.2 OCCUPIED BANDWIDTH MEASUREMENT

4.2.1 TEST PROCEDURE

The testing follows FCC KDB 971168 v03r01 Section 4 or ANSI C63.26-2015 Section 5.4.

1. The EUT makes a call to the communication simulator. All measurements were done at low, middle and high operational frequency range. The communication simulator station system controlled a EUT to export maximum output power under transmission mode and specific channel frequency. Use OBW measurement function of Spectrum analyzer to measure 99 % occupied bandwidth and 26dB bandwidth.
2. The EUT was connected to spectrum analyzer and system simulator via a power divider.
3. $RBW=(1\% \sim 5\%)*EBW$
 $VBW \geq 3* RBW$
4. Set spectrum analyzer with Peak detector.

4.2.2 TEST SETUP LAYOUT

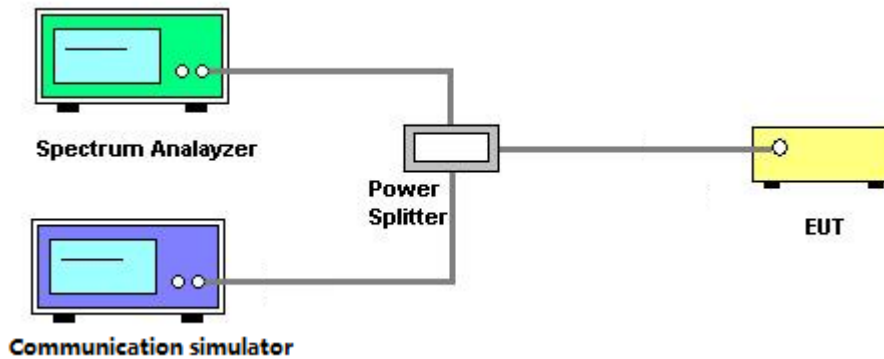

4.2.3 TEST DEVIATION

No deviation

4.2.4 TEST RESULTS

Please refer to the APPENDIX B.

4.3 CONDUCTED SPURIOUS EMISSIONS MEASUREMENT

4.3.1 LIMIT

The power of any emission outside of the authorized operating frequency ranges must be attenuated below the transmitting power (P) by a factor of at least $43 + 10 \log(P)$ dB. The emission limit equal to -13dBm.

4.3.2 TEST PROCEDURES

The testing follows FCC KDB 971168 v03r01 Section 6 or ANSI C63.26-2015 Section 5.7.

1. The EUT was connected to spectrum analyzer and system simulator via a power divider.
2. The band edges of low and high channels for the highest RF powers were measured. Set RBW \geq 1% EBW in the 1MHz band immediately outside and adjacent to the band edge.
3. Set spectrum analyzer with Peak or RMS detector.
4. The RF fundamental frequency should be excluded against the limit line in the operating frequency band.

4.3.3 TEST SETUP LAYOUT

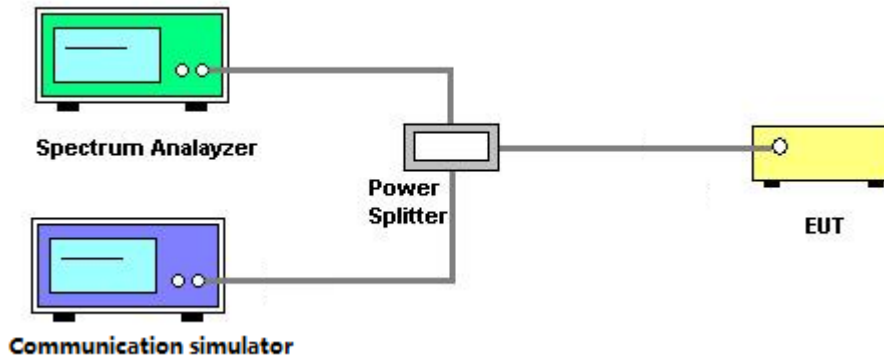

4.3.4 TEST DEVIATION

No deviation

4.3.5 TEST RESULTS

Please refer to the APPENDIX C.

4.4 RADIATED SPURIOUS EMISSIONS MEASUREMENT

4.4.1 LIMIT

The power of any emission outside of the authorized operating frequency ranges must be attenuated below the transmitting power (P) by a factor of at least $43 + 10 \log(P)$ dB. The emission limit equal to -13dBm.

4.4.2 TEST PROCEDURES

The testing follows FCC KDB 971168 v03r01 Section 6.2 or ANSI C63.26-2015 Section 5.5.

1. The EUT was placed on a turntable with 0.8 meter height for frequency below 1GHz and 1.5 meter height for frequency above 1GHz respectively above ground.
2. The EUT was set 3 meters from the receiving antenna mounted on the antenna tower.
3. During the measurement, the system simulator parameters were set to force the EUT transmitting at maximum output power.
4. Start the test, rotate the table 360° to find the worst Angle, maintain the worst Angle, raise the antenna to 1-4m to find the worst height, maintain the worst height, then rotate the table to determine the final worst Angle, grab the spectrum diagram.
5. EUT shall be placed in accordance with X,Y,Z as required by Figure 5 in ANSI C63.26.
Repeat Step 5 above to find the worst placement. Test all bands according to the worst placement.
6. Then EIRP is then converted to field strength as follows in Equation
7. $E \text{ (dBuV/m)} = \text{EIRP (dBm)} - 20\log(D) + 104.8$; where D is the measurement distance (in the far field region) in m. The emission limit equal to 82.26dBuV/m.

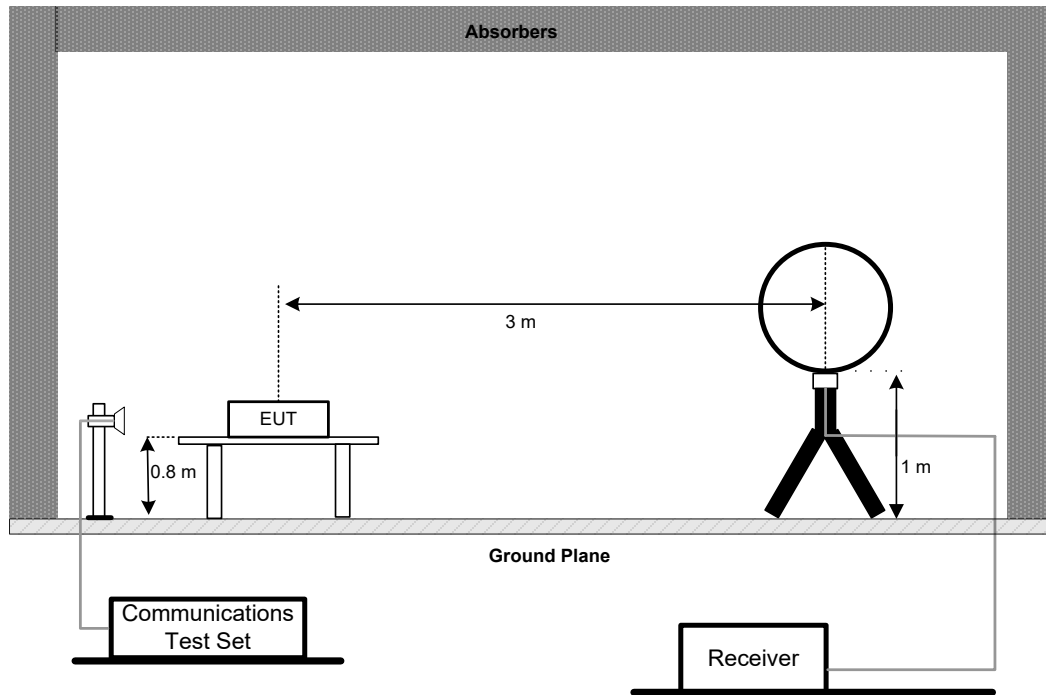
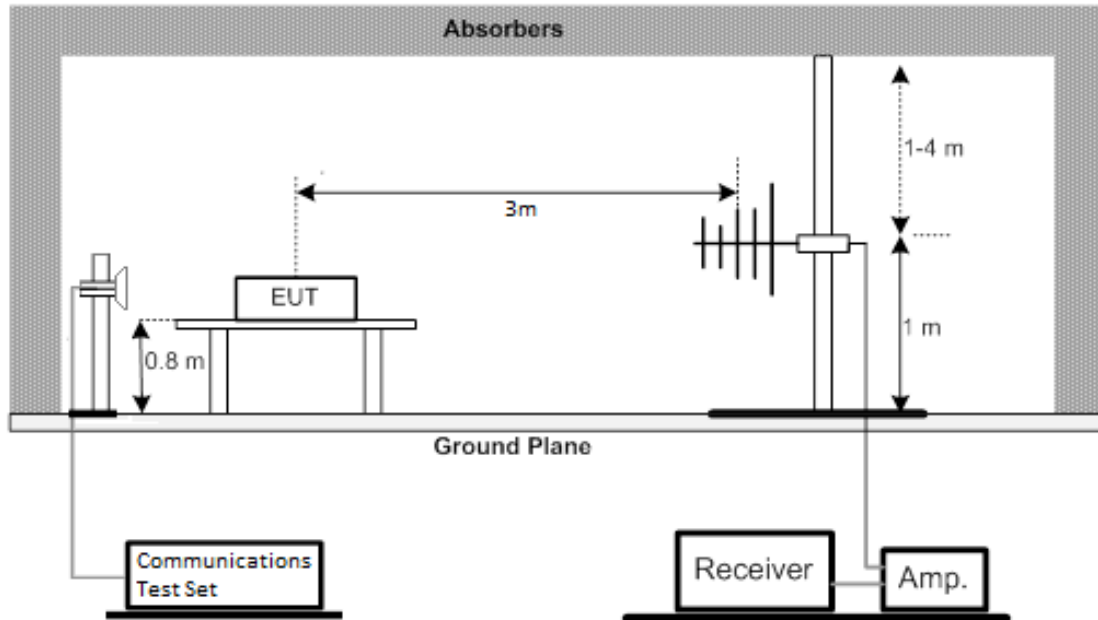
4.4.3 TEST SETUP LAYOUT**Below 30MHz****30MHz to 1000MHz**

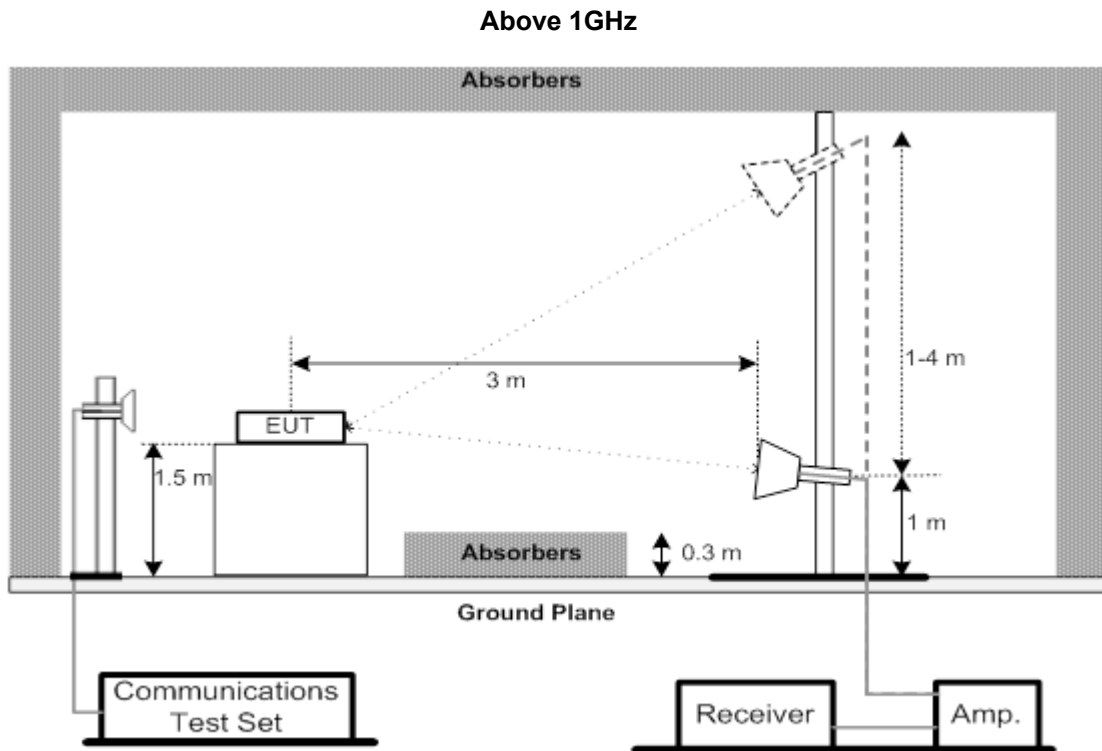

4.4.4 TEST DEVIATION

No deviation

4.4.5 TEST RESULTS (9KHZ TO 30MHZ)

Please refer to the APPENDIX D.

4.4.6 TEST RESULTS (30MHZ TO 1000MHZ)

Please refer to the APPENDIX E.

4.4.7 TEST RESULTS (ABOVE 1000MHZ)

Please refer to the APPENDIX F.

4.5 BAND EDGE MEASUREMENT

4.5.1 LIMIT

A Power of any emission outside of the authorized operating frequency ranges must be attenuated below the transmitting power (P) by a factor of at least $43 + 10 \log(P)$ dB. In the 1 MHz bands immediately outside and adjacent to the frequency block a resolution bandwidth of at least one percent of the emission bandwidth of the fundamental emission of the transmitter may be employed.

4.5.2 TEST PROCEDURES

The testing follows FCC KDB 971168 v03r01 Section 6 or ANSI C63.26-2015 Section 5.7.

1. All measurements were done at low and high operational frequency range.
2. Record the max trace plot into the test report.

4.5.3 TEST SETUP LAYOUT

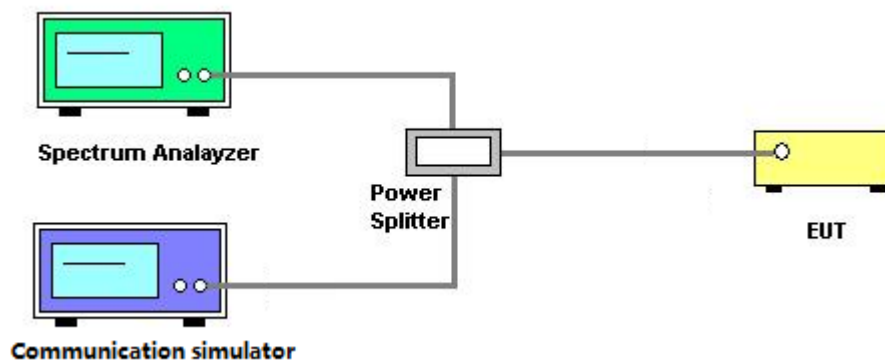

4.5.4 TEST DEVIATION

No deviation

4.5.5 TEST RESULTS

Please refer to the APPENDIX G.

4.6 PEAK TO AVERAGE RATIO MEASUREMENT

4.6.1 LIMIT

In measuring transmissions in this band using an average power technique, the peak to-average ratio (PAR) of the transmission may not exceed 13 dB.

4.6.2 TEST PROCEDURES

The testing follows FCC KDB 971168 v03r01 Section 5.7 or ANSI C63.26-2015 Section 5.2.6.

1. Set resolution/measurement bandwidth \geq signal's occupied bandwidth;
2. Set the number of counts to a value that stabilizes the measured CCDF curve;
3. Record the maximum PAPR level associated with a probability of 0.1%.

4.6.3 TEST SETUP LAYOUT

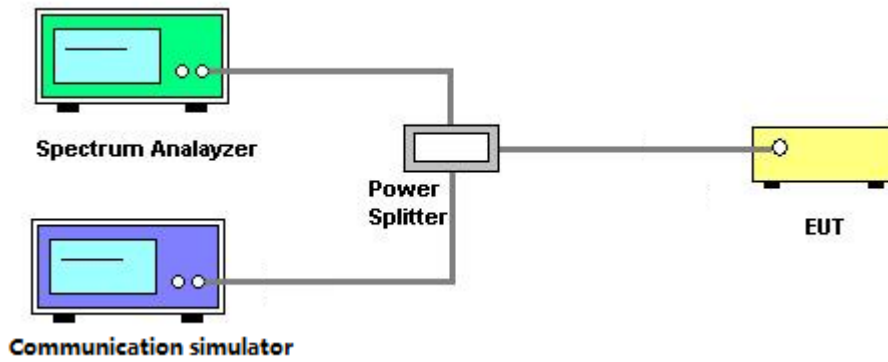

4.6.4 TEST DEVIATION

No deviation

4.6.5 TEST RESULTS

Please refer to the APPENDIX H.

4.7 FREQUENCY STABILITY MEASUREMENT

4.7.1 LIMIT

± 1.5 ppm is for base and fixed station. ± 2.5 ppm is for mobile station.

4.7.2 TEST PROCEDURES

The testing follows FCC KDB 971168 v03r01 Section 9 or ANSI C63.26-2015 Section 5.6.

1. Device is placed at the oven room. The oven room could control the temperatures and humidity. Power warm up is at least 15 min and power applied should perform before recording frequency error.
2. EUT is connected the external power supply to control the DC input power. The test voltage range is from minimum to maximum working voltage. Each step shall be record the frequency error rate.
3. The temperature range step is 10 degrees in this test items. All temperature levels shall be hold the $\pm 0.5^{\circ}\text{C}$ during the measurement testing. The each temperature step shall be at least 0.5 hours, consider the EUT could be test under the stability condition.
4. The frequency error was recorded frequency error from the communication simulator.

4.7.3 TEST SETUP LAYOUT

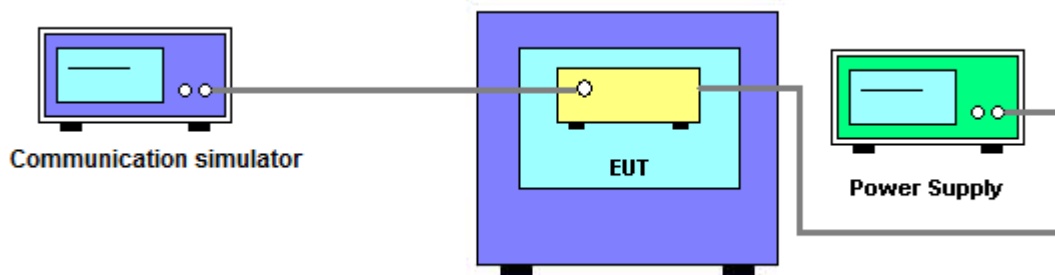

4.7.4 TEST DEVIATION

No deviation

4.7.5 TEST RESULTS

Please refer to the APPENDIX I.

4. LIST OF MEASUREMENT EQUIPMENTS

Radiated Emissions - 9 kHz to 30 MHz					
Item	Kind of Equipment	Manufacturer	Type No.	Serial No.	Calibrated until
1	Active Loop Antenna	Schwarzbeck	FMZB 1513-60	25	Mar. 30, 2025
2	MXE EMI Receiver	Keysight	N9038A	MY56400091	Dec. 22, 2024
3	Cable	N/A	RW2350-3.8A-NMB M-1.5M	N/A	Jun. 10, 2024
4	Measurement Software	Farad	EZ-EMC Ver.NB-03A1-01	N/A	N/A
5	966 Chamber room	ETS	9*6*6	N/A	Jul. 11, 2024

Radiated Emissions - 30 MHz to 1 GHz					
Item	Kind of Equipment	Manufacturer	Type No.	Serial No.	Calibrated until
1	Trilog-Broadband Antenna	Schwarzbeck	VULB9168	01269	May 15, 2024
2	Attenuator	EMC INSTRUMENT	EMCI-N-6-06	AN-N0697	May 15, 2024
3	Preamplifier	EMC INSTRUMENT	EMC001330	980825	Jan. 19, 2025
4	Cable	EMC INSTRUMENT	EMCCFD400-NM-N M-2500	N/A	Jun. 08, 2024
5	Cable	EMC INSTRUMENT	EMCCFD400-NM-N M-7000	N/A	Jun. 08, 2024
6	Cable	EMC INSTRUMENT	EMCCFD400-NM-N M-3000	N/A	Jun. 08, 2024
7	MXE EMI Receiver	KEYSIGHT	N9038A	MY59050118	Sep. 26, 2024
8	Positioning Controller	MF	MF-7802BS	N/A	N/A
9	Max-Full Antenna Corp	MF	MFA-560BSN	N/A	N/A
10	Measurement Software	Farad	EZ-EMC Ver.NB-03A1-01	N/A	N/A
11	966 Chamber room	Tai He	9*6*6 (NSA&VSWR)	N/A	Jun. 07, 2024

Radiated Emissions - Above 1 GHz					
Item	Kind of Equipment	Manufacturer	Type No.	Serial No.	Calibrated until
1	Attenuator	Talent Microwave	TA10A2-S-18	N/A	N/A
2	MXE EMI Receiver	Keysight	N9038A	MY59050118	Sep. 26, 2024
3	Measurement Software	Farad	EZ-EMC Ver.NB-03A1-01	N/A	N/A
4	Preamplifier	EMC INSTRUMENT	EMC118A45SE	980739	Jan. 19, 2025
5	Cable	EMC INSTRUMENT	EMC104-SM-SM-1 0000	N/A	Jun. 08, 2024
6	Cable	EMC INSTRUMENT	EMC104-SM-SM-3 000	N/A	Jun. 08, 2024
7	Cable	EMC INSTRUMENT	EMC104-SM-SM-8 00	N/A	Jun. 08, 2024
8	Double Ridged Broadband Horn Antenna	RF SPIN	DRH18-E	210106A18E	Jul. 04, 2024
9	Preamplifier	EMC INSTRUMENT	EMC184045SE	980793	Jan. 19, 2025
10	Cable	EMC INSTRUMENT	EMC101G-KM-KM- 800	N/A	Aug. 13, 2024
11	Cable	EMC INSTRUMENT	EMC101G-KM-KM- 6000	N/A	Aug. 13, 2024
12	Broad-Band Horn Antenna	Schwarzbeck	BBHA9170	1046	Jul. 05, 2024
13	Band Reject Filter	COM-MW	ZHPF6-C3000-180 00-174	07213126	Jul. 07, 2024
14	Band Reject Filter	COM-MW	ZHPF6-M6500-180 00-547	07213124	Jul. 07, 2024
15	966 Chamber room	Tai He	9*6*6 (NSA&VSWR)	N/A	Jun. 07, 2024

Conducted Measurement					
Item	Kind of Equipment	Manufacturer	Type No.	Serial No.	Calibrated until
1	Wideband Radio Communication Tester	R&S	CWM 500	131463	Jan. 19, 2025
2	Signal Analyzer	R&S	FSV 40	100948	Jul. 07, 2024
3	Temperature Chamber	ESPEC	SU-242	93018777	Jul. 07, 2024
4	MXA Signal Analyzer	Agilent Technologies	N9020A	MY49100060	Jul. 07, 2024

Remark: "N/A" denotes no model name, serial no. or calibration specified.
All calibration period of equipment list is one year.

APPENDIX A - OUTPUT POWER

Output Power (dBm)

GSM850		128CH	190CH	251CH
		824.2MHz	836.6MHz	848.8MHz
GPRS/EDGE (GMSK)	1 Tx Slot	33.49	33.25	33.34
	2 Tx Slot	33.47	33.24	33.34
	3 Tx Slot	32.03	31.72	31.75
	4 Tx Slot	30.13	29.80	29.84
EDGE (8PSK)	1 Tx Slot	28.14	28.48	28.50
	2 Tx Slot	28.02	27.75	28.45
	3 Tx Slot	26.56	26.24	26.24
	4 Tx Slot	23.85	23.72	24.47

Modulation	Band	WCDMA Band V		
	Tx Channel	4132CH	4182CH	4233CH
	Frequency	826.4MHz	836.4MHz	846.6MHz
QPSK	RMC 12.2K	23.17	23.58	23.25
	RMC 64K	23.16	23.55	23.23
	RMC 144K	23.16	23.58	23.26
	RMC 384K	23.19	23.60	23.27
	HSDPA Subtest-1	23.13	23.37	22.95
	HSDPA Subtest-2	22.49	22.77	22.43
	HSDPA Subtest-3	21.97	22.29	21.88
	HSDPA Subtest-4	21.93	22.27	21.87
	HSUPA Subtest-1	21.81	22.24	21.87
	HSUPA Subtest-2	20.77	21.10	20.81
	HSUPA Subtest-3	20.98	21.40	21.04
	HSUPA Subtest-4	20.46	20.84	20.54
	HSUPA Subtest-5	23.02	23.41	23.08

LTE Band / BW	Modulation	RB Size	RB Offset	Low CH	Mid CH	High CH
				20407CH	20525CH	20643CH
				824.7MHz	836.5MHz	848.3MHz
5 / 1.4MHz	QPSK	1	0	23.81	23.53	23.27
		1	2	23.60	23.45	23.13
		1	5	23.69	23.57	23.19
		3	0	23.58	23.48	23.15
		3	1	23.53	23.49	23.12
		3	2	23.55	23.46	23.07
		6	0	22.55	22.48	22.09
	16QAM	1	0	22.86	23.03	22.37
		1	2	22.71	22.90	22.21
		1	5	22.82	22.98	22.26
		3	0	22.61	22.73	22.33
		3	1	22.61	22.73	22.36
		3	2	22.59	22.71	22.35
		6	0	21.77	21.54	21.38
	64QAM	1	0	22.78	22.81	22.32
		1	2	22.62	22.66	22.19
		1	5	22.68	22.76	22.28
		3	0	22.78	22.51	22.27
		3	1	22.78	22.51	22.25
		3	2	22.76	22.50	22.24
		3	2	22.76	22.50	22.24
		6	0	21.66	21.69	21.17

LTE Band / BW	Modulation	RB Size	RB Offset	Low CH	Mid CH	High CH
				20415CH	20525CH	20635CH
				825.5MHz	836.5MHz	847.5MHz
5 / 3MHz	QPSK	1	0	23.51	23.53	23.23
		1	7	23.52	23.55	23.20
		1	14	23.51	23.48	23.11
		8	0	22.54	22.55	22.20
		8	4	22.57	22.55	22.18
		8	7	22.53	22.48	22.12
		15	0	22.56	22.51	22.18
	16QAM	1	0	22.46	22.84	22.26
		1	7	22.48	22.86	22.31
		1	14	22.44	22.82	22.14
		8	0	21.68	21.72	21.27
		8	4	21.70	21.72	21.29
		8	7	21.71	21.65	21.28
		15	0	21.63	21.64	21.18
	64QAM	1	0	23.10	22.65	22.25
		1	7	23.11	22.66	22.30
		1	14	23.07	22.63	22.13
		8	0	21.71	21.66	21.29
		8	4	21.78	21.66	21.32
		8	7	21.79	21.60	21.31
		15	0	21.60	21.66	21.24

LTE Band / BW	Modulation	RB Size	RB Offset	Low CH	Mid CH	High CH	
				20425CH	20525CH	20625CH	
				826.5MHz	836.5MHz	846.5MHz	
5 / 5MHz	QPSK	1	0	23.63	23.37	23.29	
		1	13	23.69	23.53	23.26	
		1	24	23.69	23.41	23.16	
		12	0	22.55	22.46	22.22	
		12	6	22.58	22.55	22.22	
		12	11	22.56	22.47	22.18	
	16QAM	25	0	22.55	22.49	22.15	
		1	0	22.71	22.83	22.35	
		1	13	22.81	23.01	22.37	
		1	24	22.77	22.92	22.23	
		12	0	21.63	21.77	21.36	
		12	6	21.71	21.80	21.38	
	64QAM	12	11	21.69	21.71	21.29	
		25	0	21.63	21.66	21.21	
		1	0	22.49	22.65	22.32	
		1	13	22.59	22.84	22.34	
		1	24	22.55	22.74	22.18	
		12	0	21.57	21.69	21.30	
			12	6	21.65	21.71	21.32
			12	11	21.63	21.63	21.23
			25	0	21.64	21.59	21.31

LTE Band / BW	Modulation	RB Size	RB Offset	Low CH	Mid CH	High CH
				20450CH	20525CH	20600CH
				829.0MHz	836.5MHz	844.0MHz
5 / 10MHz	QPSK	1	0	23.37	23.46	23.23
		1	25	23.53	23.42	23.17
		1	49	23.25	23.24	22.87
		25	0	22.43	22.24	22.12
		25	13	22.53	22.43	22.15
		25	25	22.41	22.22	22.00
		50	0	22.39	22.29	22.05
	16QAM	1	0	22.32	22.76	22.23
		1	25	22.52	22.77	22.18
		1	49	22.22	22.56	21.90
		25	0	21.46	21.45	21.31
		25	13	21.64	21.50	21.31
		25	25	21.53	21.35	21.12
		50	0	21.47	21.35	21.16
	64QAM	1	0	22.96	22.56	22.24
		1	25	23.15	22.58	22.19
		1	49	22.85	22.36	21.90
		25	0	21.48	21.50	21.29
		25	13	21.68	21.55	21.29
		25	25	21.56	21.39	21.10
		50	0	21.52	21.36	21.17

GSM850		ERP (dBm)		
		128CH	190CH	251CH
		824.2MHz	836.6MHz	848.8MHz
GPRS/EDGE (GMSK)	1 Tx Slot	30.25	30.01	30.10
	2 Tx Slot	30.23	30.00	30.10
	3 Tx Slot	28.79	28.48	28.51
	4 Tx Slot	26.89	26.56	26.60
EDGE (8PSK)	1 Tx Slot	24.90	25.24	25.26
	2 Tx Slot	24.78	24.51	25.21
	3 Tx Slot	23.32	23.00	23.00
	4 Tx Slot	20.61	20.48	21.23

Modulation	Band	WCDMA Band V		
	Tx Channel	4132CH	4182CH	4233CH
	Frequency	826.4MHz	836.4MHz	846.6MHz
QPSK	RMC 12.2K	19.40	19.81	19.48
	RMC 64K	19.39	19.78	19.46
	RMC 144K	19.39	19.81	19.49
	RMC 384K	19.42	19.83	19.50
	HSDPA Subtest-1	19.36	19.60	19.18
	HSDPA Subtest-2	18.72	19.00	18.66
	HSDPA Subtest-3	18.20	18.52	18.11
	HSDPA Subtest-4	18.16	18.50	18.10
	HSUPA Subtest-1	18.04	18.47	18.10
	HSUPA Subtest-2	17.00	17.33	17.04
	HSUPA Subtest-3	17.21	17.63	17.27
	HSUPA Subtest-4	16.69	17.07	16.77
	HSUPA Subtest-5	19.25	19.64	19.31

LTE Band / BW	Modulation	RB Size	RB Offset	Low CH	Mid CH	High CH
				20407CH	20525CH	20643CH
				824.7MHz	836.5MHz	848.3MHz
5 / 1.4MHz	QPSK	1	0	20.04	19.76	19.50
		1	2	19.83	19.68	19.36
		1	5	19.92	19.80	19.42
		3	0	19.81	19.71	19.38
		3	1	19.76	19.72	19.35
		3	2	19.78	19.69	19.30
		6	0	18.78	18.71	18.32
	16QAM	1	0	19.09	19.26	18.60
		1	2	18.94	19.13	18.44
		1	5	19.05	19.21	18.49
		3	0	18.84	18.96	18.56
		3	1	18.84	18.96	18.59
		3	2	18.82	18.94	18.58
		6	0	18.00	17.77	17.61
	64QAM	1	0	19.01	19.04	18.55
		1	2	18.85	18.89	18.42
		1	5	18.91	18.99	18.51
		3	0	19.01	18.74	18.50
		3	1	19.01	18.74	18.48
		3	2	18.99	18.73	18.47
		6	0	17.89	17.92	17.40

LTE Band / BW	Modulation	RB Size	RB Offset	Low CH	Mid CH	High CH
				20415CH	20525CH	20635CH
				825.5MHz	836.5MHz	847.5MHz
5 / 3MHz	QPSK	1	0	19.74	19.76	19.46
		1	7	19.75	19.78	19.43
		1	14	19.74	19.71	19.34
		8	0	18.77	18.78	18.43
		8	4	18.80	18.78	18.41
		8	7	18.76	18.71	18.35
		15	0	18.79	18.74	18.41
	16QAM	1	0	18.69	19.07	18.49
		1	7	18.71	19.09	18.54
		1	14	18.67	19.05	18.37
		8	0	17.91	17.95	17.50
		8	4	17.93	17.95	17.52
		8	7	17.94	17.88	17.51
		15	0	17.86	17.87	17.41
	64QAM	1	0	19.33	18.88	18.48
		1	7	19.34	18.89	18.53
		1	14	19.30	18.86	18.36
		8	0	17.94	17.89	17.52
		8	4	18.01	17.89	17.55
		8	7	18.02	17.83	17.54
		15	0	17.83	17.89	17.47

LTE Band / BW	Modulation	RB Size	RB Offset	Low CH	Mid CH	High CH
				20425CH	20525CH	20625CH
				826.5MHz	836.5MHz	846.5MHz
5 / 5MHz	QPSK	1	0	19.86	19.60	19.52
		1	13	19.92	19.76	19.49
		1	24	19.92	19.64	19.39
		12	0	18.78	18.69	18.45
		12	6	18.81	18.78	18.45
		12	11	18.79	18.70	18.41
		25	0	18.78	18.72	18.38
	16QAM	1	0	18.94	19.06	18.58
		1	13	19.04	19.24	18.60
		1	24	19.00	19.15	18.46
		12	0	17.86	18.00	17.59
		12	6	17.94	18.03	17.61
		12	11	17.92	17.94	17.52
		25	0	17.86	17.89	17.44
	64QAM	1	0	18.72	18.88	18.55
		1	13	18.82	19.07	18.57
		1	24	18.78	18.97	18.41
		12	0	17.80	17.92	17.53
		12	6	17.88	17.94	17.55
		12	11	17.86	17.86	17.46
		25	0	17.87	17.82	17.54

LTE Band / BW	Modulation	RB Size	RB Offset	Low CH	Mid CH	High CH
				20450CH	20525CH	20600CH
				829.0MHz	836.5MHz	844.0MHz
5 / 10MHz	QPSK	1	0	19.60	19.69	19.46
		1	25	19.76	19.65	19.40
		1	49	19.48	19.47	19.10
		25	0	18.66	18.47	18.35
		25	13	18.76	18.66	18.38
		25	25	18.64	18.45	18.23
		50	0	18.62	18.52	18.28
	16QAM	1	0	18.55	18.99	18.46
		1	25	18.75	19.00	18.41
		1	49	18.45	18.79	18.13
		25	0	17.69	17.68	17.54
		25	13	17.87	17.73	17.54
		25	25	17.76	17.58	17.35
		50	0	17.70	17.58	17.39
	64QAM	1	0	19.19	18.79	18.47
		1	25	19.38	18.81	18.42
		1	49	19.08	18.59	18.13
		25	0	17.71	17.73	17.52
		25	13	17.91	17.78	17.52
		25	25	17.79	17.62	17.33
		50	0	17.75	17.59	17.40

APPENDIX B - OCCUPIED BANDWIDTH

GSM850_EDGE			
Channel	Frequency (MHz)	99% Occupied Bandwidth (MHz)	26dB Bandwidth (MHz)
		QPSK	QPSK
128	824.2	0.3382	0.4450
190	836.6	0.3146	0.4195
251	848.8	0.3196	0.4660

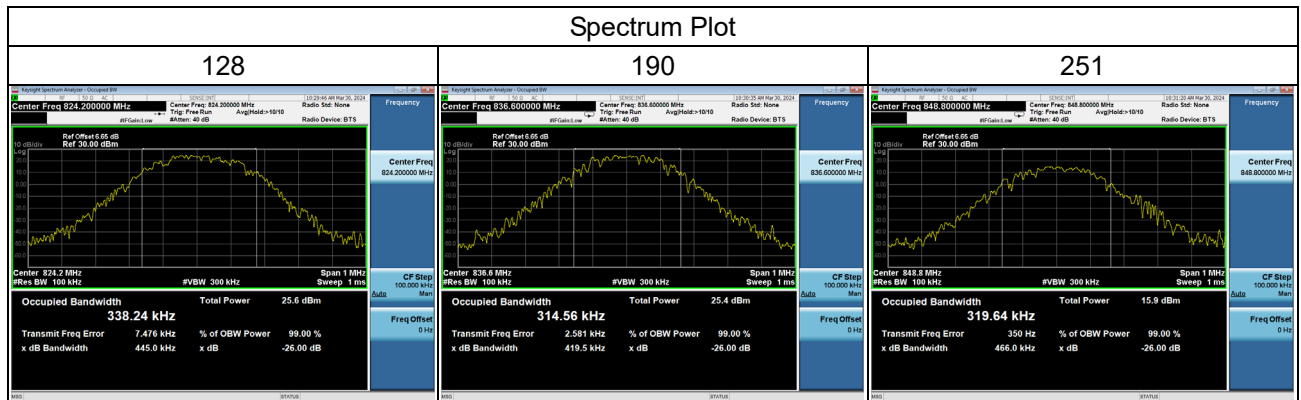

WCDMA Band V_WCDMA			
Channel	Frequency (MHz)	99% Occupied Bandwidth (MHz)	26dB Bandwidth (MHz)
		QPSK	QPSK
4132	826.4	4.1604	4.7200
4182	836.4	4.1520	4.7080
4233	846.6	4.1613	4.7340

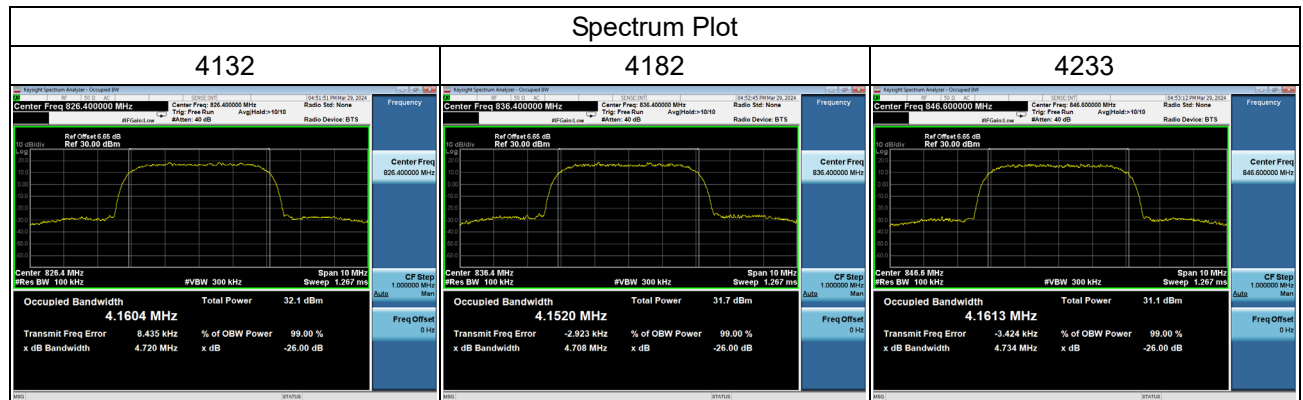

LTE Band 5_1.4MHz							
Channel	Frequency (MHz)	99% Occupied Bandwidth (MHz)			26dB Bandwidth (MHz)		
		QPSK	16QAM	64QAM	QPSK	16QAM	64QAM
20407	824.7	1.1034	1.0966	1.0972	1.2620	1.2550	1.2580
20525	836.5	1.0908	1.0912	1.0889	1.2540	1.2580	1.2570
20643	848.3	1.0939	1.0978	1.0987	1.2540	1.2640	1.2490

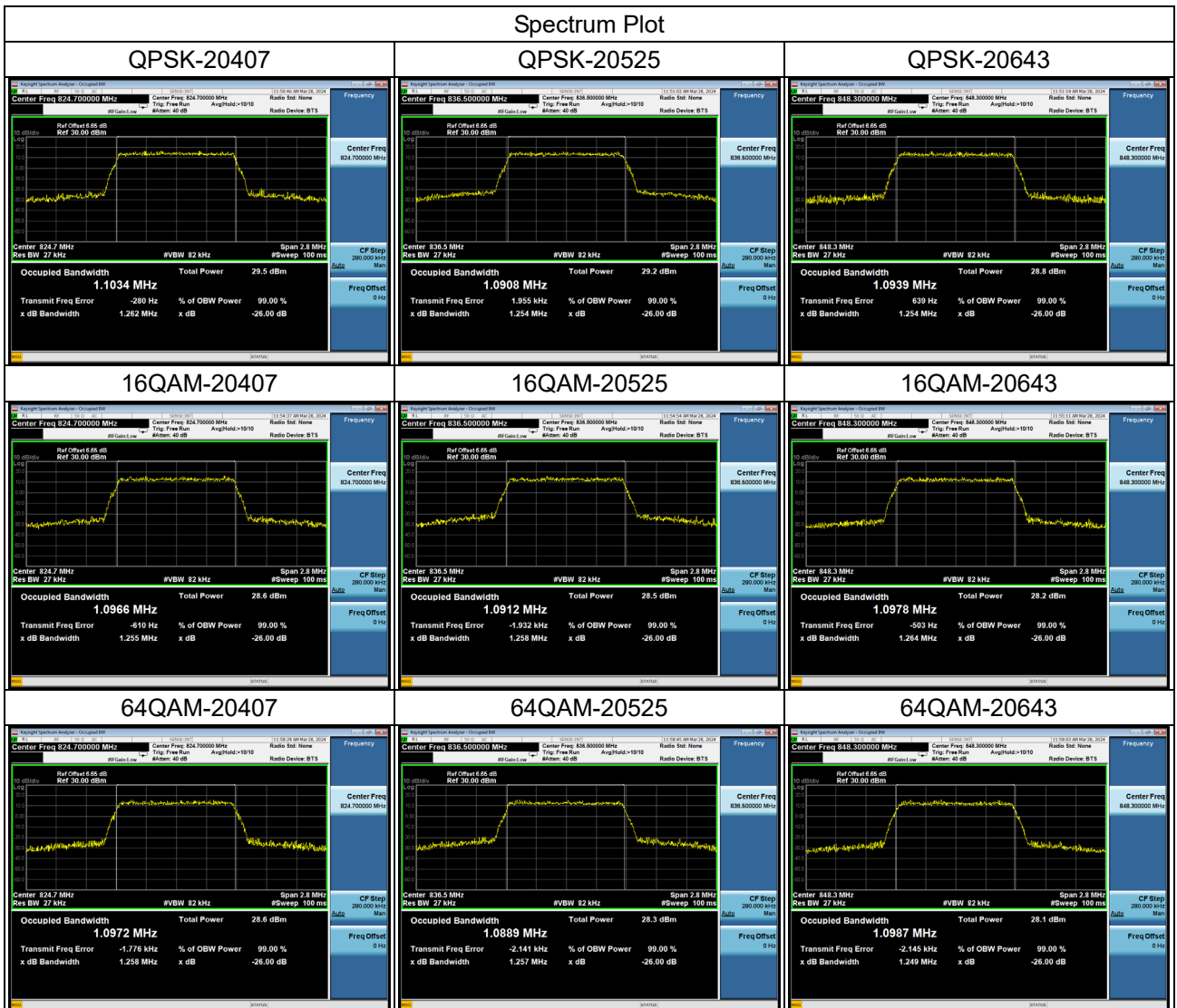

LTE Band 5_3MHz							
Channel	Frequency (MHz)	99% Occupied Bandwidth (MHz)			26dB Bandwidth (MHz)		
		QPSK	16QAM	64QAM	QPSK	16QAM	64QAM
20415	825.5	2.6922	2.6992	2.6984	2.9160	2.9280	2.9100
20525	836.5	2.6976	2.7010	2.6930	2.9190	2.9270	2.9160
20635	847.5	2.6996	2.6906	2.6908	2.9000	2.9240	2.9170

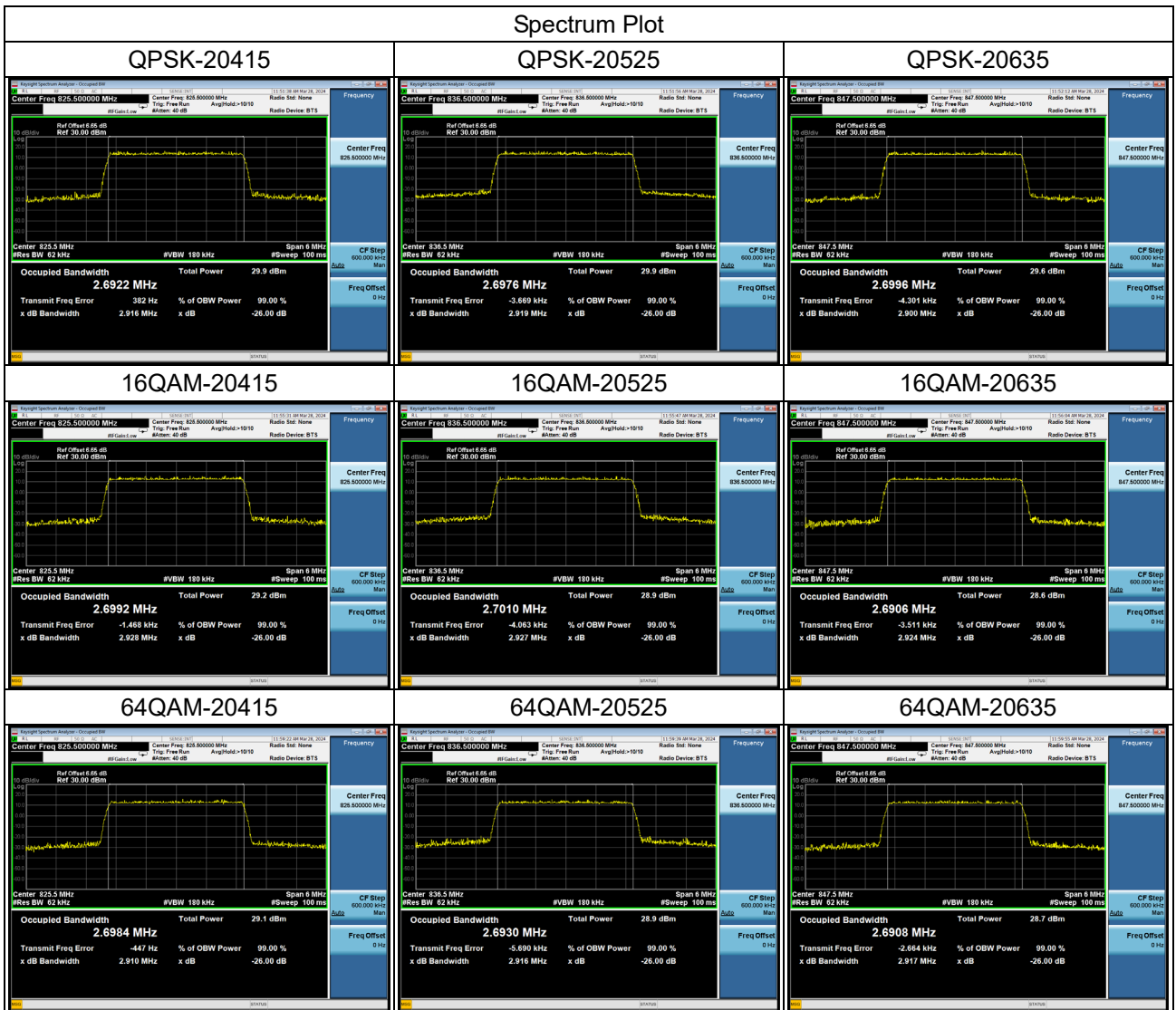

LTE Band 5_5MHz							
Channel	Frequency (MHz)	99% Occupied Bandwidth (MHz)			26dB Bandwidth (MHz)		
		QPSK	16QAM	64QAM	QPSK	16QAM	64QAM
20425	826.5	4.5002	4.4899	4.4942	4.8540	4.8700	4.8260
20525	836.5	4.4956	4.4870	4.4994	4.8420	4.8660	4.8250
20625	846.5	4.5032	4.4899	4.4830	4.8380	4.8220	4.8300



LTE Band 5_10MHz							
Channel	Frequency (MHz)	99% Occupied Bandwidth (MHz)			26dB Bandwidth (MHz)		
		QPSK	16QAM	64QAM	QPSK	16QAM	64QAM
20450	829.0	8.9487	8.9334	8.9678	9.6790	9.6480	9.6030
20525	836.5	8.9545	8.9478	8.9540	9.6370	9.6210	9.6080
20600	844.0	8.9721	8.9624	8.9676	9.6290	9.6330	9.6410

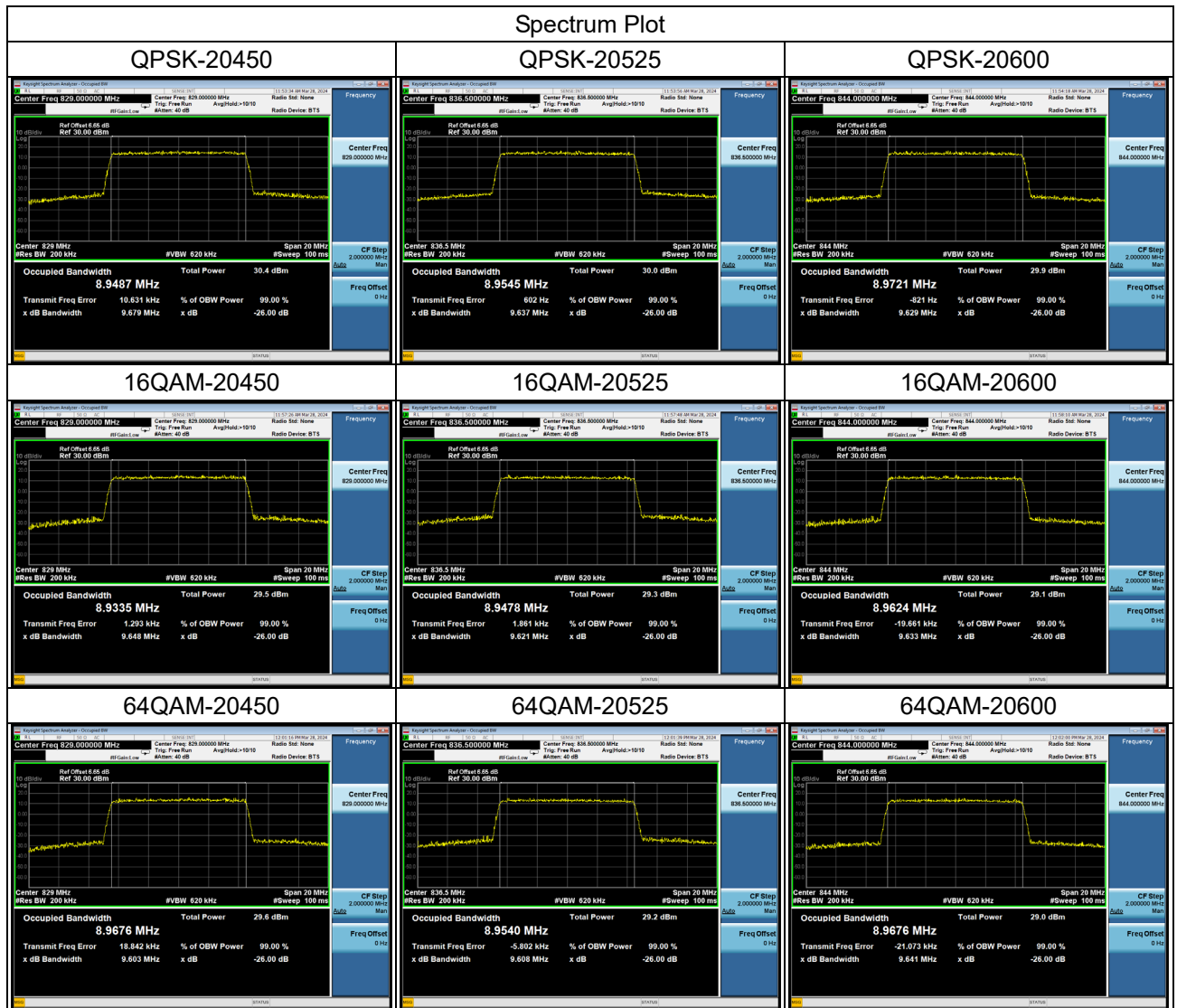

APPENDIX C - CONDUCTED SPURIOUS EMISSIONS